



# THE DATASHEET OF SN65LVCP418PAPT



## 8-Channel Gigabit Signal Conditioning Buffer

Check for Samples: [SN65LVCP418](#)

### FEATURES

- 8 Input and 8 Output Signal Conditioning Buffer
- Up to 4.25 Gbps Operation
- 30 ps of Deterministic Jitter
- Selectable Transmit Pre-Emphasis Per Lane
- Selectable Receive Equalization
- Available Packaging 64 Pin QFP
- Propagation Delay Times: 400 ps Typical
- Inputs Electrically Compatible With CML Signal Levels
- Operates From a Single 3.3-V Supply
- Ability to 3-State Outputs
- Integrated Termination Resistors
- I<sup>2</sup>C™ Control Interface

### APPLICATIONS

- Clock Buffering/Clock MUXing
- Wireless Base Stations
- High-Speed Network Routing
- Telecom/Datacom
- XAUI 802.3ae Protocol Backplane Repeaters

### DESCRIPTION

The SN65LVCP418 is an 8 Channel signal conditioning buffer in a flow-through pin-out allowing for ease in PCB layout. VML signaling is used to achieve a high-speed data throughput while using low power. Internal signal paths are fully differential to achieve the high signaling speeds while maintaining low signal skews. The SN65LVCP418 incorporates 100-Ω termination resistors for those applications where board space is a premium. Built-in transmit pre-emphasis and receive equalization for superior signal integrity performance.

The SN65LVCP418 is characterized for operation from –40°C to 85°C.

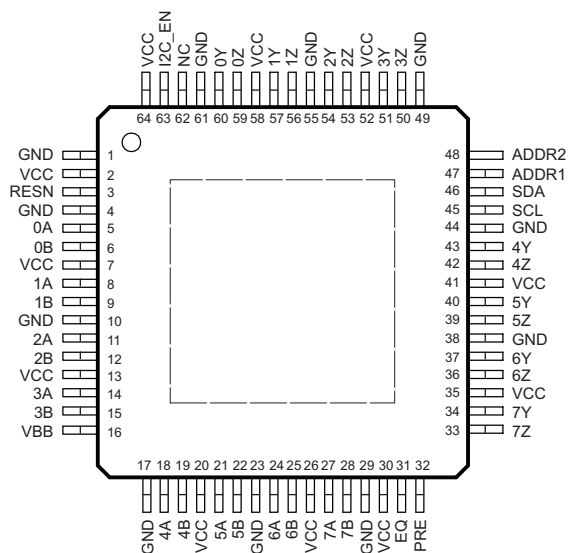

Please be aware that an important notice concerning availability, standard warranty, and use in critical applications of Texas Instruments semiconductor products and disclaimers thereto appears at the end of this data sheet.

PowerPAD is a trademark of Texas Instruments.

I<sup>2</sup>C is a trademark of Philips Electronics.



These devices have limited built-in ESD protection. The leads should be shorted together or the device placed in conductive foam during storage or handling to prevent electrostatic damage to the MOS gates.

LOGIC DIAGRAM

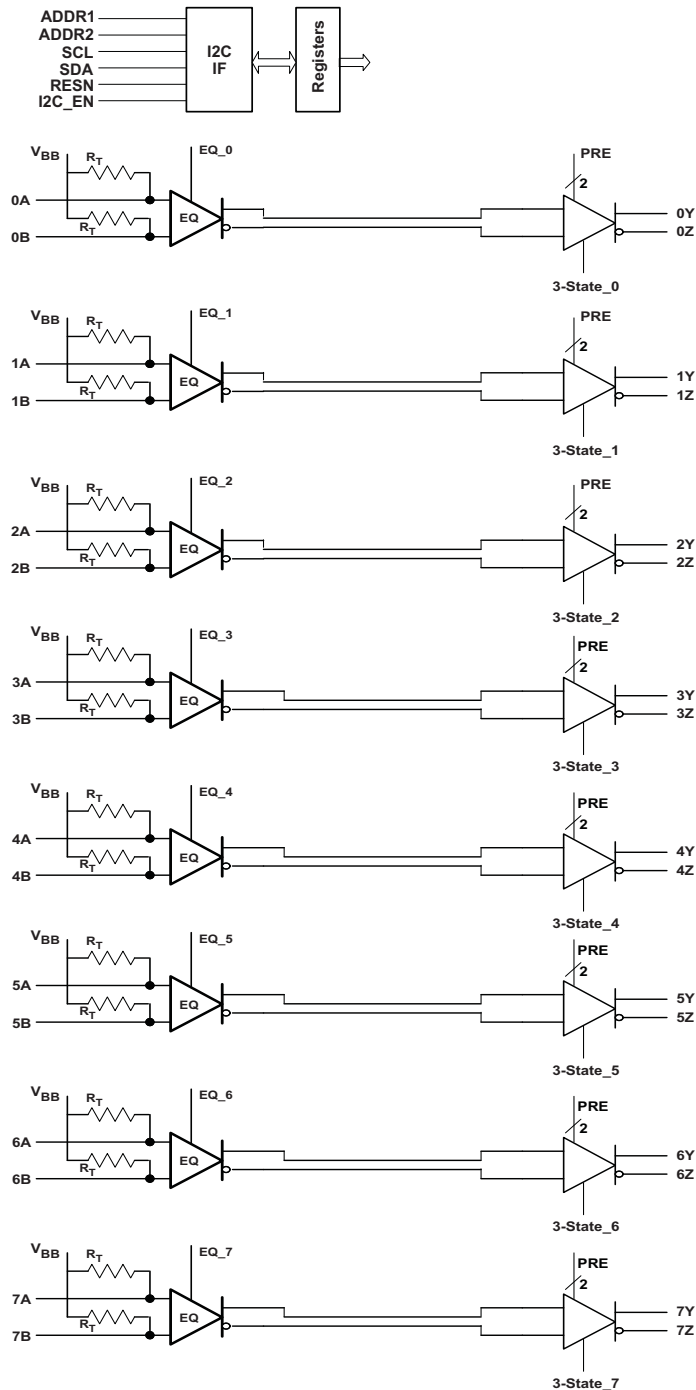

- A. V<sub>BB</sub>: Receiver input internal biasing voltage (allows ac coupling)
- B. R<sub>T</sub>: Internal 50-Ω receiver termination (100-Ω differential)

**PIN FUNCTIONS**

PIN		TYPE	DESCRIPTION
NAME	NO.		
<b>HIGH SPEED I/O</b>			
xA	5, 8, 11, 14, 18, 21, 24, 27	Differential Inputs (with 50-Ω termination to V <sub>bb</sub> ) xA=P; xB=N	Line Side Differential Inputs CML compatible
xB	6, 9, 12, 15, 19, 22, 25, 28		
xY	34, 37, 40 43, 51, 54, 57, 60	Differential Output xY=P; xZ=N	Switch Side Differential Outputs. VML
xZ	33, 36, 39, 42, 50, 53, 56, 59		
<b>CONTROL SIGNALS</b>			
SCL	45	Inputs	I <sup>2</sup> C Control Interface (SCL: Clock, SDA: Data, ADDR: Address)
SDA	46		
ADDR1	47		
ADDR2	48		
EQ	31	Input	Equalization setting when I <sup>2</sup> C is not enabled. EQ=0 13dB and EQ=1 for 9dB
PRE	32	Input	Pre-Emphasis setting when I <sup>2</sup> C is not enabled. PRE=0 for 0 dB and PRE=1 for 6 dB
I2C_EN	63	Input	Enables I <sup>2</sup> C control interface I <sup>2</sup> C_EN=1 for enable; When EN=0 then the PRE and EQ pins are used to set the Pre-Emphasis and Equalization settings rather than the I <sup>2</sup> C register map.
NC	62	Input	No Connect
RESN	3	Input (Active Low)	Configuration Reset. Resets I <sup>2</sup> C register space; Note upon device startup the RESN pin must be driven low to reset the device registers.
<b>POWER SUPPLY</b>			
VCC	2, 7, 13, 20, 26, 30, 35, 41, 52, 58, 64	Power	Power Supply 3.3v±5%
GND	1, 4, 10, 17, 23, 29, 38, 44, 49, 55, 61	Ground	
PowerPAD™		Ground	The ground center pad of the package must be connected to GND plane.
V <sub>BB</sub>	16	Input	Receiver input biasing voltage

**EQUIVALENT INPUT AND OUTPUT SCHEMATIC DIAGRAMS**

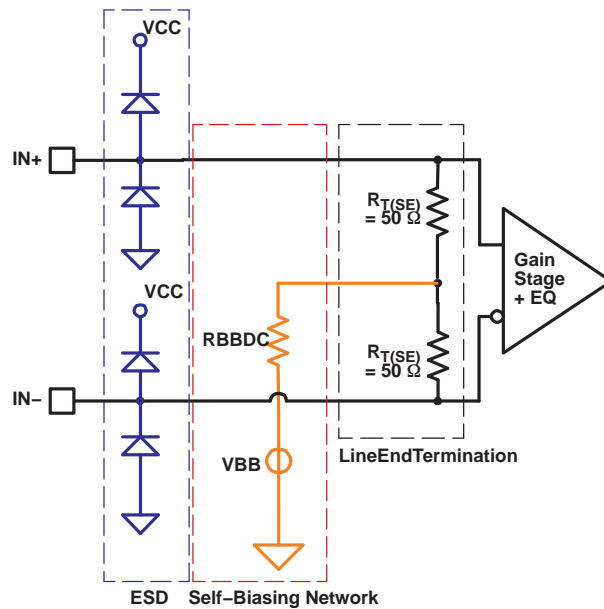

**Figure 1. Equivalent Input Circuit Design**

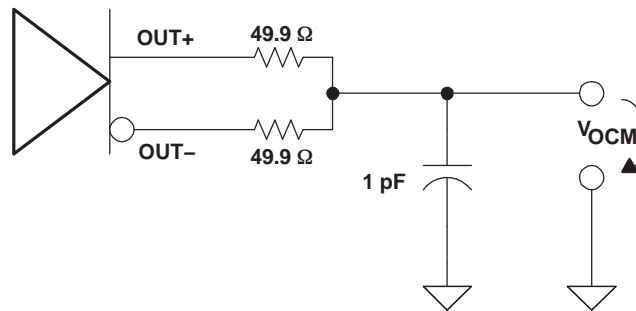

**Figure 2. Common-Mode Output Voltage Test Circuit**

**AVAILABLE OPTIONS**

T <sub>A</sub>	DESCRIPTION	PACKAGED DEVICE <sup>(1)</sup> (2)
		PAP (64 pin)
-40°C to 85°C	Multi Channel Gigabit Signal Conditioner	SN65LVCP418

- (1) The package is available taped and reeled. Add an R suffix to device types (e.g., SN65LVCP418PAP). Temperature range assumes 1 m/s airflow.
- (2) For the most current package and ordering information, see the Package Option Addendum at the end of this document, or see the TI website at [www.ti.com](http://www.ti.com).

**PACKAGE THERMAL CHARACTERISTICS**

PACKAGE THERMAL CHARACTERISTICS <sup>(1)</sup>		NOM	UNIT
θ <sub>JA</sub> (junction-to-ambient)	100LFM airflow is required otherwise a 4x4 thermal via array must be implemented with 6 layer or greater PCB	21.2	°C/W

- (1) See application note [SPRA953](http://www.ti.com/lit/zip/spra953) for a detailed explanation of thermal parameters.

## ABSOLUTE MAXIMUM RATINGS

 over operating free-air temperature range (unless otherwise noted)<sup>(1)</sup>

		UNIT	
V <sub>CC</sub>	Supply voltage range <sup>(2)</sup>	–0.5 V to 6 V	
Voltage range		Control inputs, all outputs	–0.5 V to (V <sub>CC</sub> + 0.5 V)
		Receiver inputs	–0.5 V to 4 V
ESD	Human Body Model <sup>(3)</sup>	All pins	6 kV
	Charged-Device Model <sup>(4)</sup>	All pins	500 V
T <sub>J</sub>	Maximum junction temperature	See Package Thermal Characteristics Table	
Moisture sensitivity level		2	

- (1) Stresses beyond those listed under absolute maximum ratings may cause permanent damage to the device. These are stress ratings only and functional operation of the device at these or any other conditions beyond those indicated under recommended operating conditions is not implied. Exposure to absolute-maximum-rated conditions for extended periods may affect device reliability.
- (2) All voltage values, except differential I/O bus voltages, are with respect to network ground terminal.
- (3) Tested in accordance with JEDEC Standard 22, Test Method A114-A.
- (4) Tested in accordance with JEDEC Standard 22, Test Method C101.

## RECOMMENDED OPERATING CONDITIONS

		MIN	NOM	MAX	UNIT		
dR	Operating data rate			4.25	Gbps		
V <sub>CC</sub>	Supply voltage	3.135	3.3	3.465	V		
V <sub>CC(N)</sub>	Supply voltage noise amplitude	10 Hz to 2.125 GHz		20	mV		
T <sub>J</sub>	Junction temperature			125	°C		
T <sub>A</sub>	Operating free-air temperature <sup>(1)</sup>	Assumes 4×4 thermal via array is implemented with 6 layer or greater PCB otherwise 100LFM airflow is required.		–40	85	°C	
<b>DIFFERENTIAL INPUTS</b>							
V <sub>ID</sub>	Receiver peak-to-peak differential input voltage <sup>(2)</sup>	dR <sub>(in)</sub> ≤ 4.25 Gbps		100	1750	mV <sub>PP</sub>	
		1.25 Gbps < dR <sub>(in)</sub> ≤ 4.25 Gbps		100	1560	mV <sub>PP</sub>	
		dR <sub>(in)</sub> > 4.25 Gbps		100	1000	mV <sub>PP</sub>	
V <sub>ICM</sub>	Receiver common-mode input voltage	Note: for best jitter performance ac coupling is recommended.		1.5	1.6	V <sub>CC</sub> – $\frac{ V_{ID} }{2}$	V
<b>CONTROL INPUTS</b>							
V <sub>IH</sub>	High-level input voltage			2	V <sub>CC</sub> + 0.3	V	
V <sub>IL</sub>	Low-level input voltage			–0.3	0.8	V	
<b>DIFFERENTIAL OUTPUTS</b>							
R <sub>L</sub>	Differential load resistance	80	100	120	Ω		

- (1) Maximum free-air temperature operation is allowed as long as the device maximum junction temperature is not exceeded.
- (2) Differential input voltage V<sub>ID</sub> is defined as |IN+ – IN–|.

## ELECTRICAL CHARACTERISTICS

over operating free-air temperature range (unless otherwise noted)

PARAMETER		TEST CONDITIONS	MIN	TYP <sup>(1)</sup>	MAX	UNIT
<b>DIFFERENTIAL INPUTS</b>						
V <sub>IT+</sub>	Positive going differential input high threshold				50	mV
V <sub>IT-</sub>	Negative going differential input low threshold		-50			mV
A <sub>(EQ)</sub>	Equalizer gain	at 1.875 GHz (EQ=1)		9		dB
R <sub>T(D)</sub>	Termination resistance, differential		80	100	120	Ω
V <sub>BB</sub>	Open-circuit Input voltage (input self-bias voltage)	AC-coupled inputs		1.6		V
R <sub>(BBDC)</sub>	Biasing network dc impedance			30		kΩ
R <sub>(BBAC)</sub>	Biasing network ac impedance	375 MHz		42		Ω
		2.125 GHz		8.4		
<b>DIFFERENTIAL OUTPUTS</b>						
V <sub>ODH</sub>	High-level output voltage	R <sub>L</sub> = 100 Ω ±1%, Figure 3		650		mV <sub>PP</sub>
V <sub>ODL</sub>	Low-level output voltage			-650		mV <sub>PP</sub>
V <sub>ODB</sub>	Output differential voltage without pre-emphasis <sup>(2)</sup>		1000	1300	1500	mV <sub>PP</sub>
V <sub>OCM</sub>	Output common mode voltage			1.8		V
ΔV <sub>OC(SS)</sub>	Change in steady-state common-mode output voltage between logic states	See Figure 2		1		mV
V <sub>(PE)</sub>	Output preemphasis voltage ratio, $\frac{V_{ODB(PP)}}{V_{ODPE(PP)}}$	R <sub>L</sub> = 100 Ω ±1%; x = L or S; See Figure 3		0		dB
				3		
				6		
				10		
t <sub>(PRE)</sub>	Preemphasis duration measurement	Output preemphasis is set to 10 dB during test Measured with a 100-MHz clock signal; R <sub>L</sub> = 100 Ω ±1%, See Figure 4		175		ps
r <sub>o</sub>	Output resistance	Differential on-chip termination between OUT+ and OUT-		100		Ω
<b>CONTROL INPUTS</b>						
I <sub>IH</sub>	High-level Input current	V <sub>IN</sub> = V <sub>CC</sub>			5	μA
I <sub>IL</sub>	Low-level Input current	V <sub>IN</sub> = GND	-125	-90		μA
R <sub>(PU)</sub>	Pullup resistance			35		kΩ
<b>POWER CONSUMPTION</b>						
P <sub>D</sub>	Device power dissipation	All outputs terminated 100 Ω			1.32	W
P <sub>Z</sub>	Device power dissipation in 3-State	All outputs in 3-state			684	mW
I <sub>CC</sub>	Device current consumption	All outputs terminated 100 Ω			380	mA
						PRBS 2 <sup>7-1</sup> pattern at 4.25 Gbps

(1) All typical values are at T<sub>A</sub> = 25°C and V<sub>CC</sub> = 3.3 V supply unless otherwise noted. They are for reference purposes and are not production tested.

(2) Differential output voltage V<sub>(ODB)</sub> is defined as | OUT+ – OUT- |.

## SWITCHING CHARACTERISTICS

over operating free-air temperature range (unless otherwise noted)

PARAMETER		TEST CONDITIONS			MIN	TYP <sup>(1)</sup>	MAX	UNIT
<b>DIFFERENTIAL OUTPUTS</b>								
$t_{PLH}$	Low-to-high propagation delay	Propagation delay input to output, See <a href="#">Figure 6</a>			0.4	0.8		ns
$t_{PHL}$	High-to-low propagation delay				0.4	0.8		ns
$t_r$	Rise time	20% to 80% of $V_{O(DB)}$ ; Test Pattern: 100-MHz clock signal; See <a href="#">Figure 5</a> and <a href="#">Figure 8</a>			90			ps
$t_f$	Fall time				90			ps
$t_{sk(p)}$	Pulse skew, $ t_{PHL} - t_{PLH} $ <sup>(2)</sup>					11		ps
$t_{sk(o)}$	Output skew <sup>(3)</sup>	All outputs terminated with 100 $\Omega$			25	75		ps
$t_{sk(pp)}$	Part-to-part skew <sup>(4)</sup>					150		ps
$t_{zd}$	3-State switch time to Disable	Assumes 50 $\Omega$ to $V_{cm}$ and 150 pF load on each output				30		ns
$t_{ze}$	3-State switch time to Enable	Assumes 50 $\Omega$ to $V_{cm}$ and 150 pF load on each output				20		ns
RJ	Device random jitter, rms	See <a href="#">Figure 8</a> for test circuit. BERT setting $10^{-15}$ Alternating 10-pattern.			0.8	2		ps-rms
DJ	Intrinsic deterministic device jitter <sup>(5)</sup> , peak-to-peak	0 dB preemphasis See <a href="#">Figure 8</a> for the test circuit.	PRBS $2^{7-1}$ pattern	4.25 Gbps		30		ps
	Absolute deterministic output jitter <sup>(6)</sup> , peak-to-peak	0 dB preemphasis See <a href="#">Figure 8</a> for the test circuit.	PRBS $2^{7-1}$ pattern	1.25Gbps; EQ=13 Over 25-inch FR4 trace 4.25 Gbps; EQ=0 Over FR4 trace 2-inch to 43 inches long		12		ps
					20			

(1) All typical values are at 25°C and with 3.3 V supply unless otherwise noted.

(2)  $t_{sk(p)}$  is the magnitude of the time difference between the  $t_{PLH}$  and  $t_{PHL}$  of any output of a single device.

(3)  $t_{sk(o)}$  is the magnitude of the time difference between the  $t_{PLH}$  and  $t_{PHL}$  of any two outputs of a single device.

(4)  $t_{sk(pp)}$  is the magnitude of the difference in propagation delay times between any specified terminals of two devices when both devices operate with the same supply voltages, at the same temperature, and have identical packages and test circuits.

(5) The SN65LVCP418 built-in passive input equalizer compensates for ISI. For a 25-inch FR4 transmission line with 8-mil trace width, the LVCP418 typically reduces jitter by 33 ps from the device input to the device output.

(6) Absolute deterministic output jitter reflects the deterministic jitter measured at the SN65LVCP418 output. The value is a real measured value with a Bit error tester as described in [Figure 8](#). The absolute DJ reflects the sum of all deterministic jitter components accumulated over the link:  $DJ_{(absolute)} = DJ_{(Signal\ generator)} + DJ_{(transmission\ line)} + DJ_{(intrinsic(LVCP418))}$ .

PARAMETER MEASUREMENT INFORMATION

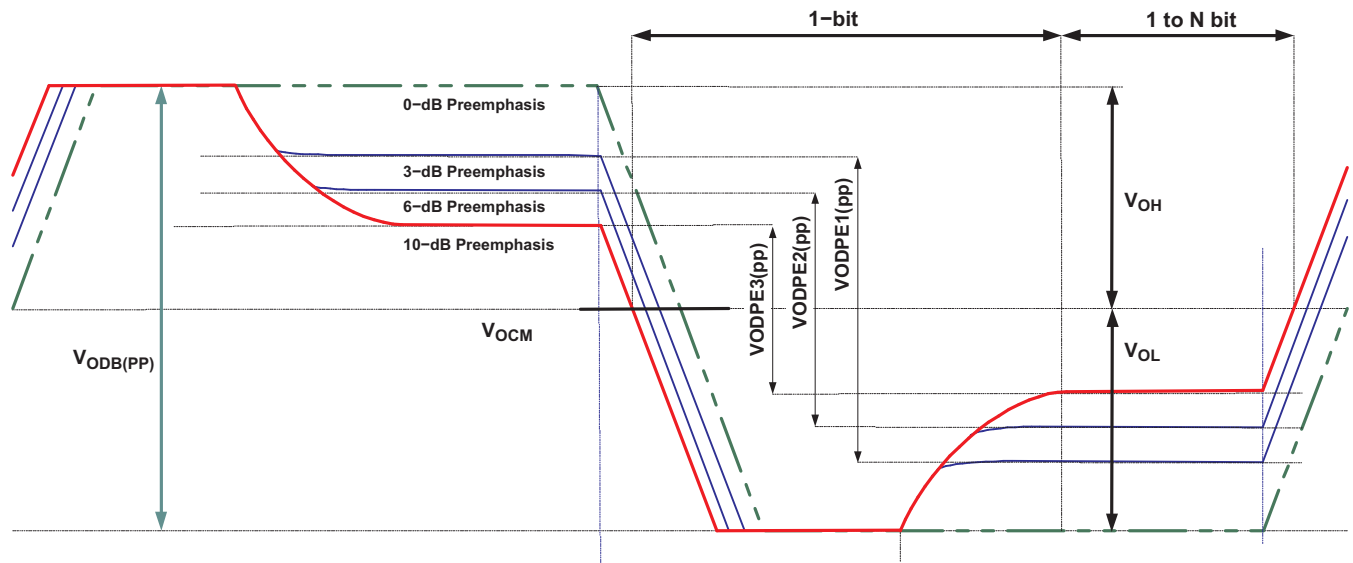

Figure 3. Preemphasis and Output Voltage Waveforms and Definitions

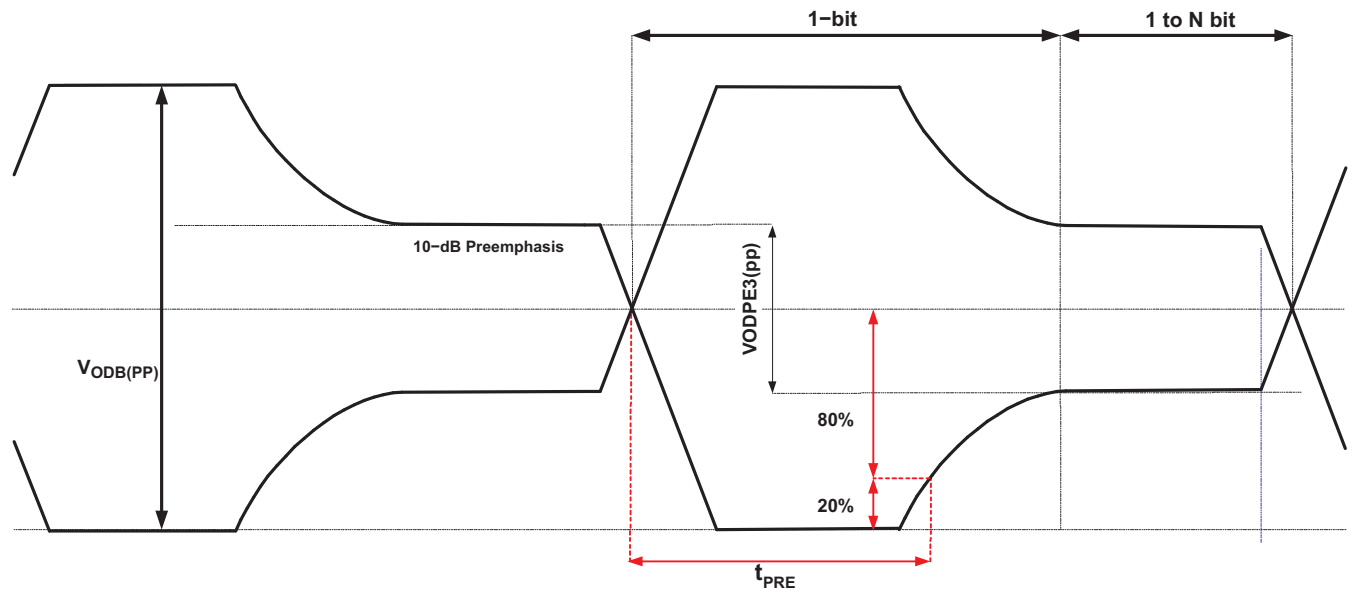

Figure 4.  $t_{PRE}$  Preemphasis Duration Measurement

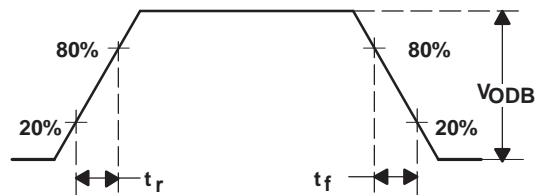

Figure 5. Driver Output Transition Time

PARAMETER MEASUREMENT INFORMATION (continued)

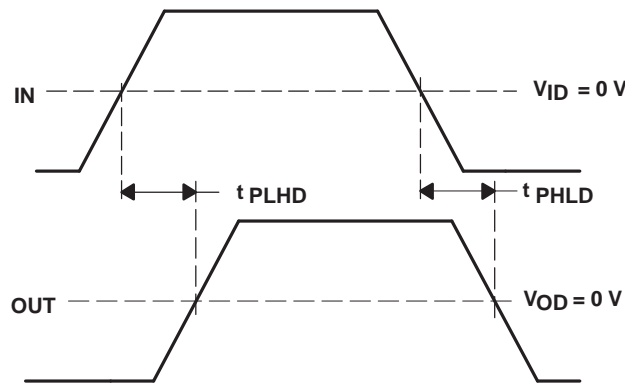
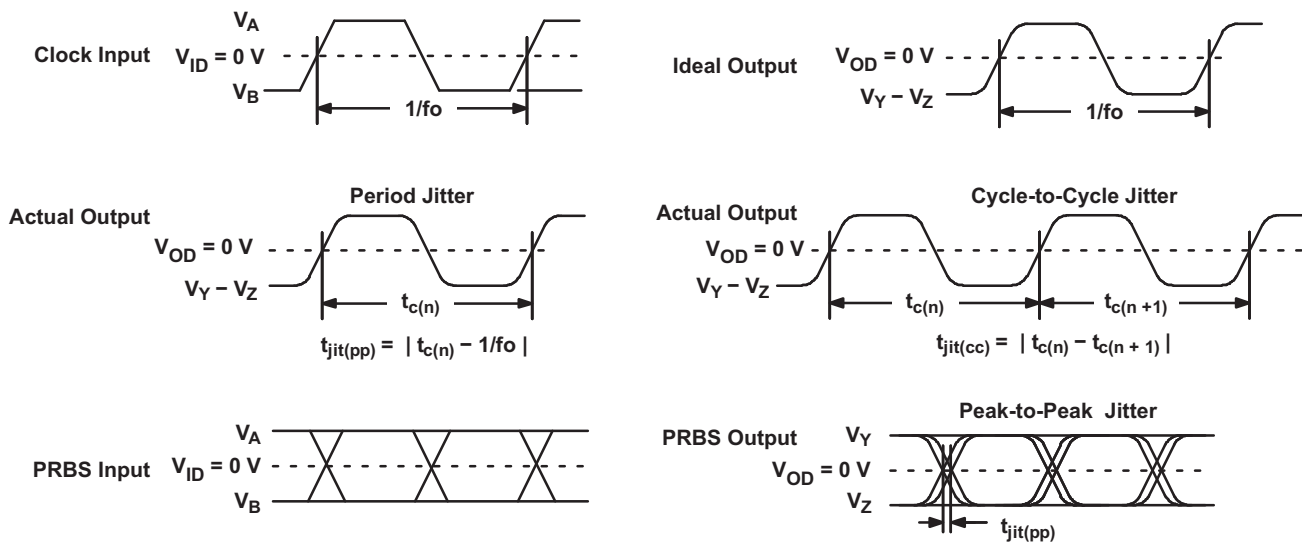
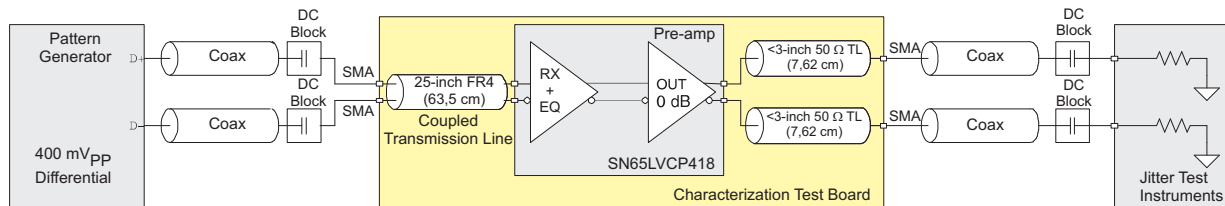

Figure 6. Propagation Delay Input to Output



- A. All input pulses are supplied by an Agilent 81250 Stimulus System.
- B. The measurement is made with the AgilentParBert measurement software.

Figure 7. Driver Jitter Measurement Waveforms



For the rise/fall time measurements, the 25-inch FR4 transmission line is removed.

Figure 8. AC Test Circuit — Jitter and Output Rise Time Test Circuit

The SN65LVCP418 input equalizer provides frequency gain to compensate for frequency loss of a shorter backplane transmission line. For characterization purposes, a 25-inch (63,5 cm) FR-4 coupled transmission line is used in place of the backplane trace. The 25-inch trace provides roughly 5 dB of attenuation between 375 MHz and 2.125 GHz, representing closely the characteristics of a short backplane trace. The loss tangent of the FR4 in the test board is 0.018 with an effective  $\epsilon(r)$  of 4.1.

TYPICAL DEVICE BEHAVIOR

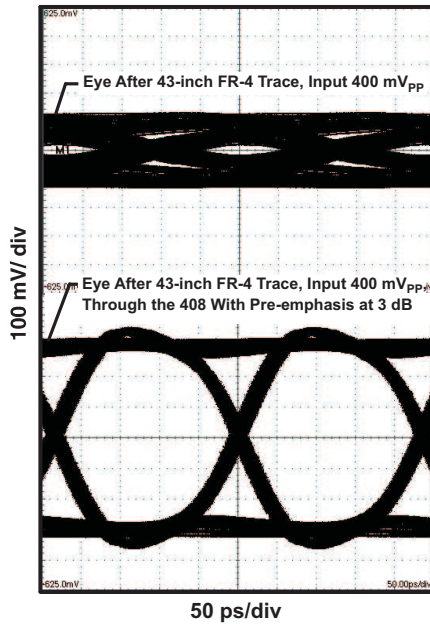

Figure 9. Data Input and Output Pattern

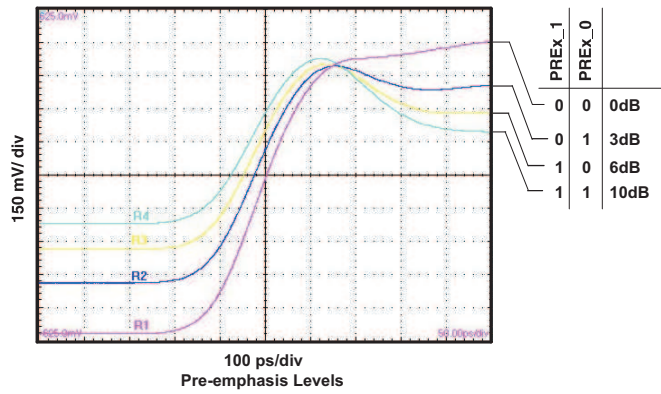

Figure 10. Preemphasis Signal Shape

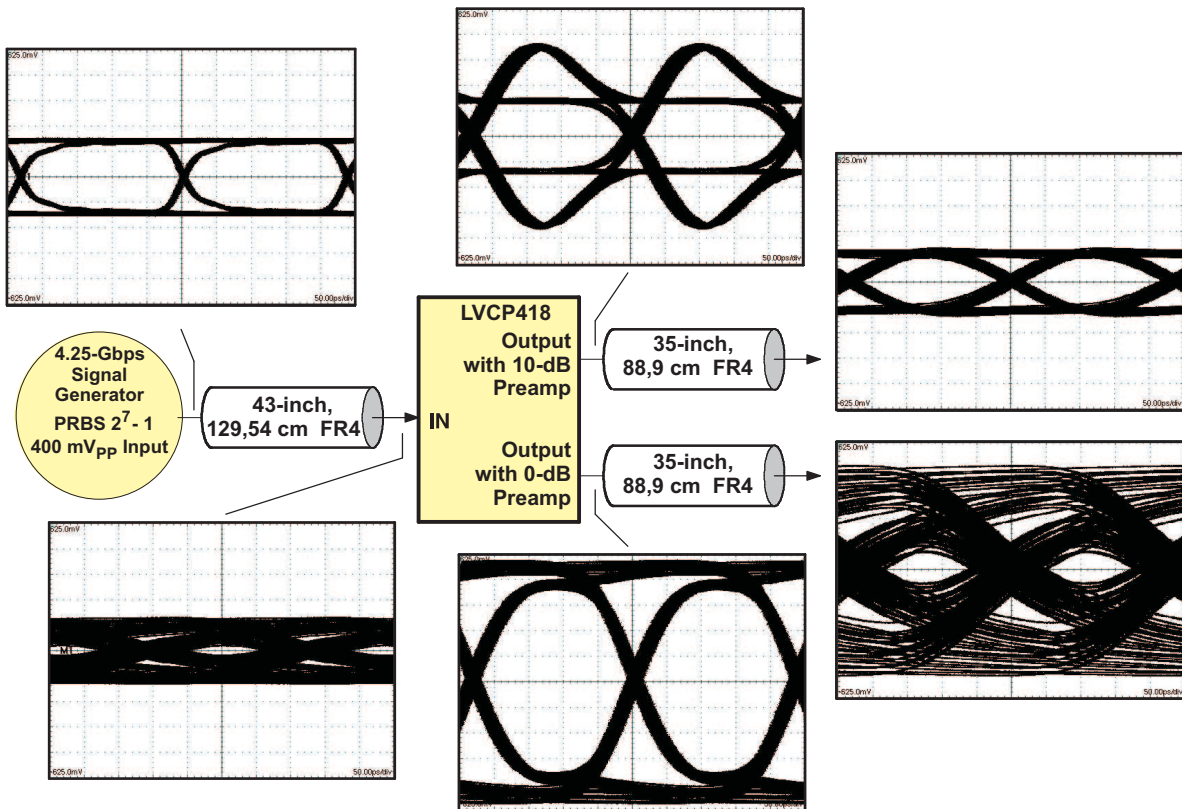

Figure 11. Data Output Pattern

TYPICAL CHARACTERISTICS

DETERMINISTIC OUTPUT JITTER vs DATA RATE

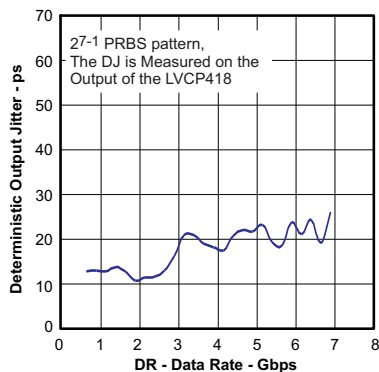

Figure 12.

DETERMINISTIC OUTPUT JITTER vs DIFFERENTIAL INPUT AMPLITUDE

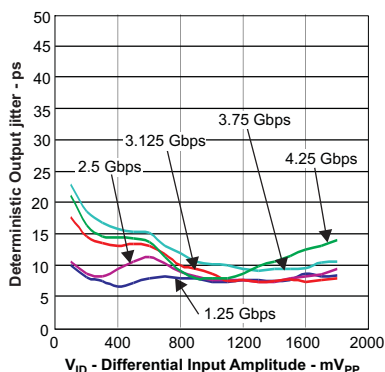

Figure 13.

DIFFERENTIAL OUTPUT VOLTAGE vs DATA RATE

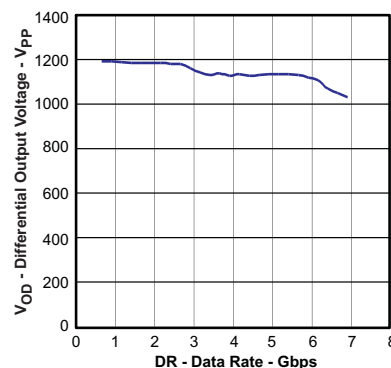

Figure 14.

SUPPLY NOISE vs DETERMINISTIC JITTER vs DATA RATE

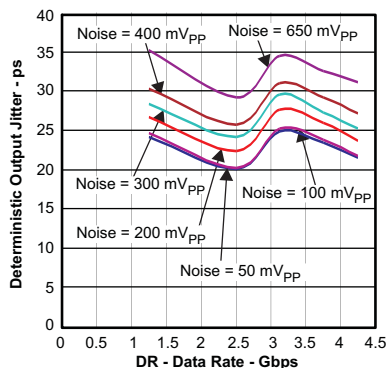

Figure 15.

DETERMINISTIC OUTPUT JITTER vs COMMON-MODE INPUT VOLTAGE

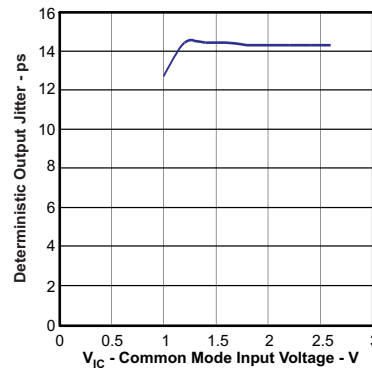

Figure 16.

## I<sup>2</sup>C CONTROL INTERFACE

### I<sup>2</sup>C Interface Notes

The I<sup>2</sup>C interface is used to access the internal registers of the SN65LVCP418. I<sup>2</sup>C is a two-wire serial interface developed by Philips Semiconductor (see I<sup>2</sup>C-Bus Specification, Version 2.1, January 2000). The bus consists of a data line (SDA) and a clock line (SCL) with pull-up structures. When the bus is idle, both SDA and SCL lines are pulled high. All the I<sup>2</sup>C compatible devices connect to the I<sup>2</sup>C bus through open drain I/O pins, SDA and SCL. A master device, usually a microcontroller or a digital signal processor, controls the bus. The master is responsible for generating the SCL signal and device addresses. The master also generates specific conditions that indicate the START and STOP of data transfer. A slave device receives and/or transmits data on the bus under control of the master device. The SN65LVCP418 works as a slave and supports the standard mode transfer (100 kbps).

The basic I<sup>2</sup>C start and stop access cycles are shown in Figure 17. The basic access cycle consists of the following:

- A start condition
- A slave address cycle
- Any number of data cycles
- A stop condition

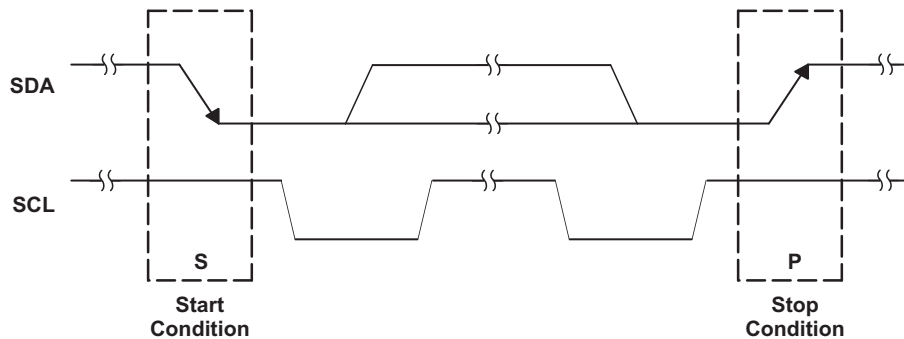

Figure 17. I<sup>2</sup>C Start and Stop Conditions

### General I<sup>2</sup>C Protocol

- The master initiates data transfer by generating a start condition. The start condition is when a high-to-low transition occurs on the SDA line while SCL is high, as shown in Figure 17. All I<sup>2</sup>C-compatible devices should recognize a start condition.
- The master then generates the SCL pulses and transmits the 7-bit address and the read/write direction bit R/W on the SDA line. During all transmissions, the master ensures that data is valid. A valid data condition requires the SDA line to be stable during the entire high period of the clock pulse (see Figure 18). All devices recognize the address sent by the master and compare it to their internal fixed addresses. Only the slave device with a matching address generates an acknowledge (see Figure 19) by pulling the SDA line low during the entire high period of the ninth SCL cycle. On detecting this acknowledge, the master knows that a communication link with a slave has been established.
- The master generates further SCL cycles to either transmit data to the slave (R/W bit 0) or receive data from the slave (R/W bit 1). In either case, the receiver needs to acknowledge the data sent by the transmitter. So an acknowledge signal can either be generated by the master or by the slave, depending on which one is the receiver. The 9-bit valid data sequences consisting of 8-bit data and 1-bit acknowledge can continue as long as necessary (see Figure 20).
- To signal the end of the data transfer, the master generates a stop condition by pulling the SDA line from low to high while the SCL line is high (see Figure 17). This releases the bus and stops the communication link with the addressed slave. All I<sup>2</sup>C compatible devices must recognize the stop condition. Upon the receipt of a stop condition, all devices know that the bus is released, and they wait for a start condition followed by a matching address.
- All bytes are transmitted most significant bit first.

Table 1. I<sup>2</sup>C Timing

PARAMETER	TEST CONDITIONS	MIN	TYP	MAX	UNIT
f <sub>SCL</sub>	SCL clock frequency for internal register			100	kHz
t <sub>W(L)</sub>	Clock LOW period for I <sup>2</sup> C register	4.7			μs
t <sub>W(H)</sub>	Clock HIGH period for internal register	4			μs
t <sub>SU1</sub>	Internal register setup time, SDA to SCL	250			μs
t <sub>h(1)</sub>	Internal register hold time, SCL to SDA	0			μs
t <sub>(buf)</sub>	Internal register bus free time between STOP and START	4.7			μs
t <sub>SU(2)</sub>	Internal register setup time, SCL to START	4.7			μs
t <sub>h(2)</sub>	Internal register hold time, START to SCL	4			μs
t <sub>SU(3)</sub>	Internal register hold time, SCL to STOP	4			μs

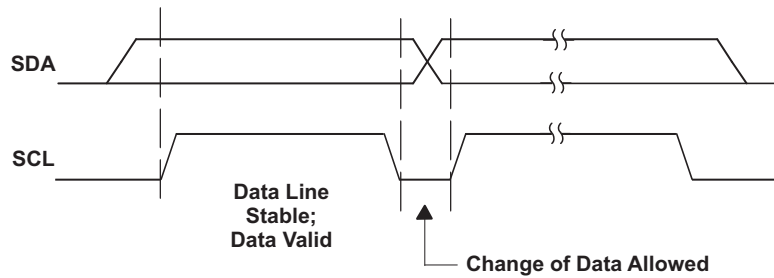

Figure 18. I<sup>2</sup>C Bit Transfer

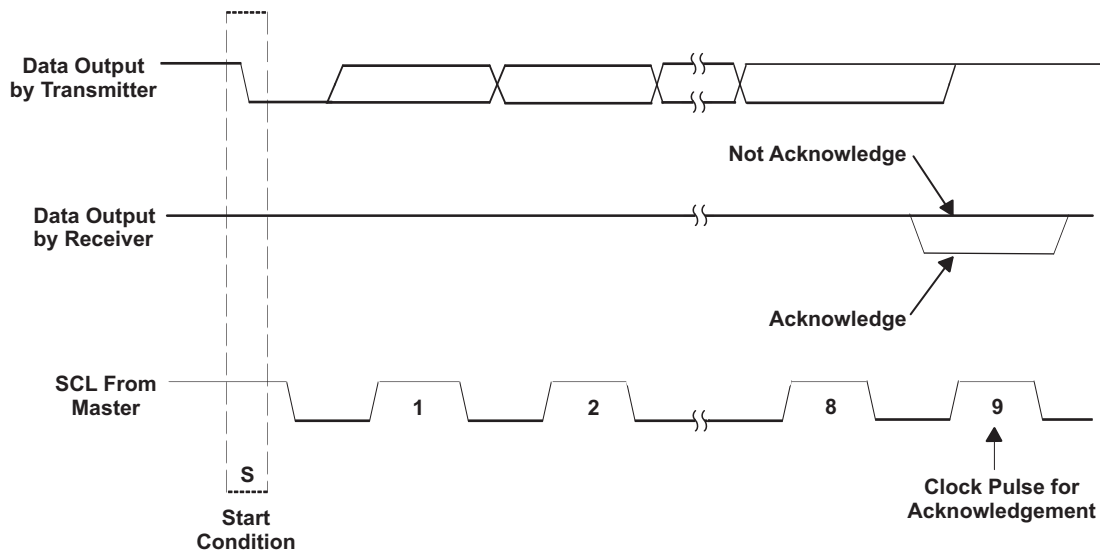

Figure 19. I<sup>2</sup>C Acknowledge

Note: Following power up, this device must be reset.

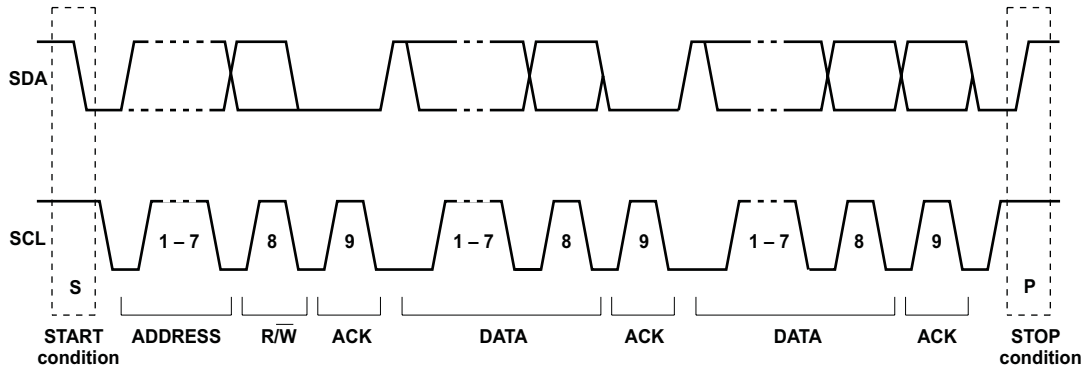

Figure 20. I<sup>2</sup>C Address and Data Cycles

During a write cycle, the slave sends an acknowledge (A) after every byte that follows the device address. The first byte following the device address is the register address, which maps to the register addresses specific to the device. The second byte following the device address is the data byte to be written at the register address (see Figure 21). If only the register address is to be written for a subsequent read sequence, the data byte is omitted and the sequence ends with a Stop (see Figure 22) or a repeated Start after the register address byte (see Figure 24). If multiple data bytes are to be written at subsequent register addresses, the master may continue to send data bytes after each slave acknowledge, and the slave device automatically increments the register address. Note that the master must not drive the SDA signal line during the slave acknowledge since the slave is in control of the SDA bus and may be holding it low.

During a read cycle, the slave acknowledges the initial address byte if it decodes the device address as its own device address. Following this initial acknowledge by the slave, the master device becomes a receiver and acknowledges data bytes sent by the slave. The first byte received by the master is the data stored at the register address, while subsequent bytes are data stored at incrementing register addresses. When the master has received all of the requested data bytes from the slave, the not acknowledge (A) condition is initiated by the master by keeping the SDA signal high just before it asserts the Stop (P) condition. This sequence terminates a read cycle as shown in Figure 23. A combined format is when the read cycle is preceded by a write cycle for setting the register address, and is shown in Figure 24.

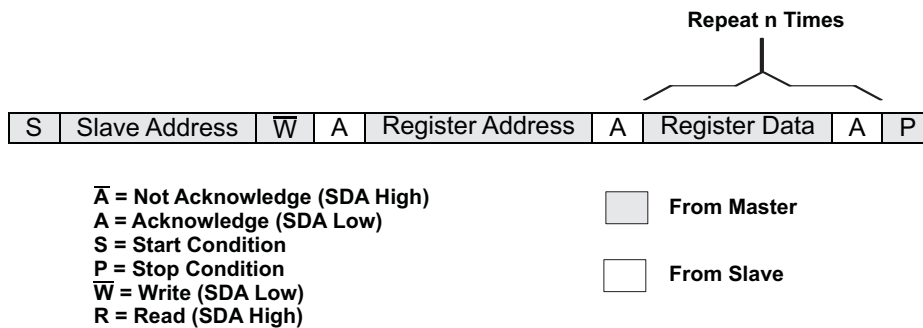

Figure 21. I<sup>2</sup>C Write Cycle with Register Address and Data

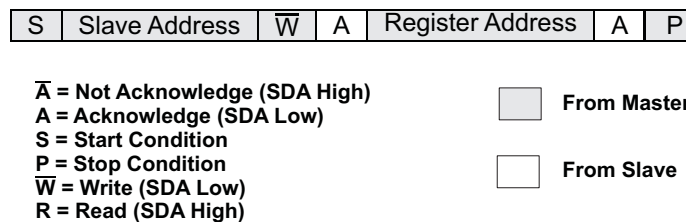

Figure 22. I<sup>2</sup>C Write Cycle with Register Address Only

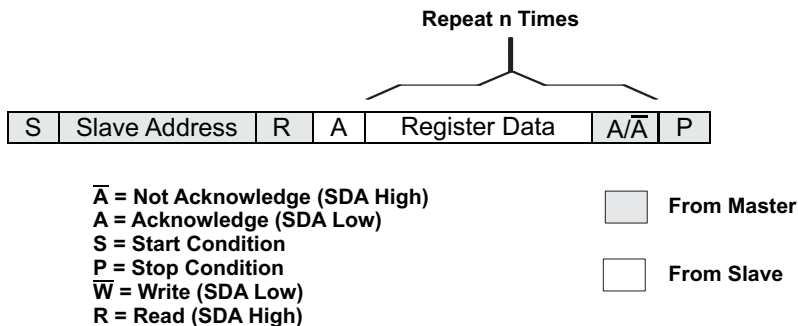

Figure 23. I<sup>2</sup>C Read Cycle

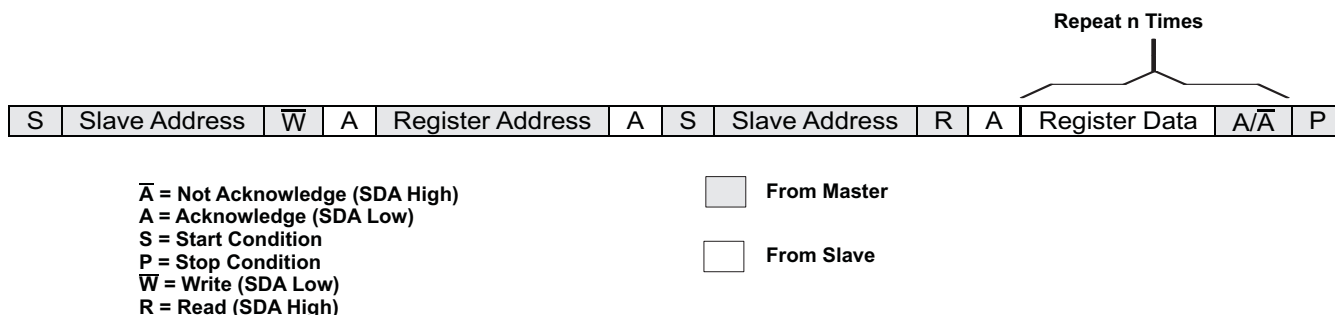

Figure 24. I<sup>2</sup>C Combined Format Write/Read Cycle

### Slave Address

Both SDA and SCL must be connected to a positive supply voltage via a pull-up resistor. These resistors should comply with the I<sup>2</sup>C specification that ranges from 2 kΩ to 19 kΩ. When the bus is free, both lines are high. The slave address is the first 7 bits received following the START condition from the master device. The first 5 Bits (MSBs) of the address are factory preset to 01011. The next two bits of the SN65LVCP408 address are controlled by the logic levels appearing on the ADDR2 and ADDR1 pins. The ADDR2 and ADDR1 address inputs can be connected to VCC for logic 1, GND for logic 0, or can be actively driven by TTL/CMOS logic levels. The device addresses are set by the state of these pins and are not latched. Thus a dynamic address control system could be utilized to incorporate several devices on the same system. Up to four SN65LVCP408 devices can be connected to the same I<sup>2</sup>C-Bus without requiring additional glue logic. Table 2 lists the possible addresses for the SN65LVCP408.

Table 2. Slave Addresses

Fixed Address			Fixed Address		Selectable with Address Pins		
Bit 7 (MSB)	Bit 6	Bit 5	Bit 4	Bit 3	Bit 2	Bit 1 (addr2)	Bit 0 (addr1)
0	1	0	1	1	0	0	0
0	1	0	1	1	0	0	1
0	1	0	1	1	0	1	0
0	1	0	1	1	0	1	1

Note: Following power up, this device must be reset.

**Table 3. Port Register Addresses**

Register Name	Register Address
Output Port 0	0000 0000
Output Port 1	0000 0001
Output Port 2	0000 0010
Output Port 3	0000 0011
Output Port 4	0000 0100
Output Port 5	0000 0101
Output Port 6	0000 0110
Output Port 7	0000 0111
Input Port 0	0000 1000
Input Port 1	0000 1001
Input Port 2	0000 1010
Input Port 3	0000 1011
Input Port 4	0000 1100
Input Port 5	0000 1101
Input Port 6	0000 1110
Input Port 7	0000 1111
Reserved for TI use only	0000 0001 to 0001 1001

**Table 4. Output Port Control Registers**

Bit	Function	Default	Note	ACCESS
7	RSVD	0	Reserved	R/W
6		0		
5		0		
4	Pre-Emphasis	00	Pre-emphasis setting. Valid values are: 00 = 0 dB; 01 = 3 dB; 10 = 6 dB, and 11 = 10 dB. Note: When EN = 0, then the PRE pin is used to set the pre-emphasis setting rather than the I <sup>2</sup> C register map.	R/W
3				
2	Port 3-State	0	3-State Off = 0; 3-State On = 1	R/W
1	RSVD	0	Reserved	R
0	RSVD	0	Reserved	

**Table 5. Input Port Control Registers**

Bit	Function	Default	Note	Access
7	Rx Equalization Select	0	Rx Equalization Setting; 0 = 13 dB; 1=9dB; Note: When EN=0 then the EQ pin is used to set the Equalization setting rather than the I <sup>2</sup> C register map.	R/W
6	RSVD	0	Reserved	
5	RSVD	0	Reserved	
4	RSVD	0	Reserved	
3	RSVD	0	Reserved	R
2	RSVD	0	Reserved	
1	RSVD	0	Reserved	
0	RSVD	0	Reserved	

Note: Following power up, this device must be reset.

**Table 6. Reserved For TI Use (0001 0000)**

Bit	Function	Default	Note	Access
5:6	RSVD	–	Reserved	R/W
5:1	RSVD	–	Reserved	R

**Table 7. Reserved For TI Use (0001 0001 to 0001 1010)**

Bit	Function	Default	Note	Access
7:0	RSVD	–	Read only. Value is indeterministic.	R

**APPLICATION INFORMATION**

**BANDWIDTH REQUIREMENTS**

Error free transmission of data over a transmission line has specific bandwidth demands. It is helpful to analyze the frequency spectrum of the transmit data first. For an 8B10B coded data stream at 3.75 Gbps of random data, the highest bit transition density occurs with a 1010 pattern (1.875 GHz). The least transition density in 8B10B allows for five consecutive ones or zeros. Hence, the lowest frequency of interest is 1.875 GHz/5 = 375 MHz. Real data signals consist of higher frequency components than sine waves due to the fast rise time. The faster the rise time, the more bandwidth becomes required. For 80-ps rise time, the highest important frequency component is at least  $0.6/(\pi \times 80 \text{ ps}) = 2.4 \text{ GHz}$ . Figure 25 shows the Fourier transformation of the 375-MHz and 1.875-GHz trapezoidal signal.

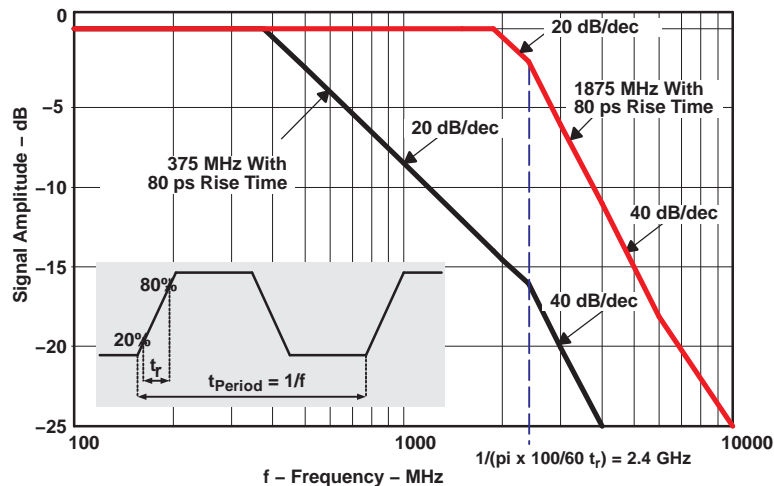

**Figure 25. Approximate Frequency Spectrum of the Transmit Output Signal With 80 ps Rise Time**

The spectrum analysis of the data signal suggests building a backplane with little frequency attenuation up to 2 GHz. This is achievable only with expensive, specialized PCB material. To support material like FR4, a compensation technique is necessary to compensate for backplane imperfections.

## EXPLANATION OF EQUALIZATION

Backplane designs differ widely in size, layer stack-up, and connector placement. In addition, the performance is impacted by trace architecture (trace width, coupling method) and isolation from adjacent signals. Common to most commercial backplanes is the use of FR4 as board material and its related high-frequency signal attenuation. Within a backplane, the shortest to longest trace lengths differ substantially – often ranging from 8 inches up to 40 inches. Increased loss is associated with longer signal traces. In addition, the backplane connector often contributes a good amount of signal attenuation. As a result, the frequency signal attenuation for a 300-MHz signal might range from 1 dB to 4 dB while the corresponding attenuation for a 2-GHz signal might span 6 dB to 24 dB. This frequency dependent loss causes distortion jitter on the transmitted signal. Each LVCP418 receiver input incorporates an equalizer and compensates for such frequency loss. The SN65LVCP418 equalizer provides 5 dB of frequency gain between 375 MHz and 1.875 GHz, compensating roughly for 20 inches of FR4 material with 8-mil trace width. Distortion jitter improvement is substantial, often providing more than 30-ps jitter reduction. The 5-dB compensation is sufficient for most short backplane traces. For longer trace lengths, it is recommended to enable transmit preemphasis in addition.

## SETTING THE PREEMPHASIS LEVEL

The receive equalization compensates for ISI. This reduces jitter and opens the data eye. In order to find the best preemphasis setting for each link, calibration of every link is recommended. Assuming each link consists of a transmitter (with adjustable pre-emphasis such as LVCP418) and the LVCP418 receiver, the following steps are necessary:

1. Set the transmitter and receiver to 0-dB preemphasis; record the data eye on the LVCP418 receiver output.
2. Increase the transmitter preemphasis until the data eye on the LVCP418 receiver output looks the cleanest.



## REVISION HISTORY

### Changes from Original (June 2009) to Revision A

Page

- | Changes from Original (June 2009) to Revision A  | Page |
|--|------|
| • Changed <a href="#">Table 4</a> , row - Port 3-State From: Access = R To: Access = R/W ..... | 16   |

**PACKAGING INFORMATION**

Orderable Device	Status (1)	Package Type	Package Drawing	Pins	Package Qty	Eco Plan (2)	Lead finish/ Ball material (6)	MSL Peak Temp (3)	Op Temp (°C)	Device Marking (4/5)	Samples
SN65LVCP418PAPR	ACTIVE	HTQFP	PAP	64	1000	RoHS & Green	NIPDAU	Level-3-260C-168 HR	-40 to 85	LVCP418	
SN65LVCP418PAPT	ACTIVE	HTQFP	PAP	64	250	RoHS & Green	NIPDAU	Level-3-260C-168 HR	-40 to 85	LVCP418	

(1) The marketing status values are defined as follows:

**ACTIVE:** Product device recommended for new designs.

**LIFEBUY:** TI has announced that the device will be discontinued, and a lifetime-buy period is in effect.

**NRND:** Not recommended for new designs. Device is in production to support existing customers, but TI does not recommend using this part in a new design.

**PREVIEW:** Device has been announced but is not in production. Samples may or may not be available.

**OBSOLETE:** TI has discontinued the production of the device.

(2) **RoHS:** TI defines "RoHS" to mean semiconductor products that are compliant with the current EU RoHS requirements for all 10 RoHS substances, including the requirement that RoHS substance do not exceed 0.1% by weight in homogeneous materials. Where designed to be soldered at high temperatures, "RoHS" products are suitable for use in specified lead-free processes. TI may reference these types of products as "Pb-Free".

**RoHS Exempt:** TI defines "RoHS Exempt" to mean products that contain lead but are compliant with EU RoHS pursuant to a specific EU RoHS exemption.

**Green:** TI defines "Green" to mean the content of Chlorine (Cl) and Bromine (Br) based flame retardants meet JS709B low halogen requirements of <=1000ppm threshold. Antimony trioxide based flame retardants must also meet the <=1000ppm threshold requirement.

(3) MSL, Peak Temp. - The Moisture Sensitivity Level rating according to the JEDEC industry standard classifications, and peak solder temperature.

(4) There may be additional marking, which relates to the logo, the lot trace code information, or the environmental category on the device.

(5) Multiple Device Markings will be inside parentheses. Only one Device Marking contained in parentheses and separated by a "~" will appear on a device. If a line is indented then it is a continuation of the previous line and the two combined represent the entire Device Marking for that device.

(6) Lead finish/Ball material - Orderable Devices may have multiple material finish options. Finish options are separated by a vertical ruled line. Lead finish/Ball material values may wrap to two lines if the finish value exceeds the maximum column width.

**Important Information and Disclaimer:**The information provided on this page represents TI's knowledge and belief as of the date that it is provided. TI bases its knowledge and belief on information provided by third parties, and makes no representation or warranty as to the accuracy of such information. Efforts are underway to better integrate information from third parties. TI has taken and continues to take reasonable steps to provide representative and accurate information but may not have conducted destructive testing or chemical analysis on incoming materials and chemicals. TI and TI suppliers consider certain information to be proprietary, and thus CAS numbers and other limited information may not be available for release.

In no event shall TI's liability arising out of such information exceed the total purchase price of the TI part(s) at issue in this document sold by TI to Customer on an annual basis.



**TAPE AND REEL INFORMATION**

**QUADRANT ASSIGNMENTS FOR PIN 1 ORIENTATION IN TAPE**

\*All dimensions are nominal

Device	Package Type	Package Drawing	Pins	SPQ	Reel Diameter (mm)	Reel Width W1 (mm)	A0 (mm)	B0 (mm)	K0 (mm)	P1 (mm)	W (mm)	Pin1 Quadrant
SN65LVCP418PAPR	HTQFP	PAP	64	1000	330.0	24.4	13.0	13.0	1.5	16.0	24.0	Q2

**TAPE AND REEL BOX DIMENSIONS**

\*All dimensions are nominal

Device	Package Type	Package Drawing	Pins	SPQ	Length (mm)	Width (mm)	Height (mm)
SN65LVCP418PAPR	HTQFP	PAP	64	1000	350.0	350.0	43.0

## GENERIC PACKAGE VIEW

**PAP 64**

**HTQFP - 1.2 mm max height**

10 x 10, 0.5 mm pitch

QUAD FLATPACK

This image is a representation of the package family, actual package may vary.  
Refer to the product data sheet for package details.

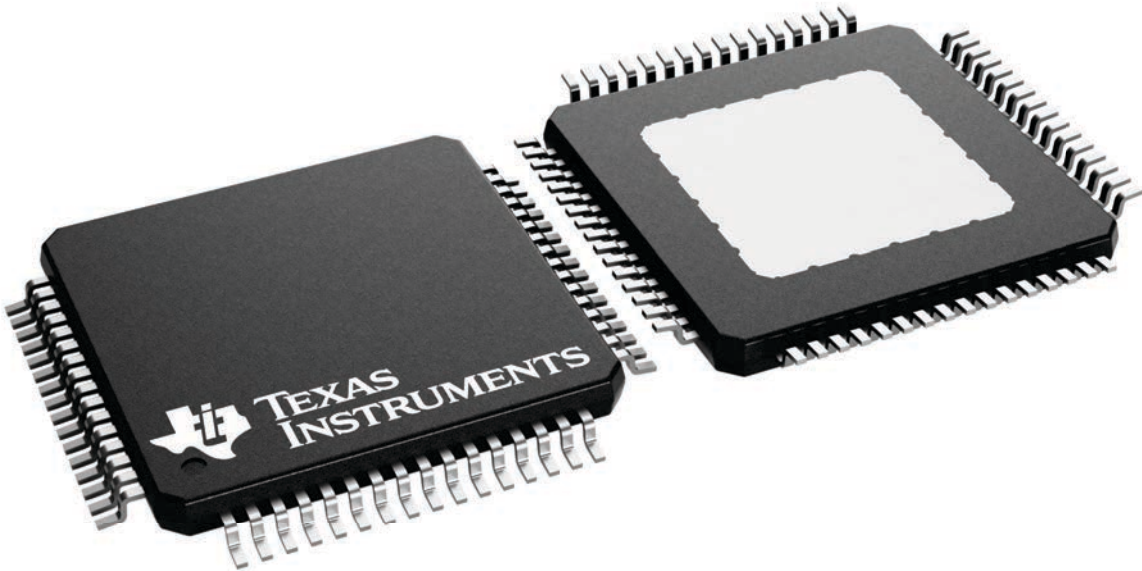

4226442/A

PAP (S-PQFP-G64)

PowerPAD™ PLASTIC QUAD FLATPACK

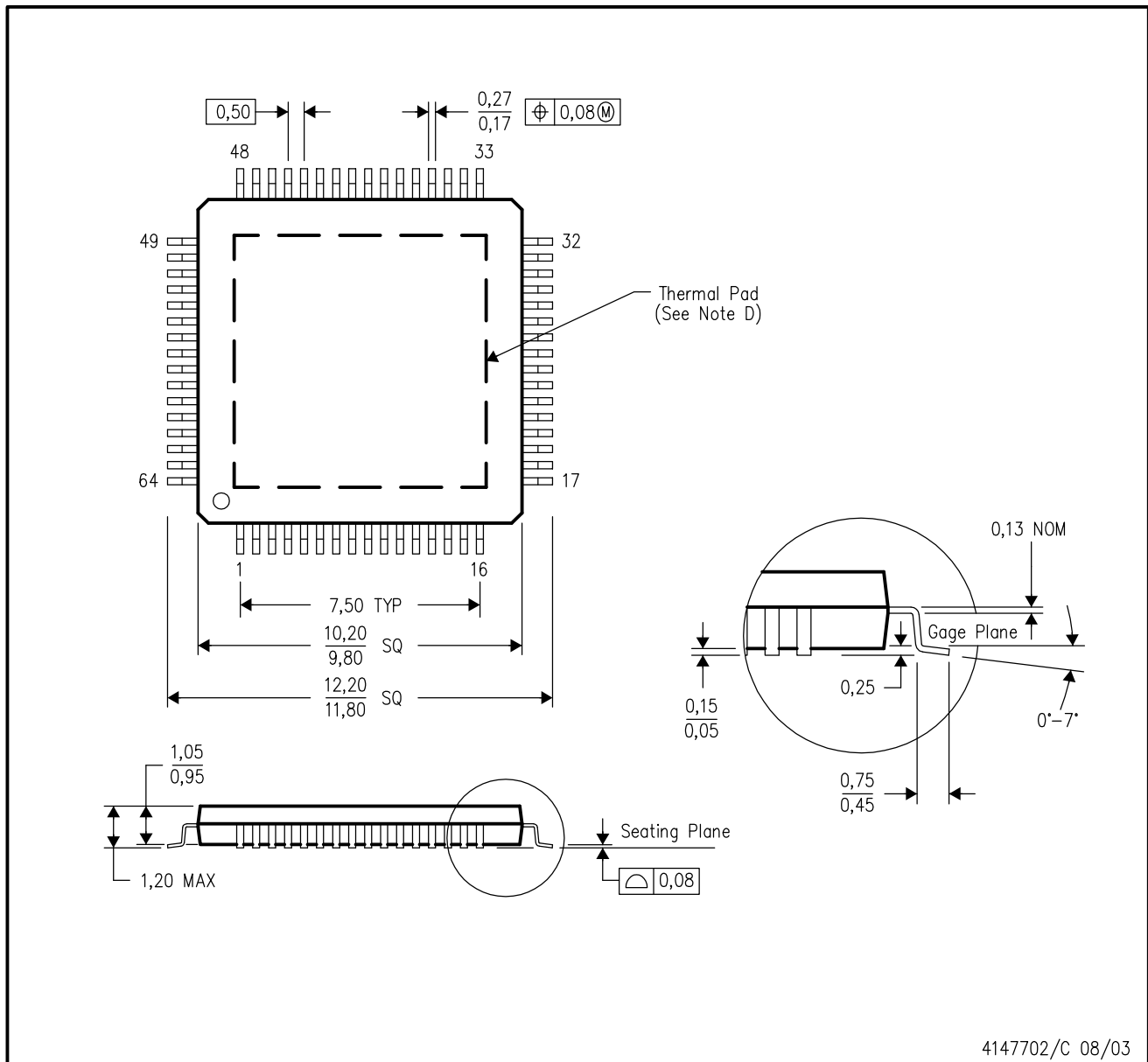

- NOTES:
- A. All linear dimensions are in millimeters.
  - B. This drawing is subject to change without notice.
  - C. Body dimensions do not include mold flash or protrusion
  - D. This package is designed to be soldered to a thermal pad on the board. Refer to Technical Brief, PowerPad Thermally Enhanced Package, Texas Instruments Literature No. SLMA002 for information regarding recommended board layout. This document is available at [www.ti.com](http://www.ti.com) <<http://www.ti.com>>.
  - E. Falls within JEDEC MS-026

PowerPAD is a trademark of Texas Instruments.

## THERMAL PAD MECHANICAL DATA

PAP (S-PQFP-G64)

PowerPAD™ PLASTIC QUAD FLATPACK

### THERMAL INFORMATION

This PowerPAD™ package incorporates an exposed thermal pad that is designed to be attached to a printed circuit board (PCB). The thermal pad must be soldered directly to the PCB. After soldering, the PCB can be used as a heatsink. In addition, through the use of thermal vias, the thermal pad can be attached directly to the appropriate copper plane shown in the electrical schematic for the device, or alternatively, can be attached to a special heatsink structure designed into the PCB. This design optimizes the heat transfer from the integrated circuit (IC).

For additional information on the PowerPAD package and how to take advantage of its heat dissipating abilities, refer to Technical Brief, PowerPAD Thermally Enhanced Package, Texas Instruments Literature No. SLMA002 and Application Brief, PowerPAD Made Easy, Texas Instruments Literature No. SLMA004. Both documents are available at [www.ti.com](http://www.ti.com).

The exposed thermal pad dimensions for this package are shown in the following illustration.

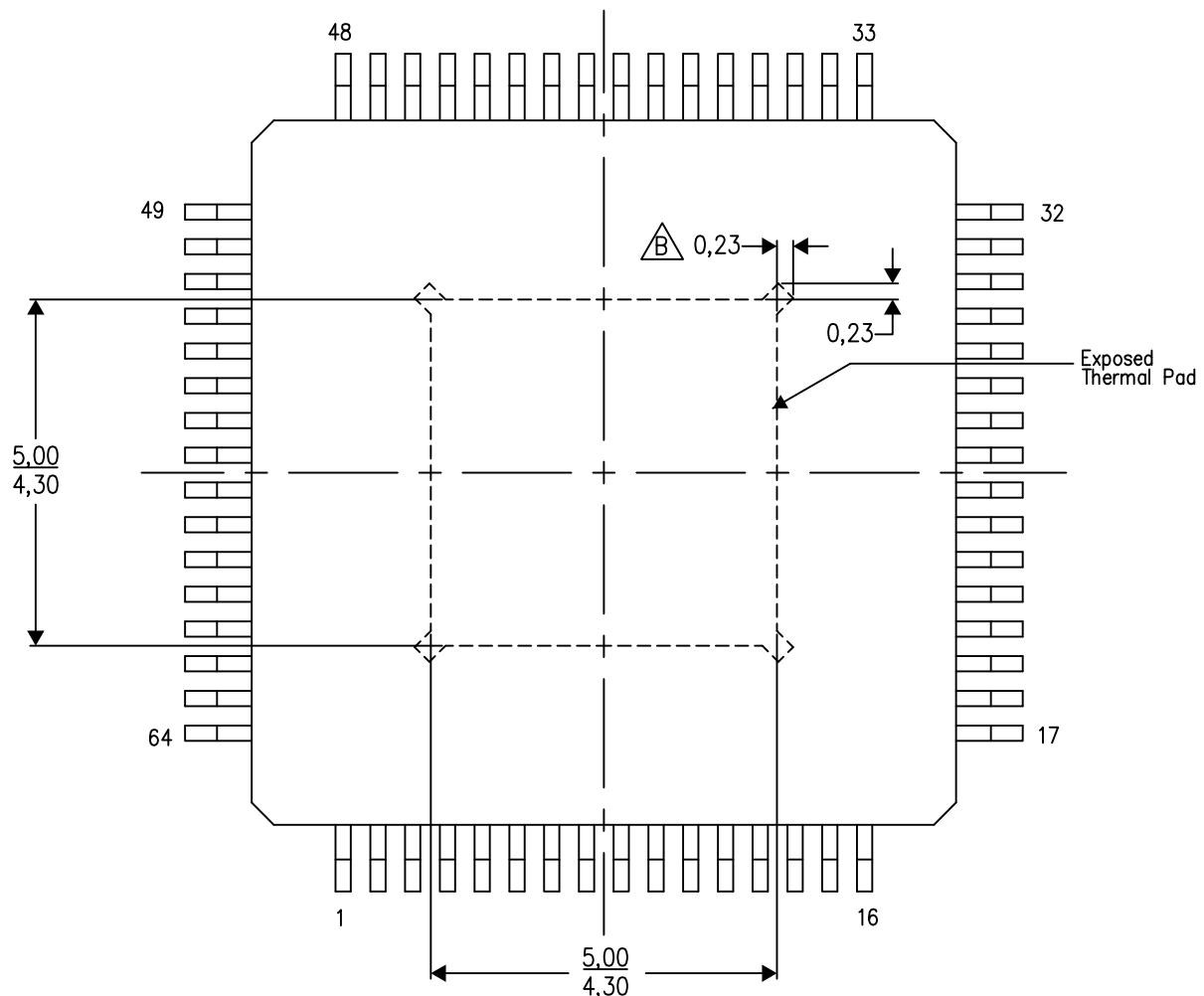

Top View  
Exposed Thermal Pad Dimensions

4206326-3/P 05/14

NOTES: A. All linear dimensions are in millimeters

 Tie strap features may not be present.

PowerPAD is a trademark of Texas Instruments

# LAND PATTERN DATA

PAP (S-PQFP-G64)

PowerPAD™ PLASTIC QUAD FLATPACK

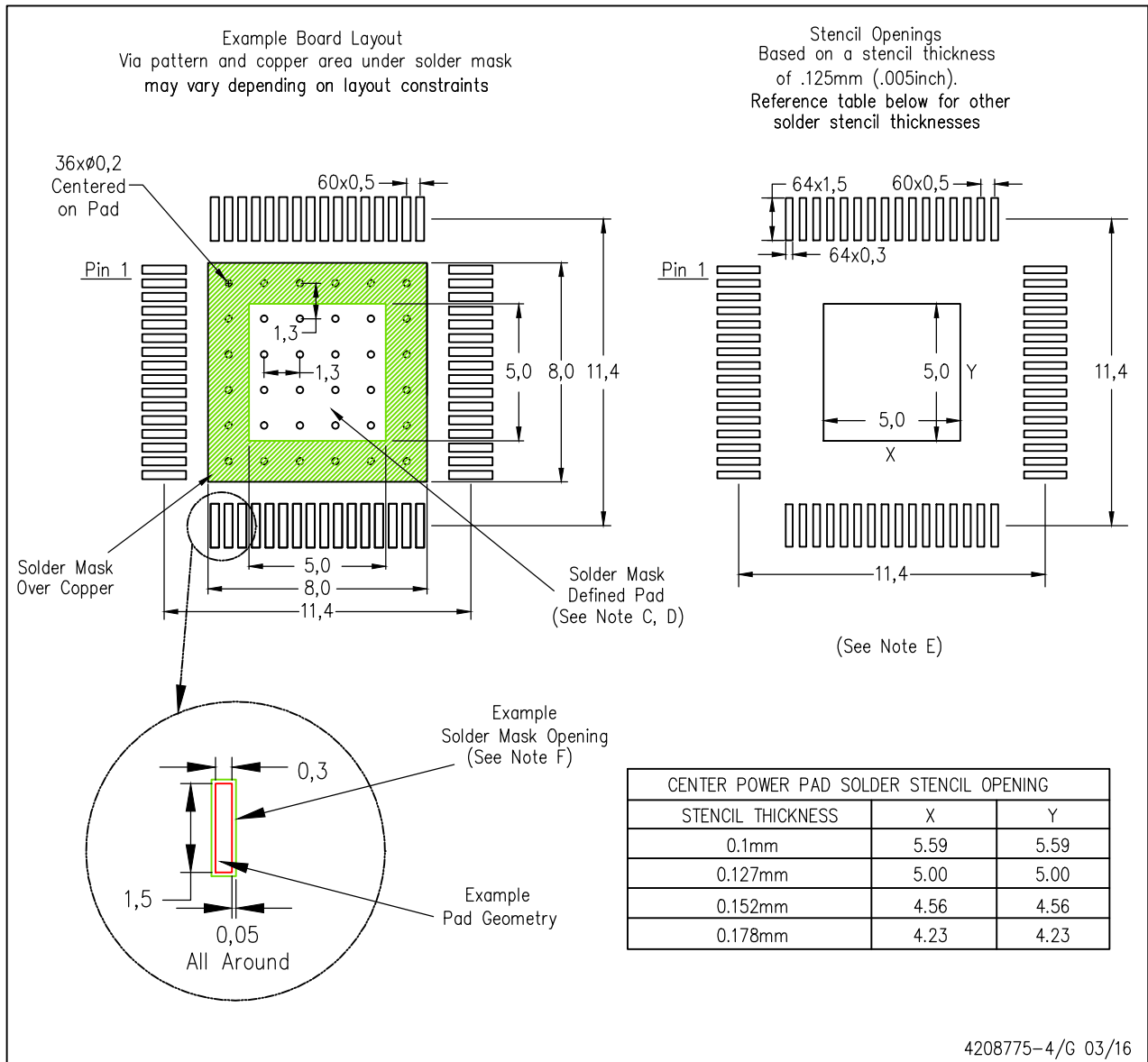

- NOTES:
- A. All linear dimensions are in millimeters.
  - B. This drawing is subject to change without notice.
  - C. Customers should place a note on the circuit board fabrication drawing not to alter the center solder mask defined pad.
  - D. This package is designed to be soldered to a thermal pad on the board. Refer to Technical Brief, PowerPad Thermally Enhanced Package, Texas Instruments Literature No. SLMA002, SLMA004, and also the Product Data Sheets for specific thermal information, via requirements, and recommended board layout. These documents are available at [www.ti.com](http://www.ti.com) <<http://www.ti.com>>. Publication IPC-7351 is recommended for alternate designs.
  - E. Laser cutting apertures with trapezoidal walls and also rounding corners will offer better paste release. Customers should contact their board assembly site for stencil design recommendations. Example stencil design based on a 50% volumetric metal load solder paste. Refer to IPC-7525 for other stencil recommendations.
  - F. Customers should contact their board fabrication site for solder mask tolerances between and around signal pads.
- PowerPAD is a trademark of Texas Instruments**

## IMPORTANT NOTICE AND DISCLAIMER

TI PROVIDES TECHNICAL AND RELIABILITY DATA (INCLUDING DATA SHEETS), DESIGN RESOURCES (INCLUDING REFERENCE DESIGNS), APPLICATION OR OTHER DESIGN ADVICE, WEB TOOLS, SAFETY INFORMATION, AND OTHER RESOURCES "AS IS" AND WITH ALL FAULTS, AND DISCLAIMS ALL WARRANTIES, EXPRESS AND IMPLIED, INCLUDING WITHOUT LIMITATION ANY IMPLIED WARRANTIES OF MERCHANTABILITY, FITNESS FOR A PARTICULAR PURPOSE OR NON-INFRINGEMENT OF THIRD PARTY INTELLECTUAL PROPERTY RIGHTS.

These resources are intended for skilled developers designing with TI products. You are solely responsible for (1) selecting the appropriate TI products for your application, (2) designing, validating and testing your application, and (3) ensuring your application meets applicable standards, and any other safety, security, regulatory or other requirements.

These resources are subject to change without notice. TI grants you permission to use these resources only for development of an application that uses the TI products described in the resource. Other reproduction and display of these resources is prohibited. No license is granted to any other TI intellectual property right or to any third party intellectual property right. TI disclaims responsibility for, and you will fully indemnify TI and its representatives against, any claims, damages, costs, losses, and liabilities arising out of your use of these resources.

TI's products are provided subject to [TI's Terms of Sale](#) or other applicable terms available either on [ti.com](http://ti.com) or provided in conjunction with such TI products. TI's provision of these resources does not expand or otherwise alter TI's applicable warranties or warranty disclaimers for TI products.

TI objects to and rejects any additional or different terms you may have proposed.

Mailing Address: Texas Instruments, Post Office Box 655303, Dallas, Texas 75265  
Copyright © 2022, Texas Instruments Incorporated

## Looking for pricing, stock, or lifecycle information?

Click below to explore more details on WIN SOURCE:

 [View SN65LVCP418PAPT on WIN SOURCE](#)

 [Texas Instruments](#) Information

## Optimize Your Supply Chain with WIN SOURCE Solutions

-  Global Sourcing Solution
-  Obsolete Management
-  Cost Control Management
-  Shortage Management
-  Alternative Solution
-  Excess Inventory Management