



THE DATASHEET OF SN65HVD255DEVM



SN65HVD25x Turbo CAN Transceivers for Higher Data Rates and Large Networks Including Features for Functional Safety

1 Features

- Meets the Requirements of ISO11898-2
- Turbo CAN:
 - Short and Symmetrical Propagation Delay Times and Fast Loop Times for Enhanced Timing Margin
 - Higher Data Rates in CAN Networks
- I/O Voltage Range Supports 3.3-V and 5-V MCUs
- Ideal Passive Behavior When Unpowered
 - Bus and Logic Pins are High Impedance (No Load)
 - Power Up and Power Down With Glitch-Free Operation on Bus
- Protection Features
 - HBM ESD Protection Exceeds ± 12 kV
 - Bus Fault Protection -27 V to 40 V
 - Undervoltage Protection on Supply Pins
 - Driver Dominant Time Out (TXD DTO)
 - SN65HVD257: Receiver-Dominant Time Out (RXD DTO)
 - SN65HVD257: FAULT Output Pin
 - Thermal Shutdown Protection
- Characterized for -40°C to 125°C Operation

2 Applications

- 1-Mbps Operation in Highly Loaded CAN Networks Down to 10-kbps Networks Using TXD DTO
- Industrial Automation, Control, Sensors, and Drive Systems
- Building, Security, and Climate Control Automation
- Telecom Base Station Status and Control
- SN65HVD257: Functional Safety With Redundant and Multitopology CAN networks
- CAN Bus Standards Such as CANopen, DeviceNet, NMEA2000, ARNIC825, ISO11783, and CANaerospace

3 Description

This CAN transceiver meets the ISO1189-2 High Speed CAN (Controller Area Network) Physical Layer standard. It is designed for data rates in excess of 1 Mbps for CAN in short networks, and enhanced timing margin and higher data rates in long and highly-loaded networks. The device provides many protection features to enhance device and CAN-network robustness. The SN65HVD257 device adds additional features, allowing for easy design of redundant and multitopology networks with fault indication for higher levels of functional safety in the CAN system.

Device Information⁽¹⁾

PART NUMBER	PACKAGE	BODY SIZE (NOM)
SN65HVD255 SN65HVD256 SN65HVD257	SOIC (8)	4.90 mm x 3.91 mm

(1) For all available packages, see the orderable addendum at the end of the data sheet.

Block Diagram

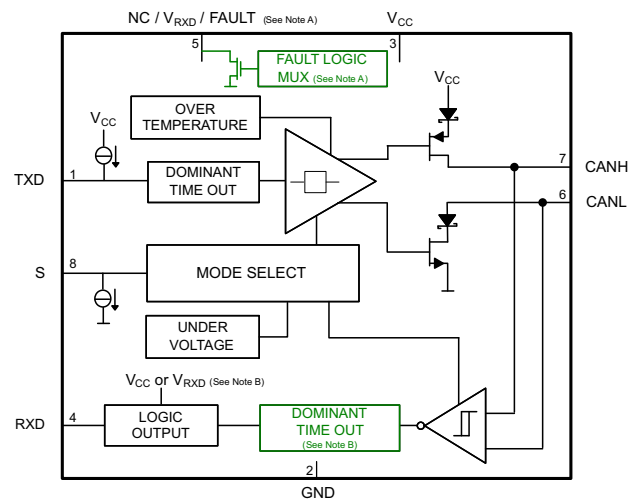

- A. Pin 5 function is device dependent; NC on the SN65HVD255 device, V_{RXD} for RXD output level-shifting device on the SN65HVD256 device, and FAULT Output on the SN65HVD257 device.
- B. RXD logic output is driven to 5-V V_{CC} on 5-V only supply devices (SN65HVD255, SN65HVD257) and driven to V_{RXD} on the output level-shifting device (SN65HVD256).
- C. RXD (Receiver) Dominant State Time Out is a device-dependent option available only on the SN65HVD257 device.



Table of Contents

1 Features	1	9.1 Overview	14
2 Applications	1	9.2 Functional Block Diagram	14
3 Description	1	9.3 Feature Description	14
4 Revision History	2	9.4 Device Functional Modes	19
5 Device Options	4	10 Application and Implementation	22
6 Pin Configuration and Functions	4	10.1 Application Information	22
7 Specifications	5	10.2 Typical Applications	23
7.1 Absolute Maximum Ratings	5	11 Power Supply Recommendations	27
7.2 ESD Ratings	5	12 Layout	27
7.3 Recommended Operating Conditions	6	12.1 Layout Guidelines	27
7.4 Thermal Information	6	12.2 Layout Example	28
7.5 Electrical Characteristics	7	13 Device and Documentation Support	28
7.6 Power Dissipation	9	13.1 Related Links	28
7.7 Switching Characteristics	9	13.2 Trademarks	28
7.8 Typical Characteristics	10	13.3 Electrostatic Discharge Caution	28
8 Parameter Measurement Information	11	13.4 Glossary	28
9 Detailed Description	14	14 Mechanical, Packaging, and Orderable Information	28

4 Revision History

Changes from Revision C (September 2013) to Revision D Page

- Added *Pin Configuration and Functions* section, *ESD Ratings* table, *Switching Characteristics* table, *Typical Characteristics* section, *Feature Description* section, *Device Functional Modes*, *Application and Implementation* section, *Power Supply Recommendations* section, *Layout* section, *Device and Documentation Support* section, and *Mechanical, Packaging, and Orderable Information* section **1**

Changes from Revision B (June 2012) to Revision C Page

- Added [Table 1](#), *Receiver Differential Input Voltage Threshold Test* **12**
- Added [Figure 13](#), *Example Timing Diagram for TXD DTO and FAULT Pin* **17**
- Added *Bus Loading, Length, and Number of Nodes* subsection **22**

Changes from Revision A (June 2012) to Revision B Page

- Added SN65HVD257 status to production in Ordering Information table **4**

Changes from Original (December 2011) to Revision A Page

- Updated the *Features* list **1**
- Updated the *Applications* list **1**
- Added text to the *Description* section **1**
- Changed [Block Diagram](#) - Functional Block Diagram to include HVD257 and Note changes **1**
- Changed the DEVICE OPTIONS table **4**
- Added SN65HVD257 to the D PACKAGE OPTIONS images **4**
- Added SN65HVD257 FAULT pin to the PIN FUNCTIONS table **4**
- Added SN65HVD257 to the Ordering Information table **4**
- Added SN65HVD257 FAULT pin information to the Abs Max table **5**
- Added FAULT pin information to the ROC table **6**

- changed R_{ID} - Differential input resistance value from 3 k Ω to 30 k Ω 8
- Added t_{RXD_DTO} - SN65HVD257 information 10
- Added [Figure 4](#), *RXD Dominant Timeout Test Circuit and Measurement* 11
- Added [Figure 5](#), *FAULT Test and Measurement* 11
- Added RXD Dominant Timeout (SN65HVD257) section..... 15
- Added FAULT pin information 16
- Added footnote for SN65HVD257 function to [Table 5](#) 19
- Added 5-V V_{CC} with FAULT Open-Drain Output Device (SN65HVD257) section..... 21
- Added *Example: Functional Safety Using the SN65HVD257 in a Redundant Physical Layer CAN Network Topology* section 24

5 Device Options

PART NUMBER	I/O SUPPLY for RXD	TXD DTO	RXD DTO	FAULT Output	COMMENT
SN65HVD255	No	Yes	No	No	'251 and '1050 functional upgrade with Turbo CAN fast loop times and TXD DTO protection allowing data rates down to 10 kbps
SN65HVD256	Yes	Yes	No	No	'251 and '1050 functional upgrade with Turbo CAN fast loop times and TXD DTO protection allowing data rates down to 10 kbps. RXD output level shifting through RXD supply input.
SN65HVD257	No	Yes	Yes	Yes	'251 and '1050 functional upgrade with Turbo CAN fast loop times, TXD and RXD DTO protection allowing data rates down to 10 kbps and fault output pin

6 Pin Configuration and Functions

D Package 8-Pin SOIC (Top View)

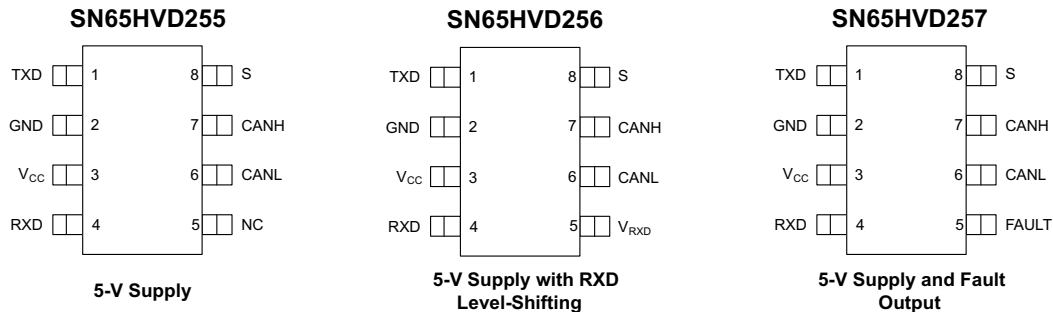

Pin Functions

PIN		TYPE	DESCRIPTION
NAME	NO.		
TXD	1	I	CAN transmit data input (LOW for dominant and HIGH for recessive bus states)
GND	2	GND	Ground connection
V _{CC}	3	Supply	Transceiver 5-V supply voltage
RXD	4	O	CAN receive data output (LOW for dominant and HIGH for recessive bus states)
NC	5	NC	SN65HVD255: No Connect
V _{RXD}		Supply	SN65HVD256: RXD output supply voltage
FAULT		O	SN65HVD257: Open drain FAULT output pin
CANL	6	I/O	Low level CAN bus line
CANH	7	I/O	High level CAN bus line
S	8	I	Mode select: S (silent mode) select pin (active high)

7 Specifications

7.1 Absolute Maximum Ratings⁽¹⁾⁽²⁾

		MIN	MAX	UNIT
V _{CC}	Supply voltage	-0.3	6.1	V
V _{RXD}	RXD Output supply voltage	-0.3	6 and V _{RXD} ≤ V _{CC} + 0.3	V
V _{BUS}	CAN Bus I/O voltage (CANH, CANL)	-27	40	V
V _{Logic_Input}	Logic input pin voltage (TXD, S)	-0.3	6	V
V _{Logic_Output}	Logic output pin voltage (RXD)	-0.3	6	V
V _{Logic_Output}	Logic output pin voltage (RXD)	-0.3	6 and V _I ≤ V _{RXD} + 0.3	V
I _{O(RXD)}	RXD (Receiver) output current		12	mA
I _{O(FAULT)}	FAULT output current		20	mA
T _J	Operating virtual junction temperature (see Power Dissipation)	-40	150	°C
T _A	Ambient temperature (see Power Dissipation)	-40	125	°C

- (1) Stresses beyond those listed under *Absolute Maximum Ratings* may cause permanent damage to the device. These are stress ratings only, which do not imply functional operation of the device at these or any other conditions beyond those indicated under *Recommended Operating Conditions*. Exposure to absolute-maximum-rated conditions for extended periods may affect device reliability.
- (2) All voltage values, except differential I/O bus voltages, are with respect to ground terminal.

7.2 ESD Ratings

		VALUE	UNIT	
V _(ESD)	Human body model (HBM), per ANSI/ESDA/JEDEC JS-001 ⁽¹⁾	All pins	±2500	
		CAN bus pins (CANH, CANL) ⁽²⁾	±12000	
	Charged-device model (CDM), per JEDEC specification JESD22-C101 ⁽³⁾	All pins	±750	
		Machine model	All pins	±250
	IEC 61400-4-2 according to GIFT-ICT CAN EMC test spec ⁽⁴⁾	CAN bus pins (CANH, CANL) to GND	±8000	
		ISO7637 Transients according to GIFT - ICT CAN EMC test spec ⁽⁵⁾	CAN bus pins (CANH, CANL)	Pulse 1
	Pulse 2			+75
	Pulse 3a			-150
Pulse 3b	+100			

- (1) JEDEC document JEP155 states that 500-V HBM allows safe manufacturing with a standard ESD control process.
- (2) Test method based upon JEDEC Standard 22 Test Method A114, CAN bus pins stressed with respect to GND.
- (3) JEDEC document JEP157 states that 250-V CDM allows safe manufacturing with a standard ESD control process.
- (4) IEC 61000-4-2 is a system level ESD test. Results given here are specific to the GIFT-ICT CAN EMC Test specification conditions. Different system level configurations may lead to different results.
- (5) ISO7637 is a system level transient test. Results given here are specific to the GIFT-ICT CAN EMC Test specification conditions. Different system level configurations may lead to different results.

7.3 Recommended Operating Conditions

		MIN	MAX	UNIT
V _{CC}	Supply voltage	4.5	5.5	V
V _{RXD}	RXD supply (SN65HVD256 only)	2.8	5.5	
V _I or V _{IC}	CAN bus terminal voltage (separately or common mode)	-2	7	
V _{ID}	CAN bus differential voltage	-6	6	
V _{IH}	Logic HIGH level input (TXD, S)	2	5.5	
V _{IL}	Logic LOW level input (TXD, S)	0	0.8	
I _{OH(DRVr)}	CAN BUS Driver High level output current	-70		mA
I _{OL(DRVr)}	CAN BUS Driver Low level output current		70	
I _{OH(RXD)}	RXD pin HIGH level output current	-2		
I _{OL(RXD)}	RXD pin LOW level output current		2	
I _{O(FAULT)}	FAULT pin LOW level output current		2	
T _A	Operational free-air temperature (see Power Dissipation)	-40	125	°C

7.4 Thermal Information

THERMAL METRIC ⁽¹⁾		SN65HVD25x	UNIT
		D (SOIC)	
		8 PINS	
R _{θJA}	Junction-to-ambient thermal resistance, High-K thermal resistance ⁽²⁾	107.5	°C/W
R _{θJC(top)}	Junction-to-case (top) thermal resistance	56.7	°C/W
R _{θJB}	Junction-to-board thermal resistance	48.9	°C/W
ψ _{JT}	Junction-to-top characterization parameter	12.1	°C/W
ψ _{JB}	Junction-to-board characterization parameter	48.2	°C/W

- (1) For more information about traditional and new thermal metrics, see the *IC Package Thermal Metrics* application report, [SPRA953](#).
 (2) The junction-to-ambient thermal resistance under natural convection is obtained in a simulation on a JEDEC-standard, High-K board, as specified in JESD51-7, in an environment described in JESD51-2a.

7.5 Electrical Characteristics

Over recommended operating conditions, $T_A = -40^\circ\text{C}$ to 125°C (unless otherwise noted). SN65HVD256 device $V_{\text{RXD}} = V_{\text{CC}}$.

PARAMETER		TEST CONDITIONS	MIN	TYP ⁽¹⁾	MAX	UNIT		
SUPPLY CHARACTERISTICS								
I_{CC}	5-V Supply current	Normal Mode (Driving Dominant)	See Figure 6, TXD = 0 V, $R_L = 50\ \Omega$, $C_L = \text{open}$, $R_{\text{CM}} = \text{open}$, $S = 0\ \text{V}$		60	85	mA	
		Normal Mode (Driving Dominant – bus fault)	See Figure 6, TXD = 0 V, $S = 0\ \text{V}$, CANH = -12 V, $R_L = \text{open}$, $C_L = \text{open}$, $R_{\text{CM}} = \text{open}$		130	180		
		Normal Mode (Driving Dominant)	See Figure 6, TXD = 0 V, $R_L = \text{open}$ (no load), $C_L = \text{open}$, $R_{\text{CM}} = \text{open}$, $S = 0\ \text{V}$		10	20		
		Normal Mode (Recessive)	See Figure 6, TXD = V_{CC} , $R_L = 50\ \Omega$, $C_L = \text{open}$, $R_{\text{CM}} = \text{open}$, $S = 0\ \text{V}$		10	20		
		Silent Mode	See Figure 6, TXD = V_{CC} , $R_L = 50\ \Omega$, $C_L = \text{open}$, $R_{\text{CM}} = \text{open}$, $S = V_{\text{CC}}$		2.5	5		
I_{RXD}	RXD Supply current (SN65HVD256 only)	All modes	RXD Floating, TXD = 0 V		500	μA		
UV_{VCC}	Undervoltage detection on V_{CC} for protected mode		3.5		4.45	V		
$V_{\text{HYS}(UV_{\text{VCC}})}$	Hysteresis voltage on UV_{VCC}			200		mV		
UV_{RXD}	Undervoltage detection on V_{RXD} for protected mode (SN65HVD256 only)		1.3		2.75	V		
$V_{\text{HYS}(UV_{\text{RXD}})}$	Hysteresis voltage on UV_{RXD} (SN65HVD256 only)			80		mV		
S PIN (MODE SELECT INPUT)								
V_{IH}	HIGH-level input voltage		2			V		
V_{IL}	LOW-level input voltage				0.8	V		
I_{IH}	HIGH-level input leakage current		$S = V_{\text{CC}} = 5.5\ \text{V}$		7	100	μA	
I_{IL}	Low-level input leakage current		$S = 0\ \text{V}$, $V_{\text{CC}} = 5.5\ \text{V}$		-1	0	1	μA
$I_{\text{LKG(OFF)}}$	Unpowered leakage current		$S = 5.5\ \text{V}$, $V_{\text{CC}} = 0\ \text{V}$, $V_{\text{RXD}} = 0\ \text{V}$		7	35	100	μA
TXD PIN (CAN TRANSMIT DATA INPUT)								
V_{IH}	HIGH level input voltage		2			V		
V_{IL}	LOW level input voltage				0.8	V		
I_{IH}	HIGH level input leakage current		TXD = $V_{\text{CC}} = 5.5\ \text{V}$		-2.5	0	1	μA
I_{IL}	Low level input leakage current		TXD = 0 V, $V_{\text{CC}} = 5.5\ \text{V}$		-100	-25	-7	μA
$I_{\text{LKG(OFF)}}$	Unpowered leakage current		TXD = 5.5 V, $V_{\text{CC}} = 0\ \text{V}$, $V_{\text{RXD}} = 0\ \text{V}$		-1	0	1	μA
C_1	Input Capacitance			3.5		pF		
RXD PIN (CAN RECEIVE DATA OUTPUT)								
V_{OH}	HIGH level output voltage		See Figure 7, $I_O = -2\ \text{mA}$. For devices with V_{RXD} supply $V_{\text{OH}} = 0.8 \times V_{\text{RXD}}$		$0.8 \times V_{\text{CC}}$		V	
V_{OL}	LOW level output voltage		See Figure 7, $I_O = 2\ \text{mA}$			0.4	V	
$I_{\text{LKG(OFF)}}$	Unpowered leakage current		RXD = 5.5 V, $V_{\text{CC}} = 0\ \text{V}$, $V_{\text{RXD}} = 0\ \text{V}$		-1	0	1	μA

(1) All typical values are at 25°C and supply voltages of $V_{\text{CC}} = 5\ \text{V}$ and $V_{\text{RXD}} = 5\ \text{V}$, $R_L = 60\ \Omega$.

Electrical Characteristics (continued)

 Over recommended operating conditions, $T_A = -40^\circ\text{C}$ to 125°C (unless otherwise noted). SN65HVD256 device $V_{RXD} = V_{CC}$.

PARAMETER		TEST CONDITIONS	MIN	TYP ⁽¹⁾	MAX	UNIT	
DRIVER ELECTRICAL CHARACTERISTICS							
$V_{O(D)}$	Bus output voltage (dominant)	CANH	See Figure 15 and Figure 6, TXD = 0 V, S = 0 V, $R_L = 60\ \Omega$, $C_L = \text{open}$, $R_{CM} = \text{open}$		2.75	4.5	V
		CANL			0.5	2.25	
$V_{O(R)}$	Bus output voltage (recessive)	See Figure 15 and Figure 6, TXD = V_{CC} , $V_{RXD} = V_{CC}$, S = V_{CC} or 0 V ⁽²⁾ , $R_L = \text{open}$ (no load), $R_{CM} = \text{open}$	2	$0.5 \times V_{CC}$	3	V	
$V_{OD(D)}$	Differential output voltage (dominant)	See Figure 15 and Figure 6, TXD = 0 V, S = 0 V, $45\ \Omega \leq R_L \leq 65\ \Omega$, $C_L = \text{open}$, $R_{CM} = 330\ \Omega$, $-2\ \text{V} \leq V_{CM} \leq 7\ \text{V}$, $4.75\ \text{V} \leq V_{CC} \leq 5.25\ \text{V}$	1.5		3	V	
		See Figure 15 and Figure 6, TXD = 0 V, S = 0 V, $45\ \Omega \leq R_L \leq 65\ \Omega$, $C_L = \text{open}$, $R_{CM} = 330\ \Omega$, $-2\ \text{V} \leq V_{CM} \leq 7\ \text{V}$, $4.5\ \text{V} \leq V_{CC} \leq 5.5\ \text{V}$	1.25		3.2		
$V_{OD(R)}$	Differential output voltage (recessive)	See Figure 15 and Figure 6, TXD = V_{CC} , S = 0 V, $R_L = 60\ \Omega$, $C_L = \text{open}$, $R_{CM} = \text{open}$	-0.12		0.012	V	
		See Figure 15 and Figure 6, TXD = V_{CC} , S = 0 V, $R_L = \text{open}$ (no load), $C_L = \text{open}$, $R_{CM} = \text{open}$, $-40^\circ\text{C} \leq T_A \leq 85^\circ\text{C}$	-0.100		0.050		
V_{SYM}	Output symmetry (dominant or recessive) ($V_{CC} - V_{O(CANH)} - V_{O(CANL)}$)	See Figure 15 and Figure 6, S at 0 V, $R_L = 60\ \Omega$, $C_L = \text{open}$, $R_{CM} = \text{open}$	-0.4		0.4	V	
$I_{OS(SS_DOM)}$	Short circuit steady-state output current, Dominant	See Figure 15 and Figure 11, $V_{CANH} = 0\ \text{V}$, CANL = open, TXD = 0 V	-160			mA	
		See Figure 15 and Figure 11, $V_{CANL} = 32\ \text{V}$, CANH = open, TXD = 0 V			160		
$I_{OS(SS_REC)}$	Short circuit steady-state output current, Recessive	See Figure 15 and Figure 11, $-20\ \text{V} \leq V_{BUS} \leq 32\ \text{V}$, Where $V_{BUS} = \text{CANH} = \text{CANL}$, TXD = V_{CC} , Normal and Silent Modes	-8		8	mA	
C_O	Output capacitance	See Input capacitance to ground (C_I) in the following Receiver Electrical Characteristics section of this table					
RECEIVER ELECTRICAL CHARACTERISTICS							
V_{IT+}	Positive-going input threshold voltage, normal mode	See Figure 7, Table 5 and Table 1			900	mV	
V_{IT-}	Negative-going input threshold voltage, normal mode		500			mV	
V_{HYS}	Hysteresis voltage ($V_{IT+} - V_{IT-}$)			125		mV	
$I_{IOFF(LKG)}$	Power-off (unpowered) bus input leakage current	$V_{CANH} = V_{CANL} = 5\ \text{V}$, $V_{CC} = 0\ \text{V}$, $V_{RXD} = 0\ \text{V}$			5.5	μA	
C_I	Input capacitance to ground (CANH or CANL)	TXD = V_{CC} , $V_{RXD} = V_{CC}$, $V_I = 0.4 \sin(4E6 \pi t) + 2.5\ \text{V}$		25		pF	
C_{ID}	Differential input capacitance	TXD = V_{CC} , $V_{RXD} = V_{CC}$, $V_I = 0.4 \sin(4E6 \pi t)$		10		pF	
R_{ID}	Differential input resistance	TXD = $V_{CC} = V_{RXD} = 5\ \text{V}$, S = 0 V	30		80	k Ω	
R_{IN}	Input resistance (CANH or CANL)		15		40	k Ω	
$R_{IN(M)}$	Input resistance matching: [1 - $R_{IN(CANH)} / R_{IN(CANL)}$] \times 100%	$V_{(CANH)} = V_{(CANL)}$, $-40^\circ\text{C} \leq T_A \leq 85^\circ\text{C}$	-3%		3%		

(2) For the bus output voltage (recessive) will be the same if the device is in normal mode with S pin LOW or if the device is in silent mode with the S pin HIGH.

Electrical Characteristics (continued)

Over recommended operating conditions, $T_A = -40^{\circ}\text{C}$ to 125°C (unless otherwise noted), SN65HVD256 device $V_{\text{RXD}} = V_{\text{CC}}$.

PARAMETER		TEST CONDITIONS	MIN	TYP ⁽¹⁾	MAX	UNIT
FAULT PIN (FAULT OUTPUT), SN65HVD257 ONLY						
I_{CH}	Output current high level	FAULT = V_{CC} , see Figure 5	-10		10	μA
I_{CL}	Output current low level	FAULT = 0.4 V, see Figure 5	5	12		mA

7.6 Power Dissipation

THERMAL METRIC		TEST CONDITIONS	TYP	UNIT
P_{D}	Average power dissipation	$V_{\text{CC}} = 5\text{ V}$, $V_{\text{RXD}} = 5\text{ V}$, $T_{\text{J}} = 27^{\circ}\text{C}$, $R_{\text{L}} = 60\ \Omega$, S at 0 V, Input to TXD at 250 kHz, 25% duty cycle square wave, $C_{\text{L,RXD}} = 15\text{ pF}$. Typical CAN operating conditions at 500 kbps with 25% transmission (dominant) rate.	115	mW
		$V_{\text{CC}} = 5.5\text{ V}$, $V_{\text{RXD}} = 5.5\text{ V}$, $T_{\text{J}} = 150^{\circ}\text{C}$, $R_{\text{L}} = 50\ \Omega$, S at 0 V, Input to TXD at 500 kHz, 50% duty cycle square wave, $C_{\text{L,RXD}} = 15\text{ pF}$. Typical high load CAN operating conditions at 1 Mbps with 50% transmission (dominant) rate and loaded network.	268	
Thermal shutdown temperature			170	$^{\circ}\text{C}$
Thermal shutdown hysteresis			5	$^{\circ}\text{C}$

7.7 Switching Characteristics

over operating free-air temperature range (unless otherwise noted)

PARAMETER		TEST CONDITIONS	MIN	TYP	MAX	UNIT
DEVICE SWITCHING CHARACTERISTICS						
$t_{\text{PROP(LOOP1)}}$	Total loop delay, driver input (TXD) to receiver output (RXD), recessive to dominant	See Figure 9, S = 0 V, $R_{\text{L}} = 60\ \Omega$, $C_{\text{L}} = 100\text{ pF}$, $C_{\text{L,RXD}} = 15\text{ pF}$			150	ns
$t_{\text{PROP(LOOP2)}}$	Total loop delay, driver input (TXD) to receiver output (RXD), dominant to recessive				150	
t_{MODE}	Mode change time, from Normal to Silent or from Silent to Normal	See Figure 8			20	μS
DRIVER SWITCHING CHARACTERISTICS						
t_{pHR}	Propagation delay time, HIGH TXD to Driver Recessive	See Figure 6, S = 0 V, $R_{\text{L}} = 60\ \Omega$, $C_{\text{L}} = 100\text{ pF}$, $R_{\text{CM}} = \text{open}$		50	70	ns
t_{pLD}	Propagation delay time, LOW TXD to Driver Dominant			40	70	
$t_{\text{sk(p)}}$	Pulse skew ($ t_{\text{pHR}} - t_{\text{pLD}} $)			10		
t_{R}	Differential output signal rise time			10	30	
t_{F}	Differential output signal fall time			17	30	
$t_{\text{R(10k)}}$	Differential output signal rise time, $R_{\text{L}} = 10\text{ k}\Omega$	See Figure 6, S = 0 V, $R_{\text{L}} = 10\text{ k}\Omega$, $C_{\text{L}} = 10\text{ pF}$, $R_{\text{CM}} = \text{open}$			35	ns
$t_{\text{F(10k)}}$	Differential output signal fall time, $R_{\text{L}} = 10\text{ k}\Omega$				100	
$t_{\text{TXD_DTO}}$	Dominant timeout ⁽¹⁾	See Figure 10, $R_{\text{L}} = 60\ \Omega$, $C_{\text{L}} = \text{open}$	1175		3700	μs

- (1) The TXD dominant timeout ($t_{\text{TXD_DTO}}$) disables the driver of the transceiver when the TXD has been dominant longer than $t_{\text{TXD_DTO}}$, which releases the bus lines to recessive, thus preventing a local failure from locking the bus dominant. The driver may only transmit dominant again after TXD has been returned HIGH (recessive). While this protects the bus from local faults locking the bus dominant, it limits the minimum data rate possible. The CAN protocol allows a maximum of eleven successive dominant bits (on TXD) for the worst case, where five successive dominant bits are followed immediately by an error frame. This, along with the $t_{\text{TXD_DTO}}$ minimum, limits the minimum bit rate. The minimum bit rate may be calculated by: Minimum Bit Rate = $11 / t_{\text{TXD_DTO}} = 11\text{ bits} / 1175\ \mu\text{s} = 9.4\text{ kbps}$.

Switching Characteristics (continued)

over operating free-air temperature range (unless otherwise noted)

PARAMETER		TEST CONDITIONS	MIN	TYP	MAX	UNIT
RECEIVER SWITCHING CHARACTERISTICS						
t_{pRH}	Propagation delay time, recessive input to high output	See Figure 7, $C_{L_RXD} = 15$ pF		70	90	ns
t_{pDL}	Propagation delay time, dominant input to low output			70	90	ns
t_R	Output signal rise time			4	20	ns
t_F	Output signal fall time			4	20	ns
$t_{RXD_DTO}^{(2)}$	Receiver dominant time out (SN65HVD257 only) See Figure 4, $C_{L_RXD} = 15$ pF		1380		4200	μ s

- (2) The RXD timeout (t_{RXD_DTO}) disables the RXD output in the case that the bus has been dominant longer than t_{RXD_DTO} , which releases RXD pin to the recessive state (high), thus preventing a dominant bus failure from permanently keeping the RXD pin low. The RXD pin will automatically resume normal operation once the bus has been returned to a recessive state. While this protects the protocol controller from a permanent dominant state, it limits the minimum data rate possible. The CAN protocol allows a maximum of eleven successive dominant bits (on RXD) for the worst case, where five successive dominant bits are followed immediately by an error frame. This, along with the t_{RXD_DTO} minimum, limits the minimum bit rate. The minimum bit rate may be calculated by: Minimum Bit Rate = $11 / t_{RXD_DTO} = 11 \text{ bits} / 1380 \mu\text{s} = 8 \text{ kbps}$.

7.8 Typical Characteristics

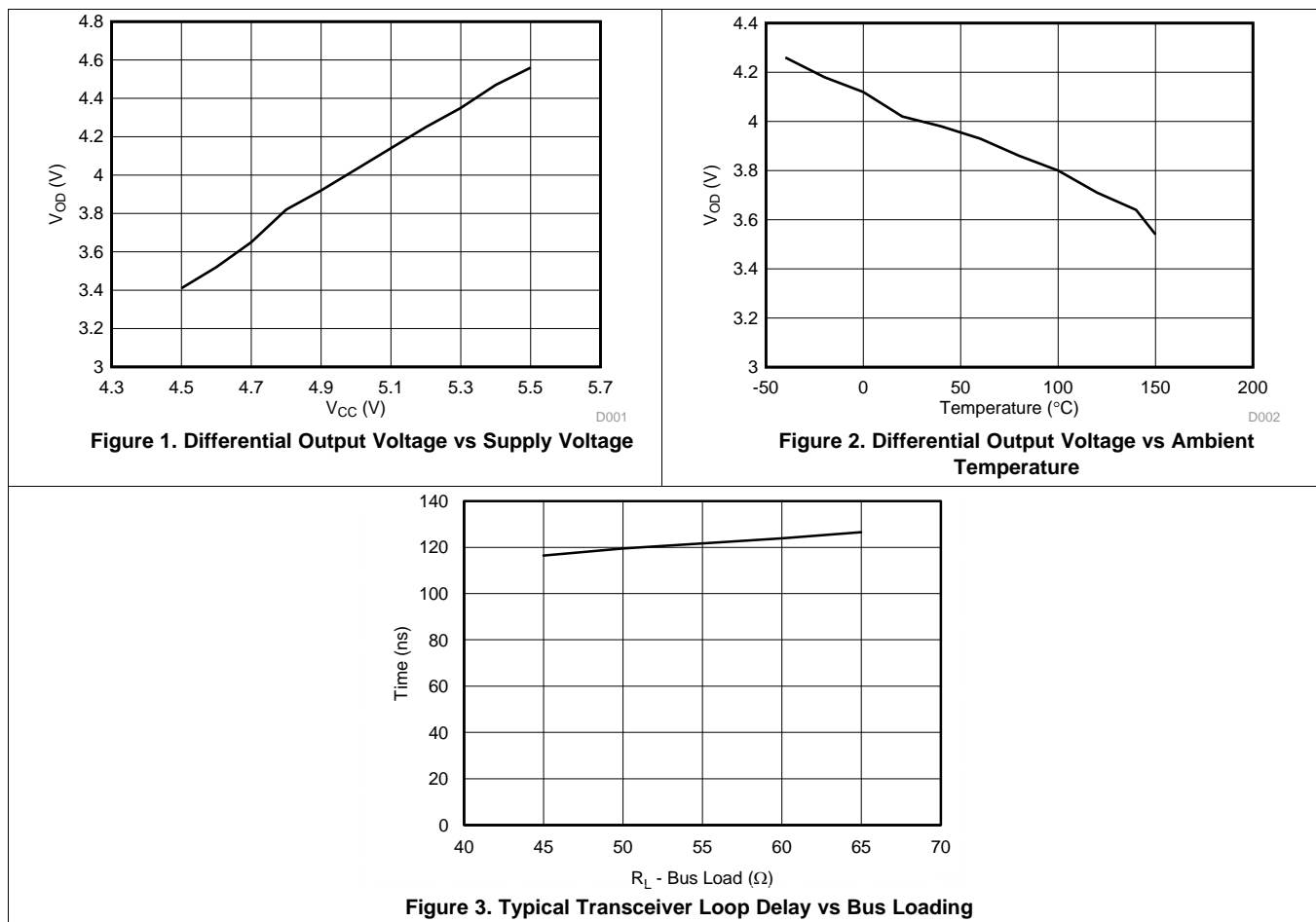

8 Parameter Measurement Information

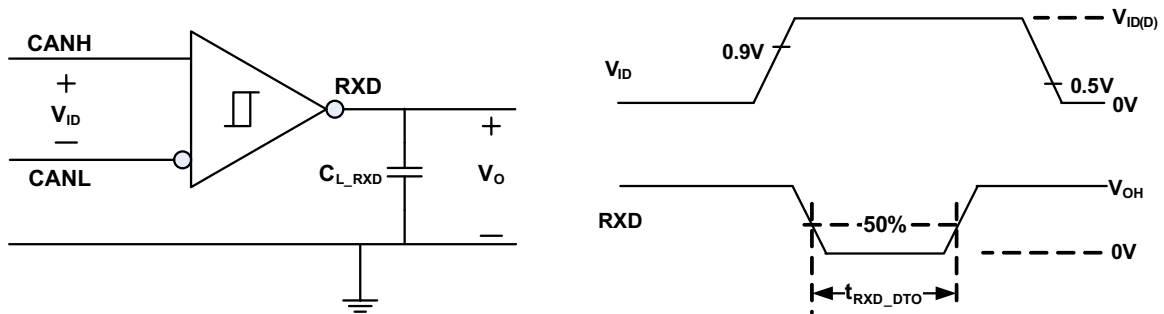

Figure 4. RXD Dominant Timeout Test Circuit and Measurement

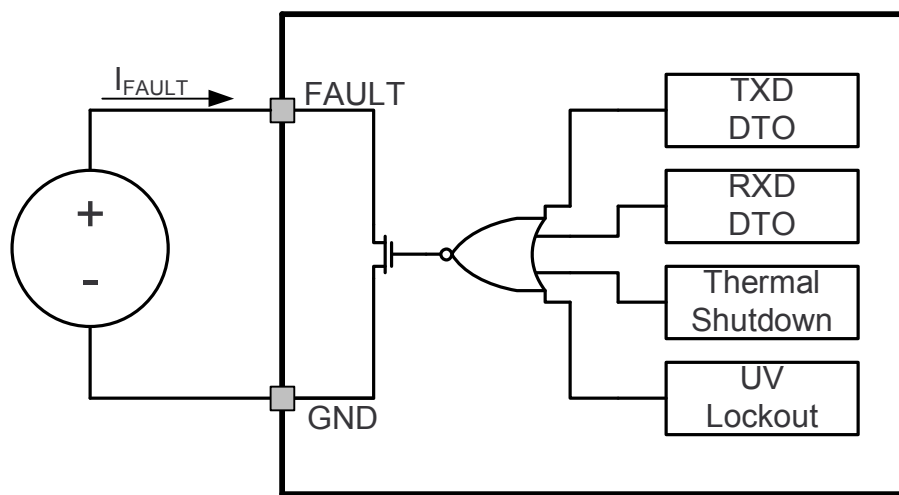

Figure 5. FAULT Test and Measurement

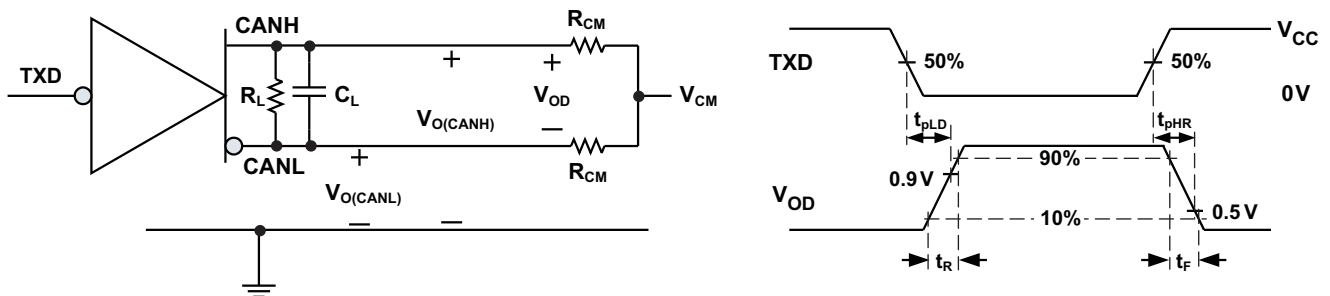

Figure 6. Driver Test Circuit and Measurement

Parameter Measurement Information (continued)

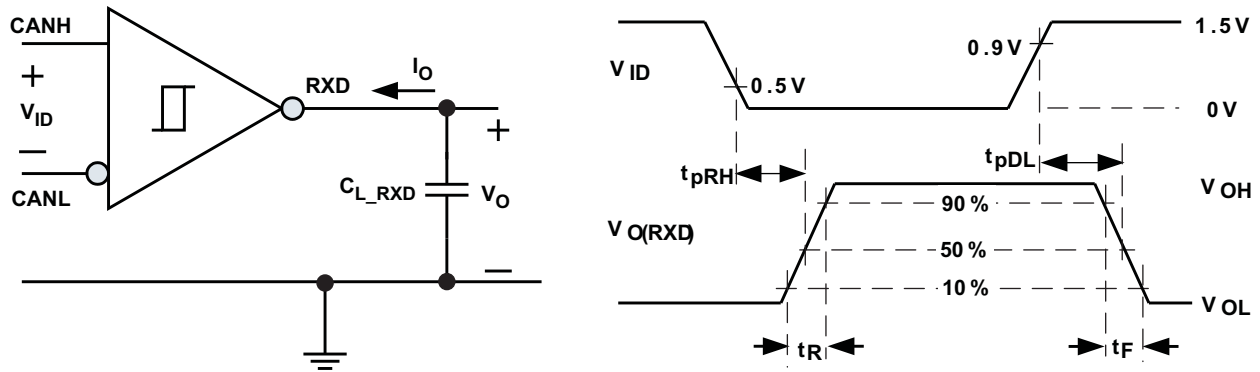

Figure 7. Receiver Test Circuit and Measurement

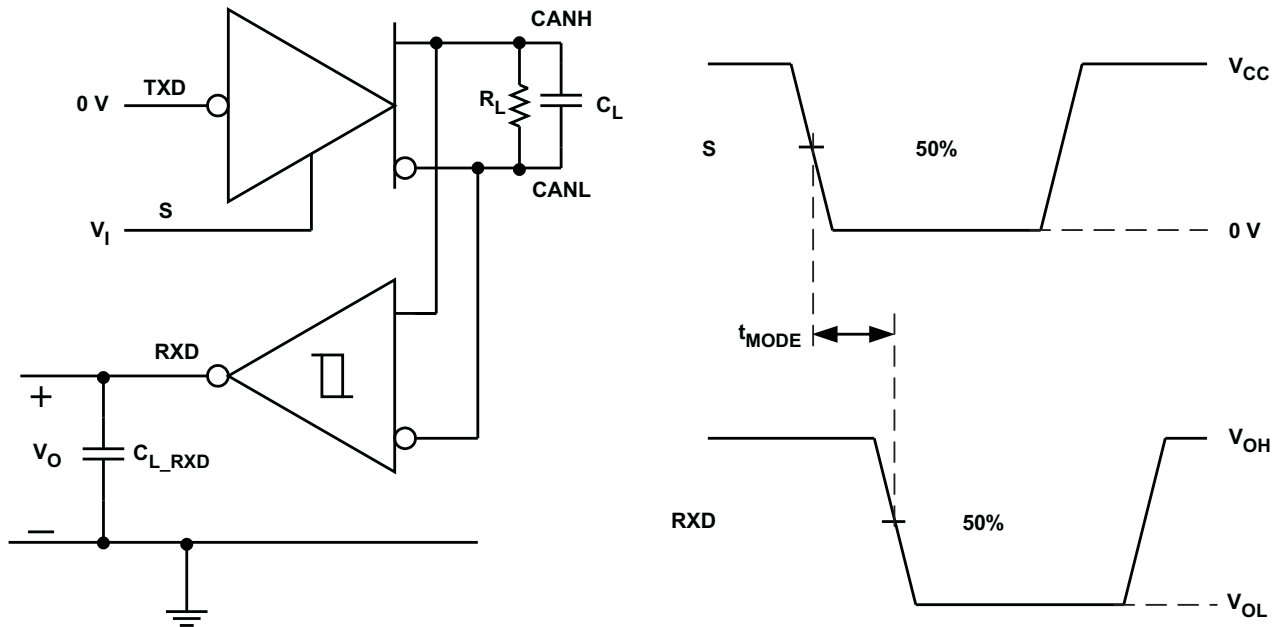

Figure 8. t_{MODE} Test Circuit and Measurement

Table 1. Receiver Differential Input Voltage Threshold Test

INPUT			OUTPUT	
V_{CANH}	V_{CANL}	$ V_{ID} $	R_{XD}	
-1.1 V	-2.0 V	900 mV	L	V_{OL}
7.0 V	6.1 V	900 mV	L	
-1.5 V	-2.0 V	500 mV	H	V_{OH}
7.0 V	6.5 V	500 mV	H	
Open	Open	X	H	

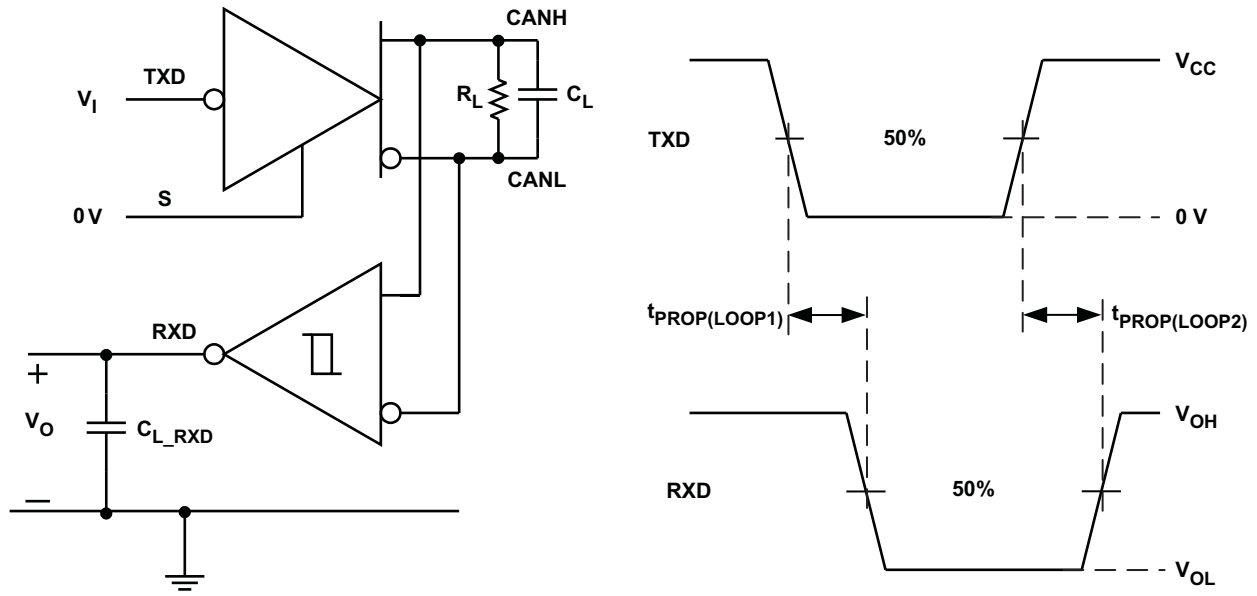

Figure 9. $T_{PROP(LOOP)}$ Test Circuit and Measurement

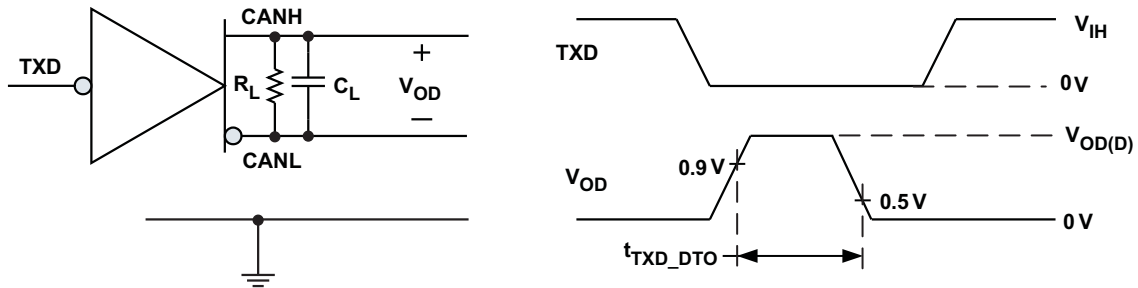

Figure 10. TXD Dominant Timeout Test Circuit and Measurement

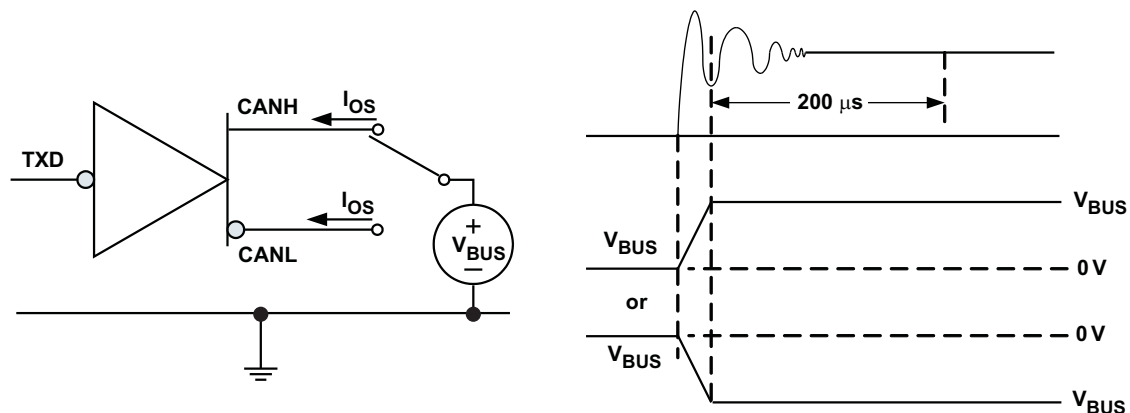

Figure 11. Driver Short Circuit Current Test and Measurement

9 Detailed Description

9.1 Overview

The SN65HVD25x family of bus transceiver devices are compatible with the ISO 11898-2 High Speed CAN (Controller Area Network) physical layer standard. The SN65HVD25x devices are designed to interface between the differential bus lines and the CAN protocol controller at data rates up to 1 Mbps (megabits per second).

9.2 Functional Block Diagram

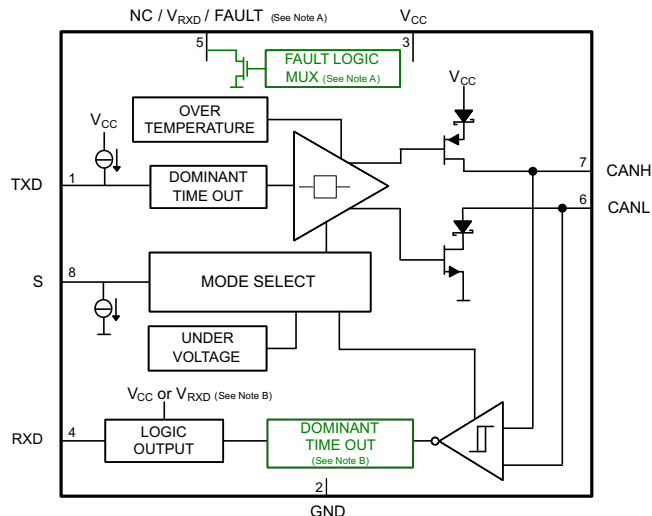

- Pin 5 function is device dependent; NC on SN65HVD255, V_{RXD} for RXD output level-shifting device on the SN65HVD256 device, and FAULT Output on the SN65HVD257 device.
- RXD logic output is driven to 5-V V_{CC} on 5-V only supply devices (SN65HVD255, SN65HVD257) and driven to V_{RXD} on output level-shifting device (SN65HVD256).
- RXD (Receiver) Dominant State Time Out is a device dependent option available only on the SN65HVD257 device.

9.3 Feature Description

9.3.1 TXD Dominant Timeout (DTO)

During normal mode (the only mode where the CAN driver is active), the TXD DTO circuit prevents the transceiver from blocking network communication in the event of a hardware or software failure where TXD is held dominant longer than the timeout period t_{TXD_DTO} . The DTO circuit timer starts on a falling edge on TXD. The DTO circuit disables the CAN bus driver if no rising edge is seen before the timeout period expires, which frees the bus for communication between other nodes on the network. The CAN driver is reactivated when a recessive signal is seen on TXD pin, thus clearing the TXD DTO condition. The receiver and RXD pin still reflect the CAN bus, and the bus pins are biased to recessive level during a TXD dominant timeout.

NOTE

The minimum dominant TXD time allowed by the TXD DTO circuit limits the minimum possible transmitted data rate of the device. The CAN protocol allows a maximum of eleven successive dominant bits (on TXD) for the worst case, where five successive dominant bits are followed immediately by an error frame. This, along with the t_{TXD_DTO} minimum, limits the minimum data rate. Calculate the minimum transmitted data rate by:
 Minimum Data Rate = $11 / t_{TXD_DTO}$.

Feature Description (continued)

9.3.2 RXD Dominant Timeout (SN65HVD257)

The SN65HVD257 device has a RXD dominant timeout (RXD DTO) circuit that prevents a bus stuck dominant fault from permanently driving the RXD output dominant (low) when the bus is held dominant longer than the timeout period t_{RXD_DTO} . The RXD DTO timer starts on a falling edge on RXD (bus going dominant). If no rising edge (bus returning recessive) is seen before the timeout constant of the circuit expires (t_{RXD_DTO}), the RXD pin returns high (recessive). The RXD output is reactivated to mirror the bus receiver output when a recessive signal is seen on the bus, clearing the RXD dominant timeout. The CAN bus pins are biased to the recessive level during a RXD DTO.

NOTE

The minimum dominant RXD time allowed by the RXD DTO limits the minimum possible received data rate of the device. The CAN protocol allows a maximum of eleven successive dominant bits for the worst case transmission, where five successive dominant bits are followed immediately by an error frame. This, along with the t_{RXD_DTO} minimum, limits the minimum data rate. The minimum received data rate may be calculated by:
Minimum Data Rate = $11 / t_{RXD_DTO}$.

9.3.3 Thermal Shutdown

If the junction temperature of the device exceeds the thermal shut down threshold, the device turns off the CAN driver circuits thus blocking the TXD to bus transmission path. The shutdown condition is cleared when the junction temperature drops below the thermal shutdown temperature of the device.

NOTE

During thermal shutdown the CAN bus drivers turn off; thus, no transmission is possible from TXD to the bus. The CAN bus pins are biased to recessive level during a thermal shutdown, and the receiver to RXD path remains operational.

9.3.4 Undervoltage Lockout

The supply pins have undervoltage detection that places the device in protected mode, which protects the bus during an undervoltage event on either the V_{CC} or V_{RXD} supply pins.

Table 2. Undervoltage Lockout 5-V Only Devices (SN65HVD255 and SN65HVD257)

V_{CC}	DEVICE STATE	BUS OUTPUT	RXD
GOOD	Normal	Per Device State and TXD	Mirrors Bus
BAD	Protected	High Impedance	High Impedance (3-state)

Table 3. Undervoltage Lockout 5 V and V_{RXD} Device (SN65HVD256)

V_{CC}	V_{RXD}	DEVICE STATE	BUS OUTPUT	RXD
GOOD	GOOD	Normal	Per Device State and TXD	Mirrors Bus
BAD	GOOD	Protected	High Impedance	High (Recessive)
GOOD	BAD	Protected	Recessive	High Impedance (3-state)
BAD	BAD	Protected	High Impedance	High Impedance (3-state)

NOTE

After an undervoltage condition is cleared and the supplies have returned to valid levels, the device typically resumes normal operation in 300 μ s.

9.3.5 FAULT Pin (SN65HVD257)

If one or more of the faults (TXD dominant timeout, RXD dominant timeout, thermal shutdown or undervoltage lockout) occurs, the FAULT pin (open-drain) turns off, resulting in a high level when externally pulled up to V_{CC} or I/O supply.

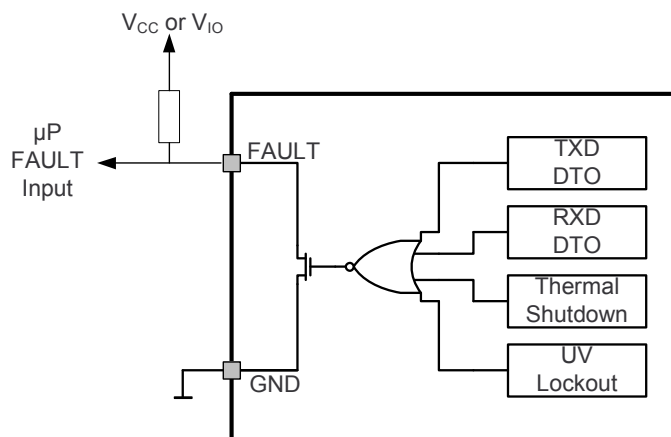
Figure 12. FAULT Pin Function Diagram and Application

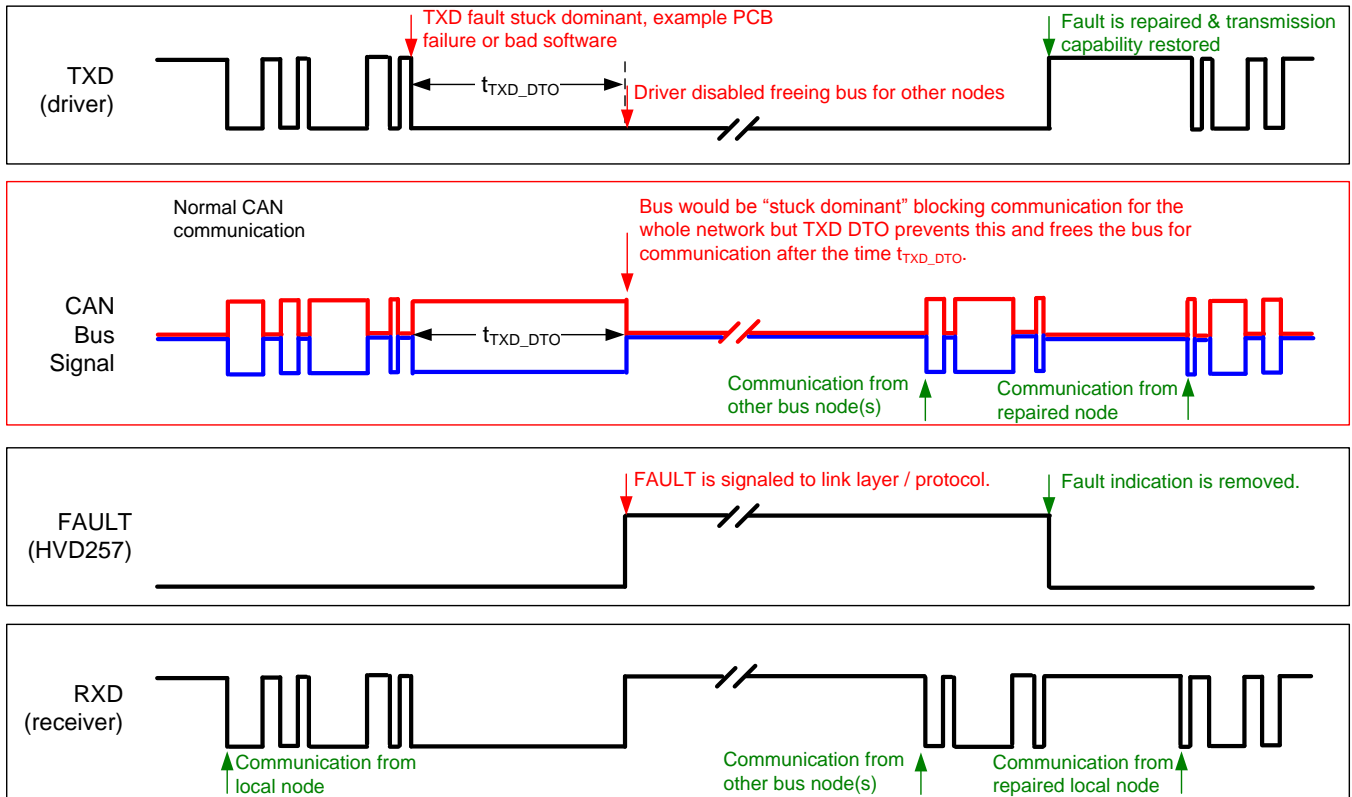

Figure 13. Example Timing Diagram for TXD DTO and FAULT Pin

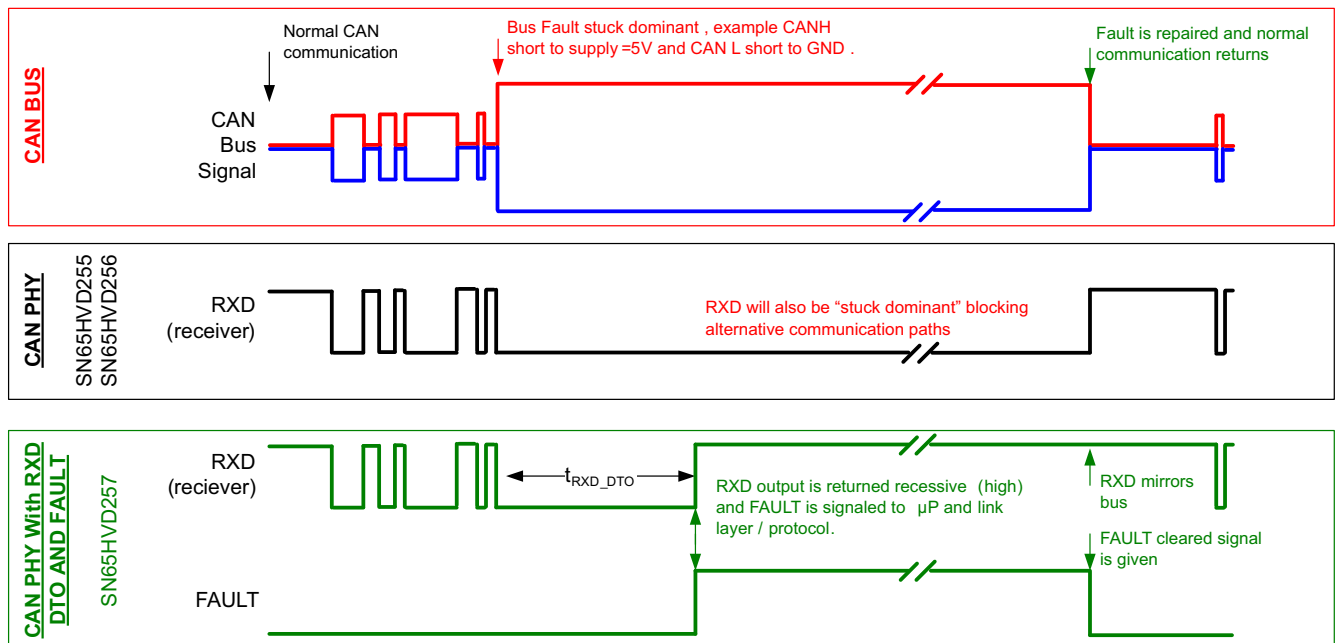

Figure 14. Example Timing Diagram for Devices With and Without RXD DTO and FAULT Pin

9.3.6 Unpowered Device

The SN65HVD25x device is designed to be an *ideal passive* or *no load* to the CAN bus if it is unpowered. The bus pins (CANH, CANL) have extremely low leakage currents when the device is unpowered, so they will not load down the bus. This is critical if some nodes of the network will be unpowered while the rest of the network remains in operation. The logic pins also have extremely low leakage currents when the device is unpowered to avoid loading down other circuits that may remain powered.

9.3.7 Floating Pins

The device has internal pullups and pulldowns on critical pins to place the device into known states if the pins float. The TXD pin is pulled up to V_{CC} to force a recessive input level if the pin floats. The S pin is pulled down to GND to force the device into normal mode if the pin floats.

9.3.8 CAN Bus Short-Circuit Current Limiting

The SN65HVD25x device has several protection features that limit the short circuit current when a CAN bus line is shorted. These features include driver current limiting (dominant and recessive). The device has TXD dominant state time out to prevent permanent higher short circuit current of the dominant state during a system fault. During CAN communication, the bus switches between dominant and recessive states with the data and control fields bits; thus the short circuit current may be viewed either as the instantaneous current during each bus state or as a DC average current. For system current (power supply) and power considerations in the termination resistors and common-mode choke ratings, use the average short circuit current. Determine the ratio of dominant and recessive bits by the data in the CAN frame plus the following factors of the protocol and PHY that force either recessive or dominant at the following times:

- Control fields with set bits
- Bit stuffing
- Interframe space
- TXD dominant time out (fault case limiting)

These factors ensure a minimum recessive amount of time on the bus even if the data field contains a high percentage of dominant bits.

The short circuit current of the bus depends on the ratio of recessive to dominant bits and their respective short circuit currents. The average short circuit current may be calculated with [Equation 1](#).

$$I_{OS(AVG)} = \%Transmit \times [(\%REC_Bits \times I_{OS(SS_REC)}) + (\%DOM_Bits \times I_{OS(SS_DOM)})] + [\%Receive \times I_{OS(SS_REC)}] \quad (1)$$

where:

$I_{OS(AVG)}$ is the average short circuit current

$\%Transmit$ is the percentage the node is transmitting CAN messages

$\%Receive$ is the percentage the node is receiving CAN messages

$\%REC_Bits$ is the percentage of recessive bits in the transmitted CAN messages

$\%DOM_Bits$ is the percentage of dominant bits in the transmitted CAN messages

$I_{OS(SS_REC)}$ is the recessive steady state short circuit current

$I_{OS(SS_DOM)}$ is the dominant steady state short circuit current

NOTE

Consider the short circuit current and possible fault cases of the network when sizing the power ratings of the termination resistance and other network components.

9.4 Device Functional Modes

Table 4. Driver Function Table

DEVICE	INPUTS		OUTPUTS		DRIVEN BUS STATE
	S ⁽¹⁾⁽²⁾	TXD ⁽¹⁾⁽³⁾	CANH ⁽¹⁾	CANL ⁽¹⁾	
All Devices	L or Open	L	H	L	Dominant
		H or Open	Z	Z	Recessive
	H	X	Z	Z	Recessive

(1) H = high level, L = low level, X = irrelevant, Z = common mode (recessive) bias to $V_{CC} / 2$. See [Figure 15](#) and [Figure 16](#) for bus state and common mode bias information.

(2) Devices have an internal pulldown to GND on S pin. If S pin is open the pin will be pulled low and the device will be in normal mode.

(3) Devices have an internal pullup to V_{CC} on TXD pin. If the TXD pin is open the pin will be pulled high and the transmitter will remain in recessive (nondriven) state.

Table 5. Receiver Function Table

DEVICE MODE	CAN DIFFERENTIAL INPUTS $V_{ID} = V_{CANH} - V_{CANL}$	BUS STATE	RXD PIN ⁽¹⁾
Normal or Silent	$V_{ID} \geq 0.9 V$	Dominant	L ⁽²⁾
	$0.5 V < V_{ID} < 0.9 V$?	?
	$V_{ID} \leq 0.5 V$	Recessive	H
	Open ($V_{ID} \approx 0 V$)	Open	H

(1) H = high level, L = low level, ? = indeterminate.

(2) RXD output remains dominant (low) as long as the bus is dominant. On the SN65HVD257 device with RXD dominant timeout, when the bus has been dominant longer than the dominant timeout, t_{RXD_DTO} , the RXD pin will return recessive (high). See [RXD Dominant Timeout \(SN65HVD257\)](#) for a description of behavior during receiving a bus stuck dominant condition.

9.4.1 Operating Modes

The device has two main operating modes: normal mode and silent mode. Operating mode selection is made via the S input pin.

Table 6. Operating Modes

S Pin	MODE	DRIVER	RECEIVER	RXD PIN
LOW	Normal Mode	Enabled (ON)	Enabled (ON)	Mirrors Bus State ⁽¹⁾
HIGH	Silent Mode	Disabled (OFF)	Enabled (ON)	Mirrors Bus State

(1) Mirrors bus state: low if CAN bus is dominant, high if CAN bus is recessive.

9.4.2 Can Bus States

The CAN bus has two states during powered operation of the device: *dominant* and *recessive*. A dominant bus state is when the bus is driven differentially, corresponding to a logic low on the TXD and RXD pin. A recessive bus state is when the bus is biased to $V_{CC} / 2$ via the high-resistance internal input resistors R_{IN} of the receiver, corresponding to a logic high on the TXD and RXD pins. See [Figure 15](#) and [Figure 16](#).

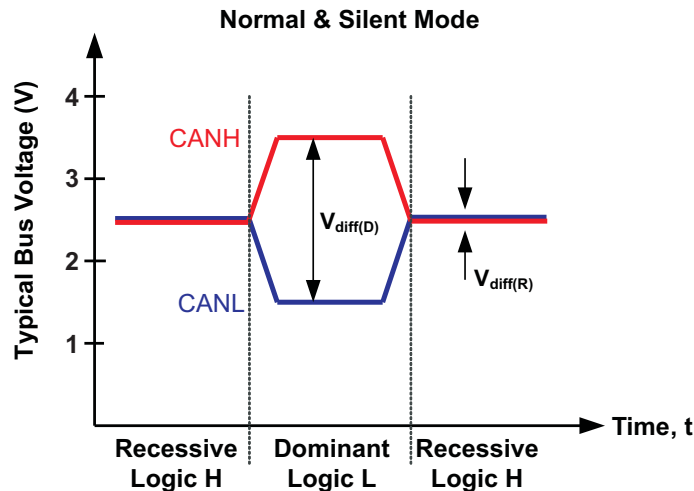

Figure 15. Bus States (Physical Bit Representation)

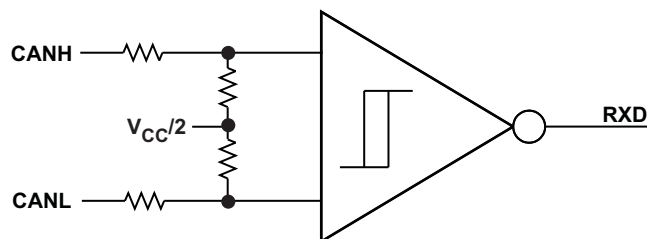

Figure 16. Simplified Recessive Common Mode Bias and Receiver

9.4.3 Normal Mode

Select the normal mode of device operation by setting S low. The CAN driver and receiver are fully operational and CAN communication is bidirectional. The driver is translating a digital input on TXD to a differential output on CANH and CANL. The receiver is translating the differential signal from CANH and CANL to a digital output on RXD.

9.4.4 Silent Mode

Activate silent mode (receive only) by setting S high. The CAN driver is turned off while the receiver remains active and RXD outputs the received bus state.

NOTE

Silent mode may be used to implement babbling idiot protection, to ensure that the driver does not disrupt the network during a local fault. Silent mode may also be used in redundant systems to select or de-select the redundant transceiver (driver) when needed.

9.4.5 Digital Inputs and Outputs

9.4.5.1 5-V V_{CC} Only Devices (SN65HVD255 and SN65HVD257)

The 5-V V_{CC} device is supplied by a single 5-V rail. The digital inputs are 5-V and 3.3-V compatible. The SN65HVD255 and SN65HVD257 devices have a 5-V (V_{CC}) level RXD output. TXD is internally pulled up to V_{CC} and S is internally pulled down to GND.

NOTE

TXD is internally pulled up to V_{CC} and the S pin is internally pulled down to GND. However, the internal bias may only put the device into a known state if the pins float. The internal bias may be inadequate for system-level biasing. TXD pullup strength and CAN bit timing require special consideration when the SN65HVD25x devices are used with an open-drain TXD output on the CAN controller. An adequate external pullup resistor must be used to ensure that the CAN controller output of the μP maintains adequate bit timing input to the SN65HVD25x devices.

9.4.5.2 5-V V_{CC} With V_{RXD} RXD Output Supply Devices (SN65HVD256)

This device is a 5-V V_{CC} CAN transceiver with a separate supply for the RXD output, V_{RXD} . The digital inputs are 5-V and 3.3-V compatible. The SN65HVD256 device has a V_{RXD} level RXD output. TXD remains weakly pulled up to V_{CC} .

NOTE

On device versions with a V_{RXD} supply that shifts the RXD output level, the input pins of the device remain the same. TXD remains weakly pulled up to V_{CC} internally. Thus, a small I_{IH} current flows if the TXD input is used below V_{CC} levels.

9.4.5.3 5-V V_{CC} with FAULT Open-Drain Output Device (SN65HVD257)

The SN65HVD257 device has a FAULT output pin (open-drain). FAULT must be pulled up to V_{CC} or I/O supply level through an external resistor.

NOTE

Because the FAULT output pin is open-drain, it actively pulls down when there is no fault and becomes high-impedance when a fault condition is detected. An external pullup resistor to the V_{CC} or I/O supply of the system must be used to pull the pin high to indicate a fault to the host microprocessor. The open-drain architecture makes the fault pin compatible with 3.3-V and 5-V I/O-level systems. The pullup current, selected by the pullup resistance value, must be as low as possible while achieving the desired voltage level output in the system with margin against noise.

10 Application and Implementation

NOTE

Information in the following applications sections is not part of the TI component specification, and TI does not warrant its accuracy or completeness. TI's customers are responsible for determining suitability of components for their purposes. Customers should validate and test their design implementation to confirm system functionality.

10.1 Application Information

10.1.1 Bus Loading, Length, and Number of Nodes

The ISO 11898 standard states that a CAN bus should have a maximum of 30 nodes, be less than 40 meters from end to end, and should have no stubs greater than 0.3 meters. However, with careful design, users can have longer cables, longer stub lengths, and many more nodes to a bus. A large number of nodes requires a transceiver with high input impedance, such as the SN65HVD25x family devices.

Many CAN organizations and standards have scaled the use of CAN for applications outside the original ISO11898 standard. They have made system level trade-offs for data rate, cable length, and parasitic loading of the bus. Examples of some of these specifications are: ARINC825, CANopen, DeviceNet, and NMEA200.

A CAN network design is a series of trade-offs, but these devices operate over wide common-mode range. In ISO11898-2, the driver differential output is specified with a 60- Ω load (the two 120- Ω termination resistors in parallel) and the differential output must be greater than 1.5 V. The SN65HVD25x devices are specified to meet the 1.5-V requirement with a 45- Ω load incorporating the worst case including parallel transceivers. The differential input resistance of the SN65HVD25x devices is a minimum of 30 K Ω . If 167 SN65HVD25x family transceivers are in parallel on a bus, this is equivalent to a 180- Ω differential load worst case. That transceiver load of 180 Ω in parallel with the 60 Ω gives a total 45 Ω . Therefore, the SN65HVD25x family theoretically supports over 167 transceivers on a single bus segment with margin to the 1.2-V minimum differential input at each node. However, CAN network design margin must be given for signal loss across the system and cabling, parasitic loadings, network imbalances, ground offsets, and signal integrity; thus a practical maximum number of nodes is typically much lower. Bus length may also be extended beyond the original ISO11898 standard of 40 m by careful system design and data-rate tradeoffs. For example, CAN open network design guidelines allow the network to be up to 1 km with changes in the termination resistance, cabling, less than 64 nodes, and a significantly lowered data rate.

This flexibility in CAN network design is one of the key strengths of the various extensions and additional standards that have been built on the original ISO11898 CAN standard. In using this flexibility comes the responsibility of good network design and balancing these tradeoffs.

10.2 Typical Applications

10.2.1 Typical 5-V Microcontroller Application

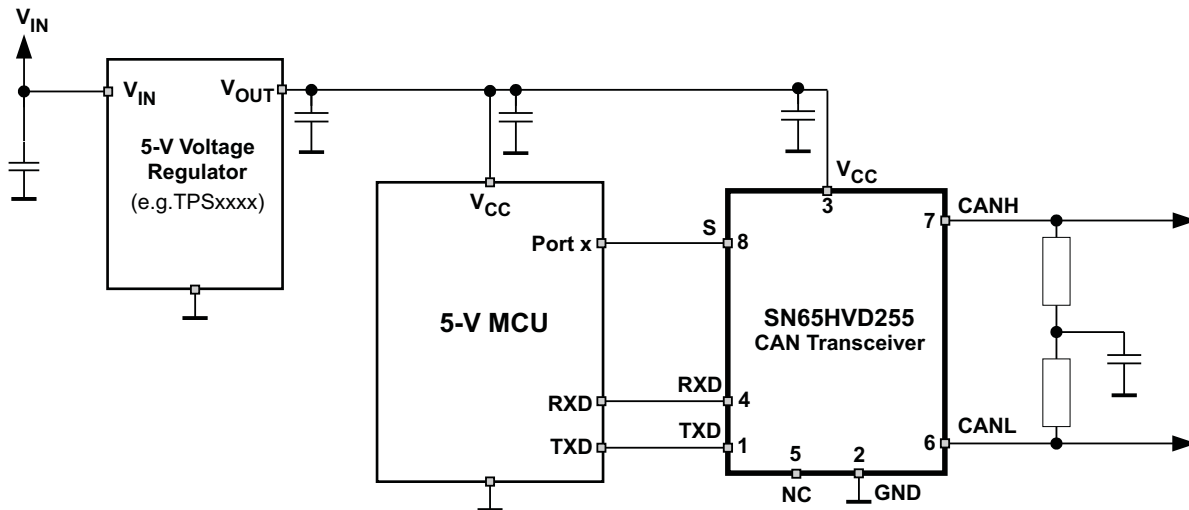

Figure 17. Typical 5-V Application

10.2.1.1 Design Requirements

10.2.1.1.1 CAN Termination

The ISO11898 standard specifies the interconnect to be a twisted-pair cable (shielded or unshielded) with 120- Ω characteristic impedance (Z_0). Resistors equal to the characteristic impedance of the line must be used to terminate both ends of the cable to prevent signal reflections. Unterminated drop lines (stubs) connecting nodes to the bus must be kept as short as possible to minimize signal reflections. The termination may be on the cable or in a node, but if nodes may be removed from the bus, the termination must be carefully placed so that it is not removed from the bus.

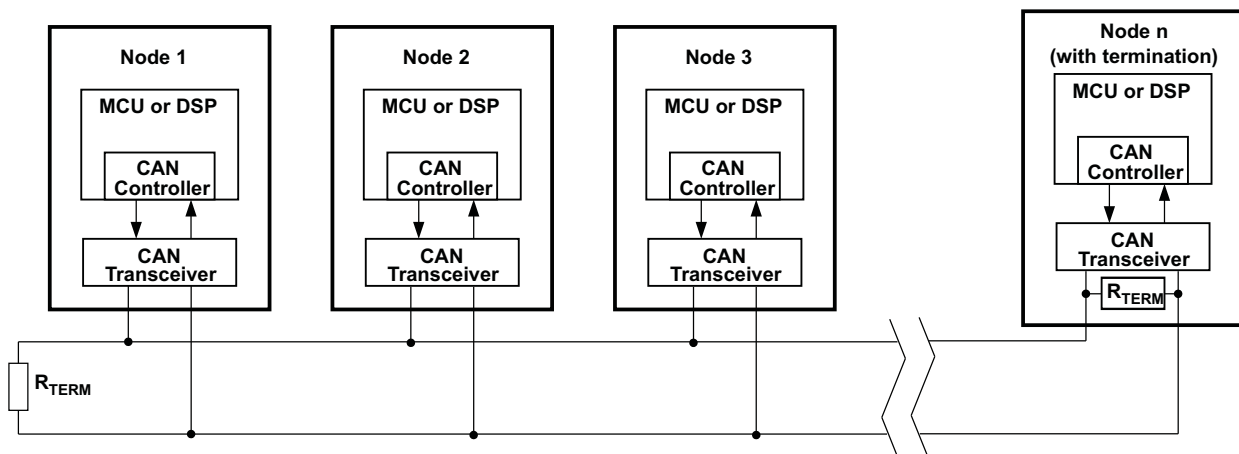
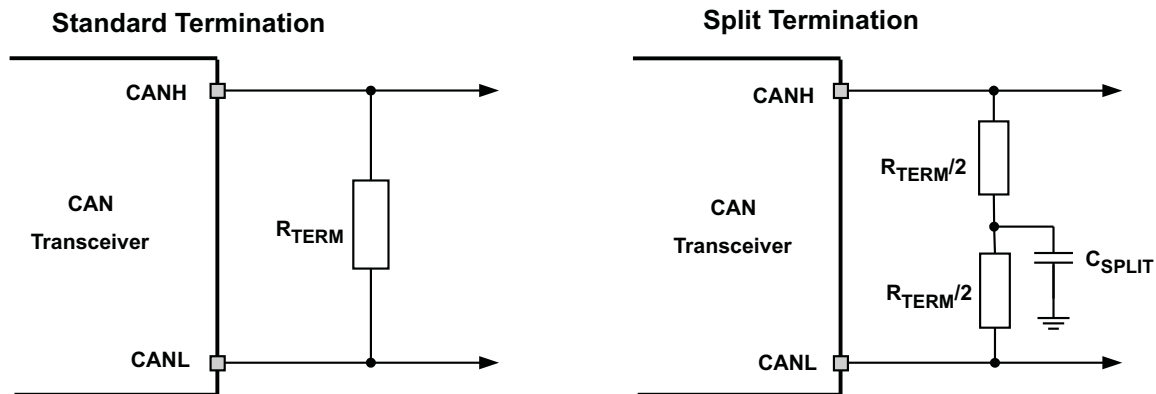

Figure 18. Typical CAN Bus

Termination may be a single 120- Ω resistor at the end of the bus either on the cable or in a terminating node. If filtering and stabilization of the common mode voltage of the bus is desired, then split termination may be used (see Figure 19). Split termination improves the electromagnetic emissions behavior of the network by eliminating fluctuations in the bus common-mode voltages at the start and end of message transmissions.

Typical Applications (continued)

Figure 19. CAN Bus Termination Concepts
10.2.1.2 Detailed Design Procedure
10.2.1.2.1 Example: Functional Safety Using the SN65HVD257 in a Redundant Physical Layer CAN Network Topology

CAN is a standard linear bus topology using 120-Ω twisted-pair cabling. The SN65HVD257 CAN device includes several features to use the CAN physical layer in nonstandard topologies with only one CAN link layer controller (μP) interface. This allows much greater flexibility in the physical topology of the bus while reducing the digital controller and software costs. The combination of RXD DTO and the FAULT output allows great flexibility, control, and monitoring of these applications.

A simple example of this flexibility is to use two SN65HVD257 devices in parallel with an AND gate to achieve redundancy (parallel) of the physical layer (cabling and PHYs) in a CAN network.

For the CAN bit-wise arbitration to work, the RXD outputs of the transceivers must connect through AND gate logic so that a dominant bit (low) from any of the branches is received by the link layer logic (μP) and appears to the link layer and above as a single physical network. The RXD DTO feature prevents a bus stuck dominant fault in a single branch from taking down the entire network by forcing the RXD pin for the transceivers on the branch with the fault back to the recessive after the $t_{\text{RXD_DTO}}$ time. The remaining branch of the network continues to function. The FAULT pin of the transceivers on the branch with the fault indicates this through the FAULT output to their host processors, which diagnose the failure condition. The S pin (silent mode pin) may be used to put a branch in silent mode to check each branch for other faults. Therefore, it is possible to implement a robust and redundant CAN network topology in a very simple and low-cost manner.

These concepts can be expanded into more complicated and flexible CAN network topologies to solve various system-level challenges with a networked infrastructure.

Typical Applications (continued)

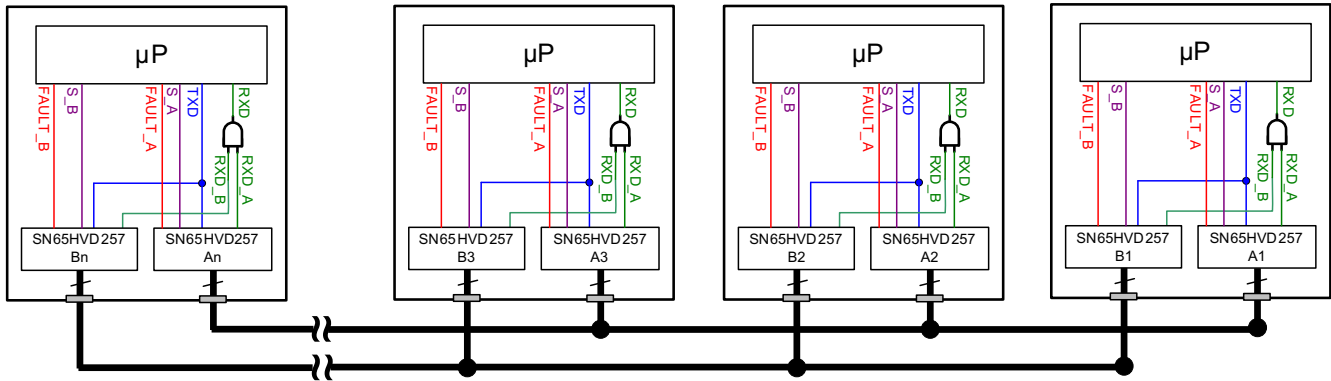

- A. CAN nodes with termination are PHY A, PHY B, PHY An and PHY Bn.
- B. RXD DTO prevents a single branch-stuck-dominant condition from blocking the redundant branch through the AND logic on RXD. The transceivers signal a received bus stuck dominant fault through the FAULT pin. The system detects which branch is stuck dominant and issues a system warning. Other network faults on a single branch that appear as recessive (not blocking the redundant network) may be detected through diagnostic routines and using the Silent Mode of the PHYs to use only one branch at a time for transmission during diagnostic mode. This combination allows robust fault detection and recovery within single branches so that they may be repaired and again provide redundancy of the physical layer.

Figure 20. Typical Redundant Physical Layer Topology Using the SN65HVD257 Device

10.2.1.3 Application Curves

Figure 21 shows the typical loop delay through the transceiver based on the differential resistive load between CANH and CANL.

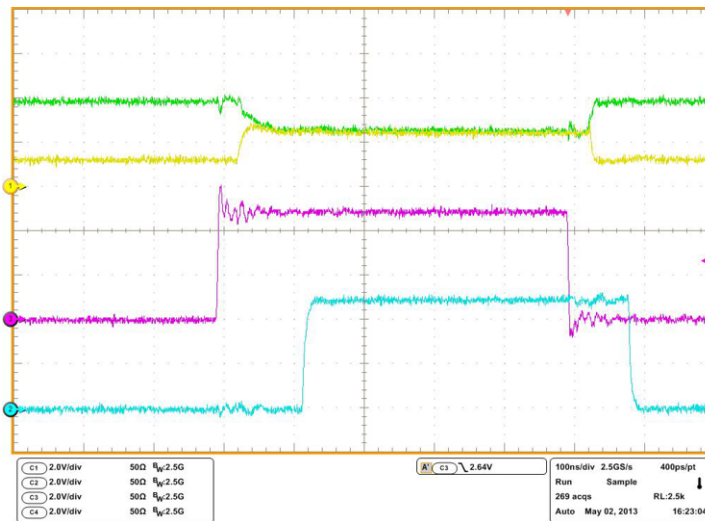

Figure 21. Typical TXD to RXD Loop Delay

Typical Applications (continued)

10.2.2 Typical 3.3-V Microcontroller Application

The SN65HVD256 device has a second supply voltage pin used for level shifting the input and output pins. This can be used for applications where there is a 3.3-V microcontroller and a 5-V CAN transceiver.

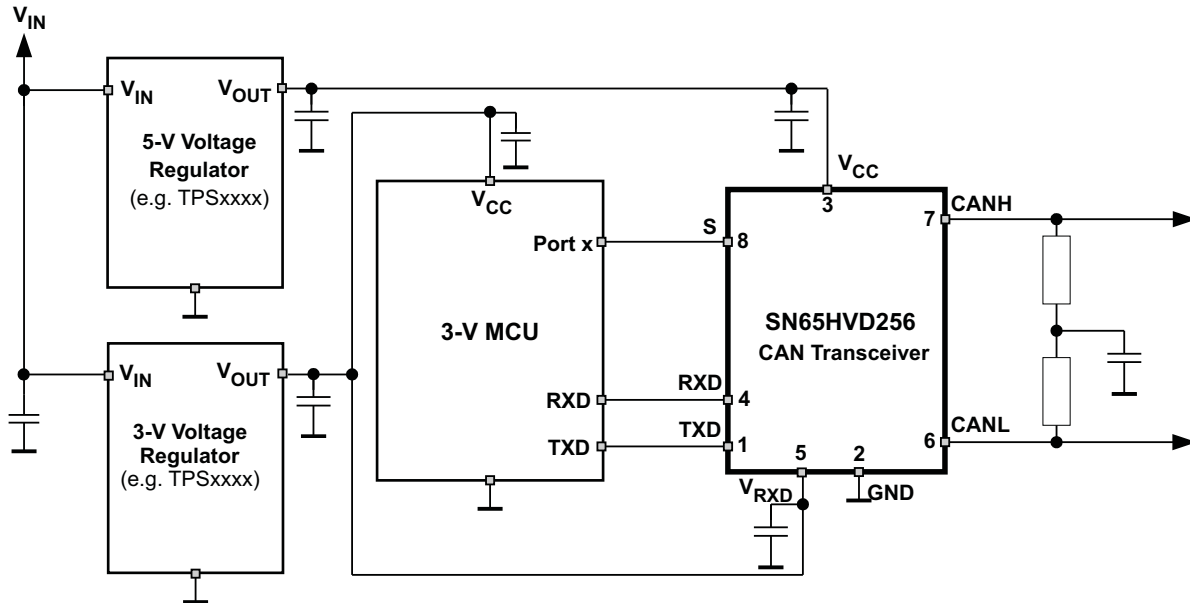

Figure 22. Typical 3.3-V Application

11 Power Supply Recommendations

To ensure reliable operation at all data rates and supply voltages, each supply must be decoupled with a 100-nF ceramic capacitor located as close as possible to the supply pins. The TPS76350 device is a linear voltage regulator suitable for the 5-V supply rail.

12 Layout

12.1 Layout Guidelines

For the PCB design to be successful, start with the design of the protection and filtering circuitry because ESD and EFT transients have a wide frequency bandwidth from approximately 3-MHz to 3-GHz and high frequency layout techniques must be applied during PCB design. On chip IEC ESD protection is good for laboratory and portable equipment but is usually not sufficient for EFT and surge transients occurring in industrial environments. Therefore, robust and reliable bus node design requires the use of external transient protection devices at the bus connectors. Placement at the connector also prevents these harsh transient events from propagating further into the PCB and system.

Use V_{CC} and ground planes to provide low inductance.

NOTE

High frequency current follows the path of least inductance and not the path of least resistance.

Design the bus protection components in the direction of the signal path. Do not force the transient current to divert from the signal path to reach the protection device. Below is a list of layout recommendations when designing a CAN transceiver into an application.

- **Transient Protection on CANH and CANL:** Transient Voltage Suppression (TVS) and capacitors (D1, C5 and C7 shown in [Figure 23](#)) can be used to protect the system level transients like EFT, IEC ESD, and Surge. These devices must be placed as close to the connector as possible. This prevents the transient energy and noise from penetrating into other nets on the board.
- **Bus Termination on CANH and CANL:** [Figure 23](#) shows split termination where the termination is split into two resistors, R5 and R6, with the center or split tap of the termination connected to ground through capacitor C6. Split termination provides common mode filtering for the bus. When termination is placed on the board instead of directly on the bus, care must be taken to ensure the terminating node is not removed from the bus, as this causes signal integrity issues if the bus is not properly terminated on both ends.
- **Decoupling Capacitors on V_{CC} and V_{RXD} :** Bypass and bulk capacitors must be placed as close as possible to the supply pins of transceiver (examples are C2, C3, C5, and C6).
- **Ground and power connections:** Use at least two vias for V_{CC} , V_{IO} , and ground connections of bypass capacitors and protection devices to minimize trace and via inductance.
- **Digital inputs and outputs:** To limit current of digital lines, serial resistors may be used. Examples are R1, R2, R3, R4, and R5.
- **Filtering noise on digital inputs and outputs:** To filter noise on the digital I/O lines, a capacitor may be used close to the input side of the I/O as shown by C1 and C4.
- **External pull-up resistors on input and output pins:** Because the internal pullup and pulldown biasing of the device is weak for floating pins, an external 1-k Ω to 10-k Ω pullup or pulldown resistor must be used to bias the state of the pins during transient events.
- **Fault Output Pin (SN65HVD257 only):** Because the FAULT output pin is an open drain output, an external pullup resistor is required to pull the pin voltage high for normal operation (R5).
- **V_{RXD} Supply (SN65HVD256 only):** The SN65HVD256 device will need additional bypass capacitors for the V_{RXD} supply shown with C5 and C6.
- **TXD input pin:** If an open-drain host processor is used to drive the TXD pin of the device, an external pullup resistor between 1 k Ω and 10 k Ω must be used to help drive the recessive input state of the device (weak internal pullup resistor).

12.2 Layout Example

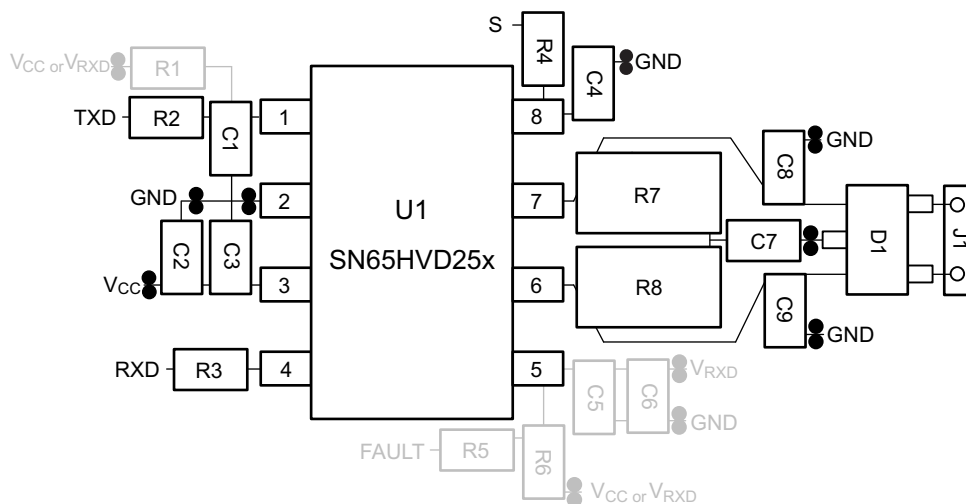

Figure 23. Layout Example

13 Device and Documentation Support

13.1 Related Links

The table below lists quick access links. Categories include technical documents, support and community resources, tools and software, and quick access to sample or buy.

Table 7. Related Links

PARTS	PRODUCT FOLDER	SAMPLE & BUY	TECHNICAL DOCUMENTS	TOOLS & SOFTWARE	SUPPORT & COMMUNITY
SN65HVD255	Click here	Click here	Click here	Click here	Click here
SN65HVD256	Click here	Click here	Click here	Click here	Click here
SN65HVD257	Click here	Click here	Click here	Click here	Click here

13.2 Trademarks

All trademarks are the property of their respective owners.

13.3 Electrostatic Discharge Caution



These devices have limited built-in ESD protection. The leads should be shorted together or the device placed in conductive foam during storage or handling to prevent electrostatic damage to the MOS gates.

13.4 Glossary

[SLYZ022](#) — *TI Glossary*.

This glossary lists and explains terms, acronyms, and definitions.

14 Mechanical, Packaging, and Orderable Information

The following pages include mechanical, packaging, and orderable information. This information is the most current data available for the designated devices. This data is subject to change without notice and revision of this document. For browser-based versions of this data sheet, refer to the left-hand navigation.

PACKAGING INFORMATION

Orderable Device	Status (1)	Package Type	Package Drawing	Pins	Package Qty	Eco Plan (2)	Lead finish/ Ball material (6)	MSL Peak Temp (3)	Op Temp (°C)	Device Marking (4/5)	Samples
SN65HVD255D	ACTIVE	SOIC	D	8	75	RoHS & Green	NIPDAU	Level-1-260C-UNLIM	-40 to 125	HVD255	Samples
SN65HVD255DR	ACTIVE	SOIC	D	8	2500	RoHS & Green	NIPDAU	Level-1-260C-UNLIM	-40 to 125	HVD255	Samples
SN65HVD256D	ACTIVE	SOIC	D	8	75	RoHS & Green	NIPDAU	Level-1-260C-UNLIM	-40 to 125	HVD256	Samples
SN65HVD256DR	ACTIVE	SOIC	D	8	2500	RoHS & Green	NIPDAU	Level-1-260C-UNLIM	-40 to 125	HVD256	Samples
SN65HVD257D	ACTIVE	SOIC	D	8	75	RoHS & Green	NIPDAU	Level-1-260C-UNLIM	-40 to 125	HVD257	Samples
SN65HVD257DR	ACTIVE	SOIC	D	8	2500	RoHS & Green	NIPDAU	Level-1-260C-UNLIM	-40 to 125	HVD257	Samples

(1) The marketing status values are defined as follows:

ACTIVE: Product device recommended for new designs.

LIFEBUY: TI has announced that the device will be discontinued, and a lifetime-buy period is in effect.

NRND: Not recommended for new designs. Device is in production to support existing customers, but TI does not recommend using this part in a new design.

PREVIEW: Device has been announced but is not in production. Samples may or may not be available.

OBSOLETE: TI has discontinued the production of the device.

(2) **RoHS:** TI defines "RoHS" to mean semiconductor products that are compliant with the current EU RoHS requirements for all 10 RoHS substances, including the requirement that RoHS substance do not exceed 0.1% by weight in homogeneous materials. Where designed to be soldered at high temperatures, "RoHS" products are suitable for use in specified lead-free processes. TI may reference these types of products as "Pb-Free".

RoHS Exempt: TI defines "RoHS Exempt" to mean products that contain lead but are compliant with EU RoHS pursuant to a specific EU RoHS exemption.

Green: TI defines "Green" to mean the content of Chlorine (Cl) and Bromine (Br) based flame retardants meet JS709B low halogen requirements of <=1000ppm threshold. Antimony trioxide based flame retardants must also meet the <=1000ppm threshold requirement.

(3) MSL, Peak Temp. - The Moisture Sensitivity Level rating according to the JEDEC industry standard classifications, and peak solder temperature.

(4) There may be additional marking, which relates to the logo, the lot trace code information, or the environmental category on the device.

(5) Multiple Device Markings will be inside parentheses. Only one Device Marking contained in parentheses and separated by a "~" will appear on a device. If a line is indented then it is a continuation of the previous line and the two combined represent the entire Device Marking for that device.

(6) Lead finish/Ball material - Orderable Devices may have multiple material finish options. Finish options are separated by a vertical ruled line. Lead finish/Ball material values may wrap to two lines if the finish value exceeds the maximum column width.

Important Information and Disclaimer: The information provided on this page represents TI's knowledge and belief as of the date that it is provided. TI bases its knowledge and belief on information provided by third parties, and makes no representation or warranty as to the accuracy of such information. Efforts are underway to better integrate information from third parties. TI has taken and continues to take reasonable steps to provide representative and accurate information but may not have conducted destructive testing or chemical analysis on incoming materials and chemicals. TI and TI suppliers consider certain information to be proprietary, and thus CAS numbers and other limited information may not be available for release.

In no event shall TI's liability arising out of such information exceed the total purchase price of the TI part(s) at issue in this document sold by TI to Customer on an annual basis.

TAPE AND REEL INFORMATION

QUADRANT ASSIGNMENTS FOR PIN 1 ORIENTATION IN TAPE

*All dimensions are nominal

Device	Package Type	Package Drawing	Pins	SPQ	Reel Diameter (mm)	Reel Width W1 (mm)	A0 (mm)	B0 (mm)	K0 (mm)	P1 (mm)	W (mm)	Pin1 Quadrant
SN65HVD255DR	SOIC	D	8	2500	330.0	12.4	6.4	5.2	2.1	8.0	12.0	Q1
SN65HVD256DR	SOIC	D	8	2500	330.0	12.4	6.4	5.2	2.1	8.0	12.0	Q1
SN65HVD257DR	SOIC	D	8	2500	330.0	12.4	6.4	5.2	2.1	8.0	12.0	Q1

TAPE AND REEL BOX DIMENSIONS

*All dimensions are nominal

Device	Package Type	Package Drawing	Pins	SPQ	Length (mm)	Width (mm)	Height (mm)
SN65HVD255DR	SOIC	D	8	2500	340.5	336.1	25.0
SN65HVD256DR	SOIC	D	8	2500	340.5	338.1	20.6
SN65HVD257DR	SOIC	D	8	2500	340.5	338.1	20.6

TUBE

*All dimensions are nominal

Device	Package Name	Package Type	Pins	SPQ	L (mm)	W (mm)	T (μm)	B (mm)
SN65HVD255D	D	SOIC	8	75	507	8	3940	4.32
SN65HVD256D	D	SOIC	8	75	507	8	3940	4.32
SN65HVD257D	D	SOIC	8	75	507	8	3940	4.32



D0008A

PACKAGE OUTLINE

SOIC - 1.75 mm max height

SMALL OUTLINE INTEGRATED CIRCUIT



4214825/C 02/2019

NOTES:

1. Linear dimensions are in inches [millimeters]. Dimensions in parenthesis are for reference only. Controlling dimensions are in inches. Dimensioning and tolerancing per ASME Y14.5M.
2. This drawing is subject to change without notice.
3. This dimension does not include mold flash, protrusions, or gate burrs. Mold flash, protrusions, or gate burrs shall not exceed .006 [0.15] per side.
4. This dimension does not include interlead flash.
5. Reference JEDEC registration MS-012, variation AA.

EXAMPLE BOARD LAYOUT

D0008A

SOIC - 1.75 mm max height

SMALL OUTLINE INTEGRATED CIRCUIT



LAND PATTERN EXAMPLE
 EXPOSED METAL SHOWN
 SCALE:8X



SOLDER MASK DETAILS

4214825/C 02/2019

NOTES: (continued)

- 6. Publication IPC-7351 may have alternate designs.
- 7. Solder mask tolerances between and around signal pads can vary based on board fabrication site.

EXAMPLE STENCIL DESIGN

D0008A

SOIC - 1.75 mm max height

SMALL OUTLINE INTEGRATED CIRCUIT



SOLDER PASTE EXAMPLE
BASED ON .005 INCH [0.125 MM] THICK STENCIL
SCALE:8X

4214825/C 02/2019

NOTES: (continued)

8. Laser cutting apertures with trapezoidal walls and rounded corners may offer better paste release. IPC-7525 may have alternate design recommendations.
9. Board assembly site may have different recommendations for stencil design.

IMPORTANT NOTICE AND DISCLAIMER

TI PROVIDES TECHNICAL AND RELIABILITY DATA (INCLUDING DATA SHEETS), DESIGN RESOURCES (INCLUDING REFERENCE DESIGNS), APPLICATION OR OTHER DESIGN ADVICE, WEB TOOLS, SAFETY INFORMATION, AND OTHER RESOURCES "AS IS" AND WITH ALL FAULTS, AND DISCLAIMS ALL WARRANTIES, EXPRESS AND IMPLIED, INCLUDING WITHOUT LIMITATION ANY IMPLIED WARRANTIES OF MERCHANTABILITY, FITNESS FOR A PARTICULAR PURPOSE OR NON-INFRINGEMENT OF THIRD PARTY INTELLECTUAL PROPERTY RIGHTS.

These resources are intended for skilled developers designing with TI products. You are solely responsible for (1) selecting the appropriate TI products for your application, (2) designing, validating and testing your application, and (3) ensuring your application meets applicable standards, and any other safety, security, regulatory or other requirements.

These resources are subject to change without notice. TI grants you permission to use these resources only for development of an application that uses the TI products described in the resource. Other reproduction and display of these resources is prohibited. No license is granted to any other TI intellectual property right or to any third party intellectual property right. TI disclaims responsibility for, and you will fully indemnify TI and its representatives against, any claims, damages, costs, losses, and liabilities arising out of your use of these resources.

TI's products are provided subject to [TI's Terms of Sale](#) or other applicable terms available either on [ti.com](https://www.ti.com) or provided in conjunction with such TI products. TI's provision of these resources does not expand or otherwise alter TI's applicable warranties or warranty disclaimers for TI products.

TI objects to and rejects any additional or different terms you may have proposed.

Mailing Address: Texas Instruments, Post Office Box 655303, Dallas, Texas 75265
Copyright © 2024, Texas Instruments Incorporated

Looking for pricing, stock, or lifecycle information?

Click below to explore more details on WIN SOURCE:

 [View SN65HVD255DEVM on WIN SOURCE](#)

 [Texas Instruments](#) Information

Optimize Your Supply Chain with WIN SOURCE Solutions

-  Global Sourcing Solution
-  Obsolete Management
-  Cost Control Management
-  Shortage Management
-  Alternative Solution
-  Excess Inventory Management