



**THE DATASHEET OF  
SI4022-A1-FT**





# Si4022 Universal ISM Band FSK Transmitter

## DESCRIPTION

Silicon Labs' Si4022 is a single chip, low power, multi-channel FSK transmitter designed for use in applications requiring FCC or ETSI conformance for unlicensed use in the bands at 868 and 915 MHz. Used in conjunction with Integration's FSK receivers, it is a flexible, low cost, and highly integrated solution that does not require production alignments. All required RF functions are integrated. Only an external crystal and bypass filtering is needed for operation.

The transmitter has a completely integrated PLL for easy RF design, and its rapid settling time allows for fast frequency-hopping, bypassing multipath fading and interference to achieve robust wireless links. The PLL's high resolution allows the usage of multiple channels in any of the bands. In addition, highly stable and accurate FSK modulation is accomplished by direct closed-loop modulation with bit rates up to 115.2 kbps.

The integrated power amplifier of the transmitter has an open-collector differential output and can directly drive a loop antenna with programmable output level, no additional matching network is required. An automatic antenna tuning circuit is built in to avoid both costly trimming procedures and de-tuning due to the "hand effect".

For battery-operated applications the device supports various power saving modes with wake-up interrupt generation options based on a low battery voltage detector and a sleep timer. Several additional features ease system design. Power-on reset and clock signals are provided to the microcontroller. An on-chip baud rate generator and a data FIFO are available. The transmitter is programmed and controlled via an SPI compatible interface.

## FUNCTIONAL BLOCK DIAGRAM

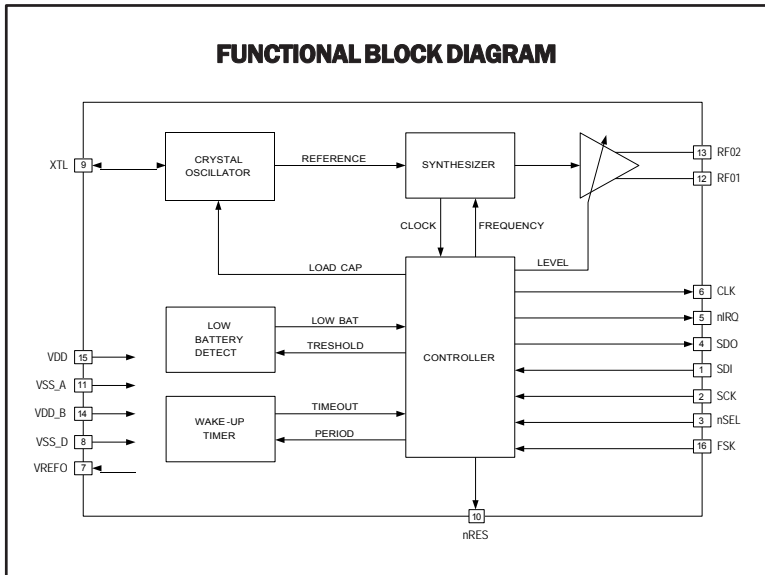

## Si4022

### PIN ASSIGNMENT

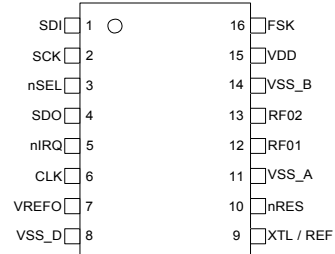

**This document refers to Si4022-IC Rev A0.**

See [www.silabs.com/integration](http://www.silabs.com/integration) for any applicable errata. See back page for ordering information.

## FEATURES

- Fully integrated (low BOM, easy design-in)
- No alignment required in production
- Fast settling, programmable, high-resolution PLL
- Fast frequency hopping capability
- Stable and accurate FSK modulation with programmable deviation
- Programmable PLL loop bandwidth
- Direct loop antenna drive
- Automatic antenna tuning circuit
- Programmable output power level
- SPI bus for interfacing with microcontroller
- Clock and reset signals for microcontroller
- 64 bit TX data FIFO
- Integrated programmable crystal load capacitor
- Standard 10 MHz crystal reference
- Power-saving modes
- Multiple event handling options for wake-up activation
- Wake-up timer
- Low battery detection
- 2.2 to 3.8 V supply voltage
- Low power consumption
- Low standby current (typ. 0.3  $\mu$ A)

## TYPICAL APPLICATIONS

- Remote control
- Home security and alarm
- Wireless keyboard/mouse and other PC peripherals
- Toy control
- Remote keyless entry
- Tire pressure monitoring
- Telemetry
- Personal/patient data logging
- Remote automatic meter reading



## DETAILED FEATURE-LEVEL DESCRIPTION

The Si4022 FSK transmitter is designed to cover the unlicensed frequency bands at 868, and 915 MHz. The device facilitates compliance with FCC and ETSI requirements.

### PLL

The programmable PLL synthesizer determines the operating frequency, while preserving accuracy based on the on-chip crystal-controlled reference oscillator. The PLL's high resolution allows the usage of multiple channels in any of the bands. The FSK deviation is selectable (from 20 to 160 kHz with 20 kHz increments) to accommodate various bandwidth, data rate and crystal tolerance requirements, and it is also highly accurate due to the direct closed-loop modulation of the PLL. The transmitted digital data can be sent asynchronously through the FSK pin or over the control interface using the appropriate command.

The RF VCO in the PLL performs automatic calibration, which requires only a few microseconds. To ensure proper operation in the programmed frequency band, the RF VCO is automatically calibrated upon activation of the synthesizer.

### RF Power Amplifier (PA)

The power amplifier has an open-collector differential output and can directly drive a loop antenna with a programmable output power level. An automatic antenna tuning circuit is built in to avoid costly trimming procedures and the so-called "hand effect."

### Crystal Oscillator and Microcontroller Clock Output

The chip has a single-pin crystal oscillator circuit, which provides a 10 MHz reference signal for the PLL. To reduce external parts and simplify design, the crystal load capacitor is internal and programmable. Guidelines for selecting the appropriate crystal can be found later in this datasheet. The transmitter can supply the clock signal for the microcontroller, so accurate timing is possible without the need for a second crystal. In normal operation it is divided from the reference 10 MHz. During sleep mode a low frequency (typical 32 kHz) output clock signal can be switched on.

When the microcontroller turns the crystal oscillator off by clearing the appropriate bit using the *Power Management Command*, the chip provides a certain number (default is 128) of further clock pulses ("clock tail") for the microcontroller to let it go to idle or sleep mode.

### Low Battery Voltage Detector

The low battery detector circuit monitors periodically (typ. 8 ms) the supply voltage and generates an interrupt if it falls below a programmable threshold level.

### Wake-Up Timer

The wake-up timer has very low current consumption (4  $\mu$ A max) and can be programmed from 1 ms to several hours.

It calibrates itself to the crystal oscillator at every startup and then at every 40 seconds with an accuracy of  $\pm 0.5\%$ . When the crystal oscillator is switched off, the calibration circuit switches it back on only long enough for a quick calibration (a few milliseconds) to facilitate accurate wake-up timing. The periodic autocalibration feature can be turned off.

### Event Handling

In order to minimize current consumption, the transmitter supports the sleep mode. Switching between the various modes is controlled by the appropriate bits in the *Power Management Command* (page 11).

Si4022 generates an interrupt signal on several events (wake-up timer timeout, low supply voltage detection, on-chip FIFO almost empty). This signal can be used to wake up the microcontroller, effectively reducing the period the microcontroller has to be active. The cause of the interrupt can be read out from the receiver by the microcontroller through the SDO pin.

### Interface and Controller

An SPI compatible serial interface lets the user select the frequency band, center frequency of the synthesizer, and the output power. Division ratio for the microcontroller clock, wake-up timer period, and low supply voltage detector threshold are also programmable. Any of these auxiliary functions can be disabled when not needed. All parameters are set to default after power-on; the programmed values are retained during sleep mode. The interface supports the read-out of a status register, providing detailed information about the status of the transmitter.

## PIN DEFINITION

Pin type key: D=digital, A=analog, S=supply, I=input, O=output, IO=input/output

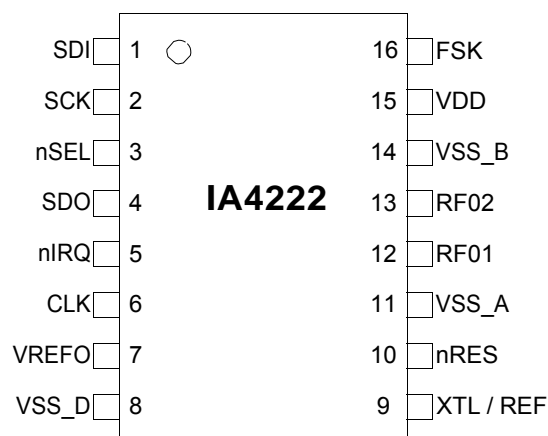

| Pin | Name      | Function | Type | Description   |
|-----|-----------|----------|------|---|
| 1   | SDI       | SDI      | DI   | Serial control / data input                           |
| 2   | SCK       | SCK      | DI   | Serial interface clock input                          |
| 3   | nSEL      | nSEL     | DI   | Chip (interface) select input (active low)            |
| 4   | SDO       | SDO      | DO   | Serial status data output                             |
| 5   | nIRQ      | nIRQ     | DO   | Interrupt request output (active low)                 |
| 6   | CLK       | CLK      | DO   | Clock output for the microcontroller                  |
| 7   | VREFO     | VREFO    | AO   | Voltage reference output                              |
| 8   | VSS_D     | VSS_D    | S    | Negative supply voltage (digital)                     |
| 9   | XTL / REF | XTL      | AIO  | Crystal connection (other terminal of crystal to VSS) |
|     |           | REF      | DI   | External reference input                              |
| 10  | nRES      | nRES     | DO   | Reset output (active low)                             |
| 11  | VSS_A     | VSS_A    | S    | Negative supply voltage (analog)                      |
| 12  | RFO1      | RFO1     | AO   | RF differential signal output (open collector)        |
| 13  | RFO2      | RFO2     | AO   | RF differential signal output (open collector)        |
| 14  | VSS_B     | VSS_B    | S    | Negative supply voltage (bulk)                        |
| 15  | VDD       | VDD      | S    | Positive supply voltage                               |
| 16  | FSK       | FSK      | DI   | Data input for asynchronous modulation                |

## GENERAL DEVICE SPECIFICATION

All voltages are referenced to  $V_{ss}$ , the potential on the ground reference pin VSS.

### Absolute Maximum Ratings (non-operating)

| Symbol   | Parameter                                     | Min  | Max          | Units |
|----------|---|------|--------------|-------|
| $V_{dd}$ | Positive supply voltage                       | -0.5 | 6.0          | V     |
| $V_{in}$ | Voltage on any pin                            | -0.5 | $V_{dd}+0.5$ | V     |
| $I_{in}$ | Input current into any pin except VDD and VSS | -25  | 25           | mA    |
| ESD      | Electrostatic discharge with human body model |      | 1000         | V     |
| $T_{st}$ | Storage temperature                           | -55  | 125          | °C    |
| $T_{ld}$ | Lead temperature (soldering, max 10 s)        |      | 260          | °C    |

### Recommended Operating Range

| Symbol   | Parameter                     | Min | Max | Units |
|----------|-------------------------------|-----|-----|-------|
| $V_{dd}$ | Positive supply voltage       | 2.2 | 3.8 | V     |
| $T_{op}$ | Ambient operating temperature | -40 | +85 | °C    |

## ELECTRICAL SPECIFICATION

(Min/max values are valid over the whole recommended operating range, typ conditions:  $T_{op} = 27\text{ °C}$ ;  $V_{dd} = V_{oc} = 2.7\text{ V}$ )

### DC Characteristics

| Symbol         | Parameter  | Conditions/Notes  | Min | Typ      | Max | Units |
|----------------|--|---|-----|----------|-----|-------|
| $I_{dd,TX0}$   | Supply current   | 868 MHz band, $P_{out} = 0\text{ dBm}$<br>915 MHz band, $P_{out} = 0\text{ dBm}$  |     | 14<br>15 |     | mA    |
| $I_{dd,TXmax}$ | Supply current   | 868 MHz band, $P_{out} = P_{max}$<br>915 MHz band, $P_{out} = P_{max}$            |     | 23<br>24 |     | mA    |
| $I_{pd}$       | Standby current (Note 1)                               | all blocks disabled   |     | 1        |     | μA    |
| $I_{lb}$       | Low battery voltage detector and wake-up timer current |   |     |          | 5   | μA    |
| $I_x$          | Idle current   | crystal oscillator is ON  |     | 0.5      |     | mA    |
| $V_{lb}$       | Low battery detection threshold                        | programmable in 0.1 V steps   | 2.0 |          | 3.5 | V     |
| $V_{lba}$      | Low battery detection accuracy                         |   |     | ± 0.05   |     | V     |
| $V_{POR}$      | $V_{dd}$ threshold required to generate a POR          |   |     | 1.5      |     | V     |
| $V_{POR,hyst}$ | POR hysteresis   | larger glitches on the $V_{dd}$ generate a POR even above the threshold $V_{POR}$ |     | 0.6      |     | V     |
| $SR_{Vdd}$     | $V_{dd}$ slew rate                                     | for proper POR generation   | 0.1 |          |     | V/ms  |

Note 1: Using a CR2032 battery (225 mAh capacity), the expected battery life is greater than 2 years using a 60-second wake-up period for sending 100 bytes packets in length at 19.2 kbps with +6 dBm output power in the 915 MHz band.

**DC Characteristics (continued)**

| Symbol   | Parameter                 | Conditions/Notes                     | Min                | Typ | Max                | Units   |
|----------|---------------------------|--------------------------------------|--------------------|-----|--------------------|---------|
| $V_{il}$ | Digital input low level   |                                      |                    |     | $0.3 \cdot V_{dd}$ | V       |
| $V_{ih}$ | Digital input high level  |                                      | $0.7 \cdot V_{dd}$ |     |                    | V       |
| $I_{il}$ | Digital input current     | $V_{il} = 0$ V                       | -1                 |     | 1                  | $\mu$ A |
| $I_{ih}$ | Digital input current     | $V_{ih} = V_{dd}$ , $V_{dd} = 3.8$ V | -1                 |     | 1                  | $\mu$ A |
| $V_{ol}$ | Digital output low level  | $I_{ol} = 2$ mA                      |                    |     | 0.4                | V       |
| $V_{oh}$ | Digital output high level | $I_{oh} = -2$ mA                     | $V_{dd} - 0.4$     |     |                    | V       |

**AC Characteristics**

| Symbol        | Parameter  | Conditions/Notes  | Min              | Typ | Max              | Units   |
|---------------|--|---|------------------|-----|------------------|---------|
| $f_{LO}$      | Transmitter frequency                                    | 868 MHz band, 20 kHz resolution<br>915 MHz band, 20 kHz resolution    | 801.92<br>881.92 |     | 878.06<br>958.06 | MHz     |
| $f_{ref}$     | PLL reference frequency                                  | (Note 1)  | 9                | 10  | 11               | MHz     |
| $f_{res}$     | PLL frequency resolution                                 |   |                  | 20  |                  | kHz     |
| $t_{lock}$    | PLL lock time  | Frequency error < 1kHz<br>after 1 MHz step                            |                  | 30  |                  | $\mu$ s |
| $t_{sp}$      | PLL startup time   | Initial calibration after power-up<br>with running crystal oscillator |                  |     | 500              | $\mu$ s |
| $C_{xl}$      | Crystal load capacitance,<br>see crystal selection guide | Programmable in 0.5 pF steps,<br>tolerance +/- 10%                    | 8.5              |     | 16               | pF      |
| $t_{POR}$     | Internal POR pulse width<br>(Note 2)                     | After $V_{dd}$ has reached 90% of<br>final value                      |                  | 50  | 100              | ms      |
| $t_{sx}$      | Crystal oscillator startup time                          | Crystal ESR < 100 $\Omega$  |                  | 2   | 5                | ms      |
| $t_{PBt}$     | Wake-up timer clock period                               | Calibrated every 40 seconds<br>(Note 3)                               | 0.995            | 1   | 1.005            | ms      |
| $t_{wake-up}$ | Programmable wake-up time                                |   | 1                |     | $8.4 \cdot 10^6$ | ms      |

Note 1: Using anything but a 10 MHz crystal is allowed but not recommended because all crystal-referred timing and frequency parameters will change accordingly.

Note 2: No command are accepted by the chip during this period.

Note 3: Autocalibration can be turned off.

**AC Characteristics (continued)**

| Symbol           | Parameter                                | Conditions/Notes                                    | Min            | Typ         | Max       | Units  |
|------------------|--|---|----------------|-------------|-----------|--------|
| BR               | FSK bit rate                             | (Note 4)  |                |             | 115.2     | kbps   |
| $I_{out}$        | Open collector output current            | Adjustable in 8 steps                               | 0.5            |             | 6         | mA     |
| $P_{max}$        | Available output power                   | With optimal antenna impedance (Note 5)             |                | 6           |           | dBm    |
| $P_{out}$        | Typical output power                     | Adjustable in 8 steps (3 dB/step)                   | $P_{max} - 21$ |             | $P_{max}$ | dBm    |
| $P_{sp}$         | Spurious emission                        | Out of band, EIRP (Note 6)                          |                |             | -52       | dBm    |
| $C_{out}$        | Output capacitance                       | Set by the automatic antenna tuning circuit         | 1.6            | 2.2         | 2.8       | pF     |
| $Q_{out}$        | Quality factor of the output capacitance |   | 16             | 18          | 22        |        |
| $L_{out}$        | Output phase noise                       | 100 kHz from carrier<br>1 MHz from carrier (Note 4) |                | -85<br>-105 |           | dBc/Hz |
| $C_{in,D}$       | Digital input capacitance                |   |                |             | 2         | pF     |
| $t_{r,f}$        | Digital output rise/fall time            | 15 pF pure capacitive load                          |                |             | 10        | ns     |
| $t_{r,f,ckout}$  | Clock output rise/fall time              | 10 pF pure capacitive load                          |                |             | 15        | ns     |
| $f_{ckout,slow}$ | Slow clock frequency                     | Tolerance +/- 1 kHz                                 |                | 32          |           | kHz    |

| Setting (bw1, bw0) | Max. data rate [kbps] | Phase noise at 1 MHz offset [dBc/Hz] | PLL bandwidth        |
|--------------------|-----------------------|--------------------------------------|----------------------|
| 00                 | 19.2                  | -112                                 | 15 kHz               |
| 01                 | 38.4                  | -110                                 | 30 kHz               |
| 10                 | 64                    | -107                                 | 60 kHz (POR default) |
| 11                 | 115.2                 | -102                                 | 120 kHz              |

| Band    | $Y_{antenna}$ [S]   | $Z_{antenna}$ [ $\Omega$ ] | $L_{antenna}$ [nH] |
|---------|---------------------|----------------------------|--------------------|
| 868 MHz | $1.35E-3 - j1.2E-2$ | $9 + j82$                  | 15.2               |
| 915 MHz | $1.45E-3 - j1.3E-2$ | $8.7 + j77$                | 13.6               |

Note 4: The maximum FSK bitrate and the output phase noise are dependent on the PLL settings (with the *Extended Features Command*).

Note 5: Optimal antenna / admittance / inductance for the Si4022

Note 6: With selective resonant antennas (see: Application Notes available from <http://www.silabs.com/integration>).

**TYPICAL PERFORMANCE DATA**

**Phase noise measurements in the 868 MHz ISM band**

**50% Charge pump current setting  
(Ref. level: -60 dBc/Hz, 10 dB/div)**

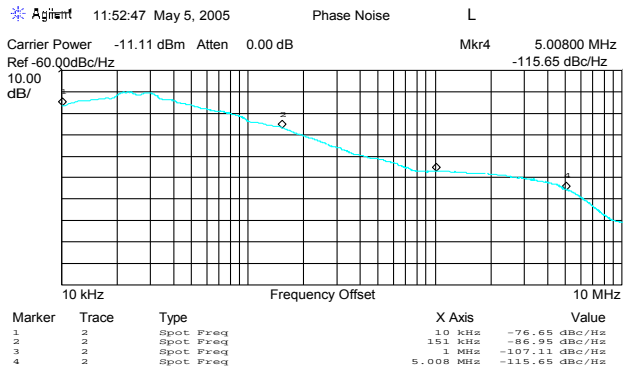

**100, 50, 33% Charge pump current settings  
(Ref. level: -70 dBc/Hz, 5 dB/div)**

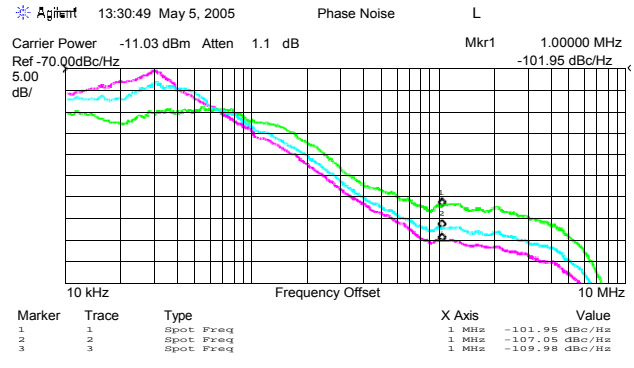

**Unmodulated RF Spectrum**

The output spectrum is measured at different frequencies. The output is loaded with 50 Ohm through a matching network.

**At 868 MHz**

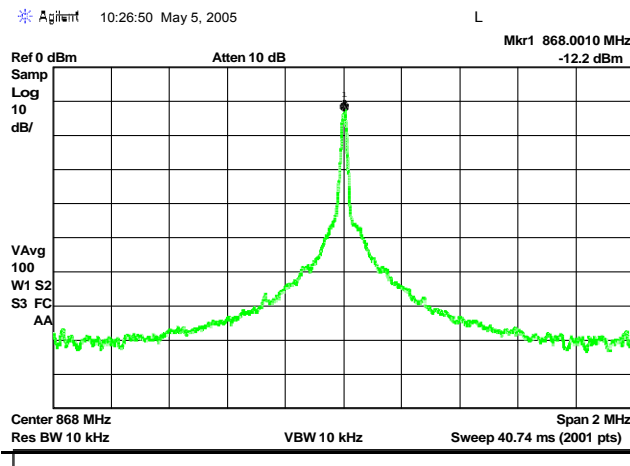

**At 915 MHz**

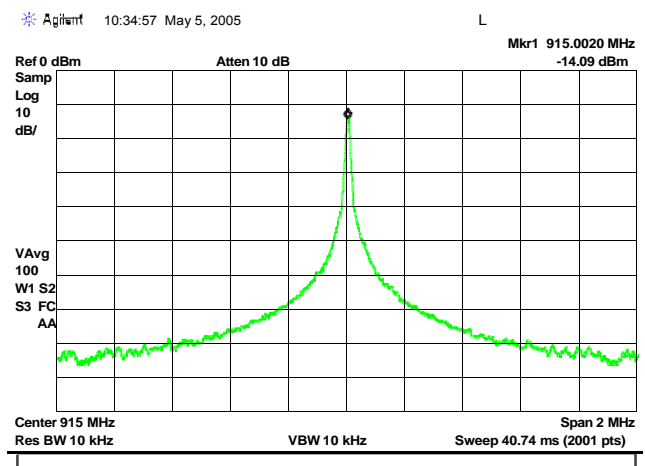

**At 868 MHz with  
180 kHz Deviation at 9.6 kbps**

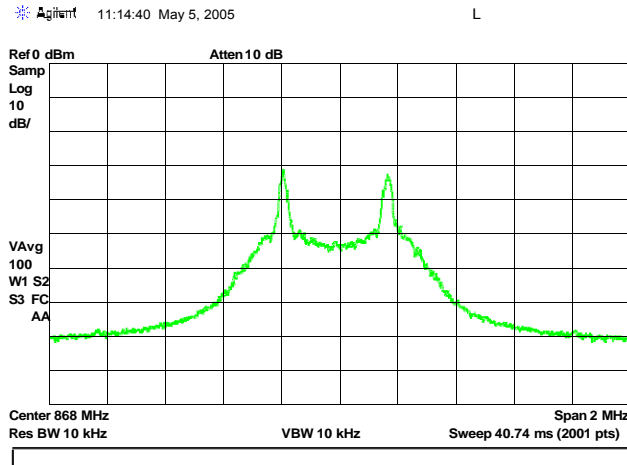

**Antenna Tuning Characteristics  
750-970 MHz**

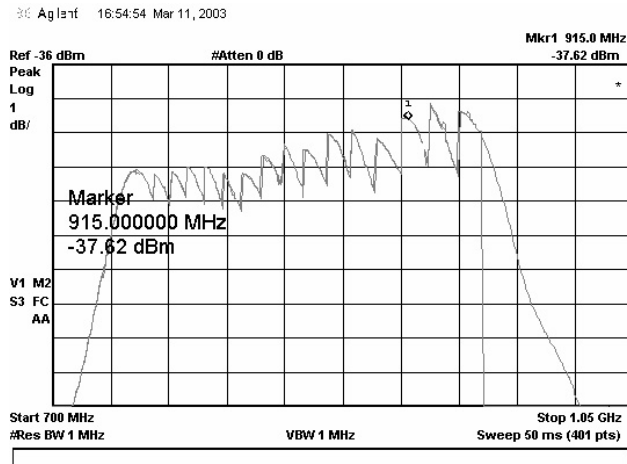

The antenna tuning characteristics was recorded in “max-hold” state of the spectrum analyzer. During the measurement, the transmitters were forced to change frequencies by forcing an external reference signal to the XTL pin. While the carrier was changing the antenna tuning circuit switched through all the available states of the tuning circuit. The graph clearly demonstrates that while the complete output circuit had about a 40 MHz bandwidth, the tuning allows operating in a 220 MHz band. In other words the tuning circuit can compensate for 25% variation in the resonant frequency due to any process or manufacturing spread.

## CONTROL INTERFACE

Commands to the transmitters are sent serially. Data bits on pin SDI are shifted into the device upon the rising edge of the clock on pin SCK whenever the chip select pin nSEL is low. When the nSEL signal is high, it initializes the serial interface. The number of bits sent is an integer multiple of 8 (except for the *Transmitter FIFO Write Command*). All commands consist of a command code, followed by a varying number of parameter or data bits. All data are sent MSB first (e.g. bit 15 for a 16-bit command). Bits having no influence (don't care) are indicated with X. The Power On Reset (POR) circuit sets default values in all control and command registers.

### Timing Specification

| Symbol    | Parameter  | Minimum value [ns] |
|-----------|--|--------------------|
| $t_{CH}$  | Clock high time  | 25                 |
| $t_{CL}$  | Clock low time   | 25                 |
| $t_{SS}$  | Select setup time (nSEL falling edge to SCK rising edge) | 10                 |
| $t_{SH}$  | Select hold time (SCK falling edge to nSEL rising edge)  | 10                 |
| $t_{SHI}$ | Select high time   | 25                 |
| $t_{DS}$  | Data setup time (SDI transition to SCK rising edge)      | 5                  |
| $t_{DH}$  | Data hold time (SCK rising edge to SDI transition)       | 5                  |
| $t_{OD}$  | Data delay time  | 10                 |

### Timing Diagram

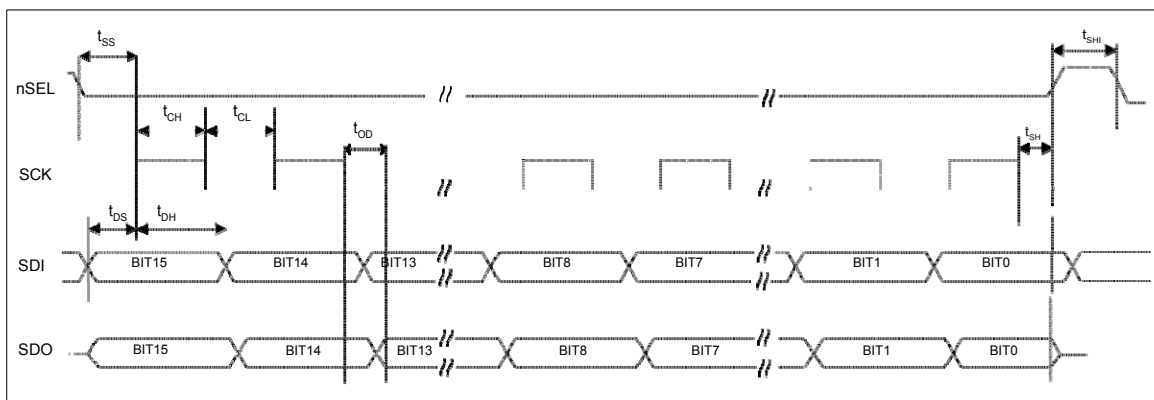

## Control Commands

| Control Word  | Related Parameters/Functions   |
|---|--|
| Configuration Setting Command                         | frequency band and deviation, output power, crystal oscillator load capacitance                            |
| Frequency Setting Command                             | frequency of the local oscillator  |
| Power Management Command                              | crystal oscillator, synthesizer, power amplifier, low battery detector, wake-up timer, clock output buffer |
| Transmitter FIFO Write Command                        | transmitter FIFO write   |
| FIFO Setting Command                                  | FIFO functions   |
| Data Rate Command                                     | bit rate   |
| Low Battery and Microcontroller Clock Divider Command | LBD voltage threshold and microcontroller clock division ratio   |
| Wake-up Timer Command                                 | wake-up time period  |
| Extended Wake-up Timer Command                        | wake-up time period finer adjustment   |
| Extended Features Command                             | low frequency output clock, wake-up timer extra functions  |
| Status Register Read Command                          | transmitter status read  |

Note: In the following tables the POR column shows the default values of the command registers after power-on.

## Configuration Setting Command

| bit | 15 | 14 | 13 | 12 | 11 | 10 | 9  | 8  | 7  | 6  | 5  | 4  | 3  | 2  | 1  | 0  | POR   |
|-----|----|----|----|----|----|----|----|----|----|----|----|----|----|----|----|----|-------|
|     | 1  | 0  | 0  | 1  | bs | p2 | p1 | p0 | x3 | x2 | x1 | x0 | ms | m2 | m1 | m0 | 9082h |

| bs | Frequency Band [MHz] |
|----|----------------------|
| 0  | 868                  |
| 1  | 915                  |

| p2 | p1 | p0 | Output Power [dBm] |
|----|----|----|--------------------|
| 0  | 0  | 0  | 0                  |
| 0  | 0  | 1  | -3                 |
| 0  | 1  | 0  | -6                 |
| 0  | 1  | 1  | -9                 |
| 1  | 0  | 0  | -12                |
| 1  | 0  | 1  | -15                |
| 1  | 1  | 0  | -18                |
| 1  | 1  | 1  | -21                |

| x3    | x2 | x1 | x0 | Crystal Load Capacitance [pF] |
|-------|----|----|----|-------------------------------|
| 0     | 0  | 0  | 0  | 8.5                           |
| 0     | 0  | 0  | 1  | 9.0                           |
| 0     | 0  | 1  | 0  | 9.5                           |
| 0     | 0  | 1  | 1  | 10.0                          |
| ..... |    |    |    | ....                          |
| 1     | 1  | 1  | 0  | 15.5                          |
| 1     | 1  | 1  | 1  | 16.0                          |

The output power is given in the table as relative to the maximum available power, which depends on the actual antenna impedance. (See: Antenna Application Note available from <http://www.silabs.com/integration>).

The resulting output frequency can be calculated as:

$$f_{out} = f_o - (-1)^{SIGN} * (M + 1) * (20 \text{ kHz})$$

where:

$f_o$  is the channel center frequency (see the next command)

M is the three bit binary number <m2 : m0>

SIGN = (ms) XOR (FSK input)

## Frequency Setting Command

|     |    |    |    |    |     |     |    |    |    |    |    |    |    |    |    |    |       |
|-----|----|----|----|----|-----|-----|----|----|----|----|----|----|----|----|----|----|-------|
| bit | 15 | 14 | 13 | 12 | 11  | 10  | 9  | 8  | 7  | 6  | 5  | 4  | 3  | 2  | 1  | 0  | POR   |
|     | 1  | 0  | 1  | 0  | f11 | f10 | f9 | f8 | f7 | f6 | f5 | f4 | f3 | f2 | f1 | f0 | AD57h |

The 12-bit parameter of the *Frequency Setting Command* <f11 : f0> has the value F. The value F should be in the range of 96 and 3903. When F is out of range, the previous value is kept. The synthesizer center frequency  $f_0$  can be calculated as:

$$f_0 = 8 * 10 \text{ MHz} * (C + F/4000)$$

The constant C is determined by the selected band as:

| Band [MHz] | C  |
|------------|----|
| 868        | 10 |
| 915        | 11 |

## Power Management Command

|     |    |    |    |    |    |    |   |   |   |   |    |    |     |    |    |    |       |
|-----|----|----|----|----|----|----|---|---|---|---|----|----|-----|----|----|----|-------|
| bit | 15 | 14 | 13 | 12 | 11 | 10 | 9 | 8 | 7 | 6 | 5  | 4  | 3   | 2  | 1  | 0  | POR   |
|     | 1  | 1  | 0  | 0  | 0  | 0  | 0 | 0 | 0 | 0 | ex | es | etr | eb | et | dc | C002h |

Bit 5 <ex>: Enables the the crystal oscillator.

Bit 4 <es>: Enables the synthesizer.

Bit 3 <etr>: Enables the power amplifier. If the ex and es bit is not set, it switches on the crystal oscillator and the synthesizer as well.  
In FIFO mode (bit fe is set in the *FIFO Setting Command*) setting this bit will roll out the content of the FIFO.

Bit 2 <eb>: Enables the low battery detector.

Bit 1 <et>: Enables the wake-up timer.

Bit 0 <dc>: Disables the clock output buffer.

**Note:** If faster operation is needed, then leave ex and es bit set to '1' and toggle only the etr bit.

## Power Saving Modes

The different operating modes of the chip depend on the following control bits:

| Operating Mode    | eb or et | es | etr | ex |
|-------------------|----------|----|-----|----|
| Active (transmit) | X        | x  | 1   | x  |
| Idle              | X        | 0  | 0   | 1  |
| Sleep             | 1        | 0  | 0   | 0  |
| Standby           | 0        | 0  | 0   | 0  |

## Transmitter FIFO Write Command

|     |   |   |   |   |   |   |   |   |     |
|-----|---|---|---|---|---|---|---|---|-----|
| Bit | 7 | 6 | 5 | 4 | 3 | 2 | 1 | 0 | POR |
|     | 1 | 1 | 0 | 0 | 0 | 1 | 1 | 0 | -   |

With this command, the controller can write databits to the transmitter FIFO. Bit (fe) must be set in the *FIFO Setting Command*.

## Transmitter FIFO register write

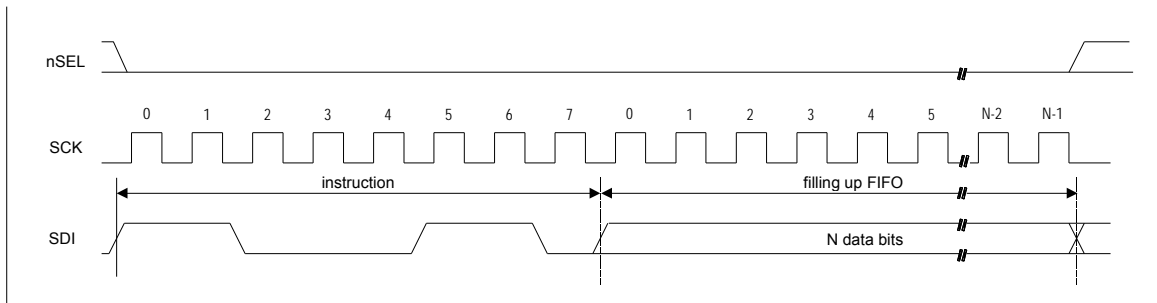

## Data Transmit Sequence Through the FSK Pin

It is possible to transmit data without the FIFO by using the FSK input pin. In that case the power amplifier should be enabled first with the *Power Management Command*.

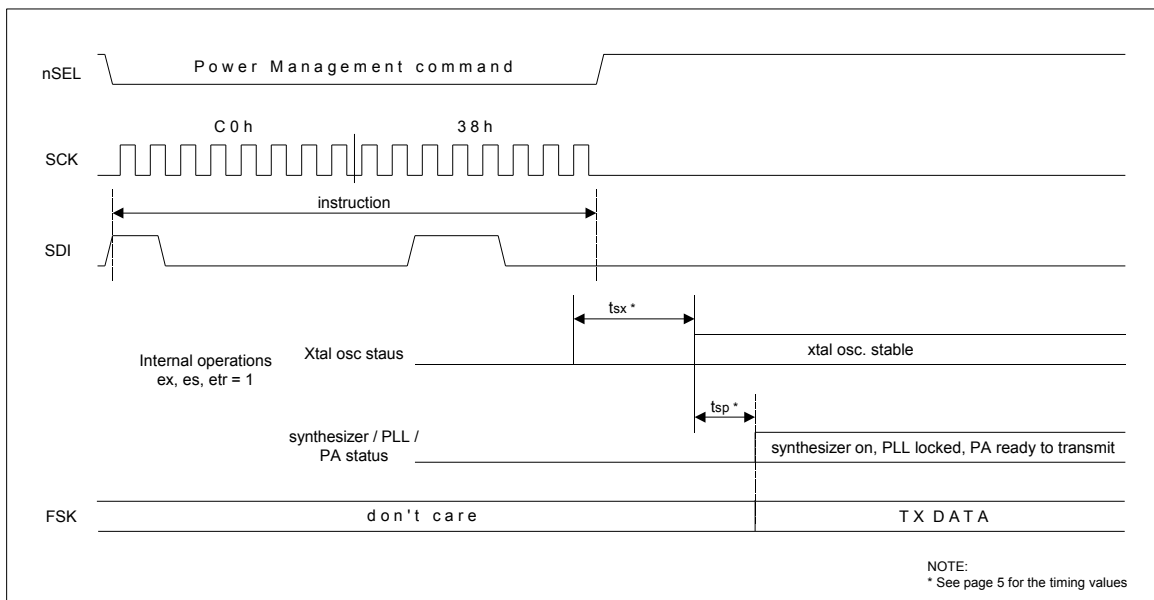

### Note:

- If the crystal oscillator was formerly switched off ( $ex=0$ ), the internal oscillator needs  $t_{sx}$  time, to switch on. The actual value depends on the type of quartz crystal used.
- If the synthesizer was formerly switched off ( $es=0$ ), the internal PLL needs  $t_{sp}$  startup time. Valid data can be transmitted only when the internal locking process is finished.

## FIFO Setting Command

|     |    |    |    |    |    |    |   |   |    |   |    |    |    |    |    |    |       |
|-----|----|----|----|----|----|----|---|---|----|---|----|----|----|----|----|----|-------|
| bit | 15 | 14 | 13 | 12 | 11 | 10 | 9 | 8 | 7  | 6 | 5  | 4  | 3  | 2  | 1  | 0  | POR   |
|     | 1  | 1  | 0  | 0  | 1  | 1  | 1 | 0 | fe | 0 | f5 | f4 | f3 | f2 | f1 | f0 | CE00h |

Bit 7 <fe>: Enables the 64 bit transmit FIFO. Resetting this bit clears the contents of the FIFO.

Bit 5-0 <f5 : f0>: FIFO IT level. The FIFO generates IT when number of the remaining data bits in the FIFO reaches this level.

## Data Rate Command

|     |    |    |    |    |    |    |   |   |    |    |    |    |    |    |    |    |       |
|-----|----|----|----|----|----|----|---|---|----|----|----|----|----|----|----|----|-------|
| bit | 15 | 14 | 13 | 12 | 11 | 10 | 9 | 8 | 7  | 6  | 5  | 4  | 3  | 2  | 1  | 0  | POR   |
|     | 1  | 1  | 0  | 0  | 1  | 0  | 0 | 0 | cs | r6 | r5 | r4 | r3 | r2 | r1 | r0 | C813h |

The bit rate of the transmitted data stream is determined by the 7-bit value R (bits r6 to r0) and the 1 bit cs.

$$BR = 10 \text{ MHz} / 29 / (R+1) / (1 + cs*7)$$

In the receiver set R according to the next function:

$$R = (10 \text{ MHz} / 29 / (1 + cs*7) / BR) - 1$$

Apart from setting custom values, the standard bit rates from 600 bps to 115.2 kbps can be approximated with small error.

## Low Battery and Microcontroller Clock Divider Command

|     |    |    |    |    |    |    |   |   |    |    |    |      |    |    |    |    |       |
|-----|----|----|----|----|----|----|---|---|----|----|----|------|----|----|----|----|-------|
| bit | 15 | 14 | 13 | 12 | 11 | 10 | 9 | 8 | 7  | 6  | 5  | 4    | 3  | 2  | 1  | 0  | POR   |
|     | 1  | 1  | 0  | 0  | 0  | 0  | 1 | 0 | d2 | d1 | d0 | elfc | t3 | t2 | t1 | t0 | C213h |

The 4-bit value T of t3-t0 determines the threshold voltage of the threshold voltage  $V_{lb}$  of the detector:

$$V_{lb} = 2.0 \text{ V} + T * 0.1 \text{ V}$$

Bit 4 <elfc>: Enables low frequency (32 kHz) microcontroller output clock during sleep mode.

Clock divider configuration (valid only if the crystal oscillator is on):

| d2 | d1 | d0 | Clock Output Frequency [MHz] |
|----|----|----|------------------------------|
| 0  | 0  | 0  | 1                            |
| 0  | 0  | 1  | 1.25                         |
| 0  | 1  | 0  | 1.66                         |
| 0  | 1  | 1  | 2                            |
| 1  | 0  | 0  | 2.5                          |
| 1  | 0  | 1  | 3.33                         |
| 1  | 1  | 0  | 5                            |
| 1  | 1  | 1  | 10                           |

## Wake-Up Timer Command

|     |    |    |    |    |    |    |    |    |    |    |    |    |    |    |    |    |       |
|-----|----|----|----|----|----|----|----|----|----|----|----|----|----|----|----|----|-------|
| bit | 15 | 14 | 13 | 12 | 11 | 10 | 9  | 8  | 7  | 6  | 5  | 4  | 3  | 2  | 1  | 0  | POR   |
|     | 1  | 1  | 1  | 0  | r3 | r2 | r1 | r0 | m7 | m6 | m5 | m4 | m3 | m2 | m1 | m0 | E196h |

The wake-up time period can be calculated by M <m13 : m0>, R <r3 : r0> and D <d1 : d0>:

$$T_{\text{wake-up}} = M * 2^{R-D} \text{ ms}$$

Note: • The wake-up timer generates interrupts continuously at the programmed interval while the et bit is set.

### Extended Wake-Up Timer Command

|     |    |    |    |    |    |    |   |   |    |    |     |     |     |     |    |    |       |
|-----|----|----|----|----|----|----|---|---|----|----|-----|-----|-----|-----|----|----|-------|
| bit | 15 | 14 | 13 | 12 | 11 | 10 | 9 | 8 | 7  | 6  | 5   | 4   | 3   | 2   | 1  | 0  | POR   |
|     | 1  | 1  | 0  | 0  | 0  | 0  | 1 | 1 | d1 | d0 | m13 | m12 | m11 | m10 | m9 | m8 | C300h |

These bits can be used for further fine adjustment of the wake-up timer. The explanation of the bits can be found above.

### Extended Features Command:

|     |    |    |    |    |    |    |   |   |     |      |   |      |     |     |      |     |       |
|-----|----|----|----|----|----|----|---|---|-----|------|---|------|-----|-----|------|-----|-------|
| bit | 15 | 14 | 13 | 12 | 11 | 10 | 9 | 8 | 7   | 6    | 5 | 4    | 3   | 2   | 1    | 0   | POR   |
|     | 1  | 0  | 1  | 1  | 0  | 0  | 0 | 0 | exp | ctls | 0 | dcal | bw1 | bw0 | dsfi | ewi | B0CAh |

Bit 7 <exp>: Enables low power mode for the crystal oscillator.

Bit 6 <ctls>: Clock tail selection bit. Setting this bit selects 512 cycle long clock tail instead of the default 128.

Bit 4 <dcal>: Disables the wake-up timer autocalibration.

Bit 3-2 <bw1:bw0>: Select the bandwidth of the PLL.

| bw1 | bw0 | PLL bandwidth |
|-----|-----|---------------|
| 0   | 0   | 15 kHz        |
| 0   | 1   | 30 kHz        |
| 1   | 0   | 60 kHz        |
| 1   | 1   | 120 kHz       |

Bit 1 <dsfi>: Disables autosleep on FIFO interrupt if set to 1.

Bit 0 <ewi>: Enables the automatic wake-up on any interrupt event.

### Status Register Read Command

|     |    |    |    |    |    |    |   |   |   |   |   |   |   |   |   |   |     |
|-----|----|----|----|----|----|----|---|---|---|---|---|---|---|---|---|---|-----|
| bit | 15 | 14 | 13 | 12 | 11 | 10 | 9 | 8 | 7 | 6 | 5 | 4 | 3 | 2 | 1 | 0 | POR |
|     | 0  | 0  | 0  | 0  | 0  | 0  | 0 | 0 | 0 | 0 | 0 | 0 | 0 | 0 | 0 | 0 | -   |

With this command, it is possible to read the status register of the chip through the SDO pin.

|       |   |
|-------|---|
| FFIT  | The number of data bits in the FIFO has gone below the preprogrammed limit    |
| FFEM  | FIFO is empty   |
| FFOV  | FIFO overflow   |
| LBD   | Low battery detect, the power supply voltage is below the preprogrammed limit |
| WK-UP | Wake-up timer overflow  |
| POR   | Power-on reset  |

**Status Register Read Sequence**

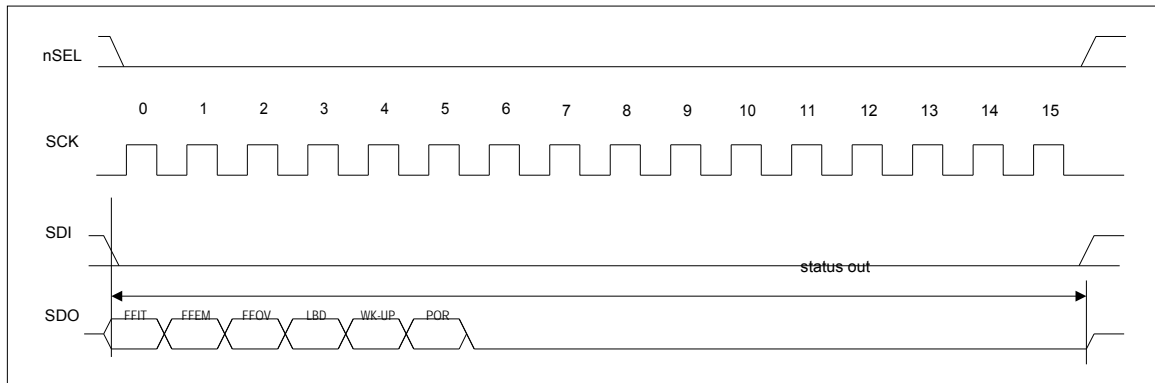

## Dual Clock Output

When the chip is switched into idle mode, the 10 MHz crystal oscillator starts. After oscillation ramp-up a 1 MHz clock signal is available on the CLK pin. This (fast) clock frequency can be reprogrammed during operation with the *Low Battery and Microcontroller Clock Divider Command* (page13). During startup and in sleep or standby mode (crystal oscillator disabled), the CLK output is pulled to logic low.

On the same pin a low frequency clock signal can be obtained if the *elrc* bit is set in the *Low Battery and Microcontroller Clock Divider Command*. The clock frequency is 32 kHz which is derived from the low-power RC oscillator of the wake-up timer. In order to use this slow clock the wake-up timer should be enabled by setting the *et* bit in the *Power Management Command* (page 11) even if the wake-up timer itself is not used.

Slow clock feature can be enabled by entering into sleep mode (page 11). Driving the output will increase the sleep mode supply current. Actual worst-case value can be determined when the exact load and min/max operating conditions are defined. After power-on reset the chip goes into sleep mode and the slow frequency clock appears on the CLK pin.

Switching back into fast clock mode can be done by setting the *ex* or *etr* bits in the appropriate commands. It is important to leave bit *dc* in the *Power Management Command* at its default state (0) otherwise there will be no clock signal on the CLK pin.

Switching between the fast and slow clock modes is glitch-free in a sense that either state of the clock lasts for at least a half cycle of the fast clock. During switching the clock can be logic low once for an intermediate period i.e. for any time between the half cycle of the fast and the slow clock.

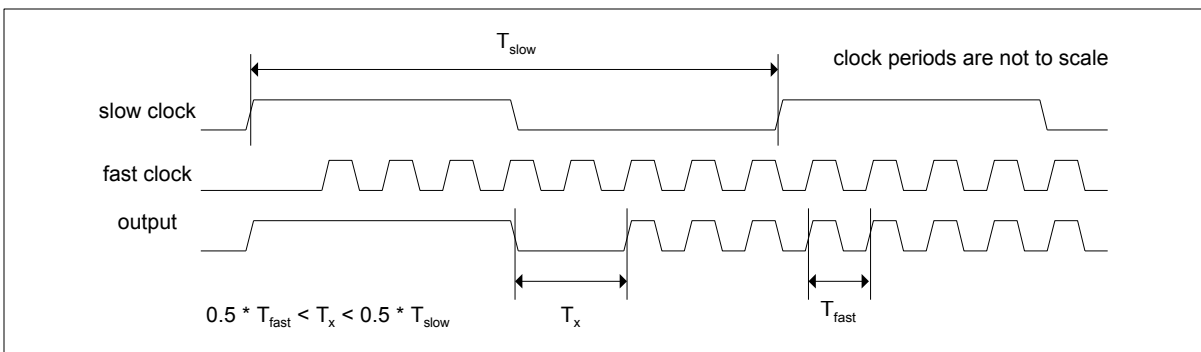

The clock switching synchronization circuit detects the falling edges of the clocks. One consequence is a latency of 0 to  $T_{slow} + T_{fast}$  from the occurrence of a clock change request (entering into sleep mode or interrupt) until the beginning of the intermediate length ( $T_x$ ) half cycle. The other is that both clocks should be up and running for the change to occur. Changing from fast to slow clock, it is automatically ensured by entering into the sleep mode in the appropriate way provided that the wake-up timer is continuously enabled. As the crystal oscillator is normally stopped while the slow clock is used, when changing back to fast clock the crystal oscillator startup time has to pass first before the above mentioned latency period starts. The startup condition is detected internally, so no software timing is necessary.

## Wake-Up Timer Calibration

By default the wake-up timer is calibrated each time it is enabled by setting the *et* bit in the *Power Management Command*. After timeout the timer can be stopped by resetting this bit otherwise it operates continuously. If the timer is programmed to run for longer periods, at approximately every 40 seconds it performs additional self-calibration.

This feature can be disabled to avoid sudden changes in the actual wake-up time period. A suitable software algorithm can then compensate for the gradual shift caused by temperature change.

Bit *dcal* in the *Extended Features Command* (page 14) controls the automatic calibration feature. It is reset to 0 at power-on and the automatic calibration is enabled. This is necessary to compensate for process tolerances. After one calibration cycle further (re)calibration can be disabled by setting this bit to 1.

## MATCHING NETWORK FOR A 50 OHM SINGLE ENDED OUTPUT

### Matching Network Schematic

|                 |     |
|-----------------|-----|
| $C_1, C_2$ [pF] | 3.9 |
| $L_1$ [nH]      | 6.8 |
| $L_3$ [nH]      | 100 |

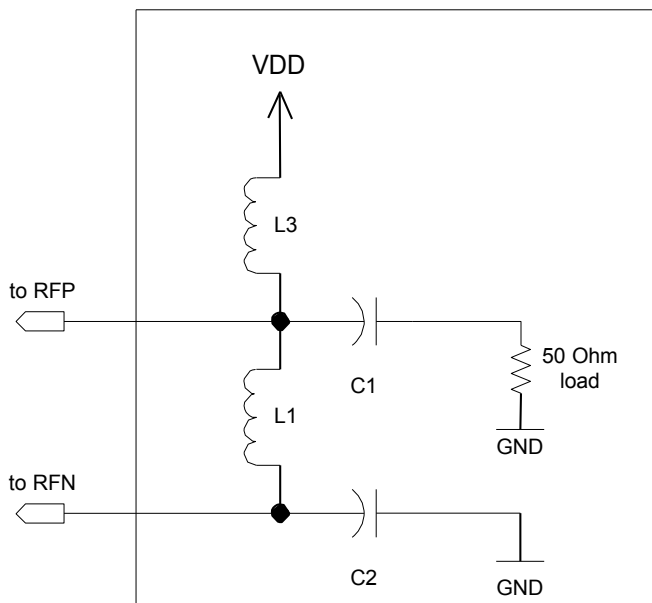

## RX-TX ALIGNMENT PROCEDURES

RX-TX frequency offset can be caused only by the differences in the actual reference frequency. To minimize these errors it is suggested to use the same crystal type and the same PCB layout for the crystal placement on the RX and TX PCBs.

To verify the possible RX-TX offset it is suggested to measure the CLK output of both chips with a high level of accuracy. Do not measure the output at the XTL pin since the measurement process itself will change the reference frequency. Since the carrier frequencies are derived from the reference frequency, having identical reference frequencies and nominal frequency settings at the TX and RX side there should be no offset if the CLK signals have identical frequencies.

It is possible to monitor the actual RX-TX offset using the AFC status report included in the status byte of the receiver. By reading out the status byte from the receiver the actual measured offset frequency will be reported. In order to get accurate values the AFC has to be disabled during the read by clearing the "en" bit in the AFC Control Command (bit 0).

**CRYSTAL SELECTION GUIDELINES**

The crystal oscillator of the Si4022 requires a 10 MHz parallel mode crystal. The circuit contains an integrated load capacitor in order to minimize the external component count. The internal load capacitance value is programmable from 8.5 pF to 16 pF in 0.5 pF steps. With appropriate PCB layout, the total load capacitance value can be 10 pF to 20 pF so a variety of crystal types can be used.

When the total load capacitance is not more than 20 pF and a worst case 7 pF shunt capacitance ( $C_o$ ) value is expected for the crystal, the oscillator is able to start up with any crystal having less than 300 ohms ESR (equivalent series loss resistance). However, lower  $C_o$  and ESR values guarantee faster oscillator startup. It is recommended to keep the PCB parasitic capacitances on the XTL pin as low as possible.

The crystal frequency is used as the reference of the PLL, which generates the RF carrier frequency ( $f_c$ ). Therefore  $f_c$  is directly proportional to the crystal frequency. The accuracy requirements for production tolerance, temperature drift and aging can thus be determined from the maximum allowable carrier frequency error.

**Maximum XTAL Tolerances Including Temperature and Aging [ppm]**

|                           |                                 |           |           |           |            |            |            |            |
|---------------------------|---------------------------------|-----------|-----------|-----------|------------|------------|------------|------------|
| <b>Bit Rate: 2.4 kbps</b> | Transmitter Deviation [+/- kHz] |           |           |           |            |            |            |            |
|                           | <b>20</b>                       | <b>40</b> | <b>60</b> | <b>80</b> | <b>100</b> | <b>120</b> | <b>140</b> | <b>160</b> |
|                           | <b>868</b>                      | 2         | 12        | 25        | 30         | 40         | 50         | 70         |
| <b>915</b>                | 2                               | 12        | 20        | 30        | 40         | 50         | 60         | 70         |

|                           |                                 |            |           |           |            |            |            |            |
|---------------------------|---------------------------------|------------|-----------|-----------|------------|------------|------------|------------|
| <b>Bit Rate: 9.6 kbps</b> | Transmitter Deviation [+/- kHz] |            |           |           |            |            |            |            |
|                           | <b>20</b>                       | <b>40</b>  | <b>60</b> | <b>80</b> | <b>100</b> | <b>120</b> | <b>140</b> | <b>160</b> |
|                           | <b>868</b>                      | do not use | 8         | 20        | 30         | 40         | 50         | 60         |
| <b>915</b>                | do not use                      | 8          | 15        | 30        | 40         | 50         | 60         | 70         |

|                            |                                 |            |            |           |            |            |            |            |
|----------------------------|---------------------------------|------------|------------|-----------|------------|------------|------------|------------|
| <b>Bit Rate: 38.4 kbps</b> | Transmitter Deviation [+/- kHz] |            |            |           |            |            |            |            |
|                            | <b>20</b>                       | <b>40</b>  | <b>60</b>  | <b>80</b> | <b>100</b> | <b>120</b> | <b>140</b> | <b>160</b> |
|                            | <b>868</b>                      | do not use | do not use | 10        | 20         | 30         | 40         | 50         |
| <b>915</b>                 | do not use                      | do not use | 10         | 20        | 30         | 40         | 50         | 60         |

|                             |                                 |            |            |            |            |            |            |            |
|-----------------------------|---------------------------------|------------|------------|------------|------------|------------|------------|------------|
| <b>Bit Rate: 115.2 kbps</b> | Transmitter Deviation [+/- kHz] |            |            |            |            |            |            |            |
|                             | <b>20</b>                       | <b>40</b>  | <b>60</b>  | <b>80</b>  | <b>100</b> | <b>120</b> | <b>140</b> | <b>160</b> |
|                             | <b>868</b>                      | do not use | do not use | do not use | do not use | do not use | 2          | 12         |
| <b>915</b>                  | do not use                      | do not use | do not use | do not use | do not use | 2          | 12         | 20         |

Whenever a low frequency error is essential for the application, it is possible to “pull” the crystal to the accurate frequency by changing the load capacitor value. The widest pulling range can be achieved if the nominal required load capacitance of the crystal is in the “midrange”, for example 16 pF. The “pull-ability” of the crystal is defined by its motional capacitance and  $C_o$ .

**Note:** There may be other requirements for the TX carrier accuracy with regards to the requirements as defined by standards and/or channel separations.



## EXAMPLE APPLICATIONS: DATA PACKET TRANSMISSION

### Data packet structure

An example data packet structure using the Si4022 – Si4022 pair for data transmission. This packet structure is an example of how to use the high efficiency FIFO mode at the receiver side:

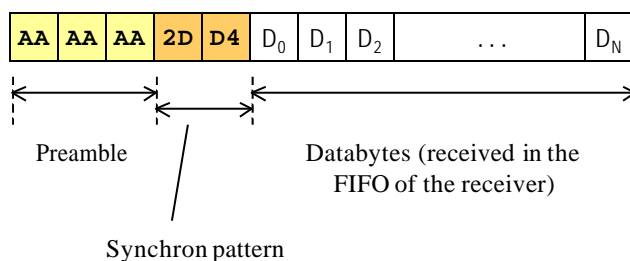

The first 3 bytes compose a 24 bit length '01' pattern to let enough time for the clock recovery of the receiver to lock. The next two bytes compose a 16 bit synchron pattern which is essential for the receiver's FIFO to find the byte synchron in the received bit stream. The synchron pattern is followed by the payload. The first byte transmitted after the synchron pattern ( $D_0$  in the picture above) will be the first received byte in the FIFO.

**Important:** The bytes of the data stream should follow each other continuously, otherwise the clock recovery circuit of the receiver side will be unable to track.

Further details of packet structures can be found in the IA ISM-UGSB1 software development kit manual.

**PACKAGE INFORMATION**

**16-pin TSSOP**

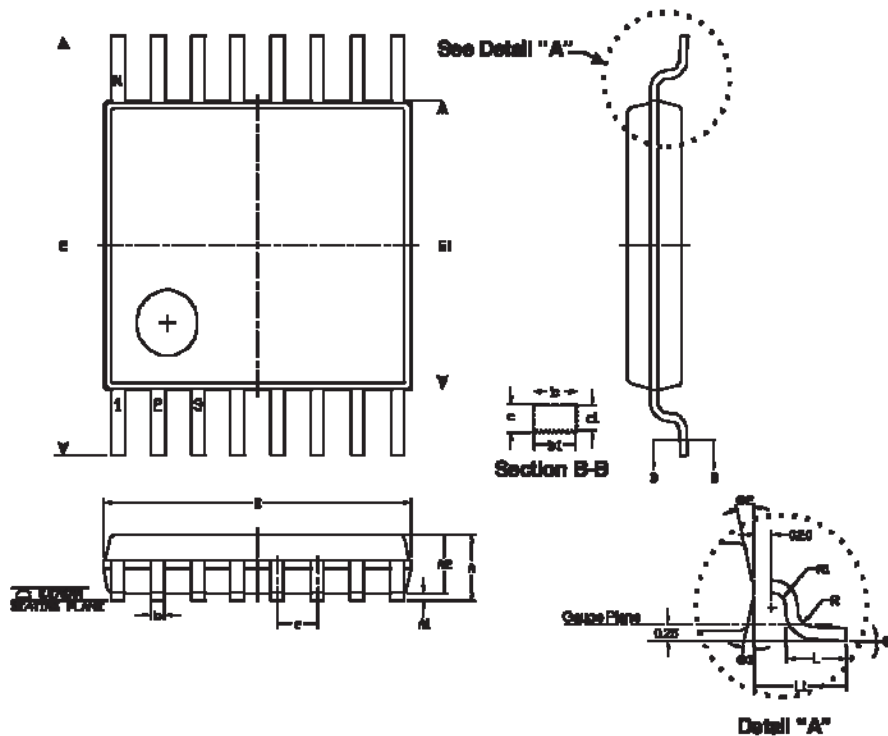

| Symbol | Dimensions in mm |      |      | Dimensions in inches |       |       |
|--------|------------------|------|------|----------------------|-------|-------|
|        | Min.             | Nom. | Max. | Min.                 | Nom.  | Max.  |
| A      |                  |      | 1,20 |                      |       | 0,047 |
| A1     | 0,05             |      | 0,15 | 0,002                |       | 0,006 |
| A2     | 0,80             | 0,90 | 1,05 | 0,031                | 0,035 | 0,041 |
| b      | 0,19             |      | 0,30 | 0,007                |       | 0,012 |
| b1     | 0,19             | 0,22 | 0,25 | 0,007                | 0,009 | 0,010 |
| c      | 0,09             |      | 0,20 | 0,004                |       | 0,008 |
| c1     | 0,09             |      | 0,16 | 0,004                |       | 0,006 |
| D      | 4,90             | 5,00 | 5,10 | 0,193                | 0,197 | 0,201 |
| e      | 0,65 BSC.        |      |      | 0,026 BSC.           |       |       |
| E      | 6,40 BSC.        |      |      | 0,252 BSC.           |       |       |
| E1     | 4,30             | 4,40 | 4,50 | 0,169                | 0,173 | 0,177 |
| L      | 0,50             | 0,60 | 0,75 | 0,020                | 0,024 | 0,030 |
| L1     | 1,00 REF.        |      |      | 0,39 REF.            |       |       |
| R      | 0,09             |      |      | 0,004                |       |       |
| R1     | 0,09             |      |      | 0,004                |       |       |
| θ1     | 0                |      | 8    | 0                    |       | 8     |
| θ2     | 12 REF.          |      |      | 12 REF.              |       |       |
| θ3     | 12 REF.          |      |      | 12 REF.              |       |       |

**ORDERING INFORMATION****Si4022 Universal ISM Band FSK Transmitter**

| DESCRIPTION                | ORDERING NUMBER                           |
|----------------------------|---|
| Si4022 16-pin TSSOP<br>die | Si4022-IC CC16 Rev A0<br>see Silicon Labs |

**Demo Boards and Development Kits**

| DESCRIPTION                 | ORDERING NUMBER |
|-----------------------------|-----------------|
| ISM Chipset Development Kit | IA ISM - DK3    |

**Related Resources**

| DESCRIPTION                            | ORDERING NUMBER   |
|--|---|
| Antenna Selection Guide                | IA ISM - AN1  |
| Antenna Development Guide              | IA ISM - AN2  |
| IA4322 Universal ISM Band FSK Receiver | see <a href="http://www.silabs.com/integration">http://www.silabs.com/integration</a> for details |

**Note: Volume orders must include chip revision to be accepted.**

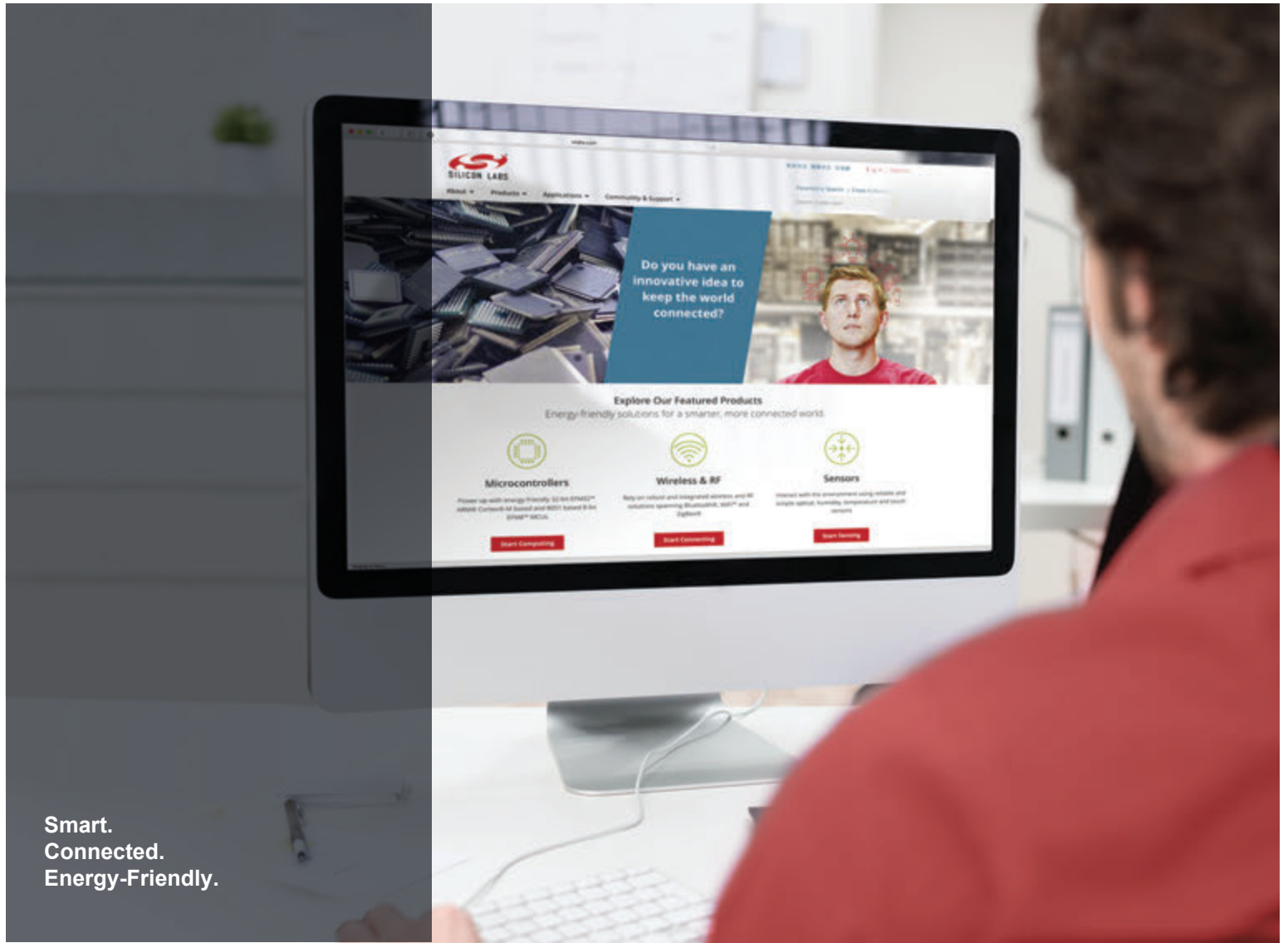

Smart.  
Connected.  
Energy-Friendly.



**Products**  
[www.silabs.com/products](http://www.silabs.com/products)

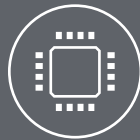

**Quality**  
[www.silabs.com/quality](http://www.silabs.com/quality)



**Support and Community**  
[community.silabs.com](http://community.silabs.com)

**Disclaimer**

Silicon Laboratories intends to provide customers with the latest, accurate, and in-depth documentation of all peripherals and modules available for system and software implementers using or intending to use the Silicon Laboratories products. Characterization data, available modules and peripherals, memory sizes and memory addresses refer to each specific device, and "Typical" parameters provided can and do vary in different applications. Application examples described herein are for illustrative purposes only. Silicon Laboratories reserves the right to make changes without further notice and limitation to product information, specifications, and descriptions herein, and does not give warranties as to the accuracy or completeness of the included information. Silicon Laboratories shall have no liability for the consequences of use of the information supplied herein. This document does not imply or express copyright licenses granted hereunder to design or fabricate any integrated circuits. The products are not designed or authorized to be used within any Life Support System without the specific written consent of Silicon Laboratories. A "Life Support System" is any product or system intended to support or sustain life and/or health, which, if it fails, can be reasonably expected to result in significant personal injury or death. Silicon Laboratories products are not designed or authorized for military applications. Silicon Laboratories products shall under no circumstances be used in weapons of mass destruction including (but not limited to) nuclear, biological or chemical weapons, or missiles capable of delivering such weapons.

**Trademark Information**

Silicon Laboratories Inc.®, Silicon Laboratories®, Silicon Labs®, SiLabs® and the Silicon Labs logo®, Bluegiga®, Bluegiga Logo®, Clockbuilder®, CMEMS®, DSPLL®, EFM®, EFM32®, EFR®, Ember®, Energy Micro, Energy Micro logo and combinations thereof, "the world's most energy friendly microcontrollers", Ember®, EZLink®, EZRadio®, EZRadioPRO®, Gecko®, ISOModem®, Precision32®, ProSLIC®, Simplicity Studio®, SiPHY®, Telegesis, the Telegesis Logo®, USBXpress® and others are trademarks or registered trademarks of Silicon Laboratories Inc. ARM, CORTEX, Cortex-M3 and THUMB are trademarks or registered trademarks of ARM Holdings. Keil is a registered trademark of ARM Limited. All other products or brand names mentioned herein are trademarks of their respective holders.



Silicon Laboratories Inc.  
400 West Cesar Chavez  
Austin, TX 78701  
USA

<http://www.silabs.com>

## Looking for pricing, stock, or lifecycle information?

Click below to explore more details on WIN SOURCE:

 [View SI4022-A1-FT on WIN SOURCE](#)

 [Silicon Labs](#) Information

## Optimize Your Supply Chain with WIN SOURCE Solutions

-  Global Sourcing Solution
-  Obsolete Management
-  Cost Control Management
-  Shortage Management
-  Alternative Solution
-  Excess Inventory Management