

**Integrated Photo Detector Receiver for Plastic Fiber
Plastic Connector Housing**

**SFH551/1-1
SFH551/1-1V**

Features

- Bipolar IC with open-collector output
- Digital output, TTL compatible
- Sensitive in visible and near IR range
- Low switching threshold
- Transfer rate ≤ 5 Mbit/s
- 2.2 mm aperture holds standard 1000 micron plastic fiber
- No fiber stripping required
- Molded microlens for efficient coupling

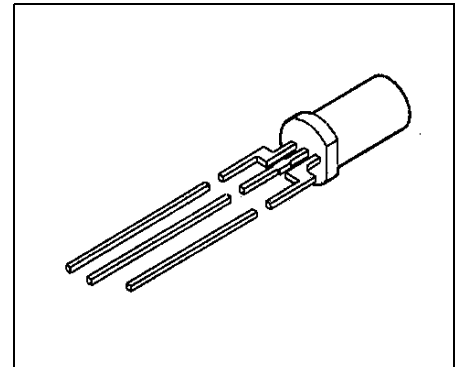

Plastic Connector Housing

- Mounting screw attached to the connector
- Interference-free transmission from light-tight housing
- Transmitter and receiver can be flexibly positioned
- No cross talk
- Auto insertable and wave solderable
- Supplied in tubes

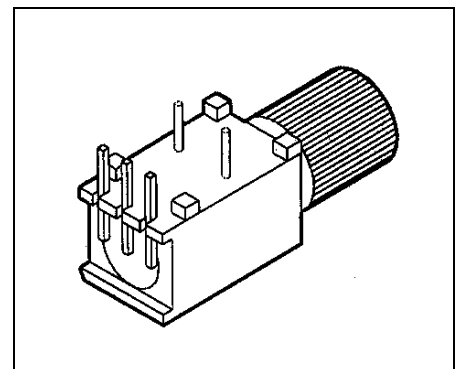

Applications

- Household electronics
- Power electronics
- Optical networks

Type	Ordering Code
SFH551/1-1	Q62702-P3180
SFH551/1-1V	Q62702-P3181

Block Diagram

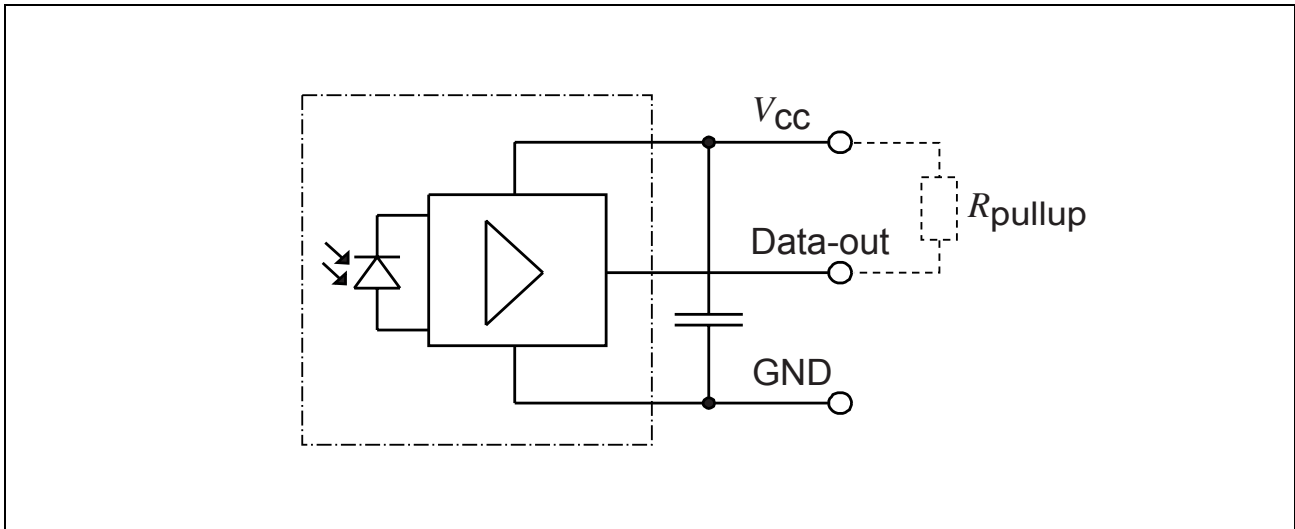

Figure 1

A bypass capacitor (100 nF) near the device (distance ≤ 3 cm) is necessary between ground and V_{CC} . In critical applications the distance may be shorter.

Description

The SFH551/1V is a transimpedance amplifier with digital TTL open collector output stage and integrated photodiode. The active area of the detector in connection with the molded microlens gives an efficient coupling from the end of a plastic fiber.

The receiver is fully DC coupled and therefore no line code is needed.

The SFH551/1V includes a Schmitt trigger function to provide stable output states over the whole dynamic range. For optical input power levels above $6 \mu\text{W}$ typically the electrical output will be logical "low" and vice versa. With noise free V_{CC} and GND no undefined output signal is possible. SFH551/1 must not be used without shielding the ambient light, because ambient light causes malfunction when reaching the threshold level, noise or complete switching the output. Interference free transmission is possible by using the SFH551/1V with the black plastic connector housing.

Technical Data
Absolute Maximum Ratings

Parameter	Symbol	Limit Values		Unit
		min.	max.	
Operating Temperature Range	T_{OP}	-40	+85	°C
Storage Temperature Range	T_{STG}	-40	+100	°C
Soldering Temperature (2 mm from case bottom, $t \leq 5$ s)	T_S		260	°C
Supply Voltage Range without Damage	V_{CC}	-0.5	15	V
Recommended and Guaranteed Maximum Voltage			5.5	V
Minimum Supply Voltage for Function	V_{CCmin}	4		V
Minimum Pull-up Resistance ($V_{CC} = 5$ V)	R_{outmin}	330		Ω
Output Voltage	V_O	-0.5	15	V
Output Current	I_O		50	mA
Power Dissipation (output)	P_O		100	mW

Characteristics ($T_A = 25^\circ\text{C}$, $V_{CC} = 4.75$ to 5.25 V)

Parameter	Symbol	Values			Unit
		min.	typ.	max.	
Maximum Photosensitivity Wavelength	$\lambda_{S_{max}}$		700		nm
Photosensitivity Spectral Range ($S = 80\% S_{max}$)	λ	600		780	nm
SFH551/1-1 Optical Threshold Power ($\lambda = 660$ nm) for Output Low	Φ_{INth}		≥ 6 ≥ -22		μW dBm
Maximum Optical Power ($\lambda = 660$ nm) Maximum Value of t_{PLH} at Maximum Power	Φ_{INL}		1000 0		μW dBm
Optical Power for Output High without Errors ($\lambda = 660$ nm)	Φ_{INH}		≤ 0.1 ≤ -40		μW dBm
Propagation Delay (optical input to electrical output, with fast optical pulse)	t_{PHL} t_{PLH}		< 100 < 250		ns
Current Consumption (without output current)	I_{CC}		4		mA

Package Outlines

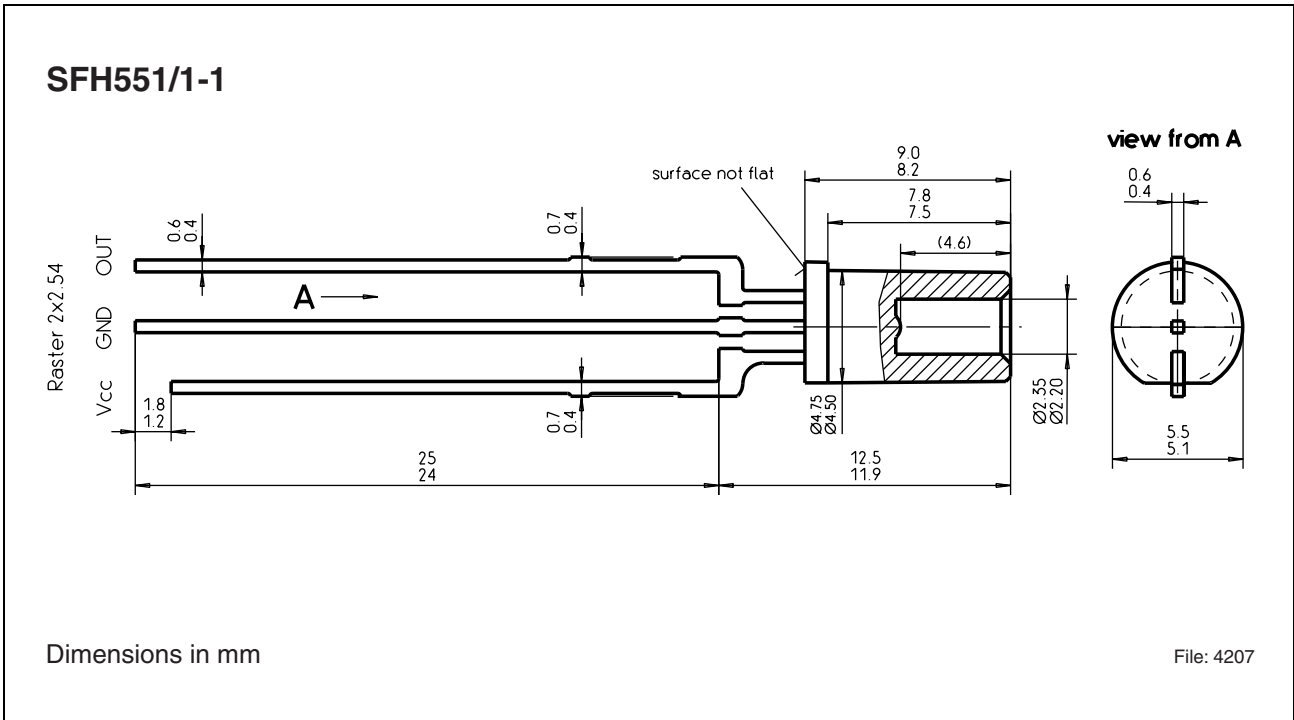

Figure 2

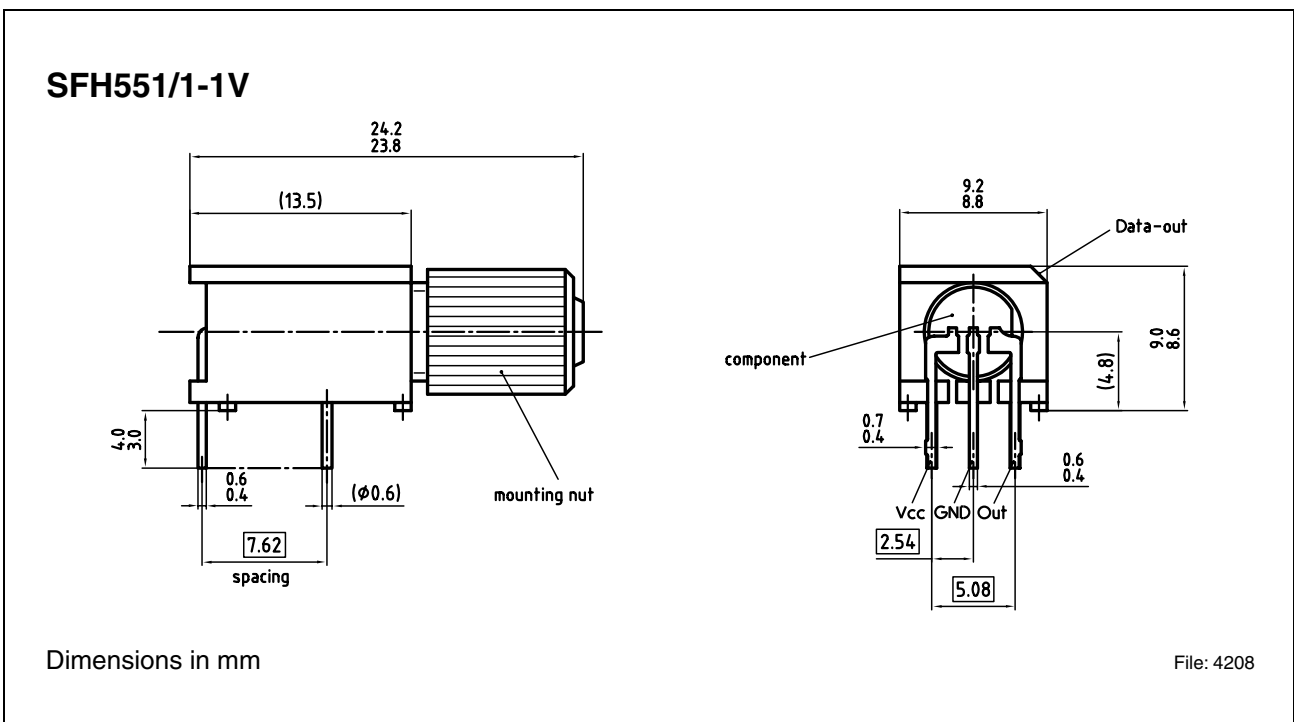

Figure 3

SFH551/1-1
SFH551/1-1V

Revision History: **2005-06-09**

DS2

Previous Version: 2004-03-19

Edition 2005-06-09

**Published by Infineon Technologies AG,
St.-Martin-Strasse 53,
81669 München, Germany**

**© Infineon Technologies AG 2005.
All Rights Reserved.**

Attention please!

The information herein is given to describe certain components and shall not be considered as a guarantee of characteristics.

Terms of delivery and rights to technical change reserved.

We hereby disclaim any and all warranties, including but not limited to warranties of non-infringement, regarding circuits, descriptions and charts stated herein.

Information

For further information on technology, delivery terms and conditions and prices please contact your nearest Infineon Technologies Office (www.infineon.com).

Warnings

Due to technical requirements components may contain dangerous substances. For information on the types in question please contact your nearest Infineon Technologies Office.

Infineon Technologies Components may only be used in life-support devices or systems with the express written approval of Infineon Technologies, if a failure of such components can reasonably be expected to cause the failure of that life-support device or system, or to affect the safety or effectiveness of that device or system. Life support devices or systems are intended to be implanted in the human body, or to support and/or maintain and sustain and/or protect human life. If they fail, it is reasonable to assume that the health of the user or other persons may be endangered.

Looking for pricing, stock, or lifecycle information?

Click below to explore more details on WIN SOURCE:

- ⊖ [View SFH 551/1V-1 on WIN SOURCE](#)
- ⊖ [Infineon Technologies Information](#)

Optimize Your Supply Chain with WIN SOURCE Solutions

- ✓ Global Sourcing Solution
- ✓ Obsolete Management
- ✓ Cost Control Management
- ✓ Shortage Management
- ✓ Alternative Solution
- ✓ Excess Inventory Management