



**THE DATASHEET OF
SDP8314-301**



SDP8304/8314

Optoschmitt Detector Open-Collector Output

FEATURES

- Side-looking plastic package
- 55° (nominal) acceptance angle
- TTL/LSTTL/CMOS compatible
- Open collector output
- Buffer (SDP8304) or inverting (SDP8314) logic available
- High noise immunity output
- Mechanically and spectrally matched to SEP8506 and SEP8706 infrared emitting diodes

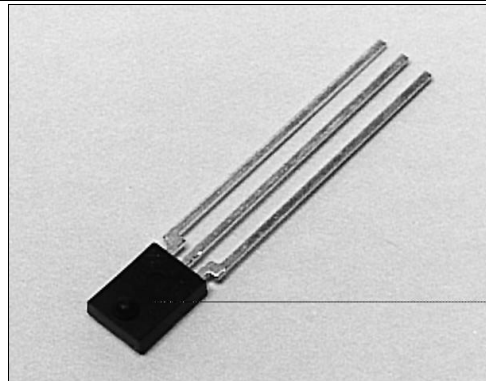

INFRA-8.TIF

DESCRIPTION

The SDP8304/8314 series consists of a high speed IC molded in a side-looking black plastic package to minimize the effect of visible ambient light. The detector incorporates a Schmitt trigger which provides pulse shaping and hysteresis for noise immunity. Output rise and fall times are independent of rate of change of incident light. Detector sensitivity has been internally temperature compensated. The output stage is an open collector NPN transistor. This configuration allows the sensor to interface with circuit elements driven by supply voltages other than the V_{CC} supply. For additional output configuration options refer to SDP8004/8014 and SDP8604/8614.

Device Polarity:

- Buffer - Output is HI when incident light intensity is above the turn- on threshold level.
- Inverter - Output is LO when incident light intensity is above the turn- on threshold level.

OUTLINE DIMENSIONS in inches (mm)

Tolerance	3 plc decimals	$\pm 0.005(0.12)$
	2 plc decimals	$\pm 0.020(0.51)$

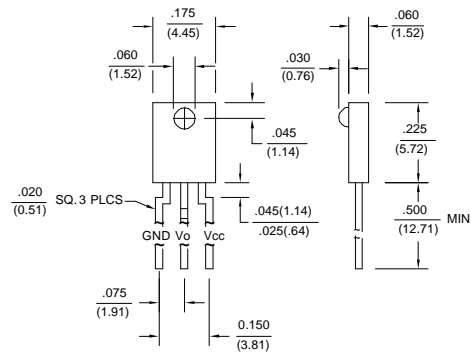

DIM_026.ds4

SDP8304/8314

Optoschmitt Detector Open-Collector Output

ELECTRICAL CHARACTERISTICS (-40°C to +85°C unless otherwise noted)

PARAMETER	SYMBOL	MIN	TYP	MAX	UNITS	TEST CONDITIONS
Operating Supply Voltage	V_{CC}	4.5	12.0		V	$T_A=25^\circ\text{C}$
Turn-on Threshold Irradiance ⁽²⁾ SDP8304-301, SDP8314-301	$E_{ET(+)}$	0.06	0.37		mW/cm ²	$V_{CC}=5\text{ V}$ $T_A=25^\circ\text{C}$
Hysteresis ⁽³⁾	HYST	33	67		%	
Supply Current	I_{CC}			15.0	mA	$V_{CC}=12\text{ V}$ $E_e=0$ Or 3.0 mW/cm ²
Low Level Output Voltage SDP8304 SDP8314	V_{OL}			0.4 0.4	V	$V_{CC}=5\text{ V}$, $I_{OL}=12.8\text{ mA}$ $E_e=0$ $E_e=3.0\text{ mW/cm}^2$
High Level Output Current SDP8304 SDP8314	I_{OH}			100 100	μA	$V_{CC}=4.5\text{ V}$ $V_{OH}=30\text{ V}$ $E_e=3.0\text{ mW/cm}^2$ $E_e=0$
Operate Point Temperature Coefficient			-0.76		%/°C	Emitter @ Constant Temperature
Output Rise Time, Output Fall Time	t_r , t_f		7.0		ns	$V_{CC}=5\text{ V}$, $T_A=25^\circ\text{C}$ $E_e=0$ or 3.0 mW/cm ² $f=10.0\text{ kHz}$, D.C.=50% $R_L=390\ \Omega$
Propagation Delay, Low-High, High-Low	t_{PLH} , t_{PHL}		2.5	5.0	μs	$V_{CC}=5\text{ V}$, $T_A=25^\circ\text{C}$ $E_e=0.5\text{ mW/cm}^2$ $f=10.0\text{ kHz}$, D.C.=50% $R_L=390\ \Omega$
Clock Frequency				100	kHz	$R_L=390\ \Omega$, $C_L=50\text{ pF}$

Notes

- It is recommended that a bypass capacitor, 0.1 μF typical, be added between V_{CC} and GND near the device in order to stabilize power supply line.
- The radiation source is an IRED with a peak wavelength of 935 nm.
- Hysteresis is defined as the difference between the operating and release threshold intensities, expressed as a percentage of the operate threshold intensity.

ABSOLUTE MAXIMUM RATINGS

(25°C Free-Air Temperature unless otherwise noted)

Supply Voltage	12 V ⁽¹⁾
Duration of Output	1.0 sec
Short to V_{CC} or Ground	1.0 sec
Applied Output Voltage	35 V
Low Level Output Current	16 mA
Irradiance	25 mW/cm ²
Operating Temperature Range	-40°C to 85°C
Storage Temperature Range	-40°C to 85°C
Soldering Temperature (5 sec)	240°C

Notes

- Derate linearly from 25°C to 5.5 V at 85°C.

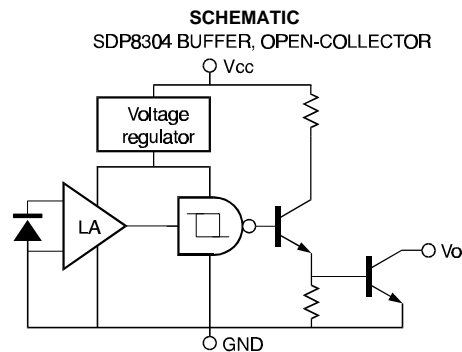

Honeywell reserves the right to make changes in order to improve design and supply the best products possible.

Honeywell

SDP8304/8314

Optoschmitt Detector
Open-Collector Output

SCHEMATIC

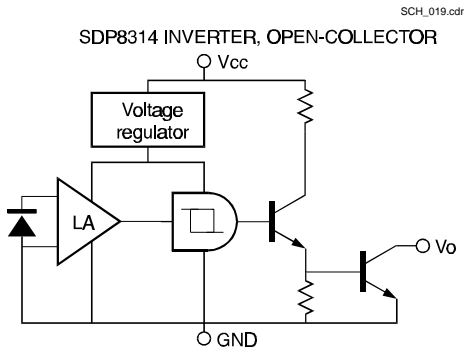

SWITCHING TIME TEST CIRCUIT

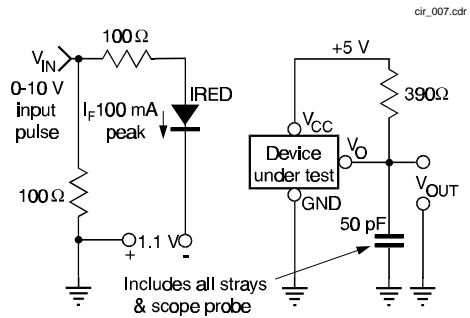

SWITCHING WAVEFORM FOR BUFFERS

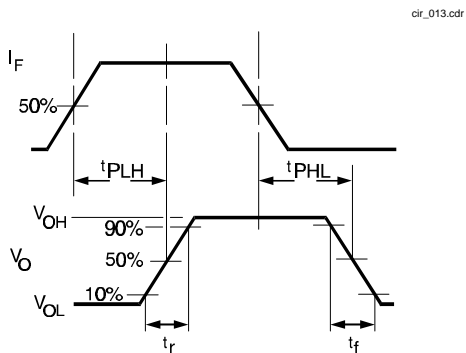
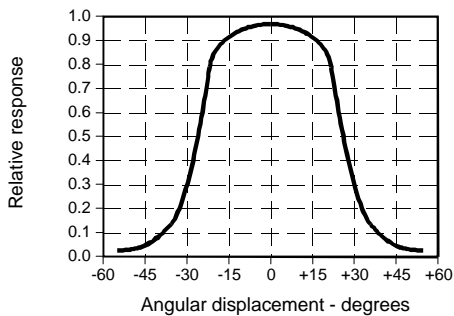

Fig. 1 Responsivity vs Angular Displacement



SWITCHING WAVEFORM FOR INVERTERS

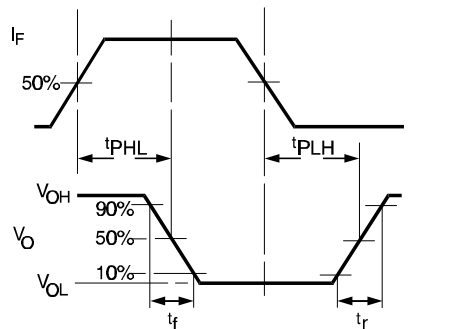
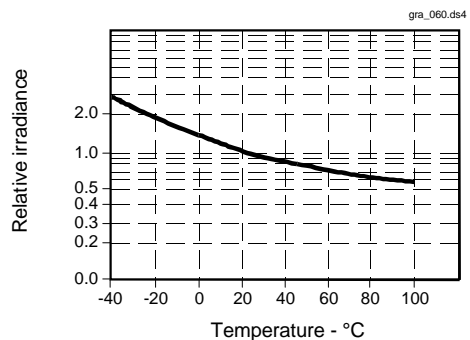

Fig. 2 Threshold Irradiance vs Temperature



SDP8304/8314

Optoschmitt Detector Open-Collector Output

Fig. 3 Output Rise Time (t_r) and Output Fall Time (t_f) vs Temperature gra_061.ds4

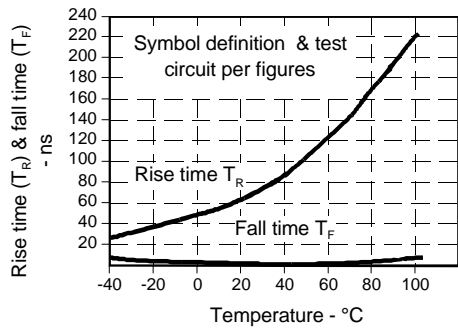

Fig. 4 Delay Time vs Temperature gra_062.ds4

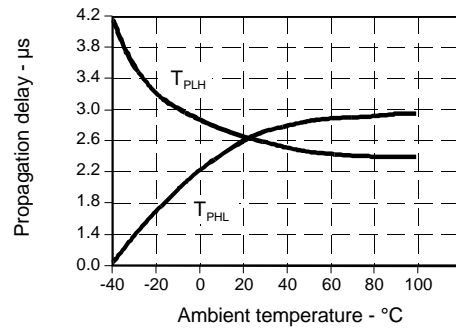
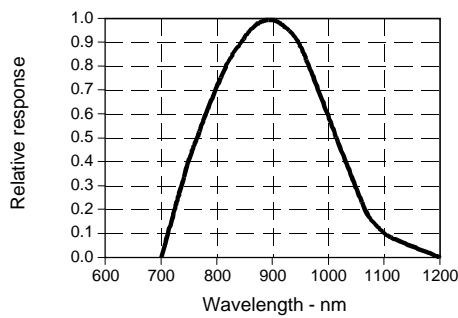



Fig. 5 Spectral Responsivity gra_050.ds4



All Performance Curves Show Typical Values

Looking for pricing, stock, or lifecycle information?

Click below to explore more details on WIN SOURCE:

-  [View SDP8314-301 on WIN SOURCE](#)
-  [Honeywell Information](#)

Optimize Your Supply Chain with WIN SOURCE Solutions

-  Global Sourcing Solution
-  Obsolete Management
-  Cost Control Management
-  Shortage Management
-  Alternative Solution
-  Excess Inventory Management