

**TS2 C 7 M 26 B - K**

TS2 Series

Connector Type:  
C - Cable-End

Options:  
K - Kit Packaging (one unit/bag)  
[blank] - Bulk Packaging  
Consult factory for other options

# of contacts:  
2-5 for #20  
6-9 for #26

Gender:  
M - Male (Pin)  
F - Female (Socket)

Clamp Set per Cable O.D. Range for Cable-End and Cable-to-Cable only:  
A - 0.110 - 0.140 [2.8 - 3.6]  
B - 0.140 - 0.180 [3.6 - 4.6]  
C - 0.180 - 0.216 [4.6 - 5.5]

Contact Size:  
20 - 20, 22, 24, 26 AWG wires  
26 - 26, 28, 30 AWG wires

Refer to TS2P SERIES drawing for mating Panel-mount connectors.  
Refer to TS2L SERIES drawing for mating Cable-to-Cable connectors.

SPECIFICATIONS:	
<b>MECHANICAL</b>	
Mating / Locking Type:	Threaded Coupling
Life	5,000 cycles minimum
Operating Forces	10 lb. [44.5 N] maximum Insertion or Withdrawal
Vibration	Mil-Std 202G Method 201A
Panel-Mount Hex Nut Tongue	40 in-lb [4.5 Nm] maximum
Cable Securing System:	Threaded on metal Clamp
<b>ELECTRICAL</b>	
Voltage Rating	125 V AC/DC for 2-5 contact arrangements 30 V AC/DC for 6-9 contact arrangements
Current Rating	Refer to Current Carry Capacity Table
Insulation Resistance	1000 MΩ minimum
Contact Resistance	10 mΩ typical
EMI Shielding	360°
<b>ENVIRONMENTAL</b>	
Temperature Limits	-40°C to +135°C (-40°F to +275°F)
Operating Temperature Range	Refer to Current Carry Capacity Table
Moisture Resistance	Mil-Std 202G Method 106G
Insulation Resistance	Mil-Std 202G Method 302
Thermal Shock	Mil-Std 202G Method 107G
Salt Atmosphere (Corrosion)	Mil-Std 202G Method 101E
Ingress Protection Ratings	IP66, IP67, IP68 (6 ft. for 24 hours) per IEC60529, NEMA 250 6P
<b>MATERIAL</b>	
Outer Shell Metal components	Copper Alloy, electroless nickel plated
Hex Nut & Inner Metal components	Copper Alloy, nickel plated
Electrical Insulator	Medical Technology LCP, natural
Seal O-rings	Thermoplastic Elastomer
Contacts Assembly	Copper Alloy, gold plated with Stainless Steel locking clip

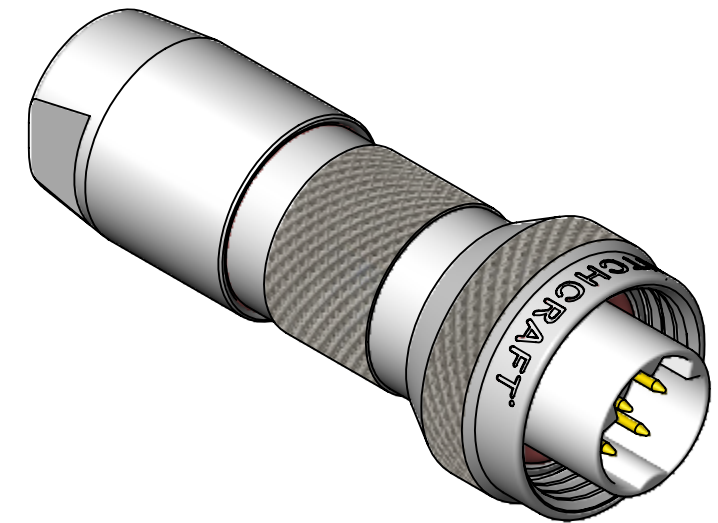

TYPICAL CABLE-END PIN (MALE)  
(TS2C7M26B SHOWN HERE)

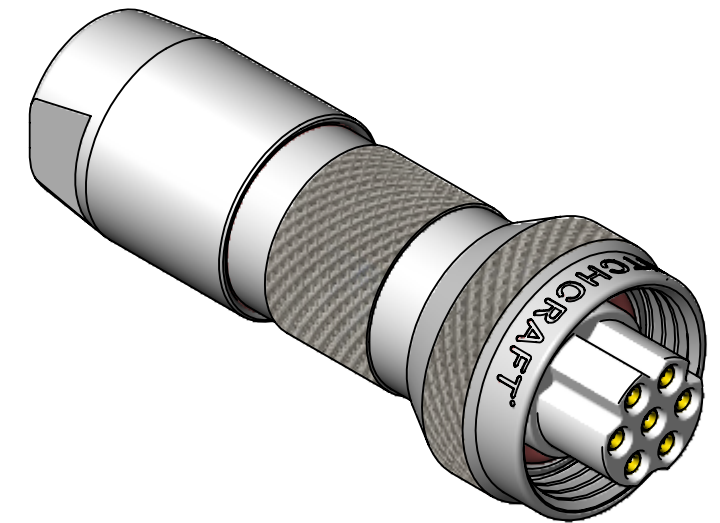

TYPICAL CABLE-END SOCKET (FEMALE)  
(TS2C7F26B SHOWN HERE)

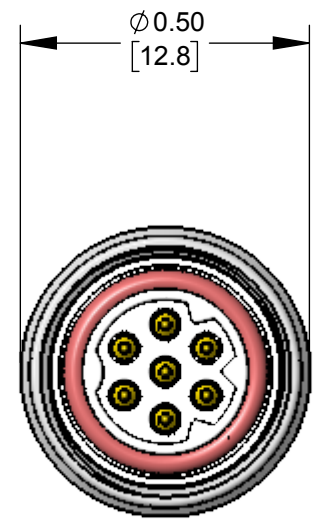

TS2C7M26B SHOWN HERE

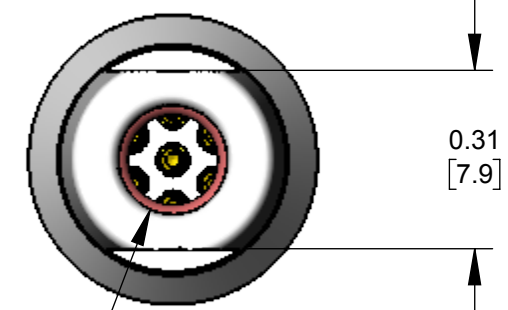
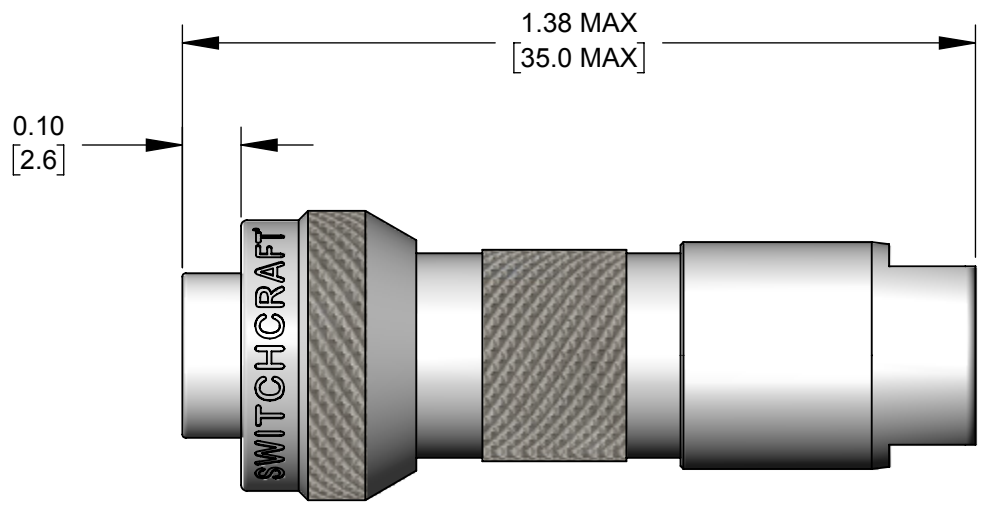

BACK NUT DIA.  
SIZE A: 0.150 [3.81] DIA.  
SIZE B: 0.190 [4.83] DIA.  
SIZE C: 0.230 [5.84] DIA.

ALL DIMENSIONS FOR REFERENCE ONLY

Contacts	Wire (awg)	Current Rating (A) at Operating Temperature (°C)					Minimum Test Voltage (V rms)	Voltage (V rms) tested per UL2238
		45°C max.	65°C max.	85°C max.	100°C max.	110°C max.		
2 #20	20	10	9	8	7*	6	1300	125
	22	8.5	7.5	7.5	5.5*	4.5		
	24	7	6	5	4.5*	3.5		
	26	4	4	3.5	3.5*	2.5		
3 #20	20	9.5	8.5	7.5	6.5*	5		
	22	8	7	6	5*	4		
	24	6	5.5	4.5	4*	3		
	26	3.5	3.5	3	3*	2.5		
4 #20	20	9	8	7	6*	5		
	22	7.5	6.5	5.5	4.5*	3.5		
	24	5	4.5	4	3.5*	2.5		
	26	3	3	2.5	2.5*	2		
5 #20	20	8	7.5	6.5	5.5*	4.5		
	22	6.5	5.5	5	4*	3		
	24	4.5	4	3.5	3*	2.5		
	26	2.5	2.5	2	2*	1.5		
6-7 #26	26	2.5	2.5	2	2*	1.5		
	28	2	2	1.5	1.5*	1		
	30	1.5	1.5	1	1*	.5		
	26	2	2	1.5	1.5*	1		
8-9 #26	28	1.5	1.5	1	1*	.5		
	30	1	1	.5	.5*	.5		

\*Temperature Rise does not exceed 30°C when tested according to UL2238. All other recommended current ratings are based on the Relative Thermal Index of the insulating material.

TOOL	TOOL TYPE	POSITIONER	CONTACT SIZE	WIRE SIZES
EN3CR	HAND CRIMP TOOL	EN2POS20	20 and 22	20 and 22 AWG
EN3CRAUTO	PNEUMATIC CRIMP TOOL	EN3POS26	26	26, 28, and 30 AWG
		EN2POS20	20 and 22	20 and 22 AWG
EN2CRL	HAND CRIMP TOOL LARGE FRAME	EN3POS26	26	26, 28, and 30 AWG
		EN2POS20L	20 and 22	20, 22, 24, and 26 AWG
INSTOOL20	CONTACT INSERTION	--	20	20, 22, 24, and 26 AWG
INSTOOL26	CONTACT INSERTION	--	26	26, 28, and 30 AWG
REMTOOL20	CONTACT EXTRACTION	--	20	20, 22, 24, and 26 AWG
REMTOOL26	CONTACT EXTRACTION	--	26	26, 28, and 30 AWG

REV	ECO NUMBER	DATE	BY	APVD
OB	10 lb WAS 5 lb	09/22/16	PNK	SRC
OA	PRELIMINARY	04/19/16	PNK	SRC

UNLESS OTHERWISE SPECIFIED

1. ALL DIMENSIONS IN INCHES [mm]  
- TWO PLACE DECIMALS ±0.02 [0.5]  
- THREE PLACE DECIMALS ±0.005 [0.13]

THIS DRAWING DESCRIBES A DESIGN CONSIDERED PROPRIETARY IN NATURE, DEVELOPED AND MANUFACTURED BY SWITCHCRAFT INC. AND IS RELEASED ON A CONFIDENTIAL BASIS FOR IDENTIFICATION PURPOSES ONLY.

SIZE	WIDTH	MULT	LBS/M	TEMPER
FINISH	FIRST USED ON		SCALE	
SPEC No.			3:1	
DATE DRAWN	BY	CHKD	APVD	
04/19/16	PNK	04/19/16	04/19/16	
NAME			PART No.	
CABLE-END			TS2C SERIES	
TS2 SERIES CONNECTOR			REV 0B	

DO NOT SCALE DRAWING

SolidWorks CAD File

CUSTOMER DRAWING



STEP 1

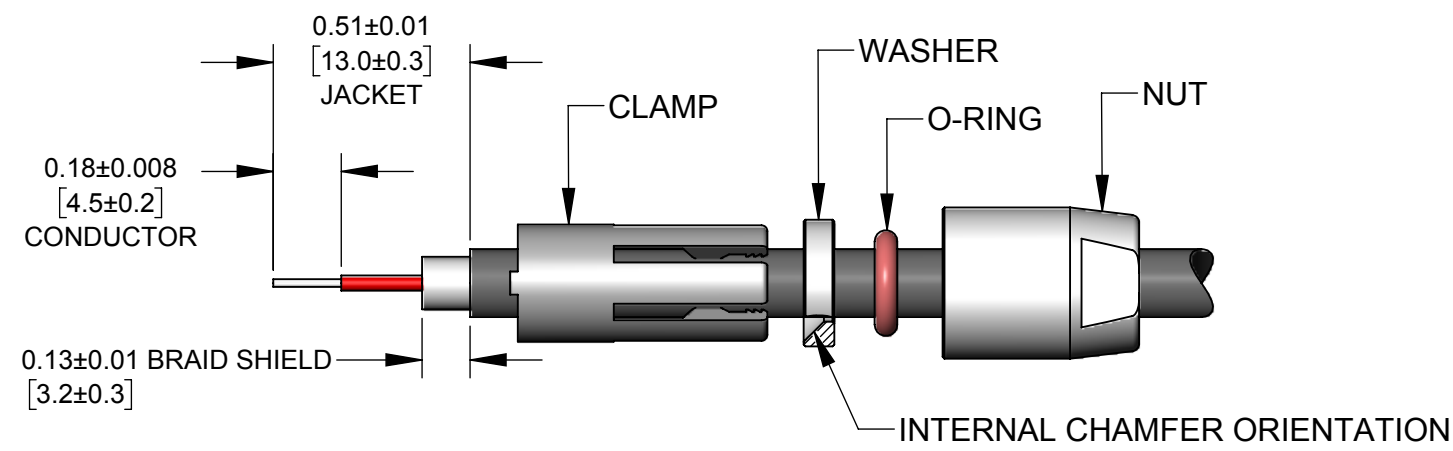

FEED THE FREE END OF CABLE THROUGH THE NUT, O-RING, WASHER, AND CLAMP IN THE ORDER SHOWN.  
STRIP THE CABLE JACKET, THE CONDUCTORS, AND THE CABLE SHIELDING AS SHOWN.

STEP 2

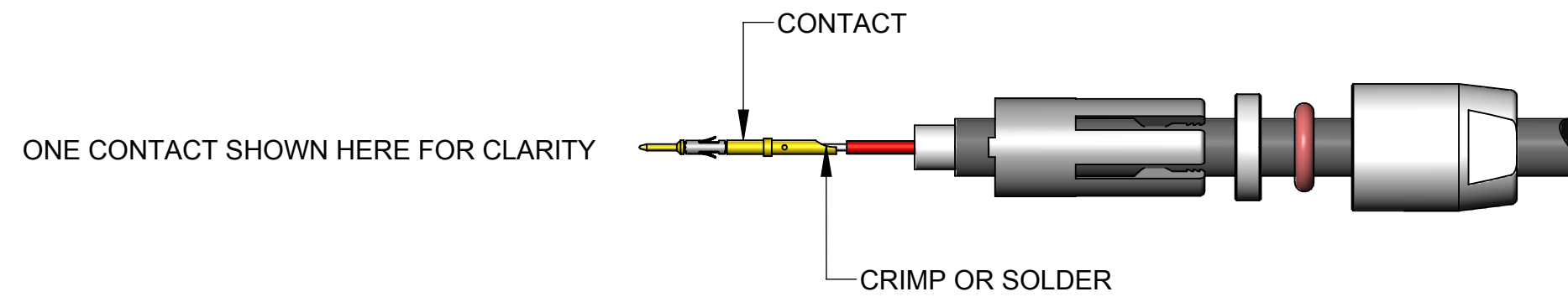

CRIMP CONDUCTORS TO CONTACTS USING HAND OR PNEUMATIC CRIMP TOOL\* WITH CRIMP POSITIONER\* SET PER CONTACT SIZE AND WIRE GAGE.  
IF SOLDERING, IT IS RECOMMENDED TO SOLDER CONDUCTORS TO CONTACTS BEFORE INSTALLATION.

STEP 3

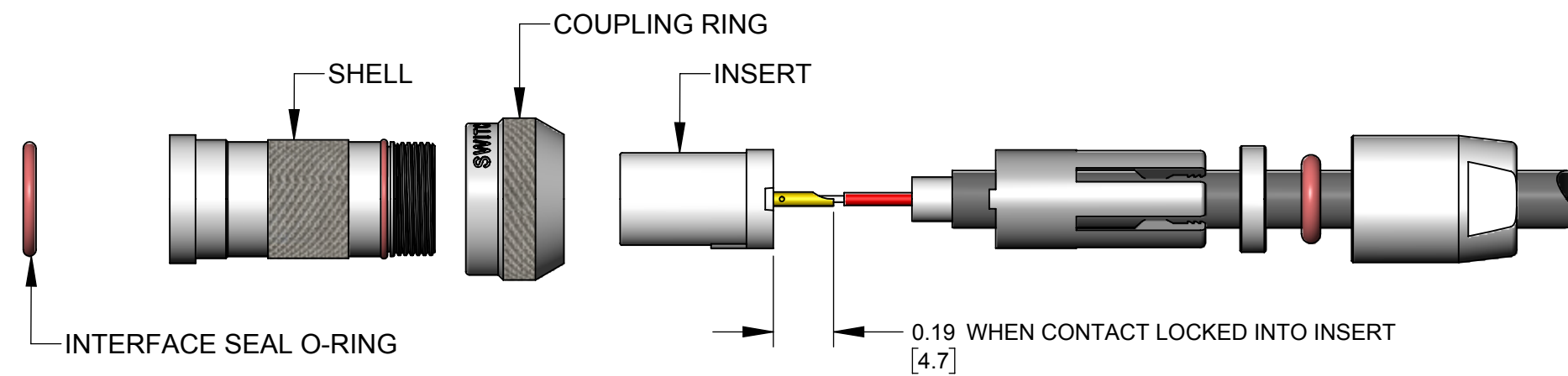

GUIDE EACH WIRED CONTACT INTO INSERT HOLE AND PUSH UNTIL CONTACT SNAPS IN PLACE. USE INSERTION TOOL\* IF NECESSARY.  
COLORED CONDUCTORS CAN BE ASSIGNED TO CONTACT POSITION NUMBERS AS DESIRED.  
TO REMOVE A CONTACT, INSERT THE EXTRACTION TOOL\* FROM THE FRONT OF INSERT AND LIGHTLY PRESS THE SPRING LOADED PLUNGER INWARD TO PUSH THE CONTACT OUT.

STEP 4

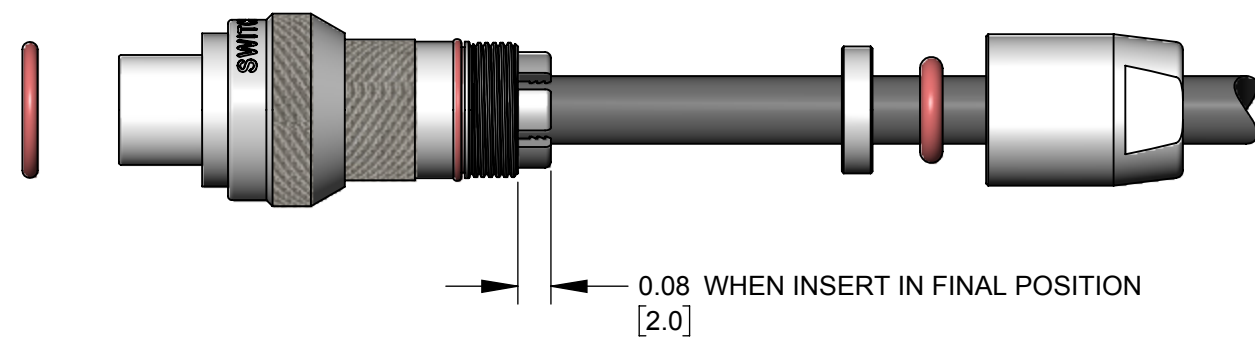

SLIDE COUPLING RING OVER SHELL ORIENTED AS SHOWN.  
ALIGN INSERT ASSEMBLY INTO SHELL FOLLOWED BY THE CLAMP. PUSH CLAMP LIGHTLY FORWARD AND ROTATE UNTIL THE ASSEMBLY SNAPS IN THE FINAL POSITION SHOWN.

STEP 5

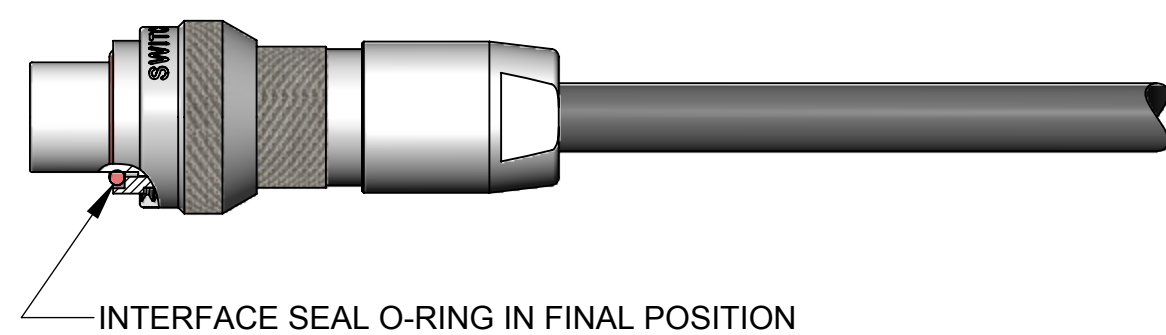

SLIDE WASHER, O-RING, AND NUT AGAINST CLAMP AND THREAD NUT ON UNTIL TIGHT - NOT TO EXCEED 9 IN-LB [1 Nm] TORQUE. A 5/16" [8mm] WRENCH CAN BE USED, IF NECESSARY.  
GUIDE THE INTERFACE SEAL O-RING OVER THE INSERT AND PUSH INTO THE GROOVE OF THE SHELL.

STEP 6

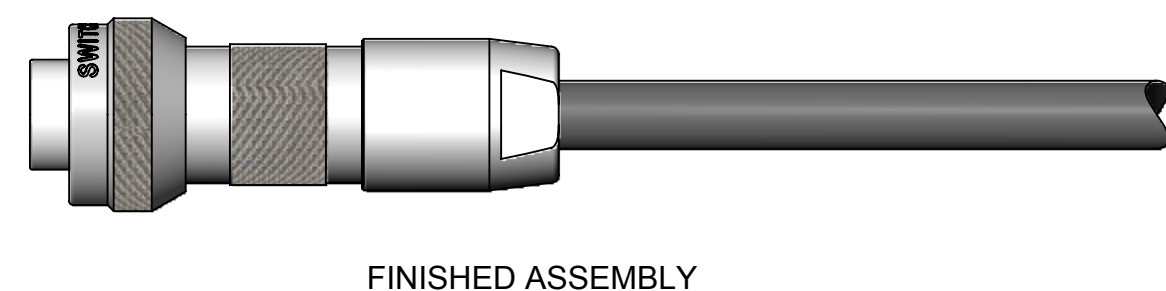

\*REFER TO TOOLS TABLE ON THIS DRAWING FOR SELECTION OF TOOLS PER CONTACT AND WIRE SIZE.

## TS2 SERIES CABLE-END FIELD ASSEMBLY INSTRUCTIONS

SCALE 2:1	Switchcraft®	
DATE DRAWN 04/19/16		
DRAWN BY PNK	PART No. TS2C SERIES_CD	REV 0A

Looking for pricing, stock, or lifecycle information?

Click below to explore more details on WIN SOURCE:

 [View TS2C7F26C on WIN SOURCE](#)

 [Switchcraft Inc. Information](#)

### Optimize Your Supply Chain with WIN SOURCE Solutions

-  Global Sourcing Solution
-  Obsolete Management
-  Cost Control Management
-  Shortage Management
-  Alternative Solution
-  Excess Inventory Management