



THE DATASHEET OF STEVAL-ISA101V1



2.5 A switch step down switching regulator

Features

- 2.5 A internal switch
- Operating input voltage from 4 V to 36 V
- 3.3 V / ($\pm 2\%$) reference voltage
- Output voltage adjustable from 1.235 V to 35 V
- Low dropout operation: 100 % duty cycle
- 250 kHz internally fixed frequency
- Voltage feedforward
- Zero load current operation
- Internal current limiting
- Inhibit for zero current consumption
- Synchronization
- Protection against feedback disconnection
- Thermal shutdown

Applications

- Consumer: STB, DVD, TV, VCR, car radio, LCD monitors
- Networking: XDSL, modems, DC-DC modules
- Computer: printers, audio/graphic cards, optical storage, hard disk drive
- Industrial: changers, car battery, DC-DC converters

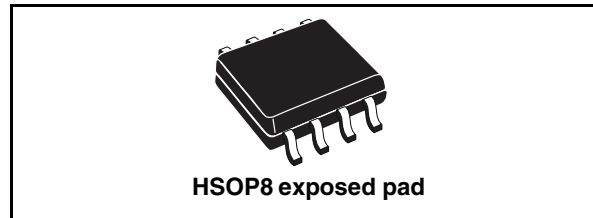

Description

The L5973D is a step down monolithic power switching regulator with a minimum switch current limit of 2.5 A so it is able to deliver more than 2 A DC current to the load depending on the application conditions.

The output voltage can be set from 1.235 V to 35 V. The high current level is also achieved thanks to an SO8 package with exposed frame, that allows to reduce the $R_{th}(j-amb)$ down to approximately 40 °C/W.

The device uses an internal P-channel D-MOS transistor (with a typical R_{dson} of 250 m Ω) as switching element to minimize the size of the external components.

An internal oscillator fixes the switching frequency at 250 kHz.

Having a minimum input voltage of 4 V only, it is particularly suitable for 5 V bus, available in all computer related applications.

Pulse by pulse current limit with the internal frequency modulation offers an effective constant current short circuit protection.

Figure 1. Test application circuit

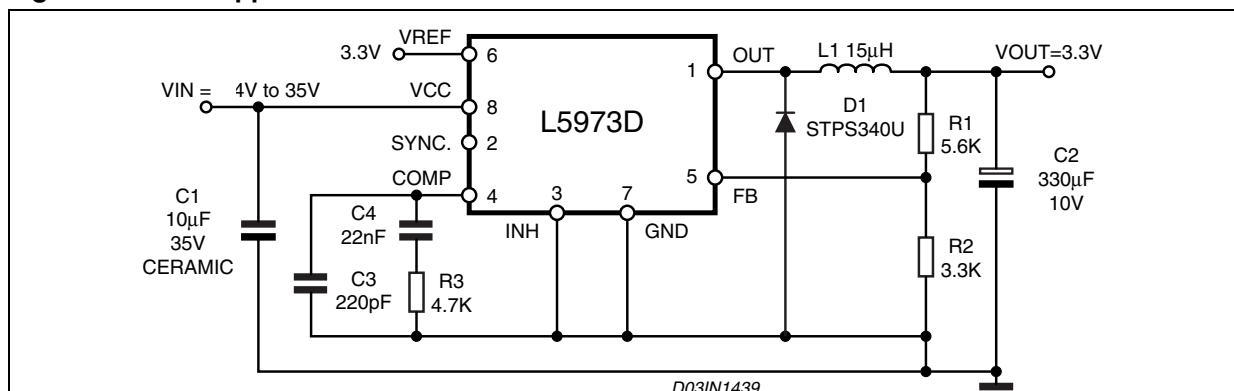

Contents

1	Pin settings	3
	1.1 Pin connection	3
	1.2 Pin description	3
2	Electrical data	4
	2.1 Maximum ratings	4
	2.2 Thermal data	4
3	Electrical characteristics	5
4	Typical characteristics	7
5	Application circuit	9
6	Application ideas	11
7	Package mechanical data	13
8	Order code	15
9	Revision history	16

1 Pin settings

1.1 Pin connection

Figure 2. Pin connection (top view)

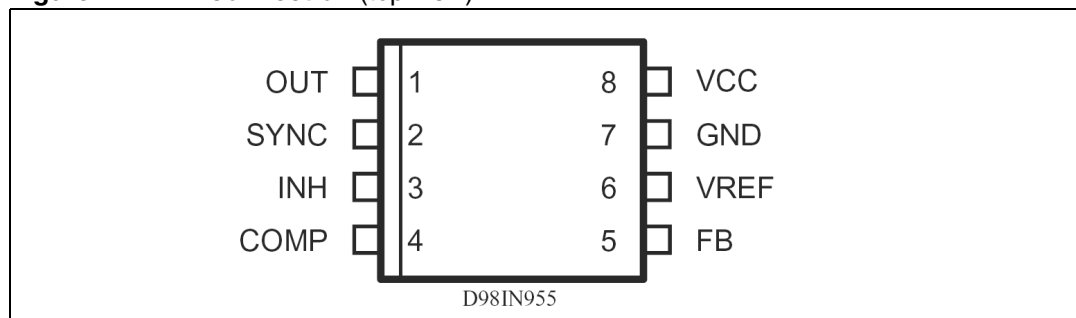

1.2 Pin description

Table 1. Pin description

N°	Type	Description
1	OUT	Regulator output.
2	SYNC	Master/slave synchronization.
3	INH	A logical signal (active high) disables the device. If INH not used the pin must be grounded. When it is open an internal pull-up disable the device.
4	COMP	E/A output for frequency compensation.
5	FB	Feedback input. Connecting directly to this pin results in an output voltage of 1.23 V. An external resistive divider is required for higher output voltages.
6	VREF	3.3 V V_{REF} No cap is requested for stability.
7	GND	Ground.
8	VCC	Unregulated DC input voltage.

2 Electrical data

2.1 Maximum ratings

Table 2. Absolute maximum ratings

Symbol	Parameter	Value	Unit
V_8	Input voltage	40	V
V_1	Output DC voltage	-1 to 40	V
	Output peak voltage at $t = 0.1 \mu\text{s}$	-5 to 40	V
I_1	Maximum output current	int. limit.	
V_4, V_5	Analog pins	4	V
V_3	INH	-0.3 V to V_{CC}	
V_2	SYNC	-0.3 to 4	V
P_{TOT}	Power dissipation at $T_A \leq 60 \text{ }^\circ\text{C}$	2.25	W
T_J	Operating junction temperature range	-40 to 150	$^\circ\text{C}$
T_{STG}	Storage temperature range	-55 to 150	$^\circ\text{C}$

2.2 Thermal data

Table 3. Thermal data

Symbol	Parameter	HSOP8 Exposed Pad	Unit
R_{thJA}	Maximum thermal resistance junction-ambient	40 ⁽¹⁾	$^\circ\text{C}/\text{W}$

1. Package mounted on board

3 Electrical characteristics

Table 4. Electrical characteristics
($T_J = 25\text{ }^\circ\text{C}$, $V_{CC} = 12\text{ V}$, unless otherwise specified)

Symbol	Parameter	Test condition	Min	Typ	Max	Unit	
V_{CC}	Operating input voltage range	$V_O = 1.235\text{ V}$; $I_O = 2\text{ A}$	(1) 4		36	V	
$R_{DS(on)}$	Mosfet on Resistance		(1)	0.250	0.5	Ω	
I_l	Maximum limiting current	$V_{CC} = 4.4\text{ V}$ to 36 V	2.5	3	3.5	A	
f_s	Switching frequency		(1) 212	250	280	kHz	
			225	250	275	kHz	
	Duty cycle		0		100	%	
Dynamic characteristics (see test circuit).							
V_5	Voltage feedback	$4.4\text{ V} < V_{CC} < 36\text{ V}$, $20\text{ mA} < I_O < 2\text{ A}$		1.220	1.235	1.25	V
			(1) 1.198	1.235	1.272	V	
h	Efficiency	$V_O = 5\text{ V}$, $V_{CC} = 12\text{ V}$		90		%	
DC characteristics							
I_{qop}	Total operating quiescent current		(1)	3	5	mA	
I_q	Quiescent current	Duty Cycle = 0; $V_{FB} = 1.5\text{ V}$			2.5	mA	
I_{qst-by}	Total stand-by quiescent current	$V_{inh} > 2.2\text{ V}$	(1)	50	100	μA	
		$V_{CC} = 36\text{ V}$; $V_{inh} > 2.2\text{ V}$	(1)	80	150	μA	
Inhibit							
	INH threshold voltage	Device ON			0.8	V	
		Device OFF		2.2		V	
Error amplifier							
V_{OH}	High level output voltage	$V_{FB} = 1\text{ V}$		3.5		V	
V_{OL}	Low level output voltage	$V_{FB} = 1.5\text{ V}$			0.4	V	
$I_{o\ source}$	Source output current	$V_{COMP} = 1.9\text{ V}$; $V_{FB} = 1\text{ V}$		200	300	μA	
$I_{o\ sink}$	Sink output current	$V_{COMP} = 1.9\text{ V}$; $V_{FB} = 1.5\text{ V}$		1	1.5	mA	

Table 4. Electrical characteristics (continued)
 (T_J = 25 °C, V_{CC} = 12 V, unless otherwise specified)

Symbol	Parameter	Test condition	Min	Typ	Max	Unit	
I _b	Source bias current			2.5	4	μA	
	DC open loop gain	R _L = ∞	50	57		dB	
gm	Transconductance	I _{comp} = -0.1 mA to 0.1 mA V _{COMP} = 1.9 V		2.3		mS	
Sync function							
	High input voltage	V _{CC} = 4.4 V to 36 V	2.5		V _{REF}	V	
	Low input voltage	V _{CC} = 4.4 V to 36 V			0.74	V	
	Slave sink current	V _{sync} = 0.74 V ⁽²⁾ V _{sync} = 2.33 V	0.11		0.25	mA	
			0.21		0.45	mA	
	Master output amplitude	I _{source} = 3 mA	2.75	3		V	
	Output pulse width	no load, V _{sync} = 1.65 V	0.20	0.35		μs	
Reference section							
	Reference voltage		3.234	3.3	3.366	V	
		I _{REF} = 0 to 5 mA V _{CC} = 4.4 V to 36 V	(1)	3.2	3.3	3.399	V
	Line regulation	I _{REF} = 0 mA V _{CC} = 4.4 V to 36 V		5	10	mV	
	Load regulation	I _{REF} = 0 to 5 mA		8	15	mV	
	Short circuit current		10	18	30	mA	

1. Specification Referred to T_J from -40 to 125 °C. Specification over the -40 to +125 T_J Temperature range are assured by design, characterization and statistical correlation.
2. Guaranteed by design.

4 Typical characteristics

Figure 3. Line regulation

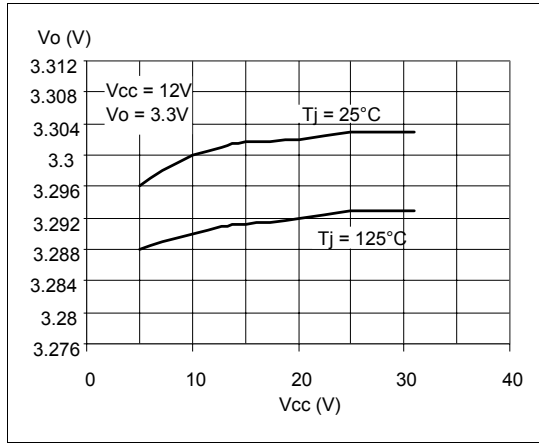

Figure 4. Shutdown current vs junction temperature

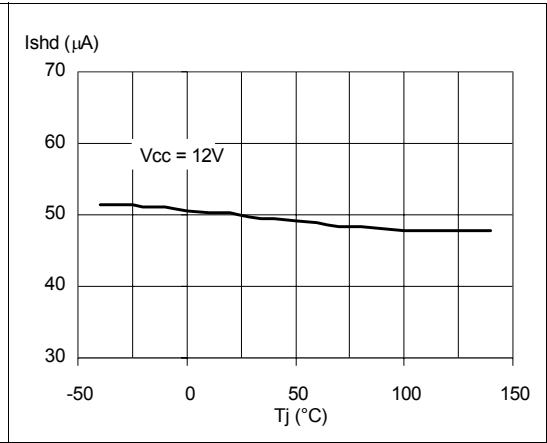

Figure 5. Output voltage vs junction temperature

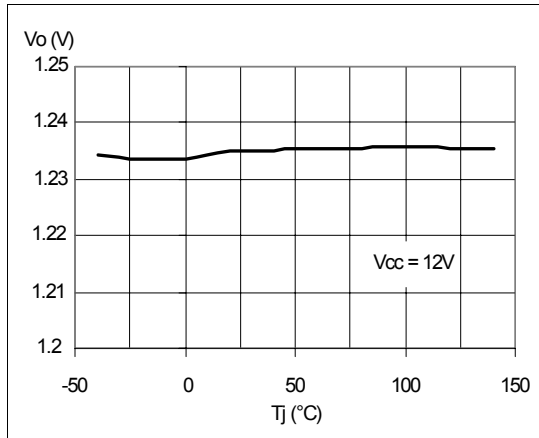

Figure 6. Switching frequency vs junction temperature

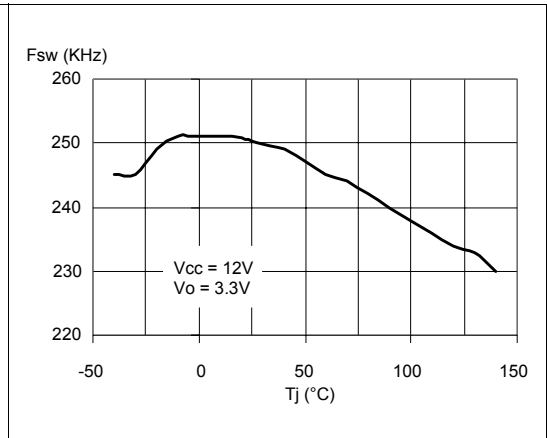

Figure 7. Quiescent current vs junction temperature

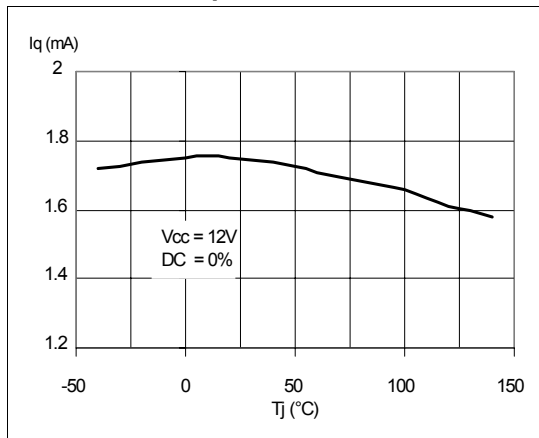

Figure 8. Junction temperature vs output current

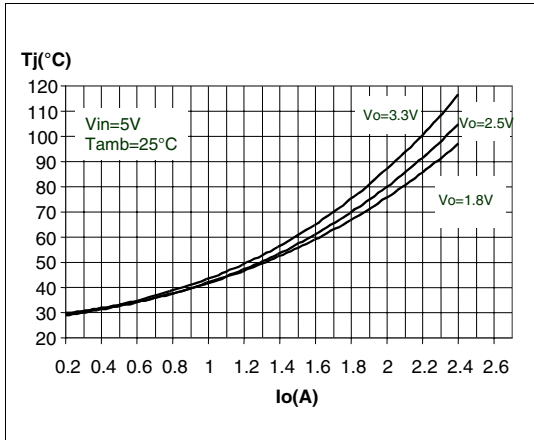

Figure 9. Junction temperature vs output current

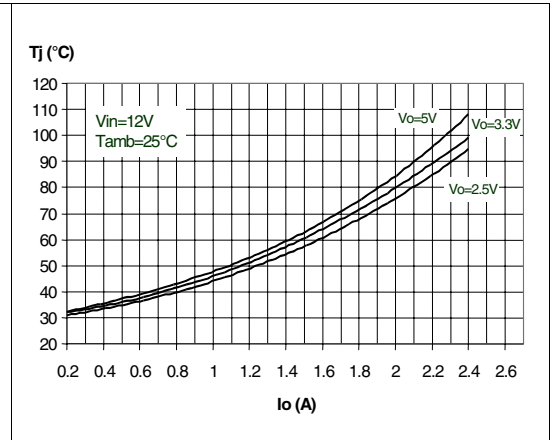

Figure 10. Efficiency vs output current

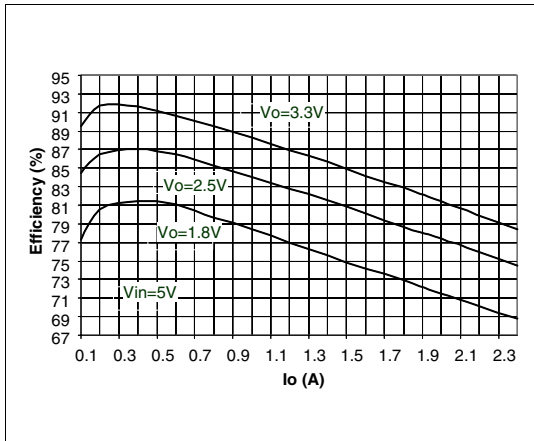
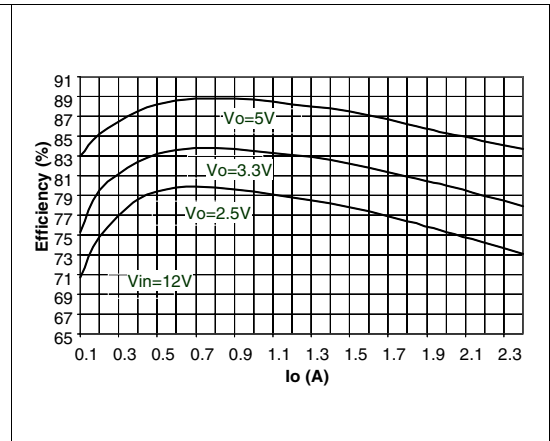

Figure 11. Efficiency vs output current



5 Application circuit

In figure 6 is shown the demonstration board application circuit, where the input supply voltage, V_{CC} , can range from 4 V to 25 V due to the rated voltage of the input capacitor and the output voltage is adjustable from 1.235 V to V_{CC} .

Figure 12. Demonstration board application circuit

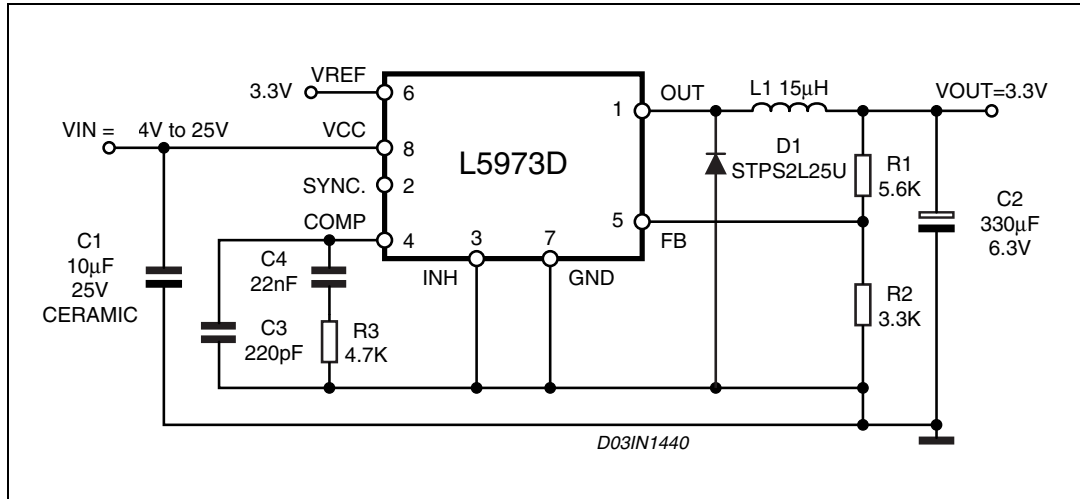

Table 5. Component list

Reference	Part number	Description	Manufacturer
C1	GRM32DR61E106KA12L	10 μ F, 25 V	Murata
C2	POSCAP 6TPB330M	330 μ F, 6.3 V	Sanyo
C3	C1206C221J5GAC	220 pF, 5%, 50 V	KEMET
C4	C1206C223K5RAC	22 nF, 10%, 50 V	KEMET
R1		5.6 K, 1%, 0.1 W 0603	Neohm
R2		3.3 K, 1%, 0.1 W 0603	Neohm
R3		4.7 K, 1%, 0.1 W 0603	Neohm
D1	STPS2L25U	2 A, 25 V	ST
L1	DO3316P-153	15 μ H, 3 A	COILCRAFT

Figure 13. PCB layout (component side)

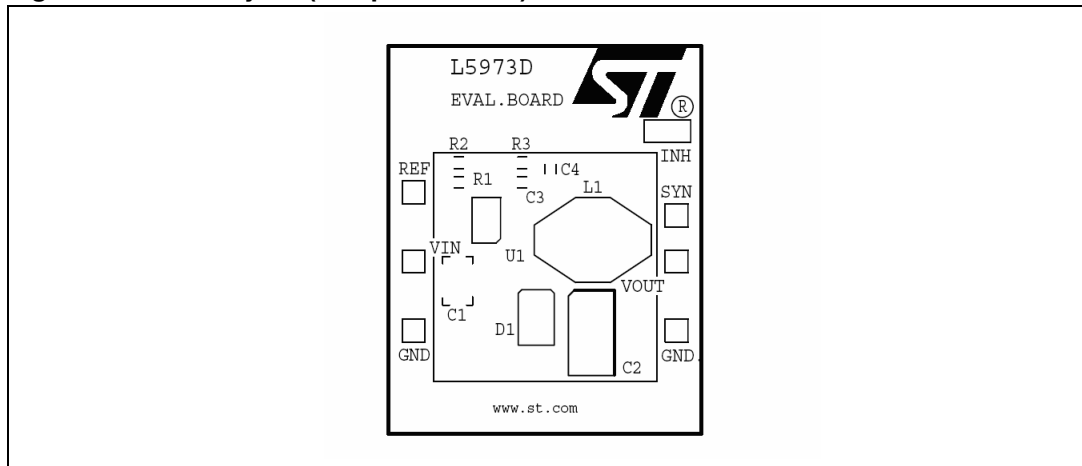

Figure 14. PCB layout (bottom side)

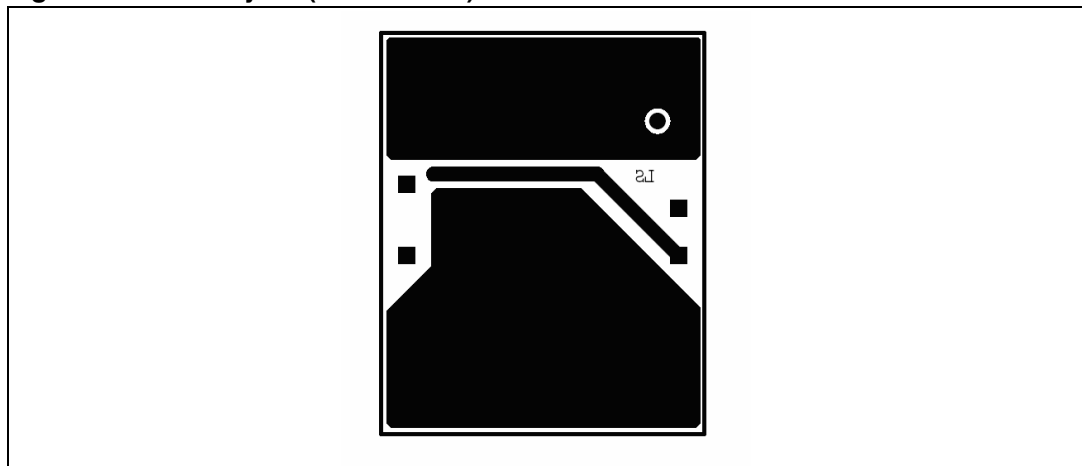
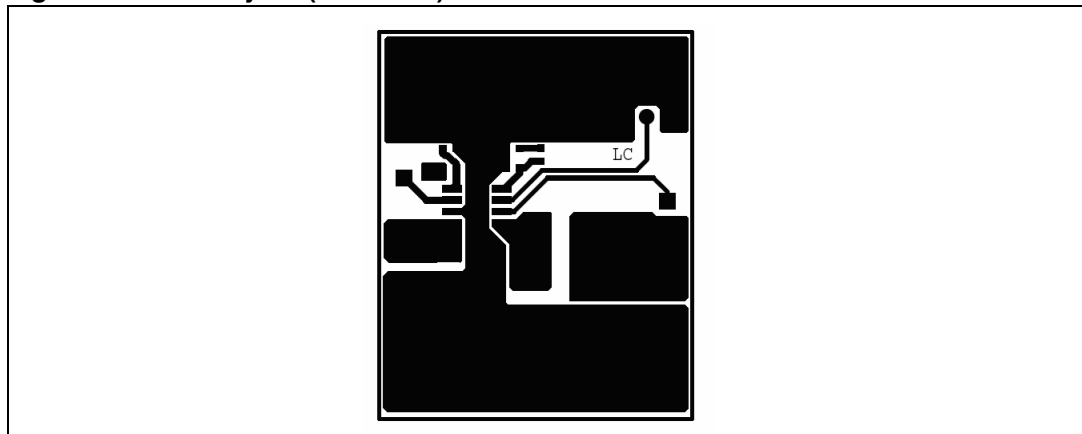

Figure 15. PCB layout (front side)



Below some graphs show the T_J versus output current in different conditions of the input and output voltage and some efficiency measurements.

6 Application ideas

Figure 16. Positive buck-boost regulator

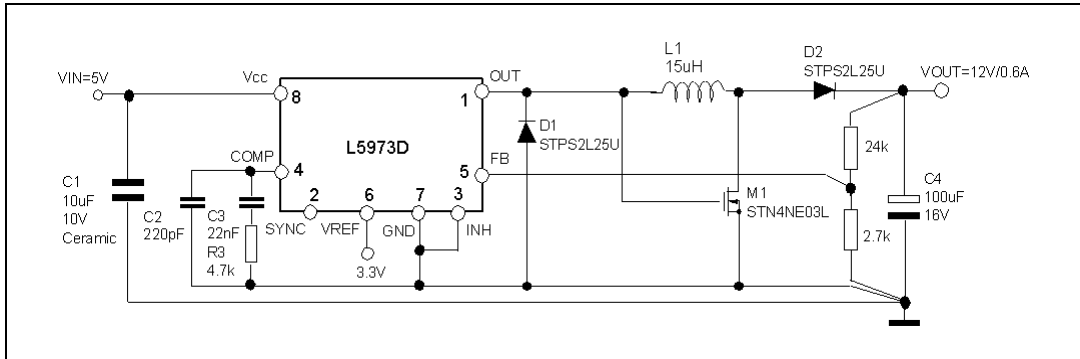

Figure 17. Buck-boost regulator

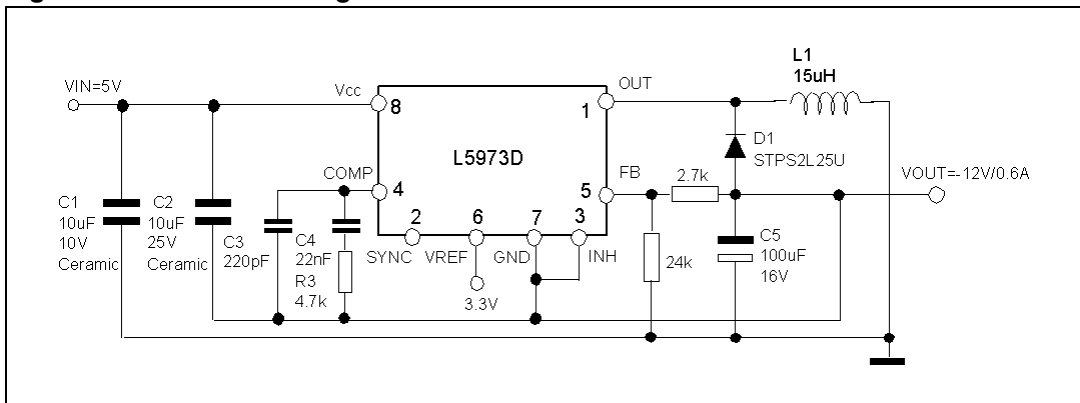
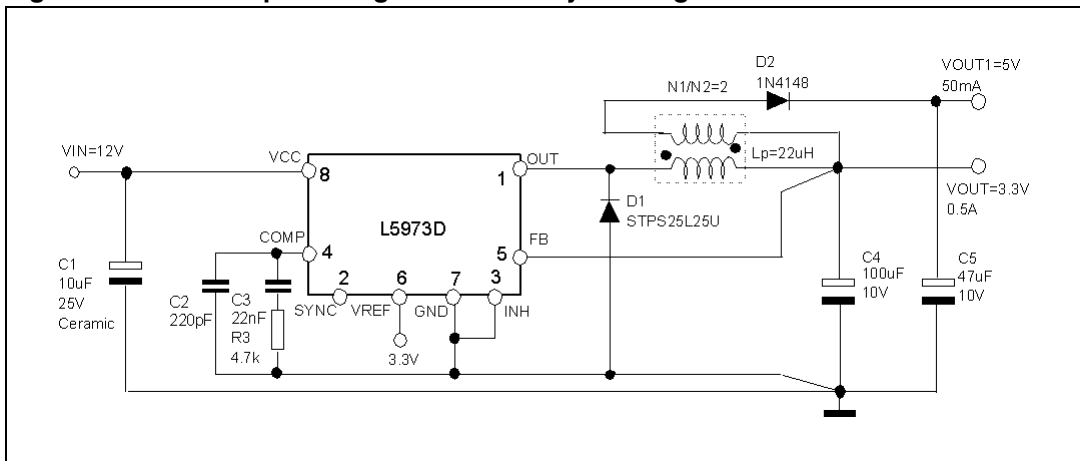

Figure 18. Dual output voltage with auxiliary winding



When an output voltage below the internal reference (1.235 V) is required, the circuit reported in the figure 18 can be used. In this case the minimum voltage reachable is 0.6 V and can be easily calculated with the following formula:

$$V_{OUT} = V_{FB} - [(V_{REF} - V_{FB}) \times (R_2 / R_1)]$$

If the load is not present, a resistor connected between V_{OUT} and GND is required in order to avoid that the voltage across C_{OUT} increases.

The value of this resistor has to be calculated taking into account that the current flowing through this resistance has to be higher than the current flowing through R_2 .

Figure 19. Output voltage below the 1.235 V internal voltage reference

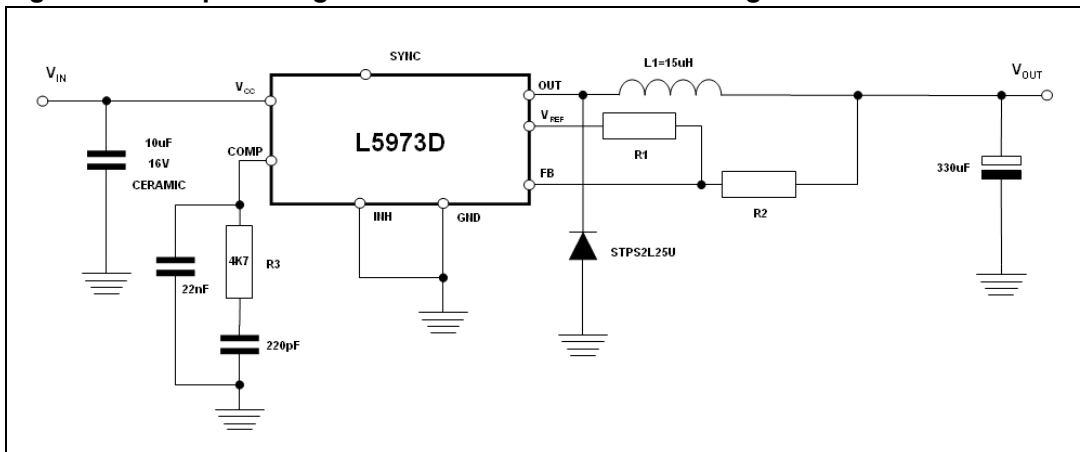

7 Package mechanical data

In order to meet environmental requirements, ST offers these devices in ECOPACK® packages. These packages have a Lead-free second level interconnect . The category of second level interconnect is marked on the package and on the inner box label, in compliance with JEDEC Standard JESD97. The maximum ratings related to soldering conditions are also marked on the inner box label. ECOPACK is an ST trademark. ECOPACK specifications are available at: www.st.com

Table 6. HSOP8 mechanical data

Dim	mm			inch		
	Min	Typ	Max	Min	Typ	Max
A			1.70			0.0669
A1	0.00		0.10		0.00	0.0039
A2	1.25			0.0492		
b	0.31		0.51	0.0122		0.0201
c	0.17		0.25	0.0067		0.0098
D	4.80	4.90	5.00	0.1890	0.1929	0.1969
D1	3	3.1	3.2	0.118	0.122	0.126
E	5.80	6.00	6.20	0.2283		0.2441
E1	3.80	3.90	4.00	0.1496		0.1575
E2	2.31	2.41	2.51	0.091	0.095	0.099
e		1.27				
h	0.25		0.50	0.0098		0.0197
L	0.40		1.27	0.0157		0.0500
k	0° (min), 8° (max)					
ccc			0.10			0.0039

Figure 20. Package dimensions

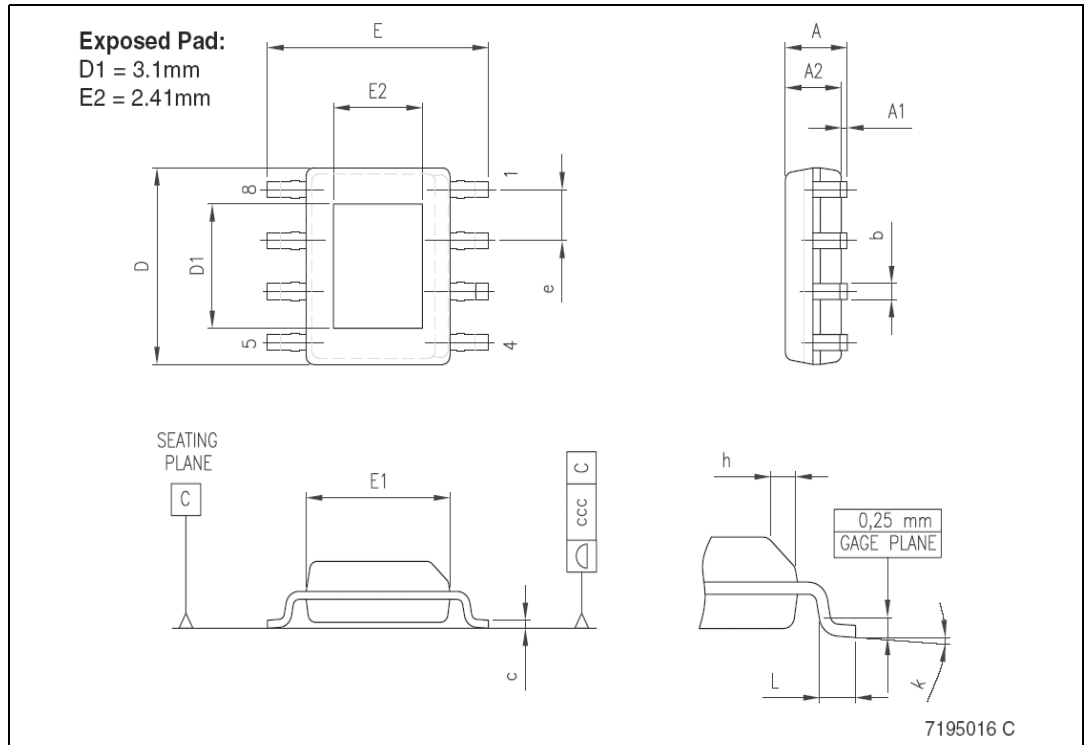

8 Order code

Table 7. Order code

Part number	Package	Packaging
L5973D	HSOP8 (Exposed pad)	Tube
L5973D013TR	HSOP8 (Exposed pad)	Tape and reel

9 Revision history

Table 8. Revision history

Date	Revision	Changes
01-Nov-2005	10	Updated package information
22-May-2006	11	Electrical characteristic Table 4 updated, new application idea Figure 19 added, new template
13-Nov-2006	12	Typo in order codes
26-Jan-2007	13	Updated Table 4 on page 5
17-Oct-2007	14	Updated Section 5: Application circuit on page 9
24-Oct-2007	15	Updated Table 6 on page 14
07-Jan-2008	16	Updated Table 6 on page 14

Please Read Carefully:

Information in this document is provided solely in connection with ST products. STMicroelectronics NV and its subsidiaries ("ST") reserve the right to make changes, corrections, modifications or improvements, to this document, and the products and services described herein at any time, without notice.

All ST products are sold pursuant to ST's terms and conditions of sale.

Purchasers are solely responsible for the choice, selection and use of the ST products and services described herein, and ST assumes no liability whatsoever relating to the choice, selection or use of the ST products and services described herein.

No license, express or implied, by estoppel or otherwise, to any intellectual property rights is granted under this document. If any part of this document refers to any third party products or services it shall not be deemed a license grant by ST for the use of such third party products or services, or any intellectual property contained therein or considered as a warranty covering the use in any manner whatsoever of such third party products or services or any intellectual property contained therein.

UNLESS OTHERWISE SET FORTH IN ST'S TERMS AND CONDITIONS OF SALE ST DISCLAIMS ANY EXPRESS OR IMPLIED WARRANTY WITH RESPECT TO THE USE AND/OR SALE OF ST PRODUCTS INCLUDING WITHOUT LIMITATION IMPLIED WARRANTIES OF MERCHANTABILITY, FITNESS FOR A PARTICULAR PURPOSE (AND THEIR EQUIVALENTS UNDER THE LAWS OF ANY JURISDICTION), OR INFRINGEMENT OF ANY PATENT, COPYRIGHT OR OTHER INTELLECTUAL PROPERTY RIGHT.

UNLESS EXPRESSLY APPROVED IN WRITING BY AN AUTHORIZED ST REPRESENTATIVE, ST PRODUCTS ARE NOT RECOMMENDED, AUTHORIZED OR WARRANTED FOR USE IN MILITARY, AIR CRAFT, SPACE, LIFE SAVING, OR LIFE SUSTAINING APPLICATIONS, NOR IN PRODUCTS OR SYSTEMS WHERE FAILURE OR MALFUNCTION MAY RESULT IN PERSONAL INJURY, DEATH, OR SEVERE PROPERTY OR ENVIRONMENTAL DAMAGE. ST PRODUCTS WHICH ARE NOT SPECIFIED AS "AUTOMOTIVE GRADE" MAY ONLY BE USED IN AUTOMOTIVE APPLICATIONS AT USER'S OWN RISK.

Resale of ST products with provisions different from the statements and/or technical features set forth in this document shall immediately void any warranty granted by ST for the ST product or service described herein and shall not create or extend in any manner whatsoever, any liability of ST.

ST and the ST logo are trademarks or registered trademarks of ST in various countries.

Information in this document supersedes and replaces all information previously supplied.

The ST logo is a registered trademark of STMicroelectronics. All other names are the property of their respective owners.

© 2008 STMicroelectronics - All rights reserved

STMicroelectronics group of companies

Australia - Belgium - Brazil - Canada - China - Czech Republic - Finland - France - Germany - Hong Kong - India - Israel - Italy - Japan - Malaysia - Malta - Morocco - Singapore - Spain - Sweden - Switzerland - United Kingdom - United States of America

www.st.com



Looking for pricing, stock, or lifecycle information?

Click below to explore more details on WIN SOURCE:

- ⊖ [View STEVAL-ISA101V1 on WIN SOURCE](#)
- ⊖ [STMicroelectronics Information](#)

Optimize Your Supply Chain with WIN SOURCE Solutions

- ✓ Global Sourcing Solution
- ✓ Obsolete Management
- ✓ Cost Control Management
- ✓ Shortage Management
- ✓ Alternative Solution
- ✓ Excess Inventory Management