



**THE DATASHEET OF
TPS65030EVM-162**



TPS65030 Power-Management IC for USB-OTG

1 Features

- Four Regulated Output Voltages With 3% Tolerance
 - Fractional Charge Pump for 5 V, 100 mA
 - Fractional Charge Pump for 1.5 V, 200 mA
 - Doubling Charge Pump With LDO Mode for 3.3 V, 22 mA
 - LDO for 1.8 V, 60 mA
- Switching Frequency 1 MHz
- 3-V to 5-V Operating Input Voltage Range at V_{CC} Pin
- Sleep Mode Sets V_{out2} and V_{out3} Into LDO Mode
- Sleep Mode Reduces Quiescent Current of V_{out2} , V_{out3} , and V_{out4} to 8- μ A Each
- Internal Bus Switch
- V_{bus} Comparator
- Internal Soft Start Limits Inrush Current
- Low Input Current Ripple and Low EMI
- Overcurrent and Overtemperature Protected
- Undervoltage Lockout With Hysteresis
- Ultra-Small 2.50-mm \times 2.70-mm Chip Scale Package Applications

2 Applications

- Power Supply for USB OTG for:
 - Cellular Phones
 - Smart Phones
 - PDAs
 - Handheld PCs
 - Digital Cameras
 - Camcorders

3 Description

The TPS65030 device contains three charge pumps and one LDO to generate all supply voltages necessary for a USB On-The-Go (OTG) implementation using TUSB6010. The charge pumps are optimized for a single Li-Ion cell input or for 5 V from the USB bus. The input voltage range is 3 V to 5 V for the battery voltage. High efficiency is achieved by using fractional conversion techniques for the charge pumps in combination with a power saving sleep mode. The current-controlled charge pumps ensure low input current ripple and low EMI. Small sized external ceramic capacitors are required to build a complete power-supply solution. To reduce board space to a minimum, the device switches at 1-MHz operating frequency and is available in a small 25-ball chip scale package (YZK).

Device Information⁽¹⁾

PART NUMBER	PACKAGE	BODY SIZE (MAX)
TPS65030	DSBGA (25)	2.51 mm \times 2.70 mm

(1) For all available packages, see the orderable addendum at the end of the data sheet.

Functional Block Diagram

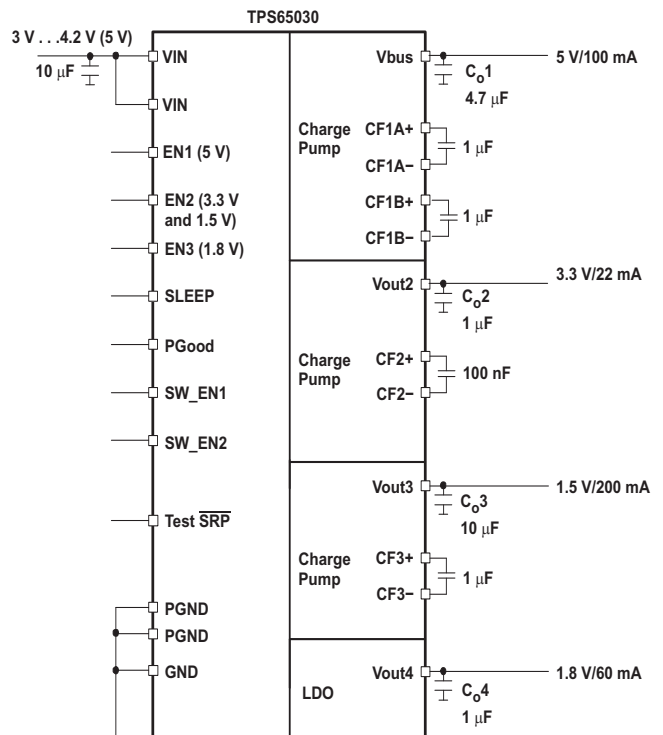

Table of Contents

1 Features 1 2 Applications 1 3 Description 1 4 Revision History 2 5 Pin Configuration and Functions 3 6 Specifications 4 6.1 Absolute Maximum Ratings 4 6.2 ESD Ratings 4 6.3 Recommended Operating Conditions 4 6.4 Thermal Information 5 6.5 Electrical Characteristics 5 6.6 Timing Requirements 8 6.7 Typical Characteristics 9 7 Detailed Description 10 7.1 Overview 10 7.2 Functional Block Diagrams 10 7.3 Feature Description 11	7.4 Device Functional Modes 14 8 Application and Implementation 16 8.1 Application Information 16 8.2 Typical Application 16 9 Power Supply Recommendations 20 9.1 Power Dissipation 20 10 Layout 22 10.1 Layout Guidelines 22 10.2 Layout Example 22 11 Device and Documentation Support 23 11.1 Device Support 23 11.2 Community Resources 23 11.3 Trademarks 23 11.4 Electrostatic Discharge Caution 23 11.5 Glossary 23 12 Mechanical, Packaging, and Orderable Information 23
---	--

4 Revision History

NOTE: Page numbers for previous revisions may differ from page numbers in the current version.

Changes from Revision B (July 2007) to Revision C	Page
<ul style="list-style-type: none"> • Added <i>ESD Ratings</i> table, <i>Feature Description</i> section, <i>Device Functional Modes</i>, <i>Application and Implementation</i> section, <i>Power Supply Recommendations</i> section, <i>Layout</i> section, <i>Device and Documentation Support</i> section, and <i>Mechanical, Packaging, and Orderable Information</i> section 	1

5 Pin Configuration and Functions

**YZK Package
25-Pin DSBGA
Bottom View**

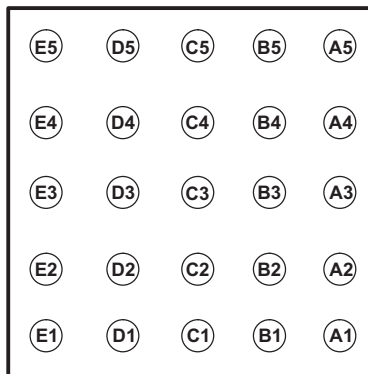

Pin Functions

PIN		I/O	LOGIC FUNCTION	DESCRIPTION
NAME	NO.			
CF1A+	C1	—	—	Connect to the flying capacitor CF1A
CF1A–	E1	—	—	Connect to the flying capacitor CF1A
CF1B+	B1	—	—	Connect to the flying capacitor CF1B
CF1B–	D1	—	—	Connect to the flying capacitor CF1B
CF2+	D5	—	—	Connect to the flying capacitor CF2
CF2–	E5	—	—	Connect to the flying capacitor CF2
CF3+	A3	—	—	Connect to the flying capacitor CF3
CF3–	A5	—	—	Connect to the flying capacitor CF3
EN1	B3	I	1 = Vbus converter enabled 0 = Vbus converter disabled	Enable input for 5-V charge pump. A logic low forces the charge pump into shutdown mode reducing the supply current to less than 1 μ A.
EN2	B4	I	1 = Vout2 and Vout3 enabled 0 = Vout2 and Vout3 disabled	Enable input for 3.3-V and 1.5-V charge pump. Logic low forces both charge pumps into shutdown mode reducing the supply current to less than 1 μ A.
EN3	C4	I	1 = Vout4 enabled 0 = Vout4 disabled	Enable input for 1.8-V LDO. Logic low forces the LDO into shutdown mode reducing the supply current to less than 1 μ A. To ensure that EN3 is pulled to GND when left open, there is an internal pull-down resistor to GND.
GND	D4	—	—	Analog ground
PGND	E2, B5	—	—	Power ground
PGood	D3	O	1 = output voltage within limits 0 = output voltage too low	Open drain power good output for Vout2, Vout3, and Vout4
SLEEP	B2	I	1 = sleep mode 0 = normal mode	This pin is used to set the 3.3-V and 1.5-V charge pump as well as the 1.8-V LDO into sleep mode. Logic low forces the charge pumps into normal operating mode if they are enabled.
SW_EN1	C3	I	1 = Vout3 switchover to Vbus enabled 0 = Vout3 is battery powered	Enable input 1 for internal USB switch. If this input is pulled high, the Vout3 converter is powered from Vbus. If SLEEP is pulled high, the converter is always powered from the battery, independent from the state of SW_EN1.
SW_EN2	C2	I	1 = Vout2 switchover to Vbus enabled 0 = Vout2 is battery powered	Enable input 2 for internal USB switch. If this input is pulled high, the Vout2 converter is powered from Vbus. If SLEEP is pulled high, the converter is always powered from the battery, independent from the state of SW_EN2.
Test SRP	D2	I/O	Input: 1 = I _O at Vbus = 100 mA 0 = I _O at Vbus = 1 mA	Open-drain output for connectivity test, input for current limit during start-up for Vbus voltage if the device is not in test mode. If Test SRP is pulled high, the Vbus current during startup is > 100 mA. If pulled low, it is 1 mA.
Vbus	E3	I/O	—	Output for the 5-V charge pump. Connect the output capacitor directly to this pin. This pin is also the input for the 5-V from the USB port, if the USB port powers the 3.3-V and 1.5-V charge pump as well as the 1.8-V LDO.
VIN	A1, A2	I	—	Supply voltage input
Vout2	C5	O	—	Output for the 3.3-V charge pump. Connect Cout2 directly to this pin.
Vout3	A4	O	—	Output for the 1.5-V charge pump. Connect Cout3 directly to this pin.
Vout4	E4	O	—	Output for the 1.8-V LDO. Connect Cout4 directly to this pin.

6 Specifications

6.1 Absolute Maximum Ratings

 over operating free-air temperature range (unless otherwise noted) ⁽¹⁾

		MIN	MAX	UNIT
Supply voltage, V_S	VIN, Vbus	-0.3	7	V
Voltage	EN1, EN2, EN3, SLEEP, SW_EN1, SW_EN2, PG, Test \overline{SRP}	-0.3	VIN	V
Output current, I_O	Vbus		200	mA
	Vout2		40	mA
	Vout3		300	mA
	Vout4		100	mA
Maximum junction temperature, T_J			150	°C
Operating free-air temperature, T_A		-40	85	°C
Storage temperature, T_{stg}		-65	150	°C

- (1) Stresses beyond those listed under *Absolute Maximum Ratings* may cause permanent damage to the device. These are stress ratings only, which do not imply functional operation of the device at these or any other conditions beyond those indicated under *Recommended Operating Conditions*. Exposure to absolute-maximum-rated conditions for extended periods may affect device reliability.

6.2 ESD Ratings

		VALUE	UNIT
$V_{(ESD)}$ Electrostatic discharge	Human body model (HBM), per ANSI/ESDA/JEDEC JS-001 ⁽¹⁾	±2000	V
	Charged device model (CDM), per JEDEC specification JESD22-C101 ⁽²⁾	±500	

- (1) JEDEC document JEP155 states that 500-V HBM allows safe manufacturing with a standard ESD control process.
 (2) JEDEC document JEP157 states that 250-V CDM allows safe manufacturing with a standard ESD control process.

6.3 Recommended Operating Conditions

over operating free-air temperature range (unless otherwise noted)

		MIN	NOM	MAX	UNIT
V_S	Supply voltage at VIN	3		5	V
I_O	Maximum output current at Vbus	100			mA
	Maximum output current at Vout2	22			mA
	Maximum output current at Vout3	200			mA
	Maximum output current at Vout4	50			mA
C_I	Input capacitor at VIN	8	10		µF
C_{O1}	Output capacitance at Vbus	3	4.7	6.5 ⁽¹⁾	µF
	Output capacitance at Vbus required for stability, for $V_I \leq 4.2$ V	2			µF
C_{O2}	Output capacitance at Vout2	0.8	1		µF
C_{O3}	Output capacitance at Vout3	8	10		µF
C_{O4}	Output capacitance at Vout4	0.8	1		µF
	Capacitance for flying capacitor, CF1A, CF1B	0.8	1		µF
	Capacitance for flying capacitor CF3	0.7	1		µF
	Capacitance for flying capacitor CF2	0.077	0.1		µF
T_J	Operating junction temperature	-40		125	°C

- (1) Per USB specification.

6.4 Thermal Information

THERMAL METRIC ⁽¹⁾		TPS65030	
		YZK (DSBGA)	UNIT
		25 PINS	
R _{θJA}	Junction-to-ambient thermal resistance	87.4	°C/W
R _{θJC(top)}	Junction-to-case (top) thermal resistance	5.5	°C/W
R _{θJB}	Junction-to-board thermal resistance	35	°C/W
ψ _{JT}	Junction-to-top characterization parameter	13.5	°C/W
ψ _{JB}	Junction-to-board characterization parameter	33.1	°C/W

(1) For more information about traditional and new thermal metrics, see the *Semiconductor and IC Package Thermal Metrics* application report, [SPRA953](#).

6.5 Electrical Characteristics

V_{IN} = 3.6 V, C_I = 10 μF, T_A = –40°C to 85°C (unless otherwise noted)

PARAMETER		TEST CONDITIONS	MIN	TYP	MAX	UNIT
SUPPLY VOLTAGE AND CURRENT						
V _I	Input voltage, V _{IN}		3		5	V
UVLO	Undervoltage lockout threshold	Input voltage at V _{CC} rising (device switches on)	2.91		3	V
		Input voltage at V _{CC} falling (device switches off)	2.79		2.98	
	Undervoltage lockout hysteresis			80		mV
I _S	Supply current in normal mode if EN1=1, (V _{bus})	V _I = 4.2 V		55	80	μF
	Supply current in normal mode if EN2=1, (V _{out2} , V _{out3})			70	95	μF
	Supply current in normal mode if EN2=EN3=1, (V _{out2} , V _{out3} , V _{out4})			80	115	μF
	Supply current in normal mode if EN1=EN2=1, (V _{bus} , V _{out2} , V _{out3})			110	145	μF
	Supply current in normal mode if EN1=EN2=EN3=1, (V _{bus} , V _{out2} , V _{out3} , V _{out4})			125	170	μF
	Supply current in sleep mode if EN2=1, (SLEEP, V _{out2} , V _{out3})			25	30	μF
	Supply current in sleep mode if EN2=EN3=1, (SLEEP, V _{out2} , V _{out3} , V _{out4})			30	38	μF
I _{SD}	Shutdown current		0.12		1	μF
CHARGE PUMP STAGE FOR V_{bus}						
V _O	V _{BUS} Output voltage			5		V
	Output voltage tolerance		–4%		3%	
	Output voltage ripple	C _{O1} = 4.7 μF, I _{O1} = 100 mA Real cap including aging, DC bias		30		mV _{PP}
			40			
I _O	Maximum output current	For V _{bus} > 2.5 V or \overline{SRP} = high	100			mA
	Output current limit	For V _{bus} > 2.5 V, V _{bus} > V _I – 0.5 V		160	325	mA
	Output current for Session Request Protocol (SRP)	For V _{bus} < 2.5 V, \overline{SRP} = low	0.5	1.3	1.7	mA
	Output current	V _{bus} shorted to GND, \overline{SRP} = high			325	mA
	Skip current limit			30		mA
f	Switching frequency		0.83	1	1.17	MHz
η	Efficiency	V _{IN} = 3.6 V, I _{O1} = 100 mA		85%		
	Input current limit			400	650	mA
	Output resistance when disabled	EN1 = 0	45		100	kΩ

Electrical Characteristics (continued)
 $V_{IN} = 3.6\text{ V}$, $C_1 = 10\ \mu\text{F}$, $T_A = -40^\circ\text{C}$ to 85°C (unless otherwise noted)

PARAMETER		TEST CONDITIONS	MIN	TYP	MAX	UNIT
CHARGE PUMP STAGE FOR Vout2						
V_O	Output voltage, Vout2	Normal mode		3.3		V
	Output voltage tolerance		-3%		3%	
	Output voltage ripple	$C_{O2} = 1\ \mu\text{F}$, $I_{O2} = 22\ \text{mA}$ Real cap including aging, DC bias (0.58 μF)		15 30		mV _{PP}
I_O	Maximum output current	Normal mode	22			mA
	Output current limit	Normal mode ⁽¹⁾		50	70	mA
V_O	Output voltage, Vout2	Sleep mode (LDO mode only)		3.3		V
	Output voltage tolerance in sleep mode	V_O drops with the battery for an input voltage less than 3.3 V	-10%		4%	
	Maximum output current	Sleep mode	100			μA
	Voltage drop in sleep mode	Sleep mode, $I_{O2} = 100\ \mu\text{A}$		25	150	mV
	Output current limit in sleep mode	Vout2 shorted to GND		5	10	mA
	Skip current limit			5		mA
f	Switching frequency		0.83	1	1.17	MHz
η	Efficiency	$V_{IN} = 3.6\ \text{V}$, $I_{O2} = 22\ \text{mA}$, $V_{out2} = 3.3\ \text{V}$		90%		
	Input current limit	LDO mode		50	70	mA
	Input current limit	Charge pump mode		100	140	mA
$V_{(PG2)}$	Power good threshold	Based on the nominal output voltage (3.3 V) Vout2 increasing	-15%			
CHARGE PUMP STAGE FOR Vout3						
V_O	Output voltage, Vout3	Normal mode		1.5		V
	Output voltage tolerance		-3%		3%	
	Output voltage ripple	$C_{O3} = 10\ \mu\text{F}$, $I_{O3} = 200\ \text{mA}$		30		mV _{PP}
I_O	Maximum output current	Normal mode	200			mA
	Output current limit	Normal mode ⁽²⁾		400	600	mA
V_O	Output voltage	Sleep mode		1.5		V
	Output voltage tolerance in sleep mode		-4%		4%	
	Maximum output current	Sleep mode	100			μA
	Output current limit in sleep mode	Vout3 shorted to GND		5	10	mA
	Skip current limit			20		mA
f	Switching frequency		0.83	1	1.17	MHz
η	Efficiency	$V_{IN} = 3.6\ \text{V}$, $I_{out3} = 200\ \text{mA}$, $V_{out3} = 1.5\ \text{V}$		80%		
	Input current limit	LDO mode		400	600	mA
	Input current limit	Charge pump mode		200	300	mA
$V_{(PG3)}$	Power good threshold	Based on the nominal output voltage (1.5 V) Vout3 increasing	-10%			

(1) Overload condition, current is approximately 25 mA if the output is shorted to GND.

(2) Overload condition, current is lower if the output is shorted to GND.

Electrical Characteristics (continued)

VIN = 3.6 V, C_I = 10 μF, T_A = –40°C to 85°C (unless otherwise noted)

PARAMETER		TEST CONDITIONS	MIN	TYP	MAX	UNIT
LDO FOR Vout4						
V _O	Output voltage, Vout4		1.8			V
	Output voltage tolerance	Normal mode	–3%		3%	
I _O	Maximum output current	Normal mode	60			mA
	Output current limit	Normal mode		110	160	mA
	Maximum output current	Sleep mode	100			μA
	Output voltage tolerance in sleep mode		–4%		4%	
	Current limit in sleep mode	Vout4 shorted to GND		5	10	mA
V _(PG4)	Power good threshold	Based on the nominal output voltage (1.8 V) Vout4 increasing	–10%			
Vbus SWITCH						
	Vbus comparator turn off threshold	SW_ENx = 1, Vbus voltage falling	4.3		4.45	V
	Vbus comparator hysteresis		75	110	145	mV
V _{IH}	SW_EN1, SW_EN2, high level input voltage		1.2			V
V _{IL}	SW_EN1, SW_EN2, low level input voltage				0.3	V
	SW_EN1, SW_EN2 trip point hysteresis			50		mV
I _{ikg}	SW_EN1, SW_EN2 input resistance			1		MR
	Quiescent current for Vbus comparator	SW_EN1 = 1 and/or SW_EN2 = 1		2.5	5	μA
Enable1, Enable2, Enable3, Sleep, SRP						
V _{IH}	EN1, EN2, EN3, Sleep, SRP high level input voltage		1.2			V
V _{IL}	EN1, EN2, EN3, Sleep, SRP low level input voltage				0.435	V
	EN1, EN2, EN3, Sleep, SRP trip point hysteresis			50		mV
I _{ikg}	EN1, EN2, Sleep, SRP input leakage current			0.01	0.2	μA
	EN3 input resistance to GND			1		MR
	Thermal shutdown temperature	Temperature rising		155		°C
	Thermal shutdown hysteresis		20			°C
POWER GOOD						
V _{OH}	High-level output voltage	(open drain output)			5	V
V _{OL}	Low-level output voltage	(open drain output); I _o = 1 mA			0.3	V
	Supply voltage at VIN for power good circuit actively pulled low		2			V

6.6 Timing Requirements

		MIN	NOM	MAX	UNIT
Start-up time	$C_{O1} = 2 \times 4.7 \mu\text{F}$, $I_O = 100 \text{ mA}^{(1)}$, excluding time for SRP ⁽²⁾		500		μs
Start-up time	$C_{O1} = 106 \mu\text{F}$, $I_O = 100 \text{ mA}^{(1)}$, excluding time for SRP ⁽²⁾		4.5		ms
Start-up time	$C_{O2} = 1 \mu\text{F}$, $I_{O2} = 22 \text{ mA}^{(2)}$		200		μs
Start-up time	$C_{O3} = 10 \mu\text{F}$, $I_{O3} = 200 \text{ mA}^{(2)}$		100		μs
Start-up time	$C_{O4} = 1 \mu\text{F}$, $I_{O4} = 60 \text{ mA}^{(2)}$		100		μs
Turnon delay time	Switching from V_I to V_{bus}			5	μs
Turnoff delay time	Switching from V_{bus} to V_I			3	μs
SLEEP exit time				8	μs
SLEEP entry time				8	μs
Delay time	Low to high transition	3.1		6	ms
Filter time	High to low transition		25		μs

(1) For $V_{\text{bus}} > 2.5 \text{ V}$, otherwise $I_O = 0 \text{ mA}$

(2) Startup time is measured from ENx-pin going high to V_O within nominal value.

6.7 Typical Characteristics

Table 1. Table of Graphs

		FIGURE
η Efficiency	vs Input Voltage at Vbus	Figure 1
	vs Input Voltage at Vout2	Figure 2
	vs Input Voltage at Vout3	Figure 3

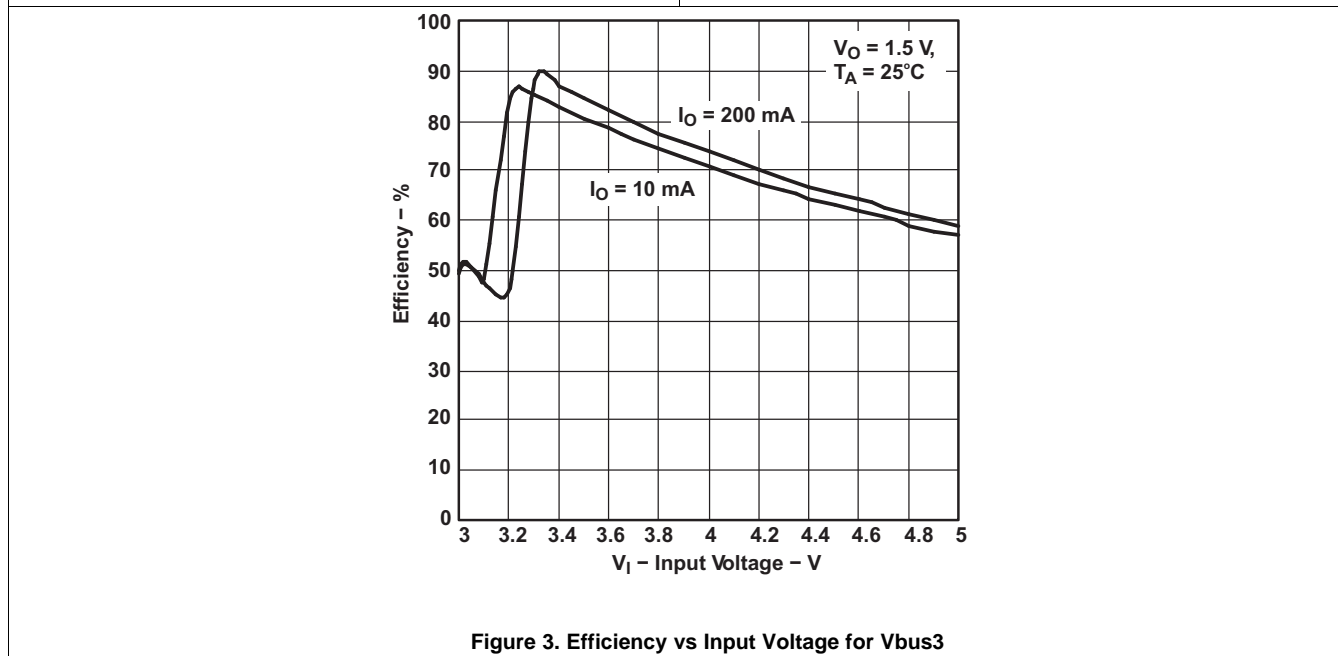
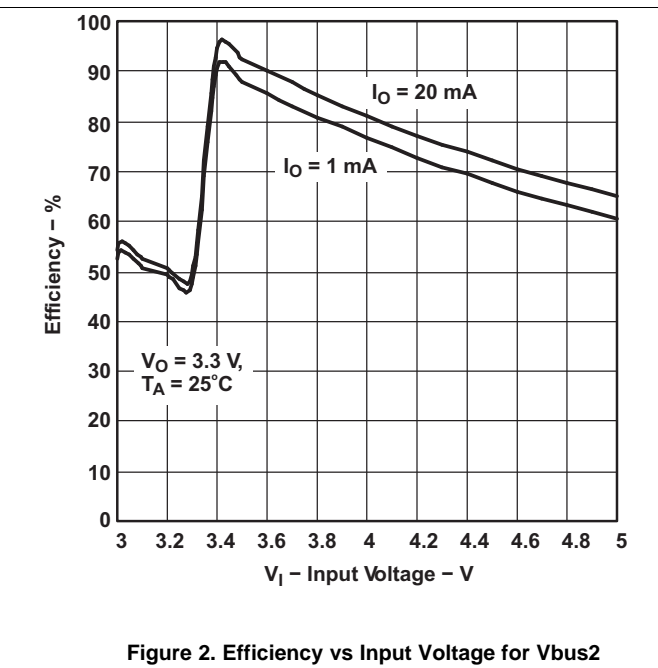
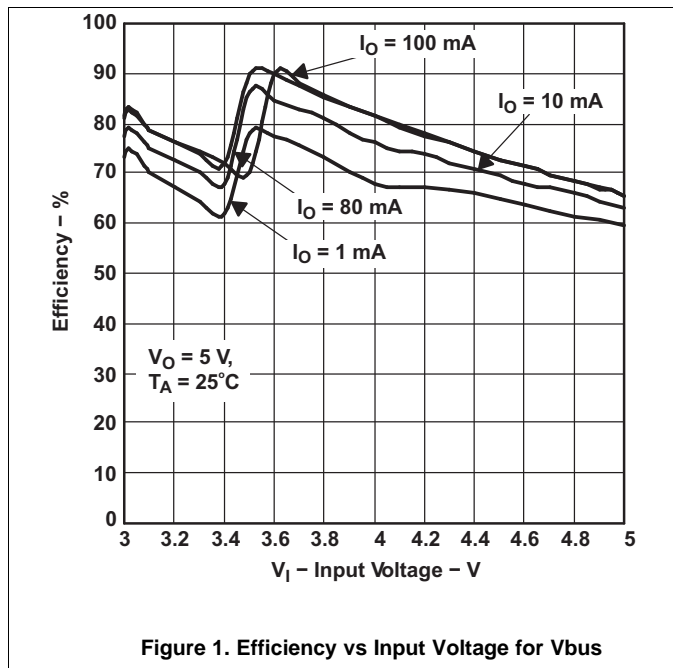

7 Detailed Description

7.1 Overview

The TPS65030 device uses fractional conversion charge pumps to generate the supply voltage for an integrated USB-OTG chip (TUSB6010). Depending on the input voltage, output voltage, and output current, the charge pumps operate in different conversion modes. By switching automatically between these different modes, the circuit optimizes the power-conversion efficiency as well as extends operating.

7.2 Functional Block Diagrams

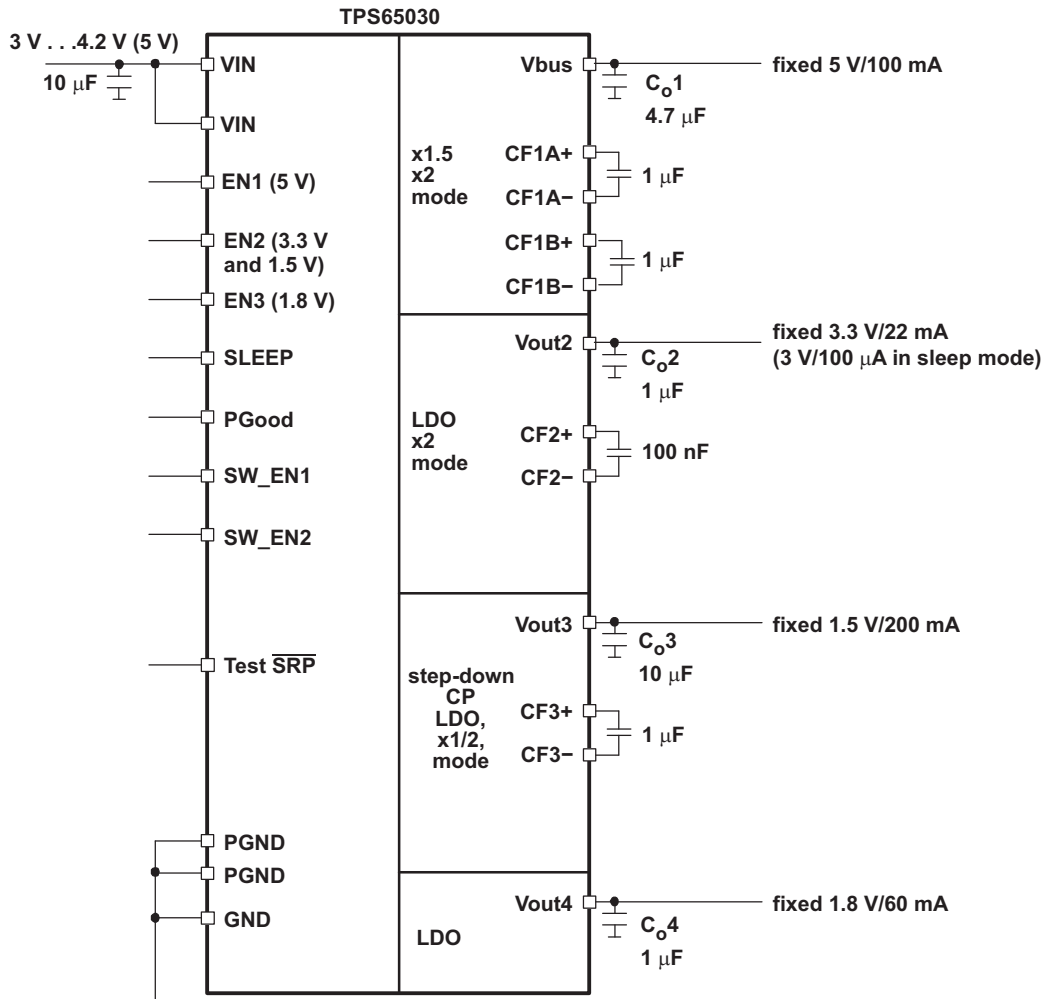

Figure 4. Functional Block Diagram

Functional Block Diagrams (continued)

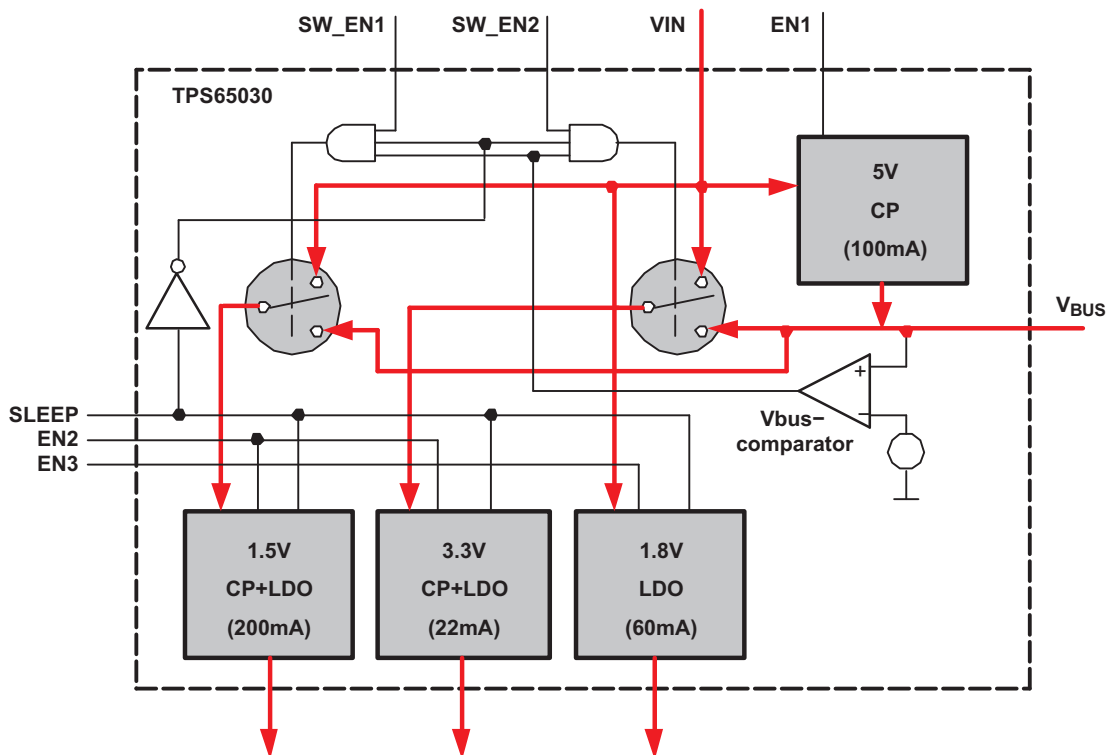
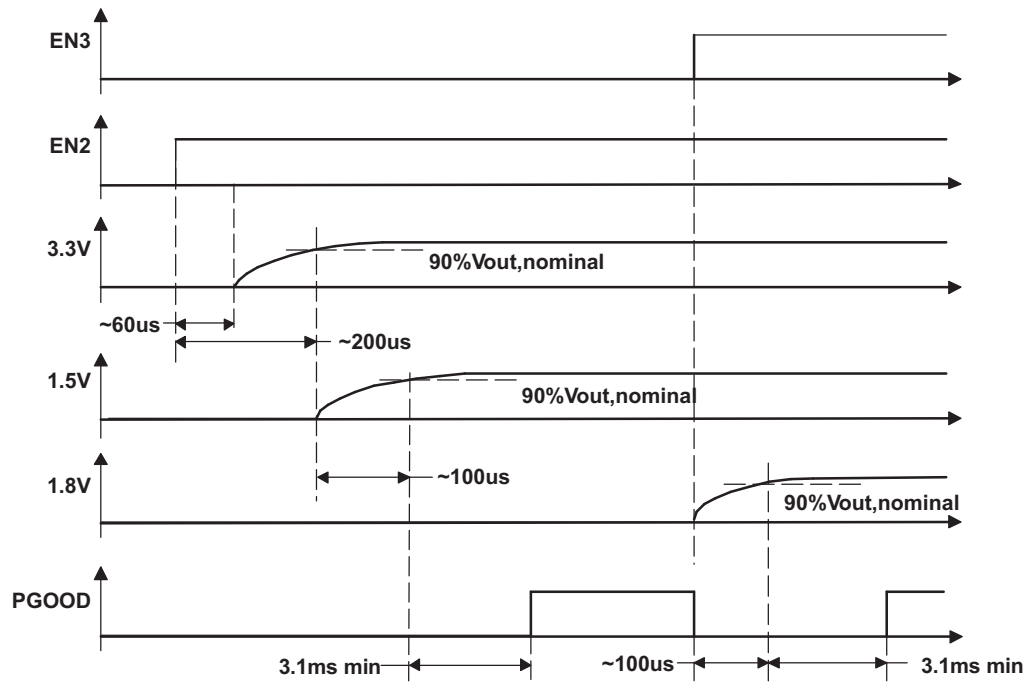

Figure 5. Internal Block Diagram

7.3 Feature Description

7.3.1 Enable (EN1, EN2, EN3)

There are three different enable signals available. EN1 activates the 5-V converter associated with Vbus if it is pulled high. EN2 is associated with the 3.3-V converter (Vout2) and the 1.5-V converter (Vout3). If EN2 is pulled high, the 3.3-V ramps up first, followed by the 1.5-V converter, see Figure 6. EN3 enables the 1.8-V LDO (Vout4) if pulled high. For EN3, there is an internal pulldown resistor to GND, disabling the Vout4-LDO if the EN3 pin is left open.

Feature Description (continued)

Figure 6. Timing Diagram
7.3.2 Soft Start

The TPS65030 has an internal soft-start circuit that limits the inrush current during start-up. This prevents possible voltage drops of the input voltage if a high impedance power source is connected to the input of the TPS65030. The input current for each converter is limited to about twice the nominal input current in normal operating.

7.3.3 Switch_Enable (SW_EN1, SW_EN2)

The enable pins SW_EN1 and SW_EN2 are used to activate an internal switch that connects the input for the 3.3-V charge pump and the input of the 1.5-V charge pump with either the Li-ion battery or the USB bus voltage of 5 V. SW_EN1 controls the bus switch for Vout3 (1.5 V), while SW_EN2 controls the bus switch for Vout2 (3.3 V). Vout1 and Vout4 are always battery powered. Both inputs are active high. The turnover from V_I to Vbus is handled in such a way that the SW_ENx signals are used as an enable signal to the bus switch. Switchover, however, occurs based on the status of the Vbus comparator. The Vbus comparator senses the voltage at Vbus. If the voltage is above the threshold, the power source for the converters, enabled by SW_ENx is switched from the battery to the USB bus voltage. If the voltage at Vbus drops below the threshold, the power source is switched back to the battery again. The internal Vbus comparator is disabled if both SW_EN1 and SW_EN2 are low, to reduce the quiescent current of the device.

7.3.4 Sleep

The TPS65030 offers a power save mode (sleep mode), that reduces the maximum output current of the converters for Vout2, Vout3 and Vout4. The Maximum output current for each converter is reduced to 100 μ A. In sleep mode, the quiescent supply current for each converter is reduced to 8- μ A maximum. Sleep mode is entered when the sleep pin is pulled high. In sleep mode, all converters are switched to battery power, independent from the state of SW_EN1 and SW_EN2. In sleep mode, the charge pumps stop operation, and a separate 100- μ A LDO in each converter supplies the output voltage.

Feature Description (continued)

7.3.5 Power Good

The power good signal is provided by an open drain output. The status of this pin depends on the status of the power good comparators for Vout2, Vout3, and Vout4. Only the converters that are enabled determine the status of the power good signal. If the output voltage of all converter that are enabled, is within its limits, the power good signal goes high. The open drain output is pulled high using an external resistor to 5.5-V maximum. If all converters are disabled, power good is held low. There is a power good delay of 3.1-ms minimum after the voltage of all power rails that are enabled rose above their power good threshold.

7.3.6 Undervoltage Lockout

The undervoltage lockout circuit shuts down the device when the voltage on VIN drops below a typical threshold of 2.9 V. This prevents the device and application from damage. The UVLO circuit allows the device to start up again after the voltage on the VIN pin increased by about 80 mV.

7.3.7 Short Circuit and Overtemperature Protection

The current at the different outputs are limited. When the junction temperature exceeds 155°C, the device shuts down to protect the device from damage. After the temperature decreased to about 135°C, the device starts up if it is still enabled. To reduce the quiescent current, the overtemperature protection is disabled in sleep mode.

7.3.8 TEST Input $\overline{\text{SRP}}$ Enable

The TEST input $\overline{\text{SRP}}$ enable pin has two functions. The pin is an output when the device is in test mode or an input in normal mode.

To test the electrical connections between the power supply chip (TPS65030) and the USB-OTG transceiver (TUSB6010), a test mode is available on TPS65030. The TEST pin is used as an output to TUSB6010. This test mode is entered when EN_SW1 and EN_SW2 and SLEEP are high at the same time. In this case the actual function of SLEEP is disabled and the output pin TEST is changed from high-impedance state to low in case that EN1=1. For all other conditions of EN_SW1, EN_SW2, SLEEP, and EN1 it stays in high-impedance state, see [Table 2](#).

The test mode must be entered with the following sequence:

1. Set SLEEP = 0
2. Set EN1 = 0
3. Make sure Vbus is not supplied from external source ($V_{\text{bus}} < 4.3 \text{ V}$)
4. Set SW_EN1 = SW_EN2 = 1
5. Set SLEEP = 1 (this enters the test mode)
6. Toggle EN1 to switch between low and high impedance on TEST output pin

Table 2. Interconnection Test Mode

EN_SW1	EN_SW2	SLEEP	EN1	TEST
0	0	0	0	High impedance
0	0	0	1	High impedance
0	0	1	0	High impedance
0	0	1	1	High impedance
0	1	0	0	High impedance
0	1	0	1	High impedance
0	1	1	0	High impedance
0	1	1	1	High impedance
1	0	0	0	High impedance
1	0	0	1	High impedance
1	0	1	0	High impedance
1	0	1	1	High impedance
1	1	0	0	High impedance
1	1	0	1	High impedance
1	1	1	0	High impedance
1	1	1	1	0

The principle is also shown in [Figure 7](#).

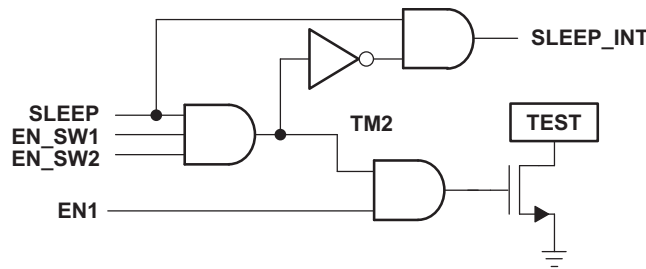

Figure 7. TEST Input, SRP Enable

When the device is in normal mode (not in test mode), the pin is used as an input to enable or disable the SRP feature of the Vbus charge pump. If the TEST $\overline{\text{SRP}}$ pin is held low, the SRP feature is enabled and the charge pump starts up with a current limit of 1 mA until the voltage at Vbus reaches 2.5 V. If the voltage exceeds 2.5 V, the current limit is increased to a higher value in order to provide 100 mA of output current. If $\overline{\text{SRP}}$ is pulled high, the charge pump starts with a higher current limit even for Vbus < 2.5 V in order to provide enough output current to start into a 100-mA load.

7.4 Device Functional Modes

7.4.1 Operating Modes

The TPS65030 contains three charge pumps and one LDO. The charge pumps for Vout2 and Vout3 as well as the LDO, used to generate Vout4, can either operate in normal mode or in sleep mode. See [Sleep](#) for details.

The charge pumps operate in the LinSkip mode. This mode allows to switch seamlessly from the power saving pulse skip mode at light loads, to the low-noise, constant frequency linear-regulation mode, once the output current exceeds the device-specific output current threshold. This output current at which the device switches between these two operating modes is called skip current limit. In order to provide a good efficiency over a wide load range, the skip current limit is set to approximately 25% of the nominal output current for each converter. If the output current drops below the skip current threshold, the device begins to skip switching cycles which reduces its switching frequency and associated switching losses.

Device Functional Modes (continued)

7.4.2 Charge Pump Operation (Based on Vout3 Step-Down Converter)

The description of how the charge pumps operate is based on the design of the step-down charge pump used for Vout3. This converter either operates in a LDO mode for input voltages (battery voltage) lower than 3.5 V. If the input voltage exceeds 3.5 V, the converter operates as a step-down charge pump. As the efficiency of a charge pump mainly depends on the input, output voltage ratio and its operating mode (LDO or x1/2), the efficiency graph shows a typical sawtooth waveform. This is caused by the fact that the charge pump can only increase efficiency if it switches to a different operating mode but not by adjusting its duty cycle like in inductive converters, where the efficiency curve is smooth.

7.4.3 LDO Conversion Mode

In the LDO mode the flying capacitor is not used for transferring energy. The switches 3 and 4 are closed and connect the input directly with the output. This mode is automatically selected if the input voltage is too low to provide enough output voltage in x1/2 charge pump mode. In LDO mode, the regulation of the current is done through switch 4. For an output current of less than 20 mA, the current through switch is turned on and off like in SKIP mode regulation.

7.4.4 X1/2 Conversion Mode

This conversion mode is internally selected if the input to output voltage ratio is greater than 2. As illustrated in Figure 8, in the first switching cycle, the flying capacitor is charged in series with the output capacitor. In the second cycle the flying capacitor is connected in parallel with the output capacitor which discharges the flying capacitor and charges the output. Regulation is done similar to LDO mode by regulating the current through switch 4. For an output current less than the SKIP current threshold, switch 4 does not turn on each switching cycle unless energy is needed at the output. The device now operates in skip mode with a lower switching frequency, depending on the load current.

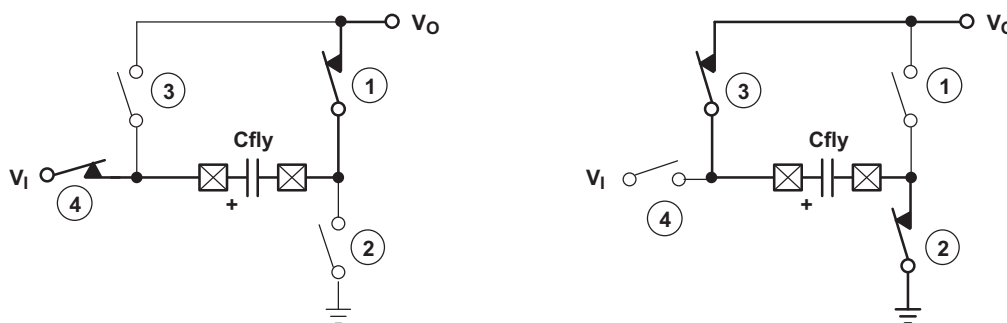

Figure 8. Conversion Mode

7.4.5 X2 Conversion Mode

This conversion mode applies to the converter used to generate Vout2. It is used to generate an output voltage that is higher than the input voltage. In the first switching cycle, the flying capacitor is charged in parallel to the input voltage. In the second switching cycle, the flying capacitor is connected in series with the input voltage, charging the output capacitor to twice the input voltage. Regulation of the output voltage is done similar to the other conversion modes.

7.4.6 Sleep-Mode LDO

In sleep mode, a separate LDO in the charge pump block, supplied from the battery, is used to provide the output voltage.

8 Application and Implementation

NOTE

Information in the following applications sections is not part of the TI component specification, and TI does not warrant its accuracy or completeness. TI's customers are responsible for determining suitability of components for their purposes. Customers should validate and test their design implementation to confirm system functionality.

8.1 Application Information

The TPS65030 is designed for use as a power supply for USB-OTG applications such as cellular phones, smart phones, PDAs, and handheld PCs.

8.2 Typical Application

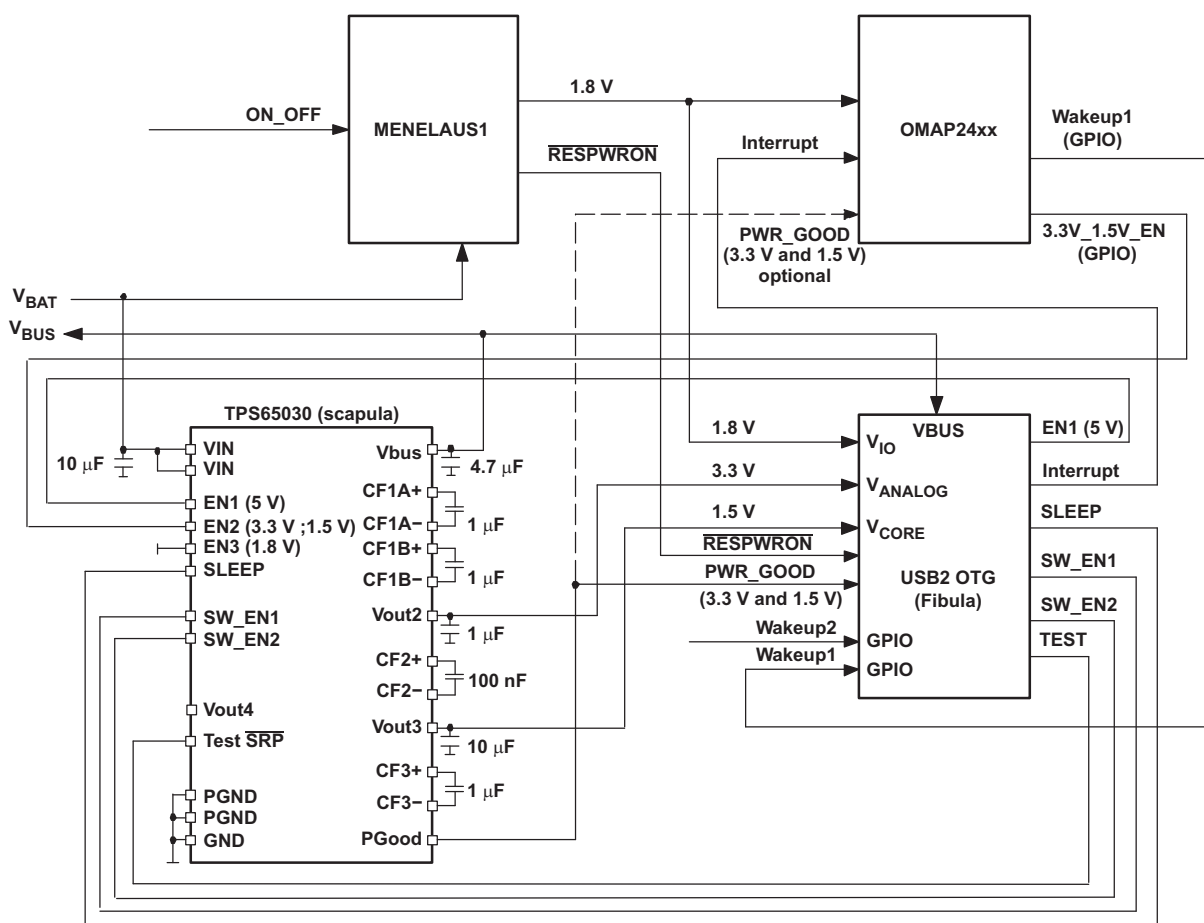

Figure 9. Application Schematic

8.2.1 Design Requirements

For this design example, use the parameters listed in Table 3 as the input parameters.

Table 3. Design Parameters

DESIGN PARAMETER	EXAMPLE VALUE
Operating input voltage range	3 V to 5 V
Switching frequency	1 MHz

8.2.2 Detailed Design Procedure

8.2.2.1 Capacitor Selection

Ceramic capacitors such as X5R or X7R are recommended to be used with TPS65030. Low ESR capacitors on VOUTx reduce the ripple voltage on the output of the supplies. [Table 4](#) lists capacitor types that have been tested with the TPS65030. For the flying capacitors, the value is not critical. For values lower than those listed in the recommended table, the performance of the converter decreases with regard to maximum output current at minimum input voltage. It also causes the converter to switch to its lower efficient mode at a higher input voltage. The value of the output capacitors is critical for stability. A high DC-bias voltage at ceramic capacitors causes a lower capacitance than expected. This effect is critical for Vbus with an output voltage of 5 V. The Vbus converter is designed to operate with a minimum capacitance of 3 μF . In order to keep the minimum capacitance at Vbus above 3 μF , a voltage rating for Cout1 of more than 6.3 V may be required, depending on the specification given by its manufacturer.

Table 4. Capacitors

PART	VALUE	VOLTAGE	MANUFACTURER	SIZE	NOTES
C1005X5R1A104K	100 nF	10 V	TDK	0402	
C1608X5R1A105M	1 μF	10 V	TDK	0603	
C2012X5R1A475M	4.7 μF	10 V	TDK	0805	For Vbus
C2012X5R0J106M	10 μF	6.3 V	TDK	0805	

The voltage rating on the flying capacitors is listed in [Table 5](#).

Table 5. Voltage Ratings

REFERENCE	VALUE	VOLTAGE ACROSS FLYING CAPACITOR	RECOMMENDED VOLTAGE RATING
CF1A, CF1B	1 μF	VIN	6.3 V
CF2	100 nF	Vout2	4 V
CF3	1 μF	Vout3	4 V

Due to aging and DC bias effect, the minimum value of real capacitors when these are minimum size, may be lower than the initial design goals for TPS65030. Therefore TPS65030 has been verified by simulations to be fully functional and stable with the worst case values for the capacitors given in the table below. Due to the low capacitance, the output ripple voltage and transient voltage have a different value compared to the capacitors listed in [Recommended Operating Conditions](#). These values are additionally given in [Electrical Characteristics](#).

Table 6. Minimum Capacitor Values For Operation

		MIN	MAX	UNIT
C _I	Input capacitance	8		μF
C _{O1}	Output capacitance at Vbus; for V _I \leq 4.2 V	2		μF
C _{O2}	Output capacitance at Vout2	0.58		μF
C _{O3}	Output capacitance at Vout3	8		μF
C _{O4}	Output capacitance at Vout4	0.8		μF
	Capacitance for flying capacitor, CF1A, CF1B, V _I min > 3.05 V to support an output current of 100 mA	0.52		μF
	Capacitance for flying capacitor CF3	0.7		μF
	Capacitance for flying capacitor CF2	0.077		μF

8.2.3 Application Curves

$V_I = 3.7\text{ V}$, $T_A = 25^\circ\text{C}$, Sleep = low

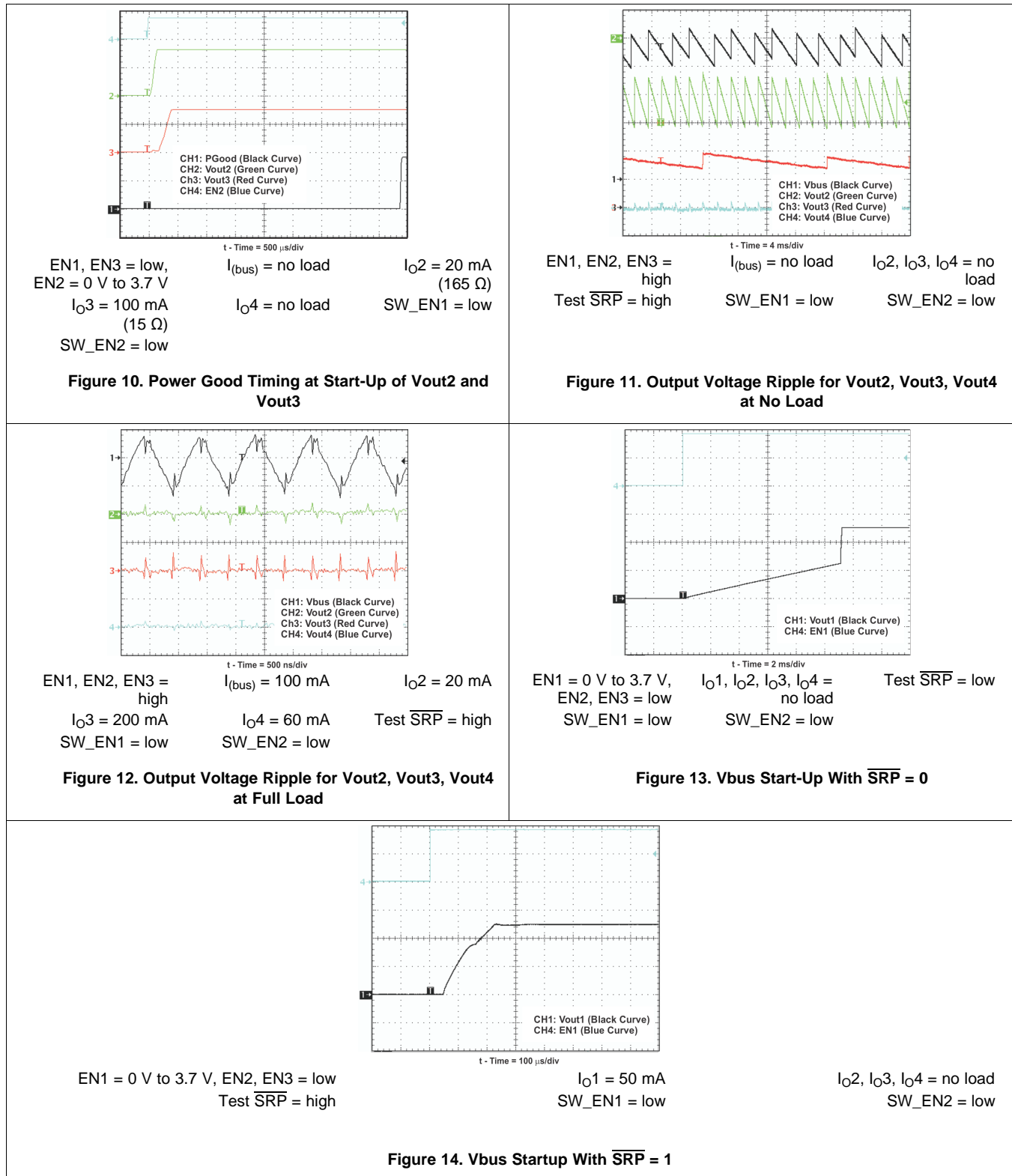

$V_I = 3.1\text{ V}$, $T_A = 25^\circ\text{C}$, Sleep = low

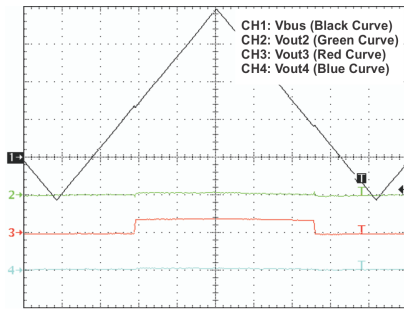

t - Time = 10 ms/div
 EN1 = low, EN2, EN3 = high, $V_{bus} = 4\text{ V to } 5\text{ V to } 4\text{ V}$, $I_{O2} = 20\text{ mA}$ (165 Ω)
 $I_{O3} = 200\text{ mA}$ (7.5 Ω), $I_{O4} = 60\text{ mA}$ (30 Ω), Test $\overline{\text{SRP}} = \text{high}$
 SW_EN1 = high, SW_EN2 = high

Figure 15. Output Voltage Ripple for Vout2, Vout3, Vout4 During Vbus Switching

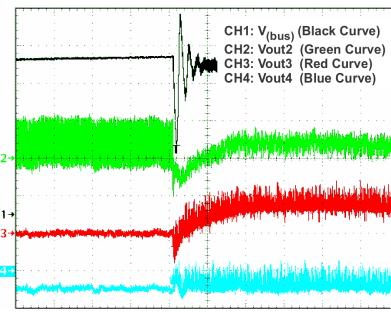

t - Time = 40 $\mu\text{s}/\text{div}$
 EN1 = low, EN2, EN3 = high, $V_{bus} = 4\text{ V to } 5\text{ V}$, $I_{O2} = 20\text{ mA}$ (165 Ω)
 $I_{O3} = 200\text{ mA}$ (7.5 Ω), $I_{O4} = 60\text{ mA}$ (30 Ω), Test $\overline{\text{SRP}} = \text{high}$
 SW_EN1 = high, SW_EN2 = high

Figure 16. Output Voltage Ripple for Vout2, Vout3, Vout4 During V_I to Vbus Switching

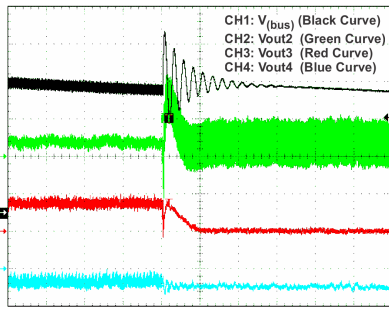

t - Time = 100 $\mu\text{s}/\text{div}$
 EN1 = low, EN2, EN3 = high, $V_{bus} = 5\text{ V to } 4\text{ V}$, $I_{O2} = 20\text{ mA}$ (165 Ω)
 $I_{O3} = 200\text{ mA}$ (7.5 Ω), $I_{O4} = 60\text{ mA}$ (30 Ω), Test $\overline{\text{SRP}} = \text{high}$
 SW_EN1 = high, SW_EN2 = high

Figure 17. Output Voltage of Vout2, Vout3, Vout4 During Vbus to V_I Switching

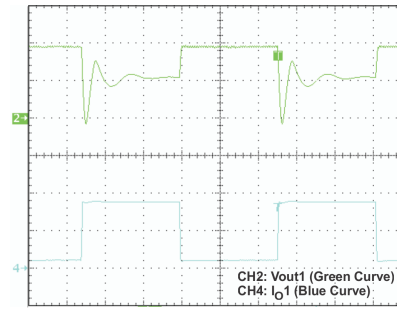

t - Time = 200 $\mu\text{s}/\text{div}$
 EN1 = high, EN2, EN3 = low, $I_{(bus)} = 10\text{ mA to } 90\text{ mA}$, $I_{O2}, I_{O3}, I_{O4} = \text{no load}$
 Test $\overline{\text{SRP}} = \text{high}$, SW_EN1 = low, SW_EN2 = low

Figure 18. Load Transient Response for Vbus

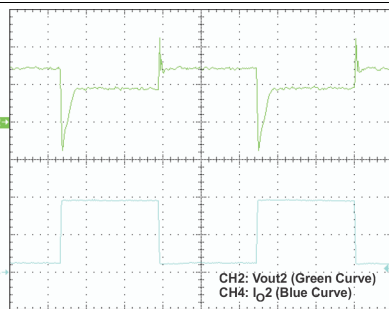

t - Time = 200 $\mu\text{s}/\text{div}$
 EN2 = high, EN1, EN3 = low, $I_{(bus)} = \text{no load}$, $I_{O2} = 2\text{ mA to } 20\text{ mA}$
 $I_{O3}, I_{O4} = \text{no load}$, Test $\overline{\text{SRP}} = \text{high}$, SW_EN1 = low
 SW_EN2 = low

Figure 19. Load Transient Response for Vout2

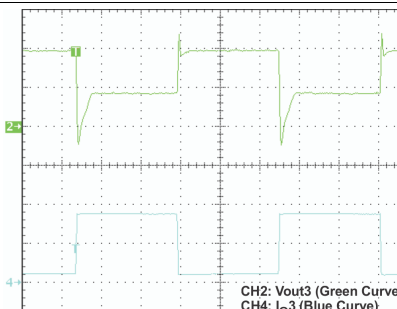

t - Time = 200 $\mu\text{s}/\text{div}$
 EN2 = high, EN1, EN3 = low, $V_{bus} = \text{no load}$, $V_{out2}, V_{out4} = \text{no load}$
 $V_{out3} = 20\text{ mA to } 180\text{ mA}$, Test $\overline{\text{SRP}} = \text{high}$, SW_EN1 = low
 SW_EN2 = low

Figure 20. Load Transient Response for Vout3

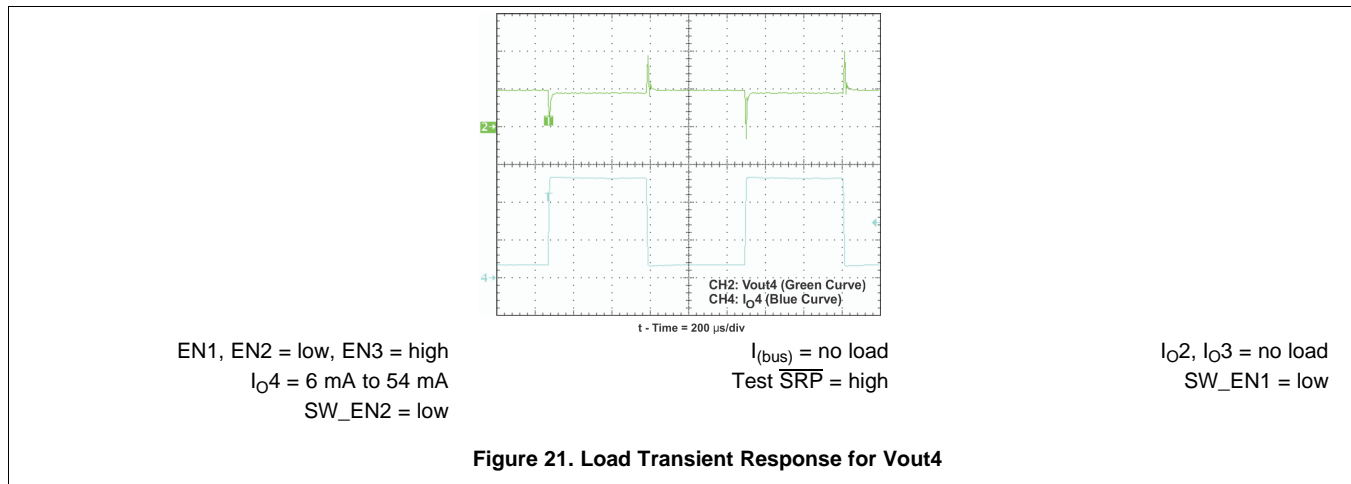

9 Power Supply Recommendations

9.1 Power Dissipation

In normal operation when the battery voltage is at its nominal value of 3.8 V, the TPS65030 has very low-power dissipation as it is optimized for operation with one Li-ion cell. If all outputs are fully loaded, the internal-power dissipation is about 300 mW at $V_1 = 3.8$ V. The measurements were taken with decreasing battery voltage similar to a real battery-powered system.

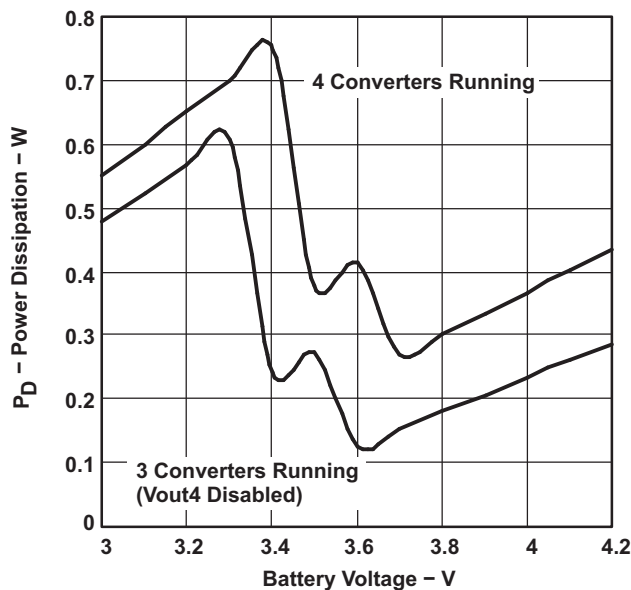

Figure 22. Power Dissipation vs Battery Voltage

Typically, the TUSB6010 requires less than the full supply current specified for the TPS65030. [Figure 23](#) shows the power dissipation with the typical current required by TUSB6010. V_{bus} is loaded with 100 mA, Vout2 is loaded with 20 mA and Vout3 is loaded with 100 mA.

Power Dissipation (continued)

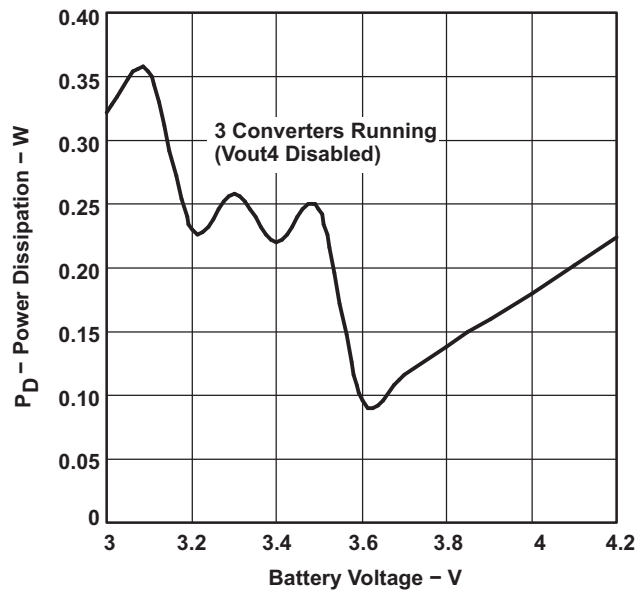

Figure 23. Power Dissipation vs Battery Voltage

10 Layout

10.1 Layout Guidelines

All capacitors must be soldered as close as possible to the IC. A PCB layout proposal for a four-layer board is shown in Figure 24. Care must be taken to connect all capacitors as close as possible to the circuit to achieve optimized output voltage ripple performance. All critical connections like power input and output pins and the pins for the flying capacitors are located on the outside of the package. Signal connections like enable signals are located in the inside and can be routed on the bottom layer or on a signal layer. Power connections must be routed on the layer where the device is placed. A GND plane must be used for optimal performance of the device.

10.2 Layout Example

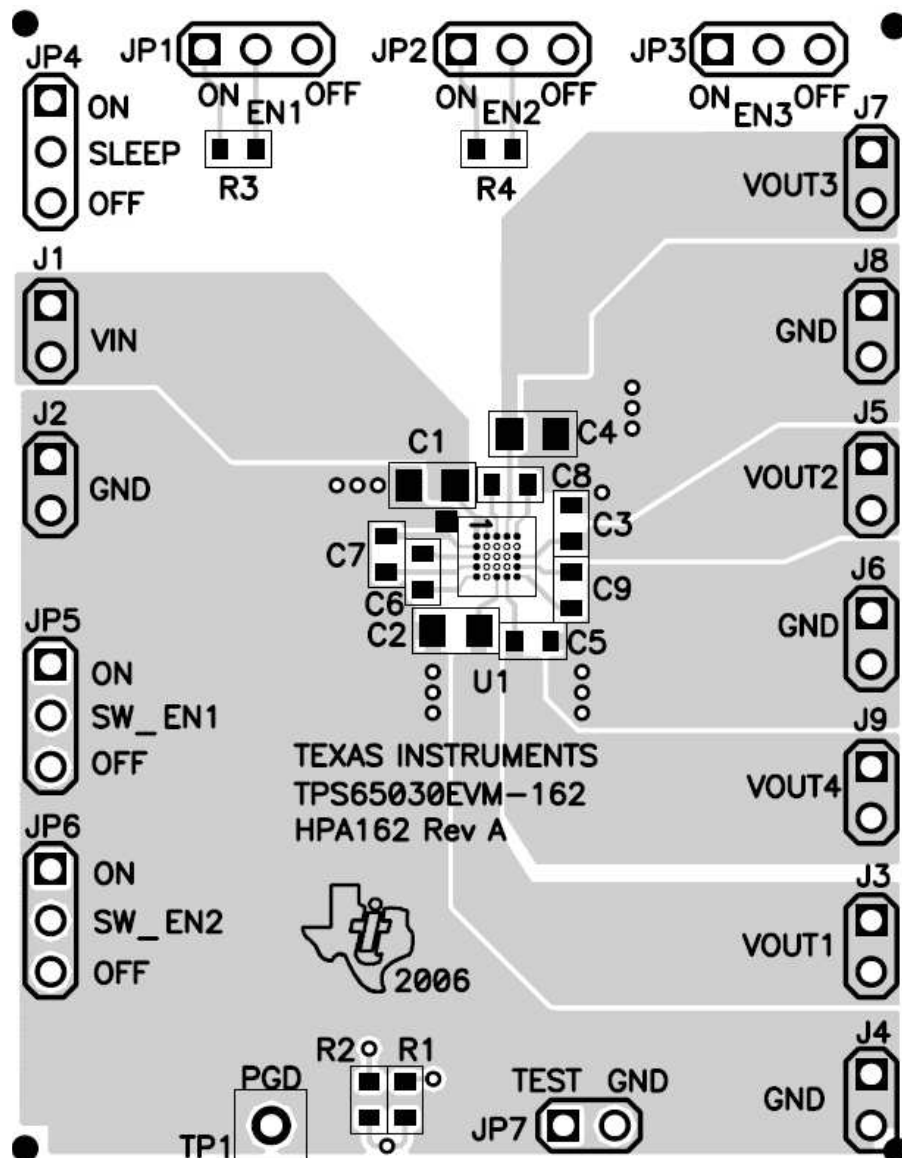

Figure 24. Layout Recommendation

11 Device and Documentation Support

11.1 Device Support

11.1.1 Third-Party Products Disclaimer

TI'S PUBLICATION OF INFORMATION REGARDING THIRD-PARTY PRODUCTS OR SERVICES DOES NOT CONSTITUTE AN ENDORSEMENT REGARDING THE SUITABILITY OF SUCH PRODUCTS OR SERVICES OR A WARRANTY, REPRESENTATION OR ENDORSEMENT OF SUCH PRODUCTS OR SERVICES, EITHER ALONE OR IN COMBINATION WITH ANY TI PRODUCT OR SERVICE.

11.2 Community Resources

The following links connect to TI community resources. Linked contents are provided "AS IS" by the respective contributors. They do not constitute TI specifications and do not necessarily reflect TI's views; see TI's [Terms of Use](#).

TI E2E™ Online Community *TI's Engineer-to-Engineer (E2E) Community*. Created to foster collaboration among engineers. At [e2e.ti.com](#), you can ask questions, share knowledge, explore ideas and help solve problems with fellow engineers.

Design Support *TI's Design Support* Quickly find helpful E2E forums along with design support tools and contact information for technical support.

11.3 Trademarks

E2E is a trademark of Texas Instruments.
All other trademarks are the property of their respective owners.

11.4 Electrostatic Discharge Caution



These devices have limited built-in ESD protection. The leads should be shorted together or the device placed in conductive foam during storage or handling to prevent electrostatic damage to the MOS gates.

11.5 Glossary

[SLYZ022](#) — *TI Glossary*.

This glossary lists and explains terms, acronyms, and definitions.

12 Mechanical, Packaging, and Orderable Information

The following pages include mechanical, packaging, and orderable information. This information is the most current data available for the designated devices. This data is subject to change without notice and revision of this document. For browser-based versions of this data sheet, refer to the left-hand navigation.

PACKAGING INFORMATION

Orderable Device	Status (1)	Package Type	Package Drawing	Pins	Package Qty	Eco Plan (2)	Lead/Ball Finish	MSL Peak Temp (3)	Op Temp (°C)	Top-Side Markings (4)	Samples
TPS65030YZKR	ACTIVE	DSBGA	YZK	25	3000	Green (RoHS & no Sb/Br)	SNAGCU	Level-1-260C-UNLIM	-40 to 85	PJMI 2050D4	Samples
TPS65030YZKT	ACTIVE	DSBGA	YZK	25	250	Green (RoHS & no Sb/Br)	SNAGCU	Level-1-260C-UNLIM	-40 to 85	PJMI	Samples

(1) The marketing status values are defined as follows:

ACTIVE: Product device recommended for new designs.

LIFEBUY: TI has announced that the device will be discontinued, and a lifetime-buy period is in effect.

NRND: Not recommended for new designs. Device is in production to support existing customers, but TI does not recommend using this part in a new design.

PREVIEW: Device has been announced but is not in production. Samples may or may not be available.

OBSOLETE: TI has discontinued the production of the device.

(2) Eco Plan - The planned eco-friendly classification: Pb-Free (RoHS), Pb-Free (RoHS Exempt), or Green (RoHS & no Sb/Br) - please check <http://www.ti.com/productcontent> for the latest availability information and additional product content details.

TBD: The Pb-Free/Green conversion plan has not been defined.

Pb-Free (RoHS): TI's terms "Lead-Free" or "Pb-Free" mean semiconductor products that are compatible with the current RoHS requirements for all 6 substances, including the requirement that lead not exceed 0.1% by weight in homogeneous materials. Where designed to be soldered at high temperatures, TI Pb-Free products are suitable for use in specified lead-free processes.

Pb-Free (RoHS Exempt): This component has a RoHS exemption for either 1) lead-based flip-chip solder bumps used between the die and package, or 2) lead-based die adhesive used between the die and leadframe. The component is otherwise considered Pb-Free (RoHS compatible) as defined above.

Green (RoHS & no Sb/Br): TI defines "Green" to mean Pb-Free (RoHS compatible), and free of Bromine (Br) and Antimony (Sb) based flame retardants (Br or Sb do not exceed 0.1% by weight in homogeneous material)

(3) MSL, Peak Temp. -- The Moisture Sensitivity Level rating according to the JEDEC industry standard classifications, and peak solder temperature.

(4) Multiple Top-Side Markings will be inside parentheses. Only one Top-Side Marking contained in parentheses and separated by a "~" will appear on a device. If a line is indented then it is a continuation of the previous line and the two combined represent the entire Top-Side Marking for that device.

Important Information and Disclaimer: The information provided on this page represents TI's knowledge and belief as of the date that it is provided. TI bases its knowledge and belief on information provided by third parties, and makes no representation or warranty as to the accuracy of such information. Efforts are underway to better integrate information from third parties. TI has taken and continues to take reasonable steps to provide representative and accurate information but may not have conducted destructive testing or chemical analysis on incoming materials and chemicals. TI and TI suppliers consider certain information to be proprietary, and thus CAS numbers and other limited information may not be available for release.

In no event shall TI's liability arising out of such information exceed the total purchase price of the TI part(s) at issue in this document sold by TI to Customer on an annual basis.

TAPE AND REEL INFORMATION

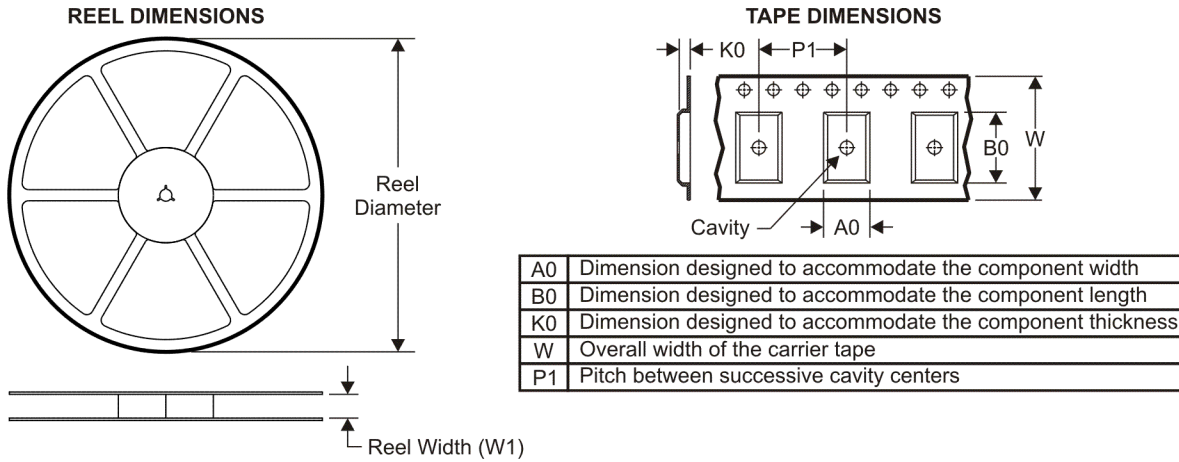

QUADRANT ASSIGNMENTS FOR PIN 1 ORIENTATION IN TAPE

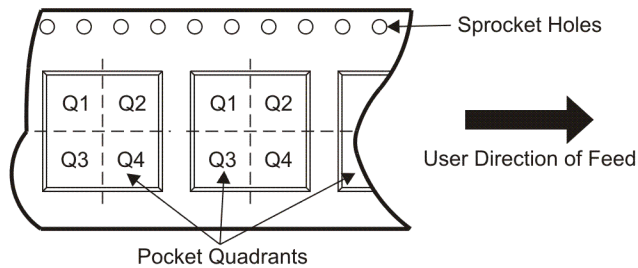

*All dimensions are nominal

Device	Package Type	Package Drawing	Pins	SPQ	Reel Diameter (mm)	Reel Width W1 (mm)	A0 (mm)	B0 (mm)	K0 (mm)	P1 (mm)	W (mm)	Pin1 Quadrant
TPS65030YZKR	DSBGA	YZK	25	3000	180.0	8.4	2.6	2.8	0.81	4.0	8.0	Q1
TPS65030YZKT	DSBGA	YZK	25	250	180.0	8.4	2.6	2.8	0.81	4.0	8.0	Q1

TAPE AND REEL BOX DIMENSIONS

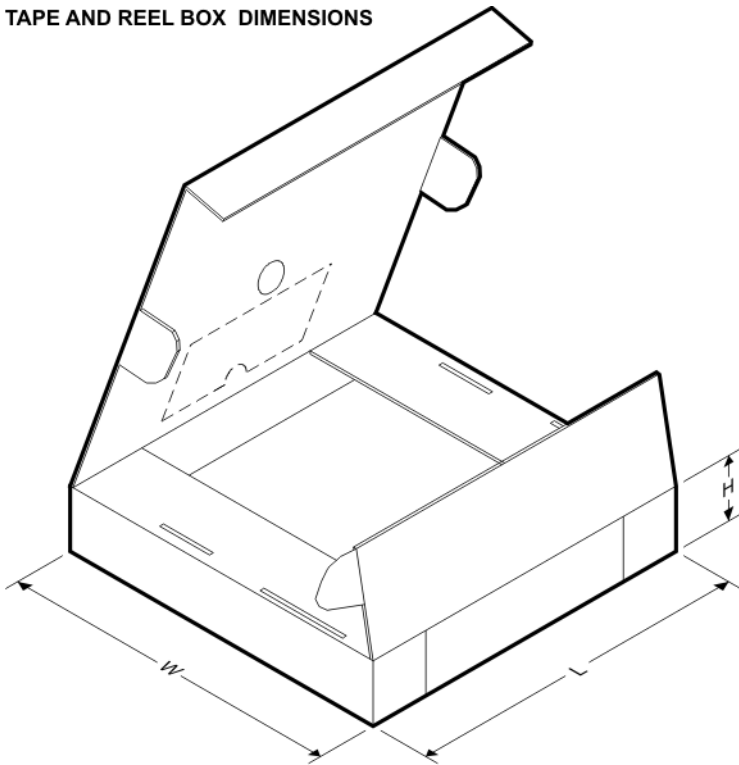

*All dimensions are nominal

Device	Package Type	Package Drawing	Pins	SPQ	Length (mm)	Width (mm)	Height (mm)
TPS65030YZKR	DSBGA	YZK	25	3000	220.0	220.0	34.0
TPS65030YZKT	DSBGA	YZK	25	250	220.0	220.0	34.0

YZK (S-XBGA-N25)

DIE-SIZE BALL GRID ARRAY

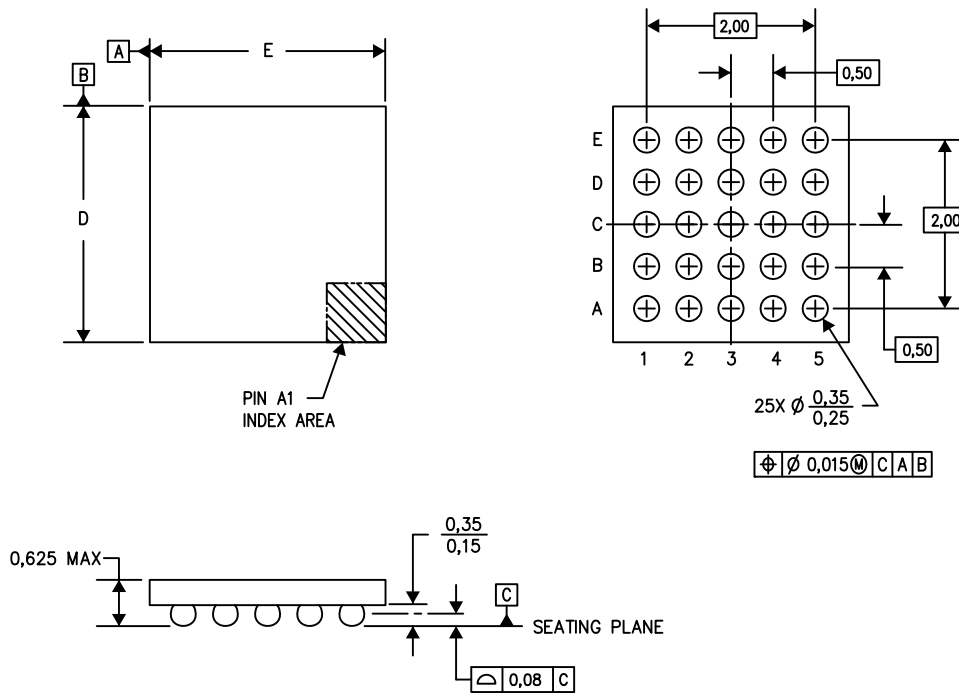

D: Max = 2.698 mm, Min = 2.638 mm

E: Max = 2.5 mm, Min = 2.44 mm

4205062-3/F 07/13

- NOTES:
- A. All linear dimensions are in millimeters. Dimensioning and tolerancing per ASME Y14.5M-1994.
 - B. This drawing is subject to change without notice.
 - C. NanoFree™ package configuration.

NanoFree is a trademark of Texas Instruments.

IMPORTANT NOTICE

Texas Instruments Incorporated and its subsidiaries (TI) reserve the right to make corrections, enhancements, improvements and other changes to its semiconductor products and services per JESD46, latest issue, and to discontinue any product or service per JESD48, latest issue. Buyers should obtain the latest relevant information before placing orders and should verify that such information is current and complete. All semiconductor products (also referred to herein as "components") are sold subject to TI's terms and conditions of sale supplied at the time of order acknowledgment.

TI warrants performance of its components to the specifications applicable at the time of sale, in accordance with the warranty in TI's terms and conditions of sale of semiconductor products. Testing and other quality control techniques are used to the extent TI deems necessary to support this warranty. Except where mandated by applicable law, testing of all parameters of each component is not necessarily performed.

TI assumes no liability for applications assistance or the design of Buyers' products. Buyers are responsible for their products and applications using TI components. To minimize the risks associated with Buyers' products and applications, Buyers should provide adequate design and operating safeguards.

TI does not warrant or represent that any license, either express or implied, is granted under any patent right, copyright, mask work right, or other intellectual property right relating to any combination, machine, or process in which TI components or services are used. Information published by TI regarding third-party products or services does not constitute a license to use such products or services or a warranty or endorsement thereof. Use of such information may require a license from a third party under the patents or other intellectual property of the third party, or a license from TI under the patents or other intellectual property of TI.

Reproduction of significant portions of TI information in TI data books or data sheets is permissible only if reproduction is without alteration and is accompanied by all associated warranties, conditions, limitations, and notices. TI is not responsible or liable for such altered documentation. Information of third parties may be subject to additional restrictions.

Resale of TI components or services with statements different from or beyond the parameters stated by TI for that component or service voids all express and any implied warranties for the associated TI component or service and is an unfair and deceptive business practice. TI is not responsible or liable for any such statements.

Buyer acknowledges and agrees that it is solely responsible for compliance with all legal, regulatory and safety-related requirements concerning its products, and any use of TI components in its applications, notwithstanding any applications-related information or support that may be provided by TI. Buyer represents and agrees that it has all the necessary expertise to create and implement safeguards which anticipate dangerous consequences of failures, monitor failures and their consequences, lessen the likelihood of failures that might cause harm and take appropriate remedial actions. Buyer will fully indemnify TI and its representatives against any damages arising out of the use of any TI components in safety-critical applications.

In some cases, TI components may be promoted specifically to facilitate safety-related applications. With such components, TI's goal is to help enable customers to design and create their own end-product solutions that meet applicable functional safety standards and requirements. Nonetheless, such components are subject to these terms.

No TI components are authorized for use in FDA Class III (or similar life-critical medical equipment) unless authorized officers of the parties have executed a special agreement specifically governing such use.

Only those TI components which TI has specifically designated as military grade or "enhanced plastic" are designed and intended for use in military/aerospace applications or environments. Buyer acknowledges and agrees that any military or aerospace use of TI components which have **not** been so designated is solely at the Buyer's risk, and that Buyer is solely responsible for compliance with all legal and regulatory requirements in connection with such use.

TI has specifically designated certain components as meeting ISO/TS16949 requirements, mainly for automotive use. In any case of use of non-designated products, TI will not be responsible for any failure to meet ISO/TS16949.

Products

Audio	www.ti.com/audio
Amplifiers	amplifier.ti.com
Data Converters	dataconverter.ti.com
DLP® Products	www.dlp.com
DSP	dsp.ti.com
Clocks and Timers	www.ti.com/clocks
Interface	interface.ti.com
Logic	logic.ti.com
Power Mgmt	power.ti.com
Microcontrollers	microcontroller.ti.com
RFID	www.ti-rfid.com
OMAP Applications Processors	www.ti.com/omap
Wireless Connectivity	www.ti.com/wirelessconnectivity

Applications

Automotive and Transportation	www.ti.com/automotive
Communications and Telecom	www.ti.com/communications
Computers and Peripherals	www.ti.com/computers
Consumer Electronics	www.ti.com/consumer-apps
Energy and Lighting	www.ti.com/energy
Industrial	www.ti.com/industrial
Medical	www.ti.com/medical
Security	www.ti.com/security
Space, Avionics and Defense	www.ti.com/space-avionics-defense
Video and Imaging	www.ti.com/video

TI E2E Community

e2e.ti.com

Looking for pricing, stock, or lifecycle information?

Click below to explore more details on WIN SOURCE:

 [View TPS65030EVM-162 on WIN SOURCE](#)

 [Texas Instruments](#) Information

Optimize Your Supply Chain with WIN SOURCE Solutions

-  Global Sourcing Solution
-  Obsolete Management
-  Cost Control Management
-  Shortage Management
-  Alternative Solution
-  Excess Inventory Management