



**THE DATASHEET OF  
RT8487GJ6**



## High Efficiency BCM LED Driver Controller for High Power Factor Offline Applications

### General Description

The RT8487 is a Boundary mode high PF floating buck constant LED current output controller with an internal gate driver.

The RT8487 features a ZCS detector which keeps system operating in BCM and obtaining excellent power efficiency, better EMI performance.

The RT8487 achieves high power factor correction (PFC) and low total harmonic distortion of current (THDi) by a smart internal line voltage compensation circuit which has minimized system component counts; saved both PCB size and total system cost.

Especially, the RT8487 can use a cheap simple drum core inductor in the system instead of an EE core to obtain high efficiency.

The RT8487 is housed in a TSOT-23-6 package. Thus, the components in the whole LED driver system can be made very compact.

### Ordering Information

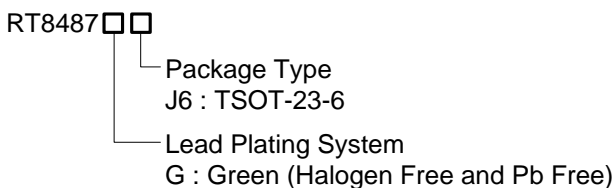

Note :

Richtek products are :

- ▶ RoHS compliant and compatible with the current requirements of IPC/JEDEC J-STD-020.
- ▶ Suitable for use in SnPb or Pb-free soldering processes.

### Marking Information

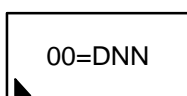

00= : Product Code  
DNN : Date Code

### Features

- Support High Power Factor and THDi Consideration Applications
- Programmable Constant LED Current with Highly Precision Current Regulation
- Extremely Low Quiescent Current Consumption and 1μA Shutdown Current
- True Low System BOM Cost and Economical Floating Buck Converter Solution
- Unique Programmable AND Pin for ZVS Setting to Achieve Best Power Efficiency
- Universal Input Voltage Range with Off-Line Topology
- Built-in Over Thermal Protection
- Built-in Over Voltage Protection
- Output LED String Open Protection
- Output LED String Short Protection
- Output LED String Over Current Protection

### Applications

- E27, PAR, Light Bar, Offline LED Lights

### Pin Configurations

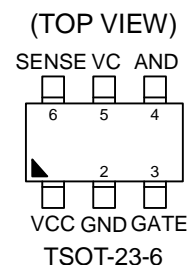

## Simplified Application Circuit

Buck type:

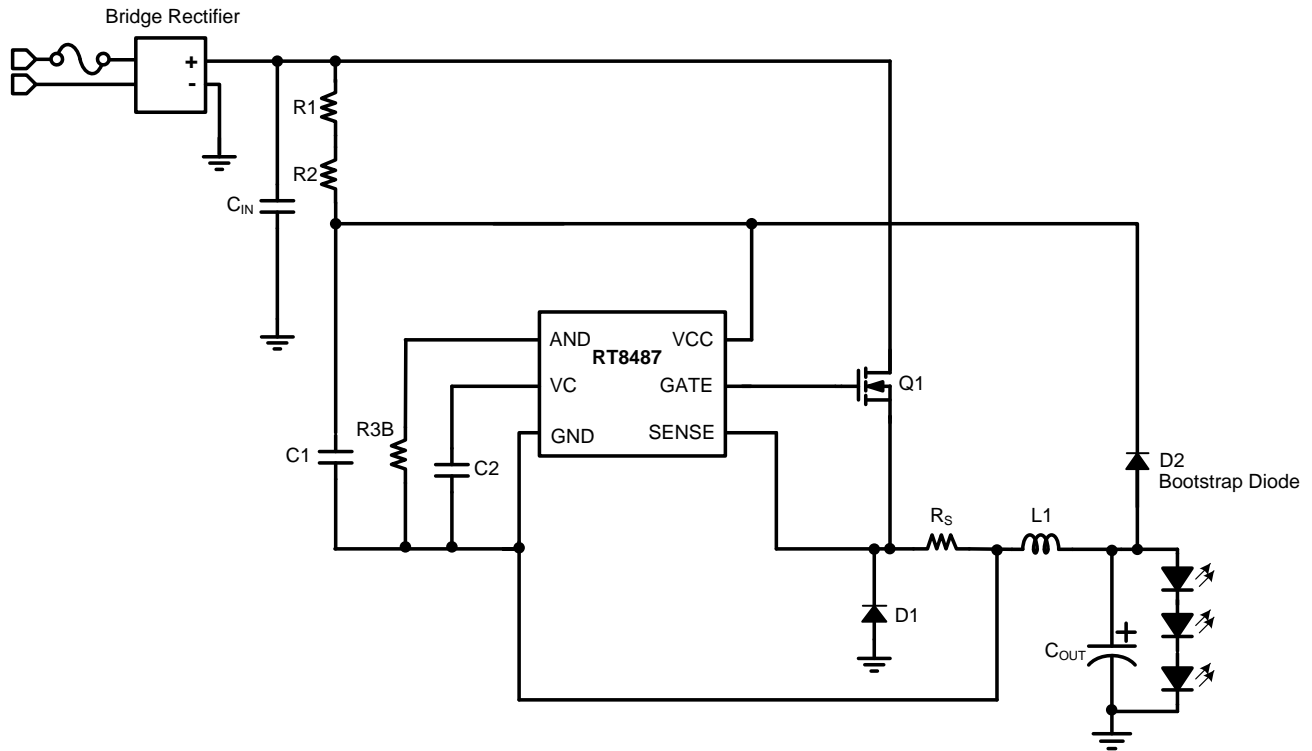

**Functional Pin Description**

Pin No.	Pin Name	Pin Function
1	VCC	Supply Voltage Input. For good bypass, a ceramic capacitor near the VCC pin is required.
2	GND	Ground.
3	GATE	Gate Driver Output for External MOSFET Switch.
4	AND	AND Function Pin.
5	VC	Close Loop Compensation Node.
6	SENSE	LED Current Sense Input. The typical sensing threshold is 250mV between the SENSE and GND pin.

**Function Block Diagram**

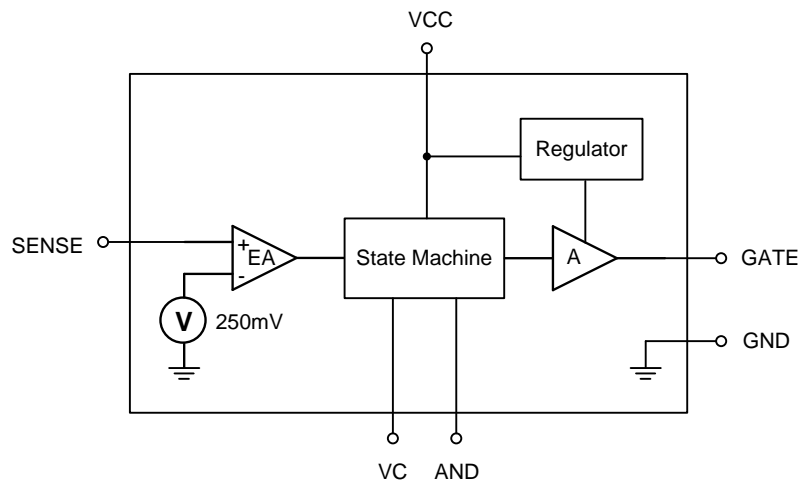

**Operation**

The RT8487 senses true average output current and keeps the system driving constant output current. The VC pin is the compensation node in this close loop system and dominates the frequency response. To stabilize the system and achieve better PFC / THDi, proper selection of a compensation network is needed.

**Absolute Maximum Ratings** (Note 1)

- Supply Input Voltage (VCC) ----- 40V
- Power Dissipation, P<sub>D</sub> @ T<sub>A</sub> = 25°C  
 TSOT-23-6 ----- 0.5W
- Package Thermal Resistance (Note 2)  
 TSOT-23-6, θ<sub>JA</sub> ----- 197.4°C/W
- Lead Temperature (Soldering, 10 sec.)----- 260°C
- Junction Temperature ----- 150°C
- Storage Temperature Range ----- -65°C to 150°C
- ESD Susceptibility (Note 3)  
 HBM (Human Body Model) -----2kV  
 MM (Machine Model) -----200V

**Recommended Operating Conditions** (Note 4)

- Supply Input Voltage, VCC ----- 10V to 30V
- Ambient Temperature Range----- -40°C to 85°C
- Junction Temperature Range ----- -40°C to 125°C

**Electrical Characteristics**

(V<sub>CC</sub> = 24V, T<sub>A</sub> = 25°C, unless otherwise specified)

Parameter	Symbol	Test Conditions	Min	Typ	Max	Unit
VCC UVLO ON	V <sub>UVLO_ON</sub>		17	18	19	V
VCC UVLO OFF	V <sub>UVLO_OFF</sub>		6.4	7.2	8	V
VCC Shutdown Current	I <sub>SD</sub>	V <sub>CC</sub> = V <sub>UVLO_ON</sub> - 3V	--	--	1	μA
VCC Quiescent Current	I <sub>QC</sub>	Gate stands still	--	0.5	5	mA
VCC Operating Current	I <sub>CC</sub>	By C <sub>GATE</sub> = 1nF, Freq.= 20kHz	--	1	5	mA
VCC OVP Level	V <sub>OVP</sub>		--	34	--	V
Sense Pin Leakage Current	I <sub>SENSE</sub>	V <sub>SENSE</sub> = 3V	--	1	5	μA
Current Sense Threshold	V <sub>SENSE</sub>		242.5	250	257.5	mV
AND Pin Leakage Current	I <sub>AND</sub>	V <sub>AND</sub> = 5V	--	1	2	μA
GATE Voltage High	V <sub>GATE_H</sub>	I <sub>GATE</sub> = 0mA	10.5	12	--	V
		I <sub>GATE</sub> = 10mA	9	10	--	
GATE Driver	Rising Time	t <sub>r</sub>	--	50	--	ns
	Falling Time	t <sub>f</sub>	--	25	--	

**Note 1.** Stresses beyond those listed “Absolute Maximum Ratings” may cause permanent damage to the device. These are stress ratings only, and functional operation of the device at these or any other conditions beyond those indicated in the operational sections of the specifications is not implied. Exposure to absolute maximum rating conditions may affect device reliability

**Note 2.** θ<sub>JA</sub> is measured at T<sub>A</sub> = 25°C on a high effective thermal conductivity four-layer test board per JEDEC 51-7.

**Note 3.** Devices are ESD sensitive. Handling precaution recommended.

**Note 4.** The device is not guaranteed to function outside its operating conditions.

**Typical Application Circuit**

Buck :

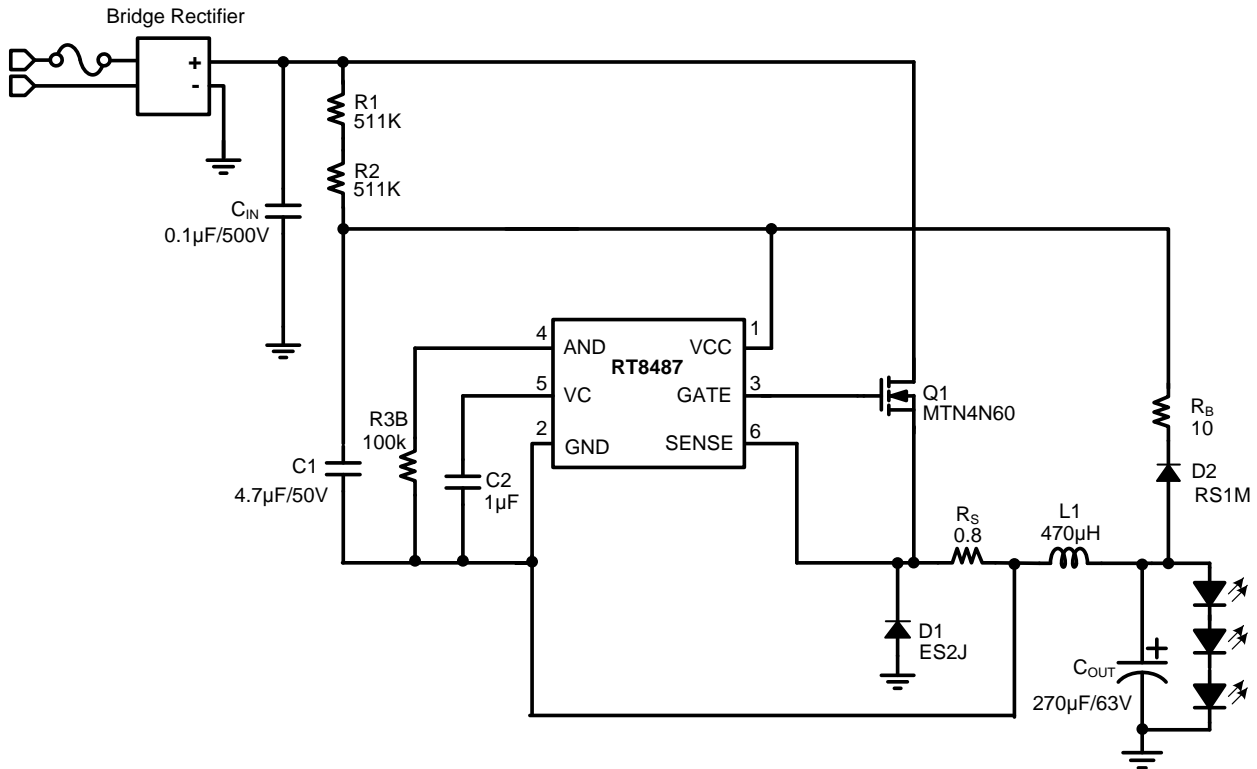

Typical Operating Characteristics

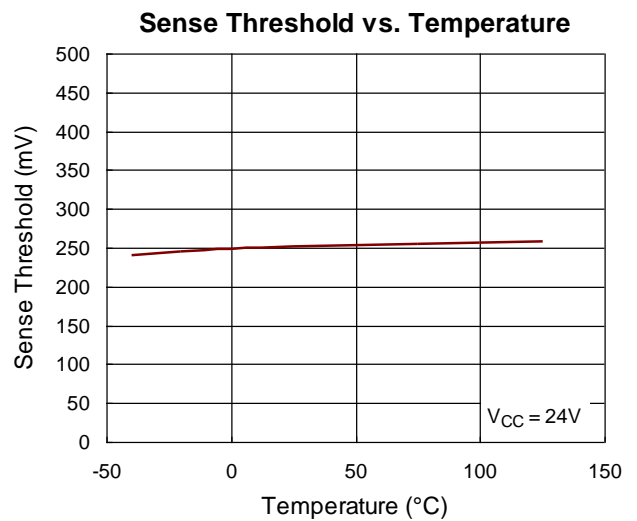
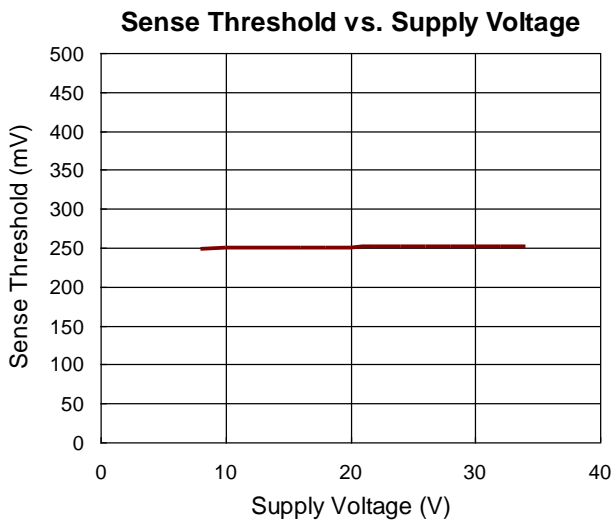
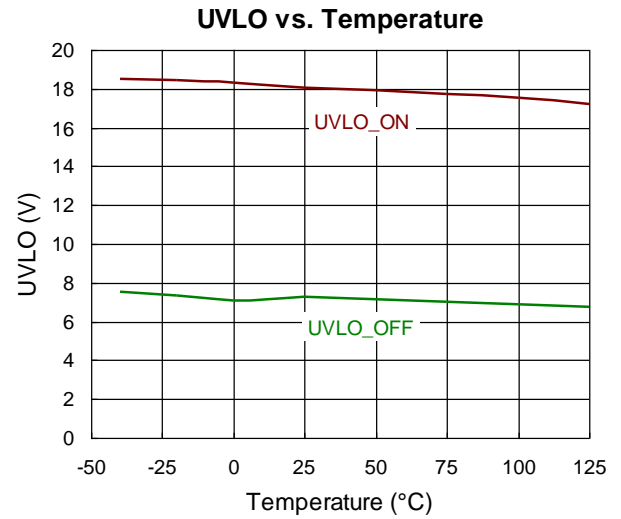
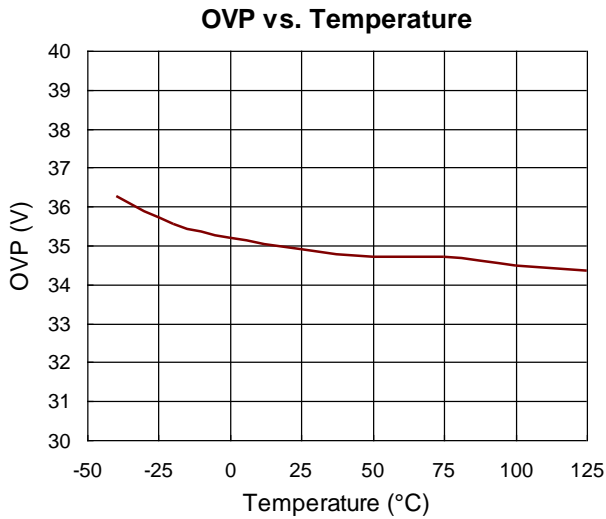
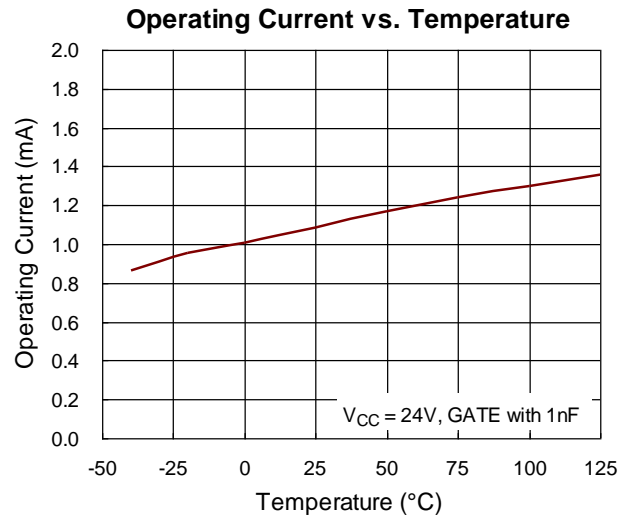
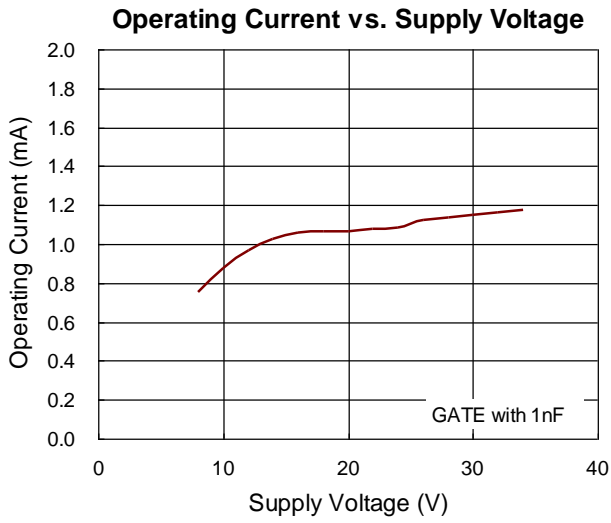

**Efficiency vs. Input Voltage**

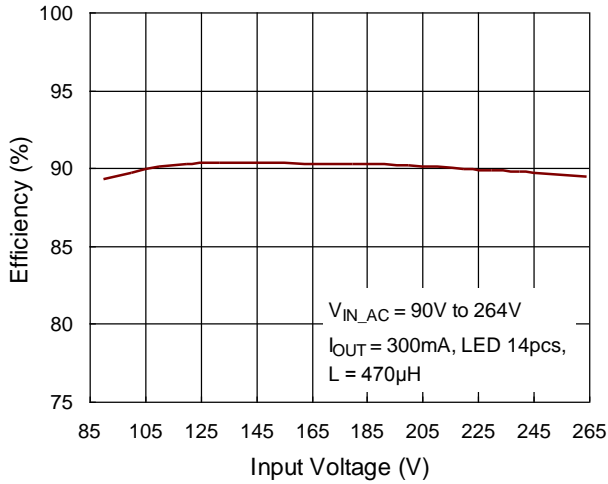

**Output Current vs. Input Voltage**

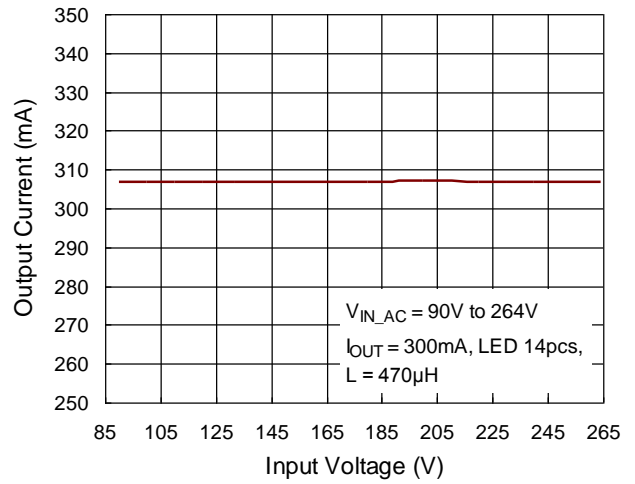

**Power Factor vs. Input Voltage**

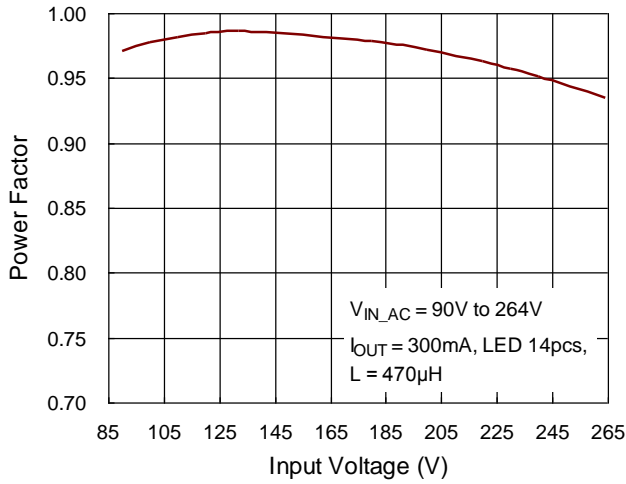

**Input and Output Current**

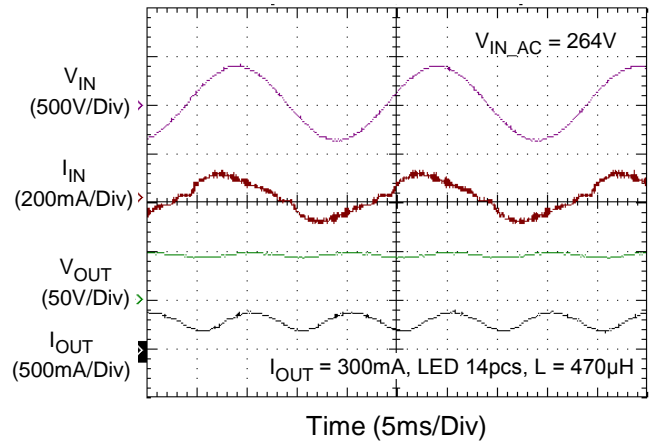

**Power On**

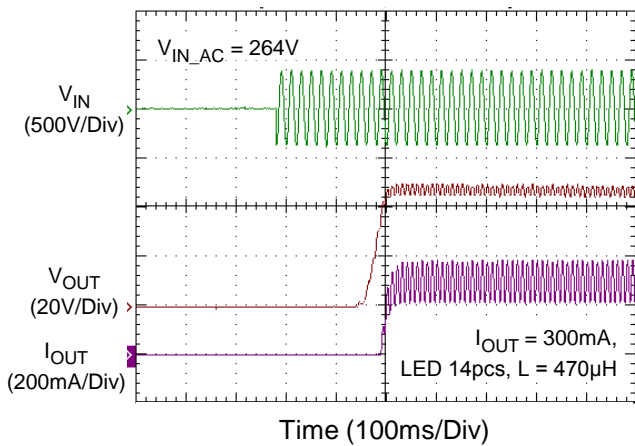

**Power Off**

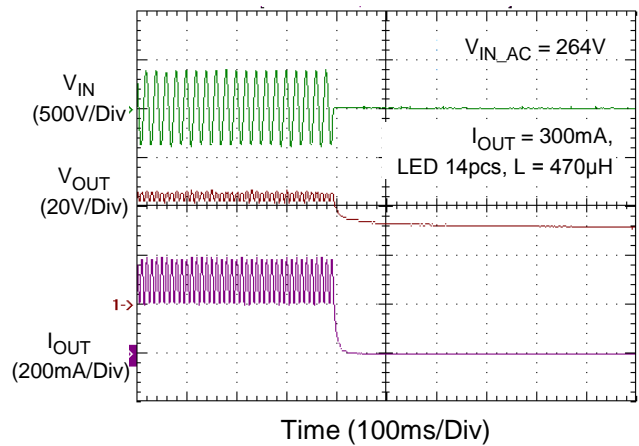

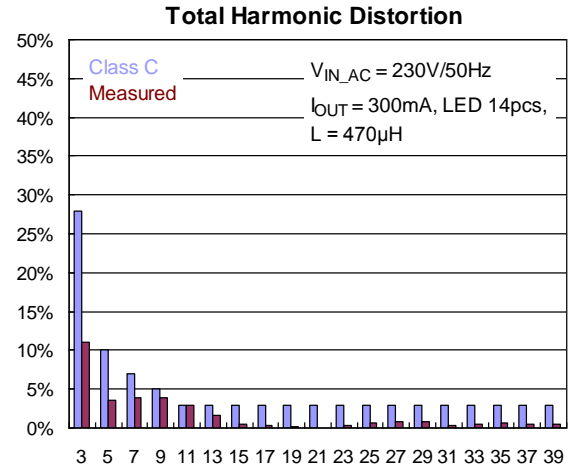
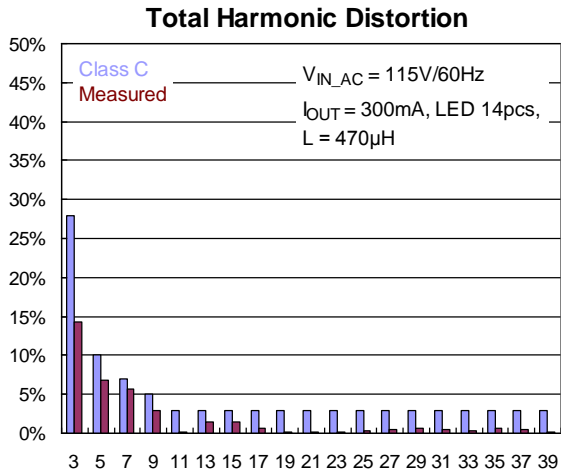

**Application Information**

RT8487 is a boundary mode, high efficiency constant current controller with internal high side driver, which can be used in buck and buck-boost configuration, to provide a constant output current to the (LED) load. It contains special circuitry for achieving high power factor and low input current THD, while minimizing external component count. The small SOT23-6 package keeps application footprint small, and makes RT8487 a cost effective solution for off-line LED drivers.

The RT8487 can achieve high accuracy LED output current via the average current feedback loop control. The internal sense voltage (250mV typ.) is used to set the average output current. The average current is set by the external resistor, RS. The sense voltage is also used for over current protection(OCP) function. The typical OCP threshold is about seven times of the sense voltage threshold.

**Under Voltage Lockout (UVLO)**

The RT8487 includes a UVLO function with 10.8V hysteresis.

For system start up, the VIN must rise over 18V (typ.) to turn on the GATE terminal.

The GATE terminal will turn off if VIN falls below 7.2V (typ.)

**Setting Average Output Current**

The output current that flows through the LED string is set by an external resistor, RS, which is connected between

the GND and SENSE pins. The relationship between output current, IOUT, and RS is shown below :

$$I_{OUT} = \frac{250}{R_S}(\text{mA})$$

**Start-Up Resistor**

The start-up resistor should be chosen to set the start

up current exceeds certain minimum value. Otherwise, the RT8487 may latch off and the system will never start. The start-up current equals  $(\sqrt{2} \times 90V) / (R1 + R2)$  (for 110VAC regions), and equals  $(\sqrt{2} \times 180V) / (R1 + R2)$  (for 220VAC regions). The typical required minimum start-up current is 100μA. The typical total start up resistance (R1 + R2) is around 1M Ohm for universal inputs.

**Input Diode Bridge Rectifier Selection**

The current rating of the input bridge rectifier is dependent on the VOUT /VIN conversion ratio and out LED current. The voltage rating of the input bridge rectifier, VBR, on the other hand, is only dependent on the input voltage. Thus, the VBR rating is calculated as below :

$$V_{BR} = 1.2 \times (\sqrt{2} \times V_{AC(MAX)})$$

where VAC(MAX) is the maximum input voltage (RMS) and the parameter 1.2 is used for safety margin.

For this example :

$$V_{BR} = 1.2 \times (\sqrt{2} \times V_{AC(MAX)}) = (1.2 \times \sqrt{2} \times 264) = 448V$$

If the input source is universal, VBR will reach 448V. In this case, a 600V, 0.5A bridge rectifier can be chosen.

**Input Capacitor Selection**

For High Power Factor application, the input Capacitor CIN should use a small value capacitance to achieve line voltage sine-wave.

The voltage rating of the input filter capacitor, VVIN, should be large enough to handle the input voltage.

$$V_{IN} \geq 1.2 \times (\sqrt{2} \times V_{AC(MAX)}) = (1.2 \times \sqrt{2} \times 264) = 448V$$

Thus, a 0.1μF / 500V film capacitor can be chosen in this case.

### Inductor Selection

For high power factor application, the RT8487 operates the converter in BCM (Boundary-Condition Mode). The inductance range is defined by peak current of inductor, maximum and minimum value of switching on time and off time, for ensuring the inductor operates in BCM. The peak current of inductor is showed as below :

$$I_{PEAK} = \frac{2P_{in}}{V_{PEAK}F(a)}$$

$$\text{where } a = \frac{V_{OUT}}{V_{PEAK}}$$

and

$$F(a) \approx -0.411a^4 + 0.296a^3 - 0.312a^2 + 0.638a - 0.0000846, \{a|0 \sim 0.7\}$$

The inductance range is showed as below :

$$L = \frac{V_{OUT}T_{OFF}}{I_{PEAK}} = \frac{(V_{PEAK} - V_{OUT})T_{ON}}{I_{PEAK}}$$

Where  $0.5\mu s \leq T_{ON} \leq 35\mu s$  and  $2\mu s \leq T_{OFF} \leq 30\mu s$

The frequency at the top of the sine wave can be calculated :

$$f_{SW} = \frac{1}{T_{ON} + T_{OFF} + T_{DELAY}}$$

( $T_{DELAY}$  is determined by the resistor connected to AND pin, see Turn on delay time)

### Turn On Delay Time

After the inductor current has reached zero, a resonance will occur between the inductor and the MOSFET drain-source capacitance.

In order to minimize the MOSFET switching losses, RT8487 provides the flexibility to adjust the delay time of next switch-on cycle in order to switch-on at the maximum point of the resonance, which corresponds to the minimum drain-source voltage value.

The delay time from zero current point to the maximum of the switch resonance which can be calculated from :

$$T_{resonance} = \pi\sqrt{L1 \times C_{SW}}$$

where  $C_{SW}$  is the capacitance at the switch node, mostly determined by the MOSFET drain-source capacitance.

The delay time  $T_{DELAY}$  from zero current detection point to next MOSFET switch-on cycle can be adjusted by the resistor value R3B connected between AND pin and IC GND

$$T_{DELAY}(\mu s) = (-0.4 \times R3B^2 + 3500 \times R3B + 407500) \times 10^{-6}$$

R3B resistor value in kΩ.

### Forward Diode Selection

When the power switch turns off, the path for the current is through the diode connected between the switch output and ground. This forward biased diode must have minimum voltage drop and recovery time. The reverse voltage rating of the diode should be greater than the maximum input voltage and the current rating should be greater than the maximum load current.

The peak voltage stress of diode is :

$$V_D \geq 1.2 \times (\sqrt{2} \times V_{AC(MAX)}) = 1.2 \times (\sqrt{2} \times 264) = 448V$$

The input source is universal ( $V_{IN} = 85V$  to  $264V$ ),  $V_D$  will reach 448V.

### MOSFET Selection

The peak current through this MOSFET will be over the maximum output current. This component current rating

should be greater than 1.2 times the maximum load current and the reverse voltage rating of the MOSFET should be greater than 1.2 times the maximum input voltage, assuming a  $\pm 20\%$  output current ripple.

The peak voltage rating of the MOSFET is :

$$V_{Q1} = 1.2 \times (\sqrt{2} \times V_{AC(MAX)}) = 1.2 \times (\sqrt{2} \times 264) = 448V$$

The largest peak current will occur at the highest  $V_{IN}$ . The current rating of MOSFET is determined by the

OCP threshold which is about seven times of the sense voltage threshold.

**Thermal Protection (OTP)**

A thermal protection feature is included to protect the RT8487 from excessive heat damage. When the junction temperature exceeds a threshold of 150°C, the thermal protection OTP will be triggered and the GATE will be turned off.

**Thermal Considerations**

For continuous operation, do not exceed absolute maximum junction temperature. The maximum power dissipation depends on the thermal resistance of the IC package, PCB layout, rate of surrounding airflow, and difference between junction and ambient temperature. The maximum power dissipation can be calculated by the following formula :

$$P_{D(MAX)} = (T_{J(MAX)} - T_A) / \theta_{JA}$$

where  $T_{J(MAX)}$  is the maximum junction temperature,  $T_A$  is the ambient temperature, and  $\theta_{JA}$  is the junction to ambient thermal resistance.

For recommended operating condition specifications, the maximum junction temperature is 125°C. The junction to ambient thermal resistance,  $\theta_{JA}$ , is layout dependent. For TSOT-23-6 package, the thermal resistance,  $\theta_{JA}$ , is 197.4°C/W on a standard JEDEC 51-7 four-layer thermal test board. The maximum power dissipation at  $T_A = 25^\circ\text{C}$  can be calculated by the following formula :

$$P_{D(MAX)} = (125^\circ\text{C} - 25^\circ\text{C}) / (197.4^\circ\text{C/W}) = 0.5\text{W for TSOT-23-6 package}$$

The maximum power dissipation depends on the operating ambient temperature for fixed  $T_{J(MAX)}$  and thermal resistance,  $\theta_{JA}$ . The derating curve in Figure 1 allows the designer to see the effect of rising ambient temperature on the maximum power dissipation.

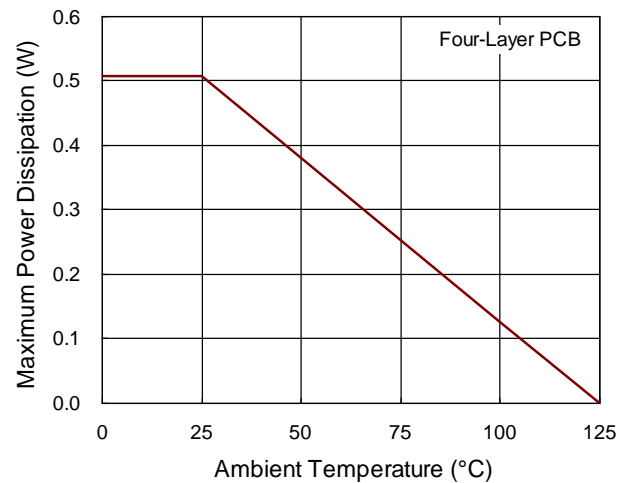

Figure 1. Derating Curve of Maximum Power Dissipation

**Layout Considerations**

For best performance of the RT8487, the following layout guidelines should be strictly followed.

- ▶ The hold up capacitor, C1, must be placed as close as possible to the VCC pin.
- ▶ The compensation capacitor, C2, and delay resistor, R3B, must be placed as close as possible to the VC and the AND pin.
- ▶ The IC GATE and GND pin are high frequency switching nodes. Both traces must be as wide and short as possible.
- ▶ Keep the main traces with switching current as short and wide as possible.
- ▶ Place C<sub>IN</sub>, L1, Q1, R<sub>s</sub>, C<sub>OUT</sub>, and D1 as close to each other as possible.

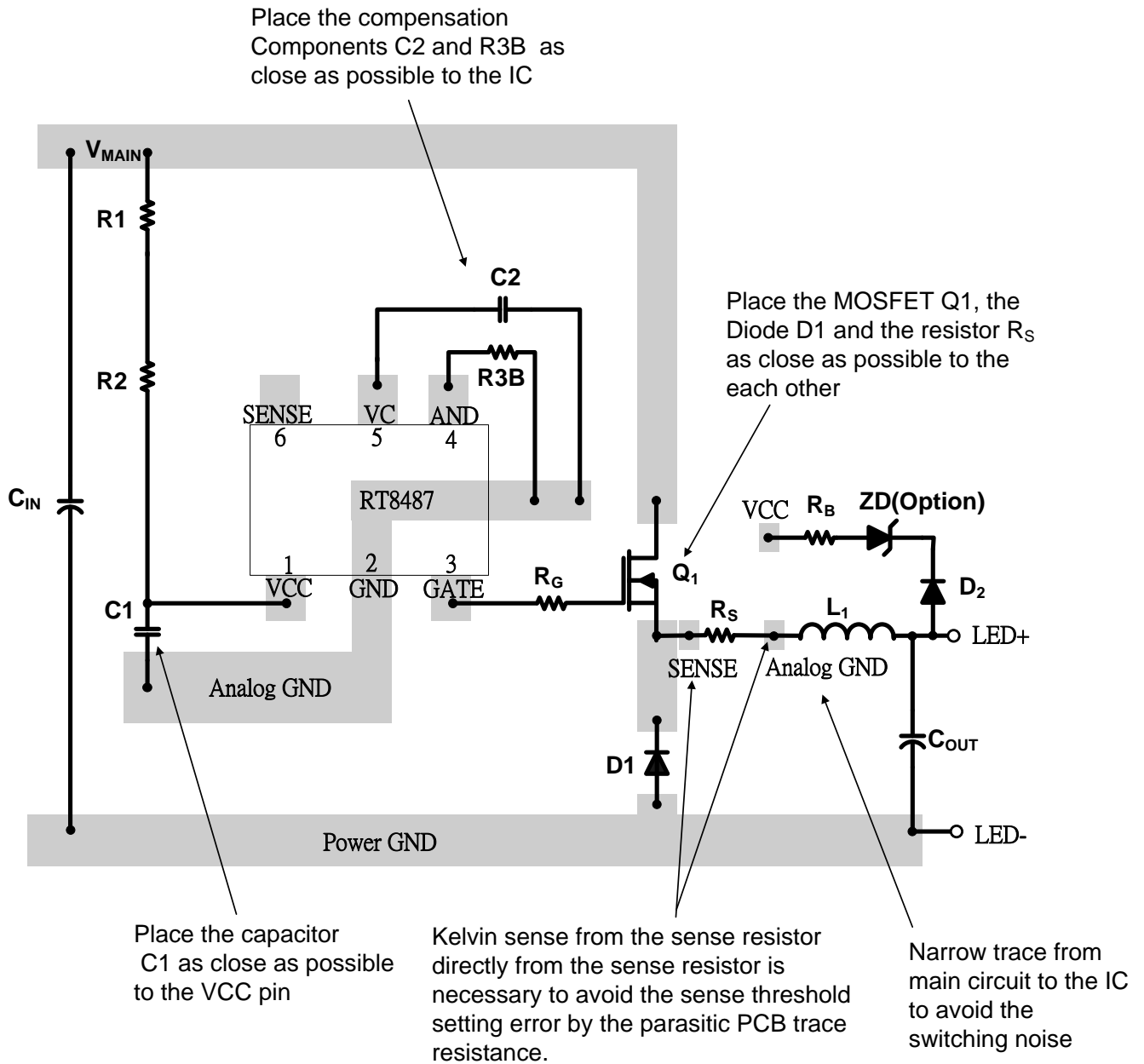
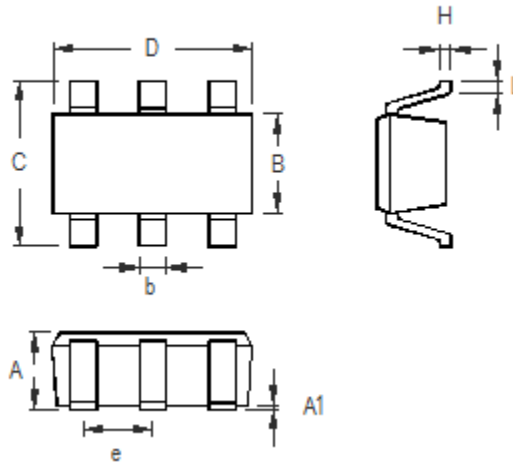

Figure 2. PCB Layout Guide

**Outline Dimension**



Symbol	Dimensions In Millimeters		Dimensions In Inches	
	Min	Max	Min	Max
A	0.700	1.000	0.028	0.039
A1	0.000	0.100	0.000	0.004
B	1.397	1.803	0.055	0.071
b	0.300	0.559	0.012	0.022
C	2.591	3.000	0.102	0.118
D	2.692	3.099	0.106	0.122
e	0.838	1.041	0.033	0.041
H	0.080	0.254	0.003	0.010
L	0.300	0.610	0.012	0.024

**TSOT-23-6 Surface Mount Package**

**Richtek Technology Corporation**

14F, No. 8, Tai Yuen 1<sup>st</sup> Street, Chupei City  
 Hsinchu, Taiwan, R.O.C.  
 Tel: (8863)5526789

Richtek products are sold by description only. Richtek reserves the right to change the circuitry and/or specifications without notice at any time. Customers should obtain the latest relevant information and data sheets before placing orders and should verify that such information is current and complete. Richtek cannot assume responsibility for use of any circuitry other than circuitry entirely embodied in a Richtek product. Information furnished by Richtek is believed to be accurate and reliable. However, no responsibility is assumed by Richtek or its subsidiaries for its use; nor for any infringements of patents or other rights of third parties which may result from its use. No license is granted by implication or otherwise under any patent or patent rights of Richtek or its subsidiaries.

Copyright © 2015 Richtek Technology Corporation. All rights reserved. **RICHTEK** is a registered trademark of Richtek Technology Corporation.

## Looking for pricing, stock, or lifecycle information?

Click below to explore more details on WIN SOURCE:

- [View RT8487GJ6 on WIN SOURCE](#)
- [Richtek USA Inc. Information](#)

## Optimize Your Supply Chain with WIN SOURCE Solutions

- ✓ Global Sourcing Solution
- ✓ Obsolete Management
- ✓ Cost Control Management
- ✓ Shortage Management
- ✓ Alternative Solution
- ✓ Excess Inventory Management