



**THE DATASHEET OF
EVB_RT7302GS**



RT7302 Evaluate Report for T8 Internal Power (Flyback)

*ACDC BU / SLM Division
Mar. 2016*

<http://www.richtek.com/LED>

RICHTEK
your power partner.

RT7302 Brief introduction

RT7302 is an active power factor correction controller specifically designed for using as a constant current LED driver.

Supporting:

Isolation: PSR mode

Non-isolation: Buck-Boost mode

Applications **➔** **AC/DC LED lighting driver**



PAR Lamp



E27 Bulb



T5/T8 Tube

.....

RT7302 Features

Primary-Side Regulation PWM Controller and High PF LED Driver

- Primary Side Regulation(PSR)
- Power Factor Correction(PFC)
- Compatible with TRIAC Dimmer
- Built-in HV start-up Device
- Critical conduction mode(CRM)
- Max/Min switch frequency clamping
- Max/Min on time limitation

RT7302 Advantage

- Universal input voltage. (90Vac~264Vac)
- Good LED current regulation.
- No shunt regulator and photo to achieve the 2nd regulation.
- Protection:
 - a. Open-circuit protection
 - b. Short-circuit protection
 - c. Output diode short-circuit protection
 - d. Vdd under/over voltage protection
 - e. Over temperature protection
 - f. Cycle-by-cycle current limitation
 - g. Excellent PF and THD.

Circuit

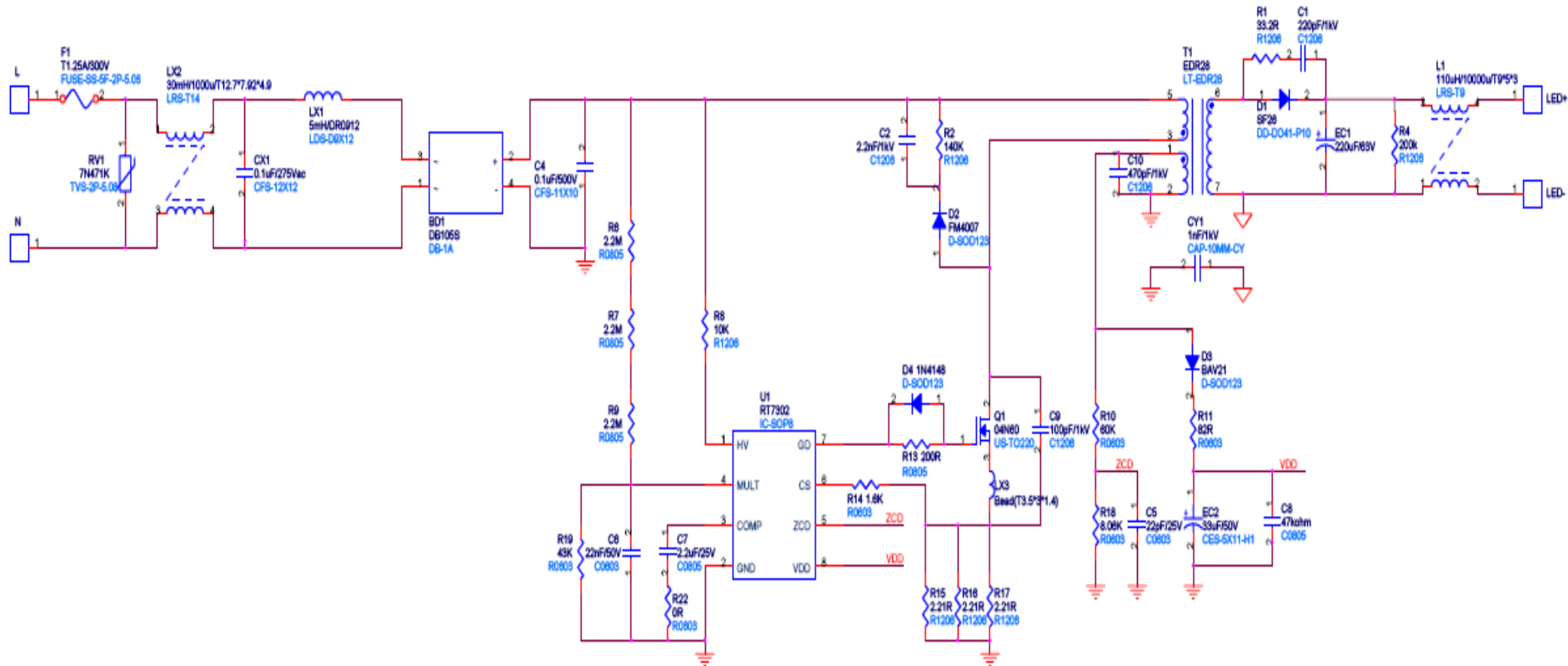

Electrical Performance

Frequency	Vac [V]	Pin [watt]	Vout [V]	Iout [mA]	Pout [Watt]	Eff. [%]	PF Value	THD
60Hz	90	21.54	45.75	405	18.53	86.02%	0.9960	6.37
60Hz	100	21.24	45.78	405	18.54	87.29%	0.9960	6.68
60Hz	110	21.03	45.80	404	18.50	87.98%	0.9954	7.03
60Hz	120	20.87	45.83	403	18.47	88.50%	0.9950	7.24
60Hz	132	20.73	45.86	402	18.44	88.93%	0.9944	7.53
50Hz	180	20.60	46.00	401	18.45	89.54%	0.9908	7.51
50Hz	200	20.60	46.07	400	18.43	89.46%	0.9886	7.02
50Hz	220	20.64	46.15	400	18.46	89.44%	0.9851	6.73
50Hz	230	20.69	46.23	400	18.49	89.38%	0.9832	6.82
50Hz	240	20.75	46.31	400	18.52	89.27%	0.9811	6.99
50Hz	264	20.90	46.44	400	18.58	88.88%	0.9738	7.86

current regulation = 1.23%

△ Efficiency = 3.52%

Maximum PFC = 0.996

Minimum PFC = 0.974

Efficiency

Efficiency

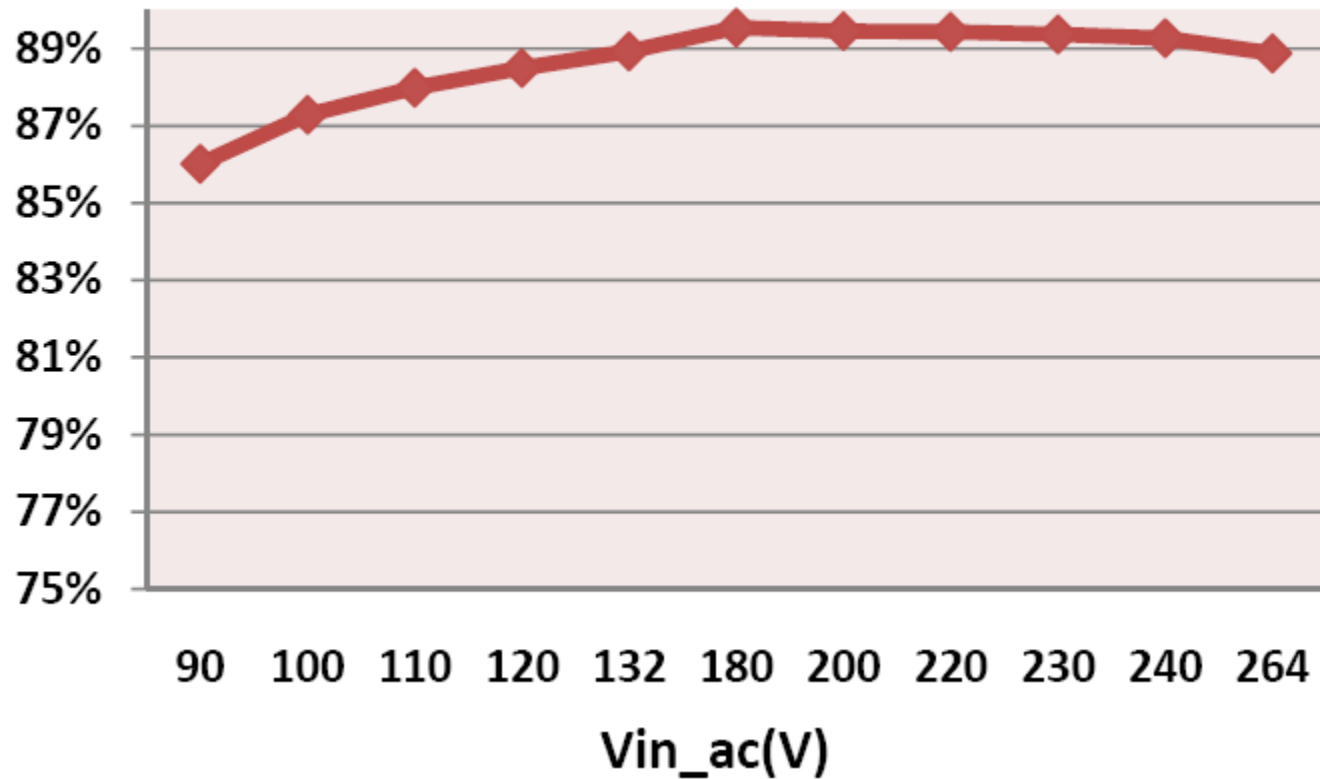

Power Factor

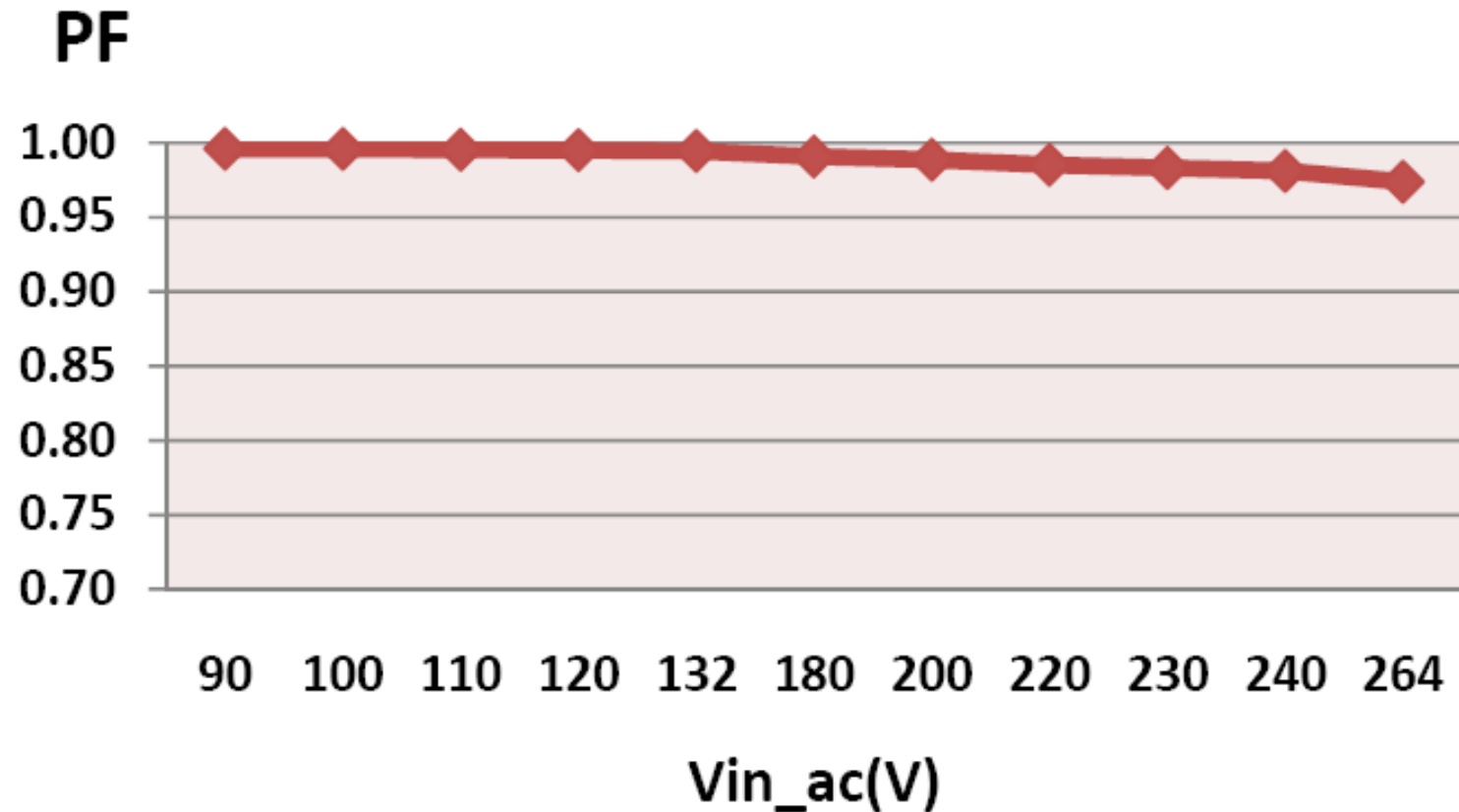

Current regulation

I_{out}(mA)

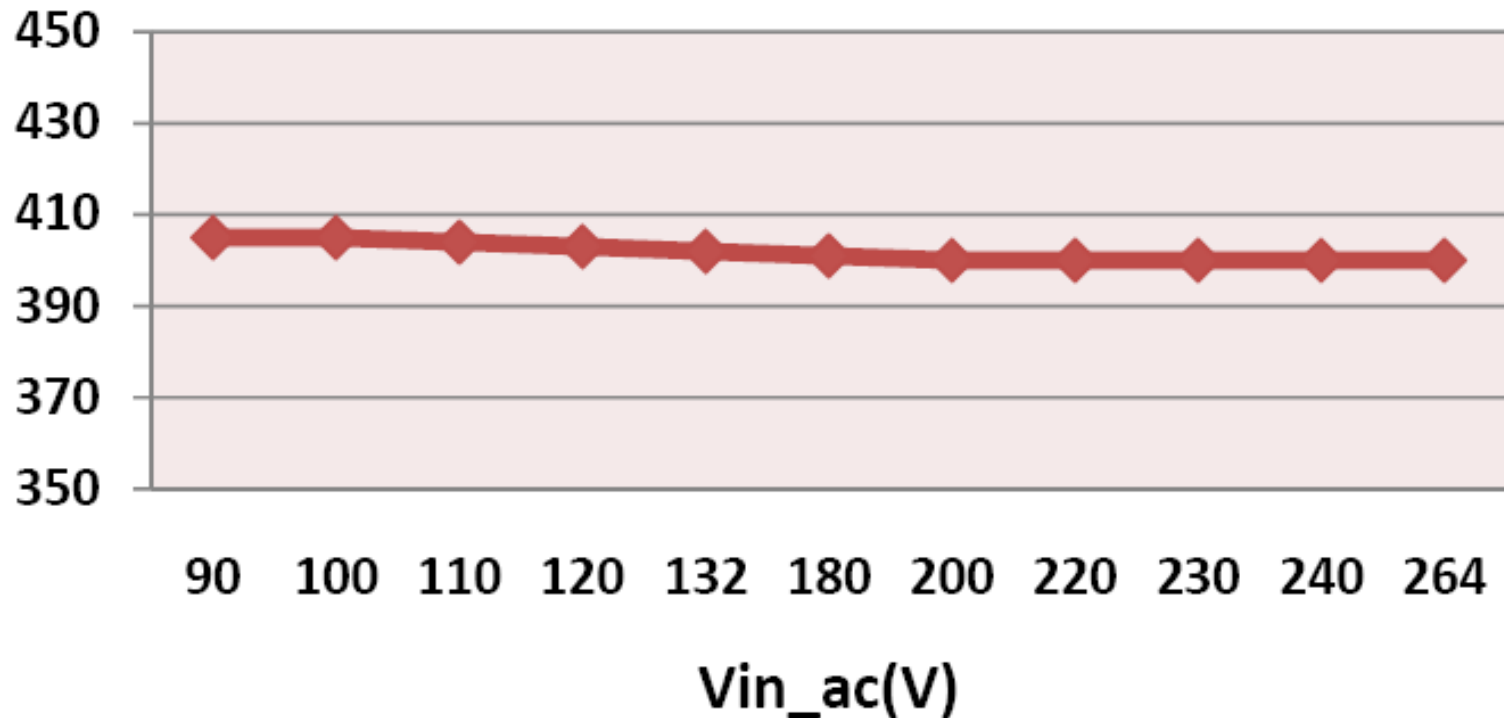

Limit in 1.23%

Load regulation

Frequency	Vac [V]	Vout [V]	Iout [mA]	Load regulation
60Hz	110	42.79	407	0.98%
60Hz	110	45.80	404	
60Hz	110	49.52	403	
50Hz	230	43.11	403	0.99%
50Hz	230	46.23	400	
50Hz	230	49.73	399	

I_{out}(mA)

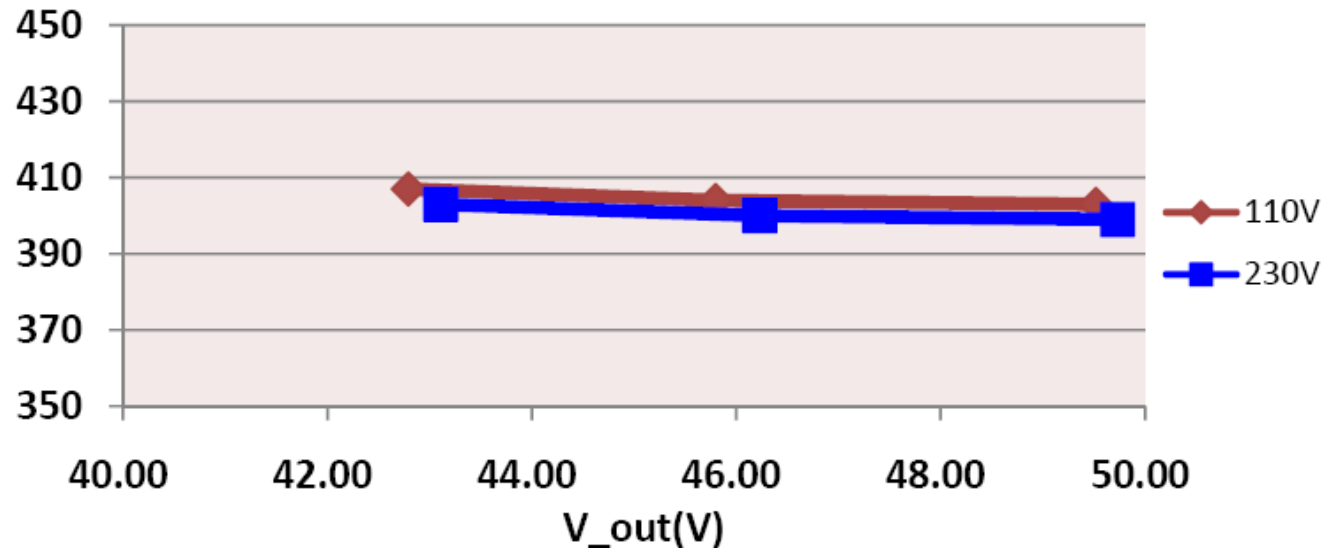

PCB layout

Top Trace

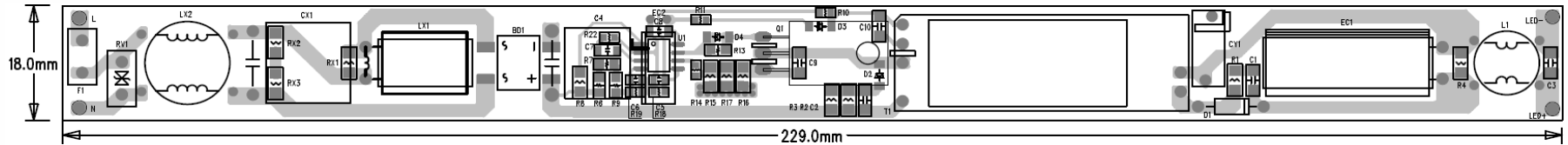

Bottom Trace

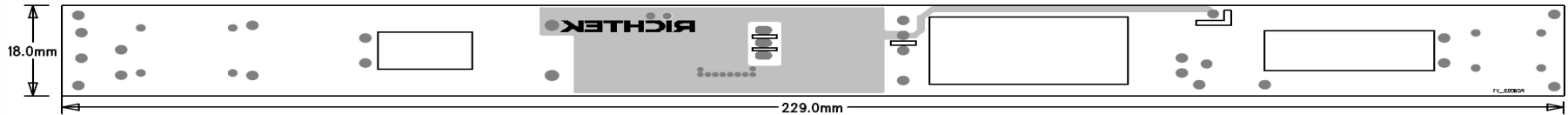

Demo board photo



Length	Width	Height
229mm	18mm	10mm

PCB No : PCB022_V1

BOM

Item	Location	Value	Type
1	F1	T1.25A/300V	SS-5F-2P
2	RV1	7N471K	TVS-2P
3	LX2	30mH	LRS-T14
4	CX1	0.1uF	CFS-12X12
5	LX1	5mH	LDS-D9X12
6	BD1	1A/600V	DB-1A
7	C4	0.1uF/500V	CFS-11X10
8	R6,R7,R9	2.2Mohm	0805
9	R19	43kohm	0603
10	C6	22nF/50V	0603
11	C7	2.2uF/25V	0805
12	R22	0ohm	0603

BOM

Item	Location	Value	Type
13	R8	10kohm	1206
14	R2	140kohm	1206
15	D2	FM4007	SOD123
16	C2	2.2nF/1kV	1206
17	R13	200R	0805
18	D4	1N4148	SOD-123
19	Q1	4A/600V	TO-220
20	C9	100p/1kV	1206
21	LX3	T3.5*3*1.4	---
22	R15,R16,R17	2.21ohm	1206
23	R14	2kohm	0603
24	C10	470p/1kV	1206

BOM

Item	Location	Value	Type
25	CY1	1000pF/250Vac	CAP-10mm
26	R10	60kohm	0603
27	R18	8.06kohm	0603
28	C5	22pF	0603
29	D3	BAV21	SOD-123
30	R11	82R	0603
31	EC2	33uF/50V	CES-5X11
32	T1	EDR28	EDR28
33	U1	RT7302	SOP-8
34	D1	SF26	DO-15
35	R1	33.2R	1206
36	C1	220p/1kV	1206

BOM

Item	Location	Value	Type
37	EC1	220uF/63V	CES-10X25
38	L1	110uF	LR-T9
39	R4	200kohm	1206
40	C8	47.5kohm	1206

Total : 44 pcs

Transformer

Transformer Specification

CORE SIZE: **EDR-28** Material: **PC40**
 Bobbin/PINs: **Horizontal / 7 pins**
 Primary inductor (+-5%) **920uH**
 Leakage inductor **30uH**
 Electrical :

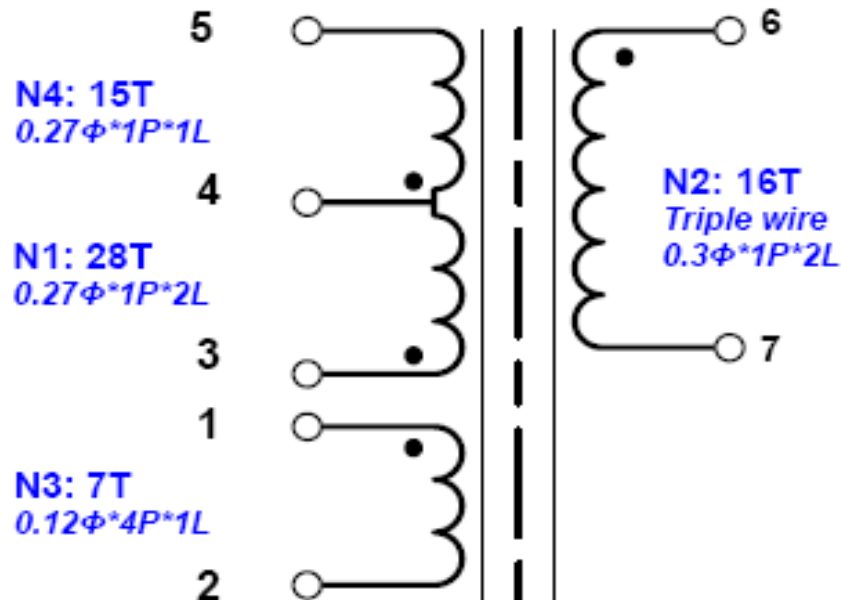

top view

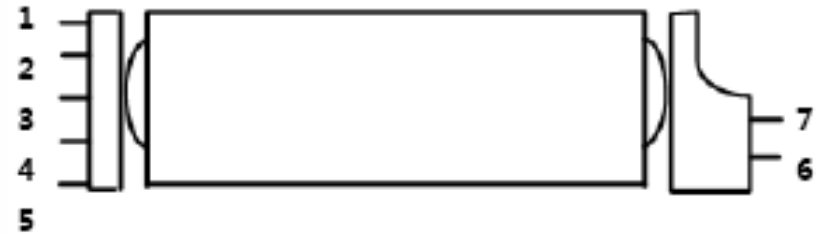

WINDING TABLE: (繞線結構)

Winding No. (組別)	PIN (腳位)	Wire & Wire & Copper (線徑 x 股數 x 層數)	Turns (圈數)	Winding Tape (繞線方式)	Tape Layer (膠帶層次)
<i>Bobbin</i>					
N1	3 → 4	0.27 x 1P x 2L	28Ts	密繞	2L
N2	6 → 7	Triple wire 0.3 x 1P x 2L	16Ts	密繞	2L
N3	1 → 2	0.12 x 4P x 1L	7Ts	密繞	1L
N4	4 → 5	0.27 x 1P x 1L	15Ts	密繞	1L
<i>Core - EDR28</i>				920uH	

Power Component Stress Voltage

Test condition: 90Vac input / 60V,300mA output

Stead state			
Location	Max rating (V)	Measure	De-rating
Q1	600	304	50.67%
D1	400	110	27.50%

Transient State			
Location	Max rating (V)	Measure	De-rating
Q1	600	304	50.67%
D1	400	110	27.50%

Power Component Stress Voltage

Test condition: 264Vac input / 60V,300mA output

Stead state			
Location	Max rating (V)	Measure	De-rating
Q1	600	568	94.67%
D1	400	227	56.75%

Transient State			
Location	Max rating (V)	Measure	De-rating
Q1	600	572	95.33%
D1	400	230	57.50%

Suggestion: If change the Q1 from 600V to 650V. The de-rating decrease to 87.38%(Stead state) and 88%(Transient state) .

Start up waveform

$V_{ac_in} = 90V$

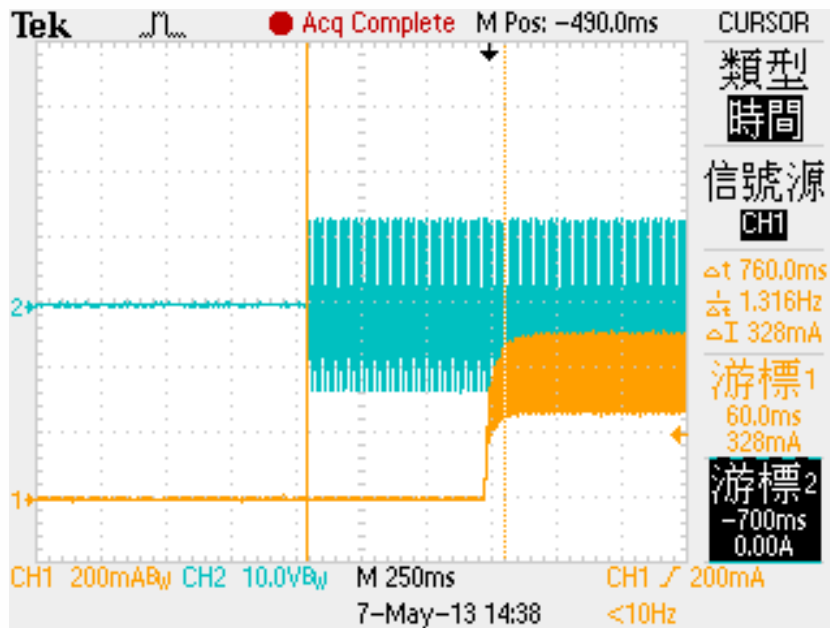

$T_{start\ up} = 760ms$

$V_{ac_in} = 264V$

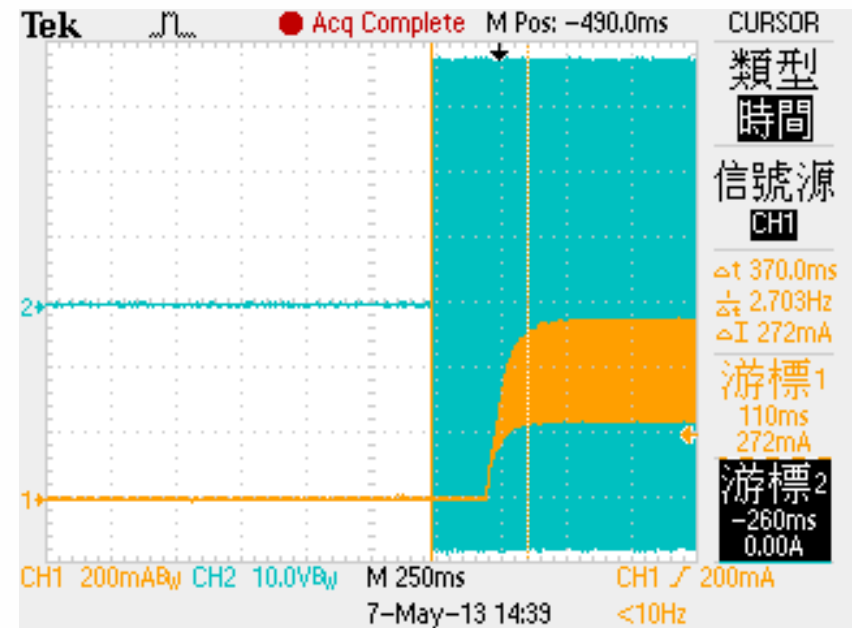

$T_{start\ up} = 370ms$

LED open protection

$V_{ac_in} = 90V$

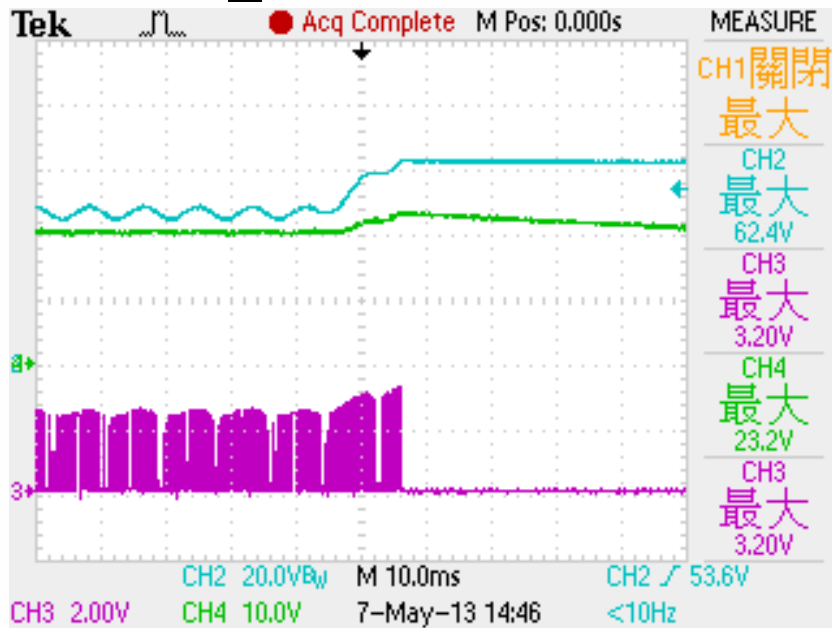

Ch2:Vout ; Ch3:Vzcd ; Ch4:Vdd

$V_{ac_in} = 264V$

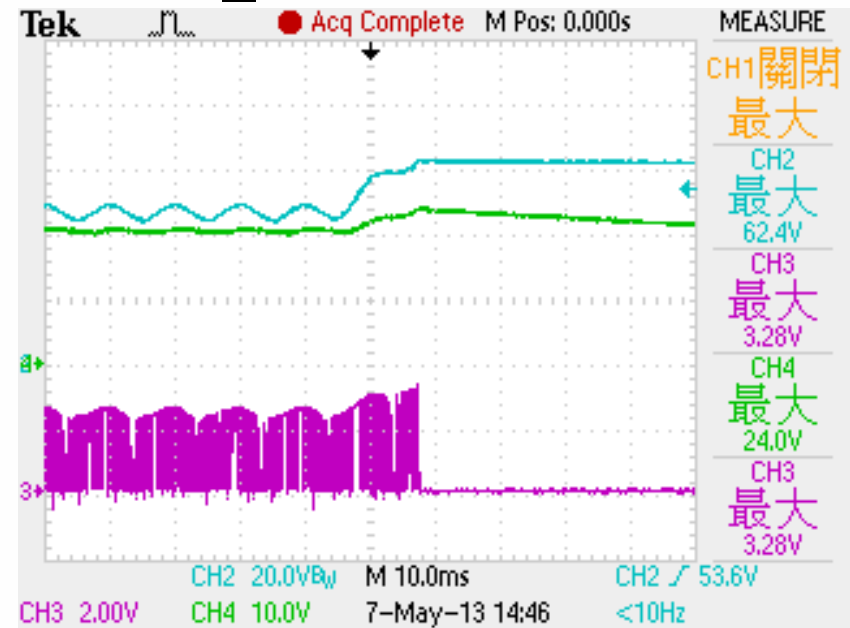

Ch2:Vout ; Ch3:Vzcd ; Ch4:Vdd

When LED open , the output keeps rising and causing the V_{ZCD} rising accordingly. If V_{zcd} trigger the protected level(2.9V~3.3V), the IC latch down. IC will be auto-restarted when the output is recovered.

LED Short protection

$V_{ac_in} = 90V$

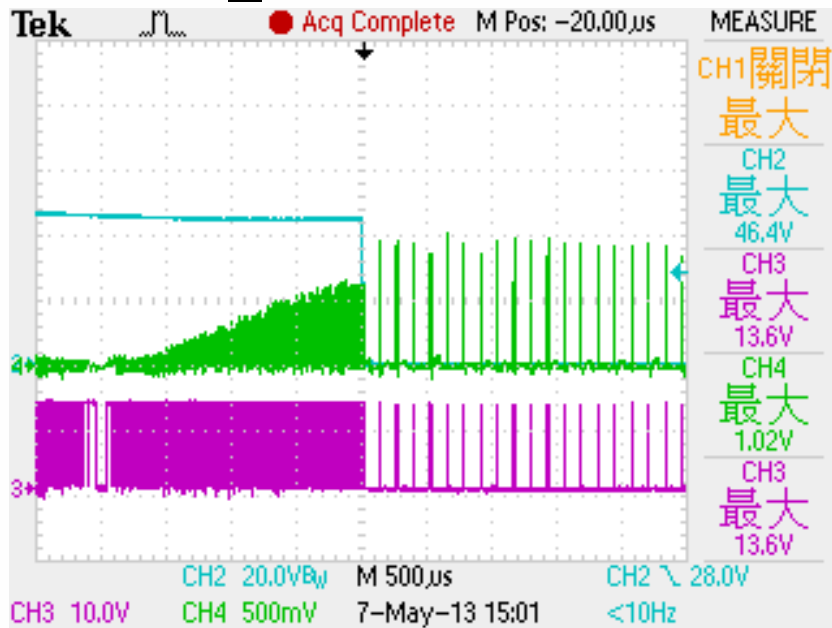

Ch2:Vout ; Ch3:Vgate ; Ch4:Vcs

$V_{ac_in} = 264V$

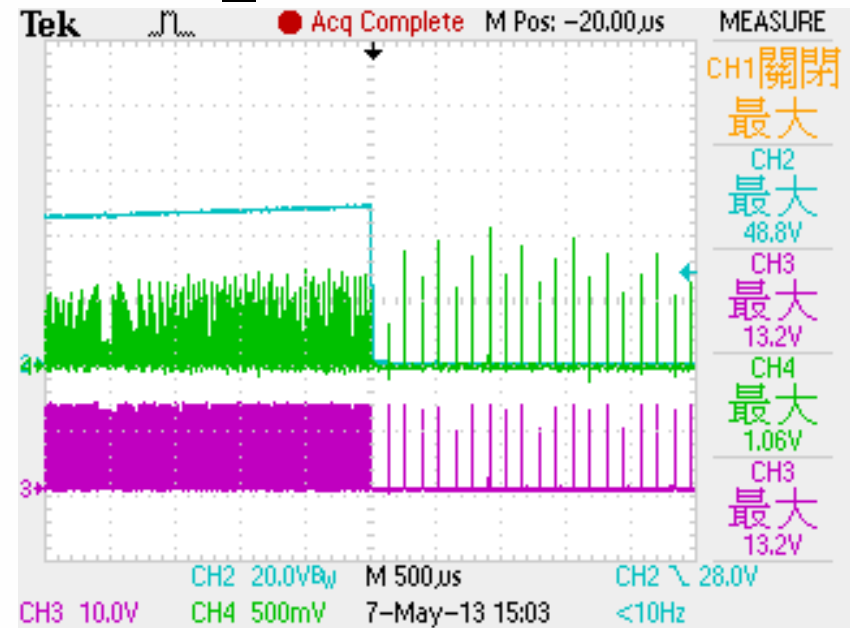

Ch2:Vout ; Ch3:Vgate ; Ch4:Vcs

When LED short , the output level is 0V and the Vcs will rise to trigger the protected function. IC will be auto-restarted when the output is recovered.

Harmonic(IEC61000-3-2)

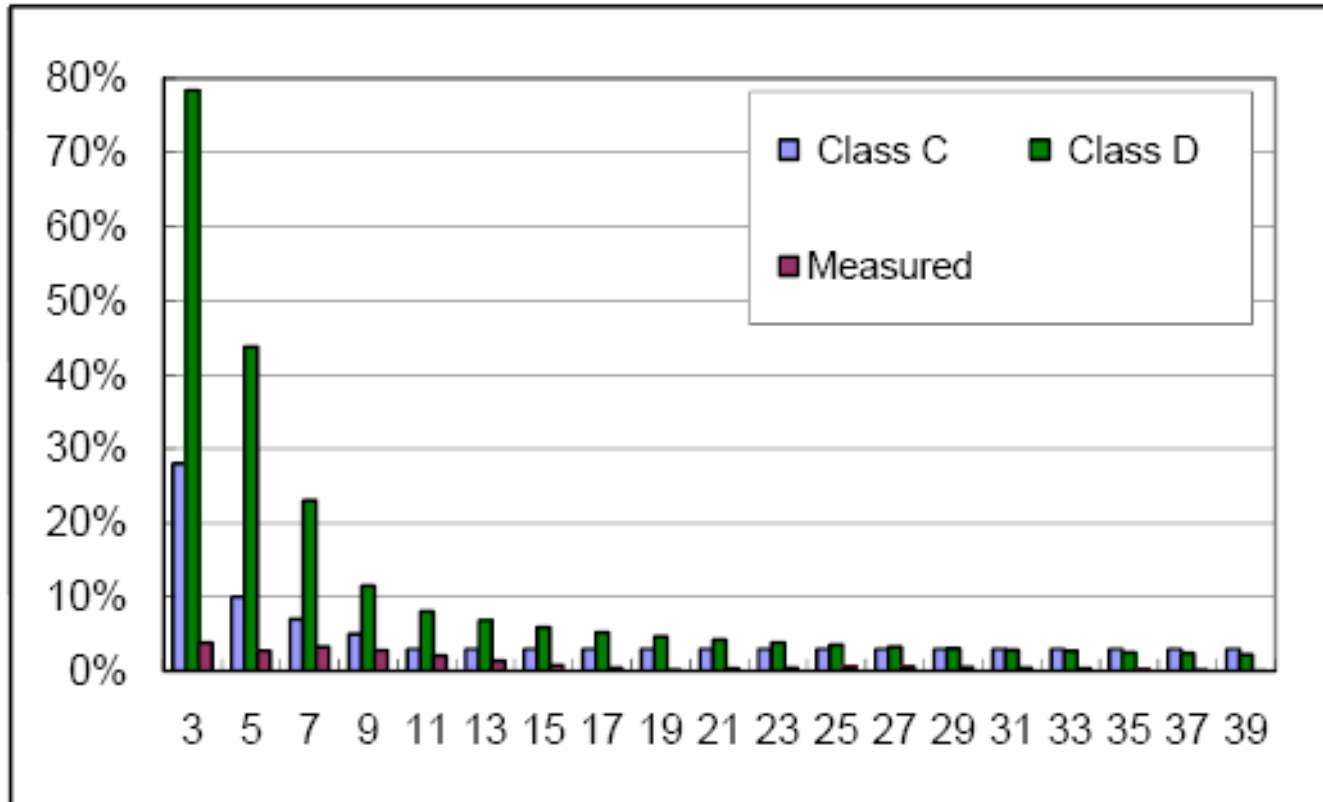

110V input
Class C : Pass
Class D : Pass

Harmonic(IEC61000-3-2)

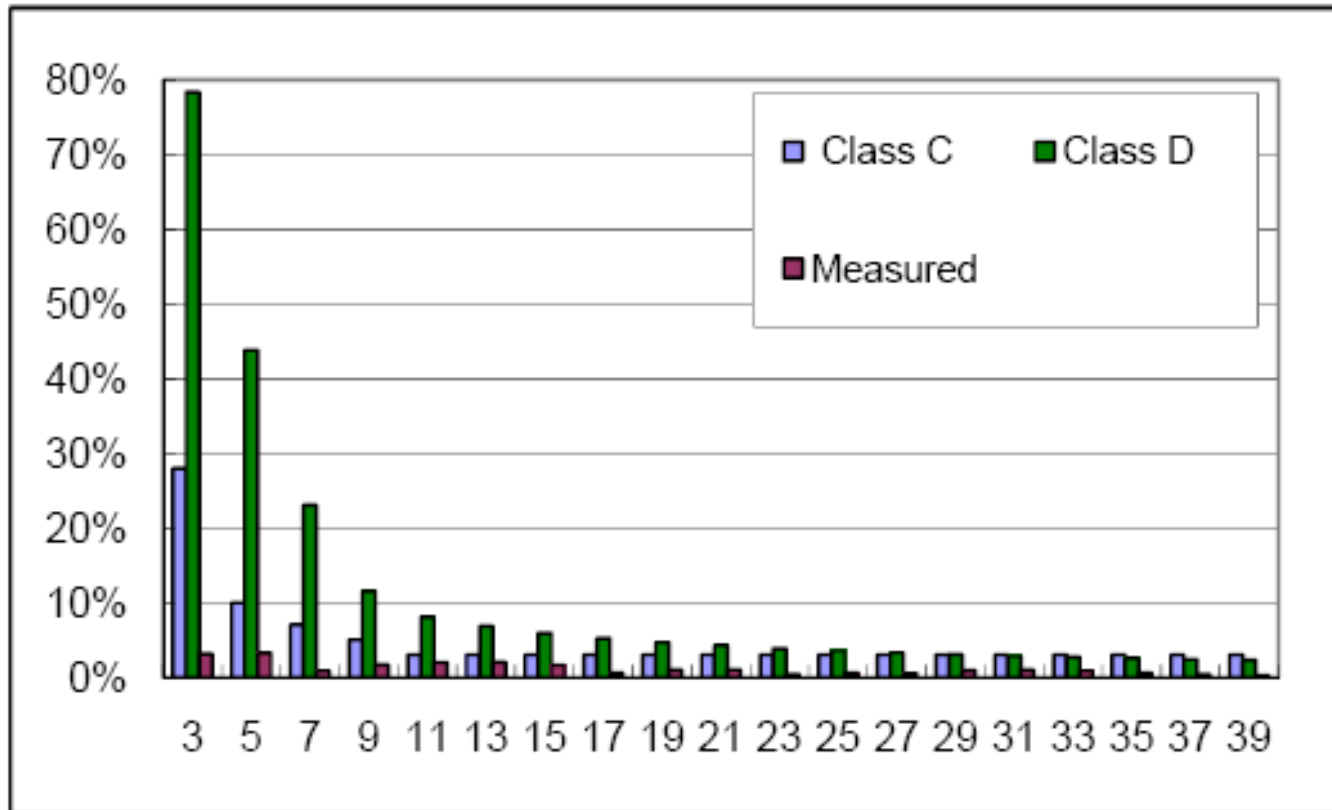

230V input
Class C : Pass
Class D : Pass

Conduction-EMI



230V-L → Pass

No.8 Lane 724, Bo Ai Street
Hsin Chu Hsien 302, Taiwan
TEL:03-656-9065
FAX:03-656-9085



230V-N → Pass

No.8 Lane 724, Bo Ai Street
Hsin Chu Hsien 302, Taiwan
TEL:03-656-9065
FAX:03-656-9085

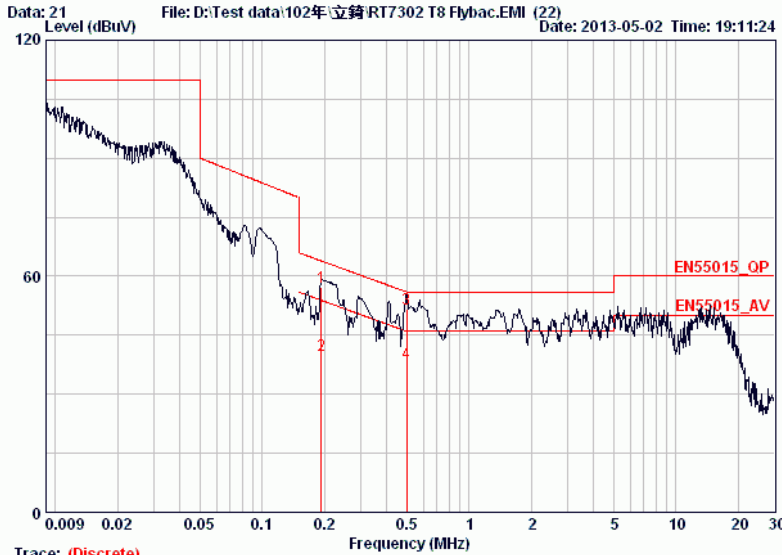

Trace: (Discrete)
Condition : EN55015_QP LISN 20120622 LINE
Engineer : Hank
Eut : RT7302 flyback 45V/400mA
Power : 230V
Mode :
Memo : LISN LINE
Memo-1 : original
Memo-2 :
Memo-3 :
Memo-4 :
Memo-5 :
Memo-6 :

	Freq	Level	Over Limit	Limit Line	Read Level	LISN Factor	Cable Loss	Pol/Phase	Remark
	MHz	dBuV	dB	dBuV	dBuV	dB	dB		
1 @	0.19315	57.16	-6.74	63.90	56.96	0.15	0.05	LINE	QP
2 @	0.19315	39.82	-14.08	53.90	39.62	0.15	0.05	LINE	AVERAGE
3 @	0.49896	51.77	-4.25	56.02	51.56	0.15	0.05	LINE	QP
4 @	0.49896	37.80	-8.22	46.02	37.59	0.15	0.05	LINE	AVERAGE

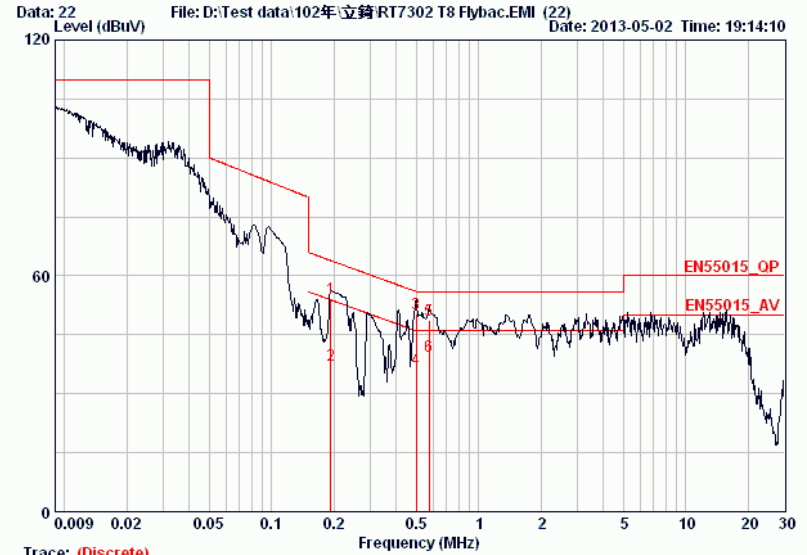

Trace: (Discrete)
Condition : EN55015_QP LISN 20120622 NEUTRAL
Engineer : Hank
Eut : RT7302 flyback 45V/400mA
Power : 230V
Mode :
Memo : LISN NEUTRAL
Memo-1 : original
Memo-2 :
Memo-3 :
Memo-4 :
Memo-5 :
Memo-6 :

	Freq	Level	Over Limit	Limit Line	Read Level	LISN Factor	Cable Loss	Pol/Phase	Remark
	MHz	dBuV	dB	dBuV	dBuV	dB	dB		
1 @	0.19315	54.36	-9.54	63.90	54.23	0.08	0.05	NEUTRAL	QP
2 @	0.19315	37.23	-16.67	53.90	37.10	0.08	0.05	NEUTRAL	AVERAGE
3 @	0.49896	50.21	-5.81	56.02	50.07	0.08	0.05	NEUTRAL	QP
4 @	0.49896	36.16	-9.86	46.02	36.02	0.08	0.05	NEUTRAL	AVERAGE
5 @	0.57740	48.57	-7.43	56.00	48.43	0.08	0.06	NEUTRAL	QP
6 @	0.57740	39.52	-6.48	46.00	39.38	0.08	0.06	NEUTRAL	AVERAGE

Conduction-EMI



110V-L → Pass

No.8 Lane 724, Bo Ai Street
Hsin Chu Hsien 302, Taiwan
TEL:03-656-9065
FAX:03-656-9085



110V-N → Pass

No.8 Lane 724, Bo Ai Str
Hsin Chu Hsien 302, Tai
TEL:03-656-9065
FAX:03-656-9085

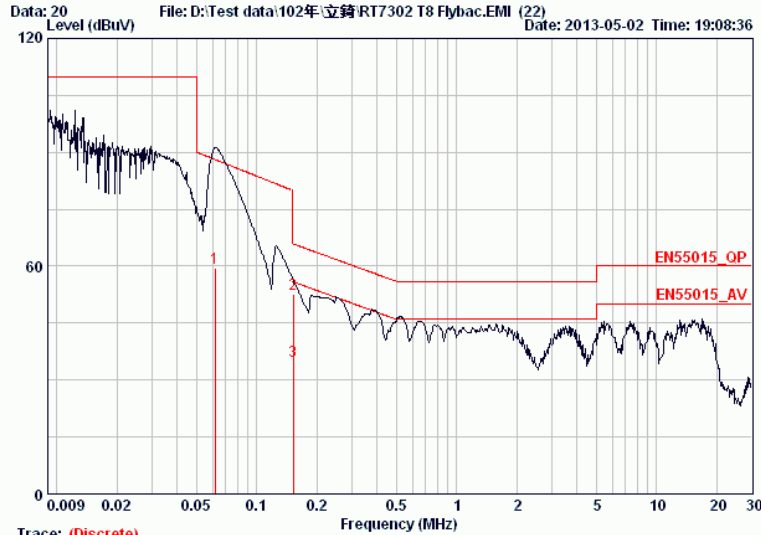

Trace: (Discrete)
Condition : EN55015_QP LISN 20120622 LINE
Engineer : Hank
Eut : RT7302 flyback 45V/400mA
Power : 110V
Mode :
Memo : LISN LINE
Memo-1 : original
Memo-2 :
Memo-3 :
Memo-4 :
Memo-5 :
Memo-6 :

	Freq	Level	Over Limit	Limit Line	Read Level	LISN Factor	Cable Loss	Pol/Phase	Remark
	MHz	dBuV	dB	dBuV	dBuV	dB	dB		
1	0.06204	59.66	-28.37	88.04	59.34	0.22	0.10	LINE	QP
2 @	0.15266	52.50	-13.35	65.85	52.28	0.16	0.06	LINE	QP
3	0.15266	34.96	-20.89	55.85	34.74	0.16	0.06	LINE	AVERAGE

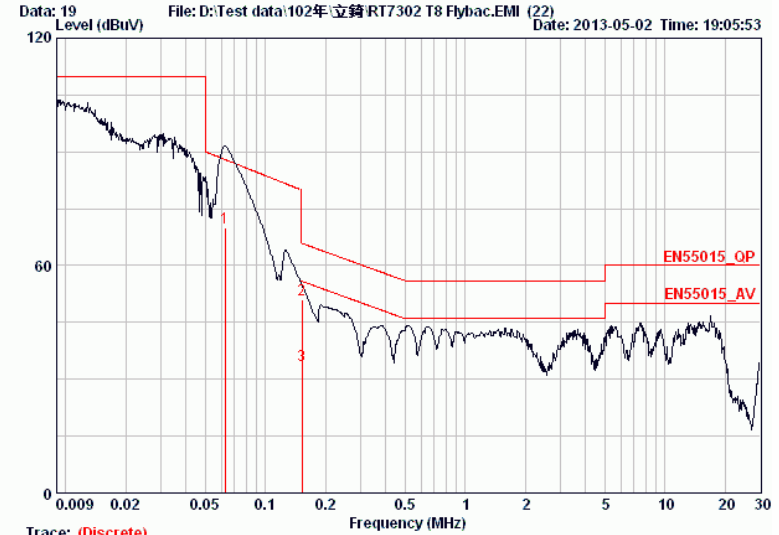

Trace: (Discrete)
Condition : EN55015_QP LISN 20120622 NEUTRAL
Engineer : Hank
Eut : RT7302 flyback 45V/400mA
Power : 110V
Mode :
Memo : LISN NEUTRAL
Memo-1 : original
Memo-2 :
Memo-3 :
Memo-4 :
Memo-5 :
Memo-6 :

	Freq	Level	Over Limit	Limit Line	Read Level	LISN Factor	Cable Loss	Pol/Phase	Remark
	MHz	dBuV	dB	dBuV	dBuV	dB	dB		
1	0.06255	70.09	-17.87	87.96	69.86	0.13	0.10	NEUTRAL	QP
2 @	0.15266	51.05	-14.80	65.85	50.91	0.08	0.06	NEUTRAL	QP
3	0.15266	33.60	-22.25	55.85	33.46	0.08	0.06	NEUTRAL	AVERAGE

Radiation-EMI



230V-V → Pass

Data: 4 File: D:\客户test data\立錡\RT7302.EM6 (7) Date: 2013-05-03 Time: 11:29:41

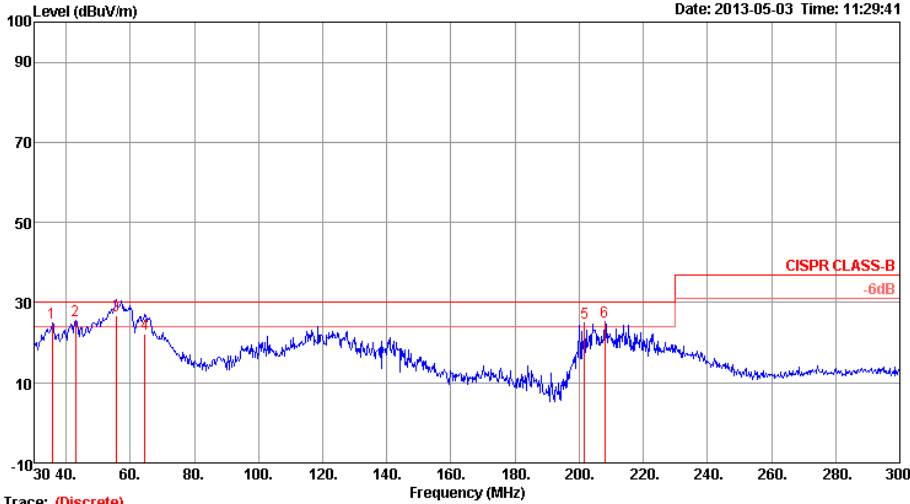

Trace: (Discrete)
 Site : 03CH03-CB
 Condition : CISPR CLASS-B 10m BILOG ANT 6112D VERTICAL
 Engineer : Robert
 Eut : RT7302
 Mode :
 Power : 230V/50Hz
 Temp : 24.5°C
 Humidity : 57%
 Atmosphere: 98.6Kpa
 Memo : Rg=200ohm / source add bead / D-S 100p
 : diode sunber 33.2ohm / 1N4007

Peak	Freq	Level	Limit	Over	Read	Cable	Antenna	Preamp	Remark	A/Pos	T/Pos	Pol/Phase
	MHz	dBuV/m	dBuV/m	dB	dBuV	dB	dB/m	dB		cm	deg	
1	35.67	24.94	30.00	-5.06	44.59	0.69	15.49	27.80	Peak	156	360	VERTICAL
2	42.96	25.41	30.00	-4.59	49.55	0.70	11.44	27.80	Peak	100	360	VERTICAL
3	55.65	26.91	30.00	-3.09	50.70	0.84	7.65	27.78	QP	100	152	VERTICAL
4	64.56	22.17	30.00	-7.83	46.30	0.94	6.70	27.74	QP	100	340	VERTICAL
5	201.72	24.95	30.00	-5.05	43.19	1.66	9.19	27.09	Peak	156	360	VERTICAL
6	207.93	25.33	30.00	-4.67	42.69	1.68	9.62	27.08	Peak	156	360	VERTICAL



230V-H → Pass

Data: 5 File: D:\客户test data\立錡\RT7302.EM6 (7) Date: 2013-05-03 Time: 11:38:25

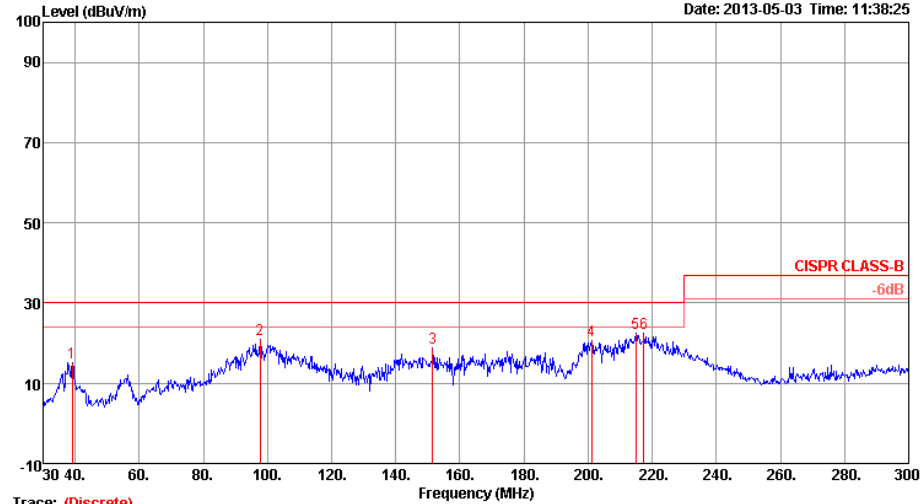

Trace: (Discrete)
 Site : 03CH03-CB
 Condition : CISPR CLASS-B 10m BILOG ANT 6112D HORIZONTAL
 Engineer : Robert
 Eut : RT7302
 Mode :
 Power : 230V/50Hz
 Temp : 24.5°C
 Humidity : 57%
 Atmosphere: 98.6Kpa
 Memo : Rg=200ohm / source add bead / D-S 100p
 : diode sunber 33.2ohm / 1N4007

Peak	Freq	Level	Limit	Over	Read	Cable	Antenna	Preamp	Remark	A/Pos	T/Pos	Pol/Phase
	MHz	dBuV/m	dBuV/m	dB	dBuV	dB	dB/m	dB		cm	deg	
1	39.18	15.24	30.00	-14.76	38.67	0.67	13.70	27.80	Peak	40	0	HORIZONTAL
2	97.77	20.97	30.00	-9.03	47.81	1.18	10.59	27.61	Peak	40	0	HORIZONTAL
3	151.50	18.86	30.00	-11.14	44.42	1.41	11.87	27.34	Peak	40	0	HORIZONTAL
4	201.18	20.56	30.00	-9.44	44.88	1.66	9.12	27.10	Peak	40	0	HORIZONTAL
5	214.95	22.48	30.00	-7.52	44.16	1.70	10.19	27.07	Peak	40	0	HORIZONTAL
6	217.38	22.45	30.00	-7.55	43.97	1.70	10.34	27.06	Peak	40	0	HORIZONTAL

Radiation-EMI



110V-V → Pass

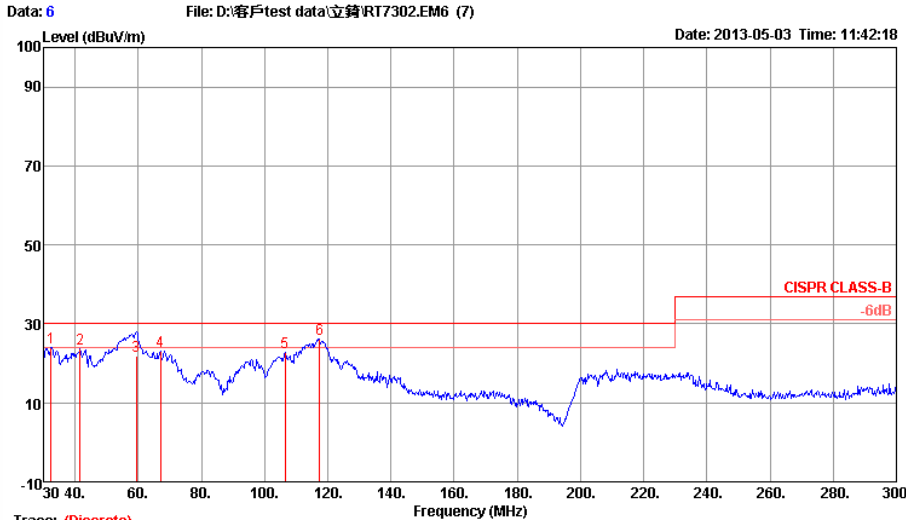

Trace: (Discrete)
 Site : 03CH03-CB
 Condition : CISPR CLASS-B 10m BILOG ANT 6112D VERTICAL
 Engineer : Robert
 Eut : RT7302
 Mode :
 Power : 110V/60Hz
 Temp : 24.5°C
 Humidity : 57%
 Atmosphere : 98.6Kpa
 Memo : Rg=200ohm / source add bead / D-S 100p
 : diode sunber 33.2ohm / 1N4007

	Freq	Level	Limit	Over	Read	CableAntenna	Preamp	Remark	A/Pos	T/Pos	Pol/Phase
	MHz	dBuV/m	dB	dB	dBuV	dB	dB/m	dB	cm	deg	
1	32.43	23.99	30.00	-6.01	41.10	0.66	17.15	27.80	154	360	VERTICAL
2	41.61	23.55	30.00	-6.45	47.36	0.69	11.99	27.80	154	360	VERTICAL
3	59.43	21.85	30.00	-8.15	46.59	0.90	6.95	27.76	100	360	VERTICAL
4	66.99	23.00	30.00	-7.00	47.42	0.96	6.68	27.73	154	360	VERTICAL
5	106.41	22.70	30.00	-7.30	43.79	1.21	11.50	27.57	154	360	VERTICAL
6	117.48	26.16	30.00	-3.84	44.24	1.28	12.31	27.51	154	360	VERTICAL



110V-H → Pass

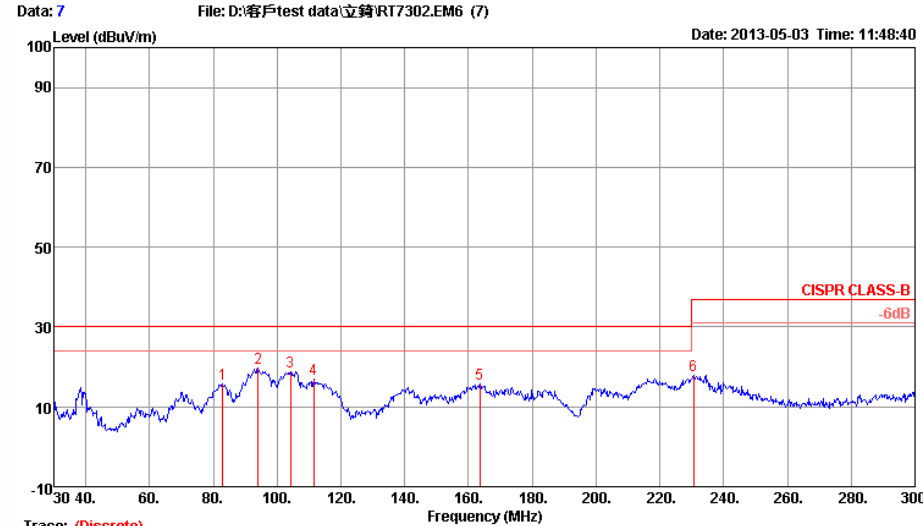

Trace: (Discrete)
 Site : 03CH03-CB
 Condition : CISPR CLASS-B 10m BILOG ANT 6112D HORIZONTAL
 Engineer : Robert
 Eut : RT7302
 Mode :
 Power : 110V/60Hz
 Temp : 24.5°C
 Humidity : 57%
 Atmosphere : 98.6Kpa
 Memo : Rg=200ohm / source add bead / D-S 100p
 : diode sunber 33.2ohm / 1N4007

	Freq	Level	Limit	Over	Read	CableAntenna	Preamp	Remark	A/Pos	T/Pos	Pol/Phase
	MHz	dBuV/m	dB	dB	dBuV	dB	dB/m	dB	cm	deg	
1	82.92	15.64	30.00	-14.36	45.53	1.07	7.71	27.67	200	360	HORIZONTAL
2	93.99	19.64	30.00	-10.36	47.33	1.16	9.78	27.63	200	360	HORIZONTAL
3	104.25	18.80	30.00	-11.20	44.82	1.20	11.36	27.58	200	360	HORIZONTAL
4	111.54	16.81	30.00	-13.19	42.57	1.24	11.87	27.54	200	360	HORIZONTAL
5	163.65	15.63	30.00	-14.37	39.86	1.43	12.32	27.28	200	360	HORIZONTAL
6	230.61	18.00	37.00	-19.00	38.07	1.73	11.34	27.04	200	360	HORIZONTAL

RICHTEK
your power partner.

thank you.

Looking for pricing, stock, or lifecycle information?

Click below to explore more details on WIN SOURCE:

 [View EVB_RT7302GS on WIN SOURCE](#)

 [Richtek USA Inc. Information](#)

Optimize Your Supply Chain with WIN SOURCE Solutions

-  Global Sourcing Solution
-  Obsolete Management
-  Cost Control Management
-  Shortage Management
-  Alternative Solution
-  Excess Inventory Management