



**THE DATASHEET OF
EVB_RT7296AGJ8F**



RT7296AGJ8F Step-Down Converter Evaluation Board

Purpose

The RT7296A is a current mode step-down converter with the input voltage range from 4.5V to 17V and provides 3A output current. This document explains the function and use of the RT7296A evaluation board (EVB), and provides information to enable operation, modification of the evaluation board and circuit to suit individual requirements.

Table of Contents

Purpose	1
Introduction.....	2
Key Performance Summary Table	2
Bench Test Setup Conditions	3
Schematic, Bill of Materials & Board Layout	5
More Information.....	8
Important Notice for Richtek Evaluation Board	8

Introduction

General Product Information

The RT7296A is a high-efficiency, 3A current mode synchronous step-down DC/DC converter with a wide input voltage range from 4.5V to 17V. The device integrates 80mΩ high-side and 30mΩ low-side MOSFETs to achieve high efficiency conversion. The current mode control architecture supports fast transient response and internal compensation. A cycle-by-cycle current limit function provides protection against shorted output. The RT7296A provides complete protection functions such as input under-voltage lockout, output under-voltage protection, over-current protection, and thermal shutdown. The PWM frequency is adjustable by the EN/SYNC pin. The RT7296A is available in the TSOT-23-8 (FC) package.

Product Feature

- 4.5V to 17V Input Voltage Range
- 3A Output Current
- Internal N-Channel MOSFETs
- Current Mode Control
- Fixed Switching Frequency : 500kHz
- Synchronous to External Clock : 200kHz to 2MHz
- Cycle-by-Cycle Current Limit
- TTH Power-Save Mode
- Internal Soft-Start Function
- Input Under-Voltage Lockout
- Output Under-Voltage Protection
- Thermal Shutdown

Key Performance Summary Table

Key Features		Evaluation Board Number : PCB040_V1	
Default Input Voltage	12V		
Max Output Current	3A		
Default Output Voltage	3.3V		
Default Marking & Package Type	RT7296AGJ8F, TSOT-23-8 (FC)		
Operation Frequency	Steady 500kHz at all loads		

Bench Test Setup Conditions

Headers Description and Placement

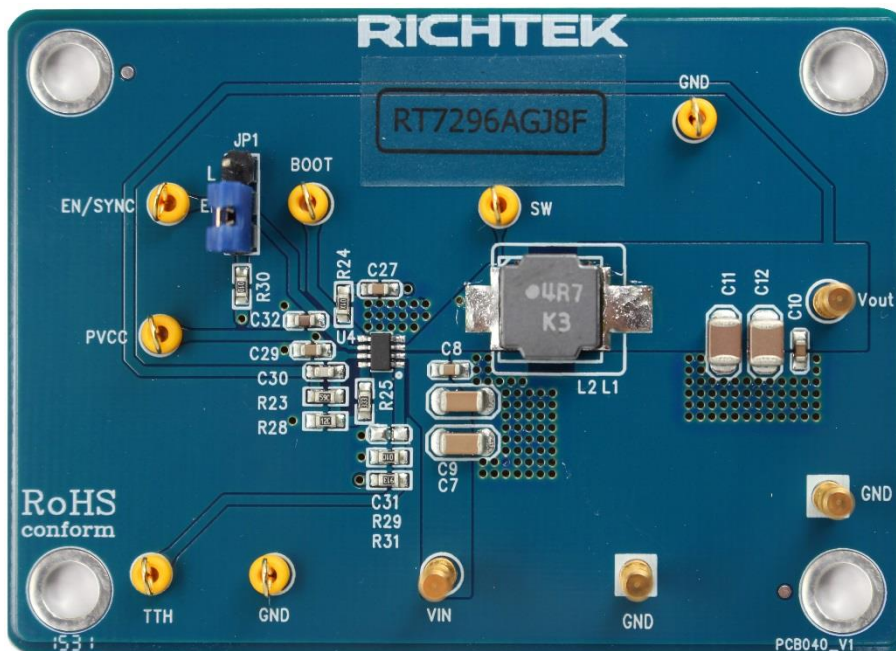

Please carefully inspect the EVB IC and external components, comparing them to the following Bill of Materials, to ensure that all components are installed and undamaged. If any components are missing or damaged during transportation, please contact the distributor or send e-mail to evb_service@richtek.com

Test Points

The EVB is provided with the test points and pin names listed in the table below.

Test point/ Pin name	Signal	Comment (expected waveforms or voltage levels on test points)
VIN	Input voltage	Power input. Support 4.5V to 17V Input Voltage. Must bypass with a suitable large ceramic capacitor at this pin.
EN/SYNC	Enable test point	High = Enable. Apply an external clock to adjust the switching frequency.
GND	Ground	Ground.
TTH	Transition threshold	Connect a resistor divider to let the RT7296A into power saving mode under light loads. Connect to PVCC to force RT7296A into forced PWM mode.
PVCC	Internal regulator output	5V bias supply output. Connect a 0.1 μ F capacitor to ground.
BOOT	Bootstrap supply test point	Bootstrap supply for high-side gate driver. Connect a 0.1 μ F ceramic capacitor between the BOOT and SW pins.
SW	Switch node test point	Connect this pin to an external L-C filter.

Power-up & Measurement Procedure

1. Apply a 12V nominal input power supply ($4.5V < V_{IN} < 17V$) to the VIN and GND terminals.
2. Set the jumper at JP1 to connect terminals 2 and 3, connecting EN to VIN through resistor R30, to enable operation.
3. Verify the output voltage (approximately 3.3V) between VOUT and GND.
4. Connect an external load up to 3A to the VOUT and GND terminals and verify the output voltage and current.

Output Voltage Setting

Set the output voltage with the resistive divider (R23, R28) between VOUT and GND with the midpoint connected to FB. The output is set by the following formula :

$$V_{OUT} = 0.8 \times \left(1 + \frac{R_{23}}{R_{28}} \right)$$

Schematic, Bill of Materials & Board Layout

EVB Schematic Diagram

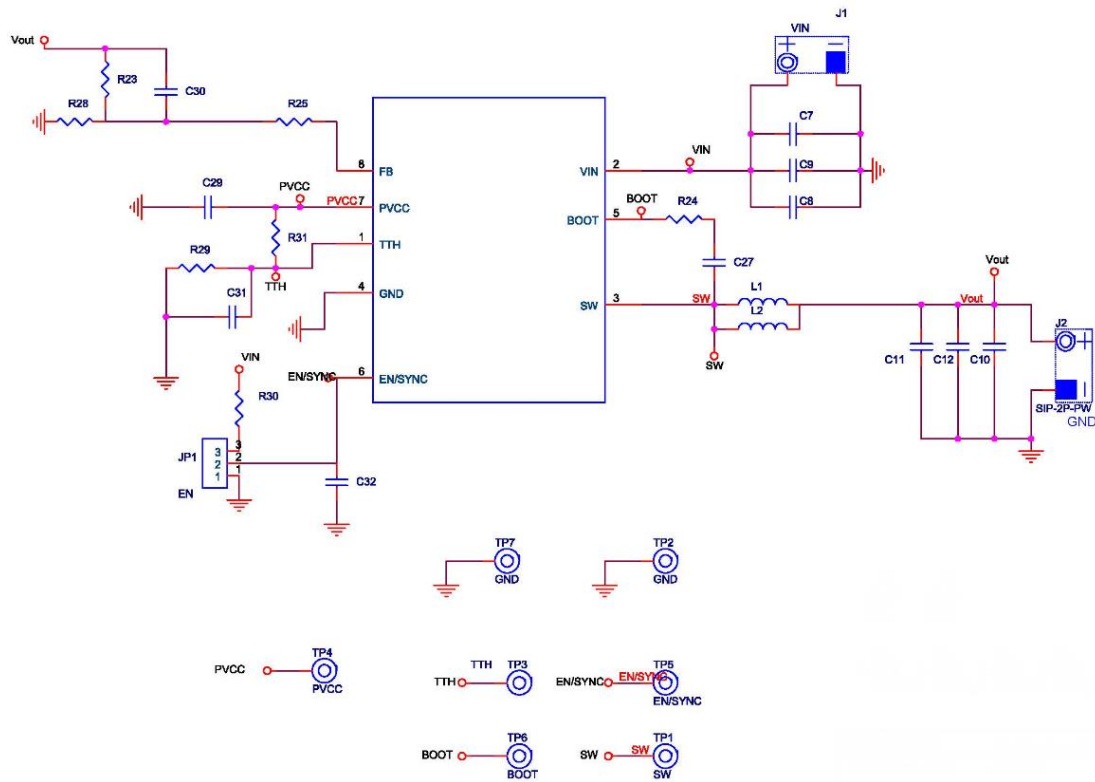

Bill of Materials

Reference	Qty	Part Number	Description	Package	Manufacture
U4	1	RT7296AGJ8F	DC/DC Converter	TSOT-23-8 (FC)	RICHTEK
C7, C9	2	GRM31CR71E106KA12L	10 μ F/25V/X7R	C-1206	MURATA
C8, C10, C27, C29	4	C1608X7R1H104K080AA	0.1 μ F/ \pm 10%/50V/X7R	C-0603	TDK
C11, C12	2	C3225X5R1E226MT	22 μ F/25V/X7R	C-1210	TDK
C30	1	0603N220J500	22pF/50V/NPO	C-0603	WALSIN
C31	1		NC		
C32	1	C1608X5R1E105KT000E	1 μ F/ \pm 10%/25V/X5R	C-0603	TDK
L1	1	NR8040T4R7N	4.7 μ H/4.1A	8 x 8 x 4.2 mm	TAIYO YUDEN
R23	1		40.2k	R-0603	
R24	1		10	R-0603	
R25	1		33k	R-0603	
R28	1		13k	R-0603	
R29	1		10k	R-0603	
R30	1		100k	R-0603	
R31	1		91k	R-0603	

PCB Layout

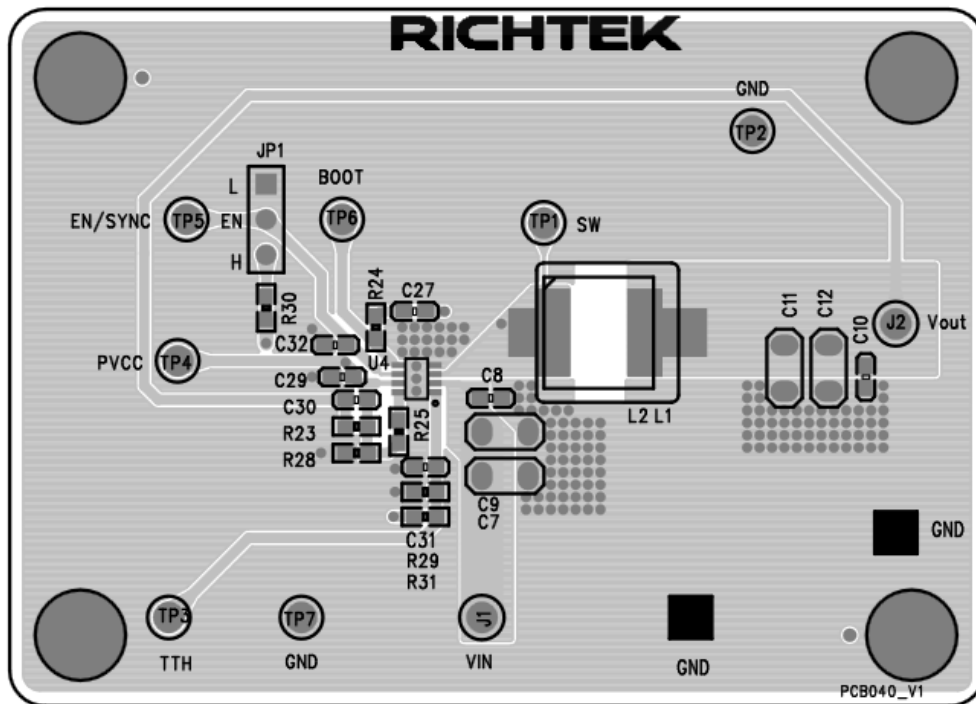

Top View (1st layer)

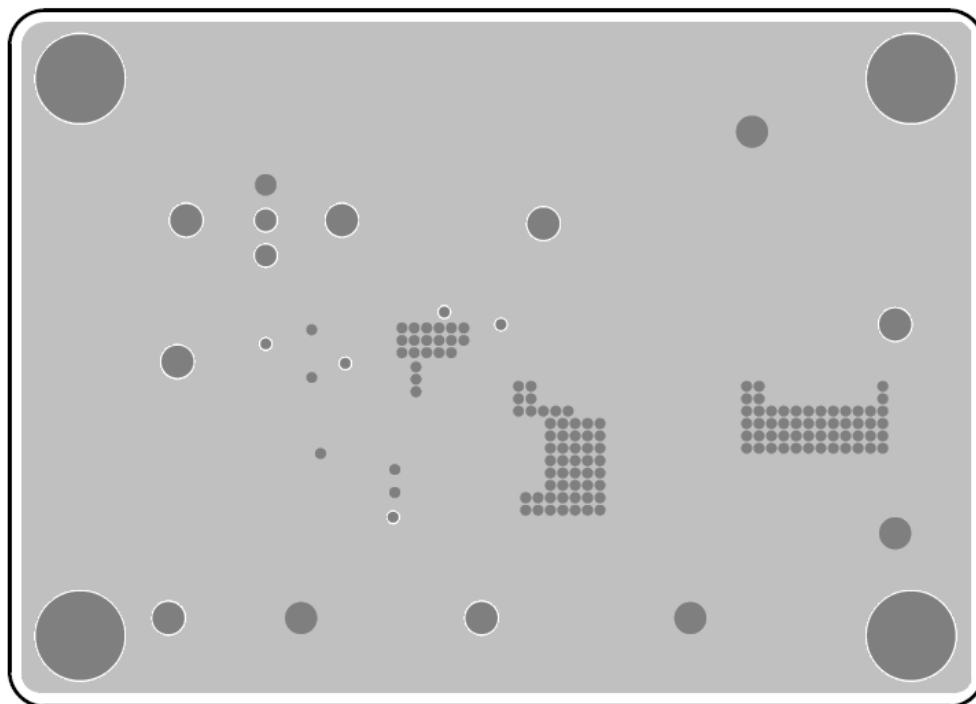

PCB Layout—Inner Side (2nd Layer)

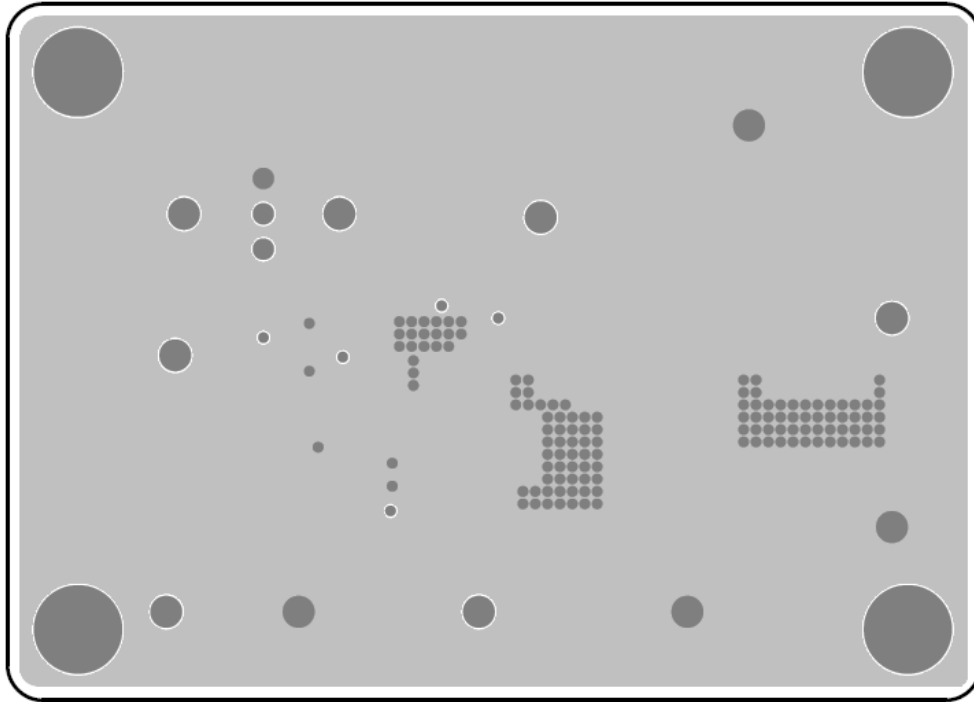

PCB Layout—Inner Side (3rd Layer)

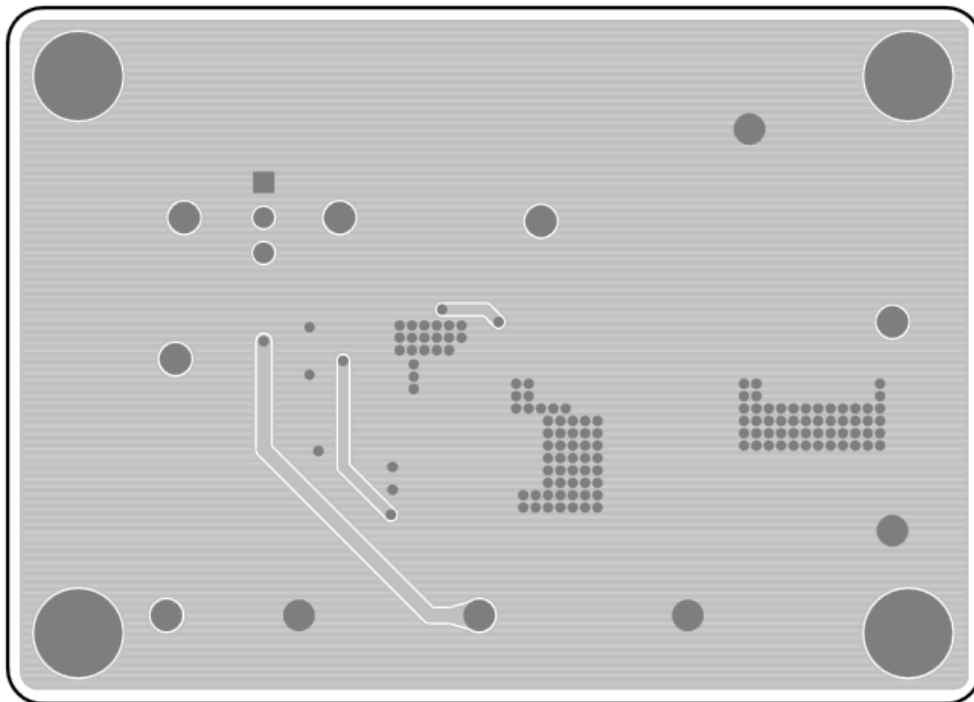

Bottom View (4th Layer)

More Information



For more information, please find the related datasheet or application notes from Richtek website <http://www.richtek.com>.

Important Notice for Richtek Evaluation Board







THIS DOCUMENT IS FOR REFERENCE ONLY, NOTHING CONTAINED IN THIS DOCUMENT SHALL BE CONSTRUED AS RICHTEK'S WARRANTY, EXPRESS OR IMPLIED, UNDER CONTRACT, TORT OR STATUTORY, WITH RESPECT TO THE PRESENTATION HEREIN. IN NO EVENT SHALL RICHTEK BE LIABLE TO BUYER OR USER FOR ANY AND ALL DAMAGES INCLUDING WITHOUT LIMITATION TO DIRECT, INDIRECT, SPECIAL, PUNITIVE OR CONSEQUENTIAL DAMAGES.

Looking for pricing, stock, or lifecycle information?

Click below to explore more details on WIN SOURCE:

-  [View EVB_RT7296AGJ8F on WIN SOURCE](#)
-  [Richtek USA Inc. Information](#)

Optimize Your Supply Chain with WIN SOURCE Solutions

-  Global Sourcing Solution
-  Obsolete Management
-  Cost Control Management
-  Shortage Management
-  Alternative Solution
-  Excess Inventory Management