



**THE DATASHEET OF
RF2046TR7**



RoHS Compliant & Pb-Free Product
Package Style: Micro-X Ceramic

Features

- DC to 3000MHz Operation
- Internally matched Input and Output
- 22dB Small Signal Gain
- 3.0dB Noise Figure
- 10mW Linear Output Power
- Single Positive Power Supply

Applications

- Broadband, Low Noise Gain Blocks
- IF or RF Buffer Amplifiers
- Driver Stage for Power Amplifiers
- Final PA for Low Power Applications
- High Reliability Applications
- Broadband Test Equipment

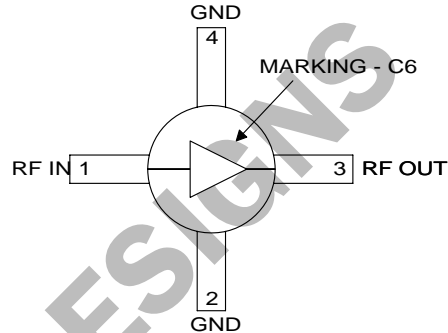

Functional Block Diagram

Product Description

The RF2046 is a general purpose, low cost RF amplifier IC. The device is manufactured on an advanced Gallium Arsenide Heterojunction Bipolar Transistor (HBT) process, and has been designed for use as an easily-cascadable 50Ω gain block. Applications include IF and RF amplification in wireless voice and data communication products operating in frequency bands up to 3000MHz. The device is self-contained with 50Ω input and output impedances and requires only two external DC biasing elements to operate as specified. With a goal of enhanced reliability, the extremely small Micro-X ceramic package offers significantly lower thermal resistance than similar size plastic packages.

Ordering Information

RF2046	General Purpose Amplifier
RF2046PCBA-41X	Fully Assembled Evaluation Board

Optimum Technology Matching® Applied

- | | | | |
|--|--------------------------------------|-------------------------------------|-----------------------------------|
| <input checked="" type="checkbox"/> GaAs HBT | <input type="checkbox"/> SiGe BiCMOS | <input type="checkbox"/> GaAs pHEMT | <input type="checkbox"/> GaN HEMT |
| <input type="checkbox"/> GaAs MESFET | <input type="checkbox"/> Si BiCMOS | <input type="checkbox"/> Si CMOS | |
| <input type="checkbox"/> InGaP HBT | <input type="checkbox"/> SiGe HBT | <input type="checkbox"/> Si BJT | |

RF MICRO DEVICES®, RFMD®, Optimum Technology Matching®, Enabling Wireless Connectivity™, PowerStar®, POLARIS™ TOTAL RADIO™ and UltimateBlue™ are trademarks of RFMD, LLC. BLUETOOTH is a trademark owned by Bluetooth SIG, Inc., U.S.A. and licensed for use by RFMD. All other trade names, trademarks and registered trademarks are the property of their respective owners. ©2006, RF Micro Devices, Inc.

Absolute Maximum Ratings

Parameter	Rating	Unit
Input RF Power	+13	dBm
Operating Ambient Temperature	-40 to +85	°C
Storage Temperature	-60 to +150	°C



Caution! ESD sensitive device.

The information in this publication is believed to be accurate and reliable. However, no responsibility is assumed by RF Micro Devices, Inc. ("RFMD") for its use, nor for any infringement of patents, or other rights of third parties, resulting from its use. No license is granted by implication or otherwise under any patent or patent rights of RFMD. RFMD reserves the right to change component circuitry, recommended application circuitry and specifications at any time without prior notice.

RoHS status based on EUDirective2002/95/EC (at time of this document revision).

Parameter	Specification			Unit	Condition
	Min.	Typ.	Max.		
Overall					T=25 °C, V _D =3.5V, I _{CC} =35mA
Frequency Range		DC to 3000		MHz	
Gain		22.7		dB	Freq = 100MHz
		22.1		dB	Freq = 1000MHz
	18	21.0		dB	Freq = 2000MHz
		19.2		dB	Freq = 3000MHz
Gain Flatness		±0.9		dB	100MHz to 2000MHz
Noise Figure		2.7		dB	Freq = 2000MHz
Input VSWR		<2.0:1			In a 50Ω system, DC to 3000MHz
Output VSWR		<1.9:1			In a 50Ω system, DC to 3000MHz
Output IP ₃		+23.5		dBm	Freq = 2000MHz ± 100kHz, P _{TONE} = -18dBm
Output P _{1dB}		+10.7		dBm	Freq = 2000MHz
Reverse Isolation		22.8		dB	Freq = 2000MHz
Thermal					I _{CC} = 35mA, P _{DISS} = 116mW (See Note 1.)
Theta _{JC}		275		°C/W	
Maximum Measured Junction Temperature at DC Bias Conditions		117		°C	
Mean Time To Failure (MTTF)		280,000		years	T _{AMB} = +85 °C
Power Supply					With 22Ω bias resistor, T = +25 °C
Device Operating Voltage	3.0	3.5	4.0	V	At pin 3 with I _{CC} = 35mA
	3.6	4.3	4.6	V	At evaluation board connector, I _{CC} = 35mA
Operating Current			35	mA	See Note 2.

NOTES:

Note 1: The RF2046 must be operated at or below 35mA in order to achieve the thermal performance stated above. Operating at 35mA will ensure the best possible combination of reliability and electrical performance.

Note 2: Because of process variations from part to part, the current resulting from a fixed bias voltage will vary. As a result, caution should be used in designing fixed voltage bias circuits to ensure the worst case bias current does not exceed 35mA over all intended operating conditions.

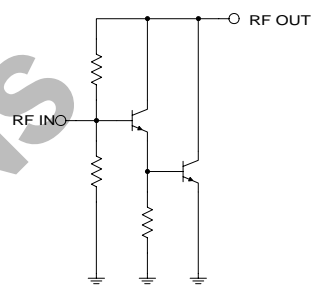
Pin	Function	Description	Interface Schematic
1	RF IN	RF input pin. This pin is NOT internally DC-blocked. A DC-blocking capacitor, suitable for the frequency of operation, should be used in most applications. DC-coupling of the input is not allowed, because this will override the internal feedback loop and cause temperature instability.	
2	GND	Ground connection. For best performance, keep traces physically short and connect immediately to ground plane.	
3	RF OUT	RF output and bias pin. Biasing is accomplished with an external series resistor and choke inductor to V _{CC} . The resistor is selected to set the DC current into this pin to a desired level. The resistor value is determined by the following equation: $R = \frac{(V_{SUPPLY} - V_{DEVICE})}{I_{CC}}$ <p>Care should also be taken in the resistor selection to ensure that the current into the part never exceeds 35mA over the planned operating temperature. This means that a resistor between the supply and this pin is always required, even if a supply near 3.5V is available, to provide DC feedback to prevent thermal runaway. Because DC is present on this pin, a DC-blocking capacitor, suitable for the frequency of operation, should be used in most applications. The supply side of the bias network should also be well bypassed.</p>	
4	GND	Same as pin 2.	

Package Drawing

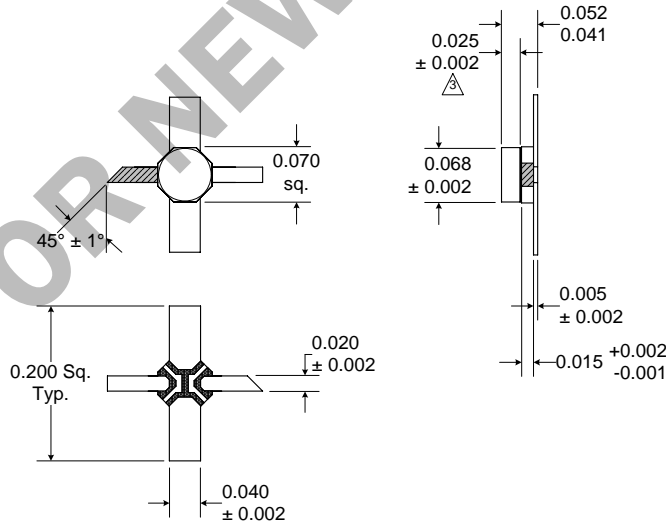

- NOTES:
1. Shaded lead is pin 1.
 2. Darkened areas are metallization.
 3. Dimension applies to ceramic lid minus epoxy coating.

Application Schematic

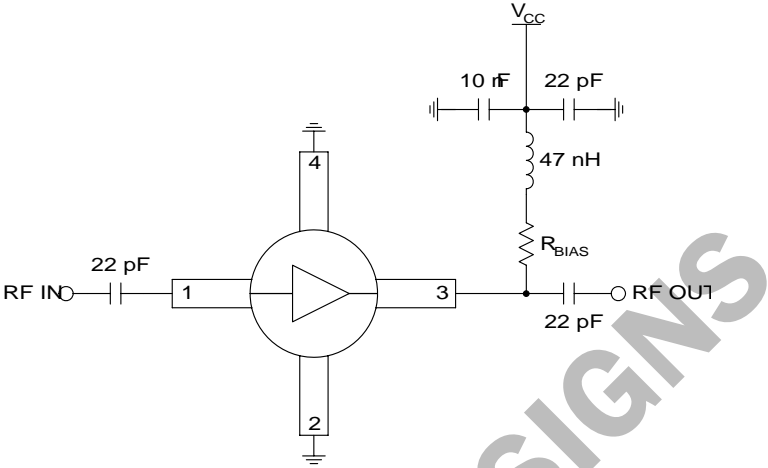

NOT FOR NEW DESIGNS

Evaluation Board Schematic

(Download [Bill of Materials](http://www.rfmd.com) from www.rfmd.com.)

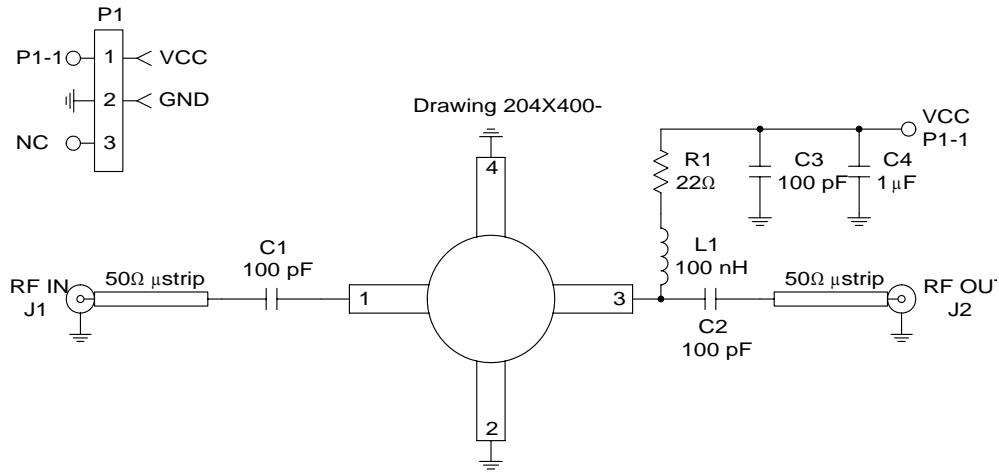

Evaluation Board Layout
Board Size 1.195" x 1.000"

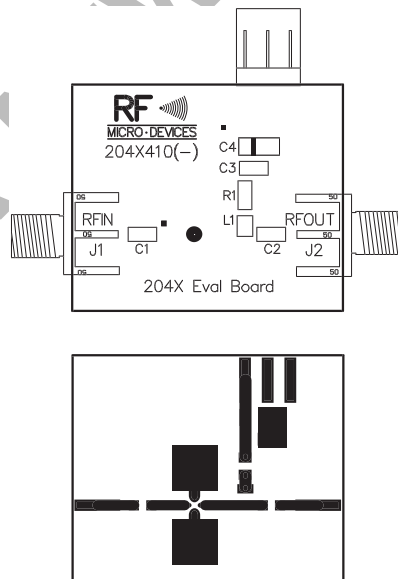

Gain versus Frequency Across Temperature

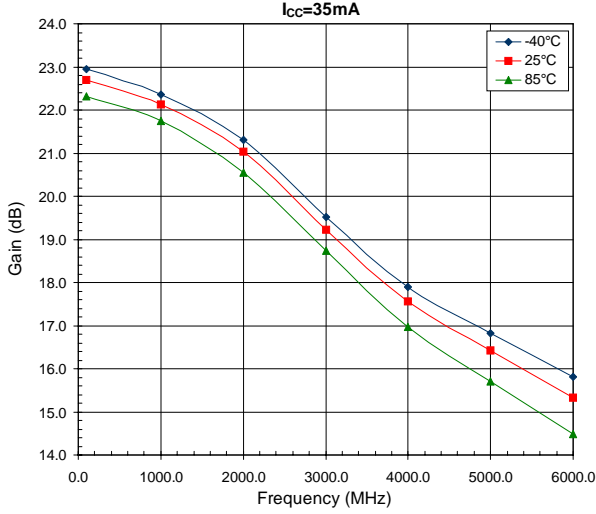

Output P1dB versus Frequency Across Temperature

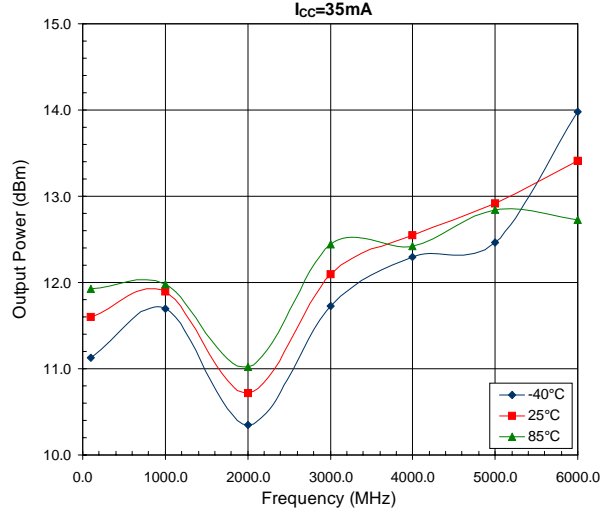

Output IP3 versus Frequency Across Temperature

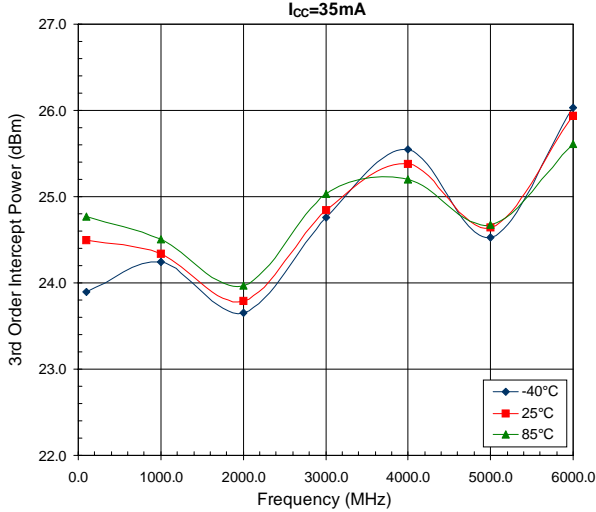

Noise Figure versus Frequency Across Temperature

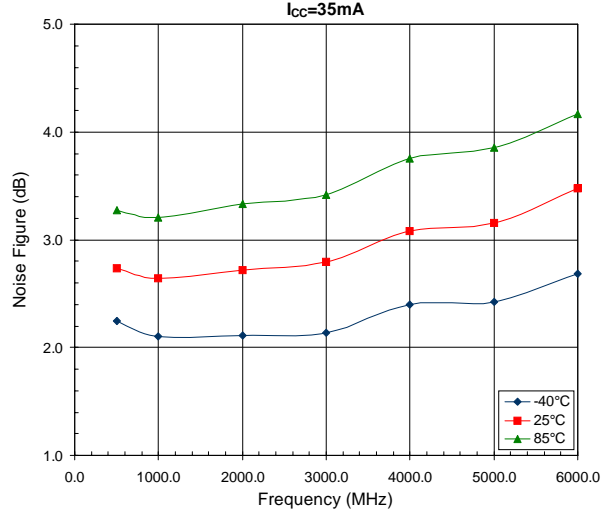

Input VSWR versus Frequency Across Temperature

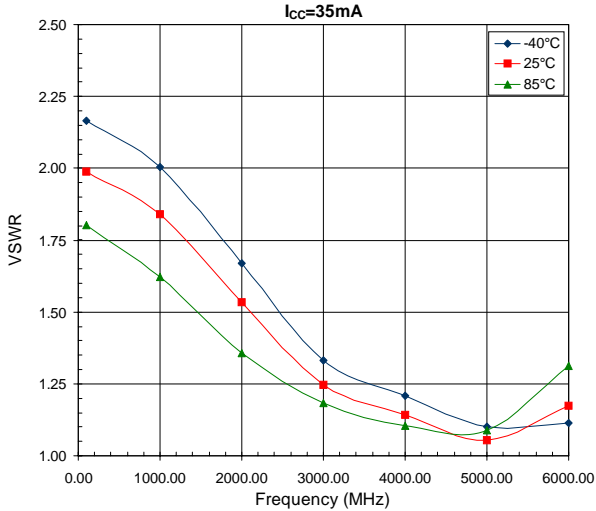

Output VSWR versus Frequency Across Temperature

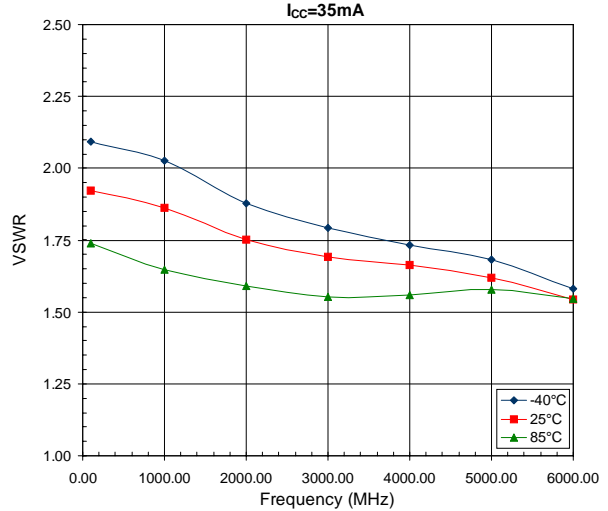

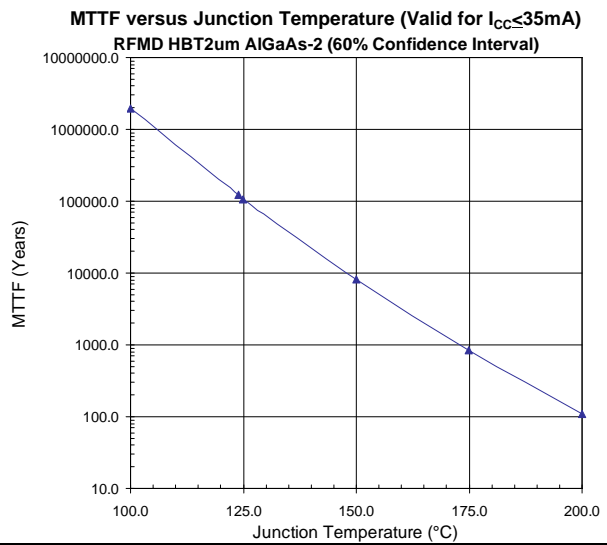
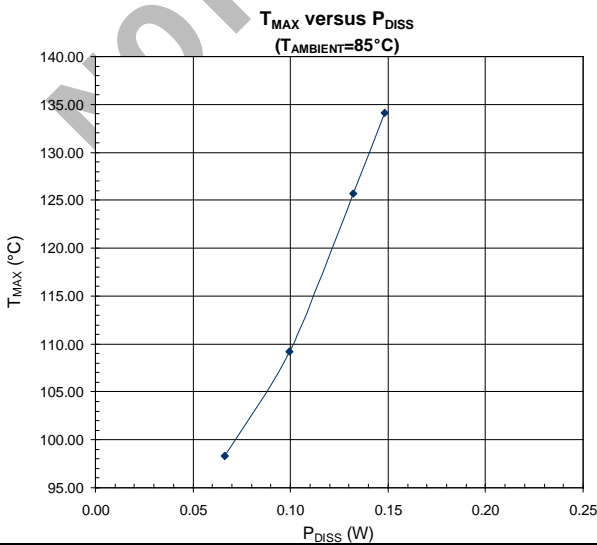
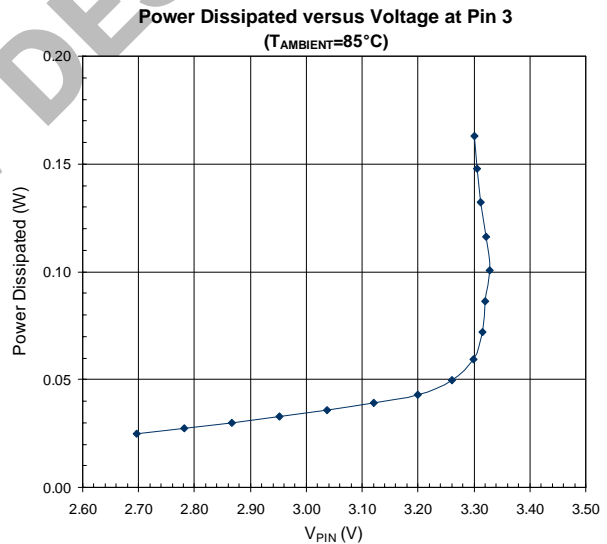
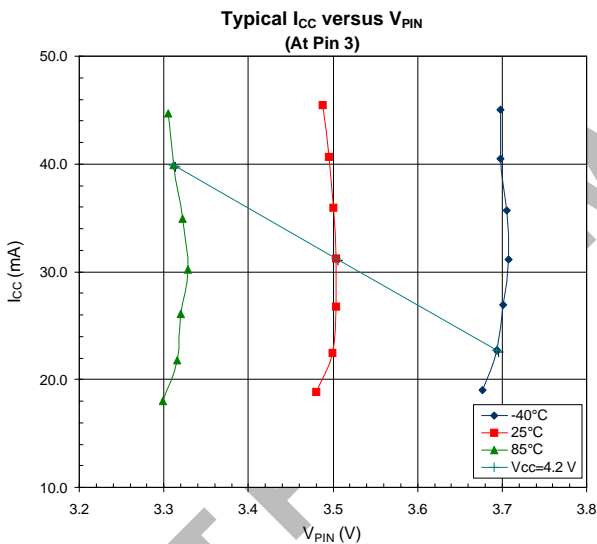
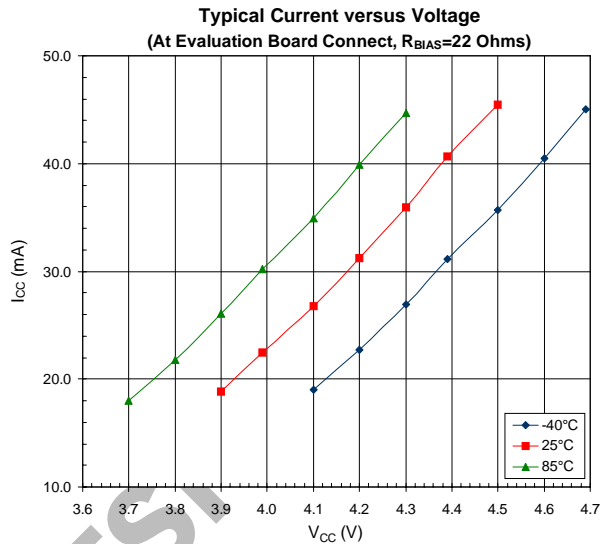
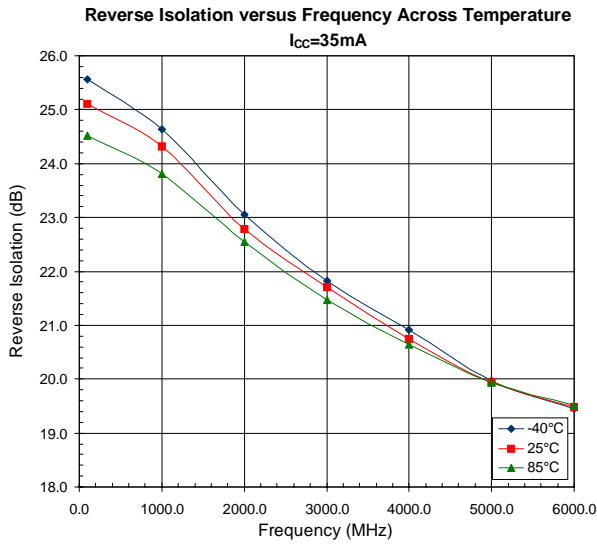

PCB Solder Mask Pattern

Liquid Photo-Imageable (LPI) solder mask is recommended. The solder mask footprint will match what is shown for the PCB metal land pattern with a 2mil to 3mil expansion to accommodate solder mask registration clearance around all pads. The center-grounding pad shall also have a solder mask clearance. Expansion of the pads to create solder mask clearance can be provided in the master data or requested from the PCB fabrication supplier.

A = 2.06 x 1.30 Typ.
B = 0.79 x 2.06 Typ.

Dimensions in mm.

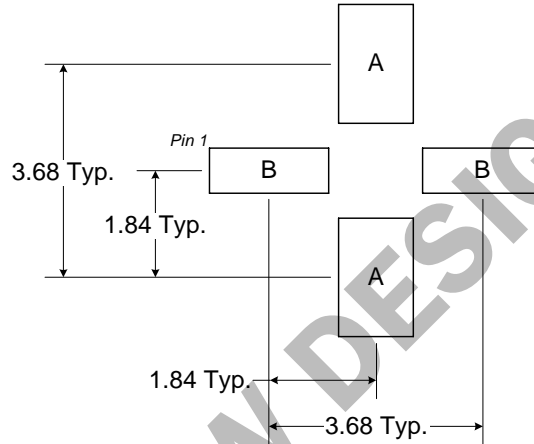



Figure 2. PCB Solder Mask - RF204X (Top View)

NOT FOR NEW DESIGNS

NOT FOR NEW DESIGNS

Looking for pricing, stock, or lifecycle information?

Click below to explore more details on WIN SOURCE:

-  [View RF2046TR7 on WIN SOURCE](#)
-  [RF Micro Devices Information](#)

Optimize Your Supply Chain with WIN SOURCE Solutions

-  Global Sourcing Solution
-  Obsolete Management
-  Cost Control Management
-  Shortage Management
-  Alternative Solution
-  Excess Inventory Management