

## RL78/G10

R01DS0207EJ0100

### RENESAS MCU

Rev.1.00

Apr 15, 2013

True Low Power Platform (as low as 46  $\mu$ A/MHz), 2.0 to 5.5V Operation,  
1 to 4 Kbyte Flash for General Purpose Applications

## 1. OUTLINE

### 1.1 Features

#### Ultra-Low Power Technology

- 2.0 to 5.5 V operation from a single supply
- Stop (RAM retained): 0.56  $\mu$ A
- Operating: 46  $\mu$ A /MHz

#### RL78-S1 Core

- Instruction execution: 78 % of instructions can be executed in 1 to 2 clock cycles
- CISC architecture (Harvard) with 3-stage pipeline
- Multiply: 8 x 8 to 16-bit result in 2 clock cycles
- 16-bit barrel shifter for shift & rotate in 2 clock cycle
- 1-wire on-chip debug function

#### Main Flash Memory

- Density: 1 to 4 Kbyte
- Flash memory rewritable voltage: 4.5 to 5.5 V

#### RAM

- 128 to 512 Byte size options
- Supports operands or instructions
- Back-up retention in all modes

#### High-speed On-chip Oscillator

- 20 MHz with +/-2 % accuracy over voltage (2.0 to 5.5 V) and temperature (-20 to +85°C)
- Pre-configured settings: 20 MHz, 10 MHz, 5 MHz, 2.5 MHz, and 1.25 MHz

#### Reset and Supply Management

- Selectable power-on reset (SPOR) generator with 4 setting options

#### Multiple Communication Interfaces

- 1 x I<sup>2</sup>C master
- 1 x I<sup>2</sup>C multi-master (only for 16-pin product)
- 1 x UART (7-, 8-bit)
- Up to 2 x CSI/SPI (7-, 8-bit)

#### Extended-Function Timers

- Multi-function 16-bit timers: Up to 4 channels
- Interval timer: 12-bit, 1 channel (only for 16-pin product)
- 15 kHz watchdog timer : 1 channel

#### Rich Analog

- ADC: Up to 8 channels, 10-bit resolution, 3.4  $\mu$ s conversion time
- Supports 2.4 V
- 1 x comparator (only for 16-pin product)

#### Safety Features

- Detects execution of illegal instruction
- Detects watchdog timer program loop

#### General Purpose I/O

- High-current (up to 20 mA per pin)
- Open-drain, internal pull-up support

#### External Interrupt

- External interrupt input: 4
- Key interrupt input: 6

#### Operating Ambient Temperature

- Standard: -40 to +85°C

#### Package Type and Pin Count

- SSOP: 10 and 16 pin

\* There is difference in specifications between every product.  
Please refer to specification for details.

## ○ ROM, RAM capacities

Flash ROM	RAM	10 pins	16 pins
4 KB	512 B	–	R5F10Y47ASP <sup>Note 2</sup>
2 KB	256 B	R5F10Y16ASP	R5F10Y46ASP <sup>Note 2</sup>
1 KB	128 B	R5F10Y14ASP	R5F10Y44ASP <sup>Note 2</sup>

- Notes**
1. 16-pin products only
  2. Under development

**Remark** The functions mounted depend on the product. See **1.6 Outline of Functions**.

1.2 List of Part Number

Figure 1-1. Classification of Part Number

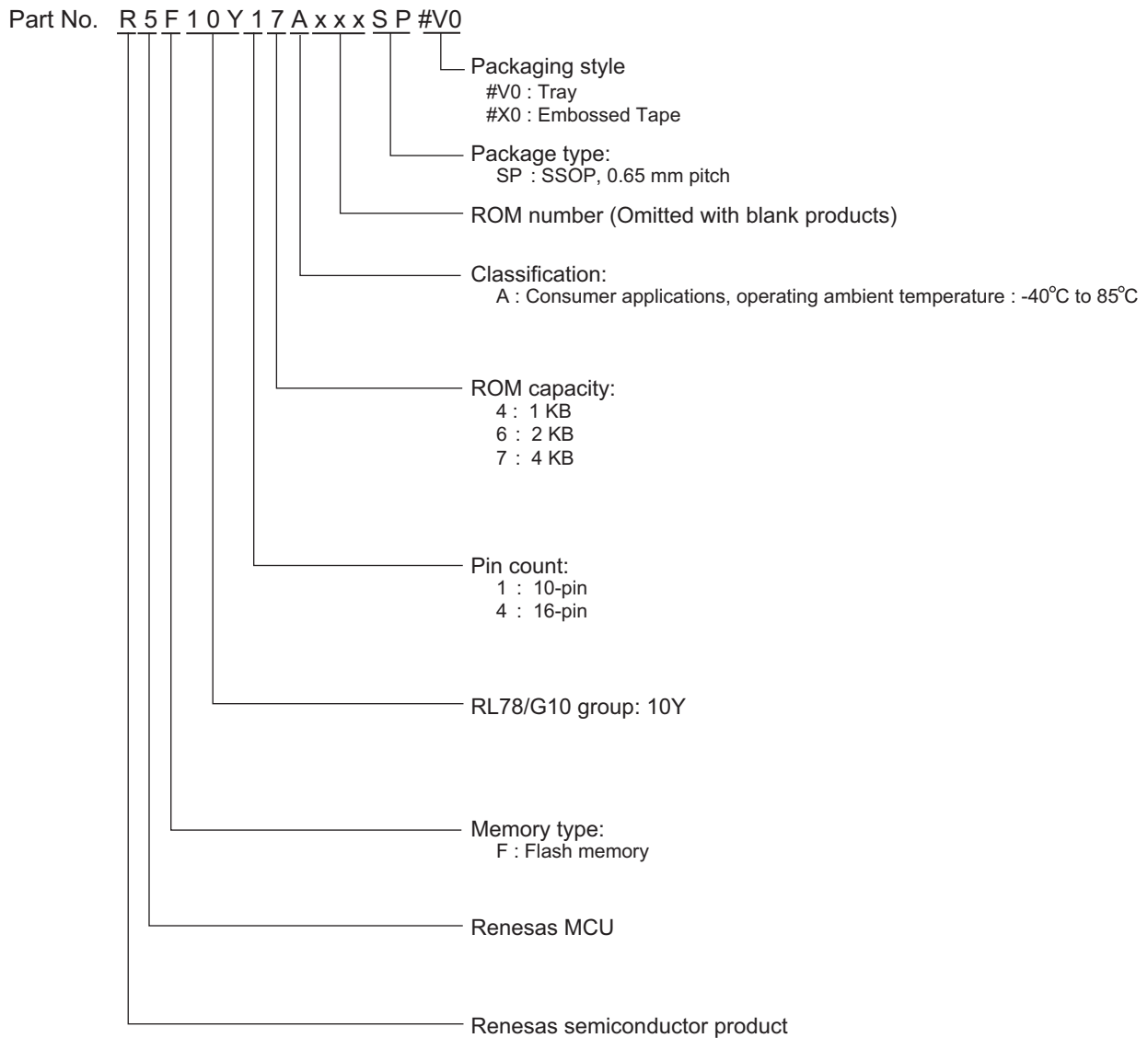

Pin count	Package	Part Number
10 pins	10-pin plastic LSSOP (4.4 × 3.6 mm, 0.65mmpitch)	R5F10Y16ASP#V0, R5F10Y16ASP#X0
		R5F10Y14ASP#V0, R5F10Y14ASP#X0
16 pins	16-pin plastic SSOP (4.4 × 5.0 mm, 0.65mmpitch)	R5F10Y47ASP <sup>Note</sup>
		R5F10Y46ASP <sup>Note</sup>
		R5F10Y44ASP <sup>Note</sup>

**Note** Under development

**Caution** The part number represents the number at the time of publication.

Be sure to review the latest part number through the target product page in the Renesas Electronics Corp.website.

### 1.3 Pin Configuration (Top View)

#### 1.3.1 10-pin products

- 10-pin plastic LSSOP (4.4 × 3.6)

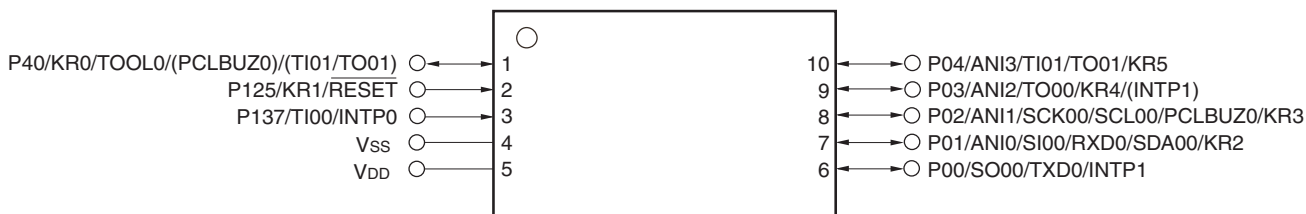

- Remarks 1.** For pin identification, see 1.4 Pin Identification.
- 2.** Functions in parentheses in the above figure can be assigned via settings in the peripheral I/O redirection register (PIOR).

#### 1.3.2 16-pin products

- 16-pin plastic SSOP (4.4 × 5.0)

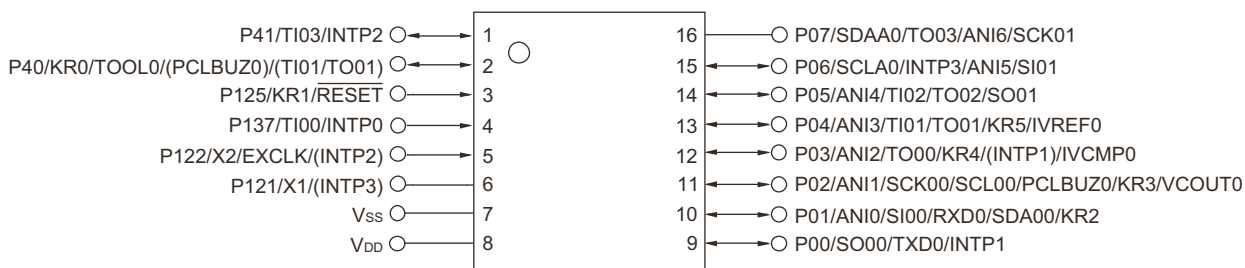

- Remarks 1.** For pin identification, see 1.4 Pin Identification.
- 2.** Functions in parentheses in the above figure can be assigned via settings in the peripheral I/O redirection register (PIOR).

## 1.4 Pin Identification

ANI0 to ANI6	: Analog Input
INTP0 to INTP3	: External Interrupt Input
KR0 to KR5	: Key Return
P00 to P07	: Port 0
P40, P41	: Port 4
P121, P122, P125	: Port 12
P137	: Port 13
PCLBUZ0	: Programmable Clock Output/ Buzzer Output
EXCLK	: External Clock Input
X1, X2	: Crystal Oscillator
IVCMP0	: Comparator Input
VCOUT0	: Comparator Output
IVREF0	: Comparator Reference Input
$\overline{\text{RESET}}$	: Reset
RxD0	: Receive Data
SCK00, SCK01	: Serial Clock Input/Output
SCL00, SCLA0	: Serial Clock Output
SDA00, SDAA0	: Serial Data Input/Output
SI00, SI01	: Serial Data Input
SO00, SO01	: Serial Data Output
TI00 to TI03	: Timer Input
TO00 to TO03	: Timer Output
TOOL0	: Data Input/Output for Tool
TxD0	: Transmit Data
V <sub>DD</sub>	: Power Supply
V <sub>SS</sub>	: Ground

### 1.5 Block Diagram

#### 1.5.1 10-pin products

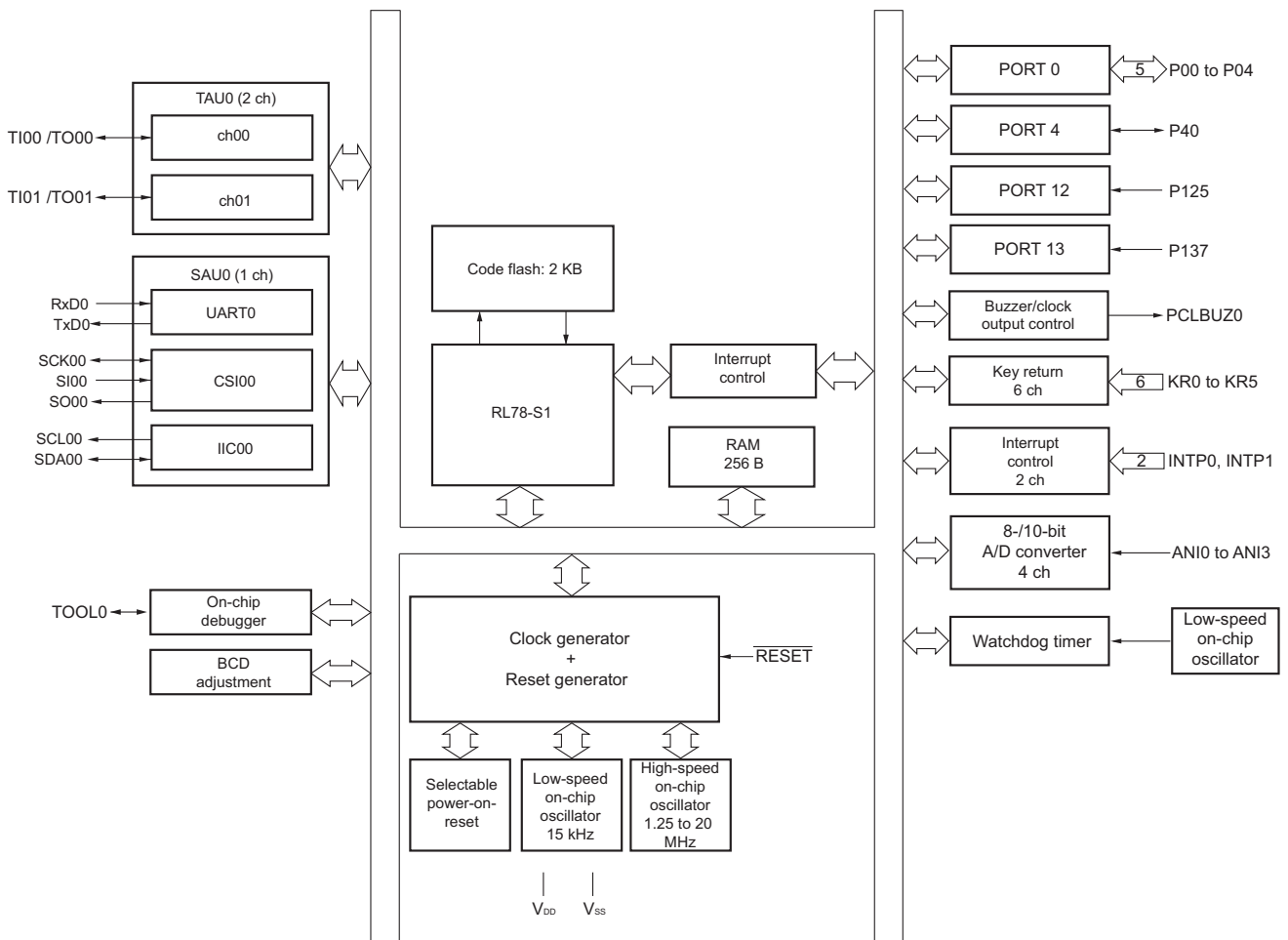

1.5.2 16-pin products

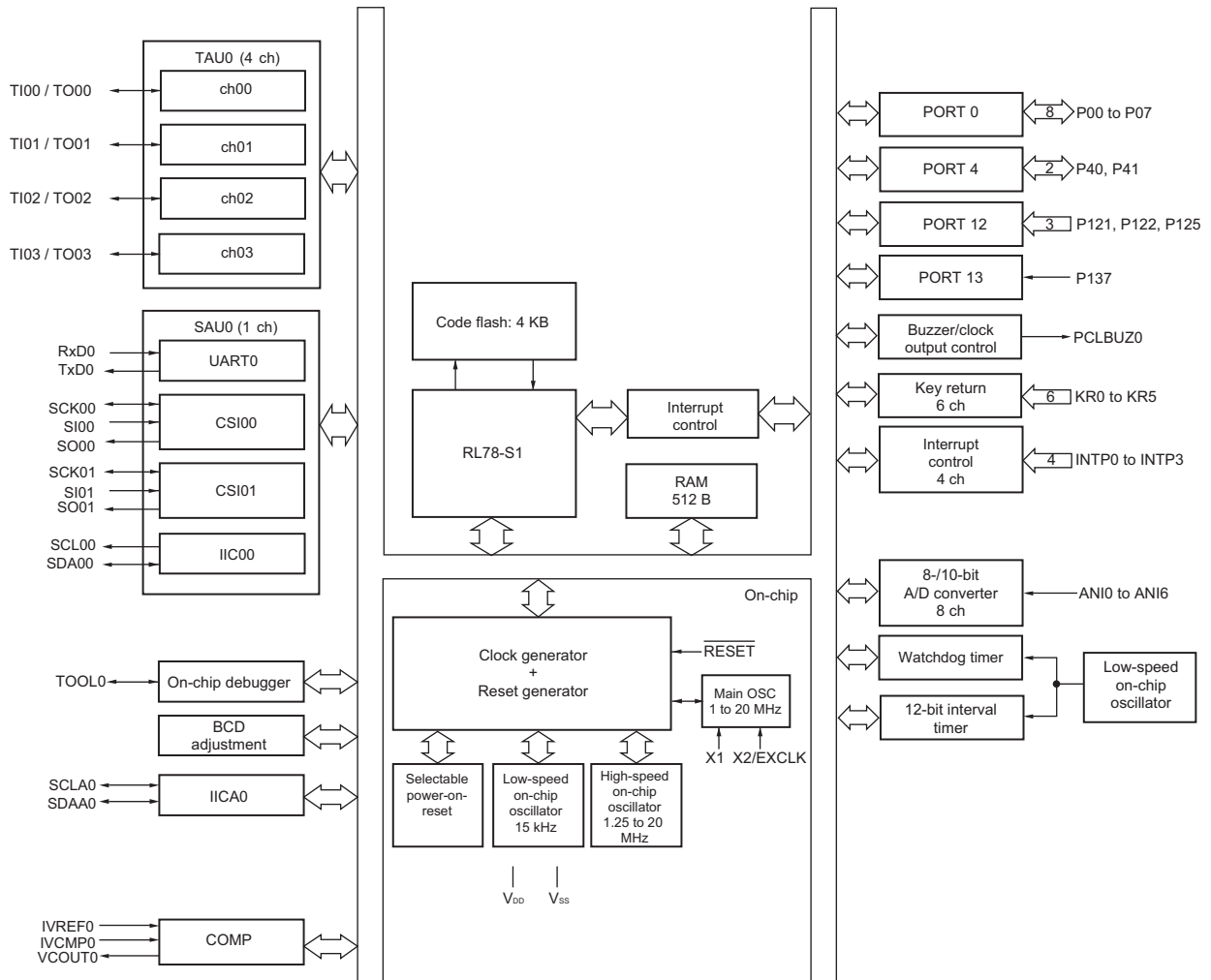

## 1.6 Outline of Functions

This outline describes the function at the time when Peripheral I/O redirection register (PIOR) is set to 00H.

Item		10-pin		16-pin		
		R5F10Y16ASP	R5F10Y14ASP	R5F10Y47ASP	R5F10Y46ASP	R5F10Y44ASP
Code flash memory		2 KB	1 KB	4 KB	2 KB	1 KB
RAM		256 B	128 B	512 B	256 B	128 B
Main system clock	High-speed system clock	—		X1, X2 (crystal/ceramic) oscillation, external main system clock input (EXCLK): 1 to 20 MHz: V <sub>DD</sub> = 2.7 to 5.5 V 1 to 5 MHz: V <sub>DD</sub> = 2.0 to 5.5 V		
	High-speed on-chip oscillator clock	<ul style="list-style-type: none"> <li>• 1.25 to 20 MHz (V<sub>DD</sub> = 2.7 to 5.5 V)</li> <li>• 1.25 to 5 MHz (V<sub>DD</sub> = 2.0 to 5.5 V)</li> </ul>				
Low-speed on-chip oscillator clock		15 kHz (TYP)				
General-purpose register		8-bit register × 8				
Minimum instruction execution time		0.05 μs (20 MHz operation)				
Instruction set		<ul style="list-style-type: none"> <li>• Data transfer (8 bits)</li> <li>• Adder and subtractor/logical operation (8 bits)</li> <li>• Multiplication (8 bits × 8 bits)</li> <li>• Rotate, barrel shift, and bit manipulation (set, reset, test, and Boolean operation), etc.</li> </ul>				
I/O port	Total	8		14		
	CMOS I/O	6 (N-ch open-drain output (V <sub>DD</sub> tolerance): 2)		10 (N-ch open-drain output (V <sub>DD</sub> tolerance): 4)		
	CMOS input	2		4		
Timer	16-bit timer	2 channels		4 channels		
	Watchdog timer	1 channel				
	12-bit interval timer	—		1 channel		
	Timer output	2 channels (PWM output: 1)		4 channels (PWM outputs: 3 <sup>Note 1</sup> )		
Clock output/buzzer output		1				
		2.44 kHz to 10 MHz: (Peripheral hardware clock: f <sub>MAIN</sub> = 20 MHz operation)				
Comparator		—		1		
8-/10-bit resolution A/D converter		4 channels		8 channels		
Serial interface		[10-pin products] CSI: 1 channel/simplified I <sup>2</sup> C: 1 channel/UART: 1 channel				
		[16-pin products] CSI: 2 channels/simplified I <sup>2</sup> C: 1 channel/UART: 1 channel				
	I <sup>2</sup> C bus	—		1 channel		
Vectored interrupt sources	Internal	8		14		
	External	3		5		
Key interrupt		6				
Reset		<ul style="list-style-type: none"> <li>• Reset by <math>\overline{\text{RESET}}</math> pin</li> <li>• Internal reset by watchdog timer</li> <li>• Internal reset by selectable power-on-reset</li> <li>• Internal reset by illegal instruction execution <sup>Note 2</sup></li> <li>• Internal reset by data retention lower limit voltage</li> </ul>				
Selectable power-on-reset circuit		Detection voltage: 2.0 V/2.4 V/2.7 V/4.0 V				
On-chip debug function		Provided				
Power supply voltage		V <sub>DD</sub> = 2.0 to 5.5 V				
Operating ambient temperature		T <sub>A</sub> = - 40 to + 85 °C				

- Notes**
1. The number of outputs varies, depending on the setting of channels in use and the number of the master (see **6.8.3 Operation as multiple PWM output function in the RL78/G10 User's Manual**).
  2. The illegal instruction is generated when instruction code FFH is executed. Reset by the illegal instruction execution not issued by emulation with the on-chip debug emulator.

## 2. ELECTRICAL SPECIFICATIONS

- Cautions**
1. This chapter explains the electrical specifications of two products, the R5F10Y16ASP and the R5F10Y14ASP.
  2. Electrical specifications for the 16-pin products are T. B. D. because these products are under development.
  3. The RL78/G10 has an on-chip debug function, which is provided for development and evaluation. Do not use the on-chip debug function in products designated for mass production, because the guaranteed number of rewritable times of the flash memory may be exceeded when this function is used, and product reliability therefore cannot be guaranteed. Renesas Electronics is not liable for problems occurring when the on-chip debug function is used.
  4. The pins mounted depend on the product. Refer to 2.1 Port Functions and 2.2.1 Functions for each product in the RL78/G10 User's Manual.

## 2.1 Absolute Maximum Ratings

( $T_A = 25^\circ\text{C}$ )

Parameter	Symbols	Conditions	Ratings	Unit	
Supply Voltage	$V_{DD}$		-0.5 to +6.5	V	
Input Voltage	$V_{I1}$		-0.3 to $V_{DD} + 0.3$ <sup>Note</sup>	V	
Output Voltage	$V_{O1}$		-0.3 to $V_{DD} + 0.3$	V	
Output current, high	$I_{OH1}$	Per pin	-40	mA	
		Total of all pins -140 mA	P40	-40	mA
			P00 to P04	-100	mA
Output current, low	$I_{OL1}$	Per pin	40	mA	
		Total of all pins 140 mA	P40	40	mA
			P00 to P04	100	mA
Operating ambient temperature	$T_A$		-40 to +85	$^\circ\text{C}$	
Storage temperature	$T_{stg}$		-65 to +150	$^\circ\text{C}$	

**Note** Must be 6.5 V or lower.

**Caution** Product quality may suffer if the absolute maximum rating is exceeded even momentarily for any parameter. That is, the absolute maximum ratings are rated values at which the product is on the verge of suffering physical damage, and therefore the product must be used under conditions that ensure that the absolute maximum ratings are not exceeded.

**Remarks**

1. Unless specified otherwise, the characteristics of alternate-function pins are the same as those of the port pins.
2. The reference voltage is  $V_{SS}$ .

## 2.2 Oscillator Characteristics

### 2.2.1 On-chip oscillator characteristics

( $T_A = -40$  to  $+85^\circ\text{C}$ ,  $2.0\text{ V} \leq V_{DD} \leq 5.5\text{ V}$ ,  $V_{SS} = 0\text{ V}$ )

Oscillators	Parameters	Conditions	MIN.	TYP.	MAX.	Unit
High-speed on-chip oscillator oscillation clock frequency <sup>Notes 1, 2</sup>	$f_{IH}$		1.25		20	MHz
High-speed on-chip oscillator oscillation clock frequency accuracy		$T_A = -20$ to $+85^\circ\text{C}$	-2.0		+2.0	%
		$T_A = -40$ to $-20^\circ\text{C}$	-3.0		+3.0	%
Low-speed on-chip oscillator oscillation clock frequency <sup>Note 3</sup>	$f_{IL}$			15		kHz
Low-speed on-chip oscillator oscillation clock frequency accuracy			-15		+15	%

**Notes**

1. High-speed on-chip oscillator frequency is selected by bits 0 to 2 of option byte (000C2H).
2. This only indicates the oscillator characteristics. Refer to AC Characteristics for instruction execution time.
3. This only indicates the oscillator characteristics.

## 2.3 DC Characteristics

### 2.3.1 Pin characteristics

( $T_A = -40$  to  $+85^\circ\text{C}$ ,  $2.0\text{ V} \leq V_{DD} \leq 5.5\text{ V}$ ,  $V_{SS} = 0\text{ V}$ )

Parameter	Symbol	Conditions		MIN.	TYP.	MAX.	Unit
Output current, high <sup>Note 1</sup>	I <sub>OH1</sub>	P00, P01, P02 to P04, P40	Per pin			-10.0 <sup>Note 2</sup>	mA
		P40	Total <sup>Note 3</sup>	4.0 V ≤ V <sub>DD</sub> ≤ 5.5 V		-10.0	mA
				2.7 V ≤ V <sub>DD</sub> < 4.0 V		-2.0	mA
				2.0 V ≤ V <sub>DD</sub> < 2.7 V		-1.5	mA
		P00, P01, P02 to P04	Total <sup>Note 3</sup>	4.0 V ≤ V <sub>DD</sub> ≤ 5.5 V		-50.0	mA
				2.7 V ≤ V <sub>DD</sub> < 4.0 V		-10.0	mA
				2.0 V ≤ V <sub>DD</sub> < 2.7 V		-7.5	mA
Total of all pins <sup>Note 3</sup>						-60.0	mA
Output current, low <sup>Note 4</sup>	I <sub>OL1</sub>	P00 to P04, P40	Per pin			20.0 <sup>Note 2</sup>	mA
		P40	Total <sup>Note 3</sup>	4.0 V ≤ V <sub>DD</sub> ≤ 5.5 V		20.0	mA
				2.7 V ≤ V <sub>DD</sub> < 4.0 V		3.0	mA
				2.0 V ≤ V <sub>DD</sub> < 2.7 V		0.6	mA
		P00 to P04	Total <sup>Note 3</sup>	4.0 V ≤ V <sub>DD</sub> ≤ 5.5 V		80.0	mA
				2.7 V ≤ V <sub>DD</sub> < 4.0 V		12.0	mA
				2.0 V ≤ V <sub>DD</sub> < 2.7 V		2.4	mA
Total of all pins <sup>Note 3</sup>						100.0	mA
Input voltage, high	V <sub>IH1</sub>			0.8 V <sub>DD</sub>		V <sub>DD</sub>	V
Input voltage, low	V <sub>IL1</sub>			0		0.2 V <sub>DD</sub>	V
Output voltage, high <sup>Note 5</sup>	V <sub>OH1</sub>	4.0 V ≤ V <sub>DD</sub> ≤ 5.5 V	I <sub>OH</sub> = -10 mA	V <sub>DD</sub> -1.5			V
			I <sub>OH</sub> = -3.0 mA	V <sub>DD</sub> -0.7			V
		2.7 V ≤ V <sub>DD</sub> ≤ 5.5 V	I <sub>OH</sub> = -2.0 mA	V <sub>DD</sub> -0.6			V
		2.0 V ≤ V <sub>DD</sub> ≤ 5.5 V	I <sub>OH</sub> = -1.5 mA	V <sub>DD</sub> -0.5			V
Output voltage, low <sup>Note 6</sup>	V <sub>OL1</sub>	4.0 V ≤ V <sub>DD</sub> ≤ 5.5 V	I <sub>OL</sub> = 20 mA			1.3	V
			I <sub>OL</sub> = 8.5 mA			0.7	V
		2.7 V ≤ V <sub>DD</sub> ≤ 5.5 V	I <sub>OL</sub> = 3.0 mA			0.6	V
			I <sub>OL</sub> = 1.5 mA			0.4	V
2.0 V ≤ V <sub>DD</sub> ≤ 5.5 V	I <sub>OL</sub> = 0.6 mA			0.4	V		
Input leakage current, high	I <sub>LIH1</sub>	V <sub>I</sub> = V <sub>DD</sub>				1	μA
Input leakage current, low	I <sub>LIL1</sub>	V <sub>I</sub> = V <sub>SS</sub>				-1	μA
On-chip pull-up resistance	R <sub>U</sub>	V <sub>I</sub> = V <sub>SS</sub>		10	20	100	kΩ

- Notes**
- Value of current at which the device operation is guaranteed even if the current flows from the V<sub>DD</sub> pin to an output pin.
  - Do not exceed the total current value.
  - This is the output current value under conditions where the duty factor ≤ 70%.  
The output current value when the duty factor > 70% can be calculated with the following expression (when changing the duty factor to n%).

- Total output current of pins =  $(I_{OH} \times 0.7)/(n \times 0.01)$   
<Example> Where  $n = 80\%$  and  $I_{OH} = -10.0\text{ mA}$   
Total output current of pins =  $(-10.0 \times 0.7)/(80 \times 0.01) \cong -8.7\text{ mA}$
- Total output current of pins =  $(I_{OL} \times 0.7)/(n \times 0.01)$   
<Example> Where  $n = 80\%$  and  $I_{OL} = 10.0\text{ mA}$   
Total output current of pins =  $(10.0 \times 0.7)/(80 \times 0.01) \cong 8.7\text{ mA}$

However, the current that is allowed to flow into one pin does not vary depending on the duty factor. A current higher than the absolute maximum rating must not flow into one pin.

4. Value of current at which the device operation is guaranteed even if the current flows from an output pin to the  $V_{SS}$  pin.
5. The value under the condition which satisfies the high-level output current ( $I_{OH1}$ ).
6. The value under the condition which satisfies the low-level output current ( $I_{OL1}$ ).

**Cautions 1. P00 and P01 do not output high level in N-ch open-drain mode.**

2. **The maximum value of  $V_{IH}$  of P00 and P01 is  $V_{DD}$  even in N-ch open-drain mode.**

**Remark** Unless specified otherwise, the characteristics of alternate-function pins are the same as those of the port.

### 2.3.2 Supply current characteristics

( $T_A = -40$  to  $+85^\circ\text{C}$ ,  $2.0\text{ V} \leq V_{DD} \leq 5.5\text{ V}$ ,  $V_{SS} = 0\text{ V}$ )

Parameter	Symbol	Conditions				MIN.	TYP.	MAX.	Unit
Supply current <small>Note 1</small>	I <sub>DD1</sub>	Operating mode	Basic operation	f <sub>IH</sub> = 20 MHz	V <sub>DD</sub> = 3.0 V, 5.0 V		0.91		mA
			Normal operation	f <sub>IH</sub> = 20 MHz	V <sub>DD</sub> = 3.0 V, 5.0 V		1.57	2.04	
				f <sub>IH</sub> = 5 MHz	V <sub>DD</sub> = 3.0 V, 5.0 V		0.85	1.15	
	I <sub>DD2</sub> <small>Note 2</small>	HALT mode		f <sub>IH</sub> = 20 MHz	V <sub>DD</sub> = 3.0 V, 5.0 V		350	820	μA
				f <sub>IH</sub> = 5 MHz	V <sub>DD</sub> = 3.0 V, 5.0 V		290	600	
I <sub>DD3</sub> <small>Note 3</small>	STOP mode	V <sub>DD</sub> = 3.0 V				0.56	2.00	μA	
WDT supply current <small>Note 4</small>	I <sub>WDT</sub>	f <sub>IL</sub> = 15 kHz					0.31		μA
ADC supply current <small>Note 5</small>	I <sub>ADC</sub>	During conversion at the highest speed	V <sub>DD</sub> = 5.0 V				1.30	1.90	mA
			V <sub>DD</sub> = 3.0 V				0.50		

- Notes**
- Total current flowing into V<sub>DD</sub>, including the input leakage current flowing when the level of the input pin is fixed to V<sub>DD</sub> or V<sub>SS</sub>. The values below the MAX. column include the peripheral operation current. However, not including the current flowing into the watchdog timer, A/D converter, I/O port, and on-chip pull-up/pull-down resistors.
  - During HALT instruction execution by flash memory.
  - When the high-speed on-chip oscillator is stopped.
  - Current flowing only to the watchdog timer (including the operating current of the low-speed on-chip oscillator). The current value of the RL78 microcontrollers is the sum of I<sub>DD1</sub>, I<sub>DD2</sub> or I<sub>DD3</sub> and I<sub>WDT</sub> when the watchdog timer operates.
  - Current flowing only to the A/D converter. The current value of the RL78 microcontrollers is the sum of I<sub>DD1</sub> or I<sub>DD2</sub> and I<sub>ADC</sub> when the A/D converter operates in an operation mode or the HALT mode.

- Remarks**
- f<sub>IL</sub>: Low-speed on-chip oscillator clock frequency
  - f<sub>IH</sub>: High-speed on-chip oscillator clock frequency
  - Temperature condition of the TYP. value is T<sub>A</sub> = 25°C

2.4 AC Characteristics

( $T_A = -40$  to  $+85^\circ\text{C}$ ,  $2.0\text{ V} \leq V_{DD} \leq 5.5\text{ V}$ ,  $V_{SS} = 0\text{ V}$ )

Items	Symbol	Conditions	MIN.	TYP.	MAX.	Unit	
Instruction cycle (minimum instruction execution time)	$T_{CY}$	Main system clock ( $f_{MAIN}$ ) operation	$2.7\text{ V} \leq V_{DD} \leq 5.5\text{ V}$	0.05		0.8	$\mu\text{s}$
			$2.0\text{ V} \leq V_{DD} \leq 5.5\text{ V}$	0.2		0.8	$\mu\text{s}$
TI00, TI01 input high-level width, low-level width	$t_{TH}, t_{TL}$	Noise filter is not used	$1/f_{MCK} + 10$			ns	
TO00, TO01 output frequency	$f_{TO}$	$4.0\text{ V} \leq V_{DD} \leq 5.5\text{ V}$			10	MHz	
		$2.7\text{ V} \leq V_{DD} < 4.0\text{ V}$			5	MHz	
		$2.0\text{ V} \leq V_{DD} < 2.7\text{ V}$			2.5	MHz	
PCLBUZ0 output frequency	$f_{PCL}$	$4.0\text{ V} \leq V_{DD} \leq 5.5\text{ V}$			10	MHz	
		$2.7\text{ V} \leq V_{DD} < 4.0\text{ V}$			5	MHz	
		$2.0\text{ V} \leq V_{DD} < 2.7\text{ V}$			2.5	MHz	
RESET low-level width	$t_{RSL}$		10			$\mu\text{s}$	

**Remark**  $f_{MCK}$ : Timer array unit operation clock frequency

AC Timing Test Points

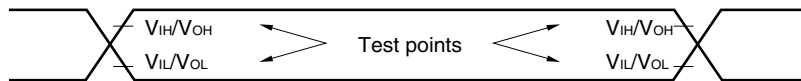

TI/TO Timing

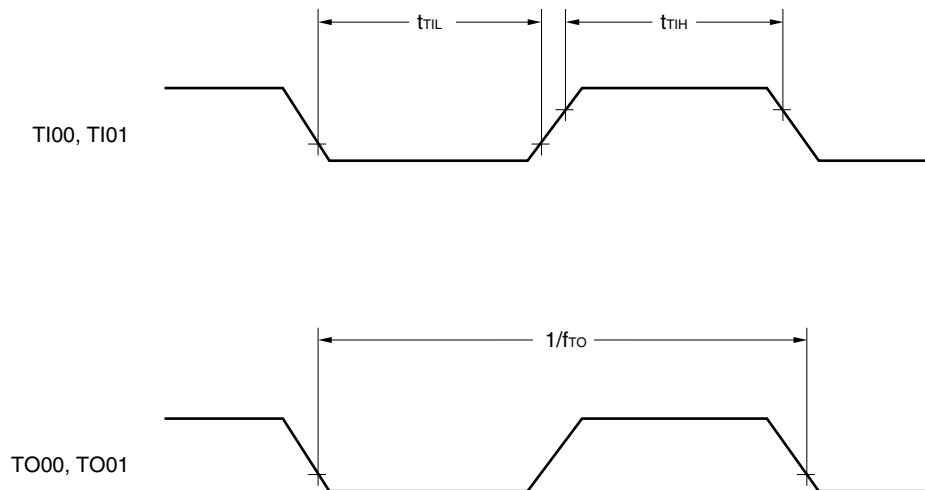

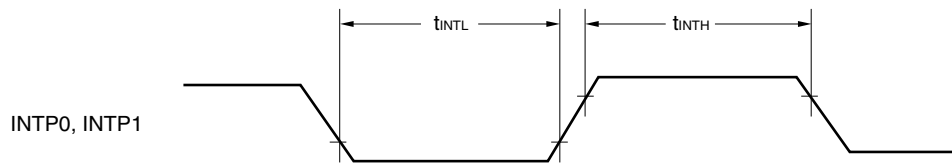
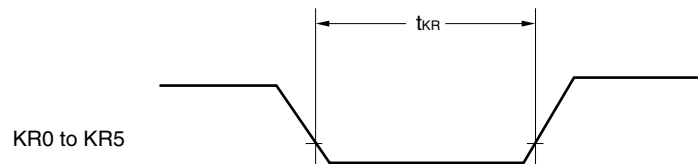
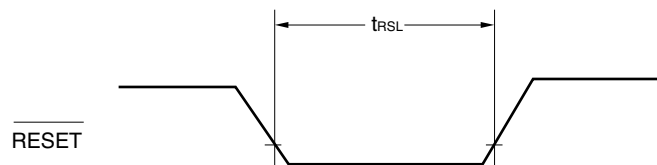
**Interrupt Request Input Timing****Key Interrupt Input Timing** **$\overline{\text{RESET}}$  Input Timing**

## 2.5 Serial Communication Characteristics

### 2.5.1 Serial array unit

#### (1) UART mode

( $T_A = -40$  to  $+85^\circ\text{C}$ ,  $2.0\text{ V} \leq V_{DD} \leq 5.5\text{ V}$ ,  $V_{SS} = 0\text{ V}$ )

Parameter	Symbol	Conditions	MIN.	TYP.	MAX.	Unit
Transfer rate					$f_{mck}/6$	bps
		Theoretical value of the maximum transfer rate $f_{CLK} = f_{mck} = 20\text{ MHz}$			3.3	Mbps

#### UART mode connection diagram

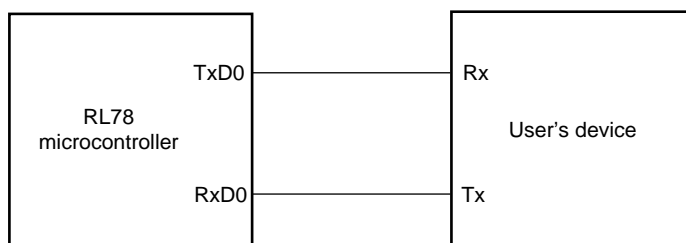

#### UART mode bit width (reference)

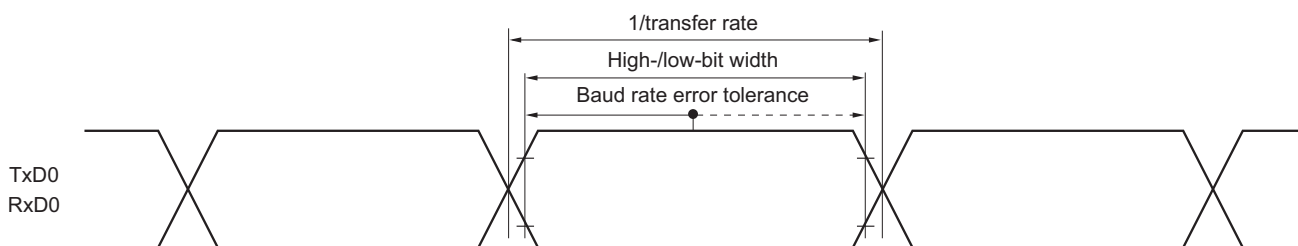

**Remark**  $f_{mck}$ : Serial array unit operation clock frequency  
 (Operation clock to be set by the CKSmn bit of serial mode register mn (SMRmn).  
 m: Unit number, n: Channel number (mn = 00))

**(2) CSI mode (master mode, SCKp... internal clock output)****( $T_A = -40$  to  $+85^\circ\text{C}$ ,  $2.0\text{ V} \leq V_{DD} \leq 5.5\text{ V}$ ,  $V_{SS} = 0\text{ V}$ )**

Parameter	Symbol	Conditions	MIN.	TYP.	MAX.	Unit
SCKp cycle time	$t_{KCY1}$	$t_{KCY1} \geq 4/f_{CLK}$	$2.7\text{ V} \leq V_{DD} \leq 5.5\text{ V}$	200		ns
			$2.0\text{ V} \leq V_{DD} \leq 5.5\text{ V}$	800		ns
SCKp high-/low-level width	$t_{KH1}, t_{KL1}$	$2.7\text{ V} \leq V_{DD} \leq 5.5\text{ V}$	$t_{KCY1}/2-18$			ns
		$2.0\text{ V} \leq V_{DD} \leq 5.5\text{ V}$	$t_{KCY1}/2-50$			ns
Slp setup time (to SCKp $\uparrow$ ) <sup>Note 1</sup>	$t_{SIK1}$	$2.7\text{ V} \leq V_{DD} \leq 5.5\text{ V}$	47			ns
		$2.0\text{ V} \leq V_{DD} \leq 5.5\text{ V}$	110			ns
Slp hold time (from SCKp $\uparrow$ ) <sup>Note 2</sup>	$t_{KSH1}$		19			ns
Delay time from SCKp $\downarrow$ to SOp output <sup>Note 3</sup>	$t_{KSO1}$	$C = 30\text{ pF}$ <sup>Note 4</sup>			25	ns

- Notes**
1. When DAPmn = 0 and CKPmn = 0, or DAPmn = 1 and CKPmn = 1. The Slp setup time becomes “to SCKp $\downarrow$ ” when DAPmn = 0 and CKPmn = 1, or DAPmn = 1 and CKPmn = 0.
  2. When DAPmn = 0 and CKPmn = 0, or DAPmn = 1 and CKPmn = 1. The Slp hold time becomes “from SCKp $\downarrow$ ” when DAPmn = 0 and CKPmn = 1, or DAPmn = 1 and CKPmn = 0.
  3. When DAPmn = 0 and CKPmn = 0, or DAPmn = 1 and CKPmn = 1. The delay time to SOp output becomes “from SCKp $\uparrow$ ” when DAPmn = 0 and CKPmn = 1, or DAPmn = 1 and CKPmn = 0.
  4. C is the load capacitance of the SCKp and SOp output lines.

- Remarks**
1. p: CSI number (p = 00), m: Unit number (m = 0), n: Channel number (n = 0)
  2.  $f_{MCK}$ : Serial array unit operation clock frequency  
(Operation clock to be set by the CKSmn bit of serial mode register mn (SMRmn).  
m: Unit number, n: Channel number (mn = 00))

**(3) CSI mode (slave mode, SCKp... external clock input)****( $T_A = -40$  to  $+85^\circ\text{C}$ ,  $2.0\text{ V} \leq V_{DD} \leq 5.5\text{ V}$ ,  $V_{SS} = 0\text{ V}$ )**

Parameter	Symbol	Conditions	MIN.	TYP.	MAX.	Unit	
SCKp cycle time	$t_{KCY2}$	$2.7\text{ V} \leq V_{DD} \leq 5.5\text{ V}$	$f_{MCK} = 20\text{ MHz}$	$8/f_{MCK}$		ns	
			$f_{MCK} \leq 10\text{ MHz}$	$6/f_{MCK}$		ns	
		$2.0\text{ V} \leq V_{DD} < 2.7\text{ V}$		$6/f_{MCK}$		ns	
SCKp high-/low-level width	$t_{KH2}$ , $t_{KL2}$	$2.0\text{ V} \leq V_{DD} \leq 5.5\text{ V}$	$t_{KCY2}/2$			ns	
Slp setup time (to SCKp $\uparrow$ ) <sup>Note 1</sup>	$t_{SIK2}$	$2.7\text{ V} \leq V_{DD} \leq 5.5\text{ V}$	$1/f_{MCK} + 20$			ns	
		$2.0\text{ V} \leq V_{DD} < 2.7\text{ V}$	$1/f_{MCK} + 30$			ns	
Slp hold time (from SCKp $\uparrow$ ) <sup>Note 2</sup>	$t_{KSI2}$	$2.0\text{ V} \leq V_{DD} \leq 5.5\text{ V}$	$1/f_{MCK} + 31$			ns	
Delay time from SCKp $\downarrow$ to SOP output <sup>Note 3</sup>	$t_{KS02}$	$C = 30\text{ pF}$ <sup>Note 4</sup>	$2.7\text{ V} \leq V_{DD} \leq 5.5\text{ V}$			$2/f_{MCK} + 50$	ns
			$2.0\text{ V} \leq V_{DD} < 2.7\text{ V}$			$2/f_{MCK} + 110$	ns

- Notes**
1. When DAPmn = 0 and CKPmn = 0, or DAPmn = 1 and CKPmn = 1. The Slp setup time becomes “to SCKp $\downarrow$ ” when DAPmn = 0 and CKPmn = 1, or DAPmn = 1 and CKPmn = 0.
  2. When DAPmn = 0 and CKPmn = 0, or DAPmn = 1 and CKPmn = 1. The Slp hold time becomes “from SCKp $\downarrow$ ” when DAPmn = 0 and CKPmn = 1, or DAPmn = 1 and CKPmn = 0.
  3. When DAPmn = 0 and CKPmn = 0, or DAPmn = 1 and CKPmn = 1. The delay time to SOP output becomes “from SCKp $\uparrow$ ” when DAPmn = 0 and CKPmn = 1, or DAPmn = 1 and CKPmn = 0.
  4. C is the load capacitance of the SOP output lines.

- Remarks**
1. p: CSI number (p = 00), m: Unit number (m = 0), n: Channel number (n = 0)
  2.  $f_{MCK}$ : Serial array unit operation clock frequency  
(Operation clock to be set by the CKSmn bit of serial mode register mn (SMRmn). m: Unit number, n: Channel number (mn = 00))

**CSI mode connection diagram**

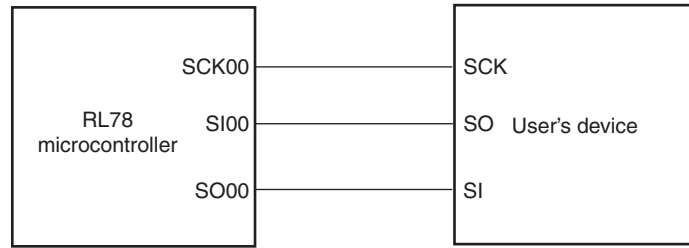

**CSI mode serial transfer timing**  
 (When DAP00 = 0 and CKP00 = 0, or DAP00 = 1 and CKP00 = 1.)

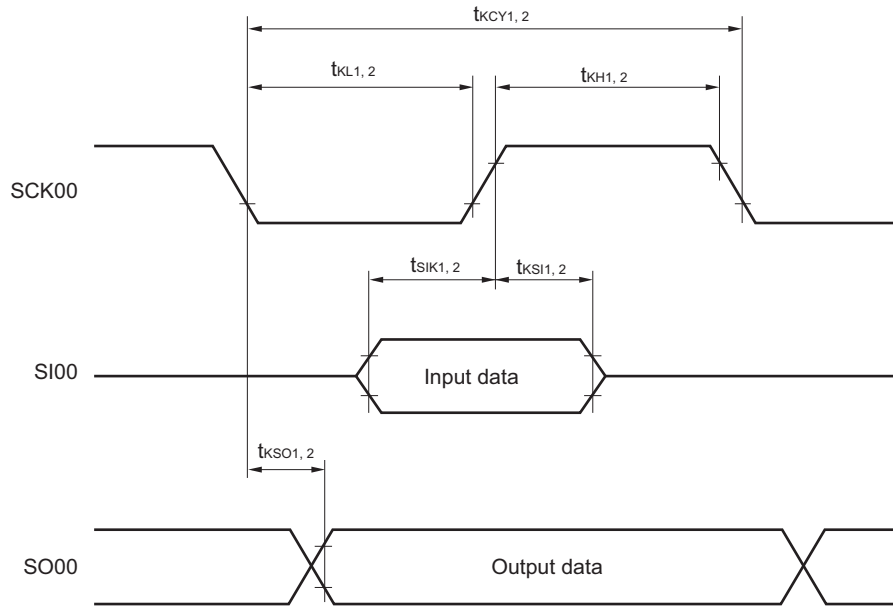

**(4) Simplified I<sup>2</sup>C mode****(T<sub>A</sub> = -40 to +85°C, 2.0 V ≤ V<sub>DD</sub> ≤ 5.5 V, V<sub>SS</sub> = 0 V)**

Parameter	Symbol	Conditions	MIN.	MAX.	Unit
SCLr clock frequency	f <sub>SCL</sub>	2.0 V ≤ V <sub>DD</sub> ≤ 5.5 V, C <sub>b</sub> = 100 pF, R <sub>b</sub> = 3 kΩ		400 <sup>Note 1</sup>	kHz
Hold time when SCLr = "L"	t <sub>LOW</sub>	2.0 V ≤ V <sub>DD</sub> ≤ 5.5 V, C <sub>b</sub> = 100 pF, R <sub>b</sub> = 3 kΩ	1150		ns
Hold time when SCLr = "H"	t <sub>HIGH</sub>	2.0 V ≤ V <sub>DD</sub> ≤ 5.5 V, C <sub>b</sub> = 100 pF, R <sub>b</sub> = 3 kΩ	1150		ns
Data setup time (reception)	t <sub>SU: DAT</sub>	2.0 V ≤ V <sub>DD</sub> ≤ 5.5 V, C <sub>b</sub> = 100 pF, R <sub>b</sub> = 3 kΩ	1/f <sub>MCK</sub> + 145 <sup>Note 2</sup>		ns
Data hold time (transmission)	t <sub>HD: DAT</sub>	2.0 V ≤ V <sub>DD</sub> ≤ 5.5 V, C <sub>b</sub> = 100 pF, R <sub>b</sub> = 3 kΩ	0	355	ns

- Notes**
- The value must also be equal to or less than f<sub>MCK</sub>/4.
  - Set the f<sub>MCK</sub> value to keep the hold time of SCLr = "L" and SCLr = "H".

**Caution** Select the N-ch open drain output (V<sub>DD</sub> tolerance) mode for the SDAr pin by using the port output mode register 0 (POM0).

- Remarks**
- R<sub>b</sub> [Ω]: Communication line (SDAr) pull-up resistance, C<sub>b</sub> [F]: Communication line (SCLr, SDAr) load capacitance
  - r: IIC number (r = 00)
  - f<sub>MCK</sub>: Serial array unit operation clock frequency  
(Operation clock to be set by the CKSmn bit of serial mode register mn (SMRmn).  
m: Unit number, n: Channel number (mn = 00))

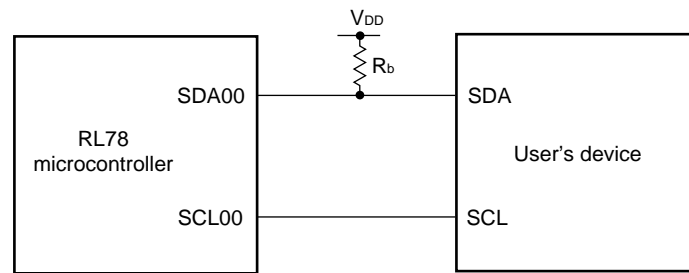
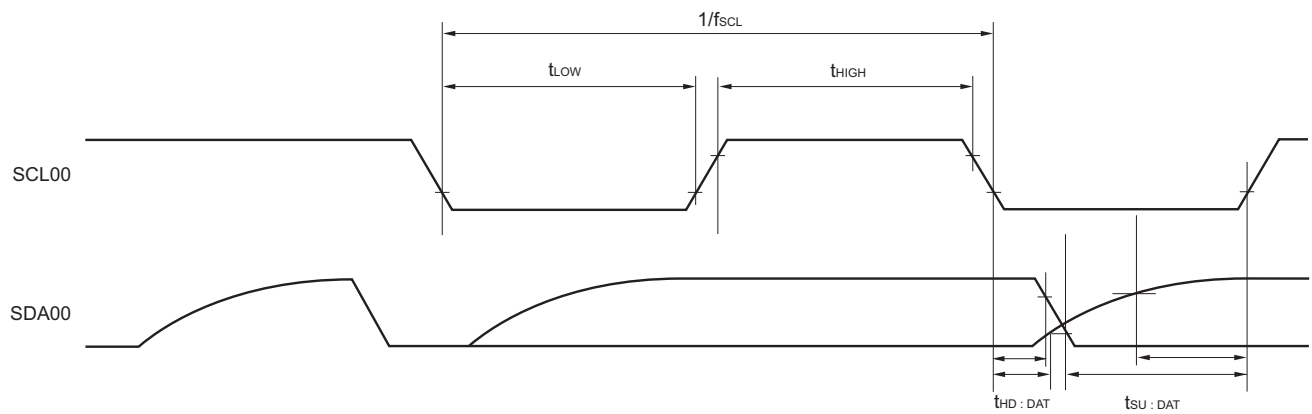
**Simplified I<sup>2</sup>C mode connection diagram****Simplified I<sup>2</sup>C mode serial transfer timing**

## 2.6 Analog Characteristics

### 2.6.1 A/D converter characteristics

(Target ANI pin : ANI0 to ANI3)

( $T_A = -40$  to  $+85^\circ\text{C}$ ,  $2.4\text{ V} \leq V_{DD} \leq 5.5\text{ V}$ ,  $V_{SS} = 0\text{ V}$ )

Parameter	Symbol	Conditions		MIN.	TYP.	MAX.	Unit
Resolution	$R_{ES}$			8		10	bit
Overall error <sup>Note 1</sup>	$A_{INL}$	10-bit resolution	$V_{DD} = 5\text{ V}$		$\pm 1.7$	$\pm 3.1$ <sup>Note 2</sup>	LSB
			$V_{DD} = 3\text{ V}$		$\pm 2.3$	$\pm 4.5$ <sup>Note 2</sup>	LSB
Conversion time	$t_{CONV}$	10-bit resolution	$2.7\text{ V} \leq V_{DD} \leq 5.5\text{ V}$	3.4		18.4	$\mu\text{s}$
			$2.4\text{ V} \leq V_{DD} \leq 5.5\text{ V}$	4.6		18.4	$\mu\text{s}$
Zero-scale error <sup>Note 1</sup>	$E_{ZS}$	10-bit resolution	$V_{DD} = 5\text{ V}$			$\pm 0.19$ <sup>Note 2</sup>	%FSR
			$V_{DD} = 3\text{ V}$			$\pm 0.39$ <sup>Note 2</sup>	%FSR
Full-scale error <sup>Note 1</sup>	$E_{FS}$	10-bit resolution	$V_{DD} = 5\text{ V}$			$\pm 0.29$ <sup>Note 2</sup>	%FSR
			$V_{DD} = 3\text{ V}$			$\pm 0.42$ <sup>Note 2</sup>	%FSR
Integral linearity error <sup>Note 1</sup>	$I_{LE}$	10-bit resolution	$V_{DD} = 5\text{ V}$			$\pm 1.8$ <sup>Note 2</sup>	LSB
			$V_{DD} = 3\text{ V}$			$\pm 1.7$ <sup>Note 2</sup>	LSB
Differential linearity error <sup>Note 1</sup>	$D_{LE}$	10-bit resolution	$V_{DD} = 5\text{ V}$			$\pm 1.4$ <sup>Note 2</sup>	LSB
			$V_{DD} = 3\text{ V}$			$\pm 1.5$ <sup>Note 2</sup>	LSB
Analog input voltage	$V_{AIN}$			0		$V_{DD}$	V

**Notes** 1. Excludes quantization error ( $\pm 1/2$  LSB).

2. This is the characteristic evaluation value plus or minus 3. These values are not used in the shipping inspection.

### 2.6.2 SPOR circuit characteristics

( $T_A = -40$  to  $+85^\circ\text{C}$ ,  $V_{SS} = 0\text{ V}$ )

Parameter	Symbol	Conditions	MIN.	TYP.	MAX.	Unit
Detection supply voltage	$V_{SPOR0}$	Power supply rise time	4.08	4.28	4.45	V
		Power supply fall time	4.00	4.20	4.37	V
	$V_{SPOR1}$	Power supply rise time	2.76	2.90	3.02	V
		Power supply fall time	2.70	2.84	2.96	V
	$V_{SPOR2}$	Power supply rise time	2.44	2.57	2.68	V
		Power supply fall time	2.40	2.52	2.62	V
	$V_{SPOR3}$	Power supply rise time	2.05	2.16	2.25	V
		Power supply fall time	2.00	2.11	2.20	V
Minimum pulse width <sup>Note</sup>	$T_{SPW}$		300			$\mu\text{s}$

**Note** Time required for the reset operation by the SPOR when  $V_{DD}$  becomes under  $V_{SPDR}$ .

### 2.6.3 Power supply voltage rising slope characteristics

( $T_A = -40$  to  $+85^\circ\text{C}$ ,  $V_{SS} = 0\text{ V}$ )

Parameter	Symbol	Conditions	MIN.	TYP.	MAX.	Unit
Power supply voltage rising slope	$S_{VDD}$				54	V/ms

#### 2.6.4 Data retention power supply voltage characteristics

( $T_A = -40$  to  $+85^\circ\text{C}$ ,  $V_{SS} = 0$  V)

Parameter	Symbol	Conditions	MIN.	TYP.	MAX.	Unit
Data retention power supply voltage range	$V_{DDDR}$		1.9		5.5	V

**Caution** Data is retained until the power supply voltage becomes under the minimum value of the data retention power supply voltage range. Note that data in the RAM and RESF registers might not be cleared even if the power supply voltage becomes under the minimum value of the data retention power supply voltage range.

## 2.7 Flash Memory Programming Characteristics

( $T_A = 0$  to  $+40^\circ\text{C}$ ,  $4.5\text{ V} \leq V_{DD} \leq 5.5\text{ V}$ ,  $V_{SS} = 0\text{ V}$ )

Parameter	Symbol	Conditions		MIN.	TYP.	MAX.	Unit
Code flash memory rewritable times <sup>Notes 1, 2, 3</sup>	$C_{erwr}$	Retained for 20 years.	$T_A = +85^\circ\text{C}$	1000			Times

- Notes**
- 1 erase + 1 write after the erase is regarded as 1 rewrite. The retaining years are until next rewrite after the rewrite.
  2. When using flash memory programmer.
  3. These are the characteristics of the flash memory and the results obtained from reliability testing by Renesas Electronics Corporation.

## 2.8 Dedicated Flash Memory Programmer Communication (UART)

( $T_A = 0$  to  $+40^\circ\text{C}$ ,  $4.5\text{ V} \leq V_{DD} \leq 5.5\text{ V}$ ,  $V_{SS} = 0\text{ V}$ )

Parameter	Symbol	Conditions	MIN.	TYP.	MAX.	Unit
Transfer rate				115,200		bps

**Remark** The transfer rate during flash memory programming is fixed to 115,200 bps.

2.9 Timing of Entry to Flash Memory Programming Modes

Parameter	Symbol	Conditions	MIN.	TYP.	MAX.	Unit
How long from when an external reset ends until the initial communication settings are specified	$t_{SUIINIT}$	SPOR reset must end before the external reset ends.			100	ms
How long from when the TOOL0 pin is placed at the low level until an external reset ends	$t_{SU}$	SPOR reset must end before the external reset ends.	10			$\mu s$
How long the TOOL0 pin must be kept at the low level after an external reset ends	$t_{HD}$	SPOR reset must end before the external reset ends.	1			ms

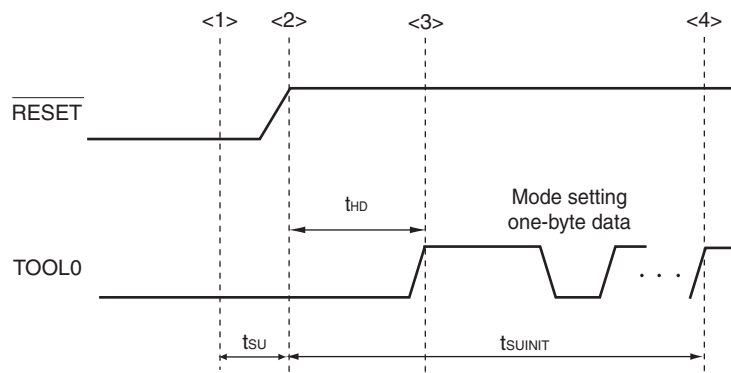

- <1> The low level is input to the TOOL0 pin.
- <2> The external reset ends (SPOR reset must end before the external reset ends.).
- <3> The TOOL0 pin is set to the high level.
- <4> Setting of entry to the flash memory programming mode by UART reception.

**Remark**  $t_{SUIINIT}$ : The segment shows that it is necessary to finish specifying the initial communication settings within 100 ms from when the resets end.

$t_{SU}$ : How long from when the TOOL0 pin is placed at the low level until an external reset ends (MIN. 10  $\mu s$ )

$t_{HD}$ : How long to keep the TOOL0 pin at the low level from when the external reset ends

### 3. PACKAGE DRAWINGS

#### 3.1 10-pin products

R5F10Y16ASP, R5F10Y14ASP

JEITA Package Code	RENESAS Code	Previous Code	MASS (TYP.) [g]
P-LSSOP10-4.4x3.6-0.65	PLSP0010JA-A	P10MA-65-CAC-2	0.05

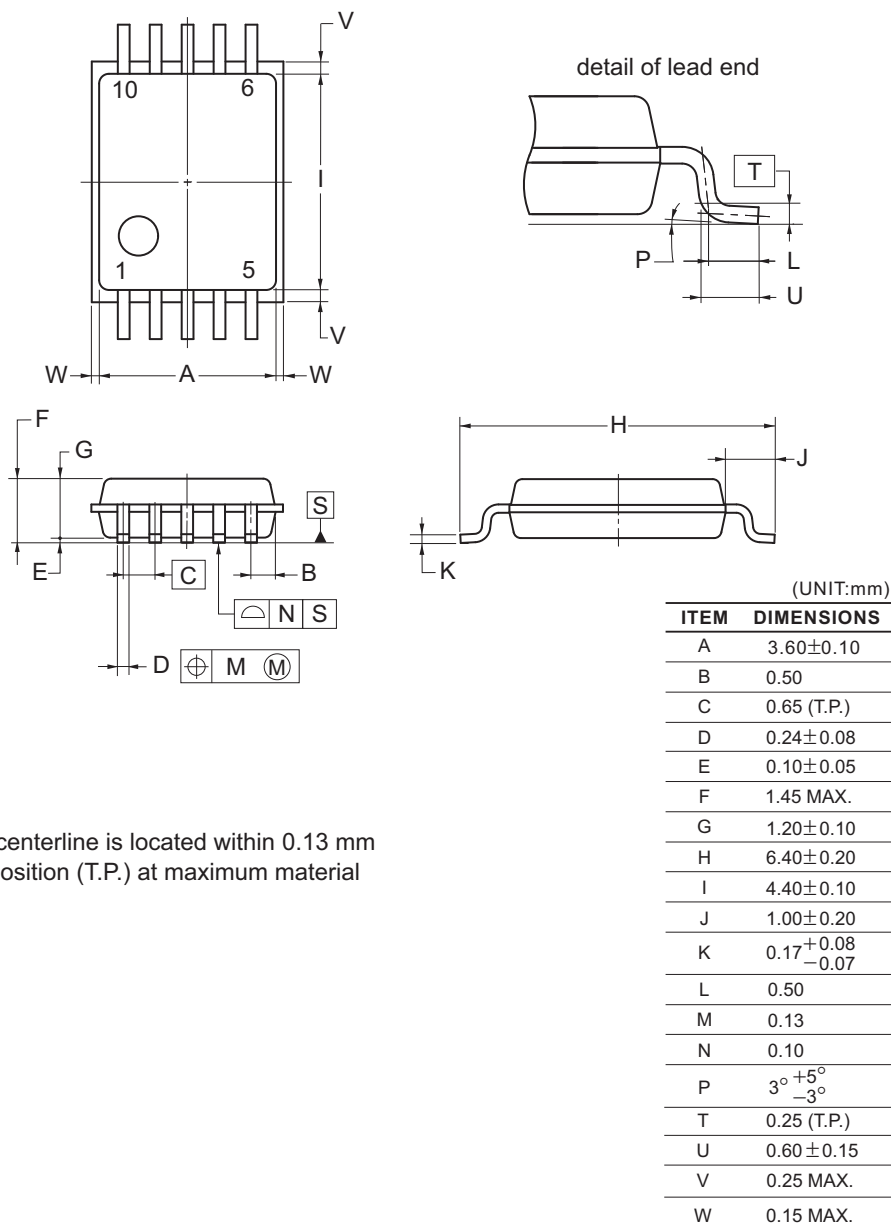

**NOTE**  
Each lead centerline is located within 0.13 mm of its true position (T.P.) at maximum material condition.

3.2 16-pin products

R5F10Y47ASP, R5F10Y46ASP, R5F10Y44ASP

JEITA Package Code	RENESAS Code	Previous Code	MASS (TYP.) [g]
P-SSOP16-4.4x5-0.65	PRSP0016JC-A	P16MA-65-FAA-2	0.08

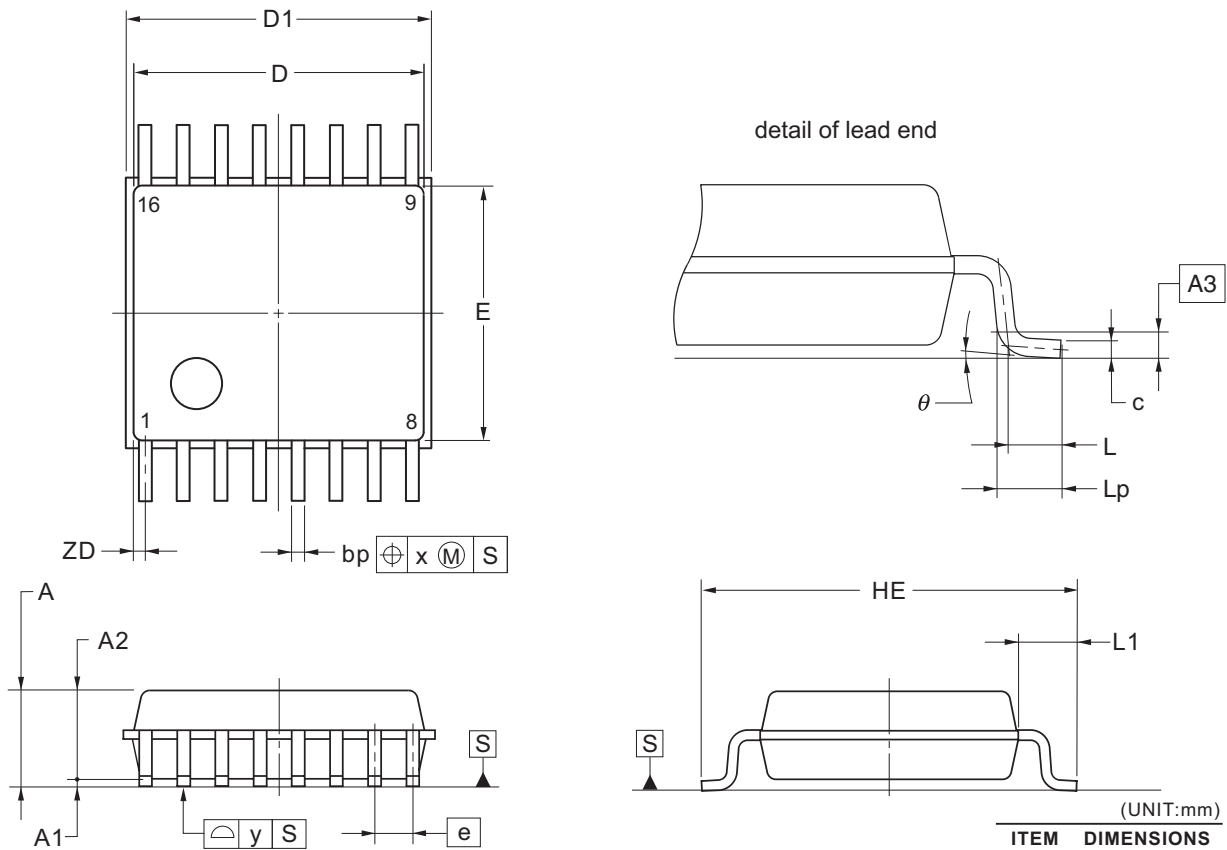

(UNIT:mm)

ITEM	DIMENSIONS
D	5.00±0.15
D1	5.20±0.15
E	4.40±0.20
HE	6.40±0.20
A	1.725 MAX.
A1	0.125±0.05
A2	1.50
A3	0.25
e	0.65
bp	0.22 <sup>+0.08</sup> <sub>-0.07</sub>
c	0.15 <sup>+0.03</sup> <sub>-0.04</sub>
L	0.50
Lp	0.60±0.10
L1	1.00±0.20
x	0.13
y	0.10
θ	3° <sup>+5°</sup> <sub>-3°</sub>
ZD	0.325

©2012 Renesas Electronics Corporation. All rights reserved.

<b>Revision History</b>	<b>RL78/G10 Data Sheet</b>
-------------------------	----------------------------

Rev.	Date	Description	
		Page	Summary
1.00	Apr 15, 2013	-	First Edition issued

All trademarks and registered trademarks are the property of their respective owners.

SuperFlash is a registered trademark of Silicon Storage Technology, Inc. in several countries including the United States and Japan.

Caution: This product uses SuperFlash® technology licensed from Silicon Storage Technology, Inc.
--

## NOTES FOR CMOS DEVICES

- (1) **VOLTAGE APPLICATION WAVEFORM AT INPUT PIN:** Waveform distortion due to input noise or a reflected wave may cause malfunction. If the input of the CMOS device stays in the area between VIL (MAX) and VIH (MIN) due to noise, etc., the device may malfunction. Take care to prevent chattering noise from entering the device when the input level is fixed, and also in the transition period when the input level passes through the area between VIL (MAX) and VIH (MIN).
- (2) **HANDLING OF UNUSED INPUT PINS:** Unconnected CMOS device inputs can be cause of malfunction. If an input pin is unconnected, it is possible that an internal input level may be generated due to noise, etc., causing malfunction. CMOS devices behave differently than Bipolar or NMOS devices. Input levels of CMOS devices must be fixed high or low by using pull-up or pull-down circuitry. Each unused pin should be connected to VDD or GND via a resistor if there is a possibility that it will be an output pin. All handling related to unused pins must be judged separately for each device and according to related specifications governing the device.
- (3) **PRECAUTION AGAINST ESD:** A strong electric field, when exposed to a MOS device, can cause destruction of the gate oxide and ultimately degrade the device operation. Steps must be taken to stop generation of static electricity as much as possible, and quickly dissipate it when it has occurred. Environmental control must be adequate. When it is dry, a humidifier should be used. It is recommended to avoid using insulators that easily build up static electricity. Semiconductor devices must be stored and transported in an anti-static container, static shielding bag or conductive material. All test and measurement tools including work benches and floors should be grounded. The operator should be grounded using a wrist strap. Semiconductor devices must not be touched with bare hands. Similar precautions need to be taken for PW boards with mounted semiconductor devices.
- (4) **STATUS BEFORE INITIALIZATION:** Power-on does not necessarily define the initial status of a MOS device. Immediately after the power source is turned ON, devices with reset functions have not yet been initialized. Hence, power-on does not guarantee output pin levels, I/O settings or contents of registers. A device is not initialized until the reset signal is received. A reset operation must be executed immediately after power-on for devices with reset functions.
- (5) **POWER ON/OFF SEQUENCE:** In the case of a device that uses different power supplies for the internal operation and external interface, as a rule, switch on the external power supply after switching on the internal power supply. When switching the power supply off, as a rule, switch off the external power supply and then the internal power supply. Use of the reverse power on/off sequences may result in the application of an overvoltage to the internal elements of the device, causing malfunction and degradation of internal elements due to the passage of an abnormal current. The correct power on/off sequence must be judged separately for each device and according to related specifications governing the device.
- (6) **INPUT OF SIGNAL DURING POWER OFF STATE :** Do not input signals or an I/O pull-up power supply while the device is not powered. The current injection that results from input of such a signal or I/O pull-up power supply may cause malfunction and the abnormal current that passes in the device at this time may cause degradation of internal elements. Input of signals during the power off state must be judged separately for each device and according to related specifications governing the device.

## Notice

1. Descriptions of circuits, software and other related information in this document are provided only to illustrate the operation of semiconductor products and application examples. You are fully responsible for the incorporation of these circuits, software, and information in the design of your equipment. Renesas Electronics assumes no responsibility for any losses incurred by you or third parties arising from the use of these circuits, software, or information.
2. Renesas Electronics has used reasonable care in preparing the information included in this document, but Renesas Electronics does not warrant that such information is error free. Renesas Electronics assumes no liability whatsoever for any damages incurred by you resulting from errors in or omissions from the information included herein.
3. Renesas Electronics does not assume any liability for infringement of patents, copyrights, or other intellectual property rights of third parties by or arising from the use of Renesas Electronics products or technical information described in this document. No license, express, implied or otherwise, is granted hereby under any patents, copyrights or other intellectual property rights of Renesas Electronics or others.
4. You should not alter, modify, copy, or otherwise misappropriate any Renesas Electronics product, whether in whole or in part. Renesas Electronics assumes no responsibility for any losses incurred by you or third parties arising from such alteration, modification, copy or otherwise misappropriation of Renesas Electronics product.
5. Renesas Electronics products are classified according to the following two quality grades: "Standard" and "High Quality". The recommended applications for each Renesas Electronics product depends on the product's quality grade, as indicated below.  
"Standard": Computers; office equipment; communications equipment; test and measurement equipment; audio and visual equipment; home electronic appliances; machine tools; personal electronic equipment; and industrial robots etc.  
"High Quality": Transportation equipment (automobiles, trains, ships, etc.); traffic control systems; anti-disaster systems; anti-crime systems; and safety equipment etc.  
Renesas Electronics products are neither intended nor authorized for use in products or systems that may pose a direct threat to human life or bodily injury (artificial life support devices or systems, surgical implantations etc.), or may cause serious property damages (nuclear reactor control systems, military equipment etc.). You must check the quality grade of each Renesas Electronics product before using it in a particular application. You may not use any Renesas Electronics product for any application for which it is not intended. Renesas Electronics shall not be in any way liable for any damages or losses incurred by you or third parties arising from the use of any Renesas Electronics product for which the product is not intended by Renesas Electronics.
6. You should use the Renesas Electronics products described in this document within the range specified by Renesas Electronics, especially with respect to the maximum rating, operating supply voltage range, movement power voltage range, heat radiation characteristics, installation and other product characteristics. Renesas Electronics shall have no liability for malfunctions or damages arising out of the use of Renesas Electronics products beyond such specified ranges.
7. Although Renesas Electronics endeavors to improve the quality and reliability of its products, semiconductor products have specific characteristics such as the occurrence of failure at a certain rate and malfunctions under certain use conditions. Further, Renesas Electronics products are not subject to radiation resistance design. Please be sure to implement safety measures to guard them against the possibility of physical injury, and injury or damage caused by fire in the event of the failure of a Renesas Electronics product, such as safety design for hardware and software including but not limited to redundancy, fire control and malfunction prevention, appropriate treatment for aging degradation or any other appropriate measures. Because the evaluation of microcomputer software alone is very difficult, please evaluate the safety of the final products or systems manufactured by you.
8. Please contact a Renesas Electronics sales office for details as to environmental matters such as the environmental compatibility of each Renesas Electronics product. Please use Renesas Electronics products in compliance with all applicable laws and regulations that regulate the inclusion or use of controlled substances, including without limitation, the EU RoHS Directive. Renesas Electronics assumes no liability for damages or losses occurring as a result of your noncompliance with applicable laws and regulations.
9. Renesas Electronics products and technology may not be used for or incorporated into any products or systems whose manufacture, use, or sale is prohibited under any applicable domestic or foreign laws or regulations. You should not use Renesas Electronics products or technology described in this document for any purpose relating to military applications or use by the military, including but not limited to the development of weapons of mass destruction. When exporting the Renesas Electronics products or technology described in this document, you should comply with the applicable export control laws and regulations and follow the procedures required by such laws and regulations.
10. It is the responsibility of the buyer or distributor of Renesas Electronics products, who distributes, disposes of, or otherwise places the product with a third party, to notify such third party in advance of the contents and conditions set forth in this document, Renesas Electronics assumes no responsibility for any losses incurred by you or third parties as a result of unauthorized use of Renesas Electronics products.
11. This document may not be reproduced or duplicated in any form, in whole or in part, without prior written consent of Renesas Electronics.
12. Please contact a Renesas Electronics sales office if you have any questions regarding the information contained in this document or Renesas Electronics products, or if you have any other inquiries.

(Note 1) "Renesas Electronics" as used in this document means Renesas Electronics Corporation and also includes its majority-owned subsidiaries.

(Note 2) "Renesas Electronics product(s)" means any product developed or manufactured by or for Renesas Electronics.



### SALES OFFICES

Renesas Electronics Corporation

<http://www.renesas.com>

Refer to "<http://www.renesas.com/>" for the latest and detailed information.

**Renesas Electronics America Inc.**  
2880 Scott Boulevard Santa Clara, CA 95050-2554, U.S.A.  
Tel: +1-408-588-6000, Fax: +1-408-588-6130

**Renesas Electronics Canada Limited**  
1101 Nicholson Road, Newmarket, Ontario L3Y 9C3, Canada  
Tel: +1-905-898-5441, Fax: +1-905-898-3220

**Renesas Electronics Europe Limited**  
Dukes Meadow, Millboard Road, Bourne End, Buckinghamshire, SL8 5FH, U.K  
Tel: +44-1628-651-700, Fax: +44-1628-651-804

**Renesas Electronics Europe GmbH**  
Arcadiastrasse 10, 40472 Düsseldorf, Germany  
Tel: +49-211-65030, Fax: +49-211-6503-1327

**Renesas Electronics (China) Co., Ltd.**  
7th Floor, Quantum Plaza, No.27 ZhiChunLu Haidian District, Beijing 100083, P.R.China  
Tel: +86-10-8235-1155, Fax: +86-10-8235-7679

**Renesas Electronics (Shanghai) Co., Ltd.**  
Unit 204, 205, AZIA Center, No.1233 Lujiazui Ring Rd., Pudong District, Shanghai 200120, China  
Tel: +86-21-5877-1818, Fax: +86-21-6887-7858 / -7898

**Renesas Electronics Hong Kong Limited**  
Unit 1601-1613, 16/F., Tower 2, Grand Century Place, 193 Prince Edward Road West, Mongkok, Kowloon, Hong Kong  
Tel: +852-2886-9318, Fax: +852 2886-9022/9044

**Renesas Electronics Taiwan Co., Ltd.**  
13F, No. 363, Fu Shing North Road, Taipei, Taiwan  
Tel: +886-2-8175-9600, Fax: +886 2-8175-9670

**Renesas Electronics Singapore Pte. Ltd.**  
80 Bendemeer Road, Unit #06-02 Hyflux Innovation Centre Singapore 339949  
Tel: +65-6213-0200, Fax: +65-6213-0300

**Renesas Electronics Malaysia Sdn.Bhd.**  
Unit 906, Block B, Menara Amcorp, Amcorp Trade Centre, No. 18, Jln Persiaran Barat, 46050 Petaling Jaya, Selangor Darul Ehsan, Malaysia  
Tel: +60-3-7955-9390, Fax: +60-3-7955-9510

**Renesas Electronics Korea Co., Ltd.**  
11F., Samik Lavied' or Bldg., 720-2 Yeoksam-Dong, Kangnam-Ku, Seoul 135-080, Korea  
Tel: +82-2-558-3737, Fax: +82-2-558-5141

## Looking for pricing, stock, or lifecycle information?

Click below to explore more details on WIN SOURCE:

- ⊖ [View R5F10Y16ASP#V0 on WIN SOURCE](#)
- ⊖ [Renesas Electronics America Information](#)

## Optimize Your Supply Chain with WIN SOURCE Solutions

- ✓ Global Sourcing Solution
- ✓ Obsolete Management
- ✓ Cost Control Management
- ✓ Shortage Management
- ✓ Alternative Solution
- ✓ Excess Inventory Management