

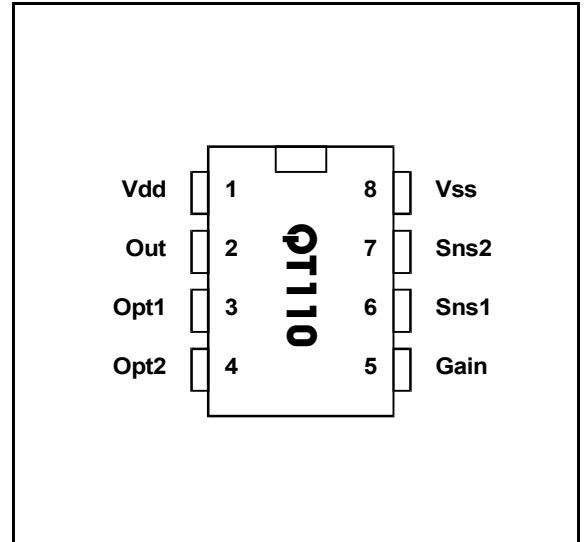


# THE DATASHEET OF QT110-IS



# QProx™ QT110 / QT110H CHARGE-TRANSFER TOUCH SENSOR

- Less expensive than many mechanical switches
- Projects a 'touch button' through any dielectric
- Turns small objects into intrinsic touch sensors
- 100% autocal for life - no adjustments required
- Only one external part required - a 1¢ capacitor
- Piezo sounder direct drive for 'tactile' click feedback
- LED drive for visual feedback
- 2.5 to 5V 20µA single supply operation
- Toggle mode for on/off control (strap option)
- 10s or 60s auto-recalibration timeout (strap option)
- Pulse output mode (strap option)
- Gain settings in 3 discrete levels
- Simple 2-wire operation possible
- HeartBeat™ health indicator on output
- Active Low (QT110), Active High (QT110H) versions



## APPLICATIONS -

- |                     |                     |                    |                    |
|---------------------|---------------------|--------------------|--------------------|
| ● Light switches    | ● Appliance control | ● Access systems   | ● Elevator buttons |
| ● Industrial panels | ● Security systems  | ● Pointing devices | ● Toys & games     |

The QT110 / QT110H charge-transfer ("QT") touch sensor is a self-contained digital IC capable of detecting near-proximity or touch. It will project a sense field through almost any dielectric, like glass, plastic, stone, ceramic, and most kinds of wood. It can also turn small metal-bearing objects into intrinsic sensors, making them respond to proximity or touch. This capability coupled with its ability to self calibrate continuously can lead to entirely new product concepts.

It is designed specifically for human interfaces, like control panels, appliances, toys, lighting controls, or anywhere a mechanical switch or button may be found; it may also be used for some material sensing and control applications provided that the presence duration of objects does not exceed the recalibration timeout interval.

The IC requires only a common inexpensive capacitor in order to function. A bare piezo beeper can be connected to create a 'tactile' feedback clicking sound; the beeper itself then doubles as the required external capacitor, and it can also become the sensing electrode. An LED can also be added to provide visual sensing indication. With a second inexpensive capacitor the device can operated in 2-wire mode, where both power and signal traverse the same wire pair to a host. This mode allows the sensor to be wired to a controller with only a twisted pair over a long distances.

Power consumption is under 20µA in most applications, allowing operation from Lithium cells for many years. In most cases the power supply need only be minimally regulated.

The IC's RISC core employs signal processing techniques pioneered by Quantum; these are specifically designed to make the device survive real-world challenges, such as 'stuck sensor' conditions and signal drift. Even sensitivity is digitally determined and remains constant in the face of large variations in sample capacitor  $C_s$  and electrode  $C_x$ . No external switches, opamps, or other analog components aside from  $C_s$  are usually required.

The device includes several user-selectable built in features. One, toggle mode, permits on/off touch control, for example for light switch replacement. Another makes the sensor output a pulse instead of a DC level, which allows the device to 'talk' over the power rail, permitting a simple 2-wire interface. The Quantum-pioneered HeartBeat™ signal is also included, allowing a host controller to monitor the health of the QT110 continuously if desired. By using the charge transfer principle, the IC delivers a level of performance clearly superior to older technologies in a highly cost-effective package.

### AVAILABLE OPTIONS

T <sub>A</sub>	SOIC	8-PIN DIP
0°C to +70°C	QT110-S	QT110-D
0°C to +70°C	QT110H-S	QT110H-D
-40°C to +85°C	QT110-IS	-
-40°C to +85°C	QT110H-IS	-

# 1 - OVERVIEW

The QT110 is a digital burst mode charge-transfer (QT) sensor designed specifically for touch controls; it includes all hardware and signal processing functions necessary to provide stable sensing under a wide variety of changing conditions. Only a single low cost, non-critical capacitor is required for operation.

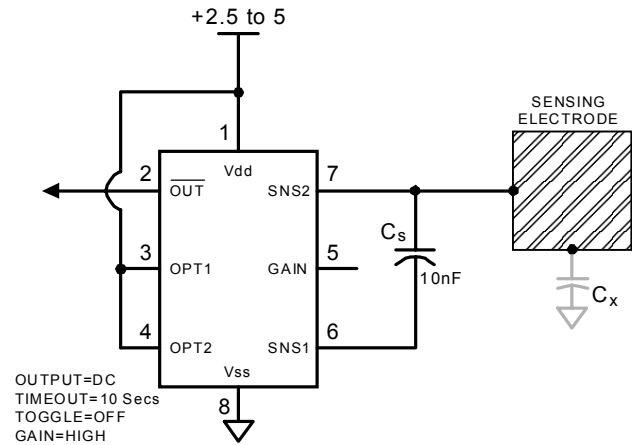
Figure 1-1 shows the basic QT110 circuit using the device, with a conventional output drive and power supply connections. Figure 1-2 shows a second configuration using a common power/signal rail which can be a long twisted pair from a controller; this configuration uses the built-in pulse mode to transmit output state to the host controller (QT110 only).

## 1.1 BASIC OPERATION

The QT110 employs short, ultra-low duty cycle bursts of charge-transfer cycles to acquire its signal. Burst mode permits power consumption in the low microamp range, dramatically reduces RF emissions, lowers susceptibility to EMI, and yet permits excellent response time. Internally the signals are digitally processed to reject impulse noise, using a 'consensus' filter which requires four consecutive confirmations of a detection before the output is activated.

The QT switches and charge measurement hardware functions are all internal to the QT110 (Figure 1-3). A 14-bit single-slope switched capacitor ADC includes both the required QT charge and transfer switches in a configuration that provides direct ADC conversion. The ADC is designed to dynamically optimize the QT burst length according to the rate of charge buildup on  $C_s$ , which in turn depends on the values of  $C_s$ ,  $C_x$ , and  $V_{dd}$ .  $V_{dd}$  is used as the charge reference voltage. Larger values of  $C_x$  cause the charge transferred into  $C_s$  to rise more rapidly, reducing available resolution; as a minimum resolution is required for proper operation, this can result in dramatically reduced apparent gain. Conversely, larger values of  $C_s$  reduce the rise of differential voltage across it, increasing available resolution by permitting longer QT bursts. The value of  $C_s$  can thus be increased to allow larger values of  $C_x$  to be tolerated (Figures 4-1, 4-2, 4-3 in Specifications, rear).

Figure 1-1 Standard mode options



The IC is highly tolerant of changes in  $C_s$  since it computes the threshold level ratiometrically with respect to absolute load, and does so dynamically at all times.

$C_s$  is thus non-critical; as it drifts with temperature, the threshold algorithm compensates for the drift automatically.

A simple circuit variation is to replace  $C_s$  with a bare piezo sounder (Section 2), which is merely another type of capacitor, albeit with a large thermal drift coefficient. If  $C_{piezo}$  is in the proper range, no other external component is required. If  $C_{piezo}$  is too small, it can simply be 'topped up' with an inexpensive ceramic capacitor connected in parallel with it. The QT110 drives a 4kHz signal across SNS1 and SNS2 to make the piezo (if installed) sound a short tone for 75ms immediately after detection, to act as an audible confirmation.

Option pins allow the selection or alteration of several special features and sensitivity.

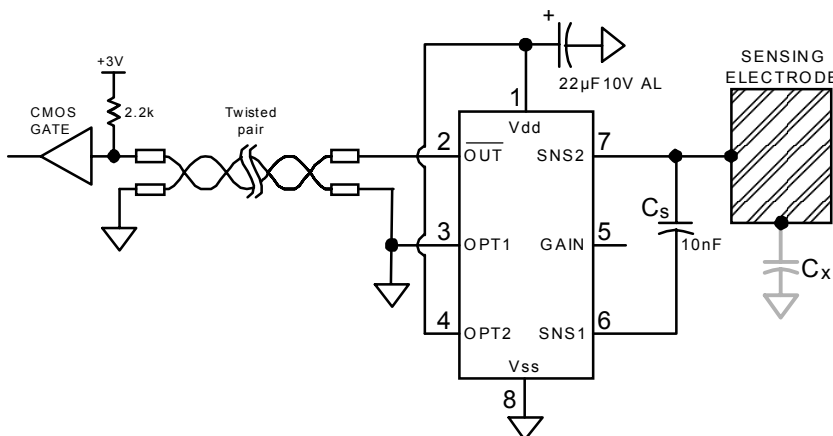
## 1.2 ELECTRODE DRIVE

The internal ADC treats  $C_s$  as a floating transfer capacitor; as a direct result, the sense electrode can be connected to either SNS1 or SNS2 with no performance difference. In both cases the rule  $C_s \gg C_x$  must be observed for proper operation. The polarity of the charge buildup across  $C_s$  during a burst is the same in either case.

It is possible to connect separate  $C_x$  and  $C_x'$  loads to SNS1 and SNS2 simultaneously, although the result is no different than if the loads were connected together at SNS1 (or SNS2). It is important to limit the amount of stray capacitance on both terminals, especially if the load  $C_x$  is already large, for example by minimizing trace lengths and widths so as not to exceed the  $C_x$  load specification and to allow for a larger sensing electrode size if so desired.

The PCB traces, wiring, and any components associated with or in contact with SNS1 and SNS2 will become touch sensitive and should be

Figure 1-2 2-wire operation, self-powered (QT110 only)



treated with caution to limit the touch area to the desired location. Multiple touch electrodes can be used, for example to create a control button on both sides of an object, however it is impossible for the sensor to distinguish between the two touch areas.

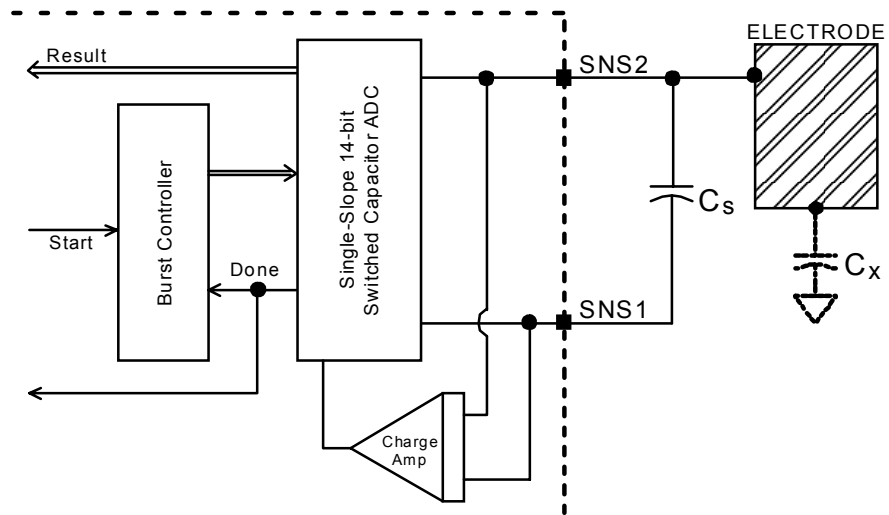
### 1.3 ELECTRODE DESIGN

#### 1.3.1 ELECTRODE GEOMETRY AND SIZE

There is no restriction on the shape of the electrode; in most cases common sense and a little experimentation can result in a good electrode design. The QT110 will operate equally well with long, thin electrodes as with round or square ones; even random shapes are acceptable. The electrode can also be a 3-dimensional surface or object. Sensitivity is related to electrode surface area, orientation with respect to the object being sensed, object composition, and the ground coupling quality of both the sensor circuit and the sensed object.

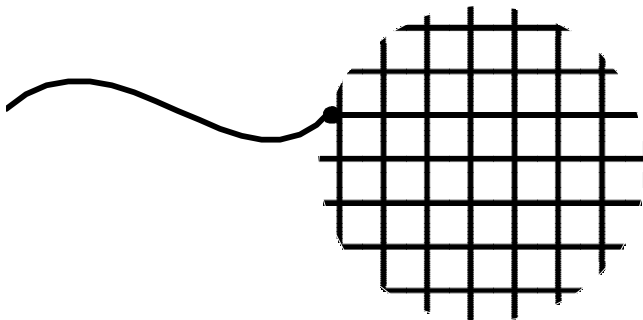
If a relatively large electrode surface is desired, and if tests

Figure 1-3 Internal Switching & Timing



will provide ample ground coupling, since there is capacitance between the windings and/or the transformer core, and from the power wiring itself directly to 'local earth'. Even when battery powered, just the physical size of the PCB and the object into which the electronics is embedded will generally be enough to couple a few picofarads back to local earth.

Figure 1-4 Mesh Electrode Geometry



show that the electrode has more capacitance than the QT110 can tolerate, the electrode can be made into a sparse mesh (Figure 1-4) having lower  $C_x$  than a solid plane. Sensitivity may even remain the same, as the sensor will be operating in a lower region of the gain curves.

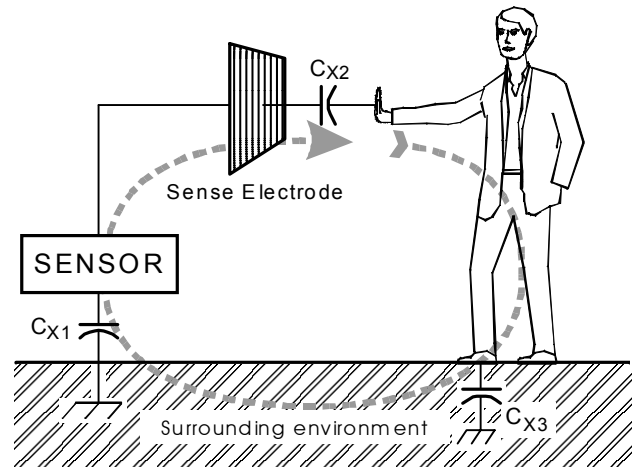
#### 1.3.2 KIRCHOFF'S CURRENT LAW

Like all capacitance sensors, the QT110 relies on Kirchoff's Current Law (Figure 1-5) to detect the change in capacitance of the electrode. This law as applied to capacitive sensing requires that the sensor's field current must complete a loop, returning back to its source in order for capacitance to be sensed. Although most designers relate to Kirchoff's law with regard to hardwired circuits, it applies equally to capacitive field flows. By implication it requires that the signal ground and the target object must both be coupled together in some manner for a capacitive sensor to operate properly. Note that there is no need to provide actual hardwired ground connections; capacitive coupling to ground ( $C_{x1}$ ) is always sufficient, even if the coupling might seem very tenuous. For example, powering the sensor via an isolated transformer

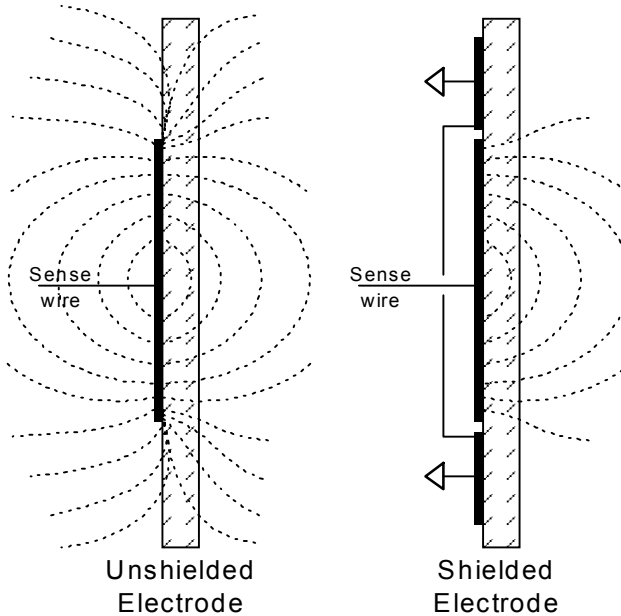
#### 1.3.3 VIRTUAL CAPACITIVE GROUNDS

When detecting human contact (e.g. a fingertip), grounding of the person is never required. The human body naturally has several hundred picofarads of 'free space' capacitance to the local environment ( $C_{x3}$  in Figure 1-5), which is more than two orders of magnitude greater than that required to create a return path to the QT110 via earth. The QT110's PCB however can be physically quite small, so there may be little 'free space' coupling ( $C_{x1}$  in Figure 1-5) between it and the environment to complete the return path. If the QT110 circuit ground cannot be earth grounded by wire, for example via the supply connections, then a 'virtual capacitive ground' may be required to increase return coupling.

Figure 1-5 Kirchoff's Current Law



**Figure 1-6 Shielding Against Fringe Fields**



A 'virtual capacitive ground' can be created by connecting the QT110's own circuit ground to:

- (1) A nearby piece of metal or metallized housing;
- (2) A floating conductive ground plane;
- (3) A nail driven into a wall when used with small electrodes;
- (4) A larger electronic device (to which its output might be connected anyway).

Free-floating ground planes such as metal foils should maximize exposed surface area in a flat plane if possible. A square of metal foil will have little effect if it is rolled up or crumpled into a ball. Virtual ground planes are more effective and can be made smaller if they are physically bonded to other surfaces, for example a wall or floor.

**1.3.4 FIELD SHAPING**

The electrode can be prevented from sensing in undesired directions with the assistance of metal shielding connected to circuit ground (Figure 1-6). For example, on flat surfaces, the field can spread laterally and create a larger touch area than desired. To stop field spreading, it is only necessary to surround the touch electrode on all sides with a ring of metal connected to circuit ground; the ring can be on the same or opposite side from the electrode. The ring will kill field spreading from that point outwards.

If one side of the panel to which the electrode is fixed has moving traffic near it, these objects can cause inadvertent detections. This is called 'walk-by' and is caused by the fact that the fields radiate from either surface of the electrode equally well. Again, shielding in the form of a metal sheet or foil connected to circuit ground will prevent walk-by; putting a small air gap between the grounded shield and the electrode will keep the value of  $C_x$  lower and is encouraged. In the case of the QT110, the sensitivity is low enough that 'walk-by' should not be a concern if the product has more than a few

millimeters of internal air gap; if the product is very thin and contact with the product's back is a concern, then some form of rear shielding may be required.

**1.3.5 SENSITIVITY**

The QT110 can be set for one of 3 gain levels using option pin 5 (Table 1-1). If left open, the gain setting is high. The sensitivity change is made by altering the numerical threshold level required for a detection. It is also a function of other things: electrode size, shape, and orientation, the thickness and composition of any overlying panel material, and the degree of ground coupling of both sensor and object are all influences.

**1.3.5.1 Increasing Sensitivity**

In some cases it may be desirable to increase sensitivity further, for example when using the sensor with very thick panels having a low dielectric constant.

Sensitivity can often be increased by using a bigger electrode, reducing panel thickness, or altering panel composition. Increasing electrode size can have diminishing returns, as high values of  $C_x$  will reduce sensor gain (Figures 4-1 ~ 4-3). Also, increasing the electrode's surface area will not substantially increase touch sensitivity if its

**Table 1-1 Gain Setting Strap Options**

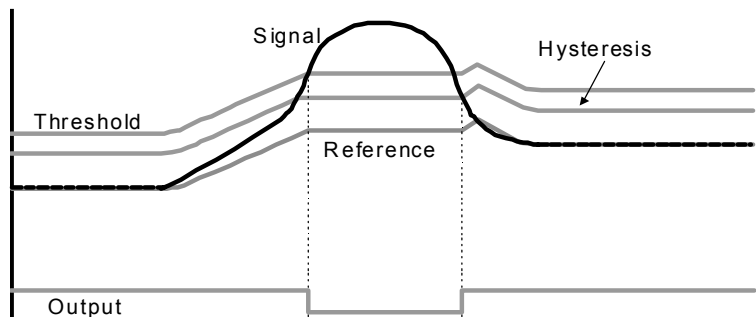
Gain	Tie Pin 5 to:
High	None
Medium	Pin 6
Low	Pin 7

diameter is already much larger in surface area than the object being detected. The panel or other intervening material can be made thinner, but again there are diminishing rewards for doing so. Panel material can also be changed to one having a higher dielectric constant, which will help propagate the field through to the front. Locally adding some conductive material to the panel (conductive materials essentially have an infinite dielectric constant) will also help dramatically; for example, adding carbon or metal fibers to a plastic panel will greatly increase frontal field strength, even if the fiber density is too low to make the plastic bulk-conductive.

**1.3.5.2 Decreasing Sensitivity**

In some cases the QT110 may be too sensitive, even on low gain. In this case gain can be lowered further by any of a

**Figure 2-1 Drift Compensation**



number of strategies: making the electrode smaller, connecting a very small capacitor in series with the sense lead, or making the electrode into a sparse mesh using a high space-to-conductor ratio (Figure 1-4). A deliberately added Cx capacitor can also be used to reduce sensitivity according to the gain curves (see Section 4).

Intermediate levels of gain (e.g. between 'medium' and 'low' can be obtained by a combination of jumper settings with one or more of the above strategies.

## 2 - QT110 SPECIFICS

### 2.1 SIGNAL PROCESSING

The QT110 processes all signals using 16 bit math, using a number of algorithms pioneered by Quantum. The algorithms are specifically designed to provide for high 'survivability' in the face of all kinds of adverse environmental changes.

#### 2.1.1 DRIFT COMPENSATION ALGORITHM

Signal drift can occur because of changes in Cx and Cs over time. It is crucial that drift be compensated for, otherwise false detections, non-detections, and sensitivity shifts will follow.

Drift compensation (Figure 2-1) is performed by making the reference level track the raw signal at a slow rate, but only while there is no detection in effect. The rate of adjustment must be performed slowly, otherwise legitimate detections could be ignored. The QT110 drift compensates using a slew-rate limited change to the reference level; the threshold and hysteresis values are slaved to this reference.

Once an object is sensed, the drift compensation mechanism ceases since the signal is legitimately high, and therefore should not cause the reference level to change.

The QT110's drift compensation is 'asymmetric': the reference level drift-compensates in one direction faster than it does in the other. Specifically, it compensates faster for decreasing signals than for increasing signals. Increasing signals should not be compensated for quickly, since an approaching finger could be compensated for partially or entirely before even touching the sense pad. However, an obstruction over the sense pad, for which the sensor has already made full allowance for, could suddenly be removed leaving the sensor with an artificially elevated reference level and thus become insensitive to touch. In this latter case, the

sensor will compensate for the object's removal very quickly, usually in only a few seconds.

#### 2.1.2 THRESHOLD CALCULATION

Sensitivity is dependent on the threshold level as well as ADC gain; threshold in turn is based on the internal signal reference level plus a small differential value. The threshold value is established as a percentage of the absolute signal level. Thus, sensitivity remains constant even if Cs is altered dramatically, so long as electrode coupling to the user remains constant. Furthermore, as Cx and Cs drift, the threshold level is automatically recomputed in real time so that it is never in error.

The QT110 employs a hysteresis dropout below the threshold level of 50% of the delta between the reference and threshold levels.

#### 2.1.3 MAX ON-DURATION

If an object or material obstructs the sense pad the signal

**Table 2-1 Output Mode Strap Options**

	Tie Pin 3 to:	Tie Pin 4 to:	Max On-Duration
DC Out	Vdd	Vdd	10s
DC Out	Vdd	Gnd	60s
Toggle	Gnd	Gnd	10s
Pulse	Gnd	Vdd	10s

may rise enough to create a detection, preventing further operation. To prevent this, the sensor includes a timer which monitors detections. If a detection exceeds the timer setting, the timer causes the sensor to perform a full recalibration. This is known as the Max On-Duration feature.

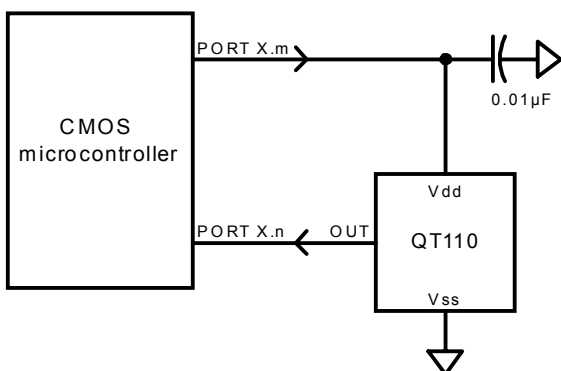
After the Max On-Duration interval, the sensor will once again function normally, even if partially or fully obstructed, to the best of its ability given electrode conditions. There are two timeout durations available via strap option: 10 and 60 seconds.

#### 2.1.4 DETECTION INTEGRATOR

It is desirable to suppress detections generated by electrical noise or from quick brushes with an object. To accomplish this, the QT110 incorporates a detect integration counter that increments with each detection until a limit is reached, after which the output is activated. If no detection is sensed prior to the final count, the counter is reset immediately to zero. In the QT110, the required count is 4.

The Detection Integrator can also be viewed as a 'consensus' filter, that requires four detections in four successive bursts to create an output. As the basic burst spacing is 75ms, if this spacing was maintained throughout all 4 counts the sensor would react very slowly. In the QT110, after an initial detection is sensed, the remaining three bursts are spaced about 18ms apart, so that the slowest reaction time possible is 75+18+18+18 or 129ms and the fastest possible is 54ms, depending on where in the initial burst interval the contact first occurred. The response time will thus average 92ms.

**Figure 2-2 Powering From a CMOS Port Pin**



### 2.1.5 FORCED SENSOR RECALIBRATION

The QT110 has no recalibration pin; a forced recalibration is accomplished only when the device is powered up. However, supply drain is so low it is a simple matter to treat the entire IC as a controllable load; simply driving the QT110's Vdd pin directly from another logic gate or a microprocessor port (Figure 2-2) will serve as both power and 'forced recal'. The source resistance of most CMOS gates and microprocessors is low enough to provide direct power without any problems. Note that most 8051-based micros have only a weak pullup drive capability and will require true CMOS buffering. Any 74HC or 74AC series gate can directly power the QT110, as can most other microprocessors.

Option strap configurations are read by the QT110 only on powerup. Configurations can only be changed by powering the QT110 down and back up again; again, a microcontroller can directly alter most of the configurations and cycle power to put them in effect.

## 2.2 OUTPUT FEATURES

The QT110 / QT110H are designed for maximum flexibility and can accommodate most popular sensing requirements. These are selectable using strap options on pins OPT1 and OPT2. All options are shown in Table 2-1.

### 2.2.1 DC MODE OUTPUT

The output of the device can respond in a DC mode, where the output is active-low (QT110) or active-high (QT110H) upon detection. The output will remain active for the duration of the detection, or until the Max On-Duration expires, whichever occurs first. If the latter occurs first, the sensor performs a full recalibration and the output becomes inactive until the next detection.

In this mode, two Max On-Duration timeouts are available: 10 and 60 seconds.

### 2.2.2 TOGGLE MODE OUTPUT

This makes the sensor respond in an on/off mode like a flip flop. It is most useful for controlling power loads, for example in kitchen appliances, power tools, light switches, etc.

Max On-Duration in Toggle mode is fixed at 10 seconds. When a timeout occurs, the sensor recalibrates but leaves the output state unchanged.

### 2.2.3 PULSE MODE OUTPUT

This generates a pulse of 75ms duration (QT110 - negative-going; QT110H - positive-going) with every new detection. It is most useful for 2-wire operation, but can also be used when bussing together several devices onto a common output line with the help of steering diodes or logic gates, in order to control a common load from several places.

Max On-Duration is fixed at 10 seconds if in Pulse output mode.

### 2.2.4 HEARTBEAT™ OUTPUT

The output has a full-time HeartBeat™ 'health' indicator superimposed on it. This operates by taking 'Out' into a 3-state mode for 350µs once before every QT burst. This output state can be used to determine that the sensor is operating properly, or, it can be ignored using one of several simple methods.

QT110: The HeartBeat indicator can be sampled by using a pulldown resistor on Out, and feeding the resulting negative-going pulse into a counter, flip flop, one-shot, or other circuit. Since Out is normally high, a pulldown resistor will create negative HeartBeat pulses (Figure 2-3) when the sensor is not detecting an object; when detecting an object, the output will remain active for the duration of the detection, and no HeartBeat pulse will be evident.

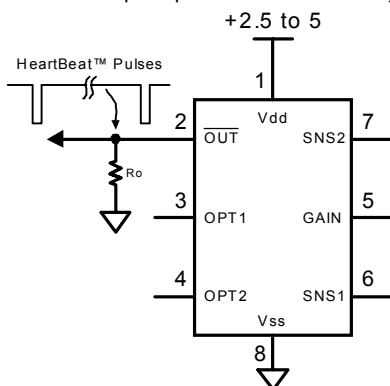
QT110H: Same as QT110 but inverted logic (use a pull-down resistor instead of a pull-up etc.)

If the sensor is wired to a microprocessor as shown in Figure 2-4, the microprocessor can reconfigure the load resistor to either ground or Vcc depending on the output state of the device, so that the pulses are evident in either state.

Electromechanical devices will usually ignore this short pulse. The pulse also has too low a duty cycle to visibly activate LED's. It can be filtered completely if desired, by adding an RC timeconstant to filter the output, or if interfacing directly and only to a high-impedance CMOS input, by doing nothing or at most adding a small non-critical capacitor from Out to ground (Figure 2-5).

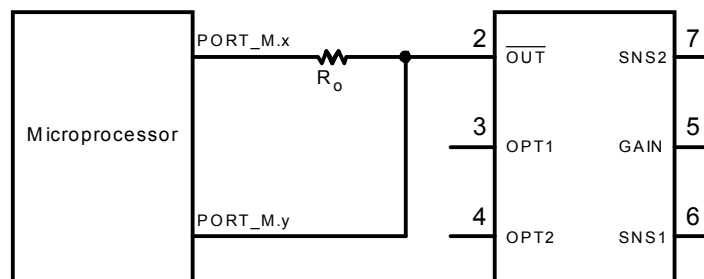
**Figure 2-3**

Getting HB pulses with a pull-down resistor (QT110 shown; use pull-up resistor with QT110H)

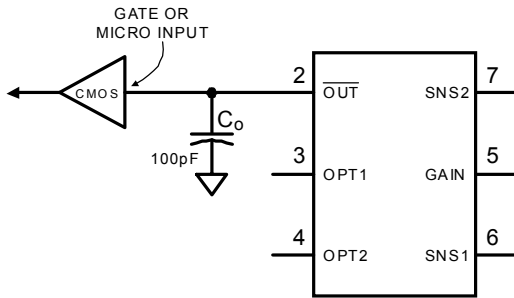


**Figure 2-4**

Using a micro to obtain HB pulses in either output state (QT110 or QT110H)



**Figure 2-5 Eliminating HB Pulses**



### 2.2.5 PIEZO ACOUSTIC DRIVE

A piezo drive signal is generated for use with a bare piezo sounder immediately after a detection is made; the tone lasts for a nominal 75ms to create a reassuring 'tactile feedback' sound.

The sensor will drive most common bare piezo 'beepers' directly using an H-bridge drive configuration for the highest possible sound level at all supply voltages; H-bridge drive effectively doubles the supply voltage across the piezo. The piezo is connected across pins SNS1 and SNS2. This drive operates at a nominal 4kHz frequency, a common resonance point for enclosed piezo sounders. Other frequencies can be obtained upon special request.

If desired a bare piezo sounder can be directly adhered to the rear of a control panel, provided that an acoustically resonant cavity is also incorporated to give the desired sound level.

Since piezo sounders are merely high-K ceramic capacitors, the sounder will double as the Cs capacitor, and the piezo's metal disc will act as the sensing electrode. Piezo transducer capacitances typically range from 6nF to 30nF (0.006µF to 0.03µF) in value; at the lower end of this range an additional capacitor should be added to bring the total Cs across SNS1 and SNS2 to at least 10nF, or more if Cx is large.

The burst acquisition process induces a small but audible voltage step across the piezo resonator, which occurs when SNS1 and SNS2 rapidly discharge residual voltage stored on the resonator. The resulting slight clicking sound can be used to provide an audible confirmation of functionality if desired, or, it can be suppressed by placing a non-critical 1M to 2M ohm bleed resistor in parallel with the resonator. The resistor acts to slowly discharge the resonator, preempting the occurrence of the harmonic-rich step (Figure 2-6).

With the resistor in place, an almost inaudible clicking sound may still be heard, which is caused by the small charge buildup across the piezo device during each burst.

### 2.2.6 OUTPUT DRIVE

The QT110's output is active low (QT110) or active high (QT110H) and can source 1mA or sink 5mA of non-inductive current. If an inductive load is used, such as a small relay, the load should be diode clamped to prevent damage.

Care should be taken when the IC and the load are both powered from the same supply, and the supply is minimally regulated. The device derives its internal references from the power supply, and sensitivity shifts can occur with changes

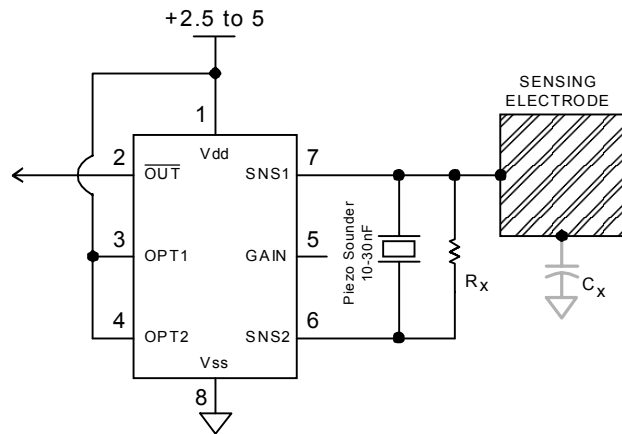
in Vdd, as happens when loads are switched on. This can induce detection 'cycling', whereby an object is detected, the load is turned on, the supply sags, the detection is no longer sensed, the load is turned off, the supply rises and the object is reacquired, *ad infinitum*. To prevent this occurrence, the output should only be lightly loaded if the device is operated from an unregulated supply, e.g. batteries. Detection 'stiction', the opposite effect, can occur if a load is *shed* when Out is active.

QT110: The output of the QT110 can directly drive a resistively limited LED. The LED should be connected with its cathode to the output and its anode towards Vcc, so that it lights when the sensor is active-low. If desired the LED can be connected from Out to ground, and driven on when the sensor is inactive, but only with less drive current (1mA).

QT110H: This part is active-high, so it works in reverse to that described above.

## 3 - CIRCUIT GUIDELINES

**Figure 2-6 Damping Piezo Clicks with Rx**



### 3.1 SAMPLE CAPACITOR

Charge sampler Cs can be virtually any plastic film or high-K ceramic capacitor. Since the acceptable Cs range is anywhere from 10nF to 30nF, the tolerance of Cs can be the lowest grade obtainable so long as its value is guaranteed to remain in the acceptable range under expected temperature conditions. Only if very fast, radical temperature swings are expected will a higher quality capacitor be required, for example polycarbonate, PPS film, or NPO/C0G ceramic.

### 3.2 PIEZO SOUNDER

The use of a piezo sounder in place of Cs is described in the previous section. Piezo sounders have very high, uncharacterized thermal coefficients and should not be used if fast temperature swings are anticipated.

### 3.3 OPTION STRAPPING

The option pins Opt1 and Opt2 should never be left floating. If they are floated, the device will draw excess power and the options will not be properly read on powerup. Intentionally,

there are no pullup resistors on these lines, since pullup resistors add to power drain if tied low.

The Gain input is designed to be floated for sensing one of the three gain settings. It should never be connected to a pullup resistor or tied to anything other than Sns1 or Sns2.

Table 2-1 shows the option strap configurations available.

### 3.4 POWER SUPPLY, PCB LAYOUT

The power supply can range from 2.5 to 5.0 volts. At 3 volts current drain averages less than 20µA in most cases, but can be higher if Cs is large. Interestingly, large Cx values will actually *decrease* power drain. Operation can be from batteries, but be cautious about loads causing supply droop (see *Output Drive*, previous section).

As battery voltage sags with use or fluctuates slowly with temperature, the IC will track and compensate for these changes automatically with only minor changes in sensitivity.

If the power supply is shared with another electronic system, care should be taken to assure that the supply is free of digital spikes, sags, and surges which can adversely affect the device. The IC will track slow changes in Vdd, but it can be affected by rapid voltage steps.

if desired, the supply can be regulated using a conventional low current regulator, for example CMOS regulators that have nanoamp quiescent currents. Care should be taken that the regulator does not have a minimum load specification, which almost certainly will be violated by the QT110's low current requirement.

Since the IC operates in a burst mode, almost all the power is consumed during the course of each burst. During the time between bursts the sensor is quiescent.

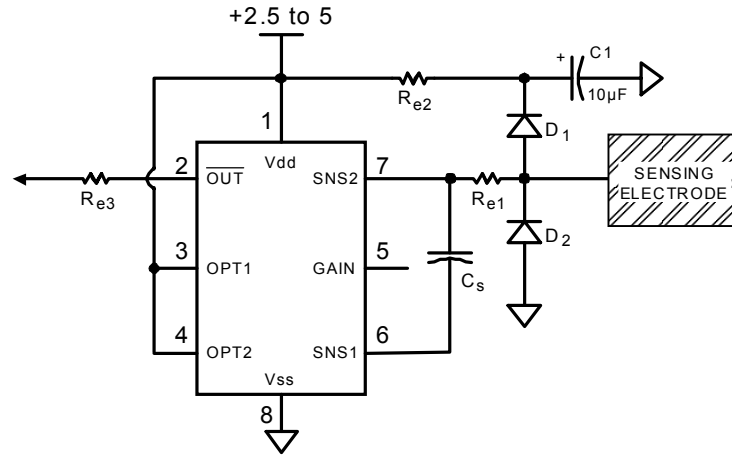
For proper operation a 100nF (0.1µF) ceramic bypass capacitor should be used between Vdd and Vss; the bypass cap should be placed very close to the device's power pins.

#### 3.4.1 MEASURING SUPPLY CURRENT

Measuring average power consumption is a fairly difficult task, due to the burst nature of the device's operation. Even a good quality RMS DMM will have difficulty tracking the relatively slow burst rate.

The simplest method for measuring average current is to replace the power supply with a large value low-leakage electrolytic capacitor, for example 2,700µF. 'Soak' the capacitor by connecting it to a bench supply at the desired operating voltage for 24 hours to form the electrolyte and reduce leakage to a minimum. Connect the capacitor to the circuit at T=0, making sure there will be no detections during the measurement interval; at T=30 seconds measure the capacitor's voltage with a DMM. Repeat the test without a load to measure the capacitor's internal leakage, and subtract the internal leakage result from the voltage droop measured during the QT110 load test. Be sure the DMM is connected only at the end of each test, to prevent the DMM's impedance from contributing to the capacitor's discharge.

Figure 2-7 ESD Protection



Supply drain can be calculated from the adjusted voltage droop using the basic charge equation:

$$i = \frac{\Delta VC}{t}$$

where C is the large supply cap value, t is the elapsed measurement time in seconds, and ΔV is the adjusted voltage droop on C.

#### 3.4.2 ESD PROTECTION

In cases where the electrode is placed behind a dielectric panel, the IC will be protected from direct static discharge. However, even with a panel, transients can still flow into the electrode via induction, or in extreme cases, via dielectric breakdown. Porous materials may allow a spark to tunnel right through the material; partially conducting materials like 'pink poly' will conduct the ESD right to the electrode. Testing is required to reveal any problems. The device does have diode protection on its terminals which can absorb and protect the device from most induced discharges, up to 20mA; the usefulness of the internal clamping will depend on the dielectric properties, panel thickness, and rise time of the ESD transients.

ESD dissipation can be aided further with an added diode protection network as shown in Figure 2-7, in extreme cases. Because the charge and transfer times of the QT110 are relatively long, the circuit can tolerate very large values of Re, more than 100k ohms in most cases where electrode Cx is small. The added diodes shown (1N4150, BAV99 or equivalent low-C diodes) will shunt the ESD transients away from the part, and Re1 will current limit the rest into the QT110's own internal clamp diodes. C1 should be around 10µF if it is to absorb positive transients from a human body model standpoint without rising in value by more than 1 volt. If desired C1 can be replaced with an appropriate zener diode. **Directly placing semiconductor transient protection devices or MOV's on the sense lead is not advised; these devices have extremely large amounts of parasitic C which will swamp the capacitance of the electrode.**

Re1 should be as large as possible given the load value of Cx and the diode capacitances of D1 and D2. Re1 should be low enough to permit at least 6 timeconstants of RC to occur during the charge and transfer phases.

Re2 functions to isolate the transient from the Vdd pin; values of around 1K ohms are reasonable.

As with all ESD protection networks, it is crucial that the transients be led away from the circuit. PCB ground layout is crucial; the ground connections to D1, D2, and C1 should all go back to the power supply ground or preferably, if available, a chassis ground connected to earth. The currents should not be allowed to traverse the area directly under the IC.

If the device is connected to an external circuit via a cable or long twisted pair, it is possible for ground-bounce to cause damage to the Out pin; even though the transients are led away from the IC itself, the connected signal or power ground line will act as an inductor, causing a high differential voltage to build up on the Out wire with respect to ground. If this is a possibility, the Out pin should have a resistance Re3 in series with it to limit current; this resistor should be as large as can be tolerated by the load.

## 4.1 ABSOLUTE MAXIMUM SPECIFICATIONS

Operating temp	..... as designated by suffix
Storage temp	..... -55°C to +125°C
V <sub>DD</sub>	..... -0.5 to +6.5V
Max continuous pin current, any control or drive pin	..... ±20mA
Short circuit duration to ground, any pin	..... infinite
Short circuit duration to V <sub>DD</sub> , any pin	..... infinite
Voltage forced onto any pin	..... -0.6V to (V <sub>DD</sub> + 0.6) Volts

## 4.2 RECOMMENDED OPERATING CONDITIONS

V <sub>DD</sub>	..... +2.5 to 5.5V
Supply ripple+noise	..... 20mV p-p max
Load capacitance	..... 0 to 20pF
Cs value	..... 10nF to 30nF

## 4.3 AC SPECIFICATIONS V<sub>DD</sub> = 3.0, T<sub>a</sub> = recommended operating range

Parameter	Description	Min	Typ	Max	Units	Notes
T <sub>RC</sub>	Recalibration time		550		ms	
T <sub>PC</sub>	Charge duration		2		µs	
T <sub>PT</sub>	Transfer duration		2		µs	
T <sub>BS</sub>	Burst spacing interval		75		ms	
T <sub>BL</sub>	Burst length	0.5		7	ms	
T <sub>R</sub>	Response time		129		ms	
F <sub>P</sub>	Piezo drive frequency		4		kHz	
T <sub>P</sub>	Piezo drive duration		75		ms	
T <sub>PO</sub>	Pulse output width on Out		75		ms	
T <sub>HB</sub>	Heartbeat pulse width		300		µs	

## 4.4 SIGNAL PROCESSING

Description	Min	Typ	Max	Units	Notes
Threshold differential, high gain		3.1		%	Note 1
Threshold differential, medium gain		4.7		%	Note 1
Threshold differential, low gain		6.25		%	Note 1
Hysteresis		50		%	Note 2
Consensus filter length		4		samples	
Positive drift compensation rate		750		ms/level	
Negative drift compensation rate		75		ms/level	
Post-detection recalibration timer duration	10		60	secs	Note 3

**Note 1:** Of absolute full scale signal

**Note 2:** Of signal threshold

**Note 3:** Strap option.

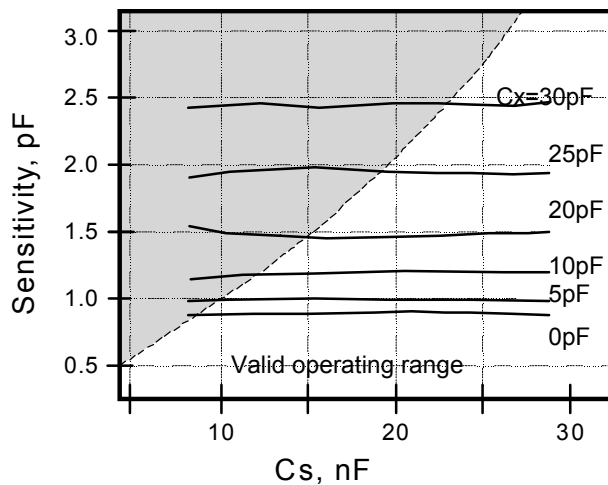
## 4.5 DC SPECIFICATIONS

V<sub>DD</sub> = 3.0V, C<sub>s</sub> = 10nF, C<sub>x</sub> = 5pF, T<sub>A</sub> = recommended range, unless otherwise noted

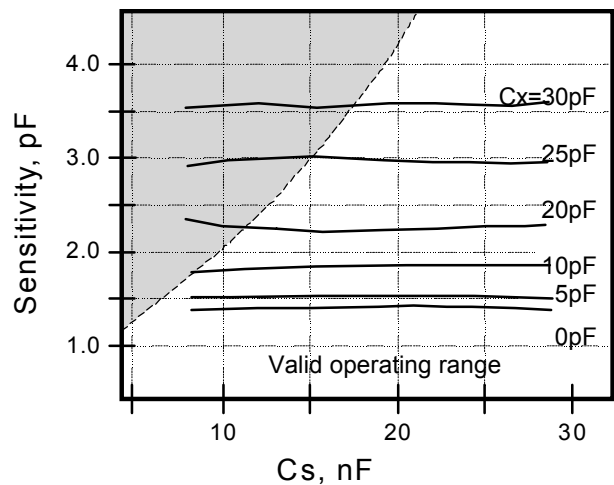
Parameter	Description	Min	Typ	Max	Units	Notes
V <sub>DD</sub>	Supply voltage	2.45		5.25	V	
I <sub>DD</sub>	Supply current		20		μA	
V <sub>DDS</sub>	Supply turn-on slope	100			V/s	Required for proper startup
V <sub>IL</sub>	Low input logic level			0.8	V	OPT1, OPT2
V <sub>HL</sub>	High input logic level	2.2			V	OPT1, OPT2
V <sub>OL</sub>	Low output voltage			0.6	V	OUT, 4mA sink
V <sub>OH</sub>	High output voltage	V <sub>DD</sub> -0.7			V	OUT, 1mA source
I <sub>IL</sub>	Input leakage current			±1	μA	OPT1, OPT2
C <sub>X</sub>	Load capacitance range	0		30	pF	
I <sub>X</sub>	Min shunt resistance		500K		Ω	Resistance from SNS1 to SNS2
A <sub>R</sub>	Acquisition resolution			14	bits	
S[1]	Sensitivity - high gain		1		pF	Refer to Figures 4-1 through 4-3
S[2]	Sensitivity - medium gain		1.5		pF	Refer to Figures 4-1 through 4-3
S[3]	Sensitivity - low gain		3		pF	Refer to Figures 4-1 through 4-3

Preliminary Data: All specifications subject to change.

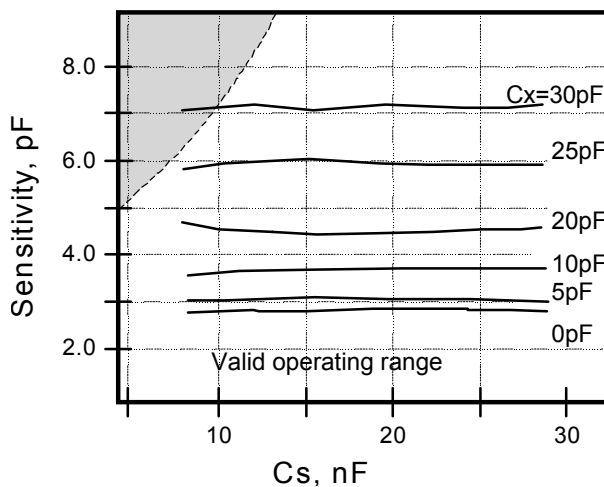
**Figure 4-1 High Gain Sensitivity and Range @ V<sub>DD</sub> = 3V**



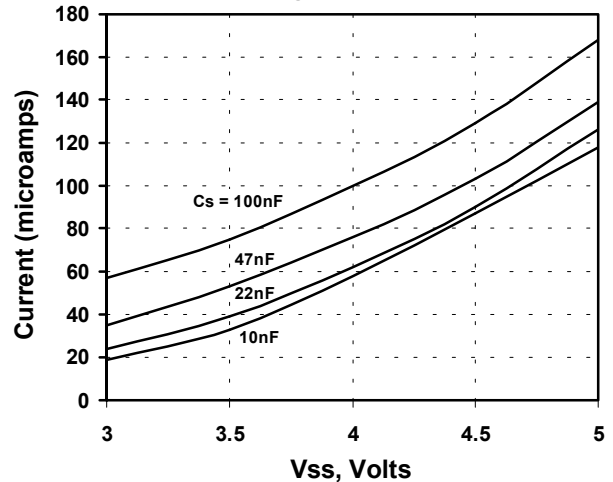
**Figure 4-2 Medium Gain Sensitivity and Range @ V<sub>DD</sub> = 3V**

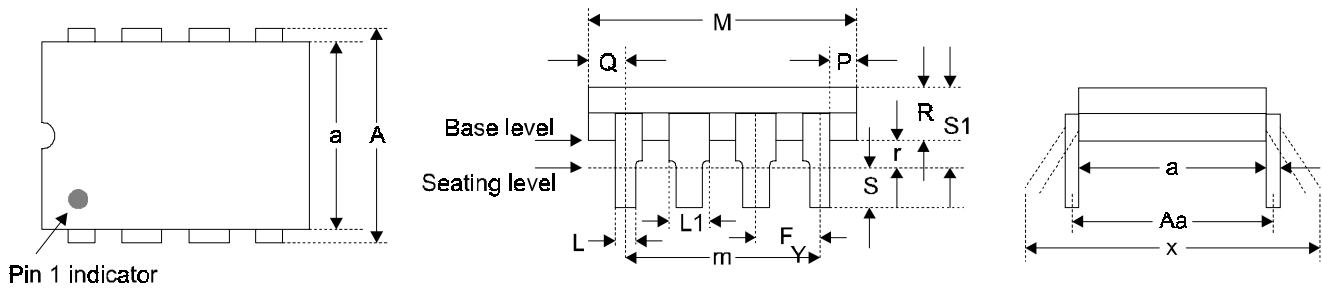


**Figure 4-3 Low Gain Sensitivity and Range @ V<sub>DD</sub> = 3V**



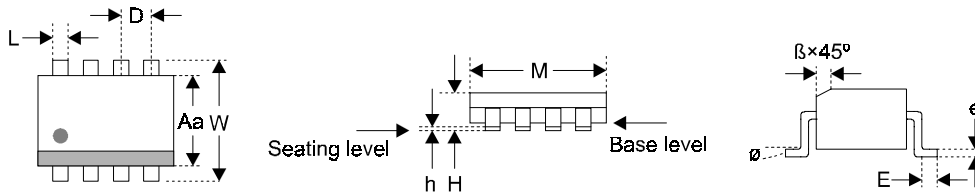
**Figure 4-4 Supply Current vs. Voltage; C<sub>x</sub> = 10pF**





**Package type: 8pin Dual-In-Line**

SYMBOL	Millimeters			Inches		
	Min	Max	Notes	Min	Max	Notes
a	6.096	7.112		0.24	0.28	
A	7.62	8.255		0.3	0.325	
M	9.017	10.922	Typical	0.355	0.43	Typical
m	7.62	7.62	BSC	0.3	0.3	BSC
Q	0.889	-		0.035	-	
P	0.254	-		0.01	-	
L	0.355	0.559		0.014	0.022	
L1	1.397	1.651		0.055	0.065	
F	2.489	2.591	Typical	0.098	0.102	Typical
R	3.048	3.81		0.12	0.15	
r	0.381	-		0.015	-	
S	3.048	3.556		0.12	0.14	
S1	-	4.064		-	0.16	
Aa	7.62	7.062	BSC	0.3	0.3	BSC
x	8.128	9.906		0.32	0.39	
Y	0.203	0.381		0.008	0.015	



**Package type: 8pin SOIC**

SYMBOL	Millimeters			Inches		
	Min	Max	Notes	Min	Max	Notes
M	4.800	4.979		0.189	0.196	
W	5.816	6.198		0.229	0.244	
Aa	3.81	3.988		0.15	0.157	
H	1.371	1.728		0.054	0.068	
h	0.101	0.762		0.004	0.01	
D	1.27	1.27	BSC	0.050	0.05	BSC
L	0.355	0.483		0.014	0.019	
E	0.508	1.016		0.02	0.04	
e	0.19	0.249		0.007	0.01	
β	0.381	0.762		0.229	0.03	
∅	0°	8°		0°	8°	

## 5 - ORDERING INFORMATION

PART	TEMP RANGE	PACKAGE	MARKING
QT110-D	0 - 70C	PDIP	QT1 + 10
QT110-S	0 - 70C	SOIC-8	QT1
QT110-IS	-40 - 85C	SOIC-8	QT1 + I
QT110H-D	0 - 70C	PDIP	QT1 +10H
QT110H-S	0 - 70C	SOIC-8	QT1 + A
QT110H-IS	-40 - 85C	SOIC-8	QT1 + AI

**Quantum Research Group Ltd**

©1999 QRG Ltd.  
Patented and patents pending

651 Holiday Drive Bldg. 5 / 300  
Pittsburgh, PA 15220 USA  
Tel: 412-391-7367 Fax: 412-291-1015  
[admin@qprox.com](mailto:admin@qprox.com)  
<http://www.qprox.com>

In the United Kingdom  
Enterprise House, Southampton, Hants SO14 3XB  
Tel: +44 (0)23 8045 3934 Fax: +44 (0)23 8045 3939

*Notice: This device expressly not for use in any medical or human safety related application without the express written consent of an officer of the company.*

## Looking for pricing, stock, or lifecycle information?

Click below to explore more details on WIN SOURCE:

- [⊖ View QT110-IS on WIN SOURCE](#)
- [⊖ Microchip Technology Information](#)

## Optimize Your Supply Chain with WIN SOURCE Solutions

- ✓ Global Sourcing Solution
- ✓ Obsolete Management
- ✓ Cost Control Management
- ✓ Shortage Management
- ✓ Alternative Solution
- ✓ Excess Inventory Management