



**THE DATASHEET OF  
PT8A977BWE**



## Features

- PT8A977B works as encoder and PT8A978B/978BL works as decoder
- Five pins for five control functions
- Operating power-supply voltage: 2.5V to 5.0V (978B), 2.0V to 5.0V (978BL), 1.8V to 5.0V(977B)
- Auto-power-off and oscillation-off if no press on any button (977B)
- Press on any button to wake up (977B)
- One output pin used for external power control (977B)
- On-chip oscillator with an external resistor
- On-chip reversing amplifiers (978B, 978BL)
- Low operating current
- Few external components needed
- Package: 14-pin DIP, 14-pin SOIC, 16-pin DIP, 16-pin SOIC, die form and wafer form

## Ordering Information

Part No.	Package
PT8A977BPE	Lead free 14-pin DIP
PT8A977BWE	Lead free and Green 14-pin SOIC
PT8A977BDE	Die Form
PT8A977BUWF	Wafer Form
PT8A978BPE	Lead free 16-pin DIP
PT8A978BLWE	Lead free and Green 16-pin SOIC
PT8A978BDE	Die Form
PT8A978BUWF	Wafer Form

**Note:**

Adding E= Pb-free or Pb-free and Green

Adding X suffix=Tape/Reel

## Description

The PT8A977B and PT8A978B (or 978BL) provide complete control functions to the remote-controlled toy. The PT8A977B has five input pins corresponding with the five function buttons i.e, forward, backward, rightward, leftward and turbo. The encoding circuit in the PT8A977B sends digital codes to the two output pins SO and SC. The digital codes correspond to the definite function buttons or their combinations. The SO and SC outputs are used in wireless and infra-red applications respectively.

The PT8A978B (or 978BL) has five output pins corresponding with the five actions. The received signals are amplified by the three-stage amplifier, and then the appropriate amplified signals are sampled, fault-tolerantly checked and decoded to control the actions of the remote-controlled toy.

There is an internal oscillator in the PT8A977B and 978B/978BL respectively. By adding an external resistor conveniently, the oscillator will be constructed. The oscillator frequency can be adjusted by the external resistor. The relative error between the frequencies of the two on-chip oscillators in the PT8A977B and PT8A978B/978BL must be less than  $\pm 25\%$ .

The auto-power-off function is achieved by an internal counter (977B). The PC output is used to control on/off state of the external power supply. Press on any function button will wake up the chip promptly.

## Block Diagram

Block Diagram of 977B

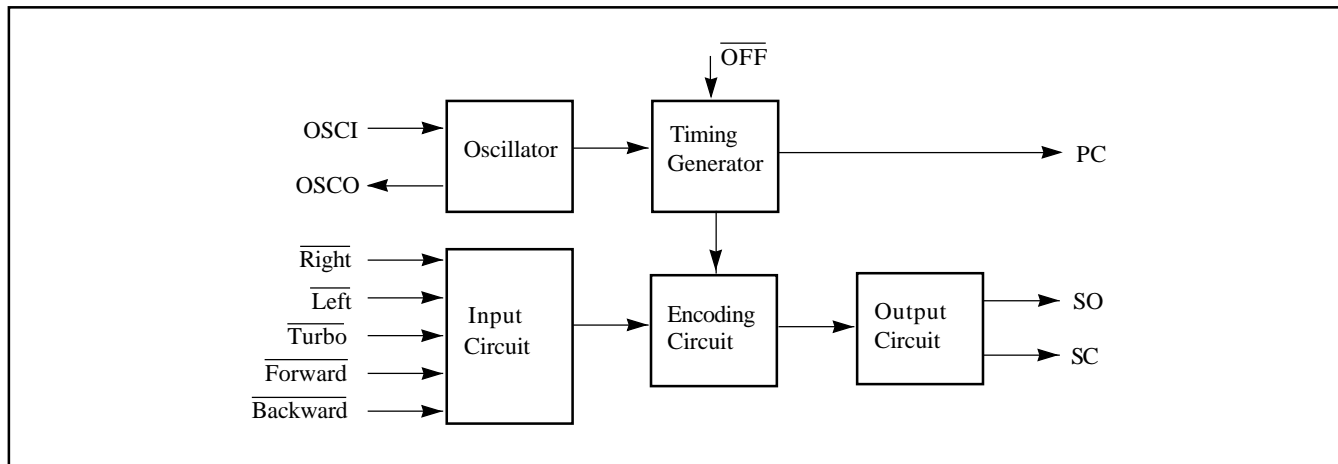

Block Diagram of 978B/978BL

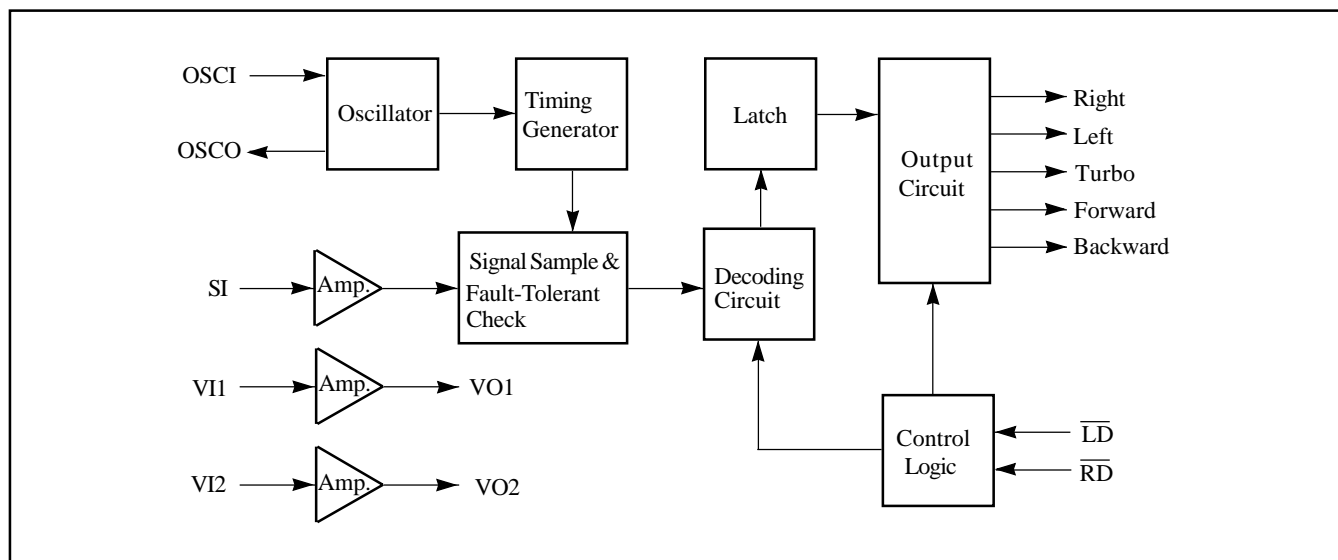

## Pin Configuration

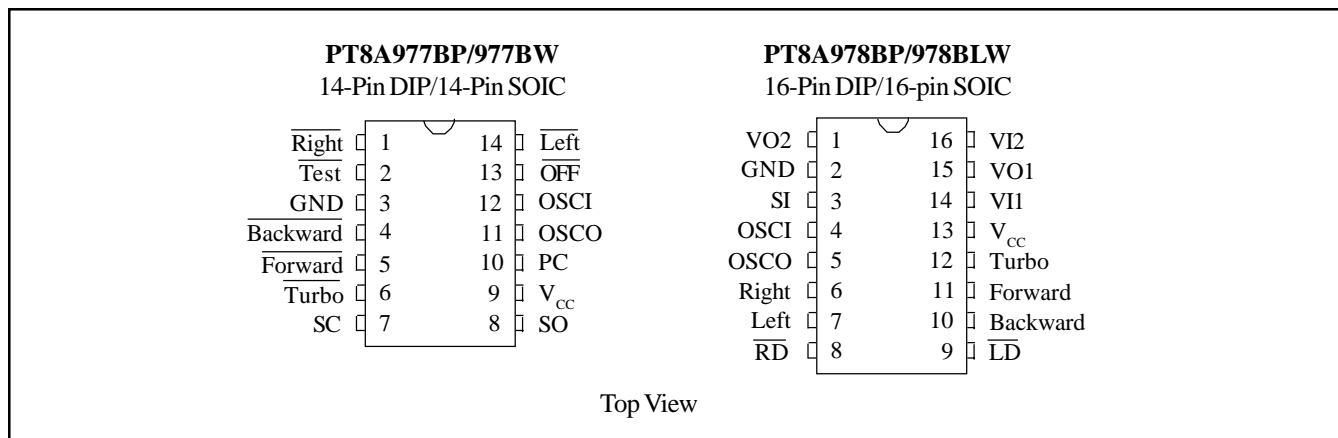

### Pad Location

PT8A977BDE

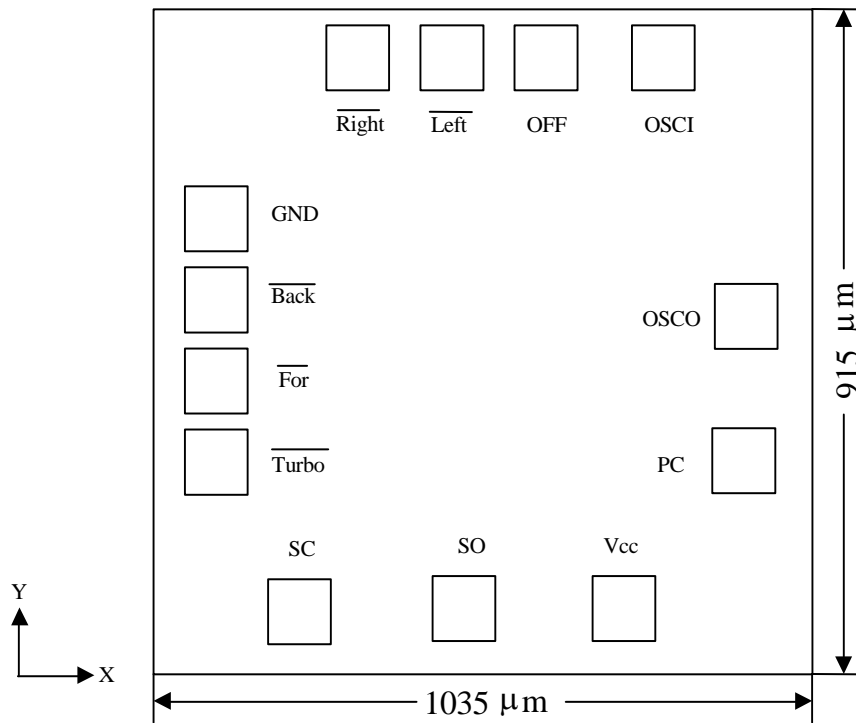

Pad Coordinates					
Pad Name	X Coordinate	Y Coordinate	Pad Name	X Coordinate	Y Coordinate
Right	292.50	754.50	Vcc	721.00	78.50
GND	50.00	597.50	PC	852.50	240.00
Backward	50.00	466.50	OSCO	852.50	428.50
Forward	50.00	361.50	OSCI	634.50	754.50
Turbo	50.00	201.50	OFF	492.50	754.50
SC	243.00	73.00	Left	392.50	754.50
SO	479.00	73.00			

Note: Substrate is connected to Vcc.

Die size is 1035μm\*915μm included scribe line( 100um\*100um). Pad size is 80.0μm\*75.0μm.

### Pad Location

PT8A978BDE

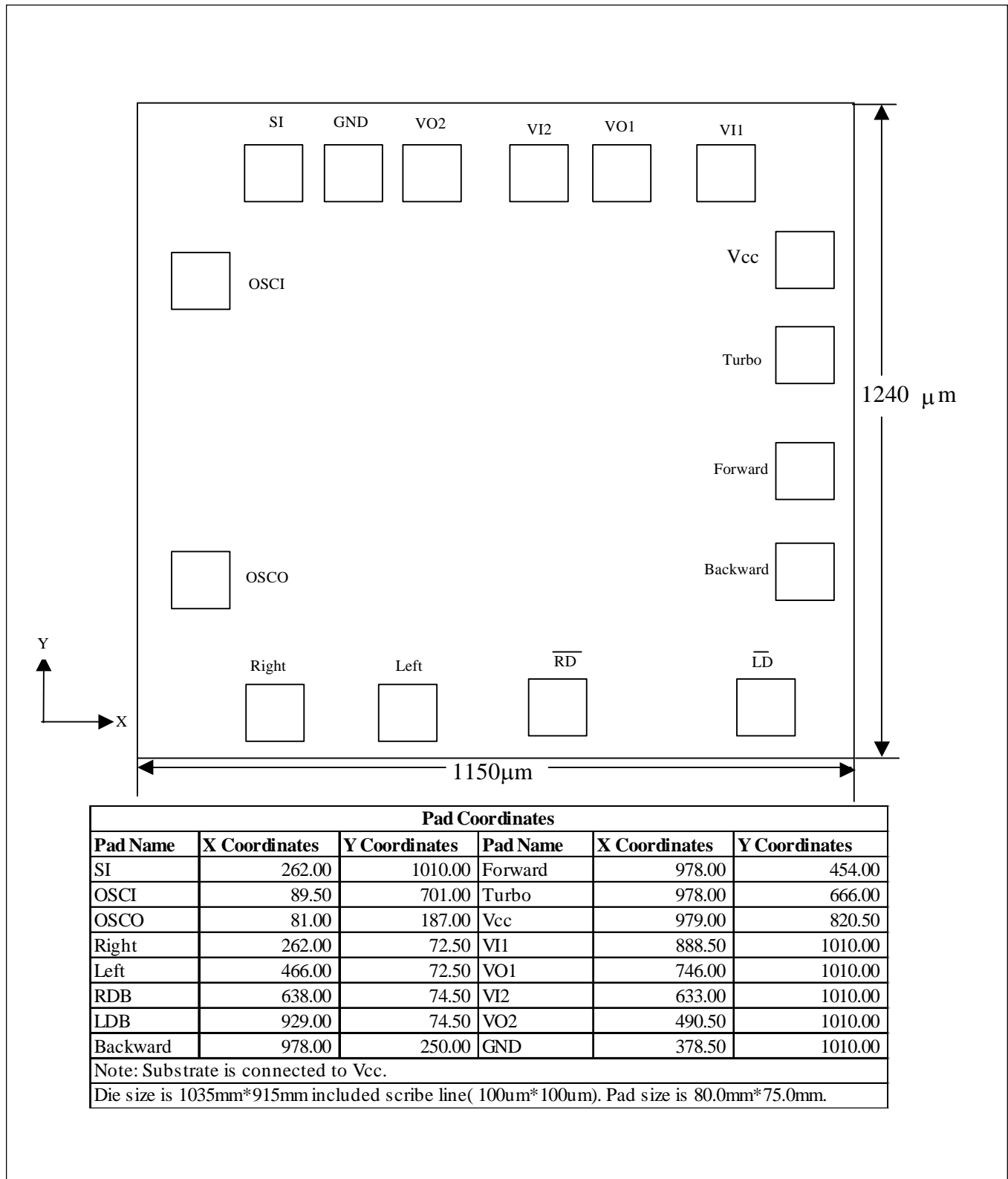

## Pin/Pad Description

### Pin/Pad Description of 977B

Pin No.	Pin/Pad Name	Description
1	Right	With Pull-up resistor, rightward function selected if this pin connected to GND.
2	GND	Negative power supply
3	Backward	With Pull-up resistor, backward function selected if this pin connected to GND.
4	Forward	With Pull-up resistor, forward function selected if this pin connected to GND.
5	Turbo	With Pull-up resistor, turbo function selected if this pin connected to GND.
6	SC	Output pin of the encoding signal with carrier frequency
7	SO	Output pin of the encoding signal without carrier frequency
8	V <sub>cc</sub>	Positive power supply
9	PC	Power control output pin
10	OSCO	Oscillator output pin
11	OSCI	Oscillator input pin
12	OFF	With Pull-up resistor, this pin is used to shut down the external power supply.
13	Left	With Pull-up resistor, leftward function selected if this pin connected to GND.

### Pin/Pad Description of 978B/978BL

Pin No.	Pin/Pad Name	Description
1	VO2	Output pin for the amplifier 2
2	GND	Negative power supply
3	SI	Input pin of the encoding signal
4	OSCI	Oscillator input pin
5	OSCO	Oscillator output pin
6	Right	Rightward output pin
7	Left	Leftward output pin
8	RD	With Pull-up resistor, rightward function disabled if this pin connected to GND.
9	LD	With Pull-up resistor, leftward function disabled if this pin connected to GND.
10	Backward	Backward output pin
11	Forward	Forward output pin
12	Turbo	Turbo output pin
13	V <sub>cc</sub>	Positive power supply
14	VI1	Input pin for the amplifier 1
15	VO1	Output pin for the amplifier 1
16	VI2	Input pin for the amplifier 2

## Maximum Ratings

(Above which the useful life may be impaired. For user guidelines, not tested)

Storage Temperature .....	-25°C to +85°C
Ambient Temperature with Power Applied .....	-10°C to +40°C
Supply Voltage to Ground Potential (Inputs & V <sub>CC</sub> Only) .....	-0.5 to +6.0V
Supply Voltage to Ground Potential (Outputs & D/O Only) ...	-0.5 to +6.0V
DC Input Voltage .....	-0.5 to +6.0V
DC Output Current .....	20mA
Power Dissipation .....	500mW

### Note:

Stresses greater than those listed under MAXIMUM RATINGS may cause permanent damage to the device. This is a stress rating only and functional operation of the device at these or any other conditions above those indicated in the operational sections of this specification is not implied. Exposure to absolute maximum rating conditions for extended periods may affect reliability.

## DC Electrical Characteristics

### DC Electrical Characteristics of 977B

Parameters	Description	Test Condition	Min.	Type	Max.	Units
V <sub>CC</sub>	Operating Voltage		1.8	4.0	5.0	V
I <sub>CC</sub>	Supply Current	Output unloaded			100	µA
I <sub>STB</sub>	Stand-by Current	OFF State			5	µA
V <sub>IL</sub>	Input Low Voltage	Guaranteed Logic LOW level			0.8	V
V <sub>IH</sub>	Input High Voltage	Guaranteed Logic HIGH level	3.0			V
I <sub>IL</sub>	Input Low Current	Pin 1, 3, 4, 5, 13 V <sub>IL</sub> = 0V, ON state			-60	µA
I <sub>IH</sub>	Input High Current	Pin 1, 3, 4, 5, 13 V <sub>IH</sub> = 4V, ON state			10	µA
I <sub>I</sub>	Input Current	Pin 11 V <sub>IH</sub> = 0 ~ 4V, ON state			± 10	µA
I <sub>OL</sub>	Output Low Current	V <sub>OUT</sub> = 0.5 V	150			µA
I <sub>OH</sub>	Output High Current	Pin 6, 7, 9 V <sub>OUT</sub> = 3.5 V	-1.0			mA
		Pin 10 V <sub>OUT</sub> = 3.5 V	-500			µA

Note: Over the Operating Rating, 0°C ≤ T<sub>A</sub> ≤ 70°C, V<sub>CC</sub> = 4V

### DC Electrical Characteristics of 978B/978BL

Parameters	Description	Test Condition	Min.	Type	Max.	Units
V <sub>CC</sub>	Operating Voltage - 978B		2.5	4.0	5.0	V
	Operating Voltage - 978BL		2.0		5.0	V
I <sub>CC</sub>	Supply Current	Output unloaded			1	mA
I <sub>STB</sub>	Stand-by Current	OFF State			10	µA
V <sub>IL</sub>	Input Low Voltage	Guaranteed Logic LOW level			0.8	V
V <sub>IH</sub>	Input High Voltage	Guaranteed Logic HIGH level	3.0			V
I <sub>IL</sub>	Input Low Current	Pin 3, 8, 9 V <sub>IL</sub> = 0V, ON state			-60	µA
I <sub>IH</sub>	Input High Current	Pin 3 V <sub>IH</sub> = 4V, ON state			60	µA
	Input High Current	Pin 8, 9 V <sub>IH</sub> = 4V, ON state			10	µA
I <sub>I</sub>	Input Current	Pin 14, 16 V <sub>IH</sub> = 0 ~ 4V, ON state			± 10	µA
I <sub>OL</sub>	Output Low Current	Pin 1, 15 V <sub>OUT</sub> = 0.5 V	200			µA
		Pin 5 V <sub>OUT</sub> = 0.5 V	500			µA
		Pin 6, 7, 10, 11, 12 V <sub>OUT</sub> = 0.5 V	1			mA
I <sub>OH</sub>	Output High Current	Pin 1, 15 V <sub>OUT</sub> = 3.5 V	-200			µA
		Pin 5 V <sub>OUT</sub> = 3.5 V	-500			µA
		Pin 6, 7, 10, 11, 12 V <sub>OUT</sub> = 2.5 V	-600			µA

Note: Over the Operating Rating, 0°C ≤ T<sub>A</sub> ≤ 70°C, V<sub>CC</sub> = 4V

## AC Electrical Characteristics

### AC Electrical Characteristics of 977B

Parameters	Description	Test Condition	Min.	Type	Max.	Units
fosc	Oscillator Frequency *	T <sub>A</sub> = 25°C, R = 200 kΩ	102	128	154	kHz
f <sub>max</sub> - f <sub>min</sub>	Oscillator Frequency Fluctuation	T <sub>A</sub> =25°C, V <sub>CC</sub> = 1.8 ~ 5V			15	kHz
tFUN	Cycle Time of Function Code	fosc = 102 to 154 kHz	0.8	1	1.2	ms
tSTA	Cycle Time of Start Code	fosc = 102 to 154 kHz	1.6	2	2.4	ms
fcsc	Carrier Frequency of SC Pin	fosc = 102 to 154 kHz	51	64	77	kHz

**Note:** Over the Operating Rating, 0°C ≤ T<sub>A</sub> ≤ 70°C, V<sub>CC</sub> = 4V

\* The relative error between the frequencies of the two on-chip oscillators in the PT8A977B and PT8A978B (or 978BL) must be less than ±25%.

### AC Electrical Characteristics of 978B/978BL

Parameters	Description	Test Condition	Min.	Type	Max.	Units
fosc	Oscillator Frequency *	T <sub>A</sub> = 25°C, R = 200 kΩ	102	128	154	kHz
f <sub>max</sub> - f <sub>min</sub>	Oscillator Frequency Fluctuation - 978B	T <sub>A</sub> =25°C, V <sub>CC</sub> =2.5 ~ 5V			15	kHz
	Oscillator Frequency Fluctuation - 978BL	T <sub>A</sub> =25°C, V <sub>CC</sub> =2.0 ~ 5V			10	kHz
VSI	SI Pin Receive Sensitivity (V <sub>PP</sub> )	Guaranteed Effective Decoding	300			mV
tFUN	Cycle Time of Function Code	fosc = 128 kHz	0.75	1	1.25	ms
tSTA	Cycle Time of Start Code	fosc = 128 kHz	1.5	2	2.5	ms

**Note:** Over the Operating Rating, 0°C ≤ T<sub>A</sub> ≤ 70°C, V<sub>CC</sub> = 4V

\* The relative error between the frequencies of the two on-chip oscillators in the PT8A977B and PT8A978B (or 978BL) must be less than ±25%.



Typical Application of PT8A978B/978BL For Transmit Circuit

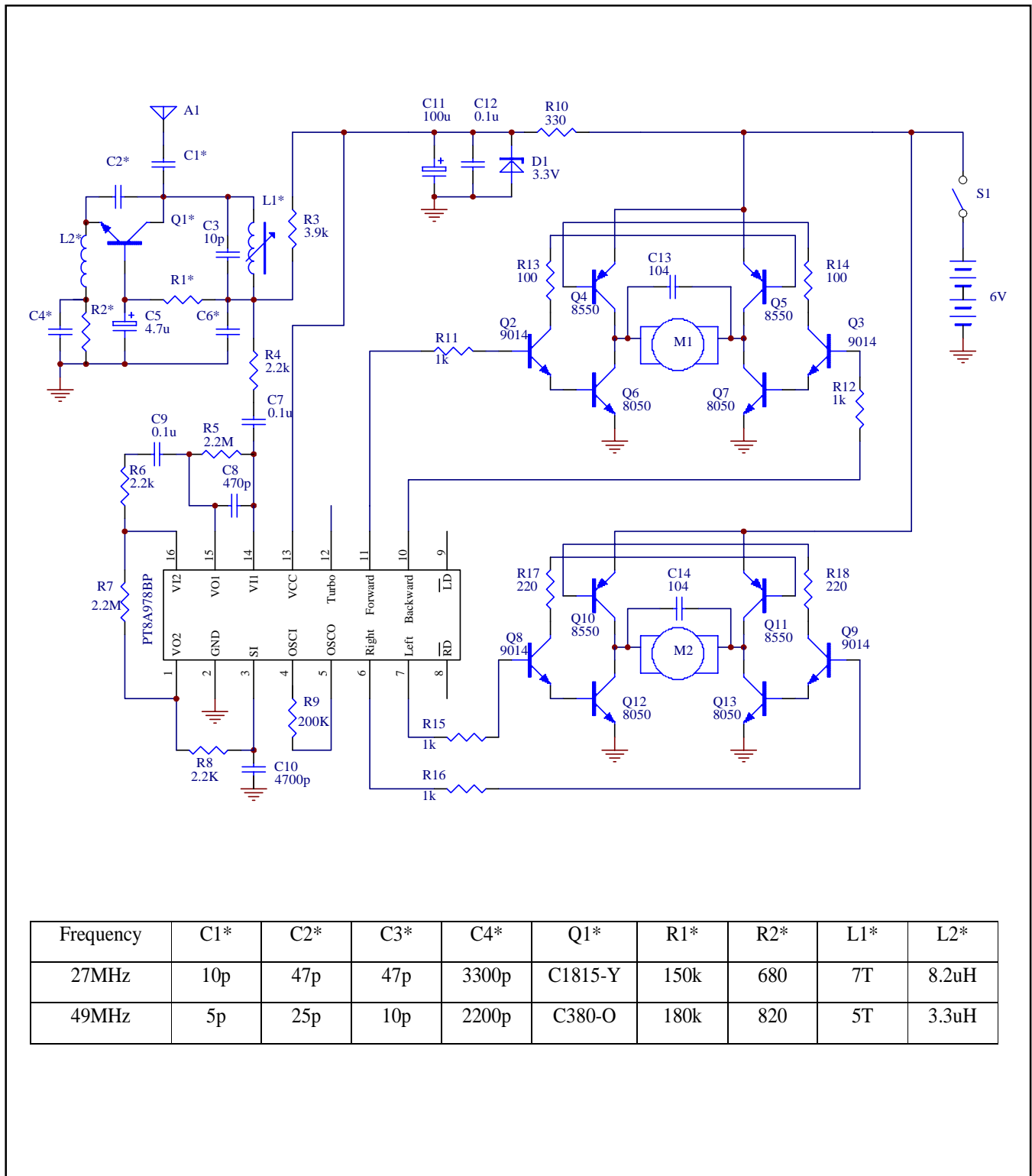

**Mechanical Information**

14-pin SOIC

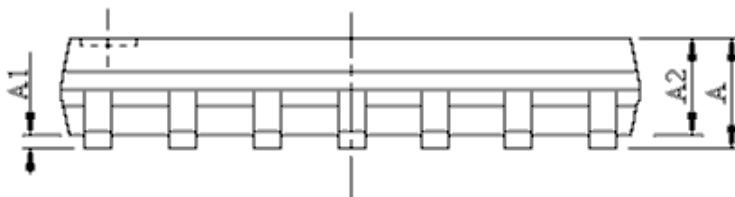
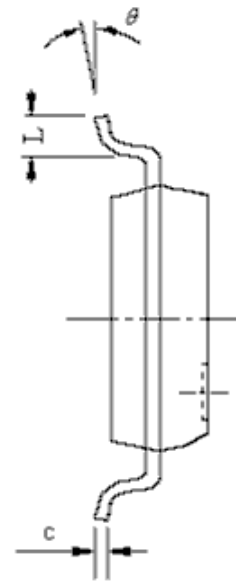
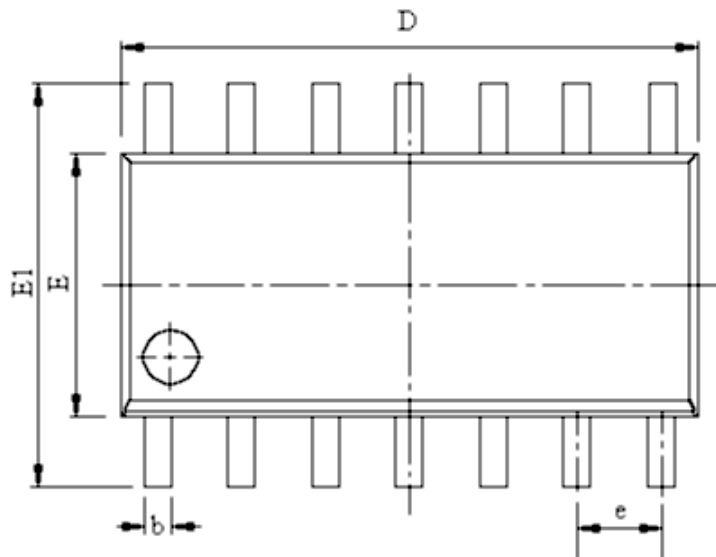

Note:  
 1) Controlling dimensions in millimeters.  
 2) Ref: JEDEC MS-012E/AB

PKG. DIMENSIONS(MM)		
SYMBOL	MIN	MAX
A	1.35	1.80
A1	0.08	0.28
A2	1.20	1.60
b	0.33	0.51
c	0.19	0.26
D	8.45	8.85
E	3.70	4.10
E1	5.80	6.30
e	1.27 TYP	
L	0.40	1.27
θ	0°	8°

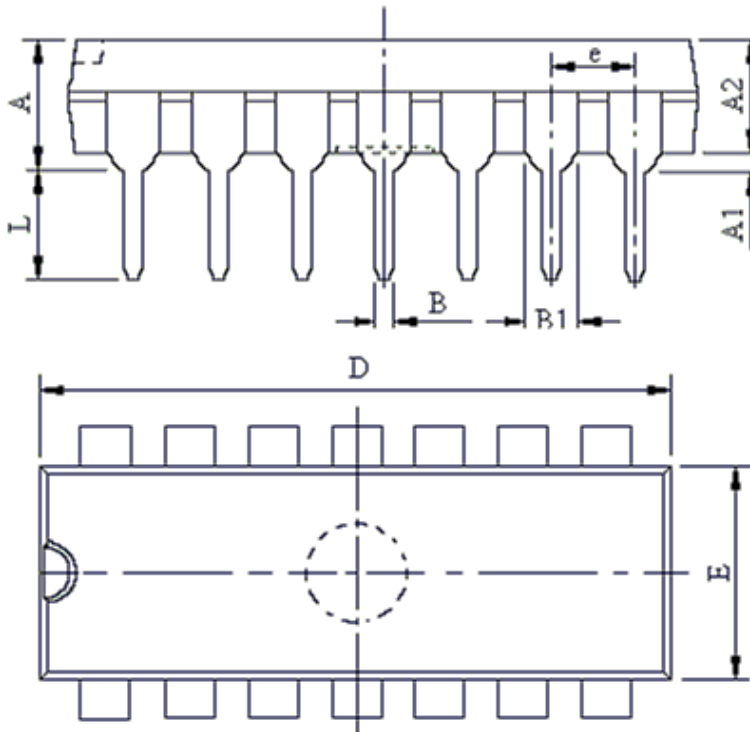
**14-pin DIP**

Note:  
 1) Controlling dimensions in millimeters.  
 2) Ref: JEDEC MS-001D/AA

PKG. DIMENSIONS(MM)		
SYMBOL	Min	Max
A	3.71	4.31
A1	0.51	
A2	3.20	3.60
B	0.38	0.57
B1	1.52 BSC	
c	0.20	0.36
D	18.80	19.20
E	6.20	6.60
E1	7.32	7.92
e	2.54 BSC	
L	3.00	3.60
E2	8.40	9.00

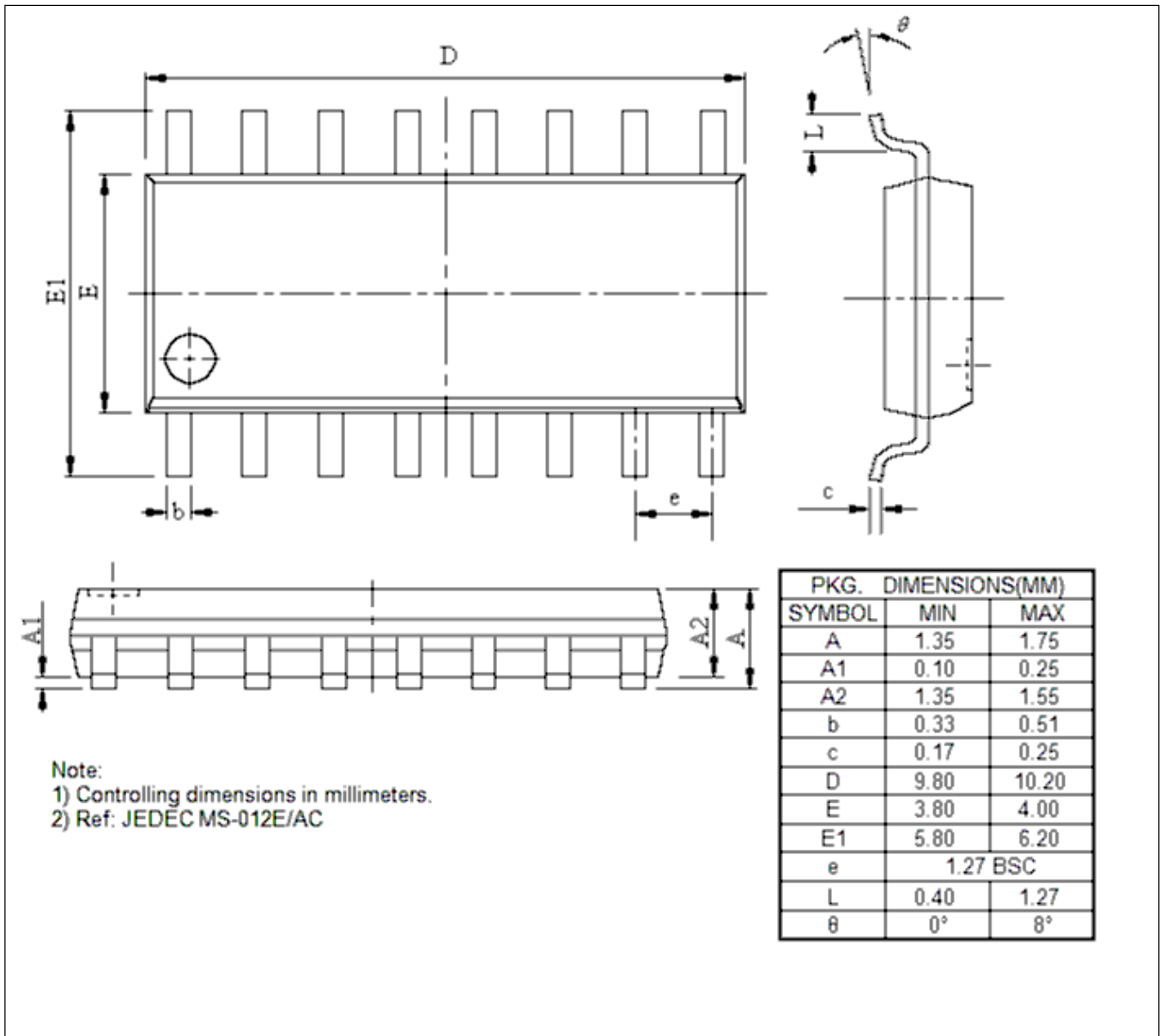
**16-pin SOIC**

16-pin DIP

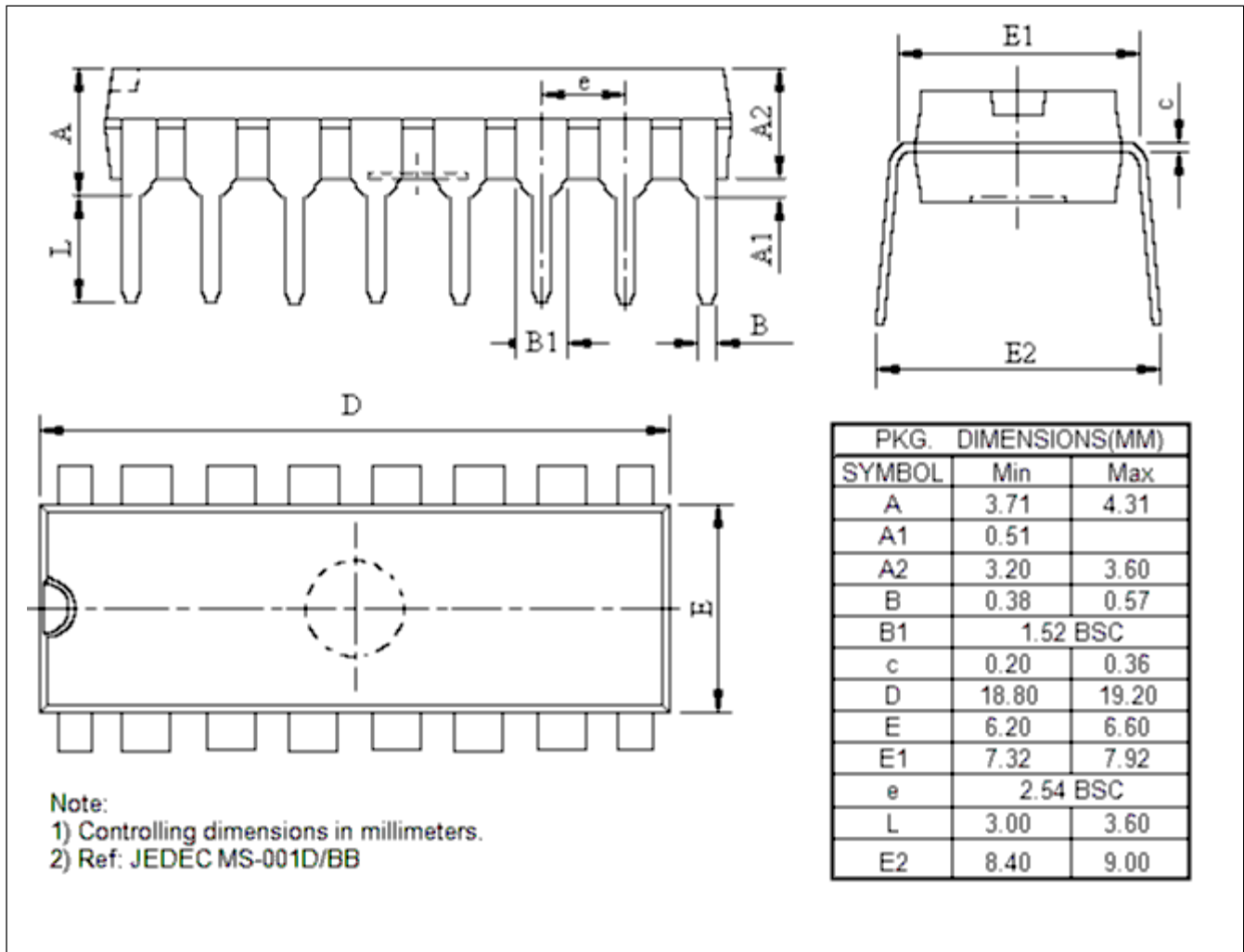

Pericom Semiconductor Corporation • 1-800-435-2336 • www.pericom.com

Pericom Technology Incorporation reserves the right to make changes to its products or specifications at any time, without notice, in order to improve design or performance and to supply the best possible product. Pericom Technology does not assume any responsibility for use of any circuitry described other than the circuitry embodied in Pericom Technology product. The company makes no representations that circuitry described herein is free from patent infringement or other rights, of Pericom.

## Looking for pricing, stock, or lifecycle information?

Click below to explore more details on WIN SOURCE:

-  [View PT8A977BWE on WIN SOURCE](#)
-  [Diodes Incorporated Information](#)

## Optimize Your Supply Chain with WIN SOURCE Solutions

-  Global Sourcing Solution
-  Obsolete Management
-  Cost Control Management
-  Shortage Management
-  Alternative Solution
-  Excess Inventory Management