

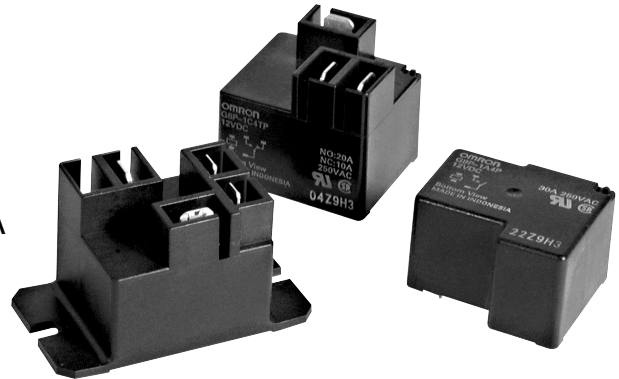

**THE DATASHEET OF
G8P-1CTP DC110**



- Up to 30 A switching capacity in compact package
- Available with quick-connect terminals for easy load connecting
- UL Class F coil insulation standard
- Complies with UL 873 and UL 508 column A spacings up to 300 V
- Minimum 6kV Impulse Surge Withstand
- Ideal for home and industrial appliances, HVAC (heating, ventilating, and air conditioning), and many other applications
- UL/CSA approvals, VDE pending



Ordering Information

To Order: Select the part number and add the desired coil voltage rating, (e.g., G8P-1A4P-DC12).

Mounting type	Contact form	Construction	Part number
PCB	SPST-NO	Open frame	G8P-1AP
		Sealed with ventable nib	G8P-1A4P
	SPDT	Open frame	G8P-1CP
		Sealed with ventable nib	G8P-1C4P
PCB & Quick Connect load terminals	SPST-NO	Open frame	G8P-1ATP
		Sealed with ventable nib	G8P-1A4TP
	SPDT	Open frame	G8P-1CTP
		Sealed with ventable nib	G8P-1C4TP
Flange mount Quick Connect terminals	SPST-NO	Vented	G8P-1A2T-F
	SPDT	Vented	G8P-1C2T-F

Note: Load terminals are .250" Quick Connect. Coil terminals on Flange Mount versions are .187" Quick Connect.

Specifications

CONTACT DATA

Type	SPST-NO	SPDT
Rated load	30 A at 250 VAC, 20 A at 28 VDC	20/10 A* at 250 VAC, 20/10 A at 28 VDC
Contact material	AgCdO	
Carry current	30 A	20/10 A*
Max. operating voltage	250 VAC, 28 VDC	
Max. operating current	AC 30 A, DC 20 A	AC 20/10 A, DC 20/10 A*
Max. switching capacity	7,500 VA, 560 W	5,000/2,500 VA, 560/280 W*
Min. permissible load	DC 5 V, 500 mA	

* NO contact/NC contact

■ COIL DATA

Rated voltage (VDC)	Rated current (mA)	Coil resistance (Ω)	Pick-up voltage	Dropout voltage	Maximum voltage	Power consumption (mW)
			% of rated voltage			
5	185	27	75% max.	10% min.	120% max.	Approx. 900
9	93	97				
12	77	155				
24	36	660				
48	19	2480				
110	9	12400				

Note: The rated current and coil resistance are measured at a coil temperature of 23°C (73°F) with tolerances of $\pm 10\%$.

■ CHARACTERISTICS

Contact resistance	100 m Ω max. (measured with 5 VDC, 1 A)	
Operate time	15 ms max.	
Release time	10 ms max.	
Insulation resistance	10 M Ω min. (at 500 VDC)	
Dielectric strength	2,500 VAC, 50/60 Hz for 1 minute (coil to contacts), 1,500 VAC, 50/60 Hz for 1 minute (between contacts)	
Impulse surge withstand	6,000 V between coil to contacts (1.2 μ s/50 μ s & 100 kHz ring wave per IEC 1000-4-12)	
Vibration	Mechanical durability	10 to 55 Hz, 1.65 mm (0.06 in) double amplitude for 2 hours
	Malfunction durability	10 to 55 Hz, 1.65 mm (0.06 in) double amplitude for 5 minutes
Shock	Mechanical durability	1,000 m/s ² (approx. 100 G)
	Malfunction durability	100 m/s ² (approx. 10 G)
Ambient temperature	-55° to 105°C (-67° to 221°F)	
Humidity	45% to 85% RH	
Service life	Mechanical	10 million operations minimum
	Electrical	100,000 operations at rated load (minimum)

Note: Data shown are of initial value. Operate and release times excluding bounce.

■ CHARACTERISTIC DATA

Maximum switching capacity SPST-NO

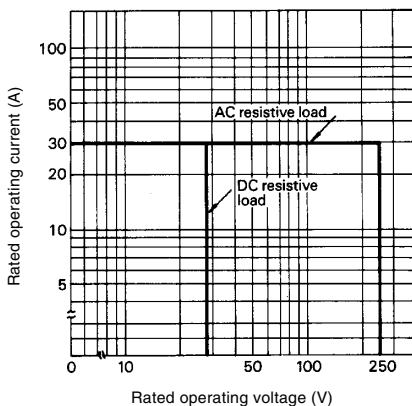

SPDT

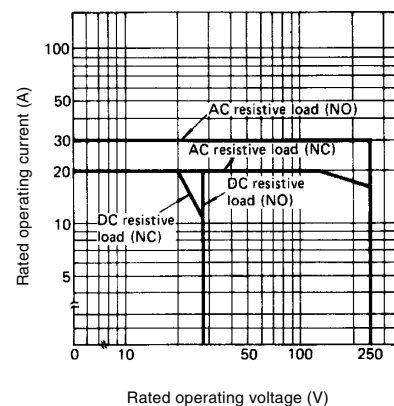

■ CHARACTERISTIC DATA

Electrical service life
SPST-NO

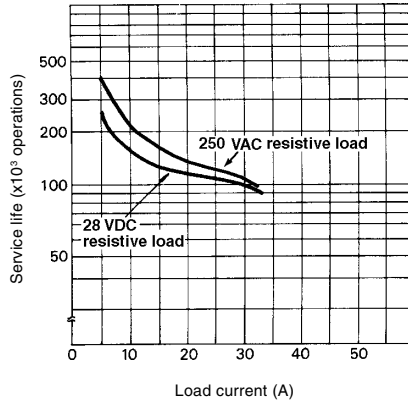

SPDT

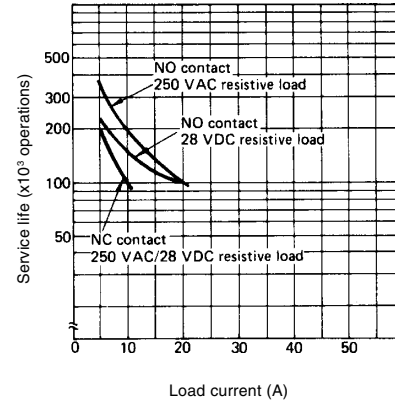

Dimensions

Unit: mm (inch)

■ RELAYS

Open frame, PCB terminals

Terminal arrangement/
Internal connections
(Bottom view)

Mounting holes
(Bottom view)

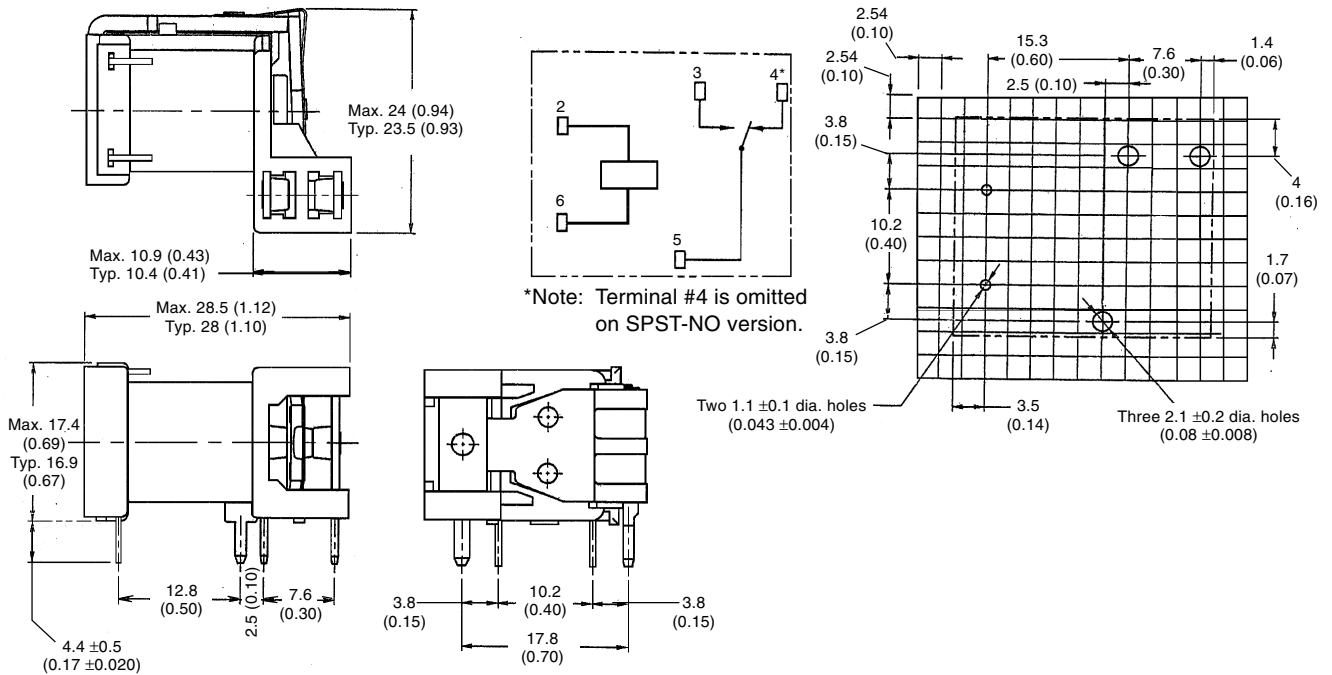

Unit: mm (inch)

Sealed, PCB terminals

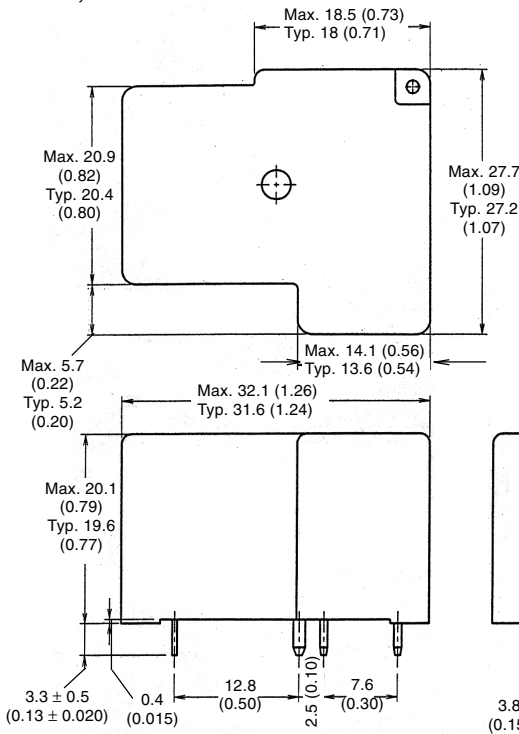

**Terminal arrangement/
Internal connections
(Bottom view)**

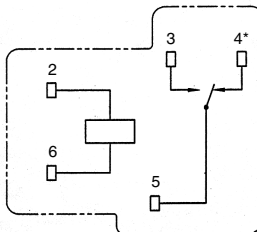

*Note: Terminal #4 is omitted on SPST-NO version.

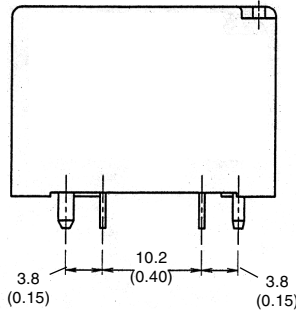

**Mounting holes
(Bottom view)**

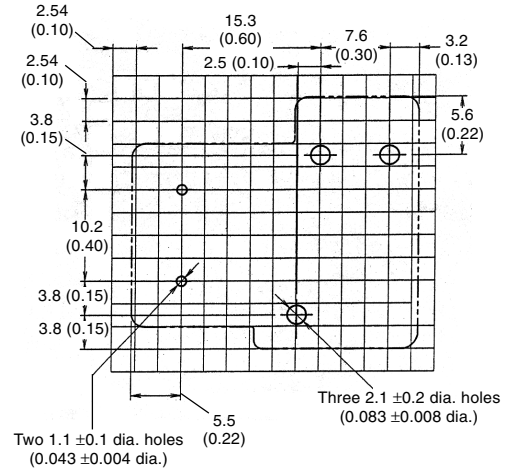

Open frame, PCB with Quick Connect terminals

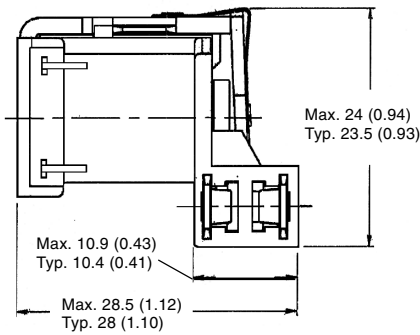

**Terminal arrangement/
Internal connections
(Bottom view)**

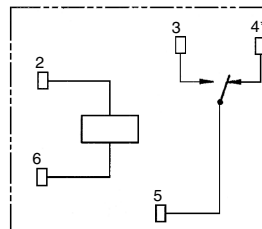

*Note: Terminal #4 is omitted on SPST-NO version.

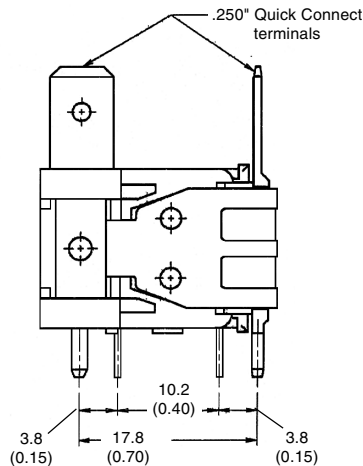

**Mounting holes
(Bottom view)**

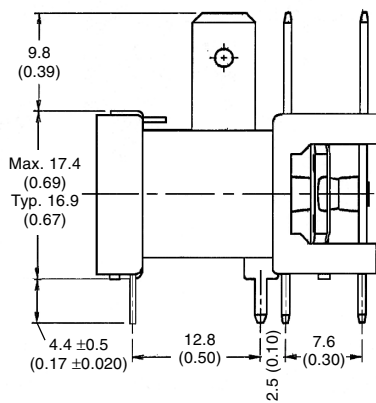
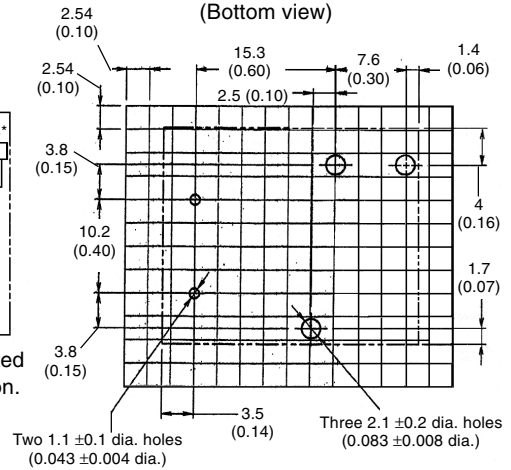

Unit: mm (inch)

Sealed, PCB with Quick Connect terminals

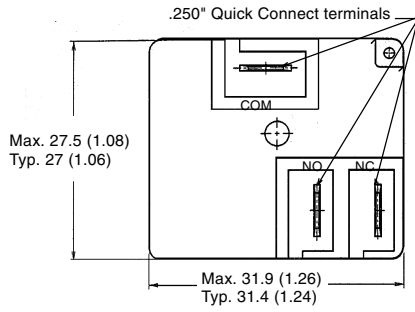

**Terminal arrangement/
Internal connections
(Bottom view)**

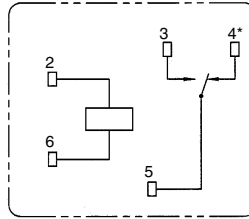

*Note: Terminal #4 is omitted on SPST-NO version.

**Mounting holes
(Bottom view)**

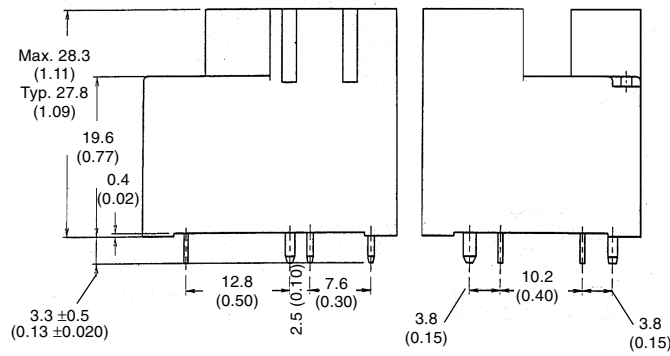
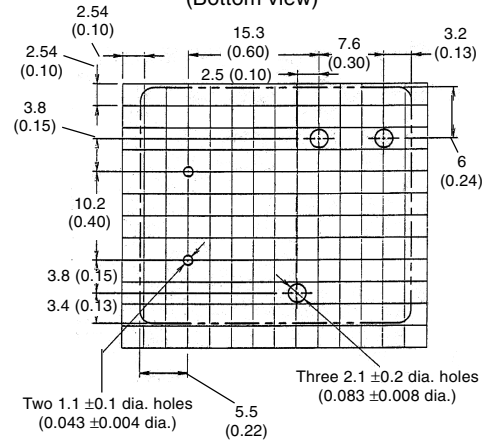

Flange mount

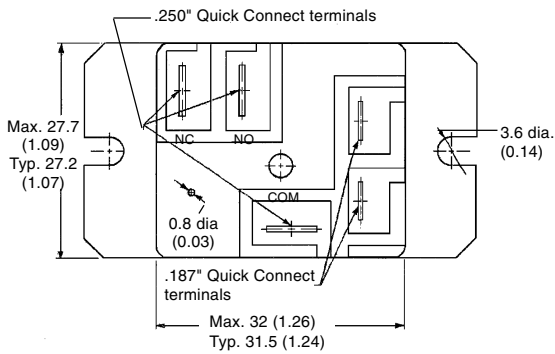

**Terminal arrangement/
Internal connections
(Bottom view)**

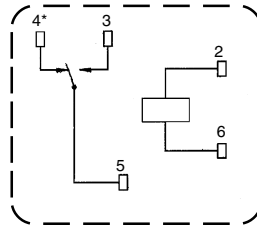

*Note: Terminal #4 is omitted on SPST-NO version.

**Mounting holes
(Bottom view)**

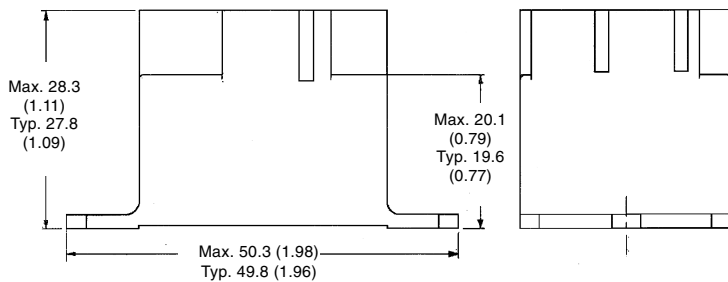
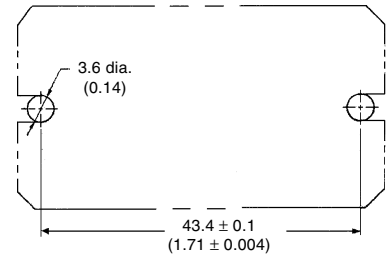

Note: Allow air circulation within the sealed type G8P by removing the ventilation nib from the cover after soldering and cleaning is complete.

■ **APPROVALS**

UL Recognized (File No. E41643), CSA Certified (File No. LR34815)

Contact form	Coil ratings	Contact ratings
SPST-NO	5 to 110 VDC	30A, 277 VAC (G.P./Res.) 30A, 250 VAC, 100k ops. (Res.) 20A, 120-240 VAC, 70°C, 100,000 cycles (G.P./Res.) 20A, 28 VDC (Res.) 20A, 240 VAC, 105°C, 100,000 cycles (Res.) 1 HP, 125-250 VAC 2 HP, 250 VAC A300 Pilot Duty 12FLA, 72LRA, 250 VAC, 100,000 cycles 20 FLA, 96 LRA, 125 VAC, 100,000 cycles 5A, 250 VAC (Tungsten) 20A, 120-277 VAC (Ballast)
SPDT	5 to 110 VDC	NO/NC 30A/ 30A, 250 VAC (Res.) 20A/ 15A, 120-240 VAC, 105°C, 100,000 cycles (Res.) 20A/ 10A, 120-240 VAC, 70°C, 100,000 cycles (G.P./Res.) 20A/ 10A, 28 VDC (Res.) 1/2 HP/ 1/2 HP, 125 VAC, 100,000 cycles 2 HP/ 1/2 HP, 250 VAC 1 HP/ 1/4 HP, 125 VAC B150 Pilot Duty 5A/ 3A, 250 VAC (Tungsten) 6A/ 3A, 277 VAC (Ballast)

- Note:
1. The rated values approved by each of the safety standards (e.g., UL, CSA) may be different from the performance characteristics individually defined in this catalog.
 2. For information on additional ratings not included in this catalog, contact your local Omron Representative.
 3. In the interest of product improvement, specifications are subject to change.





OMRON ELECTRONICS, INC.
 One East Commerce Drive
 Schaumburg, IL 60173
1-800-55-OMRON

OMRON CANADA, INC.
 885 Milner Avenue
 Scarborough, Ontario M1B 5V8
416-286-6465

Looking for pricing, stock, or lifecycle information?

Click below to explore more details on WIN SOURCE:

-  [View G8P-1CTP DC110 on WIN SOURCE](#)
-  [Omron Information](#)

Optimize Your Supply Chain with WIN SOURCE Solutions

-  Global Sourcing Solution
-  Obsolete Management
-  Cost Control Management
-  Shortage Management
-  Alternative Solution
-  Excess Inventory Management