



**THE DATASHEET OF  
TPS53125EVM-599**



# TPS53125 Dual Synchronous Step-Down Controller for Low Voltage Power Rails

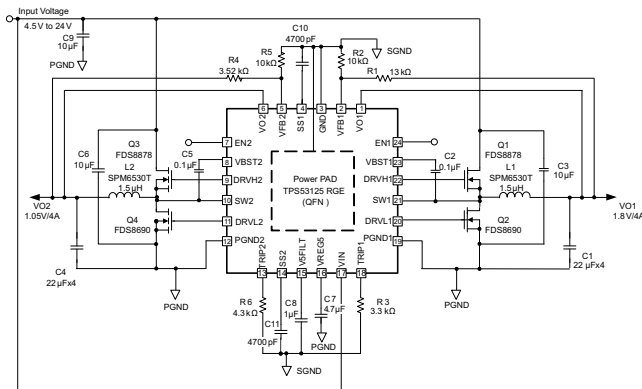
## 1 Features

- D-CAP2™ Mode Control
  - Fast Transient Response
  - No External Parts Required for Loop Compensation
  - Compatible With Ceramic Output Capacitors
- High Initial Reference Accuracy ( $\pm 1\%$ )
- Low Output Ripple
- Wide Input Voltage Range: 4.5 V to 24 V
- Output Voltage Range: 0.76 V to 5.5 V
- Low-Side  $R_{DS(ON)}$  Loss-Less Current Sensing
- Adaptive Gate Drivers with Integrated Boost Diode
- Adjustable Soft Start
- Non-Sinking Pre-Biased Soft Start
- 350-kHz Switching Frequency
- Cycle-by-Cycle Over-Current Limiting Control
- 30-mV to 300-mV OCP Threshold Voltage
- Thermally Compensated OCP by 4000 ppm/°C at  $I_{TRIP}$

## 2 Applications

- Point-of-Load Regulation in Low Power Systems for Wide Range of Applications
  - Digital TV Power Supply
  - Networking Home Terminal
  - Digital Set-Top Box (STB)
  - DVD Player/Recorder
  - Gaming Consoles

## 4 Simplified Schematics



## 3 Description

The TPS53125 is a dual, adaptive on-time D-CAP2™ mode synchronous buck controller. The part enables system designers to cost effectively complete the suite of various end equipment's power bus regulators with a low external component count and low standby consumption. The main control loop for the TPS53125 uses the D-CAP™ Mode topology which provides a very fast transient response with no external component.

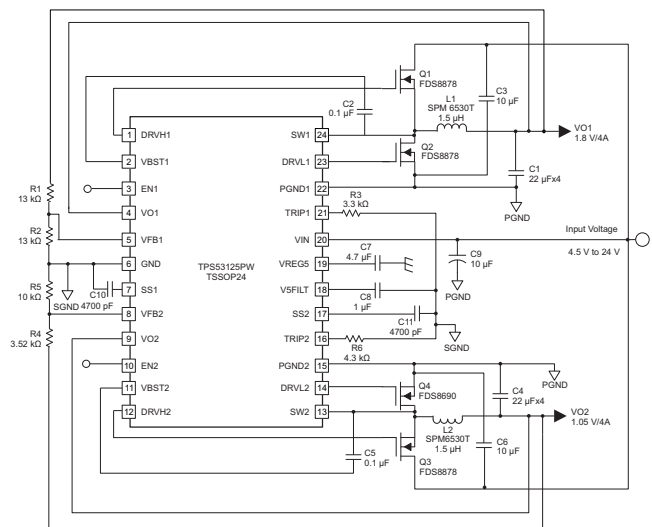
The TPS53125 also has a proprietary circuit that enables the device to adapt not only low equivalent series resistance (ESR) output capacitors such as POSCAP/SP-CAP, but also ceramic capacitor. The part provides a convenient and efficient operation with conversion voltages from 4.5 V to 24 V and output voltage from 0.76 V to 5.5 V.

The TPS53125 is available in 24-pin RGE and PW packages, and is specified from  $-40^{\circ}\text{C}$  to  $85^{\circ}\text{C}$  ambient temperature range.

### Device Information<sup>(1)</sup>

DEVICE NAME	PACKAGE	BODY SIZE
TPS53125	VQFN (24)	4 mm x 4 mm
	TSSOP (24)	4.4 mm x 7.8 mm

(1) For all available packages, see the orderable addendum at the end of the datasheet.



## Table of Contents

<b>1 Features</b> .....	<b>1</b>	8.3 Feature Description.....	<b>9</b>
<b>2 Applications</b> .....	<b>1</b>	8.4 Device Functional Modes .....	<b>11</b>
<b>3 Description</b> .....	<b>1</b>	<b>9 Application and Implementation</b> .....	<b>12</b>
<b>4 Simplified Schematics</b> .....	<b>1</b>	9.1 Application Information .....	<b>12</b>
<b>5 Revision History</b> .....	<b>2</b>	9.2 Typical Application .....	<b>12</b>
<b>6 Pin Configuration and Functions</b> .....	<b>3</b>	9.3 Typical Application Circuit, TSSOP.....	<b>19</b>
<b>7 Specifications</b> .....	<b>4</b>	<b>10 Power Supply Recommendations</b> .....	<b>20</b>
7.1 Absolute Maximum Ratings .....	<b>4</b>	<b>11 Layout</b> .....	<b>21</b>
7.2 Handling Ratings.....	<b>4</b>	11.1 Layout Suggestions.....	<b>21</b>
7.3 Recommended Operating Conditions.....	<b>4</b>	11.2 Layout Example .....	<b>22</b>
7.4 Thermal Information .....	<b>5</b>	<b>12 Device and Documentation Support</b> .....	<b>23</b>
7.5 Electrical Characteristics.....	<b>5</b>	12.1 Trademarks .....	<b>23</b>
7.6 Typical Characteristics.....	<b>7</b>	12.2 Electrostatic Discharge Caution.....	<b>23</b>
<b>8 Detailed Description</b> .....	<b>8</b>	12.3 Glossary .....	<b>23</b>
8.1 Overview .....	<b>8</b>	<b>13 Mechanical, Packaging, and Orderable</b>	
8.2 Functional Block Diagrams .....	<b>8</b>	<b>Information</b> .....	<b>23</b>

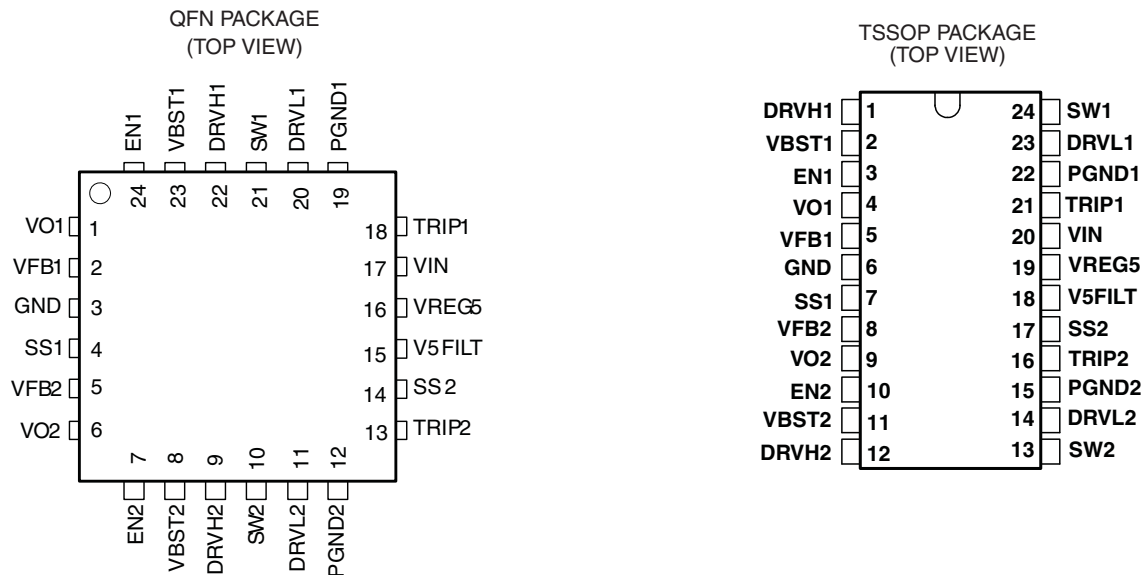
## 5 Revision History

### Changes from Revision B (January 2010) to Revision C

Page

• Changed revision from B-January 2010 to C-May 2014, also copied all text, tables and graphics to new data sheet template .....	<b>1</b>
• Added $V_{(ESD)}$ value .....	<b>4</b>
• Changed VREG5 row, Min column from 4.8 to 4.6 in ELEC CHARA table, .....	<b>5</b>
• Changed Changed the $R_{DRVL}$ MAX value for –100 mA From: 8 $\Omega$ To 12 $\Omega$ .....	<b>5</b>
• Changed the I(SSC) Min value From: -1.5 to -2.5 $\mu$ A and the Max value From: -2.5 To: -1.5 $\mu$ A .....	<b>6</b>
• Added Application Curves section .....	<b>19</b>

## 6 Pin Configuration and Functions



### Pin Functions

NAME	PIN		I/O	DESCRIPTION
	QFN 24	TSSOP 24		
VBST1, VBST2	23, 8	2, 11	I	Supply input for high-side NFET driver. Bypass to SWx with a high-quality 0.1- $\mu$ F ceramic capacitor. An external Schottky diode can be added from VREG5 if forward drop is critical to drive the high-side FET.
EN1, EN2	24, 7	3, 10	I	Enable. Pull High to enable SMPS.
VO1, VO2	1, 6	4, 9	I	Output voltage inputs for on-time adjustment and output discharge. Connect directly to the output voltage.
VFB1, VFB2	2, 5	5, 8	I	D-CAP2 feedback inputs. Connect to output voltage with resistor divider.
GND	3	6	I	Signal ground pin. Connect to PGND1, PGND2 and system ground at a single point.
DRVH1, DRVH2	22, 9	1, 12	O	High-side N-Channel MOSFET gate driver outputs. SWx referenced drivers switch between SWx (OFF) and VBSTx (ON).
SW1, SW2	21, 10	24, 13	I/O	Switch node connections for both the high-side drivers and the over current comparators.
DRVL1, DRVL2	20, 11	23, 14	O	Low-side N-Channel MOSFET gate driver outputs. PGND referenced drivers switch between PGNDx (OFF) and VREG5 (ON).
PGND1, PGND2	19, 12	22, 15	I/O	Power ground connections for both the low-side drivers and the over current comparators. Connect PGND1, PGND2 and GND strongly together near the IC.
TRIP1, TRIP2	18, 13	21, 16	I	Over current threshold programming pin. Connect to GND with a resistor to GND to set threshold for low-side $R_{DS(ON)}$ current limit.
VIN	17	20	I	Supply Input for 5-V linear regulator. Bypass to GND with a minimum high-quality 0.1- $\mu$ F ceramic capacitor.
V5FILT	15	18	I	5-V supply input for the entire control circuitry except the MOSFET drivers. Bypass to GND with a minimum high-quality 1.0- $\mu$ F ceramic capacitor. V5FILT is connected to VREG5 via an internal 10- $\Omega$ resistor.
VREG5	16	19	O	Output of 5-V linear regulator and supply for MOSFET drivers. Bypass to GND with a minimum high-quality 4.7- $\mu$ F ceramic capacitor. VREG5 is connected to V5FILT via an internal 10- $\Omega$ resistor.
SS1, SS2	4, 14	7, 17	O	Soft-start programming pin. Connect capacitor from SSx pin to GND to program soft-start time.

## 7 Specifications

### 7.1 Absolute Maximum Ratings

 over operating free-air temperature range (unless otherwise noted) <sup>(1)</sup>

		MIN	MAX	UNIT	
V <sub>I</sub>	Input voltage	VIN, EN1, EN2	-0.3	26	V
		VBST1, VBST2	-0.3	32	
		VBST1 - SW1, VBST2 - SW2	-0.3	6	
		V5FILT, VFB1, VFB2, TRIP1, TRIP2, VO1, VO2	-0.3	6	
		SW1, SW2	-2	26	
V <sub>O</sub>	Output voltage	DRVH1, DRVH2	-1	32	V
		DRVH1 - SW1, DRVH2 - SW2	-0.3	6	
		DRVL1, DRVL2, VREG5, SS1, SS2	-0.3	6	
		PGND1, PGND2	-0.3	0.3	
T <sub>A</sub>	Operating ambient temperature	-40	85	°C	
T <sub>J</sub>	Junction temperature	-40	150	°C	

(1) Stresses beyond those listed under *Absolute Maximum Ratings* may cause permanent damage to the device. These are stress ratings only, which do not imply functional operation of the device at these or any other conditions beyond those indicated under *Recommended Operating Conditions*. Exposure to absolute-maximum-rated conditions for extended periods may affect device reliability.

### 7.2 Handling Ratings

		MIN	MAX	UNIT	
T <sub>stg</sub>	Storage temperature range	-55	150	°C	
V <sub>(ESD)</sub>	Electrostatic discharge	Human body model (HBM), per AN/ESDA/JEDEC JS-001, all pins <sup>(1)</sup>	-2000	2000	V
		Charged device model (CDM), per JEDEC specification JESD22-C101, all pins <sup>(2)</sup>	-500	500	V

(1) JEDEC document JEP155 states that 500-V HBM allows safe manufacturing with a standard ESD control process.

(2) JEDEC document JEP157 states that 250-V CDM allows safe manufacturing with a standard ESD control process.

### 7.3 Recommended Operating Conditions

over operating free-air temperature range (unless otherwise noted)

		MIN	MAX	UNIT	
V <sub>IN</sub>	Supply input voltage	VIN	4.5	24	V
		V5FILT	4.5	5.5	
V <sub>I</sub>	Input voltage	VBST1, VBST2	-0.1	30	V
		VBST1 - SW1, VBST2 - SW2	-0.1	5.5	
		VFB1, VFB2, VO1, VO2	-0.1	5.5	
		TRIP1, TRIP2	-0.1	0.3	
		EN1, EN2	-0.1	24	
		SW1, SW2	-1.8	24	
V <sub>O</sub>	Output voltage	DRVH1, DRVH2	-0.1	30	V
		VBST1 - SW1, VBST2 - SW2	-0.1	5.5	
		DRVL1, DRVL2, VREG5, SS1, SS2	-0.1	5.5	
		PGND1, PGND2	-0.1	0.1	
T <sub>A</sub>	Operating free-air temperature	-40	85	°C	
T <sub>J</sub>	Operating junction temperature	-40	125	°C	

## 7.4 Thermal Information

THERMAL METRIC <sup>(1)</sup>		TPS53125		UNIT
		PW 24 PINS	RGE 24 PINS	
R <sub>θJA</sub>	Junction-to-ambient thermal resistance	88.9	35.4	°C/W
R <sub>θJC(top)</sub>	Junction-to-case (top) thermal resistance	26.5	39.1	
R <sub>θJB</sub>	Junction-to-board thermal resistance	43.5	13.6	
ψ <sub>JT</sub>	Junction-to-top characterization parameter	1.1	0.5	
ψ <sub>JB</sub>	Junction-to-board characterization parameter	43.0	13.6	
R <sub>θJC(bot)</sub>	Junction-to-case (bottom) thermal resistance	n/a	3.8	

(1) For more information about traditional and new thermal metrics, see the *IC Package Thermal Metrics* application report, [SPRA953](#).

## 7.5 Electrical Characteristics

over operating free-air temperature range (unless otherwise noted)

PARAMETER		TEST CONDITIONS	MIN	TYP	MAX	UNIT
<b>SUPPLY CURRENT</b>						
I <sub>IN</sub>	VIN supply current	VIN current, T <sub>A</sub> = 25°C, VREG5 tied to V5FILT, EN1 = EN2 = 5 V, VFB1 = VFB2 = 0.8 V, SW1 = SW2 = 0.5 V		450	800	μA
I <sub>VINSDN</sub>	VIN shutdown current	VIN current, T <sub>A</sub> = 25°C, no load, EN1 = EN2 = 0 V, VREG5 = ON		30	60	μA
<b>VFB VOLTAGE AND DISCHARGE RESISTANCE</b>						
V <sub>BG</sub>	Bandgap initial regulation accuracy	T <sub>A</sub> = 25°C	-1		1	%
V <sub>VFBTHx</sub>	VFBx threshold voltage	T <sub>A</sub> = 25°C, SW <sub>inj</sub> = OFF	755	765	775	mV
		T <sub>A</sub> = 0°C to 70°C, SW <sub>inj</sub> = OFF <sup>(1)</sup>	753.5		776.5	
		T <sub>A</sub> = -40°C to 85°C, SW <sub>inj</sub> = OFF <sup>(1)</sup>	752		778	
I <sub>VFB</sub>	VFB input current	VFBx = 0.8 V, T <sub>A</sub> = 25°C	-100	-10	100	nA
R <sub>Dischg</sub>	VO discharge resistance	ENx = 0 V, VOx = 0.5 V, T <sub>A</sub> = 25°C		40	80	Ω
<b>VREG5 OUTPUT</b>						
V <sub>VREG5</sub>	VREG5 output voltage	T <sub>A</sub> = 25°C, 5.5 V < VIN < 24 V, 0 < I <sub>VREG5</sub> < 10 mA	4.6	5.0	5.2	V
V <sub>LN5</sub>	Line regulation	5.5 V < VIN < 24 V, I <sub>VREG5</sub> = 10 mA			20	mV
V <sub>LD5</sub>	Load regulation	1 mA < I <sub>VREG5</sub> < 10 mA			40	mV
I <sub>VREG5</sub>	Output current	VIN = 5.5 V, V <sub>VREG5</sub> = 4.0 V, T <sub>A</sub> = 25°C		170		mA
<b>OUTPUT: N-CHANNEL MOSFET GATE DRIVERS</b>						
R <sub>DRVH</sub>	DRVH resistance	Source, I <sub>DRVHx</sub> = -100 mA		5.5	11	Ω
		Sink, I <sub>DRVHx</sub> = 100 mA		2.5	5	
R <sub>DRVL</sub>	DRVL resistance	Source, I <sub>DRVLx</sub> = -100 mA		4	12	Ω
		Sink, I <sub>DRVLx</sub> = 100 mA		2	4	
T <sub>D</sub>	Dead time	DRVHx-low to DRVLx-on	20	50	80	ns
		DRVLx-low to DRVHx-on	20	40	80	
<b>INTERNAL BOOST DIODE</b>						
V <sub>FBST</sub>	Forward voltage	V <sub>VREG5-VBSTx</sub> , I <sub>F</sub> = 10 mA, T <sub>A</sub> = 25°C	0.7	0.8	0.9	V
I <sub>VBSTLK</sub>	VBST leakage current	VBSTx = 29 V, SWx = 24 V, T <sub>A</sub> = 25°C		0.1	1	μA
<b>ON-TIME TIMER CONTROL</b>						
T <sub>ON1L</sub>	CH1 on time	SW1 = 12 V, VO1 = 1.8 V		490		ns
T <sub>ON2L</sub>	CH2 on time	SW2 = 12 V, VO2 = 1.8 V		390		ns
T <sub>OFF1L</sub>	CH1 min off time	SW1 = 0.7 V, T <sub>A</sub> = 25°C, VFB1 = 0.7 V		285		ns
T <sub>OFF2L</sub>	CH2 min off time	SW2 = 0.7 V, T <sub>A</sub> = 25°C, VFB2 = 0.7 V		285		ns

(1) Not production tested - ensured by design.

**Electrical Characteristics (continued)**

over operating free-air temperature range (unless otherwise noted)

PARAMETER		TEST CONDITIONS	MIN	TYP	MAX	UNIT
<b>SOFT START</b>						
$I_{SSC}$	SS1/SS2 charge current	$V_{SS1}/V_{SS2} = 0\text{ V}$ , $T_A = 25^\circ\text{C}$	-2.5	-2	-1.5	$\mu\text{A}$
$TC_{ISSC}$	$I_{SSC}$ temperature coefficient	On the basis of $25^\circ\text{C}^{(1)}$	-4		3	$\text{nA}/^\circ\text{C}$
$I_{SSD}$	SS1/SS2 discharge current	$V_{SS1}/V_{SS2} = 0.5\text{ V}$	100	150		$\mu\text{A}$
<b>UVLO</b>						
$V_{UV5VFILT}$	V5FILT UVLO threshold	Wake up	3.7	4.0	4.3	V
		Hysteresis	0.2	0.3	0.4	
<b>LOGIC THRESHOLD</b>						
$V_{ENH}$	ENx high-level input voltage	EN 1/2	2.0			V
$V_{ENL}$	ENx low-level input voltage	EN 1/2			0.3	V
<b>CURRENT SENSE</b>						
$I_{TRIP}$	TRIP source current	$V_{TRIPx} = 0.1\text{ V}$ , $T_A = 25^\circ\text{C}$	8.5	10	11.5	$\mu\text{A}$
$TC_{ITRIP}$	$I_{TRIP}$ temperature coefficient	On the basis of $25^\circ\text{C}$		4000		$\text{ppm}/^\circ\text{C}$
$V_{OClOff}$	OCP compensation offset	$(V_{TRIPx-GND} - V_{PGNDx-SWx})$ voltage, $V_{TRIPx-GND} = 60\text{ mV}$ , $T_A = 25^\circ\text{C}$	-15	0	15	mV
		$(V_{TRIPx-GND} - V_{PGNDx-SWx})$ voltage, $V_{TRIPx-GND} = 60\text{ mV}$	-20		20	
$V_{Rtrip}$	Current limit threshold setting range	$V_{TRIPx-GND}$ voltage	30		300	mV
<b>OUTPUT UNDERVOLTAGE AND OVERVOLTAGE PROTECTION</b>						
$V_{OVP}$	Output OVP trip threshold	OVP detect	110	115	120	%
$T_{OVPDEL}$	Output OVP prop delay			1.5		$\mu\text{s}$
$V_{UVP}$	Output UVP trip threshold	UVP detect	65	70	75	%
		Hysteresis (recover < 20 $\mu\text{s}$ )		10		
$T_{UVPDEL}$	Output UVP delay		17	30	40	$\mu\text{s}$
$T_{UVPEN}$	Output UVP enable delay	UVP enable delay / soft-start time	x1.4	x1.7	x2.0	ms
<b>THERMAL SHUTDOWN</b>						
$T_{SDN}$	Thermal shutdown threshold	Shutdown temperature <sup>(1)</sup>		150		$^\circ\text{C}$
		Hysteresis <sup>(1)</sup>		20		

## 7.6 Typical Characteristics

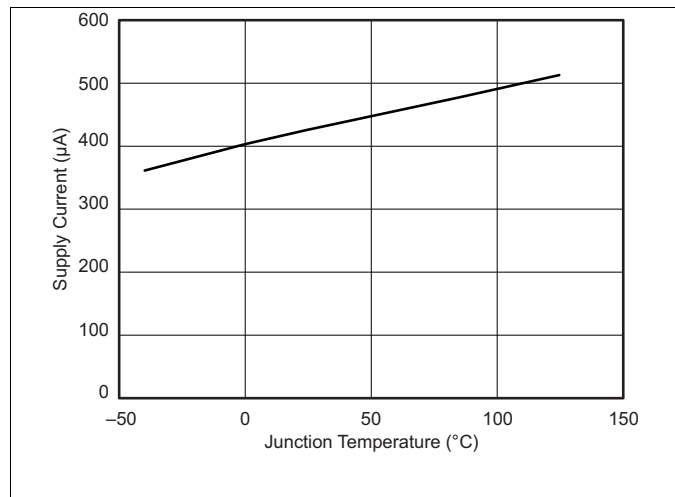


Figure 1. VIN Supply Current vs Junction Temperature

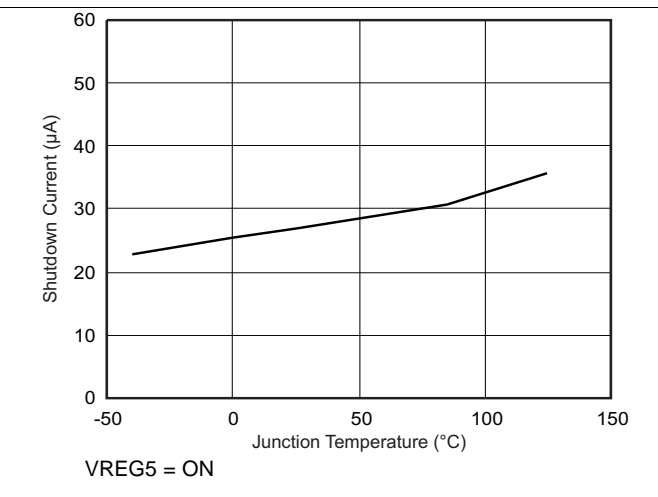


Figure 2. VIN Shutdown Current vs Junction Temperature

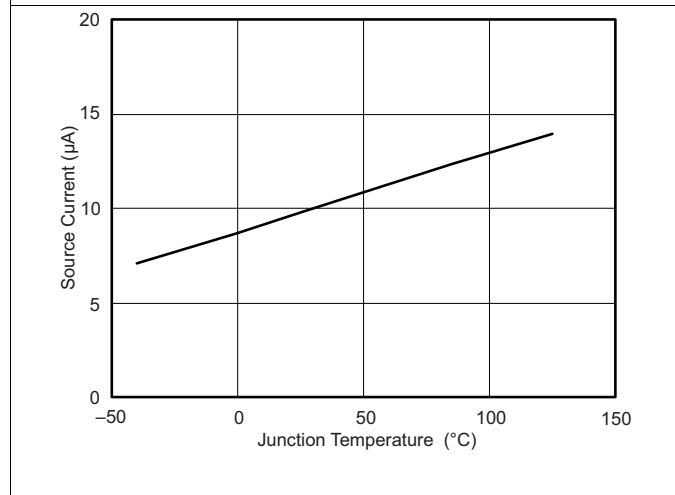


Figure 3. Trip Source Current vs Junction Temperature

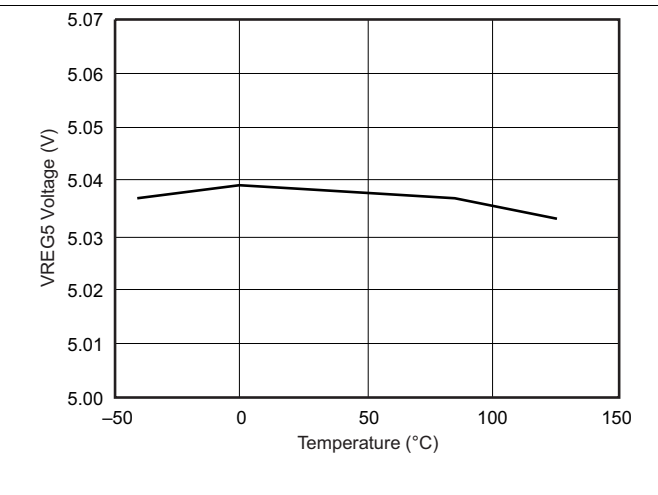


Figure 4. VREG5 Voltage vs Junction Temperature

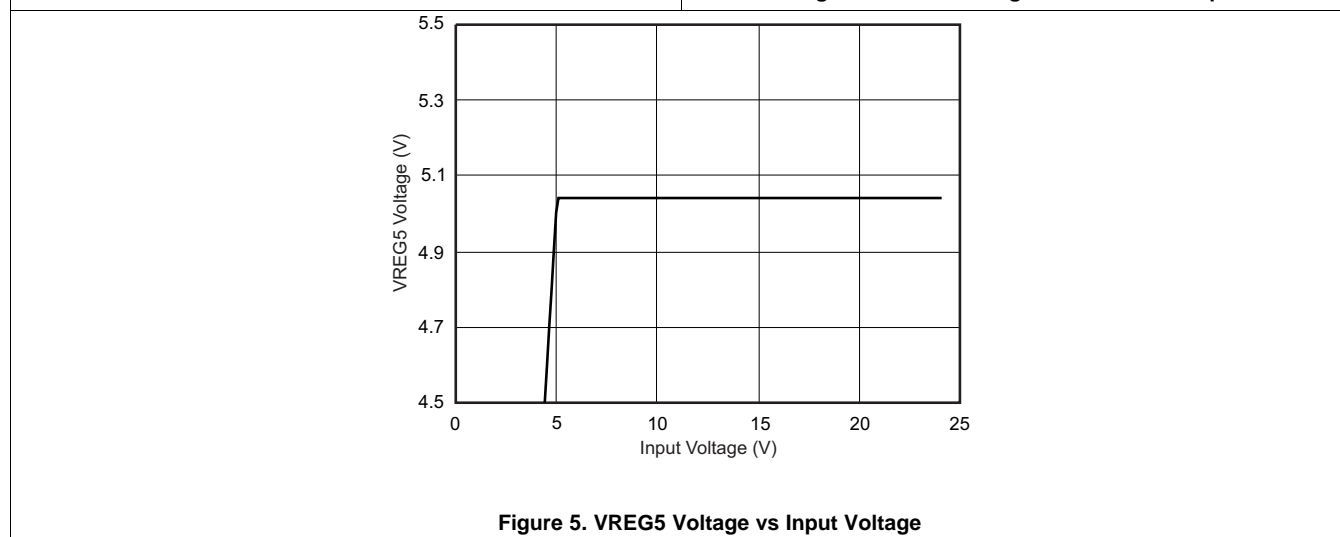


Figure 5. VREG5 Voltage vs Input Voltage

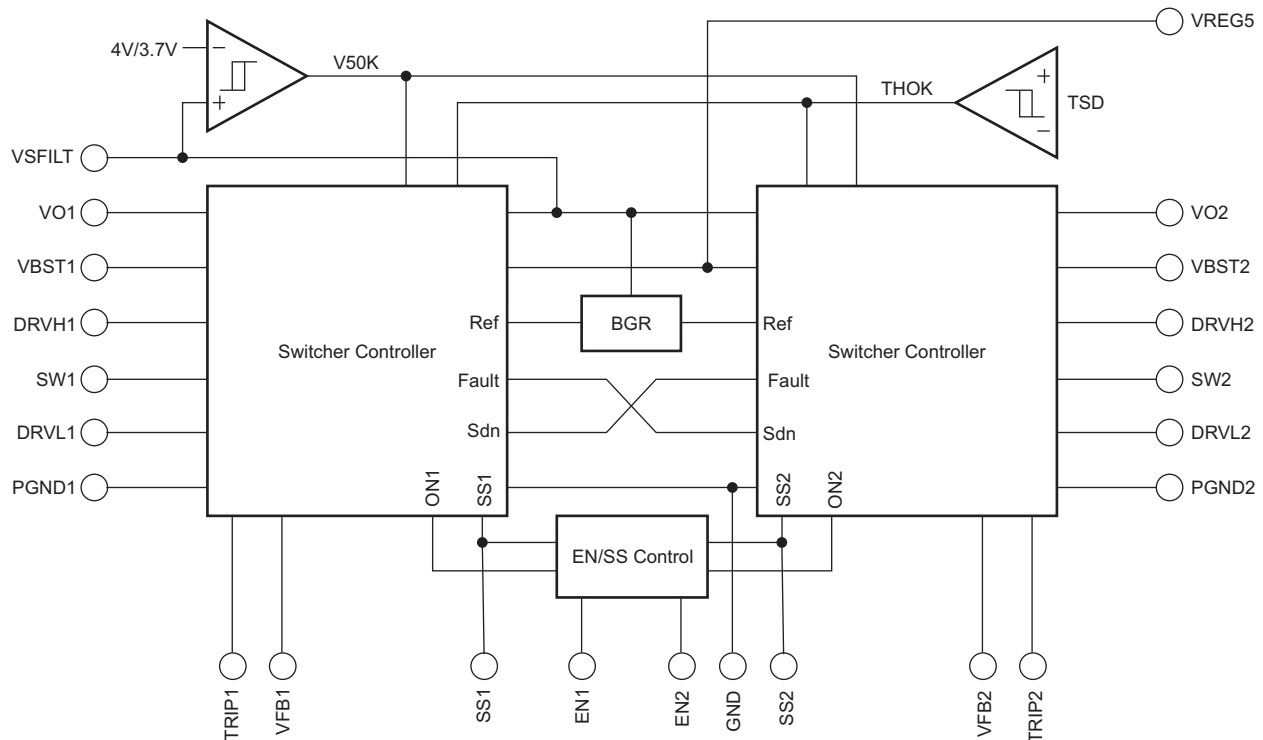
## 8 Detailed Description

### 8.1 Overview

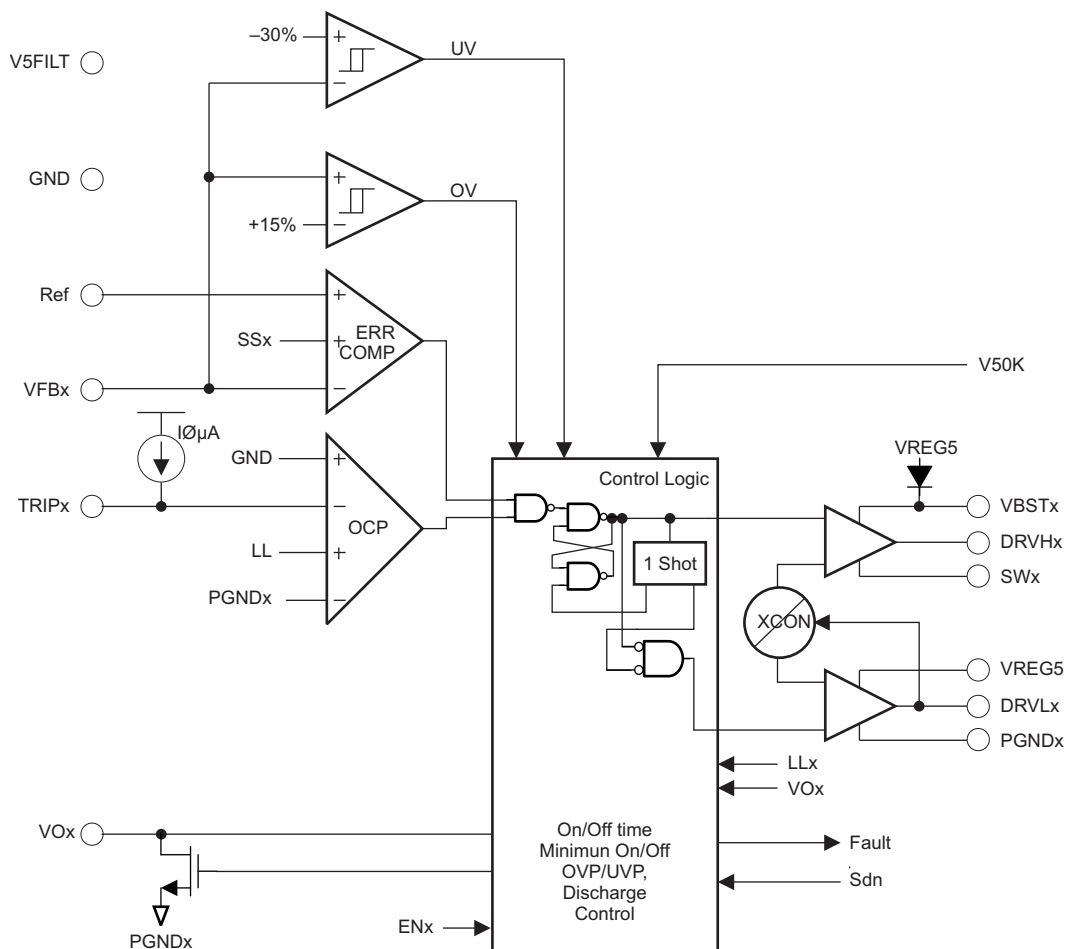
The TPS53125 is a dual, adaptive on-time D-CAP2™ mode synchronous buck controller. The part enables system designers to cost effectively complete the suite of various end equipment's power bus regulators with a low external component count and low standby consumption. The main control loop for the TPS53125 uses the D-CAP™ Mode topology which provides a very fast transient response with no external component.

The TPS53125 also has a proprietary circuit that enables the device to adapt not only low equivalent series resistance (ESR) output capacitors such as POSCAP/SP-CAP, but also ceramic capacitor. The part provides a convenient and efficient operation with conversion voltages from 4.5 V to 24 V and output voltage from 0.76 V to 5.5 V.

### 8.2 Functional Block Diagrams



## Functional Block Diagrams (continued)



## 8.3 Feature Description

### 8.3.1 PWM Operation

The main control loop of the TPS53125 is an adaptive on-time pulse width modulation (PWM) controller using a proprietary D-CAP2™ mode control. D-CAP2™ mode control combines constant on-time control with an internal compensation circuit for pseudo-fixed frequency and low external component count configuration with both low ESR and ceramic output capacitors. It is stable even with virtually no ripple at the output.

At the beginning of each cycle, the synchronous high-side MOSFET is turned on. After an internal one-shot timer expires, this MOSFET is turned off. When the feedback voltage falls below the reference voltage, the one-shot timer is reset and the high-side MOSFET is turned back on. The one shot is set by the converter input voltage VIN, and the output voltage VO, to maintain a pseudo-fixed frequency over the input voltage range. An internal ramp is added to the reference voltage to simulate output ripple, eliminating the need for ESR induced output ripple from D-CAP mode control.

### 8.3.2 Drivers

Each channel of the TPS53125 contains two high-current resistive MOSFET gate drivers. The low-side driver is a PGND referenced, VREG5 powered driver designed to drive the gate of a high-current, low  $R_{DS(ON)}$  N-channel MOSFET whose source is connected to PGND. The high-side driver is a floating SWx referenced VBST powered driver designed to drive the gate of a high-current, low  $R_{DS(ON)}$  N-channel MOSFET. To maintain the VBST voltage during the high-side driver ON time, a capacitor is placed from SWx to VBSTx. Each driver draws average current equal to gate charge ( $Q_g$  at  $V_{gs} = 5\text{ V}$ ) times switching frequency ( $f_{SW}$ ).

## Feature Description (continued)

To prevent cross-conduction, there is a narrow dead-time when both high-side and low-side drivers are OFF between each driver transition. During this time the inductor current is carried by one of the MOSFETs body diodes.

### 8.3.3 PWM Frequency and Adaptive On-Time Control

TPS53125 employs adaptive on-time control scheme and does not have a dedicated on board oscillator.

TPS53125 runs with pseudo-constant frequency by using the input voltage and output voltage to set the on-time one-shot timer. The on-time is inversely proportional to the input voltage and proportional to the output voltage. Therefore, when the duty ratio is  $V_{OUT}/V_{IN}$ , the frequency is constant.

### 8.3.4 5-Volt Regulator

The TPS53125 has an internal 5-V low-dropout (LDO) regulator to provide a regulated voltage for all both drivers and the IC's internal logic. A high-quality 4.7- $\mu$ F or greater ceramic capacitor from VREG5 to GND is required to stabilize the internal regulator. An internal 10- $\Omega$  resistor from VREG5 filters the regulator output to the IC's analog and logic input voltage, V5FILT. An additional high-quality 1.0- $\mu$ F ceramic capacitor is required from V5FILT to GND to filter switching noise from VREG5.

### 8.3.5 Soft Start

The TPS53125 has a programmable soft-start. When the ENx pin becomes high, 2.0- $\mu$ A current begins charging the capacitor connected from the SS pin to GND. The internal reference for the D-CAP2™ mode control comparator is overridden by the soft-start voltage until the soft-start voltage is greater than the internal reference for smooth control of the output voltage during start up.

### 8.3.6 Pre-Bias Support

The TPS53125 supports pre-bias start-up without sinking current from the output capacitor. When enabled, the low-side driver is held off until the soft-start commands a voltage higher than the pre-bias level (internal soft-start becomes greater than feedback voltage (VFB)), then the TPS53125 slowly activates synchronous rectification by limiting the first DRV1 pulses with a narrow on-time. This limited on-time is then incremented on a cycle-by-cycle basis until it coincides with the full 1-D off-time. This scheme prevents the initial sinking of current from the pre-bias output, and ensure that the output voltage (VOUT) starts and ramps up smoothly into regulation and the control loop is given time to transition from pre-biased start-up to normal mode operation.

### 8.3.7 Output Discharge Control

TPS53125 discharges the outputs when ENx is low, or the controller is turned off by the protection functions (OVP, UVP, UVLO, and thermal shutdown). The device discharges output using an internal 40- $\Omega$  MOSFET which is connected to VOx and PGNDx. The external low-side MOSFET is not turned on during the output discharge operation to avoid the possibility of causing negative voltage at the output. This discharge ensures that on start the regulated voltage always initializes from 0 V.

### 8.3.8 Over Current Limit

TPS53125 has cycle-by-cycle over current limit feature. The over current limits the inductor valley current by monitoring the voltage drop across the low-side MOSFET  $R_{DS(ON)}$  during the low-side driver on-time. If the inductor current is larger than the over current limit (OCL), the TPS53125 delays the start of the next switching cycle until the sensed inductor current falls below the OCL current. MOSFET  $R_{DS(ON)}$  current sensing is used to provide an accuracy and cost effective solution without external devices. To program the OCL, the TRIP pin should be connected to GND through a trip voltage setting resistor, according to the following equations.

$$V_{TRIP} = \left( I_{OCL} - \frac{(V_{IN} - V_O)}{2 \times L1 \times f_{SW}} \times \frac{V_O}{V_{IN}} \right) \times R_{DS(ON)} \quad (1)$$

$$R_{TRIP}(k\Omega) = \frac{V_{TRIP}(mV)}{I_{TRIP}(\mu A)} \quad (2)$$

## Feature Description (continued)

The trip voltage should be between 30 mV to 300 mV over all operational temperature, including the 4000-ppm/°C temperature slope compensation for the temperature dependency of the  $R_{DS(ON)}$ .

If the load current exceeds the over current limit, the voltage will begin to drop. If the over current conditions continues the output voltage will fall below the under voltage protection threshold and the TPS53125 will shut down.

In an over current condition, the current to the load exceeds the current to the output capacitor; thus the output voltage tends to fall off. Eventually, it will end up with crossing the under voltage protection threshold and shutdown.

### 8.3.9 Over/Under Voltage Protection

TPS53125 monitors a resistor divided feedback voltage to detect over and under voltage. If the feedback voltage is higher than 115% of the reference voltage, the OVP comparator output goes high and the circuit latches the high-side MOSFET driver OFF and the low-side MOSFET driver ON.

When the feedback voltage is lower than 70% of the reference voltage, the UVP comparator output goes high and an internal UVP delay counter begins counting. After 30  $\mu$ s, TPS53125 latches OFF both top and bottom MOSFET drivers. This function is enabled approximately  $1.7 \times T_{SS}$  after power-on. The OVP and UVP latch off is reset when EN goes low level.

### 8.3.10 UVLO Protection

TPS53125 has V5FILT under voltage lock out protection (UVLO) that monitors the voltage of V5FILT pin.

When the V5FILT voltage is lower than UVLO threshold voltage, the device is shut off. All output drivers are OFF and output discharge is ON. The UVLO is non-latch protection.

### 8.3.11 Thermal Shutdown

The TPS53125 includes an over temperature protection shut-down feature. If the TPS53125 die temperature exceeds the OTP threshold (typically 150°C), both the high-side and low-side drivers are shut off, the output voltage discharge function is enabled and then the device is shut off until the die temperature drops. Thermal shutdown is a non-latch protection.

## 8.4 Device Functional Modes

The TPS53125 has two operating modes. The TPS53125 is in shut down mode when the EN1 and EN2 pins are low. When the EN1 and EN2 pins is pulled high, the TPS53125 enters the normal operating mode.

## 9 Application and Implementation

### 9.1 Application Information

### 9.2 Typical Application

The TPS53125 is a Dual D-CAP2™ Mode Control Step-Down Controller in a realistic cost-sensitive application. Providing both a low core-type 1.05 V and I/O type 1.8 V output from a loosely regulated 12 V source. Idea applications are: Digital TV Power Supply, Networking Home Pin, Digital Set-Top Box (STB), DVD Player/Recorder, and Gaming Consoles.

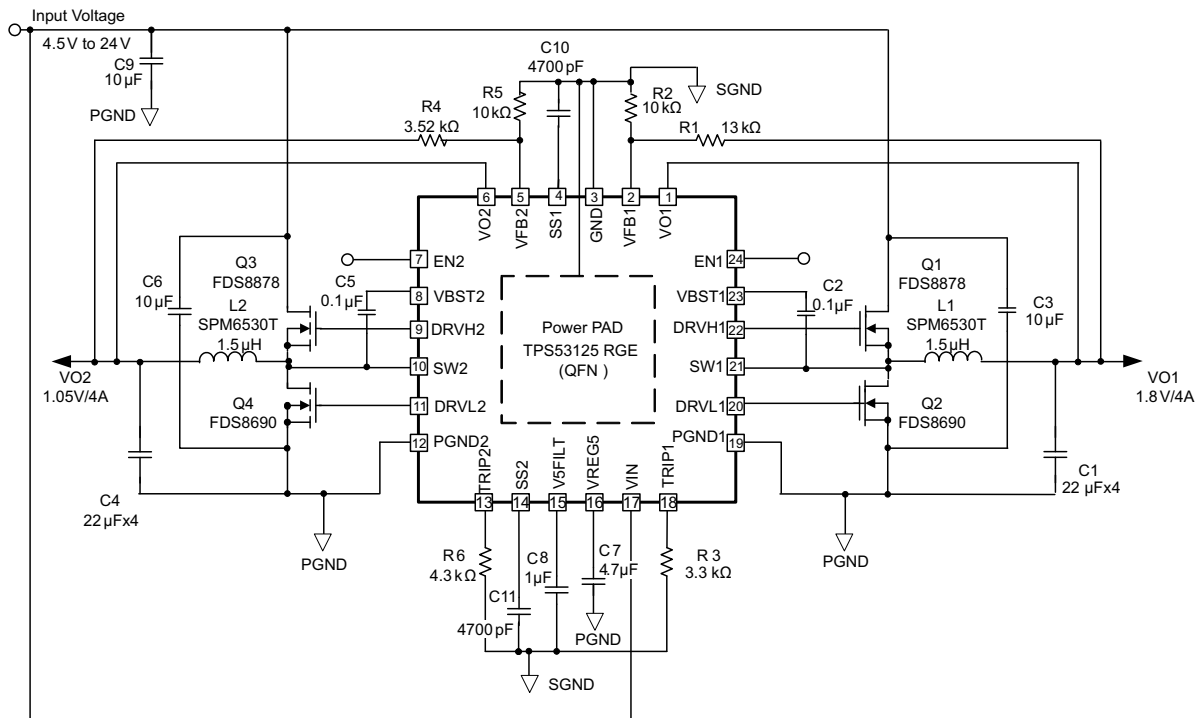


Figure 6. TPS53125 Typical Application Circuit (QFN)

#### 9.2.1 Design Requirements (QFN)

Table 1. Design Parameters

PARAMETERS	EXAMPLE VALUES
Input voltage	12 V
Output voltage	VO1 = 1.8 V, VO2 = 1.05 V

#### 9.2.2 Detailed Design Procedure (QFN)

##### 9.2.2.1 Choose Inductor

The inductance value is selected to provide approximately 30% peak to peak ripple current at maximum load. Larger ripple current increases output ripple voltage, improve S/N ratio and contribute to stable operation.

Equation 3 can be used to calculate L1.

$$L1 = \frac{(V_{IN(MAX)} - V_{O1})}{I_{L1(RIPPLE)} \times f_{SW}} \times \frac{V_{O1}}{V_{IN(MAX)}} = \frac{(V_{IN(MAX)} - V_{O1})}{0.3 \times I_{O1} \times f_{SW}} \times \frac{V_{O1}}{V_{IN(MAX)}} \quad (3)$$

The inductors current ratings needs to support both the RMS (thermal) current and the Peak (saturation) current. The RMS and peak inductor current can be estimated as follows.

$$I_{L1(\text{RIPPLE})} = \frac{(V_{\text{IN}(\text{MAX})} - V_{\text{O}1})}{L1 \times f_{\text{SW}}} \times \frac{V_{\text{O}1}}{V_{\text{IN}(\text{MAX})}} \quad (4)$$

$$I_{L1(\text{PEAK})} = \frac{V_{\text{TRIP}}}{R_{\text{DS}(\text{ON})}} + I_{L1(\text{RIPPLE})} \quad (5)$$

$$I_{L1(\text{RMS})} = \sqrt{I_{\text{O}1}^2 + \frac{1}{12} (I_{L1(\text{RIPPLE})})^2} \quad (6)$$

Note: The calculation above shall serve as a general reference. To further improve transient response, the output inductance could be reduced further. This needs to be considered along with the selection of the output capacitor.

### 9.2.2.2 Choose Output Capacitor

The capacitor value and ESR determines the amount of output voltage ripple and load transient response. It is recommended to use a ceramic output capacitor.

$$C1 = \frac{I_{L1(\text{RIPPLE})}}{8 \times V_{\text{O}1(\text{RIPPLE})}} \times \frac{1}{f_{\text{SW}}} \quad (7)$$

$$C1 = \frac{\Delta I_{\text{load}}^2 \times L1}{2 \times V_{\text{O}1} \times \Delta V_{\text{OS}}} \quad (8)$$

$$C1 = \frac{\Delta I_{\text{load}}^2 \times L1}{2 \times K \times \Delta V_{\text{US}}} \quad (9)$$

Where

$$K = (V_{\text{IN}} - V_{\text{O}1}) \times \frac{T_{\text{on}1}}{T_{\text{on}1} + T_{\text{min}(\text{off})}} \quad (10)$$

Select the capacitance value greater than the largest value calculated from [Equation 7](#), [Equation 8](#) and [Equation 9](#). The capacitance for C1 should be greater than 66 μF.

Where

$\Delta V_{\text{OS}}$  = The allowable amount of overshoot voltage in load transition

$\Delta V_{\text{US}}$  = The allowable amount of undershoot voltage in load transition

$T_{\text{min}(\text{off})}$  = Minimum off time

### 9.2.2.3 Choose Input Capacitor

The TPS53125 requires an input decoupling capacitor and a bulk capacitor is needed depending on the application. A minimum 10-μF high-quality ceramic capacitor is recommended for the input capacitor. The capacitor voltage rating needs to be greater than the maximum input voltage.

### 9.2.2.4 Choose Bootstrap Capacitor

The TPS53125 requires a bootstrap capacitor from SW to VBST to provide the floating supply for the high-side drivers. A minimum 0.1-μF high-quality ceramic capacitor is recommended. The voltage rating should be greater than 10 V.

### 9.2.2.5 Choose VREG5 and V5FILT Capacitor

The TPS53125 requires both the VREG5 regulator and V5FILT input are bypassed. A minimum 4.7-μF high-quality ceramic capacitor must be connected between the VREG5 and GND for proper operation. A minimum 1-μF high-quality ceramic capacitor must be connected between the V5FILT and GND for proper operation. Both of these capacitors' voltage ratings should be greater than 10 V.

### 9.2.2.6 Choose Output Voltage Set Point Resistors

The output voltage is set with a resistor divider from the output voltage node to the VFBx pin. It is recommended to use 1% tolerance or better resistors. Select R2 between 10 kΩ and 100 kΩ and use [Equation 11](#) or [Equation 12](#) to calculate R1.

$$V_{\text{swinj}} = (V_{\text{IN}} - V_{\text{O1}} \times 0.5875) \times \left( \frac{1}{f_{\text{SW}}} \right) \times \left( \frac{V_{\text{O1}}}{V_{\text{IN}}} \right) \times 4975 \quad (11)$$

$$R1 = \left( \frac{V_{\text{O1}}}{V_{\text{FB}} + \frac{V_{\text{FB(RIPPLE)}} + V_{\text{swinj}}}{2}} - 1 \right) \times R2 \quad (12)$$

Where

$V_{\text{FB(RIPPLE)}}$  = Ripple voltage at VFB

$V_{\text{swinj}}$  = Ripple voltage at error comparator

### 9.2.2.7 Choose Over Current Set Point Resistor

$$V_{\text{TRIP}} = \left( I_{\text{OCL}} - \frac{(V_{\text{IN}} - V_{\text{O}})}{2 \times L1 \times f_{\text{SW}}} \times \frac{V_{\text{O}}}{V_{\text{IN}}} \right) \times R_{\text{DS(ON)}} \quad (13)$$

$$V_{\text{TRIP}} = \left( I_{\text{OCL}} - \frac{(V_{\text{IN}} - V_{\text{O}})}{2 \times L1 \times f_{\text{SW}}} \times \frac{V_{\text{O}}}{V_{\text{IN}}} \right) \times R_{\text{DS(ON)}} \quad (14)$$

Where

$R_{\text{DS(ON)}}$  = Low side FET on-resistance

$I_{\text{TRIP(min)}}$  = TRIP pin source current ( 8.5 μA )

$V_{\text{OCLoff}}$  = Minimum over current limit offset voltage (–20 mV)

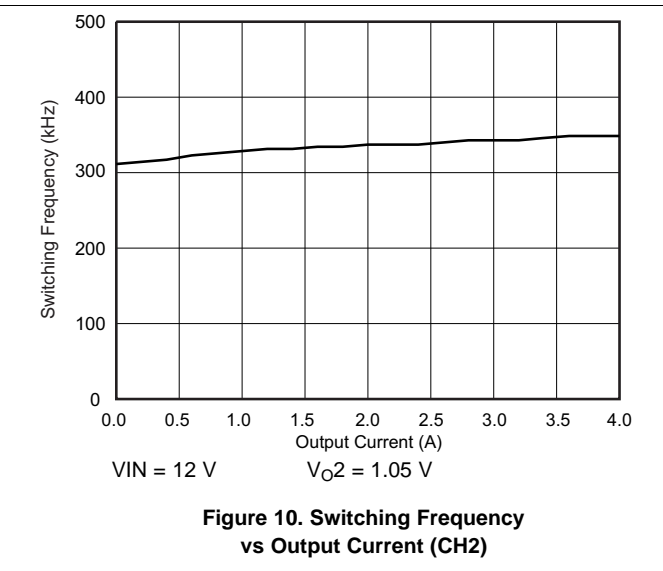
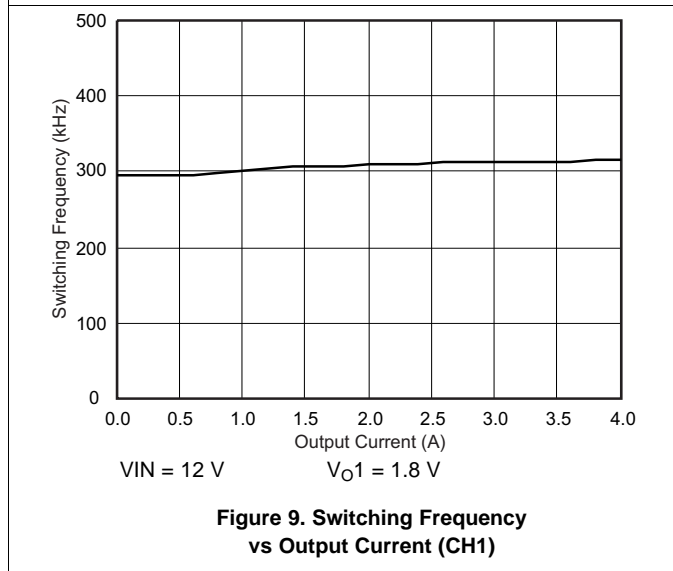
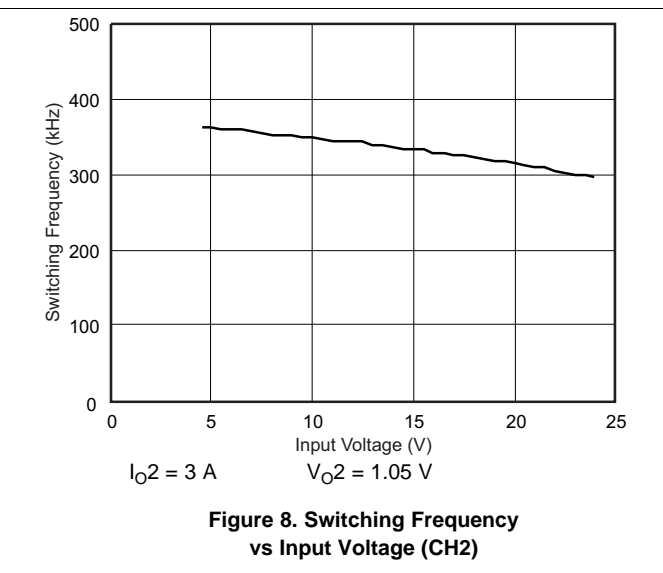
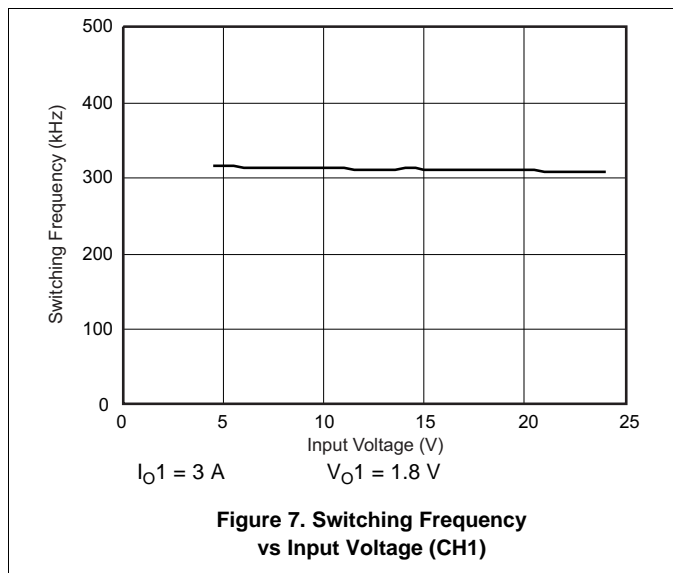
$I_{\text{OCL}}$  = Over current limit

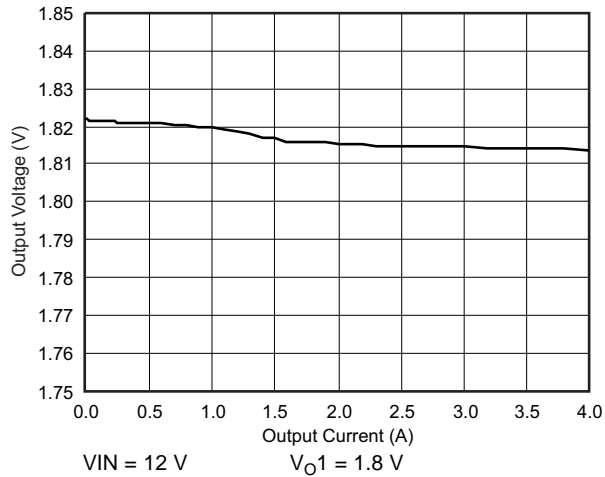
### 9.2.2.8 Choose Soft Start Capacitor

Soft start time equation is as follows.

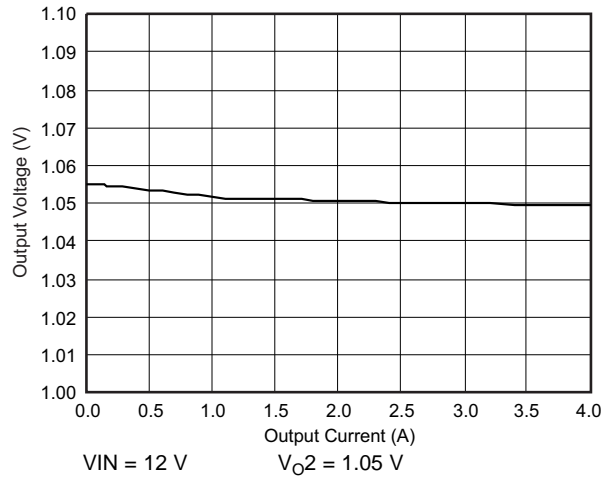
$$C_{\text{SS}} = \frac{T_{\text{SS}} \times I_{\text{SSC}}}{V_{\text{FB}}} \quad (15)$$

9.2.3 Application Curves (QFN)

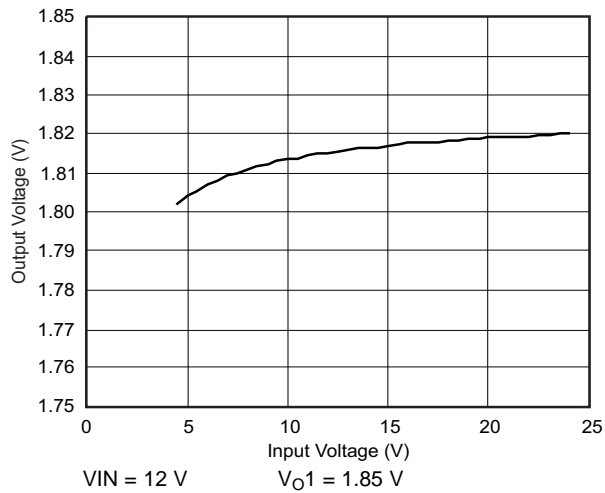




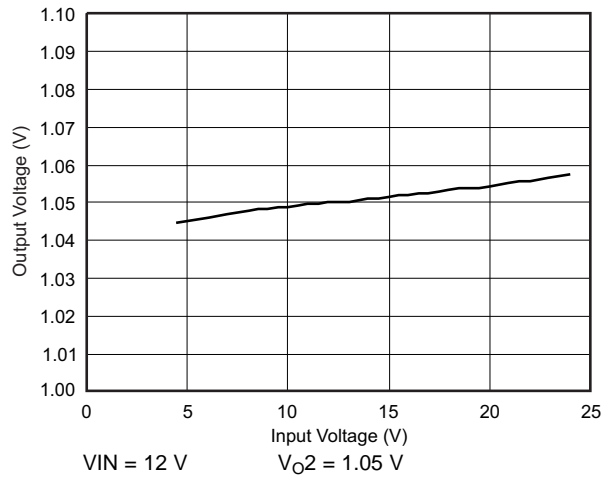
**Figure 11. Output Voltage vs Output Current (CH1)**



**Figure 12. Output Voltage vs Output Current (CH2)**



**Figure 13. Output Voltage vs Input Voltage (CH1)**



**Figure 14. Output Voltage vs Input Voltage (CH2)**

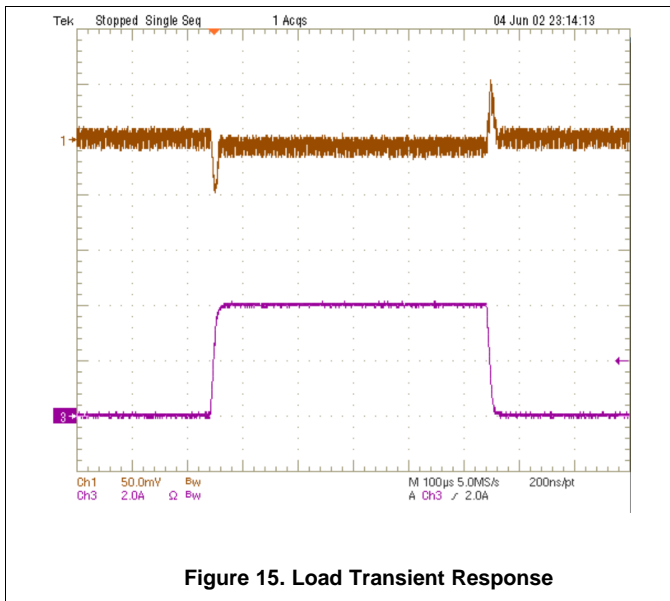


Figure 15. Load Transient Response

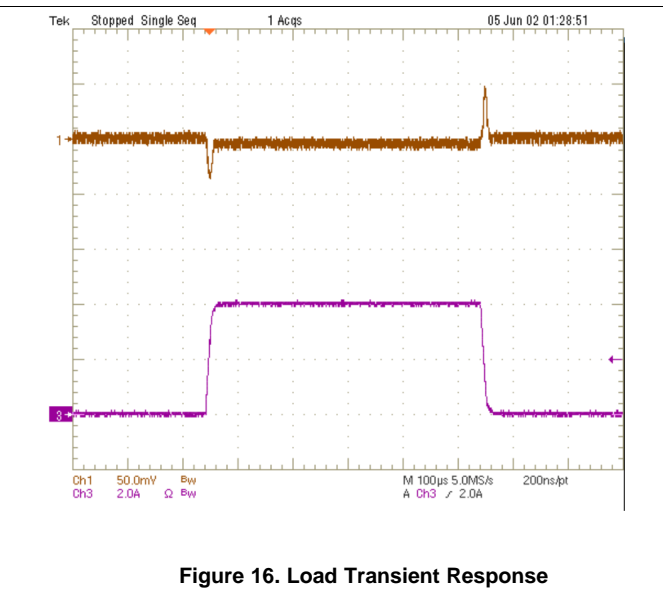


Figure 16. Load Transient Response

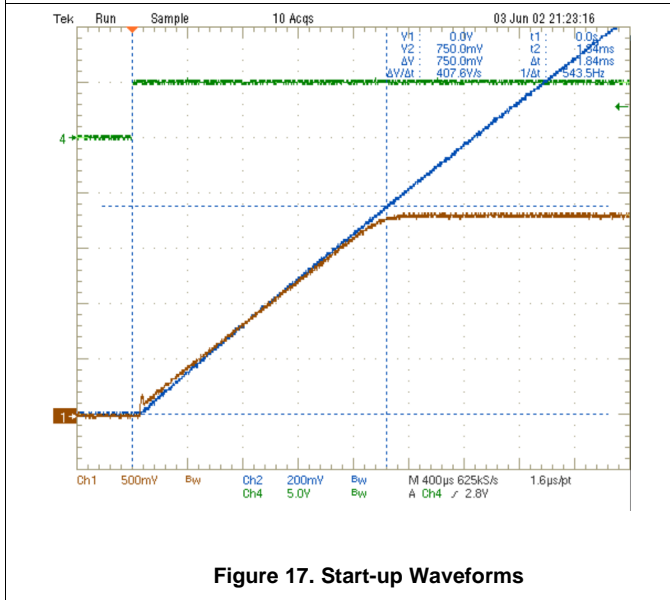


Figure 17. Start-up Waveforms

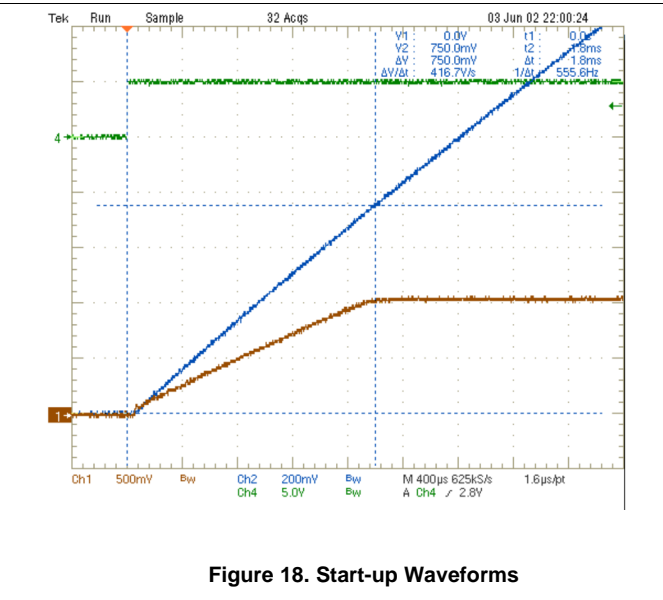


Figure 18. Start-up Waveforms

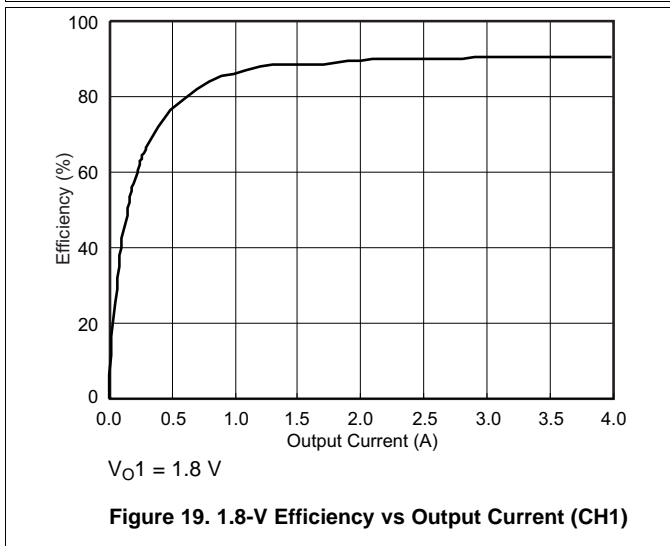


Figure 19. 1.8-V Efficiency vs Output Current (CH1)

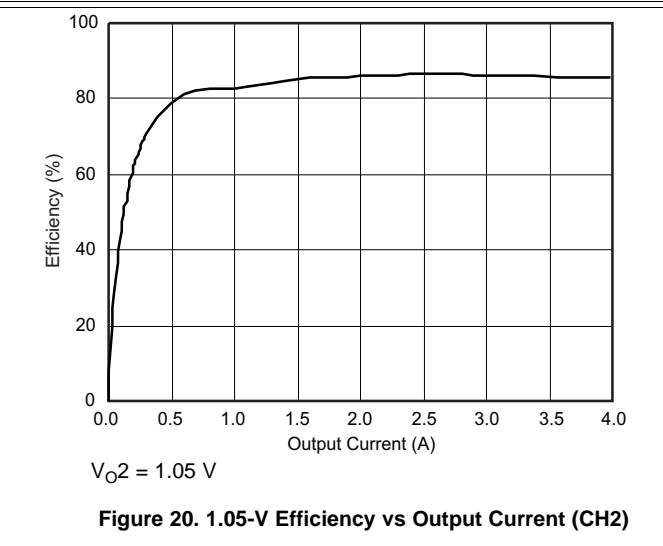
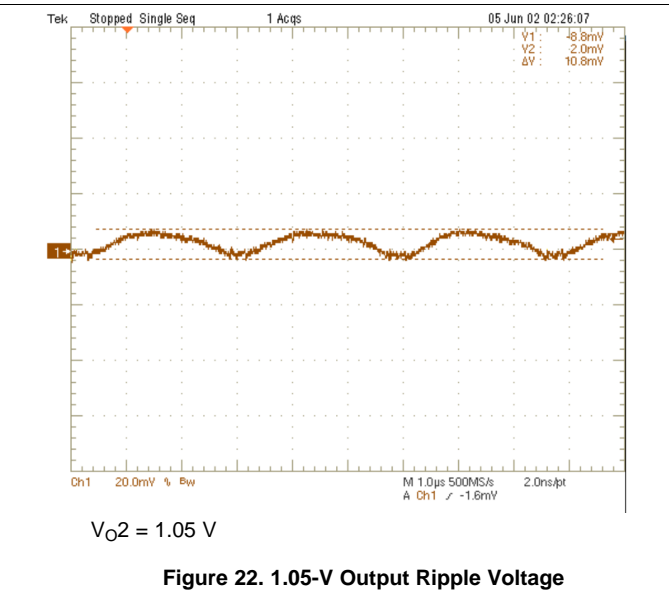
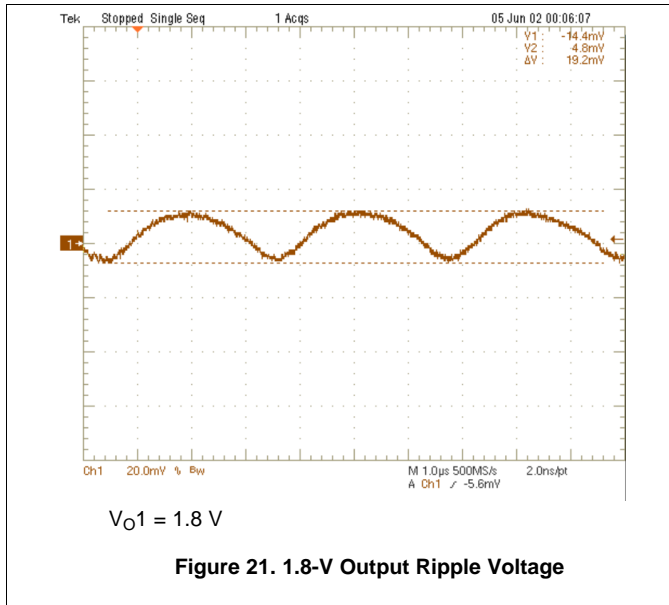


Figure 20. 1.05-V Efficiency vs Output Current (CH2)



### 9.3 Typical Application Circuit, TSSOP

The TPS53125 is a Dual D-CAP2™ Mode Control Step-Down Controller in a realistic cost-sensitive application. Providing both a low core-type 1.05 V and I/O type 1.8 V output from a loosely regulated 12 V source.

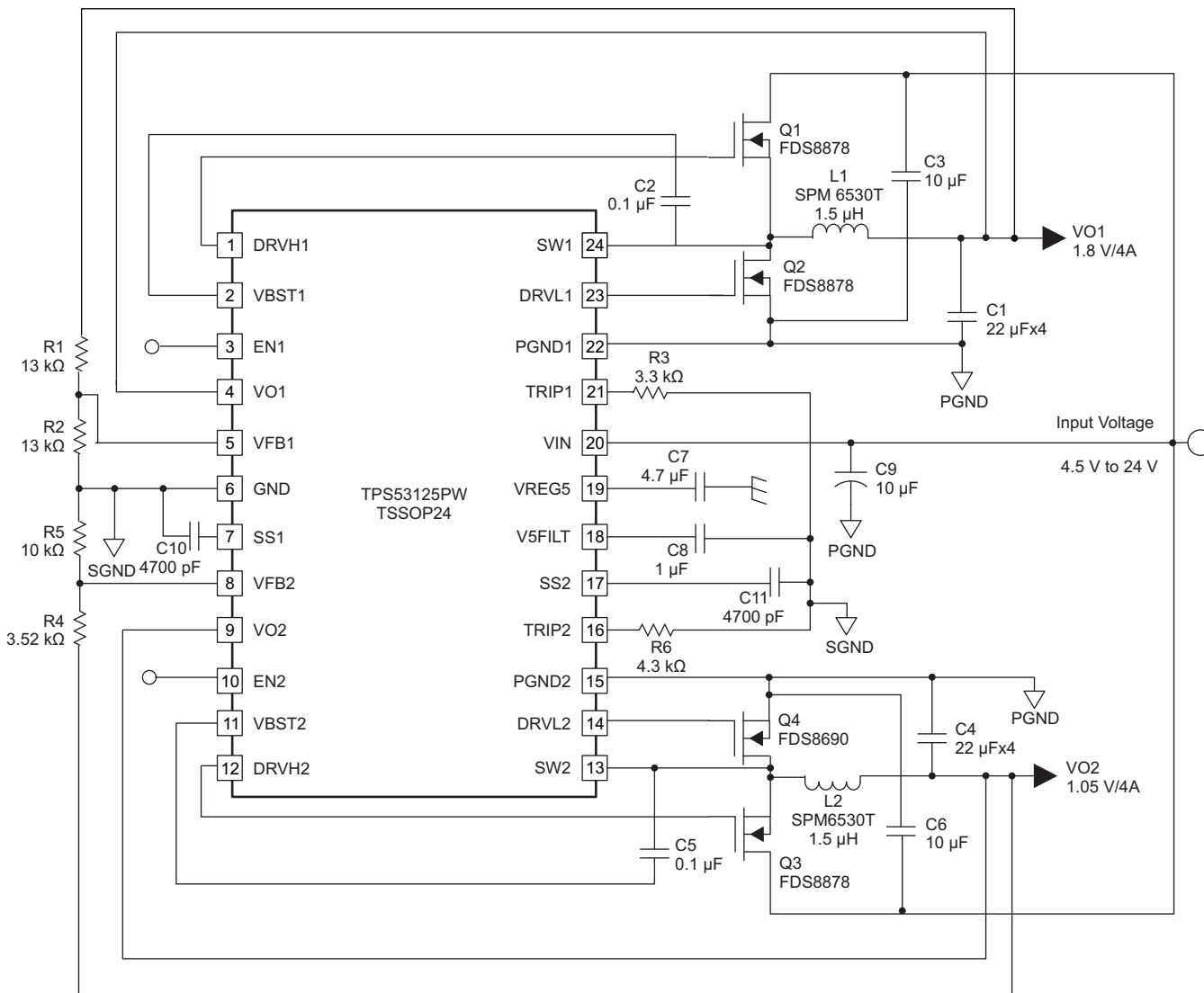


Figure 23. TSSOP

#### 9.3.1 Design Requirements

For the Design Requirements, refer to [Design Requirements \(QFN\)](#).

#### 9.3.2 Detailed Design Procedure

For the Detailed Design Procedure, refer to [Detailed Design Procedure \(QFN\)](#).

#### 9.3.3 Application Curves

For Application Curves, refer to [Application Curves \(QFN\)](#).

## 10 Power Supply Recommendations

The devices are designed to operate from an input voltage supply range between 4.5 V and 24 V. This input supply must be well regulated. If the input supply is located more than a few inches from the TPS53125 device additional 0.1  $\mu$ F ceramic capacitance may be required in addition to the ceramic bypass capacitors, 10  $\mu$ F.

## 11 Layout

### 11.1 Layout Suggestions

- Keep the input switching current loop as small as possible. (VIN ≥ C3 ≥ PNGD ≥ Sync FET ≥ SW ≥ Control FET)
- Place the input capacitor (C3) close to the top switching FET. The output current loop should also be kept as small as possible.
- Keep the SW node as physically small and short as possible as to minimize parasitic capacitance and inductance and to minimize radiated emissions. Kelvin connections should be brought from the output to the feedback terminal (FBx) of the device.
- Keep analog and non-switching components away from switching components.
- Make a single point connection from the signal ground to power ground.(1)
- Do not allow switching current to flow under the device.
- DRVH and DRVL line should not run close to SW node or minimize it. (2)
- GND terminals for capacitors of SSx and V5FILT and resistors of feedback and TRIPx should be connected to SGND. (3)
- GND terminals for capacitors of VREG5 and VIN should be connected to PGND. (4)
- Signal lines should not run under/near Output Inductor or minimize it. (5)

## 11.2 Layout Example

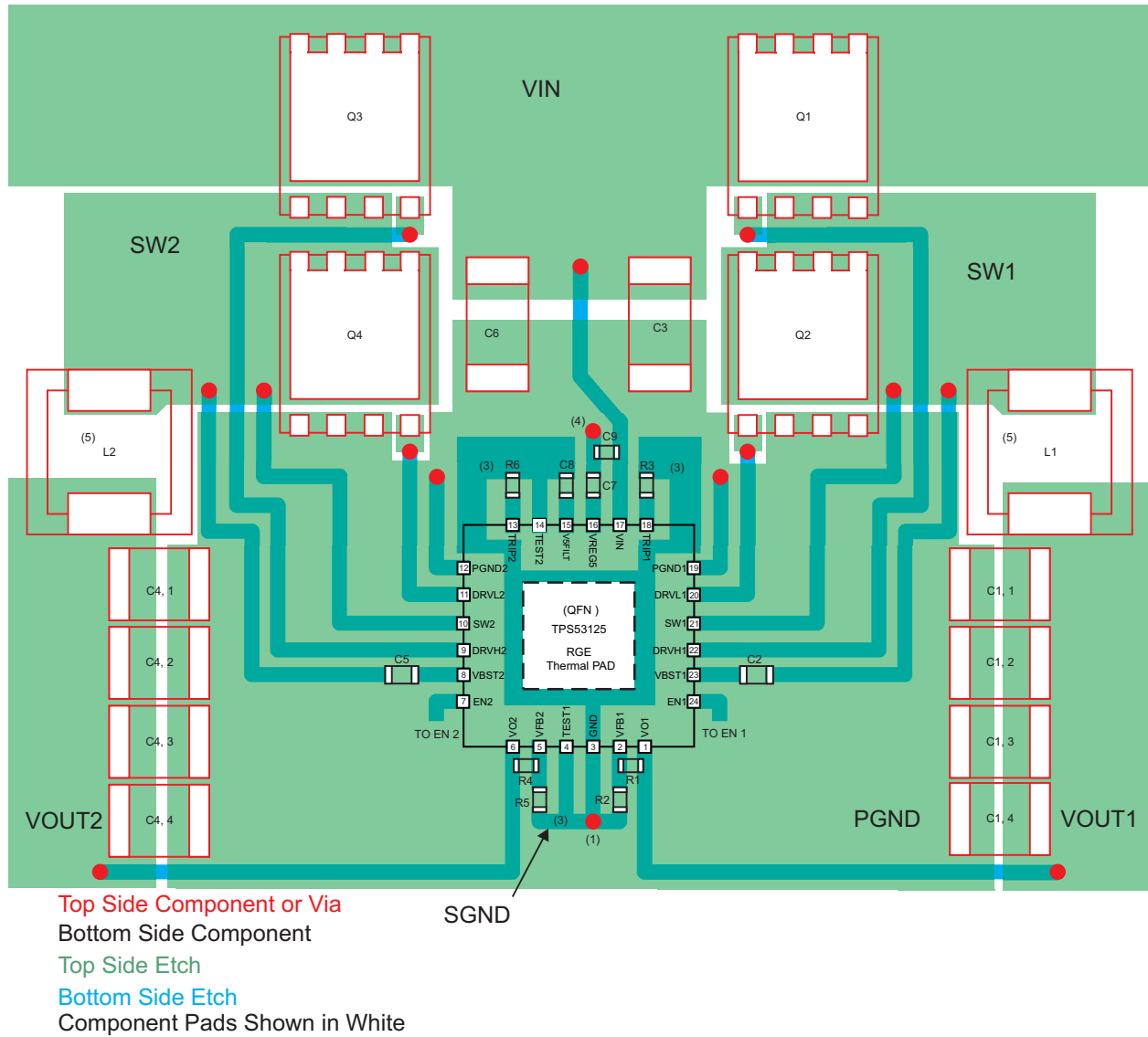


Figure 24.

## 12 Device and Documentation Support

### 12.1 Trademarks

D-CAP2 is a trademark of Texas Instruments.  
All other trademarks are the property of their respective owners.

### 12.2 Electrostatic Discharge Caution



These devices have limited built-in ESD protection. The leads should be shorted together or the device placed in conductive foam during storage or handling to prevent electrostatic damage to the MOS gates.

### 12.3 Glossary

[SLYZ022](#) — *TI Glossary*.

This glossary lists and explains terms, acronyms, and definitions.

## 13 Mechanical, Packaging, and Orderable Information

The following pages include mechanical, packaging, and orderable information. This information is the most current data available for the designated devices. This data is subject to change without notice and revision of this document. For browser-based versions of this data sheet, refer to the left-hand navigation.

**PACKAGING INFORMATION**

Orderable Device	Status (1)	Package Type	Package Drawing	Pins	Package Qty	Eco Plan (2)	Lead/Ball Finish (6)	MSL Peak Temp (3)	Op Temp (°C)	Device Marking (4/5)	Samples
TPS53125PW	ACTIVE	TSSOP	PW	24	60	Green (RoHS & no Sb/Br)	CU NIPDAU	Level-1-260C-UNLIM	-40 to 85	TPS53125	<a href="#">Samples</a>
TPS53125PWR	ACTIVE	TSSOP	PW	24	2000	Green (RoHS & no Sb/Br)	CU NIPDAU	Level-1-260C-UNLIM	-40 to 85	TPS53125	<a href="#">Samples</a>
TPS53125RGER	ACTIVE	VQFN	RGE	24	3000	Green (RoHS & no Sb/Br)	CU NIPDAU	Level-2-260C-1 YEAR	-40 to 85	TPS 53125	<a href="#">Samples</a>
TPS53125RGET	ACTIVE	VQFN	RGE	24	250	Green (RoHS & no Sb/Br)	CU NIPDAU	Level-2-260C-1 YEAR	-40 to 85	TPS 53125	<a href="#">Samples</a>

(1) The marketing status values are defined as follows:

**ACTIVE:** Product device recommended for new designs.

**LIFEBUY:** TI has announced that the device will be discontinued, and a lifetime-buy period is in effect.

**NRND:** Not recommended for new designs. Device is in production to support existing customers, but TI does not recommend using this part in a new design.

**PREVIEW:** Device has been announced but is not in production. Samples may or may not be available.

**OBSOLETE:** TI has discontinued the production of the device.

(2) **RoHS:** TI defines "RoHS" to mean semiconductor products that are compliant with the current EU RoHS requirements for all 10 RoHS substances, including the requirement that RoHS substance do not exceed 0.1% by weight in homogeneous materials. Where designed to be soldered at high temperatures, "RoHS" products are suitable for use in specified lead-free processes. TI may reference these types of products as "Pb-Free".

**RoHS Exempt:** TI defines "RoHS Exempt" to mean products that contain lead but are compliant with EU RoHS pursuant to a specific EU RoHS exemption.

**Green:** TI defines "Green" to mean the content of Chlorine (Cl) and Bromine (Br) based flame retardants meet JS709B low halogen requirements of <=1000ppm threshold. Antimony trioxide based flame retardants must also meet the <=1000ppm threshold requirement.

(3) MSL, Peak Temp. - The Moisture Sensitivity Level rating according to the JEDEC industry standard classifications, and peak solder temperature.

(4) There may be additional marking, which relates to the logo, the lot trace code information, or the environmental category on the device.

(5) Multiple Device Markings will be inside parentheses. Only one Device Marking contained in parentheses and separated by a "-" will appear on a device. If a line is indented then it is a continuation of the previous line and the two combined represent the entire Device Marking for that device.

(6) Lead/Ball Finish - Orderable Devices may have multiple material finish options. Finish options are separated by a vertical ruled line. Lead/Ball Finish values may wrap to two lines if the finish value exceeds the maximum column width.

**Important Information and Disclaimer:** The information provided on this page represents TI's knowledge and belief as of the date that it is provided. TI bases its knowledge and belief on information provided by third parties, and makes no representation or warranty as to the accuracy of such information. Efforts are underway to better integrate information from third parties. TI has taken and

---

continues to take reasonable steps to provide representative and accurate information but may not have conducted destructive testing or chemical analysis on incoming materials and chemicals. TI and TI suppliers consider certain information to be proprietary, and thus CAS numbers and other limited information may not be available for release.

In no event shall TI's liability arising out of such information exceed the total purchase price of the TI part(s) at issue in this document sold by TI to Customer on an annual basis.

**TAPE AND REEL INFORMATION**

**QUADRANT ASSIGNMENTS FOR PIN 1 ORIENTATION IN TAPE**


\*All dimensions are nominal

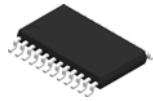
Device	Package Type	Package Drawing	Pins	SPQ	Reel Diameter (mm)	Reel Width W1 (mm)	A0 (mm)	B0 (mm)	K0 (mm)	P1 (mm)	W (mm)	Pin1 Quadrant
TPS53125PWR	TSSOP	PW	24	2000	330.0	16.4	6.95	8.3	1.6	8.0	16.0	Q1
TPS53125RGER	VQFN	RGE	24	3000	330.0	12.4	4.25	4.25	1.15	8.0	12.0	Q2
TPS53125RGET	VQFN	RGE	24	250	180.0	12.4	4.25	4.25	1.15	8.0	12.0	Q2

**TAPE AND REEL BOX DIMENSIONS**


\*All dimensions are nominal

Device	Package Type	Package Drawing	Pins	SPQ	Length (mm)	Width (mm)	Height (mm)
TPS53125PWR	TSSOP	PW	24	2000	367.0	367.0	38.0
TPS53125RGER	VQFN	RGE	24	3000	367.0	367.0	35.0
TPS53125RGET	VQFN	RGE	24	250	210.0	185.0	35.0

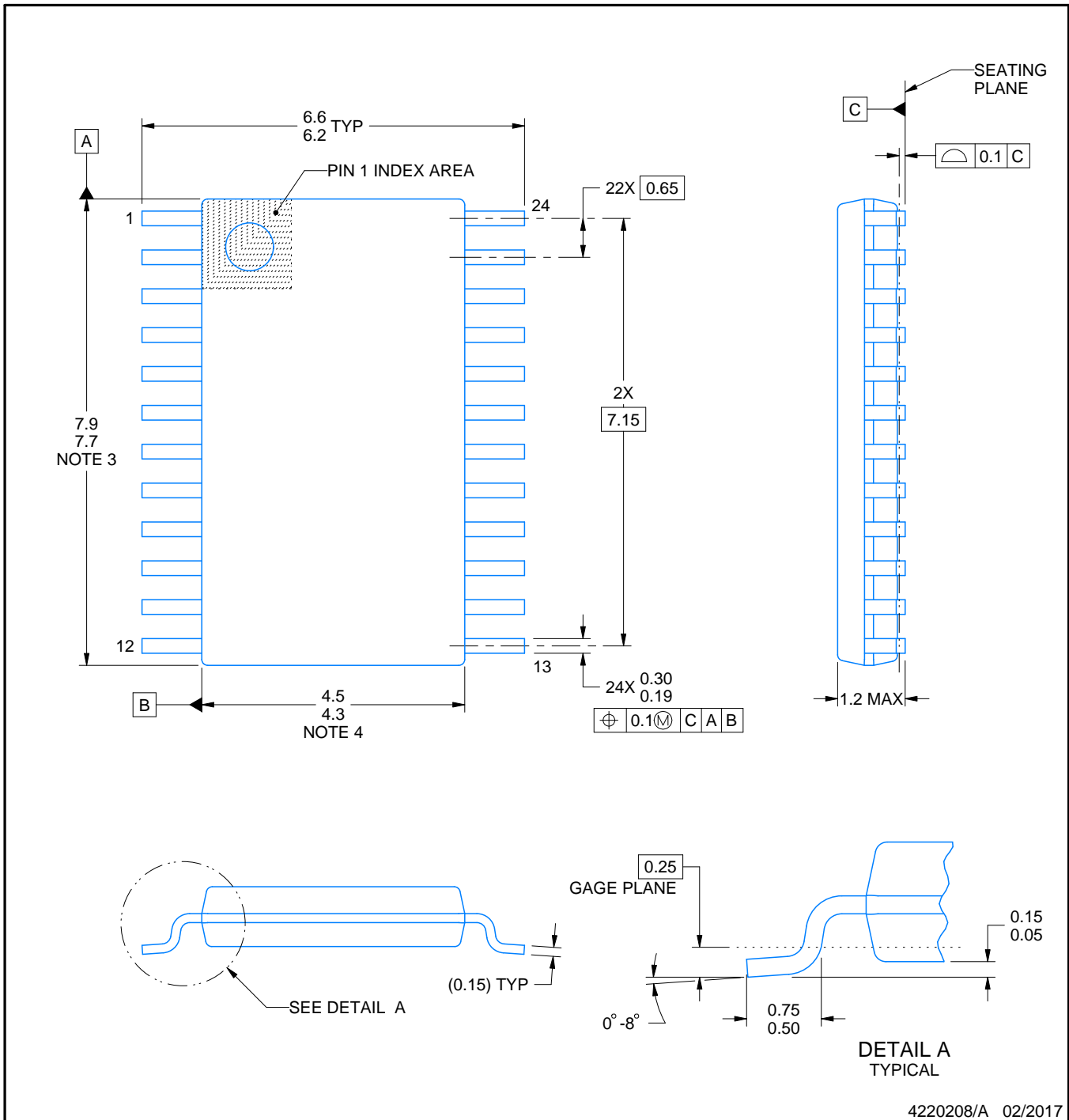
# PW0024A



# PACKAGE OUTLINE

## TSSOP - 1.2 mm max height

SMALL OUTLINE PACKAGE



4220208/A 02/2017

### NOTES:

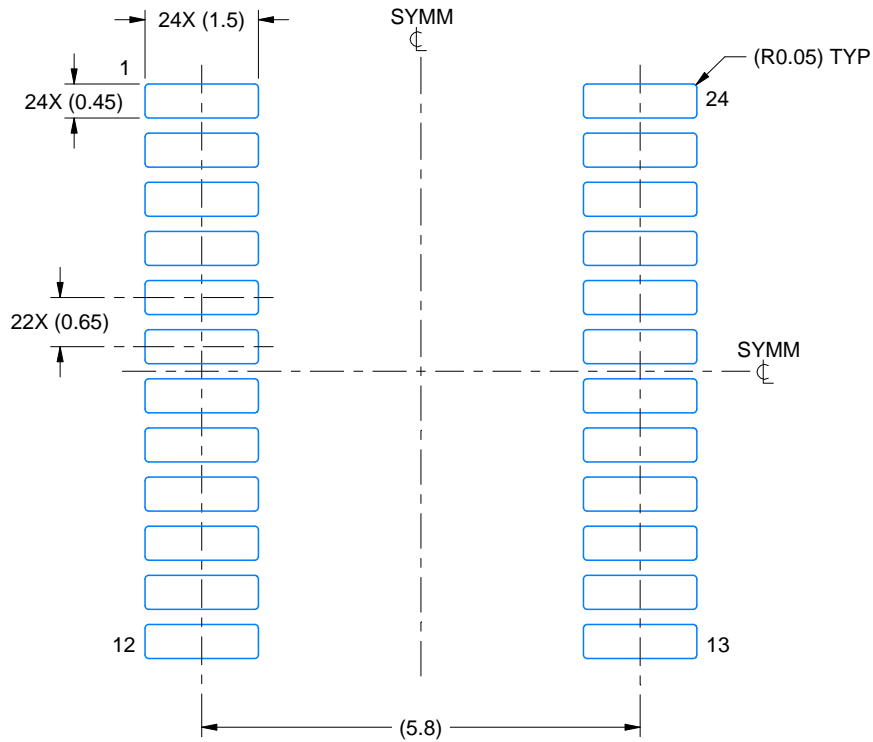
1. All linear dimensions are in millimeters. Any dimensions in parenthesis are for reference only. Dimensioning and tolerancing per ASME Y14.5M.
2. This drawing is subject to change without notice.
3. This dimension does not include mold flash, protrusions, or gate burrs. Mold flash, protrusions, or gate burrs shall not exceed 0.15 mm per side.
4. This dimension does not include interlead flash. Interlead flash shall not exceed 0.25 mm per side.
5. Reference JEDEC registration MO-153.

# EXAMPLE BOARD LAYOUT

PW0024A

TSSOP - 1.2 mm max height

SMALL OUTLINE PACKAGE



LAND PATTERN EXAMPLE  
EXPOSED METAL SHOWN  
SCALE: 10X



SOLDER MASK DETAILS

4220208/A 02/2017

NOTES: (continued)

- 6. Publication IPC-7351 may have alternate designs.
- 7. Solder mask tolerances between and around signal pads can vary based on board fabrication site.

# EXAMPLE STENCIL DESIGN

PW0024A

TSSOP - 1.2 mm max height

SMALL OUTLINE PACKAGE



NOTES: (continued)

8. Laser cutting apertures with trapezoidal walls and rounded corners may offer better paste release. IPC-7525 may have alternate design recommendations.
9. Board assembly site may have different recommendations for stencil design.

**RGE 24**

**GENERIC PACKAGE VIEW**

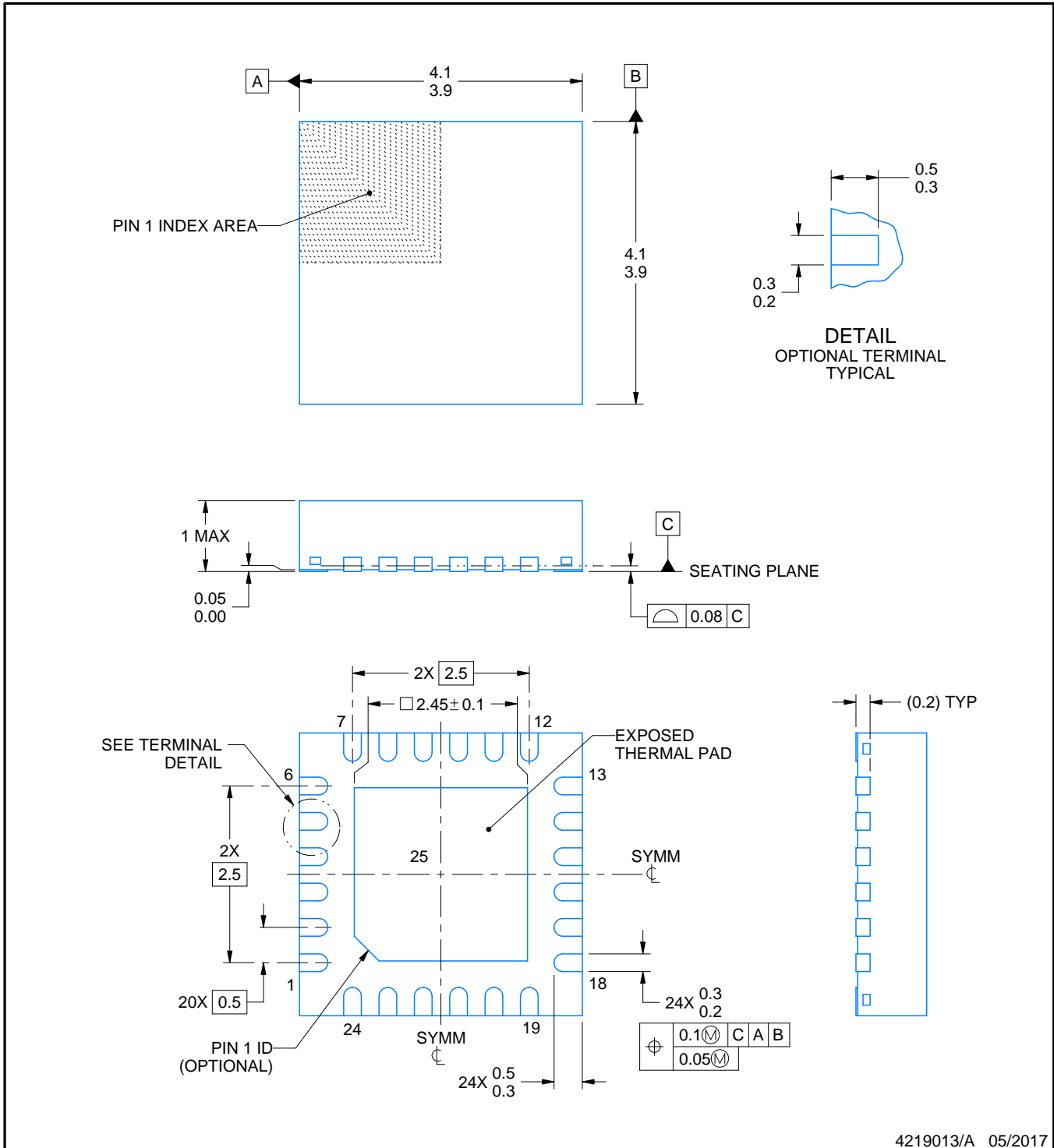
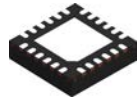
**VQFN - 1 mm max height**

PLASTIC QUAD FLATPACK - NO LEAD



Images above are just a representation of the package family, actual package may vary.  
Refer to the product data sheet for package details.

4204104/H



4219013/A 05/2017

NOTES:

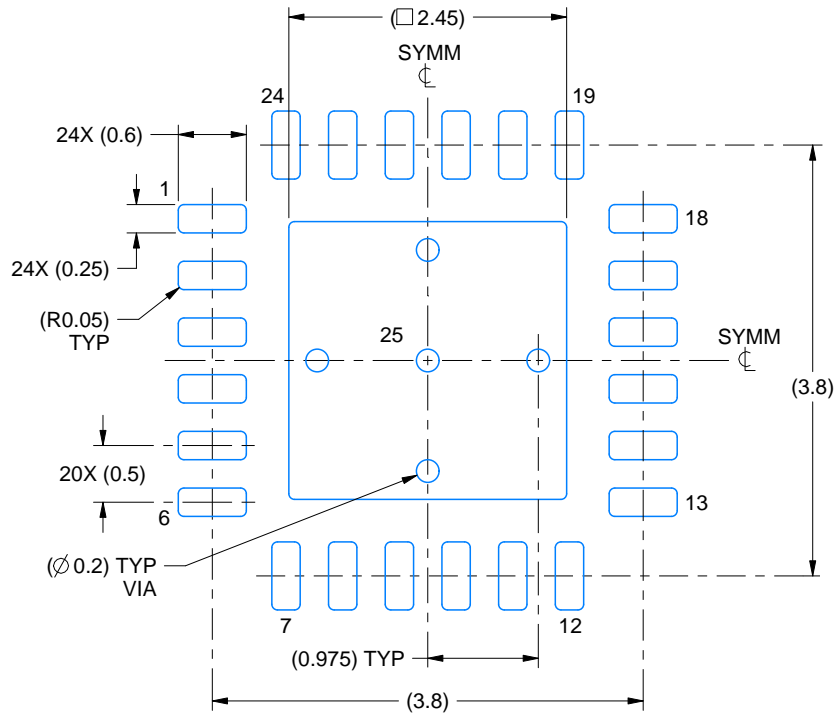
1. All linear dimensions are in millimeters. Any dimensions in parenthesis are for reference only. Dimensioning and tolerancing per ASME Y14.5M.
2. This drawing is subject to change without notice.
3. The package thermal pad must be soldered to the printed circuit board for thermal and mechanical performance.

# EXAMPLE BOARD LAYOUT

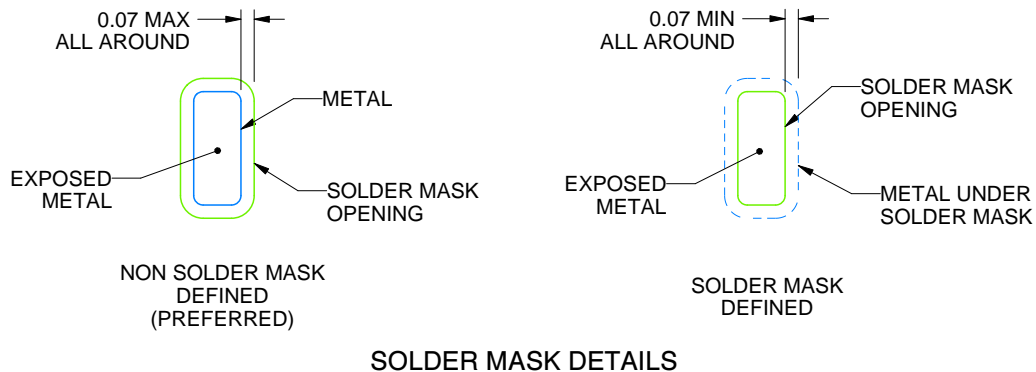
RGE0024B

VQFN - 1 mm max height

PLASTIC QUAD FLATPACK - NO LEAD



LAND PATTERN EXAMPLE  
EXPOSED METAL SHOWN  
SCALE:15X



SOLDER MASK DETAILS

4219013/A 05/2017

NOTES: (continued)

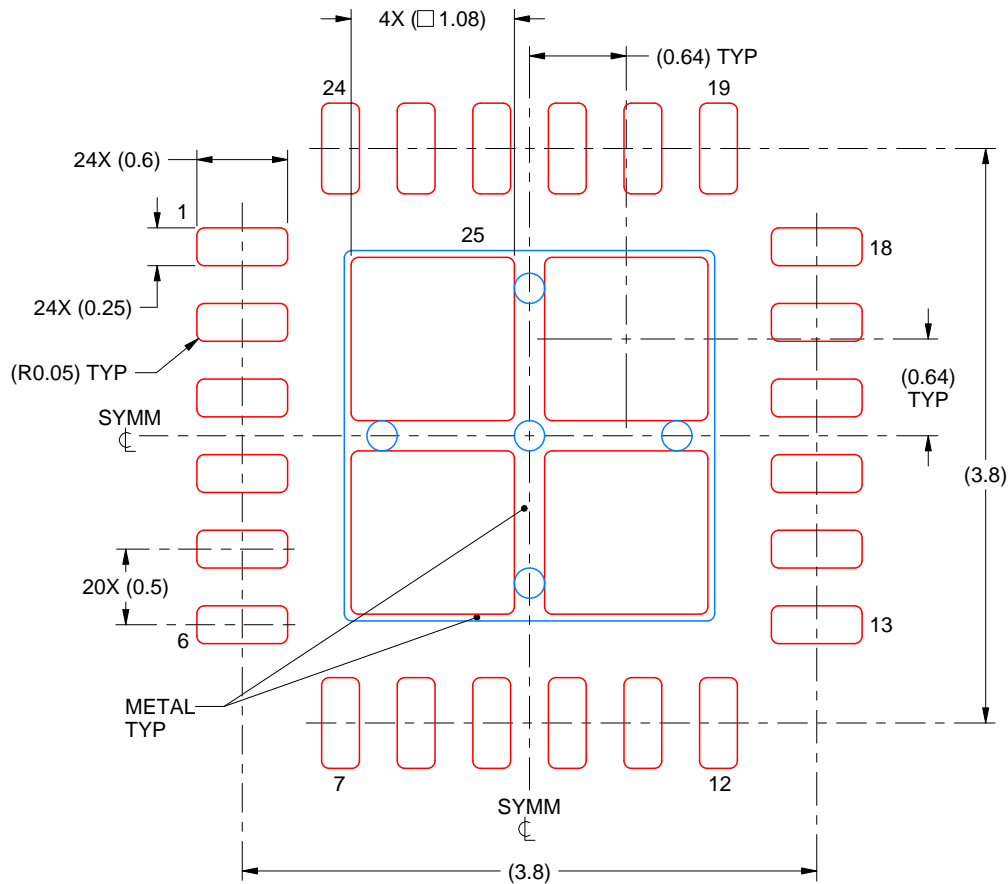
4. This package is designed to be soldered to a thermal pad on the board. For more information, see Texas Instruments literature number SLUA271 ([www.ti.com/lit/sluea271](http://www.ti.com/lit/sluea271)).
5. Vias are optional depending on application, refer to device data sheet. If any vias are implemented, refer to their locations shown on this view. It is recommended that vias under paste be filled, plugged or tented.

# EXAMPLE STENCIL DESIGN

RGE0024B

VQFN - 1 mm max height

PLASTIC QUAD FLATPACK - NO LEAD



SOLDER PASTE EXAMPLE  
BASED ON 0.125 mm THICK STENCIL

EXPOSED PAD 25  
78% PRINTED SOLDER COVERAGE BY AREA UNDER PACKAGE  
SCALE:20X

4219013/A 05/2017

NOTES: (continued)

6. Laser cutting apertures with trapezoidal walls and rounded corners may offer better paste release. IPC-7525 may have alternate design recommendations.

## IMPORTANT NOTICE AND DISCLAIMER

TI PROVIDES TECHNICAL AND RELIABILITY DATA (INCLUDING DATASHEETS), DESIGN RESOURCES (INCLUDING REFERENCE DESIGNS), APPLICATION OR OTHER DESIGN ADVICE, WEB TOOLS, SAFETY INFORMATION, AND OTHER RESOURCES "AS IS" AND WITH ALL FAULTS, AND DISCLAIMS ALL WARRANTIES, EXPRESS AND IMPLIED, INCLUDING WITHOUT LIMITATION ANY IMPLIED WARRANTIES OF MERCHANTABILITY, FITNESS FOR A PARTICULAR PURPOSE OR NON-INFRINGEMENT OF THIRD PARTY INTELLECTUAL PROPERTY RIGHTS.

These resources are intended for skilled developers designing with TI products. You are solely responsible for (1) selecting the appropriate TI products for your application, (2) designing, validating and testing your application, and (3) ensuring your application meets applicable standards, and any other safety, security, or other requirements. These resources are subject to change without notice. TI grants you permission to use these resources only for development of an application that uses the TI products described in the resource. Other reproduction and display of these resources is prohibited. No license is granted to any other TI intellectual property right or to any third party intellectual property right. TI disclaims responsibility for, and you will fully indemnify TI and its representatives against, any claims, damages, costs, losses, and liabilities arising out of your use of these resources.

TI's products are provided subject to TI's Terms of Sale ([www.ti.com/legal/termsofsale.html](http://www.ti.com/legal/termsofsale.html)) or other applicable terms available either on [ti.com](http://ti.com) or provided in conjunction with such TI products. TI's provision of these resources does not expand or otherwise alter TI's applicable warranties or warranty disclaimers for TI products.

Mailing Address: Texas Instruments, Post Office Box 655303, Dallas, Texas 75265  
Copyright © 2019, Texas Instruments Incorporated

## Looking for pricing, stock, or lifecycle information?

Click below to explore more details on WIN SOURCE:

 [View TPS53125EVM-599](#) on WIN SOURCE

 [Texas Instruments](#) Information

## Optimize Your Supply Chain with WIN SOURCE Solutions

-  Global Sourcing Solution
-  Obsolete Management
-  Cost Control Management
-  Shortage Management
-  Alternative Solution
-  Excess Inventory Management