



**THE DATASHEET OF
PR5331C3HN/C350,51**





PR533

USB NFC integrated reader solution

Rev. 3.6 — 27 October 2014
206436

Product short data sheet
COMPANY PUBLIC

1. General description

The PR5331C3HN is a highly integrated transceiver module for contactless reader/writer communication at 13.56 MHz.

A dedicated ROM code is implemented to handle different RF protocols by an integrated microcontroller. The system host controller communicates with the PR5331C3HN by using the USB or the HSU link.

The protocol between the host controller and the PR5331C3HN, on top of this physical link is the CCID protocol.

1.1 RF protocols

PR5331C3HN supports the PCD mode for FeliCa (212 kbps and 424 kbps), ISO/IEC14443 Type A and B (from 106 kbps to 848 kbps), MIFARE (106 kbps), B' cards (106 kbps), picoPass tag (106 kbps) and Innovision Jewel cards (106 kbps)

The Initiator passive mode (from 106 kbps to 424 kbps) can be supported through the PC/SC transparent mode.

1.2 Interfaces

The PR5331C3HN supports a USB 2.0 full speed interface (bus powered or host powered mode).

Alternatively to the USB interface, a High Speed UART (from 9600b up to 1.2 Mb) can be used to connect the PR533 to a host.

The PR5331C3HN has also a master I²C-bus interface that allows to connect one of the following peripherals:

- An external EEPROM: in this case the PR5331C3HN is configured as master and is able to communicate with external EEPROM (address A0h) which can store configuration data like PID, UID and RF parameters. When a USB host interface is used, these parameters are retrieved from the EEPROM at startup of the device
- A TDA8029 contact smart card reader

1.3 Standards compliancy

PR5331C3HN offers commands in order for applications to be compliant with “EMV Contactless Communication Protocol Specification V2.0.1”.

PR5331C3HN supports RF protocols ISO/IEC 14443A and B such as compliancy with Smart eID standard can be achieved at application level.



Support of USB 2.0 full speed, interoperable with USB 3.0 hubs.

The PR533C3HN in PCD mode is compliant with EMV contactless specification V2.0.1.

1.4 Supported operating systems

- Microsoft Windows 2000
- Microsoft Windows XP (32 and 64 bits)
- Microsoft Windows 2003 Server (32 and 64 bits)
- Microsoft Windows 2008 Server (32 and 64 bits)
- Microsoft Windows Vista (32 and 64 bits)
- Microsoft Windows 7 (32 and 64 bits)

The PR533 is supported by the following OS through the PCSC-Lite driver:

- GNU/Linux using libusb 1.0.x and later
- Mac OS Leopard (1.5.6 and newer)
- Mac OS Snow Leopard (1.6.X)
- Solaris
- FreeBSD

2. Features and benefits

- USB 2.0 full speed host interface and CCID protocol support
- Integrated microcontroller implements high-level RF protocols
- Buffered output drivers to connect an antenna with minimum number of external components
- Integrated RF level detector
- Integrated data mode detector
- Supports ISO/IEC 14443A Reader/Writer mode up to 848 kbit/s
- Supports ISO/IEC 14443B Reader/Writer mode up to 848 kbit/s
- Supports contactless communication according to the FeliCa protocol at 212 kbit/s and 424 kbit/s
- Supports MIFARE encryption
- Typical operating distance in Read/Write mode for communication to ISO/IEC 14443A/MIFARE, ISO/IEC 14443B or FeliCa cards up to 50 mm depending on antenna size and tuning
- I²C-bus master interface allows to connect an external I²C EEPROM for configuration data storage or to control a TDA8029 contact smart card reader
- Low-power modes
 - ◆ Hard power-down mode
 - ◆ Soft power-down mode
- Only one external oscillator required (27.12 MHz Crystal oscillator)
- Power modes
 - ◆ USB bus power mode
 - ◆ 2.5 V to 3.6 V power supply operating range in non-USB bus power mode

- Dedicated I/O ports for external device control

3. Quick reference data

Table 1. Quick reference data

Symbol	Parameter	Conditions	Min	Typ	Max	Unit
V _{BUS}	bus supply voltage		4.02	5	5.25	V
		(non-USB mode); V _{BUS} = V _{DDD} ; V _{SSD} = 0 V	2.5	3.3	3.6	V
V _{DDA}	analog supply voltage	V _{DDA} = V _{DDD} = V _{DD(TVDD)} =	[1] 2.5	3.3	3.6	V
V _{DDD}	digital supply voltage	V _{DD(PVDD)} ; V _{SSA} = V _{SSD} =	[1] 2.5	3.3	3.6	V
V _{DD(TVDD)}	TVDD supply voltage	V _{SS(PVSS)} = V _{SS(TVSS)} = 0 V	[1] 2.5	3.3	3.6	V
V _{DD(PVDD)}	PVDD supply voltage		1.6	-	3.6	V
V _{DD(SVDD)}	SVDD supply voltage	V _{SSA} = V _{SSD} = V _{SS(PVSS)} = V _{SS(TVSS)} = 0 V; reserved for future use	V _{DDD} - 0.1	-	V _{DDD}	V
I _{BUS}	bus supply current	maximum load current (USB mode); measured on V _{BUS}			150	mA
		maximum inrush current lim- itation; at power-up (curlimoff = 0)			100	mA
I _{pd}	power-down current	V _{DDA} = V _{DDD} = V _{DD(TVDD)} = V _{DD(PVDD)} = 3 V; not powered from USB				
		hard power-down; RF level detector off			10	μA
		soft power-down; RF level detector on			30	μA
I _{CCSL}	suspended low-power device supply current	RF level detector on, (with- out resistor on DP/DM)	-	-	250	μA
I _{DDD}	digital supply current	RF level detector on, V _{DD(SVDD)} switch off	[1] -	15	-	mA
I _{DD(SVDD)}	SVDD supply current	V _{DDS} = 3 V	-	-	30	mA
I _{DDA}	analog supply current	RF level detector on	-	6	-	mA
I _{DD(TVDD)}	TVDD supply current	during RF transmission; V _{DD(TVDD)} = 3 V	-	60	100	mA
P _{tot}	total power dissipation	T _{amb} = -30 to +85 °C	-	-	0.55	W
T _{amb}	ambient temperature		-30	-	+85	°C

[1] V_{DDD}, V_{DDA} and V_{DD(TVDD)} must always be at the same supply voltage.

4. Ordering information

Table 2. Ordering information

Type number	Package		Version
	Name	Description	
PR5331C3HN/C360 ^{[1][2][3]}	HVQFN40	plastic thermal enhanced very thin quad flat package; no leads; 40 terminals; body 6 × 6 × 0.85 mm	SOT618-1
PR5331C3HN/C370 ^{[1][2][3]}			

- [1] 60 or 70 refers to the ROM code version described in the User Manual. For differences of romcode versions refer to the release note of the product.
- [2] Refer to [Section 14.4 “Licenses”](#).
- [3] MSL 2 (Moisture Sensitivity Level).

5. Block diagram

The following block diagram describes hardware blocks controlled by PR5331C3HN firmware or which can be accessible for data transaction by a host baseband.

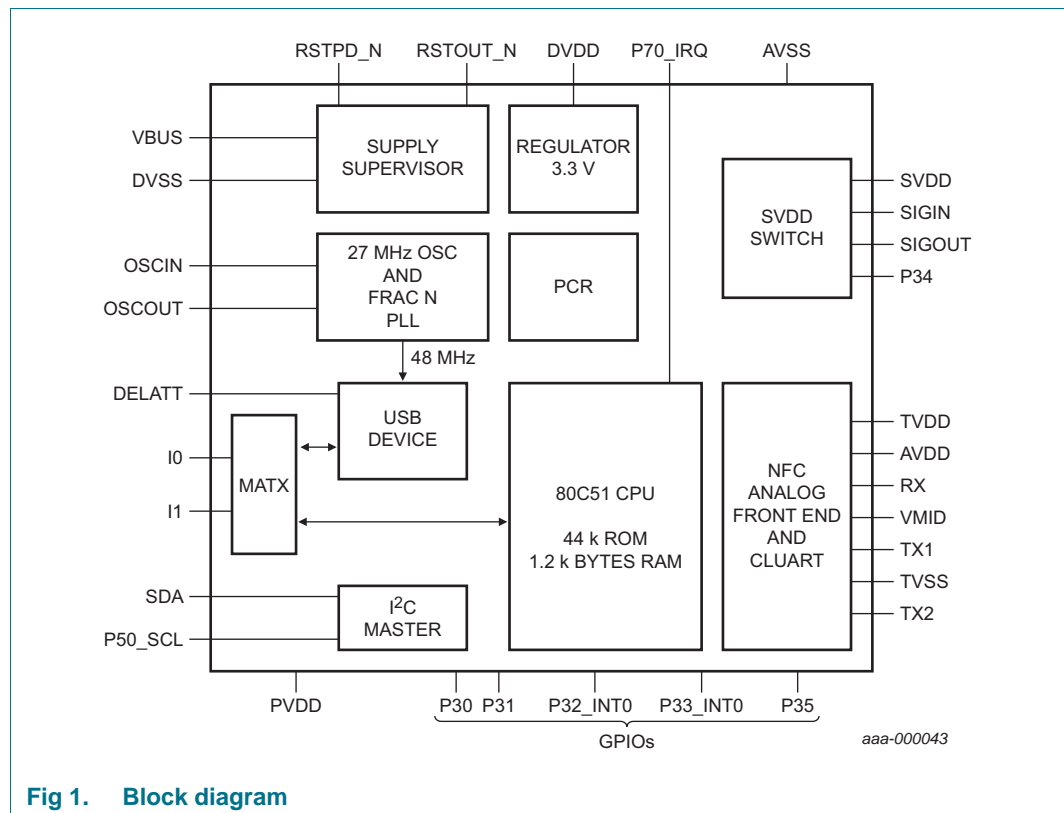

Fig 1. Block diagram

6. Pinning information

6.1 Pinning

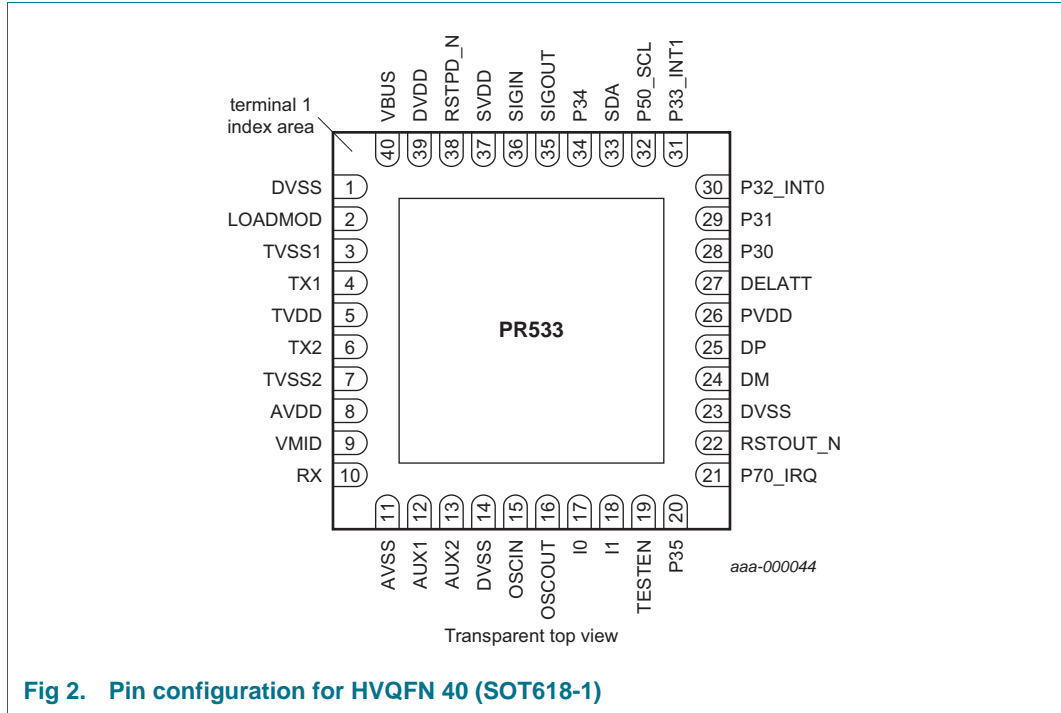

Fig 2. Pin configuration for HVQFN 40 (SOT618-1)

6.2 Pin description

Table 3. PR533 pin description

Symbol	Pin	Type	Pad ref voltage	Description
DVSS	1	G		digital ground
LOADMOD	2	O	DVDD	load modulation output provides digital signal for FeliCa and MIFARE card operating mode
TVSS1	3	G		transmitter ground: supplies the output stage of TX1
TX1	4	O	TVDD	transmitter 1: transmits modulated 13.56 MHz energy carrier
TVDD	5	P		transmitter power supply: supplies the output stage of TX1 and TX2
TX2	6	O	TVDD	transmitter 2: delivers the modulated 13.56 MHz energy carrier
TVSS2	7	G		transmitter ground: supplies the output stage of TX2
AVDD	8	P		analog power supply
VMID	9	P	AVDD	internal reference voltage: This pin delivers the internal reference voltage.
RX	10	I	AVDD	receiver input: Input pin for the reception signal, which is the load modulated 13.56 MHz energy carrier from the antenna circuit
AVSS	11	G		analog ground
AUX1	12	O	DVDD	auxiliary output 1: This pin delivers analog and digital test signals
AUX2	13	O	DVDD	auxiliary output 2: This pin delivers analog and digital test signals
DVSS	14	G		digital ground

Table 3. PR533 pin description ...continued

Symbol	Pin	Type	Pad ref voltage	Description
OSCIN	15	I	AVDD	crystal oscillator input: input to the inverting amplifier of the oscillator. This pin is also the input for an externally generated clock ($f_{clk} = 27.12$ MHz).
OSCOUT	16	O	AVDD	crystal oscillator output: output of the inverting amplifier of the oscillator.
I0	17	I	DVDD	interface mode lines: selects the used host interface; in test mode I0 is used as test signals.
I1	18	I	DVDD	
TESTEN	19	I	DVDD	test enable pin: when set to 1 enable the test mode. when set to 0 reset the TCB and disable the access to the test mode.
P35	20	I/O	DVDD	general purpose I/O signal
P70_IRQ	21	I/O	PVDD	interrupt request: output to signal an interrupt event to the host (Port 7 bit 0)
RSTOUT_N	22	O	PVDD	output reset signal; when LOW it indicates that the circuit is in reset state.
DVSS	23	G		digital ground
DM	24	I/O	PVDD	USB D- data line in USB mode or TX in HSU mode; in test mode this signal is used as input and output test signal
DP	25	I/O	PVDD	USB D+ data line in USB mode or RX in HSU mode; in test mode this signal is used as input and output test signal.
PVDD	26	P		I/O pad power supply
DELATT	27	O	PVDD	optional output for an external 1.5 k Ω resistor connection on D+.
P30	28	I/O	PVDD	general purpose I/O signal. Can be configured to act either as RX line of the second serial interface UART or general purpose I/O. In test mode this signal is used as input and output test signal.
P31	29	I/O	PVDD	general purpose I/O signal. Can be configured to act either as TX line of the second serial interface UART or general purpose I/O. In test mode this signal is used as input and output test signal.
P32_INT0	30	I/O	PVDD	general purpose I/O signal. Can also be used as an interrupt source In test mode this signal is used as input and output test signal.
P33_INT1	31	I/O	PVDD	general purpose I/O signal. Can be used to generate an HZ state on the output of the selected interface for the Host communication and to enter into power-down mode without resetting the internal state of PR533. In test mode this signal is used as input and output test signal.
P50_SCL	32	I/O	DVDD	I ² C-bus clock line - open-drain in output mode
SDA	33	I/O	DVDD	I ² C-bus data line - open-drain in output mode
P34	34	I/O	SVDD	general purpose I/O signal or clock signal for the SAM
SIGOUT	35	O	SVDD	contactless communication interface output: delivers a serial data stream according to NFCIP-1 and output signal for the SAM. In test mode this signal is used as test signal output.
SIGIN	36	I	SVDD	contactless communication interface input: accepts a digital, serial data stream according to NFCIP-1 and input signal from the SAM. In test mode this signal is used as test signal input.
SVDD	37	P		output power for SAM power supply. Switched on by Firmware with an over-load detection. Used as a reference voltage for SAM communication.

Table 3. PR533 pin description ...continued

Symbol	Pin	Type	Pad ref voltage	Description
RSTPD_N	38	I	PVDD	reset and power-down: When LOW, internal current sources are switched off, the oscillator is inhibited, and the input pads are disconnected from the outside world. With a negative edge on this pin the internal reset phase starts.
DVDD	39	P		digital power supply
VBUS	40	P		USB power supply.

[1] Pin types: I= Input, O = Output, I/O = Input/Output, P = Power and G = Ground.

7. Limiting values

Table 4. Limiting values

In accordance with the Absolute Maximum Rating System (IEC 60134).

Symbol	Parameter	Conditions	Min	Max	Unit
V _{DDA}	analog supply voltage		-0.5	+4	V
V _{DDD}	digital supply voltage		-0.5	+4	V
V _{DD(TVDD)}	TVDD supply voltage		-0.5	+4	V
V _{DD(PVDD)}	PVDD supply voltage		-0.5	+4	V
V _{DD(SVDD)}	SVDD supply voltage		-0.5	+4	V
V _{BUS}	bus supply voltage		-0.5	+5.5	V
P _{tot}	total power dissipation		-	500	mW
I _{DD(SVDD)}	SVDD supply current	maximum current in V _{DD} S switch	-	30	mA
V _i	input voltage	TX1, TX2, RX pins	-0.5	+4	V
V _{ESD}	electrostatic discharge voltage	HBM [1]		±2.0	kV
		MM [2]	-	200	V
		CDM [3]	-	±1	kV
T _{stg}	storage temperature		-55	+150	°C
T _j	junction temperature		-40	+125	°C
V _{i(dyn)(RX)}	dynamic input voltage on pin RX	input signal at 13.56 MHz	-0.7	V _{DD(AVDD)} + 1.0	V
V _{i(dyn)(TX1)}	dynamic input voltage on pin TX1	input signal at 13.56 MHz	-1.2	V _{DD(TVDD)} + 1.3	V
V _{i(dyn)(TX2)}	dynamic input voltage on pin TX2	input signal at 13.56 MHz	-1.2	V _{DD(TVDD)} + 1.3	V
I _{TX1}	current on pin TX1	output signal at 13.56 MHz	-300	+300	mA
I _{TX2}	current on pin TX2	output signal at 13.56 MHz	-300	+300	mA

[1] 1500 Ω, 100 pF; EIA/JESD22-A114-A

[2] 0.75 mH, 200 pF; EIA/JESD22-A115-A

[3] Field induced model; EIA/JESD22-C101-C

8. Recommended operating conditions

Table 5. Operating conditions

Symbol	Parameter	Conditions	Min	Typ	Max	Unit	
V _{BUS}	bus supply voltage	V _{SSA} = V _{SSD} = V _{SS(PVSS)} = V _{SS(TVSS)} = 0 V	4.02	5	5.25	V	
		supply voltage (non-USB mode); V _{BUS} = V _{DDD} ; V _{SSA} = V _{SSD} = V _{SS(PVSS)} = V _{SS(TVSS)} = 0 V	2.5	3.3	3.6	V	
V _{DDA}	analog supply voltage	V _{DDA} = V _{DDD} = V _{DD(TVDD)} = V _{DD(PVDD)} ; V _{SSA} = V _{SSD} = V _{SS(PVSS)} = V _{SS(TVSS)} = 0 V	[1][2]	2.5	3.3	3.6	V
V _{DDD}	digital supply voltage	V _{DDA} = V _{DDD} = V _{DD(TVDD)} = V _{DD(PVDD)} ; V _{SSA} = V _{SSD} = V _{SS(PVSS)} = V _{SS(TVSS)} = 0 V	[1][2]	2.5	3.3	3.6	V
V _{DD(TVDD)}	TVDD supply voltage	V _{DDA} = V _{DDD} = V _{DD(TVDD)} = V _{DD(PVDD)} ; V _{SSA} = V _{SSD} = V _{SS(PVSS)} = V _{SS(TVSS)} = 0 V	[1][2]	2.5	3.3	3.6	V
V _{DD(PVDD)}	PVDD supply voltage	supply pad for host interface; V _{DDA} = V _{DDD} = V _{DD(TVDD)} = V _{DD(PVDD)} ; V _{SSA} = V _{SSD} = V _{SS(PVSS)} = V _{SS(TVSS)} = 0 V	[2]	1.6	1.8 to 3.3	3.6	V
T _{amb}	ambient temperature		-30	+25	+85	°C	

[1] V_{SSA}, V_{DDD} and V_{DD(TVDD)} shall always be on the same voltage level.

[2] Supply voltages below 3 V reduces the performance (e.g. the achievable operating distance).

9. Thermal characteristics

Table 6. Thermal characteristics

Symbol	Parameter	Conditions	Min	Typ	Max	Unit
R _{th(j-a)}	thermal resistance from junction to ambient	in free air with exposed pad soldered on a 4 layer Jedec PCB-0.5	-	37	41.1	K/W

10. Characteristics

Unless otherwise specified, the limits are given for the full operating conditions. The typical value is given for 25 °C, V_{DDD} = 3.4 V and V_{DD(PVDD)} = 3 V in non-USB bus power mode, V_{BUS} = 5 V in USB power mode.

Timings are only given from characterization results.

10.1 Power management characteristics

10.1.1 Current consumption characteristics

Typical value using a complementary driver configuration and an antenna matched to 40 Ω between TX1 and TX2 at 13.56 MHz.

Table 7. Current consumption characteristics

Symbol	Parameter	Conditions	Min	Typ	Max	Unit	
I _{pd}	power-down current	V _{DDA} = V _{DDD} = V _{DD(TVDD)} = V _{DD(PVDD)} = 3 V; not powered from USB					
		hard power-down current; not powered from USB; RF level detector off	[1]	-	1.3	10	μA
		soft power-down current; not powered from USB; RF level detector on	[1]	-	9	30	μA
I _{CCSL}	suspended low-power device supply current	V _{BUS} = 5 V; V _{DDA} = V _{DDD} = V _{DD(TVDD)} = V _{DD(PVDD)} = 3 V; V _{DDS} = 0 V; RF level detector on (without resistor on pin DP (D+))	[1]	-	120	250	μA
I _{DDD}	digital supply current	V _{DDA} = V _{DDD} = V _{DD(TVDD)} = V _{DD(PVDD)} = 3 V; RF level detector on	-	12	-	mA	
I _{DDA}	analog supply current	V _{DDA} = V _{DDD} = V _{DD(TVDD)} = V _{DD(PVDD)} = 3 V					
		RF level detector on	-	3	6	mA	
		RF level detector off	-	1.5	5	mA	
I _{DD(PVDD)}	PVDD supply current		[2]	-	-	30	mA
I _{DD(SVDD)}	SVDD supply current	sam_switch_en set to 1	[3]	-	-	30	mA
I _{DD(TVDD)}	TVDD supply current	continuous wave; V _{DD(TVDD)} = 3 V	[4][5]	-	60	100	mA

- [1] I_{pd} is the total currents over all supplies.
- [2] I_{DD(PVDD)} depends on the overall load at the digital pins.
- [3] I_{DD(SVDD)} depends on the overall load on V_{DD(SVDD)} pad.
- [4] I_{DD(TVDD)} depends on V_{DD(TVDD)} and the external circuitry connected to TX1 and TX2.
- [5] During operation with a typical circuitry the overall current is below 100 mA.

10.1.2 Voltage regulator characteristics

Table 8. Voltage regulator characteristics[1]

Symbol	Parameter	Conditions	Min	Typ	Max	Unit
V _{BUS}	bus supply voltage	USB mode; V _{SS} = 0 V	4.02	5	5.25	V
V _{DDD}	digital supply voltage	after inrush current limitation (USB mode); from I _{VDDD} = 0 mA to I _{VDDD} = 150 mA	2.95	3.3	3.6	V
I _{BUS}	bus supply current	USB mode; measure on V _{BUS}	-	-	150	mA
I _{inrush(lim)}	inrush current limit	at power-up (curlimoff = 0)	-	-	100	mA
V _{th(rst)reg}	regulator reset threshold voltage	regulator reset	1.90	2.15	2.40	V
V _{th(rst)reg(hys)}	regulator reset threshold voltage hysteresis		35	60	85	mV
	V _{DDD} decoupling capacitor		8	10	-	μF

- [1] The internal regulator is only enabled when the USB interface is selected by I0 and I1.

10.2 Antenna presence self test thresholds

The values in [Table 9](#) are guaranteed by design. Only functional is done in production for cases andet_ithl[1:0] = 10b and for andet_ithh[2:0] = 011b.

Table 9. Antenna presence detection

Parameter	Conditions	Min	Typ	Max	Unit
I_{VDD} lower current threshold for antenna presence detection					
andet_ith[1:0]	00b	-	5	-	mA
	01b	-	15	-	mA
	10b	-	25	-	mA
	11b	-	35	-	mA
I_{VDD} upper current threshold for antenna presence detection					
andet_ith[2:0]	000b	-	45	-	mA
	001b	-	60	-	mA
	010b	-	75	-	mA
	011b	-	90	-	mA
	100b	-	105	-	mA
	101b	-	120	-	mA
	110b	-	135	-	mA
	111b	-	150	-	mA

10.3 Typical 27.12 MHz Crystal requirements

Table 10. Crystal requirements

Symbol	Parameter	Conditions	Min	Typ	Max	Unit
f_{xtal}	crystal frequency		27.107	27.12	27.133	MHz
ESR	equivalent series resistance		-	-	100	Ω
C_L	load capacitance		-	10	-	pF
P_{xtal}	crystal power dissipation		100	-	-	μW

10.4 Pin characteristics for 27.12 MHz XTAL Oscillator (OSCIN, OSCOUT)

Table 11. Pin characteristics for 27.12 MHz XTAL Oscillator (OSCIN, OSCOUT)

Symbol	Parameter	Conditions	Min	Typ	Max	Unit
I_{LI}	input leakage current	RSTPD_N = 0 V	-1	-	+1	mA
V_{IH}	HIGH-level input voltage		$0.7 \times V_{DDA}$	-	V_{DDA}	V
V_{IL}	LOW-level input voltage		0	-	$0.3 \times V_{DDA}$	V
V_{OH}	HIGH-level output voltage		-	1.1	-	V
V_{OL}	LOW-level output voltage		-	0.2	-	V
f_{clk}	clock frequency		-0.05 %	27.12	+0.05 %	MHz
δ	duty cycle		40	50	60	%
$\varphi_{n(th)}$	phase noise threshold	[1]	-	-	-140	dBc/Hz
$f_{\varphi n(th)}$	phase noise threshold frequency	$\varphi_{n(th)} = -140\text{dBc/Hz};$ -20dB/decade slope	[1]	-	50	kHz
OSCIN						
V_i	input voltage	DC	-	0.65	-	V
C_i	input capacitance	$V_{DDA} = 2.8\text{ V}; V_i(\text{DC}) = 0.65\text{ V};$ $V_i(\text{AC}) = 1\text{ V p-p}$	-	2	-	pF
OSCOUT						
C_i	input capacitance		-	2	-	pF

[1] $\varphi_{n(th)}$ and $f_{\varphi n(th)}$ define the mask for maximum acceptable phase noise of the clock signal at the OSCIN, OSCOUT inputs. See [Figure 3](#) "27.12 MHz input clock phase noise spectrum mask".

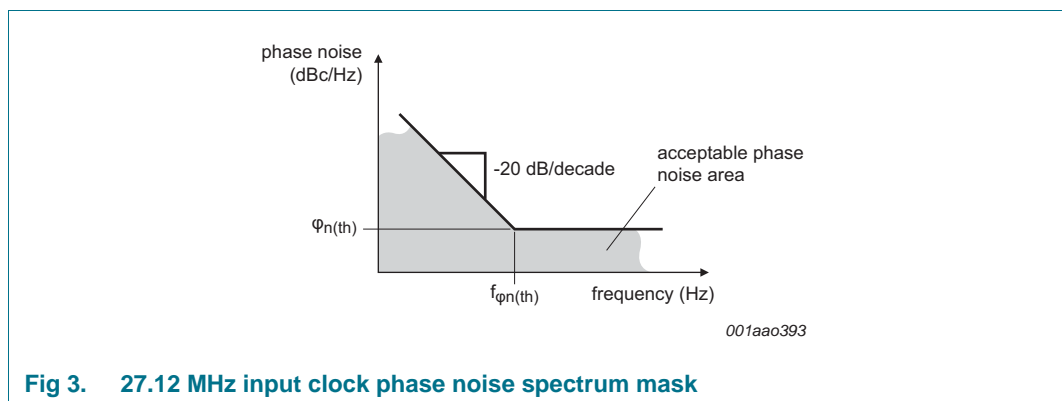

Fig 3. 27.12 MHz input clock phase noise spectrum mask

10.5 RSTPD_N input pin characteristics

Table 12. RSTPD_N input pin characteristics

Symbol	Parameter	Conditions	Min	Typ	Max	Unit
V_{IH}	HIGH-level input voltage		$V_{DD(PVDD)} - 0.4$	-	$V_{DD(PVDD)}$	V
V_{IL}	LOW-level input voltage		0	-	0.4	V
I_{IH}	HIGH-level input current	$V_I = V_{DD(PVDD)}$	-1	-	1	μA
I_{IL}	LOW-level input current	$V_I = 0\text{ V}$	-1	-	1	μA
C_i	input capacitance		-	2.5	-	pF

10.6 Input pin characteristics for I0, I1 and TESTEN

Table 13. Input pin characteristics for I0, I1 and TESTEN

Symbol	Parameter	Conditions	Min	Typ	Max	Unit
V_{IH}	HIGH-level input voltage	[1]	$0.7 \times V_{DDD}$	-	V_{DDD}	V
V_{IL}	LOW-level input voltage	[2]	0	-	$0.3 \times V_{DDD}$	V
I_{IH}	HIGH-level input current	I0 and I1; $V_I = V_{DDD}$	[3] -1	-	1	μA
I_{IL}	LOW-level input current	$V_I = 0\text{ V}$	-1	-	1	μA
C_i	input capacitance		-	2.5	-	pF

[1] To minimize power consumption when in soft power-down mode, the limit is $V_{DDD} - 0.4\text{ V}$.

[2] To minimize power consumption when in soft power-down mode, the limit is 0.4 V .

[3] TESTEN should never be set to high level in the application. It is used for production test purpose only. It is recommended to connect TESTEN to ground although there is a pull-down included.

10.7 RSTOUT_N output pin characteristics

Table 14. RSTOUT_N output pin characteristics

Symbol	Parameter	Conditions	Min	Typ	Max	Unit
V _{OH}	HIGH-level output voltage	V _{DD(PVDD)} = 3 V; I _{OH} = -4 mA	0.7 × V _{DD(PVDD)}	-	V _{DD(PVDD)}	V
		V _{DD(PVDD)} = 1.8 V; I _{OH} = -2 mA [1]	0.7 × V _{DD(PVDD)}	-	V _{DD(PVDD)}	V
V _{OL}	LOW-level output voltage	V _{DD(PVDD)} = 3 V; I _{OL} = 4 mA	0	-	0.3 × V _{DD(PVDD)}	V
		V _{DD(PVDD)} = 1.8 V; I _{OL} = 2 mA [1]	0	-	0.3 × V _{DD(PVDD)}	V
I _{OH}	HIGH-level output current	V _{DD(PVDD)} = 3 V; V _{OH} = 0.8 × V _{DD(PVDD)} [2]	-4	-	-	mA
		V _{DD(PVDD)} = 1.8 V; V _{OH} = 0.7 × V _{DD(PVDD)}	-2	-	-	mA
I _{OL}	LOW-level output current	V _{DD(PVDD)} = 3 V; V _{OL} = 0.2 × V _{DD(PVDD)} [2]	4	-	-	mA
		V _{DD(PVDD)} = 1.8 V; V _{OL} = 0.3 × V _{DD(PVDD)}	2	-	-	mA
C _L	load capacitance			-	30	pF
t _r	rise time	V _{DD(PVDD)} = 3 V; V _{OH} = 0.8 × V _{DD(PVDD)} ; C _L = 30 pF	-	-	13.5	ns
		V _{DDP} = 1.8 V; V _{OH} = 0.7 × V _{DD(PVDD)} ; C _L = 30 pF	-	-	10.8	ns
t _f	fall time	V _{DD(PVDD)} = 3 V; V _{OL} = 0.2 × V _{DD(PVDD)} ; C _L = 30 pF	-	-	13.5	ns
		V _{DD(PVDD)} = 1.8 V; V _{OL} = 0.3 × V _{DD(PVDD)} ; C _L = 30 pF	-	-	10.8	ns

[1] Data at V_{DD(PVDD)} = 1.8V are only given from characterization results.

[2] I_{OH} and I_{OL} give the output drive capability from which the rise and fall times may be calculated as a function of the load capacitance.

10.8 Input/output characteristics for pin P70_IRQ

Table 15. Input/output pin characteristics for pin P70_IRQ

Symbol	Parameter	Conditions	Min	Typ	Max	Unit
V _{IH}	HIGH-level input voltage	[1]	$0.7 \times V_{DD(PVDD)}$	-	V _{DD(PVDD)}	V
V _{IL}	LOW-level input voltage	[2]	0	-	$0.3 \times V_{DD(PVDD)}$	V
V _{OH}	HIGH-level output voltage	push-pull mode; V _{DD(PVDD)} = 3 V; I _{OH} = -4 mA	$0.7 \times V_{DD(PVDD)}$	-	V _{DD(PVDD)}	V
		push-pull mode; V _{DD(PVDD)} = 1.8 V; I _{OH} = -2 mA	[3] $0.7 \times V_{DD(PVDD)}$	-	V _{DD(PVDD)}	V
V _{OL}	LOW-level output voltage	push-pull mode; V _{DD(PVDD)} = 3 V; I _{OL} = 4 mA	0	-	$0.3 \times V_{DD(PVDD)}$	V
		push-pull mode; V _{DD(PVDD)} = 1.8 V; I _{OL} = 2 mA	[3] 0	-	$0.3 \times V_{DD(PVDD)}$	V
I _{IH}	HIGH-level input current	input mode; V _I = V _{DDD}	-1	-	1	μA
I _{IL}	LOW-level input current	input mode; V _I = 0 V	-1	-	1	μA
I _{OH}	HIGH-level output current	V _{DD(PVDD)} = 3 V; V _{OH} = $0.8 \times V_{DD(PVDD)}$	[5] -4	-	-	mA
I _{OL}	LOW-level output current	V _{DD(PVDD)} = 3 V; V _{OL} = $0.2 \times V_{DD(PVDD)}$	[5] 4	-	-	mA
I _{LI}	input leakage current	RSTPD_N = 0.4 V	-1	-	1	μA
C _i	input capacitance		-	2.5		pF
C _L	load capacitance		-	-	30	pF
t _r	rise time	V _{DD(PVDD)} = 3 V; V _{OH} = $0.8 \times V_{DD(PVDD)}$; C _L = 30 pF	-	-	13.5	ns
		V _{DD(PVDD)} = 1.8 V; V _{OH} = $0.7 \times V_{DD(PVDD)}$; C _L = 30 pF	-	-	10.8	ns
t _f	fall time	V _{DD(PVDD)} = 3 V; V _{OL} = $0.2 \times V_{DD(PVDD)}$; C _L = 30 pF	-	-	13.5	ns
		V _{DD(PVDD)} = 1.8 V; V _{OL} = $0.3 \times V_{DD(PVDD)}$; C _L = 30 pF	-	-	10.8	ns

[1] To minimize power consumption when in soft power-down mode, the limit is $V_{DD(PVDD)} - 0.4$ V.

[2] To minimize power consumption when in soft power-down mode, the limit is 0.4 V.

[3] Data at $V_{DD(PVDD)} = 1.8$ V are only given from characterization results.

[4] The I_{OH} and I_{OL} give the output driving capability and allow to calculate directly the rise and fall time as function of the load capacitance.

10.9 Input/output pin characteristics for P30 / UART_RX, P31 / UART_TX, P32_INT0, P33_INT1

Table 16. Input/output pin characteristics for P30 / UART_RX, P31 / UART_TX, P32_INT0, P33_INT1

Symbol	Parameter	Conditions	Min	Typ	Max	Unit
V _{IH}	HIGH-level input voltage	[1]	0.7 × V _{DD(PVDD)}	-	V _{DD(PVDD)}	V
V _{IL}	LOW-level input voltage	[2]	0	-	0.3 × V _{DD(PVDD)}	V
V _{OH}	HIGH-level output voltage	push-pull mode; V _{DD(PVDD)} = 3 V; I _{OH} = -4 mA	V _{DD(PVDD)} - 0.4	-	V _{DD(PVDD)}	V
		V _{DD(PVDD)} = 1.8 V; I _{OH} = -2 mA	[3] V _{DD(PVDD)} - 0.4	-	V _{DD(PVDD)}	V
V _{OL}	LOW-level output voltage	push-pull mode; V _{DD(PVDD)} = 3 V; I _{OL} = 4 mA	0	-	0.4	V
		V _{DD(PVDD)} = 1.8 V; I _{OL} = 2 mA	[3] 0	-	0.4	V
I _{IH}	HIGH-level input current	input mode; V _I = V _{DD(PVDD)}	-1	-	1	μA
I _{IL}	LOW-level input current	input mode; V _I = 0 V	-1	-	1	μA
I _{OH}	HIGH-level output current	V _{DD(PVDD)} = 3 V; V _{OH} = 0.8 × V _{DD(PVDD)}	[4] -4	-	-	mA
I _{OL}	LOW-level output current	V _{DD(PVDD)} = 3 V; V _{OL} = 0.2 × V _{DD(PVDD)}	[4] 4	-	-	mA
I _{LI}	input leakage current	RSTPD_N = 0.4 V	-1	-	1	μA
C _i	input capacitance		-	2.5	-	pF
C _L	load capacitance		-	-	30	pF
t _r	rise time	V _{DD(PVDD)} = 3 V; V _{OH} = 0.8 × V _{DD(PVDD)} ; C _L = 30 pF	-	-	13.5	ns
		V _{DD(PVDD)} = 1.8 V; V _{OH} = 0.7 × V _{DD(PVDD)} ; C _L = 30 pF	-	-	10.8	ns
t _f	fall time	V _{DD(PVDD)} = 3 V; V _{OL} = 0.2 × V _{DD(PVDD)} ; C _L = 30 pF	-	-	13.5	ns
		V _{DD(PVDD)} = 1.8 V; V _{OL} = 0.3 × V _{DD(PVDD)} ; C _L = 30 pF	-	-	10.8	ns

[1] To minimize power consumption when in soft power-down mode, the limit is V_{DD(PVDD)} - 0.4 V.

[2] To minimize power consumption when in soft power-down mode, the limit is 0.4 V

[3] Data at V_{DD(PVDD)} = 1.8 V are only given from characterization results.

[4] The I_{OH} and I_{OL} give the output driving capability and allow to calculate directly the rise and fall time as function of the load capacitance.

10.10 Input/output pin characteristics for P35

Table 17. Input/output pin characteristics for P35

Symbol	Parameter	Conditions	Min	Typ	Max	Unit
V _{IH}	HIGH-level input voltage		[1] $0.7 \times V_{DD3}$	-	V _{DD3}	V
V _{IL}	LOW-level input voltage		[2] 0	-	$0.3 \times V_{DD3}$	V
V _{OH}	HIGH-level output voltage	V _{DD3} = 3 V; I _{OH} = -4 mA	V _{DD3} - 0.4	-	V _{DD3}	V
V _{OL}	LOW-level output voltage	V _{DD3} = 3 V; I _{OL} = 4 mA	0	-	0.4	V
I _{IH}	HIGH-level input current	V _I = V _{DD3}	-1	-	1	μA
I _{IL}	LOW-level input current	V _I = 0 V	-1	-	1	μA
I _{OH}	HIGH-level output current	V _{DD3} = 3 V; V _{OH} = $0.8 \times V_{DD(PVDD)}$	[3] -4	-	-	mA
I _{OL}	LOW-level output current	V _{DD3} = 3 V; V _{OL} = $0.2 \times V_{DD(PVDD)}$	[3] 4	-	-	mA
I _{LI}	input leakage current	RSTPD_N = 0.4 V	-1	-	1	μA
C _i	input capacitance		-	2.5	-	pF
C _L	load capacitance		-	-	30	pF
t _r	rise time	V _{DD3} = 3 V; V _{OH} = $0.8 \times V_{DD3}$; C _L = 30 pF	-	-	13.5	ns
		V _{DD3} = 1.8 V; V _{OH} = $0.7 \times V_{DD3}$; C _L = 30 pF	-	-	10.8	ns
t _f	fall time	V _{DD3} = 3 V; V _{OL} = $0.2 \times V_{DD3}$; C _L = 30 pF	-	-	13.5	ns
		V _{DD3} = 1.8 V; V _{OL} = $0.3 \times V_{DD3}$; C _L = 30 pF	-	-	10.8	ns

[1] To minimize power consumption when in soft power-down mode, the limit is V_{DD3} - 0.4 V.

[2] To minimize power consumption when in soft power-down mode, the limit is 0.4 V.

[3] The I_{OH} and I_{OL} give the output driving capability and allow to calculate directly the rise and fall time as function of the load capacitance.

10.11 Input/output pin characteristics for DP and DM

Table 18. Input/output pin characteristics for DP and DM for USB interface

Symbol	Parameter	Conditions	Min	Typ	Max	Unit
V _{IH}	HIGH-level input voltage	V _{DD(PVDD)} = 3.3 V	2	-	3.6	V
V _{IL}	LOW-level input voltage		[1] 0	-	0.8	V
V _{OH}	HIGH-level output voltage	V _{DD(PVDD)} = 3.3 V; R _{PD} = 1.5 Ω to V _{SS}	2.8	-	V _{DD(PVDD)}	V
V _{OL}	LOW-level output voltage	V _{DD(PVDD)} = 3.3 V; R _{PD} = 1.5 Ω to V _{DD(PVDD)}	0	-	0.3	V
I _{OH}	HIGH-level output current	V _{DD(PVDD)} = 3.3 V; V _{OH} = 0.8 × V _{DD(PVDD)}	[2] -4	-	-	mA
		V _{DD(PVDD)} = 1.8 V; V _{OH} = 0.7 × V _{DD(PVDD)}	-2	-	-	mA
I _{OL}	LOW-level output current	V _{DD(PVDD)} = 3.3 V; V _{OL} = 0.2 × V _{DD(PVDD)}	[2] 4	-	-	mA
		V _{DD(PVDD)} = 1.8 V; V _{OL} = 0.3 × V _{DD(PVDD)}	2	-	-	mA
I _{IH}	HIGH-level input current	V _I = V _{DD(PVDD)}	-	-	1	μA
I _{IL}	LOW-level input current	V _I = 0 V	-	-	1	μA
I _{LI}	input leakage current	RSTPD_N = 0 V	-1	-	+1	μA
C _i	input capacitance		-	2.5	3.5	pF
Z _{INP}	input impedance exclusive of pull-up/pull-down (for low-/full speed)		300	-	-	kΩ
Z _{DRV}	driver output impedance for driver which is not high-speed capable		28	-	44	Ω
t _{FDRATE}	full-speed data rate for devices which are not high-speed capable		11.97	-	12.03	Mb/s
t _{DJ1}	source jitter total (including frequency tolerance) to next transition		-3.5	-	+3.5	ns
t _{DJ2}	source jitter total (including frequency tolerance) for paired transitions		-4	-	+4	ns
t _{FDEOP}	source jitter for differential transition to SE0 transition		-2	-	+5	ns
t _{JR1}	receiver jitter to next transition		-18.5	-	+18.5	ns
t _{JR2}	receiver jitter for paired transitions		-9	-	+9	ns
t _{FEOPT}	source SE0 interval of EOP		160	-	175	ns
t _{FEOPR}	receiver SE0 interval of EOP		82	-	-	ns
t _{FST}	width of SE0 interval during differential transition		-	-	14	ns

[1] The value does not guarantee the power-down consumptions. To reach the specified power-down consumptions, the limit is 0.4 V.

[2] The I_{OH} and I_{OL} give the output driving capability and allow to calculate directly the rise and fall time as function of the load capacitance.

Table 19. USB DP/DM differential receiver input levels

Symbol	Parameter	Conditions	Min	Typ	Max	Unit
V_{DI}	differential input sensitivity voltage	-	0.2	-	-	V
V_{CM}	differential common mode voltage range	-	0.8	-	2.5	V

Table 20. USB DP/DM driver characteristics

Symbol	Parameter	Conditions	Min	Typ	Max	Unit
t_r	rise time	$C_L = 50 \text{ pF}$; 10 % to 90 % of $(V_{OH} - V_{OL})$	4	-	20	ns
t_f	fall time	$C_L = 50 \text{ pF}$; 10 % to 90 % of $(V_{OH} - V_{OL})$	4	-	20	ns
t_{FRFM}	differential rise and fall time matching	(t_{FR}/t_{FF}) ; excluding the first transition from Idle state	90	-	111.1	%
V_{CRS}	output signal cross-over voltage	excluding the first transition from Idle state	1.3	-	2.0	V

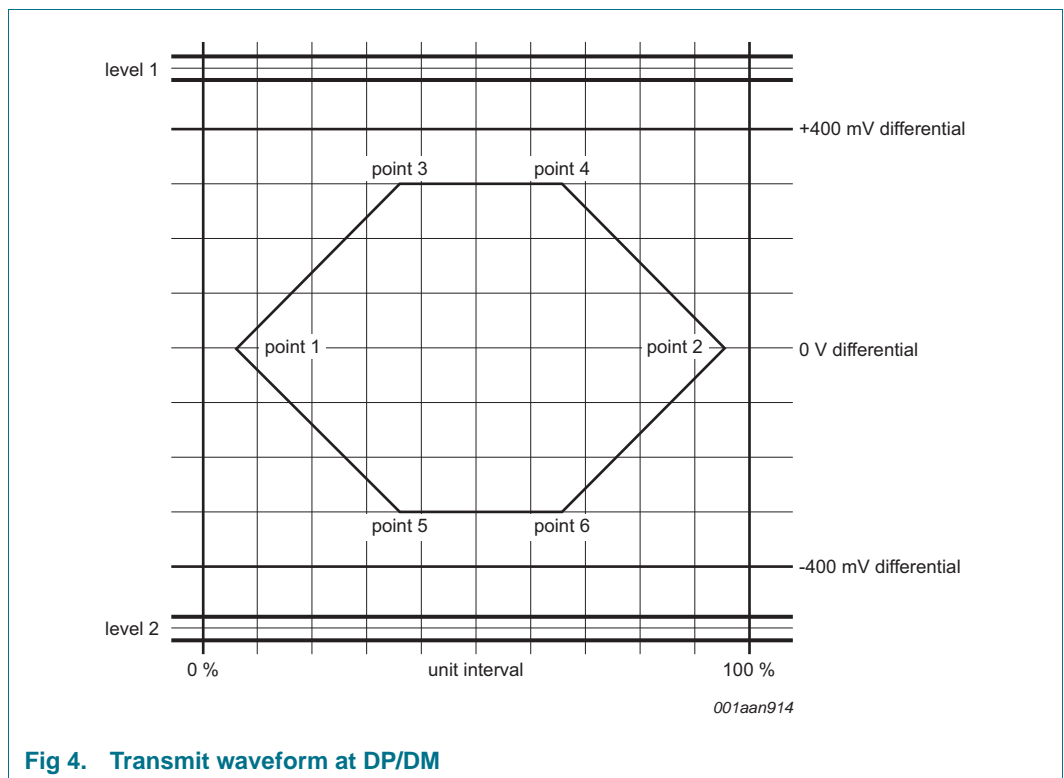

Fig 4. Transmit waveform at DP/DM

Table 21. Input Pin characteristics for DP for HSU interface

Symbol	Parameter	Conditions	Min	Typ	Max	Unit
V _{IH}	HIGH-level input voltage	[1]	0.7 × V _{DD(PVDD)}	-	V _{DD(PVDD)}	V
V _{IL}	LOW-level input voltage	[2]	0	-	0.3 × V _{DD(PVDD)}	V
I _{IH}	HIGH-level input current	V _i = V _{DD(PVDD)}	-	-	1	mA
I _{IL}	LOW-level input current	V _i = 0 V	-	-	1	mA
I _{LI}	input leakage current	RSTPD_N = 0 V	-1	-	1	mA
C _i	input capacitance		-	2.5	3.5	pF

[1] The value does not guarantee the power-down consumptions. To reach the specified power-down consumptions, the limit is V_{DD(PVDD)} – 0.4 V.

[2] The value does not guarantee the power-down consumptions. To reach the specified power-down consumptions, the limit is 0.4 V.

Table 22. Output Pin characteristics for DM for HSU interface

Symbol	Parameter	Conditions	Min	Typ	Max	Unit
V _{OH}	HIGH-level output voltage	V _{DD(PVDD)} = 3 V; I _{OH} = –4 mA	V _{DD(PVDD)} – 0.4	-	V _{DD(PVDD)}	V
		V _{DD(PVDD)} = 1.8 V; I _{OH} = –2 mA	V _{DD(PVDD)} – 0.4	-	V _{DD(PVDD)}	V
V _{OL}	LOW-level output voltage	V _{DD(PVDD)} = 3 V; I _{OL} = –4 mA	0	-	0.4	V
		V _{DD(PVDD)} = 1.8 V; I _{OL} = –2 mA	0	-	0.4	V
I _{OH}	HIGH-level output current	V _{DD(PVDD)} = 3 V; V _{OH} = 0.8 × V _{DD(PVDD)} [1]	–4	-	-	mA
		V _{DD(PVDD)} = 1.8 V; V _{OH} = 0.7 × V _{DD(PVDD)}	–2	-	-	mA
I _{OL}	LOW-level output current	V _{DD(PVDD)} = 3.3 V; V _{OL} = 0.2 × V _{DD(PVDD)} [1]	4	-	-	mA
		V _{DD(PVDD)} = 1.8 V; V _{OL} = 0.3 × V _{DD(PVDD)}	2	-	-	mA
I _{LI}	input leakage current	RSTPD_N = 0 V	–1	-	1	mA
C _L	load capacitance		-	-	30	pF
t _r	rise time	V _{DDP} = 3 V; V _{OH} = 0.8 × V _{DD(PVDD)} ; C _L = 30 pF	-	-	13.5	ns
		V _{DD(PVDD)} = 1.8 V; V _{OH} = 0.7 × V _{DD(PVDD)} ; C _L = 30 pF	-	-	10.8	ns
t _f	fall time	V _{DD(PVDD)} = 3 V; V _{OL} = 0.2 × V _{DD(PVDD)} ; C _L = 30 pF	-	-	13.5	ns
		V _{DDP} = 1.8 V; V _{OL} = 0.3 × V _{DD(PVDD)} ; C _L = 30 pF	-	-	10.8	ns

[1] The I_{OH} and I_{OL} give the output driving capability and allow to calculate directly the rise and fall time as function of the load capacitance

10.12 Input pin characteristics for SCL

Table 23. Input/output drain output pin characteristics for SCL I²C interface

Symbol	Parameter	Conditions	Min	Typ	Max	Unit
V _{IH}	HIGH-level input voltage	[1]	0.7 × V _{DD(PVDD)}	-	V _{DD}	V
V _{IL}	LOW-level input voltage	[2]	0	-	0.3 × V _{DD}	V
V _{OL}	LOW-level output voltage	V _{DD} = 3 V; I _{OL} = -4 mA	0	-	0.3	V
I _{IH}	HIGH-level input current	V _I = V _{DD}	-1	-	1	μA
I _{IL}	LOW-level input current	V _I = 0 V	-1	-	1	μA
I _{LI}	input leakage current	RSTPD_N = 0.4 V	-1	-	1	μA
C _i	input capacitance		-	2.5		pF
C _L	load capacitance		-	-	30	pF
t _r	rise time of both SDA and SCL signals	[3]	20	-	300	ns
t _f	fall time of both SDA and SCL signals	[3]	20	-	300	ns

[1] To minimize power consumption when in soft power-down mode, the limit is V_{DD} - 0.4 V.

[2] To minimize power consumption when in soft power-down mode, the limit is 0.4 V.

[3] The PR533 has a slope control according to the I²C-bus specification for the Fast mode. The slope control is always present and not dependent of the I²C-bus speed.

10.13 Input/output pin characteristics for SDA

Table 24. Input/output drain output pin characteristics for SDA I²C interface

Symbol	Parameter	Conditions	Min	Typ	Max	Unit
V _{IH}	HIGH-level input voltage	[1]	0.7 × V _{DD(PVDD)}	-	V _{DD}	V
V _{IL}	LOW-level input voltage	[2]	0	-	0.3 × V _{DD}	V
V _{OL}	LOW-level output voltage	V _{DD} = 3 V; I _{OL} = -4 mA	0	-	0.3	V
I _{IH}	HIGH-level input current	V _I = V _{DD}	-1	-	1	μA
I _{IL}	LOW-level input current	V _I = 0 V	-1	-	1	μA
I _{LI}	input leakage current	RSTPD_N = 0.4 V	-1	-	1	μA
C _i	input capacitance		-	2.5		pF
C _L	load capacitance		-	-	30	pF
t _r	rise time of both SDA and SCL signals	[3]	20	-	300	ns
t _f	fall time of both SDA and SCL signals	[3]	20	-	300	ns

[1] To minimize power consumption when in soft power-down mode, the limit is V_{DD} - 0.4 V.

[2] To minimize power consumption when in soft power-down mode, the limit is 0.4 V.

[3] The PR533 has a slope control according to the I²C-bus specification for the Fast mode. The slope control is always present and not dependent of the I²C-bus speed.

10.14 Output pin characteristics for DELATT

Table 25. Output pin characteristics for DELATT

Symbol	Parameter	Conditions	Min	Typ	Max	Unit
V _{OH}	HIGH-level output voltage		[1] 0.7 × V _{DD(SVDD)}	-	V _{DD(SVDD)}	V
V _{IL}	LOW-level input voltage		0	-	0.3 × V _{DD(PVDD)}	V
I _{IH}	HIGH-level input current	input mode; V _I = V _{DD(SVDD)}	-1	-	1	μA
I _{IL}	LOW-level input current	input mode; V _I = 0 V	-1	-	1	μA
I _{LI}	input leakage current	RSTPD_N = 0.4 V	-1	-	1	μA
C _i	input capacitance		-	2.5	-	pF

[1] To minimize power consumption when in soft power-down mode, the limit is V_{DD(PVDD)} - 0.4 V.

10.15 Input pin characteristics for SIGIN

Table 26. Input/output pin characteristics for SIGIN

Symbol	Parameter	Conditions	Min	Typ	Max	Unit
V _{IH}	HIGH-level input voltage		[1] 0.7 × V _{DD(SVDD)}	-	V _{DD(SVDD)}	V
V _{IL}	LOW-level input voltage		[2] 0	-	0.3 × V _{DD(SVDD)}	V
I _{IH}	HIGH-level input current	V _I = V _{DD(SVDD)}	-1	-	+1	μA
I _{IL}	LOW-level input current	V _I = 0 V	-1	-	+1	μA
I _{LI}	input leakage current	RSTPD_N = 0.4 V	-1	-	+1	μA
C _i	input capacitance		-	2.5	-	pF

[1] To minimize power consumption when in soft power-down mode, the limit is V_{DD(SVDD)} - 0.4 V.

[2] To minimize power consumption when in soft power-down mode, the limit is 0.4 V.

10.16 Output pin characteristics for SIGOUT

Table 27. Output pin characteristics for SIGOUT

Symbol	Parameter	Conditions	Min	Typ	Max	Unit
V _{OH}	HIGH-level output voltage	V _{DDD} - 0.1 < V _{DD(SVDD)} < V _{DDD} I _{OH} = -4 mA	V _{DD(SVDD)} - 0.4	-	V _{DD(SVDD)}	V
V _{OL}	LOW-level output voltage	V _{DDD} - 0.1 < V _{DD(SVDD)} < V _{DDD} I _{OL} = +4 mA	0	-	0.4	V
I _{OH}	HIGH-level output current	V _{DDD} - 0.1 < V _{DD(SVDD)} < V _{DDD} I _{OH} = -4 mA	-0.4	-	-	mA
I _{OL}	LOW-level output current	V _{DDD} - 0.1 < V _{DD(SVDD)} < V _{DDD} I _{OL} = +4 mA	4	-	-	mA
I _{LI}	input leakage current	RSTPD_N = 0.4 V	-1	-	+1	μA
C _i	input capacitance		-	2.5	-	pF
C _L	load capacitance		-	-	30	pF
t _r	rise time	V _{DD(SVDD)} = 3 V; V _{OH} = 0.8 × V _{DD(SVDD)} ; C _{out} = 30 pF	-	-	9	ns
t _f	fall time	V _{DD(SVDD)} = 3 V; V _{OL} = 0.2 × V _{DD(SVDD)} ; C _{out} = 30 pF	-	-	9	ns

10.17 Input/output pin characteristics for P34

Table 28. Input/output pin characteristics for P34

Symbol	Parameter	Conditions	Min	Typ	Max	Unit
V _{IH}	HIGH-level input voltage		[1] 0.7 × V _{DD(SVDD)}	-	V _{DD(SVDD)}	V
V _{IL}	LOW-level input voltage		[2] 0	-	0.3 × V _{DD(SVDD)}	V
V _{OH}	HIGH-level output voltage	push-pull; V _{DDD} - 0.1 < V _{DD(SVDD)} < V _{DDD} I _{OH} = -4 mA	V _{DD(SVDD)} - 0.4	-	V _{DD(SVDD)}	V
V _{OL}	LOW-level output voltage	push-pull; V _{DDD} - 0.1 < V _{DD(SVDD)} < V _{DDD} I _{OH} = +4 mA	0	-	0.4	V
I _{IH}	HIGH-level input current	input mode; V _I = V _{DD(SVDD)}	-1	-	+1	μA
I _{IL}	LOW-level input current	input mode; V _I = 0 V	-1	-	+1	μA
V _{OH}	HIGH-level output voltage	V _{DDD} - 0.1 < V _{DD(SVDD)} < V _{DDD} I _{OH} = -4 mA	-0.4	-	-	V
V _{OL}	LOW-level output voltage	V _{DDD} - 0.1 < V _{DD(SVDD)} < V _{DDD} I _{OL} = +4 mA	4	-	-	V
I _{LI}	input leakage current	RSTPD_N = 0.4 V	-1	-	+1	μA
C _i	input capacitance		-	2.5		pF
C _L	load capacitance		-		30	pF
t _r	rise time	V _{DDD} = 0.1 < V _{DDD} V _{OH} = 0.8 × V _{DD(SVDD)} ; C _{out} = 30 pF	[3] -	13.5	-	ns
t _f	fall time	V _{DDD} = 0.1 < V _{DDD} V _{OL} = 0.2 × V _{DD(SVDD)} ; C _{out} = 30 pF	[3] -	13.5	-	ns

[1] To minimize power consumption when in soft power-down mode, the limit is V_{DD(SVDD)} - 0.4 V.

[2] To minimize power consumption when in soft power-down mode, the limit is 0.4 V.

[3] I_{OH} and I_{OL} specify the output drive capability from which the rise and fall times may be calculated as a function of the load capacitance.

10.18 Output pin characteristics for LOADMOD

Table 29. Output pin characteristics for LOADMOD

Symbol	Parameter	Conditions	Min	Typ	Max	Unit
V _{OH}	HIGH-level output voltage	V _{DDD} = 3 V; I _{OH} = -4 mA	V _{DDD} - 0.4	-	V _{DDD}	V
V _{OL}	LOW-level output voltage	V _{DDD} = 3 V; I _{OL} = 4 mA	0	-	0.4	V
C _L	load capacitance		-	-	10	pF
t _r	rise time	V _{DDD} = 3 V; V _{OH} = 0.8 × V _{DDD} ; C _{out} = 10 pF	-	-	4.5	ns
t _f	fall time	V _{DDD} = 3 V; V _{OL} = 0.2 × V _{DDD} ; C _{out} = 10 pF	-	-	4.5	ns

10.19 Input pin characteristics for RX

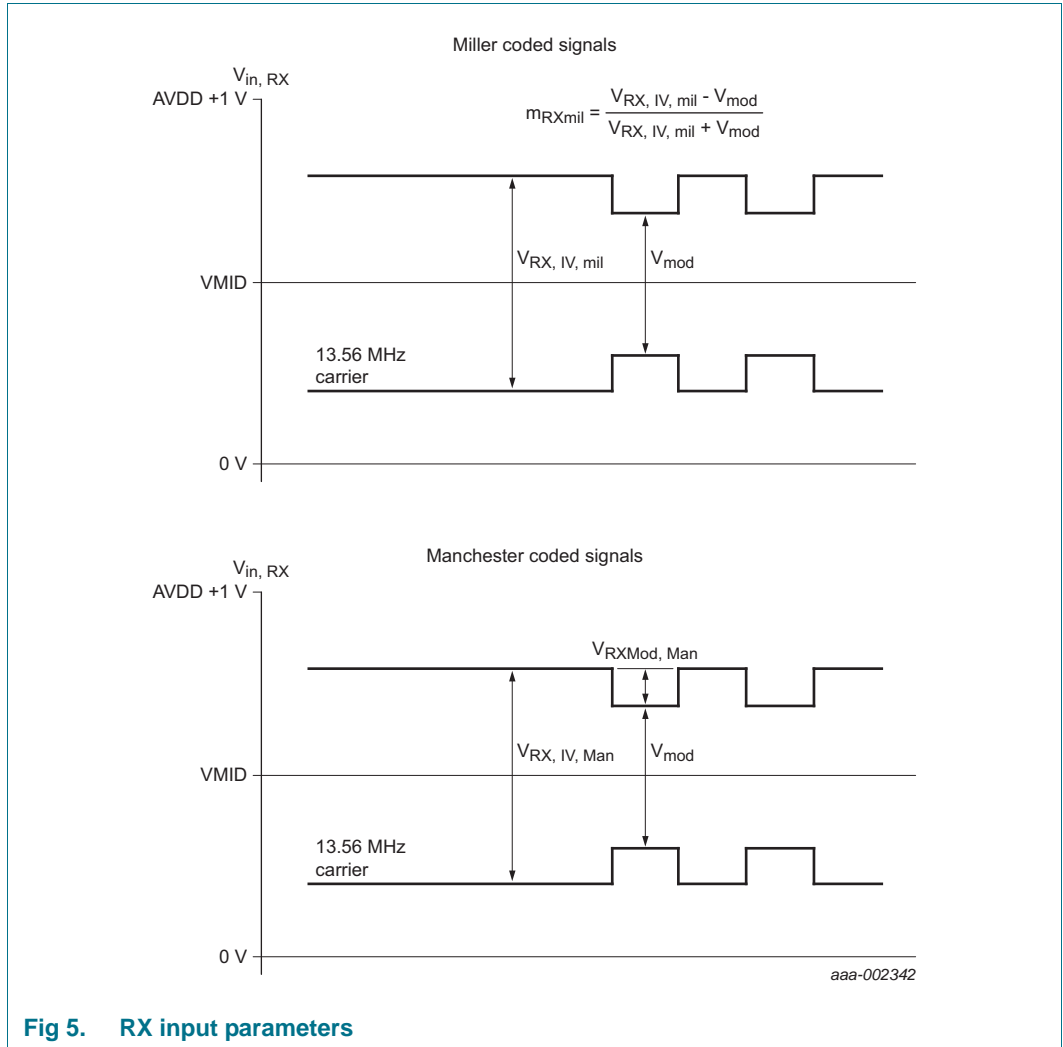

Fig 5. RX input parameters

Table 30. Input pin characteristics for RX

Symbol	Parameter	Conditions	Min	Typ	Max	Unit
V _i	input voltage	dynamic; signal frequency at 13.56 MHz	-0.7		V _{DDA} +1	V
C _i	input capacitance		6	10	14	pF
R _s	series resistance	RX input; V _{DDA} = 3 V; receiver active; V _{RX(p-p)} = 1 V; 1.5 V DC offset	315	350	385	Ω
Minimum dynamic input voltage						

Table 30. Input pin characteristics for RX ...continued

Symbol	Parameter	Conditions	Min	Typ	Max	Unit
$V_{RX(p-p)}$	peak-to-peak receiver voltage	Miller coded; 106 kbit/s	-	150	500	mV
		Manchester coded; 212 kbit/s and 424 kbit/s	-	100	200	mV
Maximum dynamic input voltage						
$V_{RX(p-p)}$	peak-to-peak receiver voltage	Miller coded; 106 kbit/s	V_{DDA}	-	-	V
		Manchester coded; 212 and 424 kbit/s	V_{DDA}	-	-	V
Minimum modulation voltage						
V_{mod}	modulation voltage	RxGain = 6 and 7 [1]	-	-	6	mV
		RxGain = 4 and 5 [1]	-	-	18	mV
		RxGain = 0 to 3 [1]	-	-	120	mV
Minimum modulation index						
m	modulation index	Miller coded; 106 kbit/s $V_{RX(p-p)} = 1.5$ V; SensMiller = 3	-	33	-	%

[1] The minimum modulation voltage is valid for all modulation schemes except Miller coded signals.

10.20 Output pin characteristics for AUX1/AUX2

Table 31. Output pin characteristics for AUX1/AUX2

Symbol	Parameter	Conditions	Min	Typ	Max	Unit
V_{OH}	HIGH-level output voltage	$V_{DDD} = 3$ V; $I_{OH} = -4$ mA	$V_{DDD} - 0.4$	-	V_{DDD}	V
V_{OL}	LOW-level output voltage	$V_{DDD} = 3$ V; $I_{OL} = 4$ mA	V_{SSD}	-	$V_{SSD} + 0.4$	V
I_{OH}	HIGH-level output current	$V_{DDD} = 3$ V; $V_{OH} = V_{DDD} - 0.3$	-4	-	-	mA
I_{OL}	LOW-level output current	$V_{DDD} = 3$ V; $V_{OL} = V_{DDD} - 0.3$	4	-	-	mA
I_{LI}	input leakage current	RSTPD_N = 0 V	-1	-	+1	μ A
C_i	input capacitance		-	2.5	-	pF
C_L	load capacitance		-	-	15	pF

10.21 Output pin characteristics for TX1/TX2

Table 32. Output pin characteristics for TX1/TX2

Symbol	Parameter	Conditions	Min	Typ	Max	Unit
V _{OH}	HIGH-level output voltage	V _{DD(TVDD)} = 3 V; I _O = 32 mA; CWGsN = Fh	-	-	150	mV
		V _{DD(TVDD)} = 3 V; I _O = 80 mA; CWGsN = Fh	-	-	400	mV
V _{OL}	LOW-level output voltage	V _{DD(TVDD)} = 2.5 V; I _O = 32 mA; CWGsN = Fh	-	-	240	mV
		V _{DD(TVDD)} = 2.5 V; I _O = 80 mA; CWGsN = Fh	-	-	640	mV

Table 33. Output resistance for TX1/TX2

Symbol	Parameter	Conditions ¹	CWGsP	Min	Typ	Max	Unit
R _{OH}	HIGH-level output resistance	V _{DD(TVDD)} = 3 V; V _O = V _{DD(TVDD)} - 100 mV	01h	133	180	251	Ω
			02h	67	90	125	Ω
			04h	34	46	62	Ω
			08h	17	23	31	Ω
			10h	8.5	12	15.5	Ω
			20h	4.7	6	7.8	Ω
			3Fh	2.3	3	4.4	Ω
R _{OL}	LOW-level output resistance		10h	34	46	62	Ω
			20h	17	23	31	Ω
			40h	8.5	12	15.5	Ω
			80h	4.7	6	7.8	Ω
			F0h	2.3	3	4.4	Ω

10.22 System reset timing

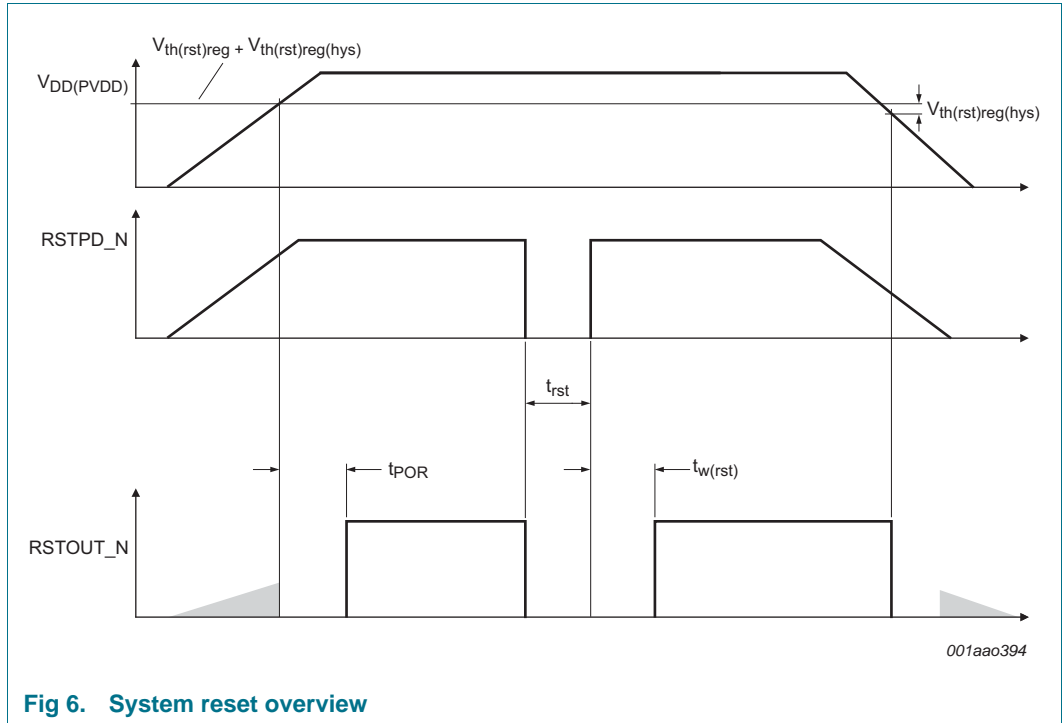

Fig 6. System reset overview

Table 34. Reset duration time

Symbol	Parameter	Conditions	Min	Typ	Max	Unit
t_{POR}	power-on reset time		[1] 0.1	0.4	2	ms
t_{rst}	reset time	hard power-down time; user dependent	[2] 20	-	-	ns
$t_{w(rst)}$	reset pulse width	reset time when RSTPD_N is released	[1] 0.1	0.4	2	ms

[1] Dependent on the 27.12 MHz crystal oscillator startup time.

[2] If the t_{rst} pulse is shorter than 20 ns, the device may be only partially reset.

10.23 Timing for the I²C-bus interface

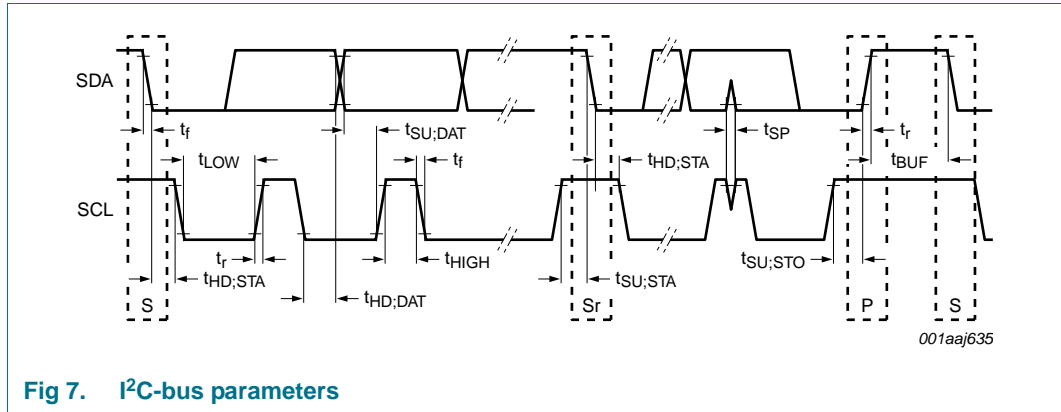

Fig 7. I²C-bus parameters

Table 35. I²C-bus timing specification

Symbol	Parameter	Conditions	Min	Typ	Max	Unit
f_{SCL}	SCL clock frequency		0	-	400	kHz
$t_{HD;STA}$	hold time (repeated) START condition	after this period, the first clock pulse is generated	600	-	-	ns
$t_{SU;STA}$	set-up time for a repeated START condition		600	-	-	ns
$t_{SU;STO}$	set-up time for STOP condition		600	-	-	ns
t_{LOW}	LOW period of the SCL clock	P50_SCL	1300	-	-	ns
t_{HIGH}	HIGH period of the SCL clock	P50_SCL	600	-	-	ns
$t_{HD;DAT}$	data hold time		0	-	900	ns
$t_{SU;DAT}$	data set-up time		100	-	-	ns
t_r	rise time of both SDA and SCL signals	P50_SCL	[1] 20	-	300	ns
t_f	fall time of both SDA and SCL signals	P50_SCL	[1] 20	-	300	ns
t_{BUF}	bus free time between a STOP and START condition		1.3	-	-	ms
$t_{stretch}$	stretch time	stretching time on P50_SCL when woken-up on its own address	[2] -	-	1	ms
t_h	hold time	internal for SDA	330	-	590	ns
		internal for SDA in [3] SPD mode	-	270	-	ns

[1] The PR533 has a slope control according to the I²C-bus specification for the Fast mode. The slope control is always present and not dependent of the I²C-bus speed.

[2] 27.12 MHz quartz starts in less than 800 μ s. For example, quartz like TAS-3225A, TAS-7 or KSS2F with appropriate layout.

[3] The PR533 has an internal hold time of around 270 ns for the SDA signal to bridge the undefined region of the falling edge of P50_SCL.

10.24 Temperature sensor

Table 36. Temperature sensor characteristics

Symbol	Parameter	Conditions	Min	Typ	Max	Unit
$T_{th(act)otp}$	overtemperature protection activation threshold temperature	CIU [1]	100	125	140	°C

- [1] The temperature sensor embedded in the PR533 is not intended to monitor the temperature. Its purpose is to prevent destruction of the IC due to excessive heat. The external application should include circuitry to ensure that the ambient temperature does not exceed 85 °C as specified in [Table 5 "Operating conditions"](#).

11. Application information

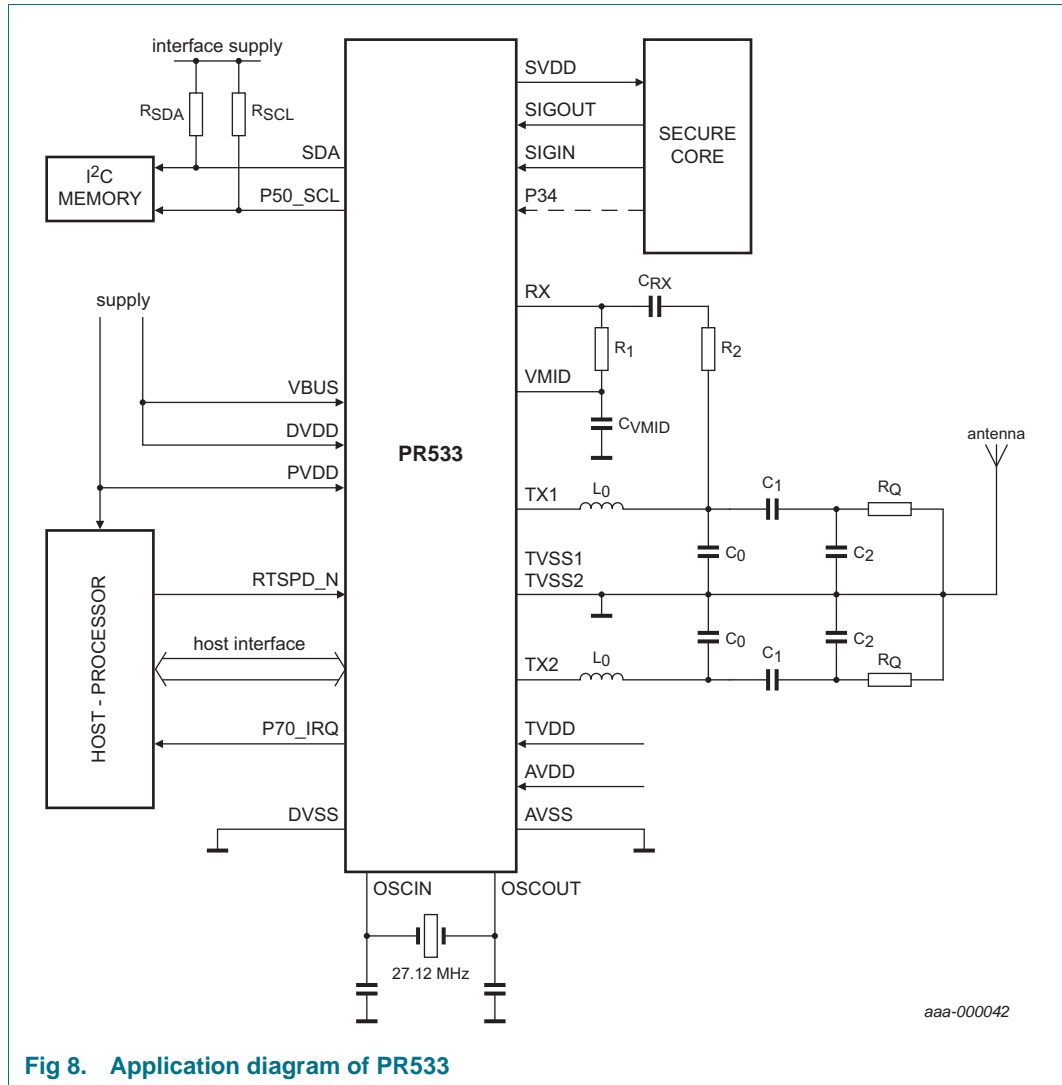

Fig 8. Application diagram of PR533

12. Abbreviations

Table 37. Abbreviations

Acronym	Description
CDM	Charge device Body Model
CRC	Cyclic Redundancy Check
EEPROM	Electrically Erasable Programmable Read-Only Memory
HBM	Human Body Model
HPD	Hard Power Down
MM	Machine Model
NFC	Near Field Communication
SPD	Soft Power Down mode

13. Revision history

Table 38. Revision history

Document ID	Release date	Data sheet status	Change notice	Supersedes
PR533_SDS v.3.6	20141027	Product short data sheet	-	PR533_SDS v.3.5
Modifications:	<ul style="list-style-type: none"> • Section 1.2 "Interfaces": updated 			
PR533_SDS v.3.5 ^[1]	20141003	Product short data sheet	-	PR533_SDS v.3.4
Modifications:	<ul style="list-style-type: none"> • Template updated. • Descriptive title updated. • Alternative descriptive title updated. 			
PR533_SDS v.3.3	20121020	Product short data sheet	-	PR533_SDS v.3.2
Modifications:	<ul style="list-style-type: none"> • Section 14.4 "Licenses": updated 			
PR533_SDS v.3.2	20120306	Product short data sheet	-	PR5331C3HN_SDS v.3.0
Modifications:	<ul style="list-style-type: none"> • Section 4 "Ordering information": updated • General update to comply full data sheet 			
PR5331C3HN_SDS v.3.0	20110803	Product short data sheet	-	-

[1] Revision 3.4 is not available.

14. Legal information

14.1 Data sheet status

Document status ^{[1][2]}	Product status ^[3]	Definition
Objective [short] data sheet	Development	This document contains data from the objective specification for product development.
Preliminary [short] data sheet	Qualification	This document contains data from the preliminary specification.
Product [short] data sheet	Production	This document contains the product specification.

[1] Please consult the most recently issued document before initiating or completing a design.

[2] The term 'short data sheet' is explained in section "Definitions".

[3] The product status of device(s) described in this document may have changed since this document was published and may differ in case of multiple devices. The latest product status information is available on the Internet at URL <http://www.nxp.com>.

14.2 Definitions

Draft — The document is a draft version only. The content is still under internal review and subject to formal approval, which may result in modifications or additions. NXP Semiconductors does not give any representations or warranties as to the accuracy or completeness of information included herein and shall have no liability for the consequences of use of such information.

Short data sheet — A short data sheet is an extract from a full data sheet with the same product type number(s) and title. A short data sheet is intended for quick reference only and should not be relied upon to contain detailed and full information. For detailed and full information see the relevant full data sheet, which is available on request via the local NXP Semiconductors sales office. In case of any inconsistency or conflict with the short data sheet, the full data sheet shall prevail.

Product specification — The information and data provided in a Product data sheet shall define the specification of the product as agreed between NXP Semiconductors and its customer, unless NXP Semiconductors and customer have explicitly agreed otherwise in writing. In no event however, shall an agreement be valid in which the NXP Semiconductors product is deemed to offer functions and qualities beyond those described in the Product data sheet.

14.3 Disclaimers

Limited warranty and liability — Information in this document is believed to be accurate and reliable. However, NXP Semiconductors does not give any representations or warranties, expressed or implied, as to the accuracy or completeness of such information and shall have no liability for the consequences of use of such information. NXP Semiconductors takes no responsibility for the content in this document if provided by an information source outside of NXP Semiconductors.

In no event shall NXP Semiconductors be liable for any indirect, incidental, punitive, special or consequential damages (including - without limitation - lost profits, lost savings, business interruption, costs related to the removal or replacement of any products or rework charges) whether or not such damages are based on tort (including negligence), warranty, breach of contract or any other legal theory.

Notwithstanding any damages that customer might incur for any reason whatsoever, NXP Semiconductors' aggregate and cumulative liability towards customer for the products described herein shall be limited in accordance with the *Terms and conditions of commercial sale* of NXP Semiconductors.

Right to make changes — NXP Semiconductors reserves the right to make changes to information published in this document, including without limitation specifications and product descriptions, at any time and without notice. This document supersedes and replaces all information supplied prior to the publication hereof.

Suitability for use — NXP Semiconductors products are not designed, authorized or warranted to be suitable for use in life support, life-critical or safety-critical systems or equipment, nor in applications where failure or malfunction of an NXP Semiconductors product can reasonably be expected to result in personal injury, death or severe property or environmental damage. NXP Semiconductors and its suppliers accept no liability for inclusion and/or use of NXP Semiconductors products in such equipment or applications and therefore such inclusion and/or use is at the customer's own risk.

Applications — Applications that are described herein for any of these products are for illustrative purposes only. NXP Semiconductors makes no representation or warranty that such applications will be suitable for the specified use without further testing or modification.

Customers are responsible for the design and operation of their applications and products using NXP Semiconductors products, and NXP Semiconductors accepts no liability for any assistance with applications or customer product design. It is customer's sole responsibility to determine whether the NXP Semiconductors product is suitable and fit for the customer's applications and products planned, as well as for the planned application and use of customer's third party customer(s). Customers should provide appropriate design and operating safeguards to minimize the risks associated with their applications and products.

NXP Semiconductors does not accept any liability related to any default, damage, costs or problem which is based on any weakness or default in the customer's applications or products, or the application or use by customer's third party customer(s). Customer is responsible for doing all necessary testing for the customer's applications and products using NXP Semiconductors products in order to avoid a default of the applications and the products or of the application or use by customer's third party customer(s). NXP does not accept any liability in this respect.

Limiting values — Stress above one or more limiting values (as defined in the Absolute Maximum Ratings System of IEC 60134) will cause permanent damage to the device. Limiting values are stress ratings only and (proper) operation of the device at these or any other conditions above those given in the Recommended operating conditions section (if present) or the Characteristics sections of this document is not warranted. Constant or repeated exposure to limiting values will permanently and irreversibly affect the quality and reliability of the device.

Terms and conditions of commercial sale — NXP Semiconductors products are sold subject to the general terms and conditions of commercial sale, as published at <http://www.nxp.com/profile/terms>, unless otherwise agreed in a valid written individual agreement. In case an individual agreement is concluded only the terms and conditions of the respective agreement shall apply. NXP Semiconductors hereby expressly objects to applying the customer's general terms and conditions with regard to the purchase of NXP Semiconductors products by customer.

No offer to sell or license — Nothing in this document may be interpreted or construed as an offer to sell products that is open for acceptance or the grant, conveyance or implication of any license under any copyrights, patents or other industrial or intellectual property rights.

Export control — This document as well as the item(s) described herein may be subject to export control regulations. Export might require a prior authorization from competent authorities.

Quick reference data — The Quick reference data is an extract of the product data given in the Limiting values and Characteristics sections of this document, and as such is not complete, exhaustive or legally binding.

Non-automotive qualified products — Unless this data sheet expressly states that this specific NXP Semiconductors product is automotive qualified, the product is not suitable for automotive use. It is neither qualified nor tested in accordance with automotive testing or application requirements. NXP Semiconductors accepts no liability for inclusion and/or use of non-automotive qualified products in automotive equipment or applications.

In the event that customer uses the product for design-in and use in automotive applications to automotive specifications and standards, customer (a) shall use the product without NXP Semiconductors' warranty of the product for such automotive applications, use and specifications, and (b) whenever customer uses the product for automotive applications beyond NXP Semiconductors' specifications such use shall be solely at customer's own risk, and (c) customer fully indemnifies NXP Semiconductors for any liability, damages or failed product claims resulting from customer design and use of the product for automotive applications beyond NXP Semiconductors' standard warranty and NXP Semiconductors' product specifications.

Translations — A non-English (translated) version of a document is for reference only. The English version shall prevail in case of any discrepancy between the translated and English versions.

15. Contact information

For more information, please visit: <http://www.nxp.com>

For sales office addresses, please send an email to: salesaddresses@nxp.com

14.4 Licenses

Purchase of NXP ICs with ISO/IEC 14443 type B functionality



This NXP Semiconductors IC is ISO/IEC 14443 Type B software enabled and is licensed under Innovatron's Contactless Card patents license for ISO/IEC 14443 B. The license includes the right to use the IC in systems and/or end-user equipment.

RATP/Innovatron Technology

Purchase of NXP ICs with NFC technology

Purchase of an NXP Semiconductors IC that complies with one of the Near Field Communication (NFC) standards ISO/IEC 18092 and ISO/IEC 21481 does not convey an implied license under any patent right infringed by implementation of any of those standards.

14.5 Trademarks

Notice: All referenced brands, product names, service names and trademarks are the property of their respective owners.

MIFARE — is a trademark of NXP Semiconductors N.V.

IC-bus — logo is a trademark of NXP Semiconductors N.V.

Notes

16. Tables

Table 1.	Quick reference data	3
Table 2.	Ordering information	4
Table 3.	PR533 pin description	5
Table 4.	Limiting values	7
Table 5.	Operating conditions	8
Table 6.	Thermal characteristics	8
Table 7.	Current consumption characteristics	9
Table 8.	Voltage regulator characteristics ^[1]	9
Table 9.	Antenna presence detection	10
Table 10.	Crystal requirements	11
Table 11.	Pin characteristics for 27.12 MHz XTAL Oscillator (OSCIN, OSCOUT)	11
Table 12.	RSTPD_N input pin characteristics	12
Table 13.	Input pin characteristics for I0, I1 and TESTEN	12
Table 14.	RSTOUT_N output pin characteristics	13
Table 15.	Input/output pin characteristics for pin P70_IRQ	14
Table 16.	Input/output pin characteristics for P30 / UART_RX, P31 / UART_TX, P32_INT0, P33_INT1	15
Table 17.	Input/output pin characteristics for P35	16
Table 18.	Input/output pin characteristics for DP and DM for USB interface	17
Table 19.	USB DP/DM differential receiver input levels	18
Table 20.	USB DP/DM driver characteristics	18
Table 21.	Input Pin characteristics for DP for HSU interface	19
Table 22.	Output Pin characteristics for DM for HSU interface	19
Table 23.	Input/output drain output pin characteristics for SCL I ² C interface	20
Table 24.	Input/output drain output pin characteristics for SDA I ² C interface	20
Table 25.	Output pin characteristics for DELATT	21
Table 26.	Input/output pin characteristics for SIGIN	21
Table 27.	Output pin characteristics for SIGOUT	21
Table 28.	Input/output pin characteristics for P34	22
Table 29.	Output pin characteristics for LOADMOD	22
Table 30.	Input pin characteristics for RX	23
Table 31.	Output pin characteristics for AUX1/AUX2	24
Table 32.	Output pin characteristics for TX1/TX2	25
Table 33.	Output resistance for TX1/TX2	25
Table 34.	Reset duration time	26
Table 35.	I ² C-bus timing specification	27
Table 36.	Temperature sensor characteristics	28
Table 37.	Abbreviations	29
Table 38.	Revision history	30

17. Figures

Fig 1.	Block diagram	4
Fig 2.	Pin configuration for HVQFN 40 (SOT618-1)	5
Fig 3.	27.12 MHz input clock phase noise spectrum mask	11
Fig 4.	Transmit waveform at DP/DM	18
Fig 5.	RX input parameters	23
Fig 6.	System reset overview.....	26
Fig 7.	I ² C-bus parameters	27
Fig 8.	Application diagram of PR533.....	29

18. Contents

1	General description	1	11	Application information	29
1.1	RF protocols	1	12	Abbreviations	29
1.2	Interfaces	1	13	Revision history	30
1.3	Standards compliancy	1	14	Legal information	31
1.4	Supported operating systems	2	14.1	Data sheet status	31
2	Features and benefits	2	14.2	Definitions	31
3	Quick reference data	3	14.3	Disclaimers	31
4	Ordering information	4	14.4	Licenses	32
5	Block diagram	4	14.5	Trademarks	32
6	Pinning information	5	15	Contact information	32
6.1	Pinning	5	16	Tables	34
6.2	Pin description	5	17	Figures	35
7	Limiting values	7	18	Contents	36
8	Recommended operating conditions	8			
9	Thermal characteristics	8			
10	Characteristics	8			
10.1	Power management characteristics	8			
10.1.1	Current consumption characteristics	8			
10.1.2	Voltage regulator characteristics	9			
10.2	Antenna presence self test thresholds	9			
10.3	Typical 27.12 MHz Crystal requirements	11			
10.4	Pin characteristics for 27.12 MHz XTAL Oscillator (OSCIN, OSCOUT)	11			
10.5	RSTPD_N input pin characteristics	12			
10.6	Input pin characteristics for I0, I1 and TESTEN	12			
10.7	RSTOUT_N output pin characteristics	13			
10.8	Input/output characteristics for pin P70_IRQ	14			
10.9	Input/output pin characteristics for P30 / UART_RX, P31 / UART_TX, P32_INT0, P33_INT1	15			
10.10	Input/output pin characteristics for P35	16			
10.11	Input/output pin characteristics for DP and DM	17			
10.12	Input pin characteristics for SCL	20			
10.13	Input/output pin characteristics for SDA	20			
10.14	Output pin characteristics for DELATT	21			
10.15	Input pin characteristics for SIGIN	21			
10.16	Output pin characteristics for SIGOUT	21			
10.17	Input/output pin characteristics for P34	22			
10.18	Output pin characteristics for LOADMOD	22			
10.19	Input pin characteristics for RX	23			
10.20	Output pin characteristics for AUX1/AUX2	24			
10.21	Output pin characteristics for TX1/TX2	25			
10.22	System reset timing	26			
10.23	Timing for the I ² C-bus interface	27			
10.24	Temperature sensor	28			

Please be aware that important notices concerning this document and the product(s) described herein, have been included in section 'Legal information'.

© NXP Semiconductors N.V. 2014.

All rights reserved.



For more information, please visit: <http://www.nxp.com>

For sales office addresses, please send an email to: salesaddresses@nxp.com

Date of release: 27 October 2014
206436

Looking for pricing, stock, or lifecycle information?

Click below to explore more details on WIN SOURCE:

-  [View PR5331C3HN/C350,51 on WIN SOURCE](#)
-  [NXP / Nexperia Information](#)

Optimize Your Supply Chain with WIN SOURCE Solutions

-  Global Sourcing Solution
-  Obsolete Management
-  Cost Control Management
-  Shortage Management
-  Alternative Solution
-  Excess Inventory Management