



# **PIC16F716**

## **Data Sheet**

8-bit Flash-based Microcontroller  
with A/D Converter and  
Enhanced Capture/Compare/PWM

---

---

**Note the following details of the code protection feature on Microchip devices:**

- Microchip products meet the specification contained in their particular Microchip Data Sheet.
- Microchip believes that its family of products is one of the most secure families of its kind on the market today, when used in the intended manner and under normal conditions.
- There are dishonest and possibly illegal methods used to breach the code protection feature. All of these methods, to our knowledge, require using the Microchip products in a manner outside the operating specifications contained in Microchip's Data Sheets. Most likely, the person doing so is engaged in theft of intellectual property.
- Microchip is willing to work with the customer who is concerned about the integrity of their code.
- Neither Microchip nor any other semiconductor manufacturer can guarantee the security of their code. Code protection does not mean that we are guaranteeing the product as "unbreakable."

Code protection is constantly evolving. We at Microchip are committed to continuously improving the code protection features of our products. Attempts to break Microchip's code protection feature may be a violation of the Digital Millennium Copyright Act. If such acts allow unauthorized access to your software or other copyrighted work, you may have a right to sue for relief under that Act.

---

Information contained in this publication regarding device applications and the like is provided only for your convenience and may be superseded by updates. It is your responsibility to ensure that your application meets with your specifications. MICROCHIP MAKES NO REPRESENTATIONS OR WARRANTIES OF ANY KIND WHETHER EXPRESS OR IMPLIED, WRITTEN OR ORAL, STATUTORY OR OTHERWISE, RELATED TO THE INFORMATION, INCLUDING BUT NOT LIMITED TO ITS CONDITION, QUALITY, PERFORMANCE, MERCHANTABILITY OR FITNESS FOR PURPOSE. Microchip disclaims all liability arising from this information and its use. Use of Microchip devices in life support and/or safety applications is entirely at the buyer's risk, and the buyer agrees to defend, indemnify and hold harmless Microchip from any and all damages, claims, suits, or expenses resulting from such use. No licenses are conveyed, implicitly or otherwise, under any Microchip intellectual property rights.

**Trademarks**

The Microchip name and logo, the Microchip logo, Accuron, dsPIC, KEELOQ, KEELOQ logo, microID, MPLAB, PIC, PICmicro, PICSTART, PRO MATE, PowerSmart, rfPIC, and SmartShunt are registered trademarks of Microchip Technology Incorporated in the U.S.A. and other countries.


AmpLab, FilterLab, Linear Active Thermistor, Migratable Memory, MXDEV, MXLAB, PS logo, SEEVAL, SmartSensor and The Embedded Control Solutions Company are registered trademarks of Microchip Technology Incorporated in the U.S.A.

Analog-for-the-Digital Age, Application Maestro, CodeGuard, dsPICDEM, dsPICDEM.net, dsPICworks, ECAN, ECONOMONITOR, FanSense, FlexROM, fuzzyLAB, In-Circuit Serial Programming, ICSP, ICEPIC, Mindi, MiWi, MPASM, MPLAB Certified logo, MPLIB, MPLINK, PICkit, PICDEM, PICDEM.net, PICLAB, PICtail, PowerCal, PowerInfo, PowerMate, PowerTool, REAL ICE, rLAB, rfPICDEM, Select Mode, Smart Serial, SmartTel, Total Endurance, UNI/O, WiperLock and ZENA are trademarks of Microchip Technology Incorporated in the U.S.A. and other countries.

SQTP is a service mark of Microchip Technology Incorporated in the U.S.A.

All other trademarks mentioned herein are property of their respective companies.

© 2007, Microchip Technology Incorporated, Printed in the U.S.A., All Rights Reserved.

 Printed on recycled paper.

*Microchip received ISO/TS-16949:2002 certification for its worldwide headquarters, design and wafer fabrication facilities in Chandler and Tempe, Arizona, Gresham, Oregon and Mountain View, California. The Company's quality system processes and procedures are for its PIC<sup>®</sup> MCUs and dsPIC<sup>®</sup> DSCs, KEELOQ<sup>®</sup> code hopping devices, Serial EEPROMs, microperipherals, nonvolatile memory and analog products. In addition, Microchip's quality system for the design and manufacture of development systems is ISO 9001:2000 certified.*

**QUALITY MANAGEMENT SYSTEM  
CERTIFIED BY DNV  
== ISO/TS 16949:2002 ==**



# PIC16F716

## 8-bit Flash-based Microcontroller with A/D Controller and Enhanced Capture/Compare PWM

### Microcontroller Core Features:

- High-performance RISC CPU
- Only 35 single-word instructions to learn
  - All single-cycle instructions except for program branches which are two-cycle
- Operating speed: DC – 20 MHz clock input  
DC – 200 ns instruction cycle
- Interrupt capability  
(up to 7 internal/external interrupt sources)
- 8-level deep hardware stack
- Direct, Indirect and Relative Addressing modes

### Special Microcontroller Features:

- Power-on Reset (POR)
- Power-up Timer (PWRT) and Oscillator Start-up Timer (OST)
- Watchdog Timer (WDT) with its own on-chip RC oscillator for reliable operation
- Dual level Brown-out Reset circuitry
  - 2.5 V<sub>BOR</sub> (Typical)
  - 4.0 V<sub>BOR</sub> (Typical)
- Programmable code protection
- Power-Saving Sleep mode
- Selectable oscillator options
- Fully static design
- In-Circuit Serial Programming™ (ICSP™)

### CMOS Technology:

- Wide operating voltage range:
  - Industrial: 2.0V to 5.5V
  - Extended: 3.0V to 5.5V
- High Sink/Source Current 25/25 mA
- Wide temperature range:
  - Industrial: -40°C to 85°C
  - Extended: -40°C to 125°C

### Low-Power Features:

- Standby Current:
  - 100 nA @ 2.0V, typical
- Operating Current:
  - 14 µA @ 32 kHz, 2.0V, typical
  - 120 µA @ 1 MHz, 2.0V, typical
- Watchdog Timer Circuit:
  - 1 µA @ 2.0V, typical
- Timer1 Oscillator Current:
  - 3.0 µA @ 32 kHz, 2.0V, typical

### Peripheral Features:

- Timer0: 8-bit timer/counter with 8-bit prescaler
- Timer1: 16-bit timer/counter with prescaler can be incremented during Sleep via external crystal/clock
- Timer2: 8-bit timer/counter with 8-bit period register, prescaler and postscaler
- Enhanced Capture, Compare, PWM module:
  - Capture is 16-bit, max. resolution is 12.5 ns
  - Compare is 16-bit, max. resolution is 200 ns
  - PWM maximum resolution is 10-bit
  - Enhanced PWM:
    - Single, Half-Bridge and Full-Bridge modes
    - Digitally programmable dead-band delay
    - Auto-shutdown/restart
- 8-bit multi-channel Analog-to-Digital Converter
- 13 I/O pins with individual direction control
- Programmable weak pull-ups on PORTB

Device	Memory		I/O	8-bit A/D (ch)	Timers 8/16	PWM (outputs)	V <sub>DD</sub> Range
	Flash	Data					
PIC16F716	2048 x 14	128 x 8	13	4	2/1	1/2/4	2.0V-5.5V

# PIC16F716

## 18-Pin Diagram

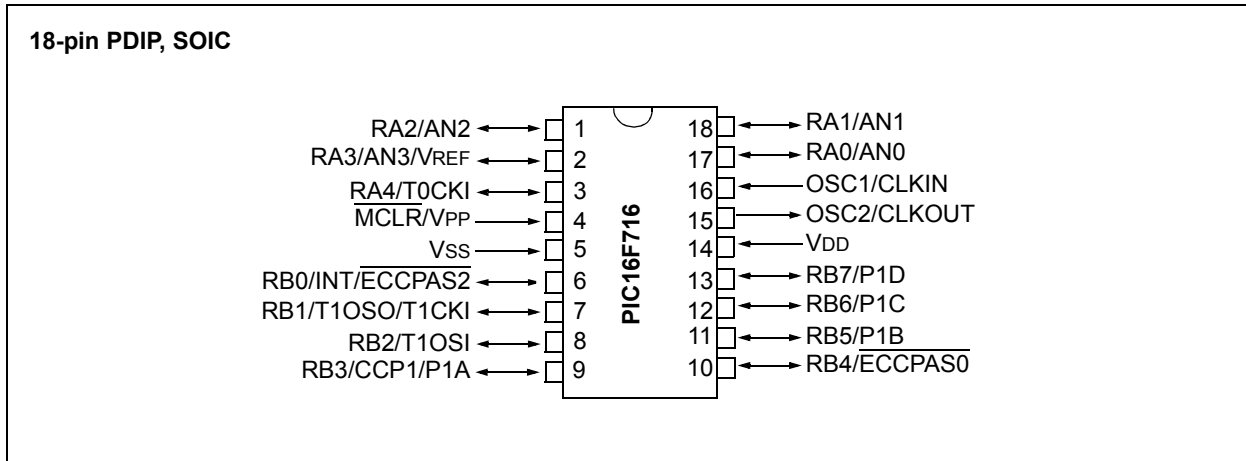
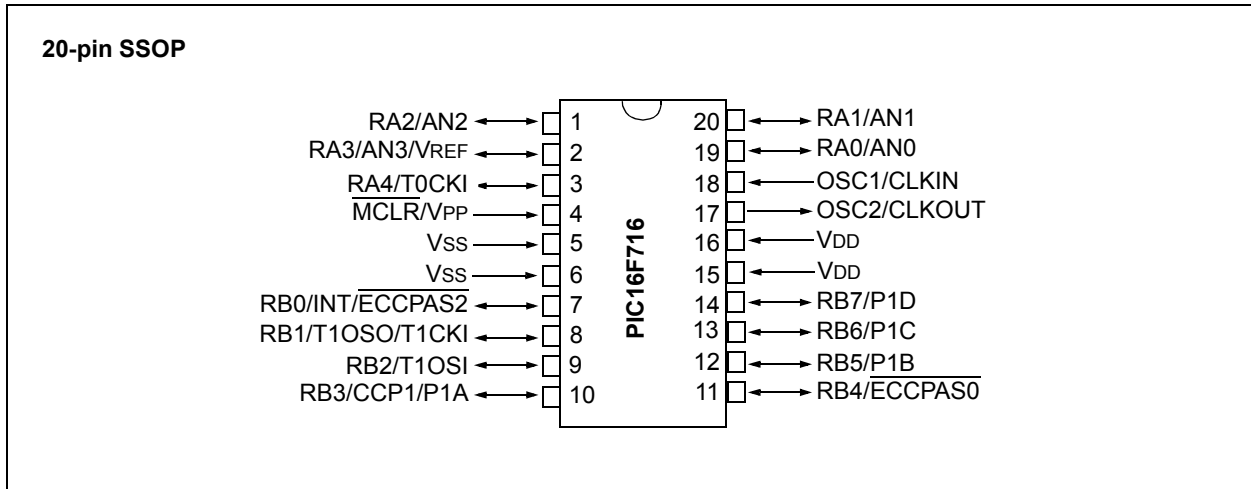


TABLE 1: 18-PIN PDIP, SOIC SUMMARY

I/O	Pin	Analog	ECCP	Timer	Interrupts	Pull-ups	Basic
RA0	17	AN0	—	—	—	—	—
RA1	18	AN1	—	—	—	—	—
RA2	1	AN2	—	—	—	—	—
RA3	2	AN3/VREF	—	—	—	—	—
RA4	3	—	—	T0CKI	—	—	—
RB0	6	—	ECCPAS2	—	INT	Y	—
RB1	7	—	—	T1CKI	—	Y	—
RB2	8	—	—	T1OSI	—	Y	—
RB3	9	—	CCP1/P1A	—	—	Y	—
RB4	10	—	ECCPAS0	—	IOC	Y	—
RB5	11	—	P1B	—	IOC	Y	—
RB6	12	—	P1C	—	IOC	Y	ICSPCLK
RB7	13	—	P1D	—	IOC	Y	ICSPDAT
—	14	—	—	—	—	—	VDD
—	5	—	—	—	—	—	Vss
—	4	—	—	—	—	—	MCLR/VPP
—	16	—	—	—	—	—	OSC1/CLKIN
—	15	—	—	—	—	—	OSC2/CLKOUT

## 20-Pin Diagram



**TABLE 2: 20-PIN SSOP SUMMARY**

I/O	Pin	Analog	ECCP	Timer	Interrupts	Pull-ups	Basic
RA0	19	AN0	—	—	—	—	—
RA1	20	AN1	—	—	—	—	—
RA2	1	AN2	—	—	—	—	—
RA3	2	AN3/VREF	—	—	—	—	—
RA4	3	—	—	T0CKI	—	—	—
RB0	7	—	ECCPAS2	—	INT	Y	—
RB1	8	—	—	T1CKI	—	Y	—
RB2	9	—	—	T1OSI	—	Y	—
RB3	10	—	CCP1/P1A	—	—	Y	—
RB4	11	—	ECCPAS0	—	IOC	Y	—
RB5	12	—	P1B	—	IOC	Y	—
RB6	13	—	P1C	—	IOC	Y	ICSPCLK
RB7	14	—	P1D	—	IOC	Y	ICSPDAT
—	15	—	—	—	—	—	VDD
—	16	—	—	—	—	—	VDD
—	5	—	—	—	—	—	Vss
—	6	—	—	—	—	—	Vss
—	4	—	—	—	—	—	MCLR/VPP
—	18	—	—	—	—	—	OSC1/CLKIN
—	17	—	—	—	—	—	OSC2/CLKOUT

# PIC16F716

## Table of Contents

1.0	Device Overview .....	5
2.0	Memory Organization .....	7
3.0	I/O Ports .....	19
4.0	Timer0 Module .....	27
5.0	Timer1 Module with Gate Control.....	29
6.0	Timer2 Module .....	35
7.0	Analog-to-Digital Converter (ADC) Module .....	37
8.0	Enhanced Capture/Compare/PWM Module .....	47
9.0	Special Features of the CPU .....	61
10.0	Instruction Set Summary .....	77
11.0	Development Support .....	87
12.0	Electrical Characteristics .....	91
13.0	DC and AC Characteristics Graphs and Tables .....	107
14.0	Packaging Information.....	121
	Appendix A: Revision History.....	125
	Appendix B: Conversion Considerations.....	125
	Appendix C: Migration from Base-line to Mid-Range Devices .....	126
	The Microchip Web Site .....	127
	Customer Change Notification Service .....	127
	Customer Support .....	127
	Reader Response .....	128
	Index .....	129
	Product Identification System.....	133

## TO OUR VALUED CUSTOMERS

It is our intention to provide our valued customers with the best documentation possible to ensure successful use of your Microchip products. To this end, we will continue to improve our publications to better suit your needs. Our publications will be refined and enhanced as new volumes and updates are introduced.

If you have any questions or comments regarding this publication, please contact the Marketing Communications Department via E-mail at [docerrors@microchip.com](mailto:docerrors@microchip.com) or fax the **Reader Response Form** in the back of this data sheet to (480) 792-4150. We welcome your feedback.

### Most Current Data Sheet

To obtain the most up-to-date version of this data sheet, please register at our Worldwide Web site at:

<http://www.microchip.com>

You can determine the version of a data sheet by examining its literature number found on the bottom outside corner of any page. The last character of the literature number is the version number, (e.g., DS30000A is version A of document DS30000).

### Errata

An errata sheet, describing minor operational differences from the data sheet and recommended workarounds, may exist for current devices. As device/documentation issues become known to us, we will publish an errata sheet. The errata will specify the revision of silicon and revision of document to which it applies.

To determine if an errata sheet exists for a particular device, please check with one of the following:

- Microchip's Worldwide Web site; <http://www.microchip.com>
- Your local Microchip sales office (see last page)

When contacting a sales office, please specify which device, revision of silicon and data sheet (include literature number) you are using.

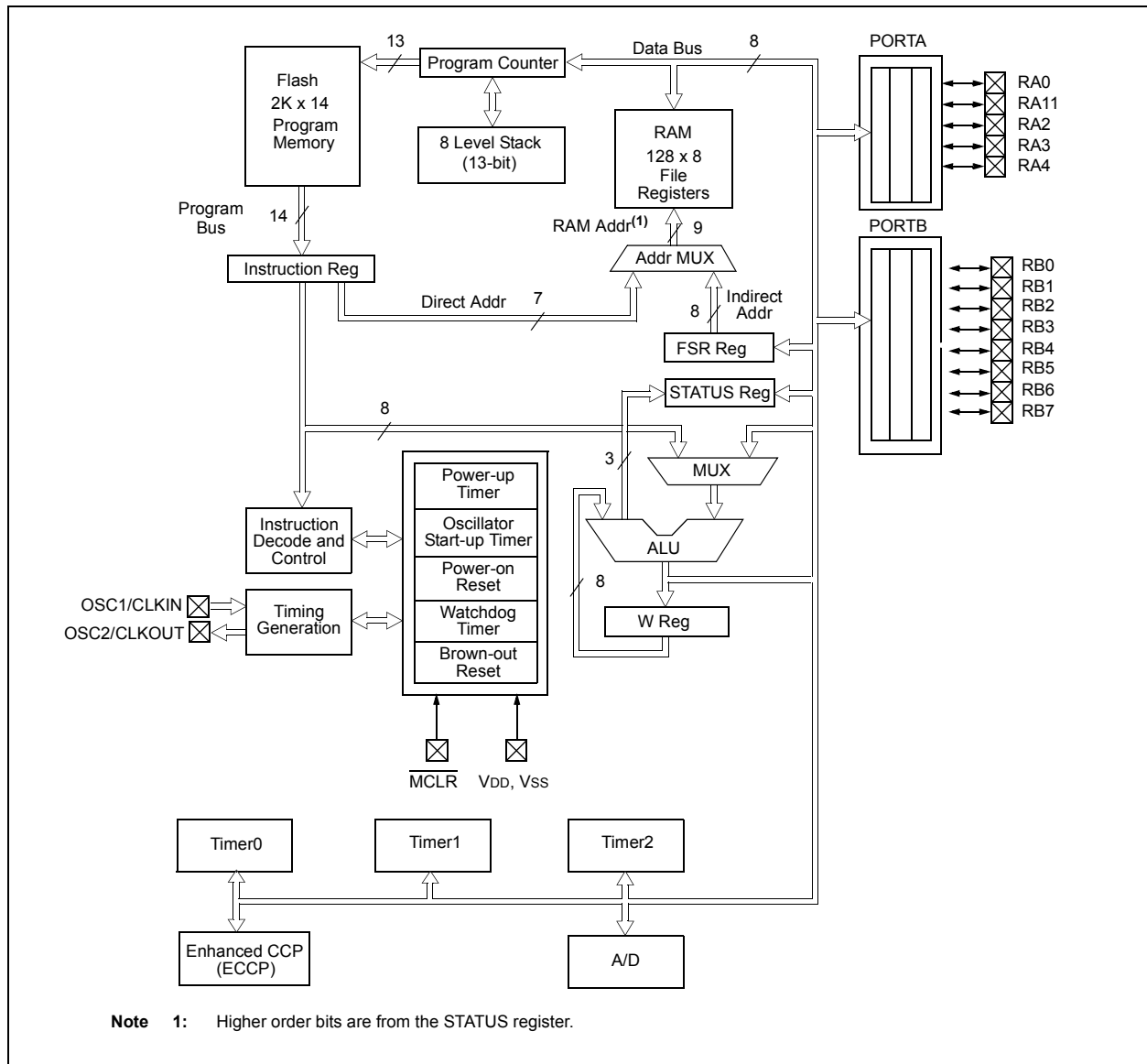
### Customer Notification System

Register on our web site at [www.microchip.com](http://www.microchip.com) to receive the most current information on all of our products.

## 1.0 DEVICE OVERVIEW

This document contains device specific information for the PIC16F716. Figure 1-1 is the block diagram for the PIC16F716 device. The pinouts are listed in Table 1-1.

**FIGURE 1-1: PIC16F716 BLOCK DIAGRAM**



# PIC16F716

**TABLE 1-1: PIC16F716 PINOUT DESCRIPTION**

Name	Function	Input Type	Output Type	Description
MCLR/VPP	MCLR	ST	—	Master clear (Reset) input. This pin is an active-low Reset to the device.
	VPP	P	—	Programming voltage input
OSC1/CLKIN	OSC1	XTAL	—	Oscillator crystal input
	CLKIN	CMOS	—	External clock source input
	CLKIN	ST	—	RC Oscillator mode
OSC2/CLKOUT	OSC2	XTAL	—	Oscillator crystal output. Connects to crystal or resonator in Crystal Oscillator mode.
	CLKOUT	—	CMOS	In RC mode, OSC2 pin outputs CLKOUT which has 1/4 the frequency of OSC1, and denotes the instruction cycle rate.
RA0/AN0	RA0	TTL	CMOS	Bidirectional I/O
	AN0	AN	—	Analog Channel 0 input
RA1/AN1	RA1	TTL	CMOS	Bidirectional I/O
	AN1	AN	—	Analog Channel 1 input
RA2/AN2	RA2	TTL	CMOS	Bidirectional I/O
	AN2	AN	—	Analog Channel 2 input
RA3/AN3/VREF	RA3	TTL	CMOS	Bidirectional I/O
	AN3	AN	—	Analog Channel 3 input
	VREF	AN	—	A/D reference voltage input
RA4/T0CKI	RA4	ST	OD	Bidirectional I/O. Open drain when configured as output.
	T0CKI	ST	—	Timer0 external clock input
RB0/INT/ECCPAS2	RB0	TTL	CMOS	Bidirectional I/O. Programmable weak pull-up.
	INT	ST	—	External Interrupt
	ECCPAS2	ST	—	ECCP Auto-Shutdown pin
RB1/T1OSO/T1CKI	RB1	TTL	CMOS	Bidirectional I/O. Programmable weak pull-up.
	T1OSO	—	XTAL	Timer1 oscillator output. Connects to crystal in Oscillator mode.
	T1CKI	ST	—	Timer1 external clock input
RB2/T1OSI	RB2	TTL	CMOS	Bidirectional I/O. Programmable weak pull-up.
	T1OSI	XTAL	—	Timer1 oscillator input. Connects to crystal in Oscillator mode.
RB3/CCP1/P1A	RB3	TTL	CMOS	Bidirectional I/O. Programmable weak pull-up.
	CCP1	ST	CMOS	Capture1 input, Compare1 output, PWM1 output.
	P1A	—	CMOS	PWM P1A output
RB4/ECCPAS0	RB4	TTL	CMOS	Bidirectional I/O. Programmable weak pull-up. Interrupt-on-change.
	ECCPAS0	ST	—	ECCP Auto-Shutdown pin
RB5/P1B	RB5	TTL	CMOS	Bidirectional I/O. Programmable weak pull-up. Interrupt-on-change.
	P1B	—	CMOS	PWM P1B output
RB6/P1C	RB6	TTL	CMOS	Bidirectional I/O. Programmable weak pull-up. Interrupt-on-change. ST input when used as ICSP programming clock.
	P1C	—	CMOS	PWM P1C output
RB7/P1D	RB7	TTL	CMOS	Bidirectional I/O. Programmable weak pull-up. Interrupt-on-change. ST input when used as ICSP programming data.
	P1D	—	CMOS	PWM P1D output
Vss	Vss	P	—	Ground reference for logic and I/O pins.
VDD	VDD	P	—	Positive supply for logic and I/O pins.

**Legend:** I = Input      AN = Analog input or output      OD = Open drain  
O = Output      TTL = TTL compatible input      ST = Schmitt Trigger input with CMOS levels  
P = Power      XTAL = Crystal      CMOS = CMOS compatible input or output

## 2.0 MEMORY ORGANIZATION

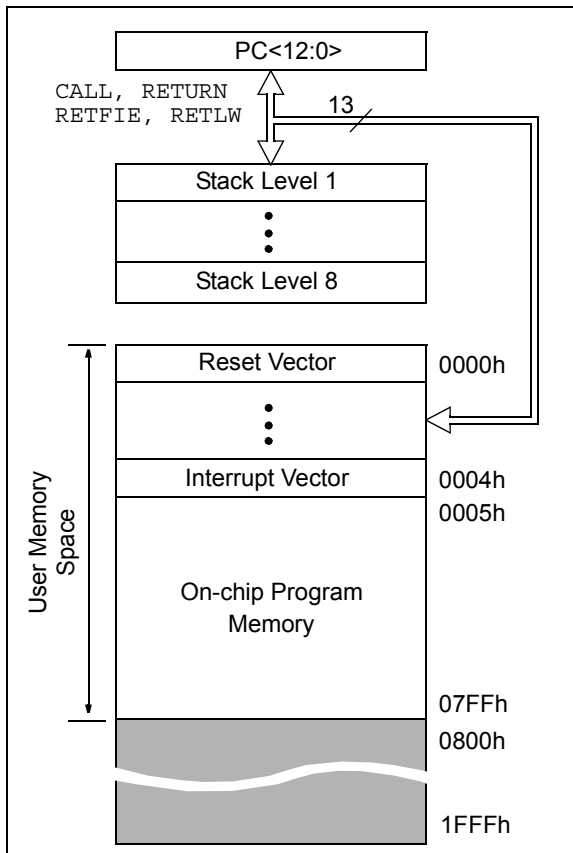
There are two memory blocks in the PIC16F716 device. Each block (program memory and data memory) has its own bus so that concurrent access can occur.

### 2.1 Program Memory Organization

The PIC16F716 has a 13-bit program counter capable of addressing an 8K x 14 program memory space. The PIC16F716 has 2K x 14 words of program memory. Accessing a location above the physically implemented address will cause a wrap-around.

The Reset vector is at 0000h and the interrupt vector is at 0004h.

**FIGURE 2-1: PROGRAM MEMORY MAP AND STACK OF PIC16F716**



### 2.2 Data Memory Organization

The data memory is partitioned into multiple banks which contain the General Purpose Registers (GPR) and the Special Function Registers (SFR). Bits RP1 and RP0 of the STATUS register are the bank select bits.

RP<1:0> <sup>(1)</sup> (Status<6:5>)	Bank
00	0
01	1
10	2 <sup>(2)</sup>
11	3 <sup>(2)</sup>

**Note 1:** Maintain Status bit 6 clear to ensure upward compatibility with future products.

**2:** Not implemented

Each bank extends up to 7Fh (128 bytes). The lower locations of each bank are reserved for the Special Function Registers. Above the Special Function Registers are General Purpose Registers, implemented as static RAM. All implemented banks contain Special Function Registers. The upper 16 bytes of GPR space and some "high use" Special Function Registers in Bank 0 are mirrored in Bank 1 for code reduction and quicker access.

# PIC16F716


## 2.2.1 GENERAL PURPOSE REGISTER FILE

The register file can be accessed either directly or indirectly through the File Select Register FSR (Section 2.5 “Indirect Addressing, INDF and FSR Registers”).

**FIGURE 2-2: REGISTER FILE MAP**

File Address			File Address
00h	INDF <sup>(1)</sup>	INDF <sup>(1)</sup>	80h
01h	TMR0	OPTION_REG	81h
02h	PCL	PCL	82h
03h	STATUS	STATUS	83h
04h	FSR	FSR	84h
05h	PORTA	TRISA	85h
06h	PORTB	TRISB	86h
07h			87h
08h			88h
09h			89h
0Ah	PCLATH	PCLATH	8Ah
0Bh	INTCON	INTCON	8Bh
0Ch	PIR1	PIE1	8Ch
0Dh			8Dh
0Eh	TMR1L	PCON	8Eh
0Fh	TMR1H		8Fh
10h	T1CON		90h
11h	TMR2		91h
12h	T2CON	PR2	92h
13h			93h
14h			94h
15h	CCPR1L		95h
16h	CCPR1H		96h
17h	CCP1CON		97h
18h	PWM1CON		98h
19h	ECCPAS		99h
1Ah			9Ah
1Bh			9Bh
1Ch			9Ch
1Dh			9Dh
1Eh	ADRES		9Eh
1Fh	ADCON0	ADCON1	9Fh
20h	General Purpose Registers 80 Bytes	General Purpose Registers 32 Bytes	A0h
			BFh
6Fh			C0h
			EFh
70h	16 Bytes	Accesses 70-7Fh	F0h
7Fh			FFh

Bank 0                      Bank 1

 Unimplemented data memory locations, read as '0'.

**Note 1:** Not a physical register.

## 2.2.2 SPECIAL FUNCTION REGISTERS

The Special Function Registers are registers used by the CPU and peripheral modules for controlling the desired operation of the device. These registers are implemented as static RAM. A list of these registers is given in Table 2-1.

The Special Function Registers can be classified into two sets; core (CPU) and peripheral. Those registers associated with the core functions are described in detail in this section. Those related to the operation of the peripheral features are described in detail in that peripheral feature section.

**TABLE 2-1: SPECIAL FUNCTION REGISTER SUMMARY BANK 0**

Address	Name	Bit 7	Bit 6	Bit 5	Bit 4	Bit 3	Bit 2	Bit 1	Bit 0	Value on POR, BOR	Page
00h	INDF <sup>(1)</sup>	Addressing this location uses contents of FSR to address data memory (not a physical register)								0000 0000	18
01h	TMR0	Timer0 module's register								xxxx xxxx	27
02h	PCL <sup>(1)</sup>	Program Counter's (PC) Least Significant Byte								0000 0000	17
03h	STATUS <sup>(1)</sup>	IRP <sup>(4)</sup>	RP1 <sup>(4)</sup>	RP0	$\overline{TO}$	$\overline{PD}$	Z	DC	C	0001 1xxx	11
04h	FSR <sup>(1)</sup>	Indirect Data Memory Address Pointer								xxxx xxxx	18
05h	PORTA <sup>(5,6)</sup>	—	—	— <sup>(7)</sup>	RA4	RA3	RA2	RA1	RA0	--x 0000	19
06h	PORTB <sup>(5,6)</sup>	RB7	RB6	RB5	RB4	RB3	RB2	RB1	RB0	xxxx xxxx	21
07h-09h	—	Unimplemented								—	
0Ah	PCLATH <sup>(1,2)</sup>	—	—	—	Write Buffer for the upper 5 bits of the Program Counter				---0 0000	17	
0Bh	INTCON <sup>(1)</sup>	GIE	PEIE	T0IE	INTE	RBIE	TOIF	INTF	RBIF	0000 000x	13
0Ch	PIR1	—	ADIF	—	—	—	CCP1IF	TMR2IF	TMR1IF	-0-- -000	15
0Dh	—	Unimplemented								—	
0Eh	TMR1L	Holding Register for the Least Significant Byte of the 16-bit TMR1 Register								xxxx xxxx	29
0Fh	TMR1H	Holding Register for the Most Significant Byte of the 16-bit TMR1 Register								xxxx xxxx	29
10h	T1CON	—	—	T1CKPS1	T1CKPS0	T1OSCEN	T1SYNC	TMR1CS	TMR1ON	--00 0000	32
11h	TMR2	Timer2 Module's Register								0000 0000	35
12h	T2CON	—	TOUTPS3	TOUTPS2	TOUTPS1	TOUTPS0	TMR2ON	T2CKPS1	T2CKPS0	-000 0000	36
13h-14h	—	Unimplemented								—	
15h	CCPR1L	Capture/Compare/PWM Register 1 (LSB)								xxxx xxxx	48
16h	CCPR1H	Capture/Compare/PWM Register 1 (MSB)								xxxx xxxx	48
17h	CCP1CON	P1M1	P1M0	DC1B1	DC1B0	CCP1M3	CCP1M2	CCP1M1	CCP1M0	0000 0000	48
18h	PWM1CON	PRSEN	PDC6	PDC5	PDC4	PDC3	PDC2	PDC1	PDC0	0000 0000	60
19h	ECCPAS	ECCPASE	ECCPAS2	— <sup>(8)</sup>	ECCPAS0	PSSAC1	PSSAC0	PSSBD1	PSSBD0	00-0 0000	57
1Ah-1Dh	—	Unimplemented								—	
1Eh	ADRES	A/D Result Register								xxxx xxxx	37
1Fh	ADCON0	ADCS1	ADCS0	CHS2	CHS1	CHS0	GO/DONE	— <sup>(7)</sup>	ADON	0000 0000	41

**Legend:** x = unknown, u = unchanged, q = value depends on condition, — = unimplemented, read as '0', Shaded locations are unimplemented, read as '0'.

- Note**
- 1: These registers can be addressed from either bank.
  - 2: The upper byte of the program counter is not directly accessible. PCLATH is a holding register for PC<12:8> whose contents are transferred to the upper byte of the program counter.
  - 3: Other (non Power-up) Resets include: external Reset through  $\overline{MCLR}$  and the Watchdog Timer Reset.
  - 4: The IRP and RP1 bits are reserved. Always maintain these bits clear.
  - 5: On any device Reset, these pins are configured as inputs.
  - 6: This is the value that will be in the PORT output latch.
  - 7: Reserved bits, do not use.
  - 8: ECCPAS1 bit is not used on PIC16F716.

# PIC16F716

**TABLE 2-2: SPECIAL FUNCTION REGISTER SUMMARY BANK 1**

Address	Name	Bit 7	Bit 6	Bit 5	Bit 4	Bit 3	Bit 2	Bit 1	Bit 0	Value on POR, BOR	Page
80h	INDF <sup>(1)</sup>	Addressing this location uses contents of FSR to address data memory (not a physical register)								0000 0000	18
81h	OPTION_REG	$\overline{\text{RBPU}}$	INTEDG	T0CS	T0SE	PSA	PS2	PS1	PS0	1111 1111	12
82h	PCL <sup>(1)</sup>	Program Counter's (PC) Least Significant Byte								0000 0000	17
83h	STATUS <sup>(1)</sup>	IRP <sup>(4)</sup>	RP1 <sup>(4)</sup>	RP0	$\overline{\text{TO}}$	$\overline{\text{PD}}$	Z	DC	C	0001 1xxx	11
84h	FSR <sup>(1)</sup>	Indirect Data Memory Address Pointer								xxxx xxxx	18
85h	TRISA	—	—	— <sup>(7)</sup>	TRISA4	TRISA3	TRISA2	TRISA1	TRISA0	---1 1111	19
86h	TRISB	TRISB7	TRISB6	TRISB5	TRISB4	TRISB3	TRISB2	TRISB1	TRISB0	1111 1111	21
87h-89h	—	Unimplemented								—	
8Ah	PCLATH <sup>(1,2)</sup>	—	—	—	Write Buffer for the upper 5 bits of the Program Counter				---	0000	17
8Bh	INTCON <sup>(1)</sup>	GIE	PEIE	TOIE	INTE	RBIE	TOIF	INTF	RBIF	0000 000x	13
8Ch	PIE1	—	ADIE	—	—	—	CCP1IE	TMR2IE	TMR1IE	-0-- -000	14
8Dh	—	Unimplemented								—	
8Eh	PCON	—	—	—	—	—	—	$\overline{\text{POR}}$	$\overline{\text{BOR}}$	---- -qg	16
8Fh-91h	—	Unimplemented								—	
92h	PR2	Timer2 Period Register								1111 1111	35, 52
93h-9Eh	—	Unimplemented								—	
9Fh	ADCON1	—	—	—	—	—	PCFG2	PCFG1	PCFG0	---- -000	42

**Legend:** x = unknown, u = unchanged, q = value depends on condition, - = unimplemented, read as '0', Shaded locations are unimplemented, read as '0'.

- Note**
- 1: These registers can be addressed from either bank.
  - 2: The upper byte of the program counter is not directly accessible. PCLATH is a holding register for PC<12:8> whose contents are transferred to the upper byte of the program counter.
  - 3: Other (non Power-up) Resets include: external Reset through  $\overline{\text{MCLR}}$  and the Watchdog Timer Reset.
  - 4: The IRP and RP1 bits are reserved. Always maintain these bits clear.
  - 5: On any device Reset, these pins are configured as inputs.
  - 6: This is the value that will be in the PORT output latch.
  - 7: Reserved bits, do not use.

## 2.2.2.1 STATUS Register

The STATUS register, shown in Register 2-1, contains the arithmetic status of the ALU, the Reset status and the bank select bits for data memory.

The STATUS register can be the destination for any instruction, as with any other register. If the STATUS register is the destination for an instruction that affects the Z, DC or C bits, then the write to these three bits is disabled. These bits are set or cleared according to the device logic. Furthermore, the  $\overline{\text{TO}}$  and  $\overline{\text{PD}}$  bits are not writable. Therefore, the result of an instruction with the STATUS register as destination may be different than intended.

For example, `CLRF STATUS` will clear the upper-three bits and set the Z bit. This leaves the STATUS register as `000u u1uu` (where u = unchanged).

It is recommended, therefore, that only `BCF`, `BSF`, `SWAPF` and `MOVWF` instructions are used to alter the STATUS register because these instructions do not affect the Z, C or DC bits from the STATUS register. For other instructions, not affecting any Status bits, see the "Instruction Set Summary."

**Note 1:** The PIC16F716 does not use bits IRP and RP1 of the STATUS register. Maintain these bits clear to ensure upward compatibility with future products.

**2:** The C and DC bits operate as a borrow and digit borrow bit, respectively, in subtraction.

### REGISTER 2-1: STATUS: STATUS REGISTER

Reserved	Reserved	R/W-0	R-1	R-1	R/W-x	R/W-x	R/W-x
IRP	RP1	RP0	$\overline{\text{TO}}$	$\overline{\text{PD}}$	Z	DC	C
bit 7							bit 0

#### Legend:

R = Readable bit                      W = Writable bit                      U = Unimplemented bit, read as '0'  
 -n = Value at POR                      '1' = Bit is set                      '0' = Bit is cleared                      x = Bit is unknown

- bit 7            **IRP:** This bit is reserved and should be maintained as '0'
- bit 6            **RP1:** This bit is reserved and should be maintained as '0'
- bit 5            **RP0:** Register Bank Select bit (used for direct addressing)  
                   1 = Bank 1 (80h-FFh)  
                   0 = Bank 0 (00h-7Fh)
- bit 4             **$\overline{\text{TO}}$ :** Time-out bit  
                   1 = After power-up, `CLRWDT` instruction or `SLEEP` instruction  
                   0 = A WDT time-out occurred
- bit 3             **$\overline{\text{PD}}$ :** Power-down bit  
                   1 = After power-up or by the `CLRWDT` instruction  
                   0 = By execution of the `SLEEP` instruction
- bit 2            **Z:** Zero bit  
                   1 = The result of an arithmetic or logic operation is zero  
                   0 = The result of an arithmetic or logic operation is not zero
- bit 1            **DC:** Digit Carry/Borrow bit (`ADDWF`, `ADDLW`, `SUBLW`, `SUBWF` instructions), For Borrow, the polarity is reversed.  
                   1 = A carry-out from the 4th low-order bit of the result occurred  
                   0 = No carry-out from the 4th low-order bit of the result
- bit 0            **C:** Carry/Borrow bit<sup>(1)</sup> (`ADDWF`, `ADDLW`, `SUBLW`, `SUBWF` instructions)  
                   1 = A carry-out from the Most Significant bit of the result occurred  
                   0 = No carry-out from the Most Significant bit of the result occurred

**Note 1:** For Borrow, the polarity is reversed. A subtraction is executed by adding the two's complement of the second operand. For rotate (`RRF`, `RLF`) instructions, this bit is loaded with either the high-order or low-order bit of the source register.

# PIC16F716

## 2.2.2.2 OPTION Register

The OPTION register is a readable and writable register, which contains various control bits to configure the TMR0 prescaler/WDT postscaler (single assignable register known also as the prescaler), the External INT Interrupt, TMR0 and the weak pull-ups on PORTB.

**Note:** To achieve a 1:1 prescaler assignment for the Timer0 register, assign the prescaler to the Watchdog Timer.

### REGISTER 2-2: OPTION\_REG: OPTION REGISTER

R/W-1	R/W-1	R/W-1	R/W-1	R/W-1	R/W-1	R/W-1	R/W-1
RBPU	INTEDG	T0CS	T0SE	PSA	PS2	PS1	PS0
bit 7							bit 0

**Legend:**

R = Readable bit	W = Writable bit	U = Unimplemented bit, read as '0'
-n = Value at POR	'1' = Bit is set	'0' = Bit is cleared
		x = Bit is unknown

- bit 7      **RBPU:** PORTB Pull-up Enable bit  
 1 = PORTB pull-ups are disabled  
 0 = PORTB pull-ups are enabled by individual PORT latch values
- bit 6      **INTEDG:** Interrupt Edge Select bit  
 1 = Interrupt on rising edge of RB0/INT pin  
 0 = Interrupt on falling edge of RB0/INT pin
- bit 5      **T0CS:** Timer0 Clock Source Select bit  
 1 = Transition on RA4/T0CKI pin  
 0 = Internal instruction cycle clock (Fosc/4)
- bit 4      **T0SE:** Timer0 Source Edge Select bit  
 1 = Increment on high-to-low transition on RA4/T0CKI pin  
 0 = Increment on low-to-high transition on RA4/T0CKI pin
- bit 3      **PSA:** Prescaler Assignment bit  
 1 = Prescaler is assigned to the WDT  
 0 = Prescaler is assigned to the Timer0 module
- bit 2-0    **PS<2:0>:** Prescaler Rate Select bits

Bit Value	Timer0 Rate	WDT Rate
000	1 : 2	1 : 1
001	1 : 4	1 : 2
010	1 : 8	1 : 4
011	1 : 16	1 : 8
100	1 : 32	1 : 16
101	1 : 64	1 : 32
110	1 : 128	1 : 64
111	1 : 256	1 : 128

## 2.2.2.3 INTCON Register

The INTCON Register is a readable and writable register which contains various enable and flag bits for the TMR0 register overflow, RB Port change and external RB0/INT pin interrupts.

**Note:** Interrupt flag bits get set when an interrupt condition occurs, regardless of the state of its corresponding enable bit or the global enable bit, GIE of the INTCON register. User software should ensure the appropriate interrupt flag bits are clear prior to enabling an interrupt.

### REGISTER 2-3: INTCON: INTERRUPT CONTROL REGISTER

R/W-0	R/W-0	R/W-0	R/W-0	R/W-0	R/W-0	R/W-0	R/W-x
GIE	PEIE	TOIE	INTE	RBIE <sup>(1)</sup>	TOIF <sup>(2)</sup>	INTF	RBIF
bit 7							bit 0

**Legend:**

R = Readable bit	W = Writable bit	U = Unimplemented bit, read as '0'
-n = Value at POR	'1' = Bit is set	'0' = Bit is cleared
		x = Bit is unknown

- bit 7      **GIE:** Global Interrupt Enable bit  
1 = Enables all unmasked interrupts  
0 = Disables all interrupts
- bit 6      **PEIE:** Peripheral Interrupt Enable bit  
1 = Enables all unmasked peripheral interrupts  
0 = Disables all peripheral interrupts
- bit 5      **TOIE:** Timer0 Overflow Interrupt Enable bit  
1 = Enables the Timer0 interrupt  
0 = Disables the Timer0 interrupt
- bit 4      **INTE:** RB0/INT External Interrupt Enable bit  
1 = Enables the RB0/INT external interrupt  
0 = Disables the RB0/INT external interrupt
- bit 3      **RBIE:** PORTB Change Interrupt Enable bit<sup>(1)</sup>  
1 = Enables the PORTB change interrupt  
0 = Disables the PORTB change interrupt
- bit 2      **TOIF:** Timer0 Overflow Interrupt Flag bit<sup>(2)</sup>  
1 = TMR0 register has overflowed (must be cleared in software)  
0 = TMR0 register did not overflow
- bit 1      **INTF:** RB0/INT External Interrupt Flag bit  
1 = The RB0/INT external interrupt occurred (must be cleared in software)  
0 = The RB0/INT external interrupt did not occur
- bit 0      **RBIF:** PORTB Change Interrupt Flag bit  
1 = When at least one of the PORTB general purpose I/O pins changed state (must be cleared in software)  
0 = None of the PORTB general purpose I/O pins have changed state

- Note 1:** IOCB register must also be enabled.
- 2:** TOIF bit is set when Timer0 rolls over. Timer0 is unchanged on Reset and should be initialized before clearing TOIF bit.

# PIC16F716

## 2.2.2.4 PIE1 Register

This register contains the individual enable bits for the peripheral interrupts.

**Note:** Bit PEIE of the INTCON register must be set to enable any peripheral interrupt.

### REGISTER 2-4: PIE1: PERIPHERAL INTERRUPT ENABLE REGISTER 1

U-0	R/W-0	U-0	U-0	U-0	R/W-0	R/W-0	R/W-0
—	ADIE	—	—	—	CCP1IE	TMR2IE	TMR1IE
bit 7						bit 0	

**Legend:**

R = Readable bit                      W = Writable bit                      U = Unimplemented bit, read as '0'  
 -n = Value at POR                      '1' = Bit is set                      '0' = Bit is cleared                      x = Bit is unknown

- bit 7                      **Unimplemented:** Read as '0'
- bit 6                      **ADIE:** A/D Converter (ADC) Interrupt Enable bit  
                                  1 = Enables the ADC interrupt  
                                  0 = Disables the ADC interrupt
- bit 5-3                      **Unimplemented:** Read as '0'
- bit 2                      **CCP1IE:** CCP1 Interrupt Enable bit  
                                  1 = Enables the CCP1 interrupt  
                                  0 = Disables the CCP1 interrupt
- bit 1                      **TMR2IE:** Timer2 to PR2 Match Interrupt Enable bit  
                                  1 = Enables the Timer2 to PR2 match interrupt  
                                  0 = Disables the Timer2 to PR2 match interrupt
- bit 0                      **TMR1IE:** Timer1 Overflow Interrupt Enable bit  
                                  1 = Enables the Timer1 overflow interrupt  
                                  0 = Disables the Timer1 overflow interrupt

## 2.2.2.5 PIR1 Register

This register contains the individual flag bits for the peripheral interrupts.

**Note:** Interrupt flag bits get set when an interrupt condition occurs, regardless of the state of its corresponding enable bit or the global enable bit, GIE of the INTCON register. User software should ensure the appropriate interrupt flag bits are clear prior to enabling an interrupt.

### REGISTER 2-5: PIR1: PERIPHERAL INTERRUPT REQUEST REGISTER 1

U-0	R/W-0	R/W-0	R/W-0	R/W-0	U-0	R/W-0	R/W-0
—	ADIF	—	—	—	CCP1IF	TMR2IF	TMR1IF
bit 7							bit 0

**Legend:**

R = Readable bit	W = Writable bit	U = Unimplemented bit, read as '0'
-n = Value at POR	'1' = Bit is set	'0' = Bit is cleared
		x = Bit is unknown

- bit 7      **Unimplemented:** Read as '0'
- bit 6      **ADIF:** A/D Interrupt Flag bit  
             1 = A/D conversion complete  
             0 = A/D conversion has not completed or has not been started
- bit 5-3    **Unimplemented:** Read as '0'
- bit 2      **CCP1IF:** CCP1 Interrupt Flag bit  
             Capture Mode  
             1 = A TMR1 register capture occurred (must be cleared in software)  
             0 = No TMR1 register capture occurred  
             Compare Mode  
             1 = A TMR1 register compare match occurred (must be cleared in software)  
             0 = No TMR1 register compare match occurred  
             PWM Mode  
             Unused in this mode
- bit 1      **TMR2IF:** Timer2 to PR2 Match Interrupt Flag bit  
             1 = Timer2 to PR2 match occurred (must be cleared in software)  
             0 = Timer2 to PR2 match has not occurred
- bit 0      **TMR1IF:** Timer1 Overflow Interrupt Flag bit  
             1 = Timer1 register overflowed (must be cleared in software)  
             0 = Timer1 has not overflowed

# PIC16F716

## 2.2.2.6 PCON Register

The Power Control (PCON) register contains a flag bit to allow differentiation between a Power-on Reset (POR) to an external MCLR Reset or WDT Reset. These devices contain an additional bit to differentiate a Brown-out Reset condition from a Power-on Reset condition.

**Note:** If the BOREN Configuration bit is set, BOR is '1' on Power-on Reset and reset to '0' when a Brown-out condition occurs. BOR must then be set by the user and checked on subsequent Resets to see if it is clear, indicating that another Brown-out has occurred.

If the BOREN Configuration bit is clear, BOR is unknown on Power-on Reset.

### REGISTER 2-6: PCON: POWER CONTROL REGISTER

U-0	U-0	U-0	U-0	U-0	U-0	R/W-0	R/W-x
—	—	—	—	—	—	POR	BOR
bit 7						bit 0	

**Legend:**

R = Readable bit	W = Writable bit	U = Unimplemented bit, read as '0'
-n = Value at POR	'1' = Bit is set	'0' = Bit is cleared      x = Bit is unknown

bit 7-2      **Unimplemented:** Read as '0'

bit 1      **POR:** Power-on Reset Status bit  
 1 = No Power-on Reset occurred  
 0 = A Power-on Reset occurred (must be set in software after a Power-on Reset occurs)

bit 0      **BOR:** Brown-out Reset Status bit  
 1 = No Brown-out Reset occurred  
 0 = A Brown-out Reset occurred (must be set in software after a Brown-out Reset occurs)

## 2.3 PCL and PCLATH

The Program Counter (PC) is 13 bits wide. The low byte comes from the PCL register, which is a readable and writable register. The high byte (PC<12:8>) is not directly readable or writable and comes from PCLATH. On any Reset, the PC is cleared. Figure 2-3 shows the two situations for the loading of the PC. The upper example in Figure 2-3 shows how the PC is loaded on a write to PCL (PCLATH<4:0> → PCH). The lower example in Figure 2-3 shows how the PC is loaded during a CALL or GOTO instruction (PCLATH<4:3> → PCH).

### 2.3.1 MODIFYING PCL

Executing any instruction with the PCL register as the destination simultaneously causes the Program Counter PC<12:8> bits (PCH) to be replaced by the contents of the PCLATH register. This allows the entire contents of the program counter to be changed by writing the desired upper 5 bits to the PCLATH register. When the lower 8 bits are written to the PCL register, all 13 bits of the program counter will change to the values contained in the PCLATH register and those being written to the PCL register.

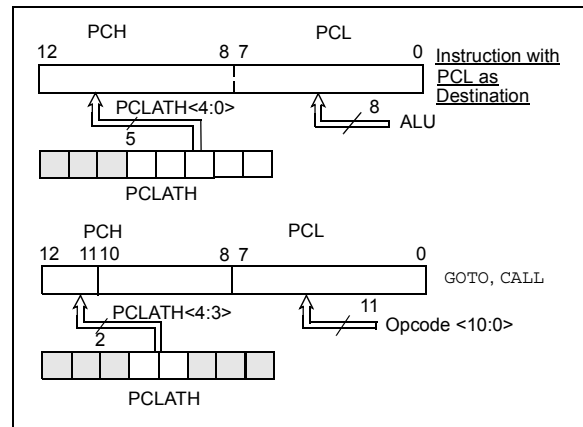
A computed GOTO is accomplished by adding an offset to the program counter (ADDWF PCL). Care should be exercised when jumping into a look-up table or program branch table (computed GOTO) by modifying the PCL register. Assuming that PCLATH is set to the table start address, if the table length is greater than 255 instructions or if the lower 8 bits of the memory address rolls over from 0xFF to 0x00 in the middle of the table, then PCLATH must be incremented for each address rollover that occurs between the table beginning and the target location within the table.

For more information refer to Application Note AN556, "Implementing a Table Read" (DS00556).

### 2.3.2 PROGRAM MEMORY PAGING

The CALL and GOTO instructions provide 11 bits of address to allow branching within any 2K program memory page. When doing a CALL or GOTO instruction, the upper bit of the address is provided by PCLATH<3>. When doing a CALL or GOTO instruction, the user must ensure that the page select bit is programmed so that the desired program memory page is addressed. If a RETURN from a CALL instruction (or interrupt) is executed, the entire 13-bit PC is pushed onto the stack. Therefore, manipulation of the PCLATH<3> bit is not required for the RETURN instructions (which POPs the address from the stack).

**FIGURE 2-3: LOADING OF PC IN DIFFERENT SITUATIONS**



## 2.4 Stack

The stack allows a combination of up to 8 program calls and interrupts to occur. The stack contains the return address from this branch in program execution.

Mid-range devices have an 8-level deep x 13-bit wide hardware stack. The stack space is not part of either program or data space, and the Stack Pointer is not readable or writable. The PC is PUSHed onto the stack when a CALL instruction is executed or an interrupt causes a branch. The stack is POPed in the event of a RETURN, RETLW or a RETFIE instruction execution. PCLATH is not modified when the stack is PUSHed or POPed.

After the stack has been PUSHed 8 times, the ninth push overwrites the value that was stored from the first push. The tenth push overwrites the second push (and so on).

# PIC16F716

## 2.5 Indirect Addressing, INDF and FSR Registers

The INDF register is not a physical register. Addressing INDF actually addresses the register whose address is contained in the FSR register (FSR is a *pointer*). This is indirect addressing.

### EXAMPLE 2-1: INDIRECT ADDRESSING

- Register file 05 contains the value 10h
- Register file 06 contains the value 0Ah
- Load the value 05 into the FSR register
- A read of the INDF register will return the value of 10h
- Increment the value of the FSR register by one (FSR = 06)
- A read of the INDR register now will return the value of 0Ah.

Reading INDF itself indirectly (FSR = 0) will produce 00h. Writing to the INDF register indirectly results in a no-operation (although Status bits may be affected).

A simple program to clear RAM locations 20h-2Fh using indirect addressing is shown in Example 2-2.

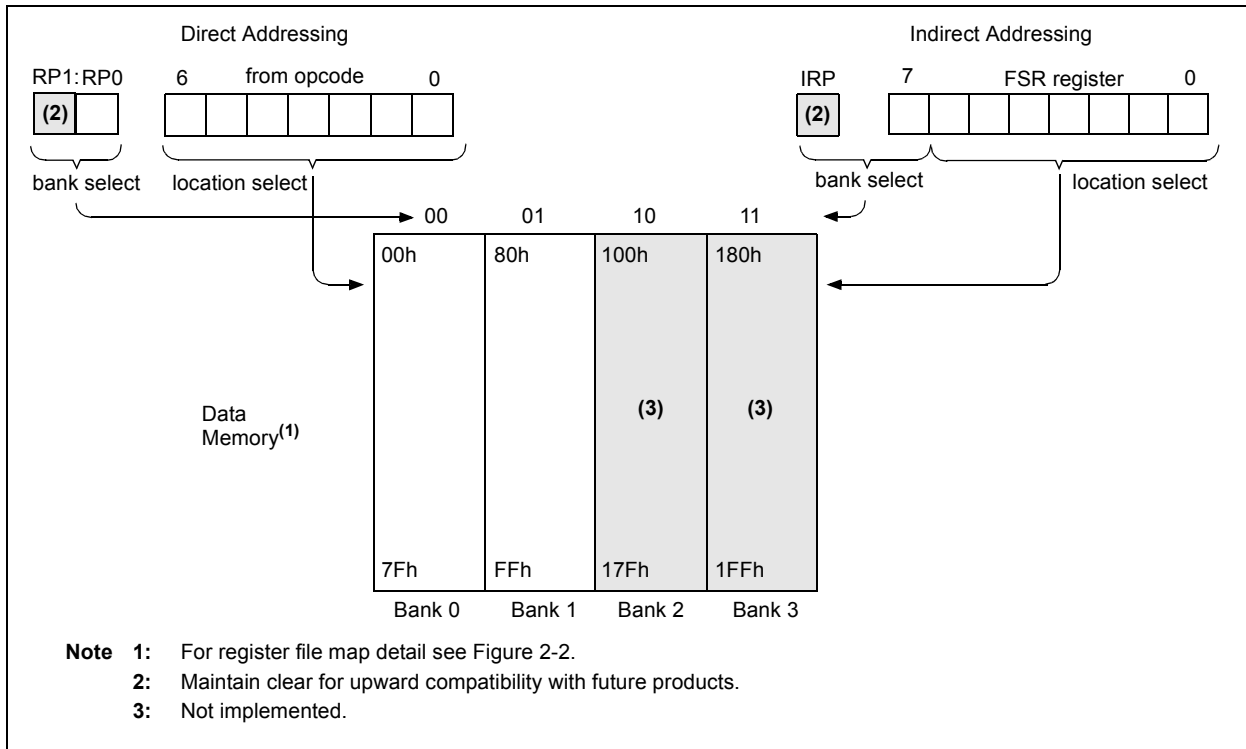
### EXAMPLE 2-2: HOW TO CLEAR RAM USING INDIRECT ADDRESSING

```

MOV LW 0x20 ;initialize pointer
MOV WF FSR ;to RAM
NEXT   CLR F INDF ;clear RAM & FSR
      INC F FSR ;inc pointer
      BTFSS FSR,4 ;all done?
      GOTO NEXT ;no, clear next
CONTINUE
      : ;yes, continue
    
```

An effective 9-bit address is obtained by concatenating the 8-bit FSR register and the IRP bit of the STATUS register, as shown in Figure 2-4. However, IRP is not used in the PIC16F716.

FIGURE 2-4: DIRECT/INDIRECT ADDRESSING



## 3.0 I/O PORTS

Some pins for these I/O ports are multiplexed with an alternate function for the peripheral features on the device. In general, when a peripheral is enabled, that pin may not be used as a general purpose I/O pin.

### 3.1 PORTA and the TRISA Register

PORTA is a 5-bit wide bidirectional port. The corresponding data direction register is TRISA. Setting a TRISA bit (= 1) will make the corresponding PORTA pin an input (i.e., put the corresponding output driver in a High-impedance mode). Clearing a TRISA bit (= 0) will make the corresponding PORTA pin an output (i.e., put the contents of the output latch on the selected pin).

Reading the PORTA register reads the status of the pins, whereas writing to it will write to the PORT latch. All write operations are read-modify-write operations. Therefore, a write to a port implies that the port pins are read, the value is modified and then written to the PORT data latch.

Pin RA4 is multiplexed with the Timer0 module clock input to become the RA4/T0CKI pin. The RA4/T0CKI pin is a Schmitt Trigger input and an open drain output. All other RA port pins have TTL input levels and full CMOS output drivers.

PORTA pins, RA<3:0>, are multiplexed with analog inputs and analog VREF input. The operation of each pin is selected by clearing/setting the control bits in the ADCON1 register (A/D Control Register 1).

**Note:** On a Power-on Reset, these pins are configured as analog inputs and read as '0'.

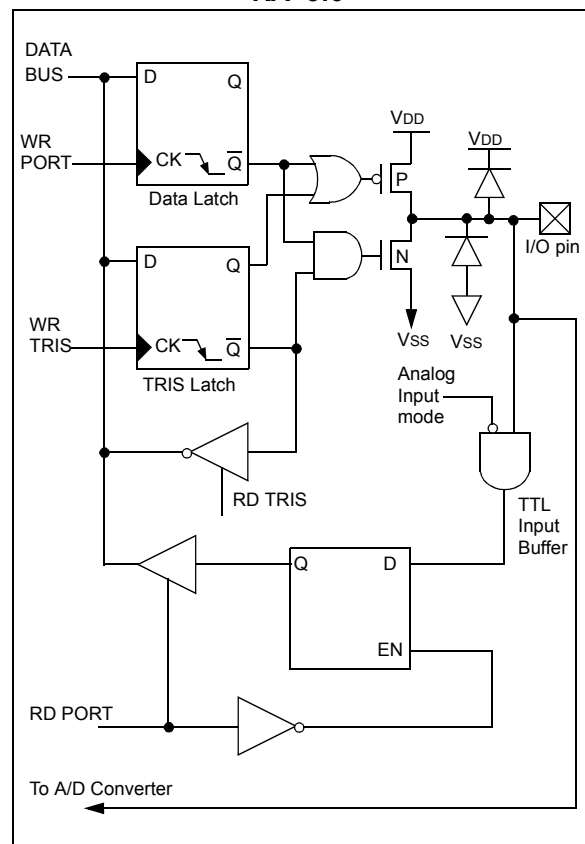
The TRISA register controls the direction of the RA pins, even when they are being used as analog inputs. The user must ensure the bits in the TRISA register are maintained set when using them as analog inputs.

**Note:** Setting RA3:0 to output while in Analog mode will force pins to output contents of data latch.

### EXAMPLE 3-1: INITIALIZING PORTA

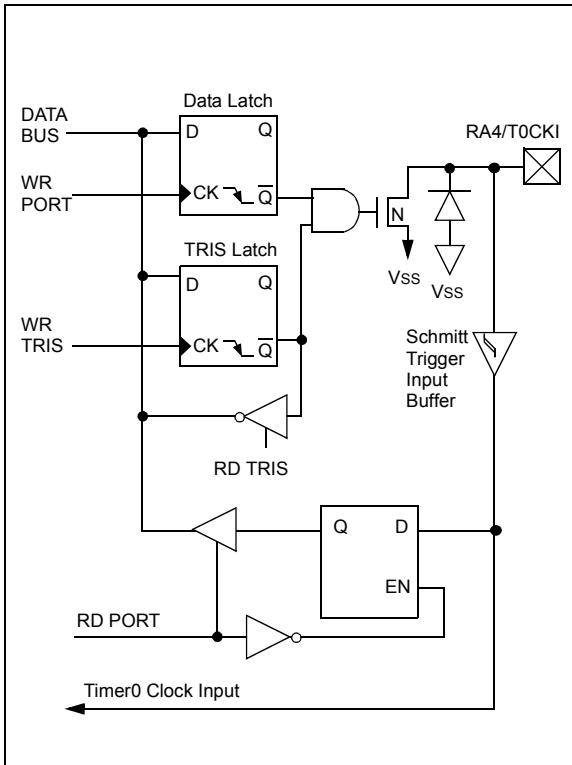
```
BCF STATUS, RP0 ;
CLRF PORTA ;Initialize PORTA by
;clearing output
;data latches
BSF STATUS, RP0 ;Select Bank 1
MOVLW 0xEF ;Value used to
;initialize data
;direction
MOVWF TRISA ;Set RA<3:0> as inputs
;RA<4> as outputs
BCF STATUS, RP0 ;Return to Bank 0
```

**FIGURE 3-1: BLOCK DIAGRAM OF RA<3:0>**



# PIC16F716

**FIGURE 3-2: BLOCK DIAGRAM OF RA4/T0CKI PIN**



**TABLE 3-1: SUMMARY OF REGISTERS ASSOCIATED WITH PORTA**

Name	Bit 7	Bit 6	Bit 5	Bit 4	Bit 3	Bit 2	Bit 1	Bit 0	Value on POR, BOR	Value on all other Resets
PORTA	—	—	—	RA4	RA3	RA2	RA1	RA0	---x 0000	---u uuuu
TRISA	—	—	—	TRISA4	TRISA3	TRISA2	TRISA1	TRISA0	---1 1111	---1 1111
ADCON1	—	—	—	—	—	PCFG2	PCFG1	PCFG0	---- -000	---- -000

**Legend:** x = unknown, u = unchanged, - = unimplemented locations read as '0'. Shaded cells are not used by PORTA.

## 3.2 PORTB and the TRISB Register

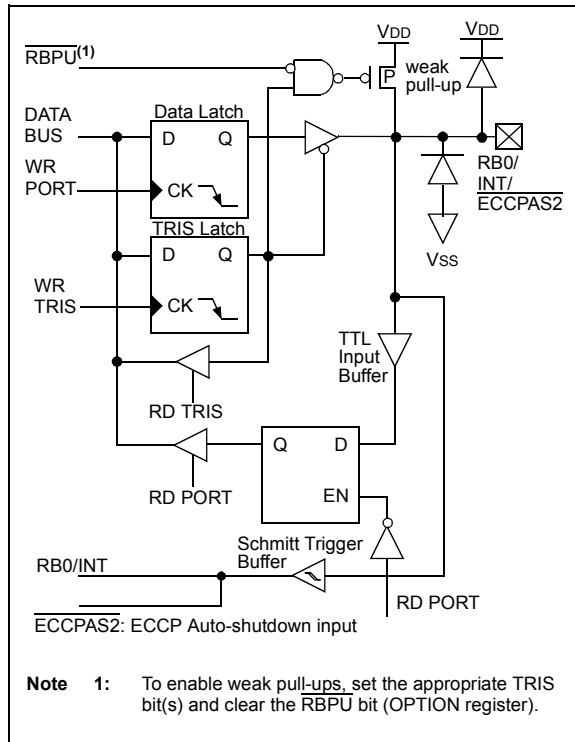
PORTB is an 8-bit wide bidirectional port. The corresponding data direction register is TRISB. Setting a TRISB bit (= 1) will make the corresponding PORTB pin an input (i.e., put the corresponding output driver in a High-Impedance mode). Clearing a TRISB bit (= 0) will make the corresponding PORTB pin an output (i.e., put the contents of the output latch on the selected pin).

### EXAMPLE 3-2: INITIALIZING PORTB

```
BCF    STATUS, RP0    ;select Bank 0
CLRF   PORTB         ;Initialize PORTB by
                    ;clearing output
                    ;data latches
BSF    STATUS, RP0    ;Select Bank 1
MOVLW  0xCF          ;Value used to
                    ;initialize data
                    ;direction
MOVWF  TRISB         ;Set RB<3:0> as inputs
                    ;RB<5:4> as outputs
                    ;RB<7:6> as inputs
```

Each of the PORTB pins has a weak internal pull-up. A single control bit can turn on all the pull-ups. This is performed by clearing bit  $\overline{RBPU}$  of the OPTION register. The weak pull-up is automatically turned off when the port pin is configured as an output. The pull-ups are disabled on a Power-on Reset.

**FIGURE 3-3: BLOCK DIAGRAM OF RB0/INT/ECCPAS2 PIN**



When enabling peripheral functions, care should be taken in defining TRIS bits for each PORTB pin. Some peripherals override the TRIS bit to make a pin an output, while other peripherals override the TRIS bit to make a pin an input. Since the TRIS bit override is in effect while the peripheral is enabled, read-modify-write instructions (such as BSF, BCF, XORWF) with TRISB as the destination should be avoided. The user should refer to the corresponding peripheral section for the correct TRIS bit settings.

Four of PORTB's pins, RB<7:4>, have an interrupt-on-change feature. Only pins configured as inputs can cause this interrupt to occur (i.e., any RB<7:4> pin configured as an output is excluded from the interrupt-on-change comparison). The input pins, RB<7:4>, are compared with the old value latched on the last read of PORTB. The "mismatch" outputs of RB<7:4> are OR'ed together to generate the RB Port Change Interrupt with flag bit RBIF of the INTCON register.

This interrupt can wake the device from Sleep. The user, in the Interrupt Service Routine, can clear the interrupt in the following manner:

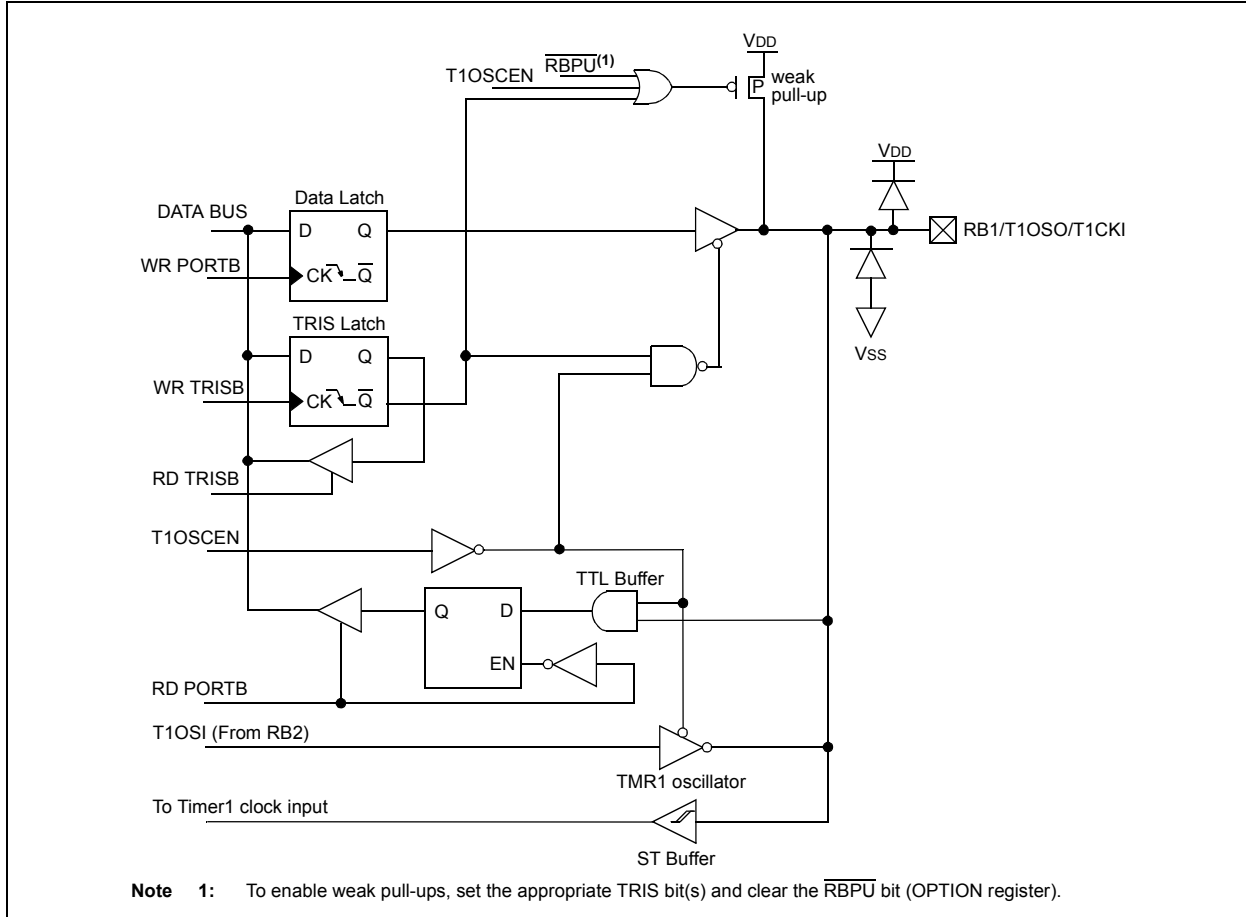
1. Perform a read of PORTB to end the mismatch condition.
2. Clear flag bit RBIF.

A mismatch condition will continue to set flag bit RBIF. Reading PORTB will end the mismatch condition and allow flag bit RBIF to be cleared.

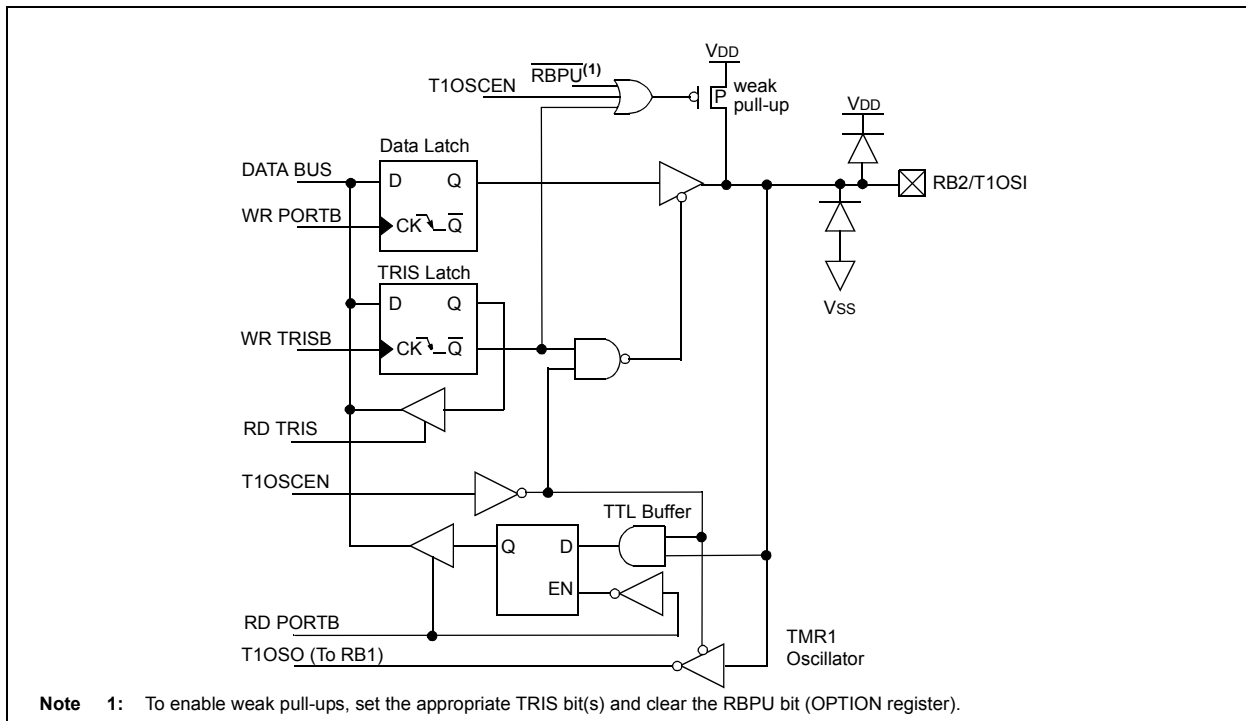
The interrupt-on-change feature is recommended for wake-up on key depression operation and operations where PORTB is only used for the interrupt-on-change feature. Polling of PORTB is not recommended while using the interrupt-on-change feature.

# PIC16F716

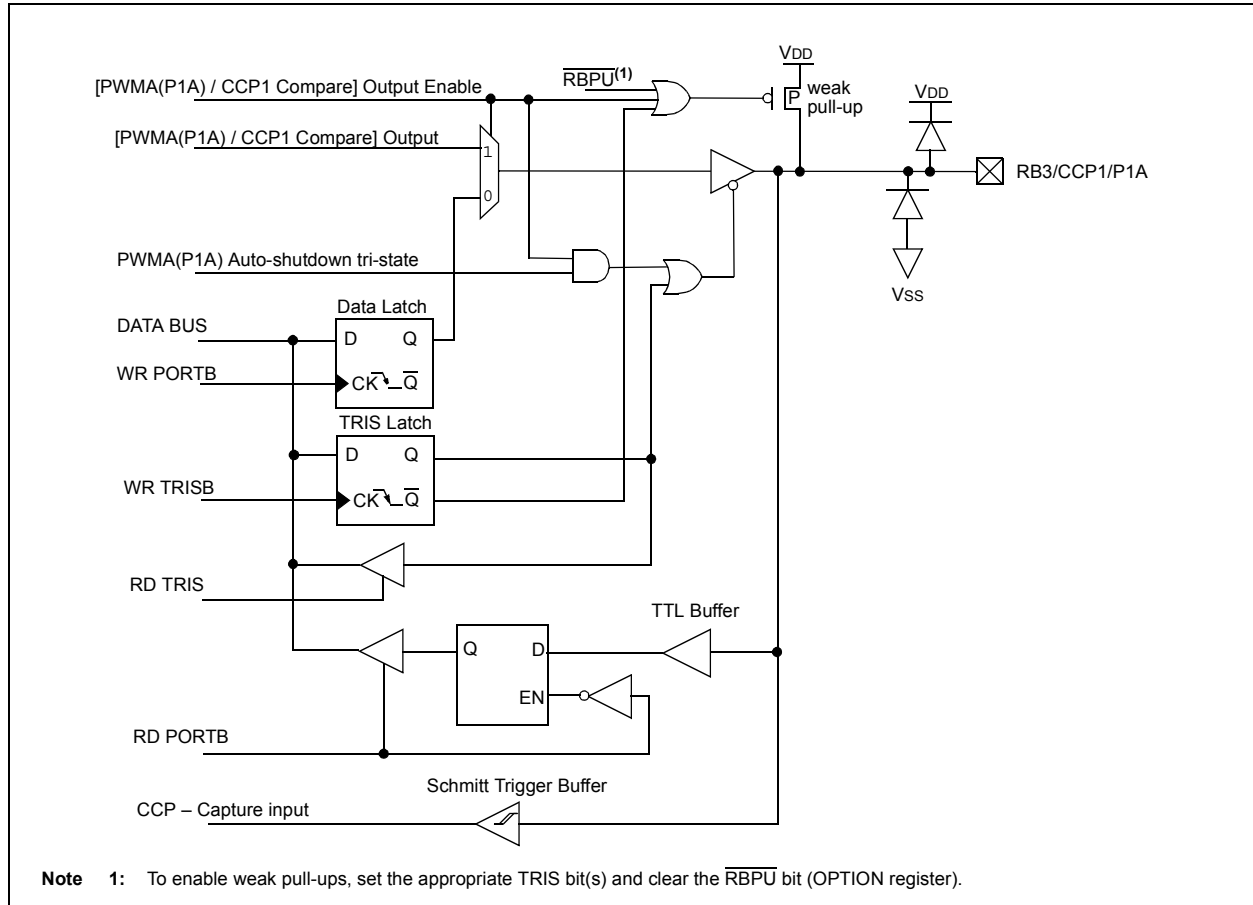
**FIGURE 3-4: BLOCK DIAGRAM OF RB1/T1OSO/T1CKI PIN**



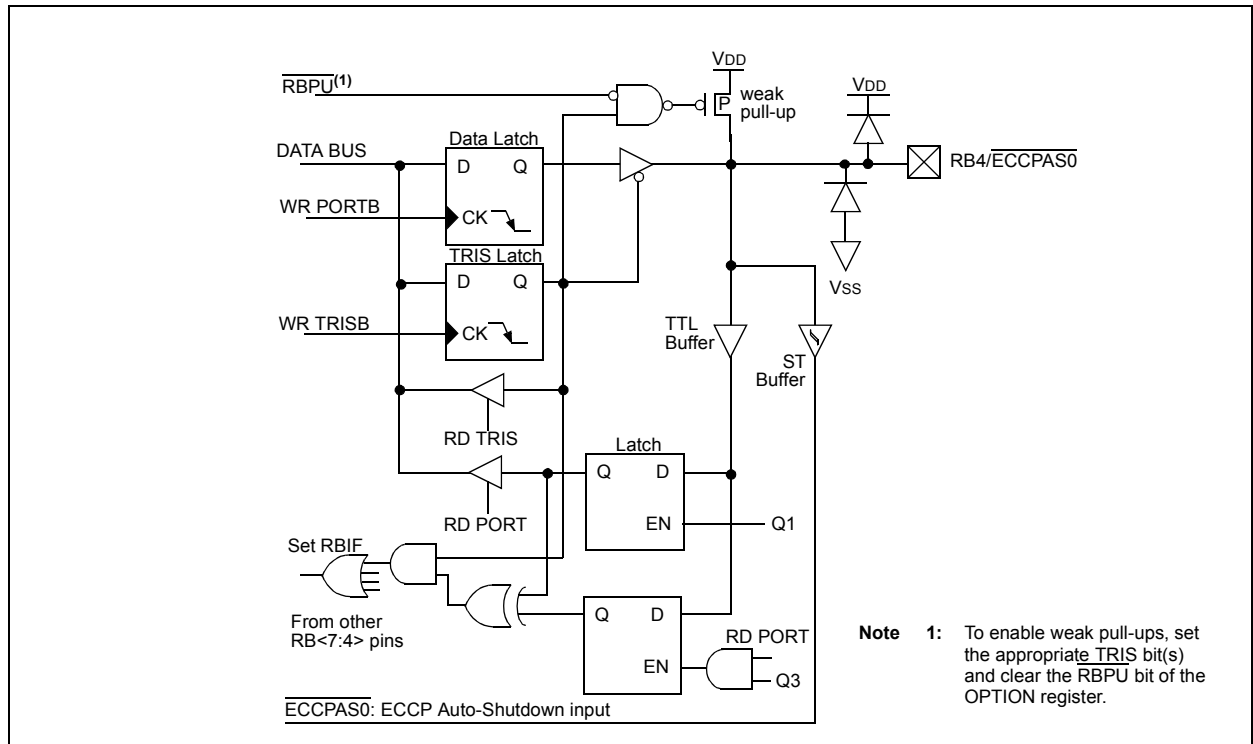
**FIGURE 3-5: BLOCK DIAGRAM OF RB2/T1OSI PIN**



**FIGURE 3-6: BLOCK DIAGRAM OF RB3/CCP1/P1A PIN**

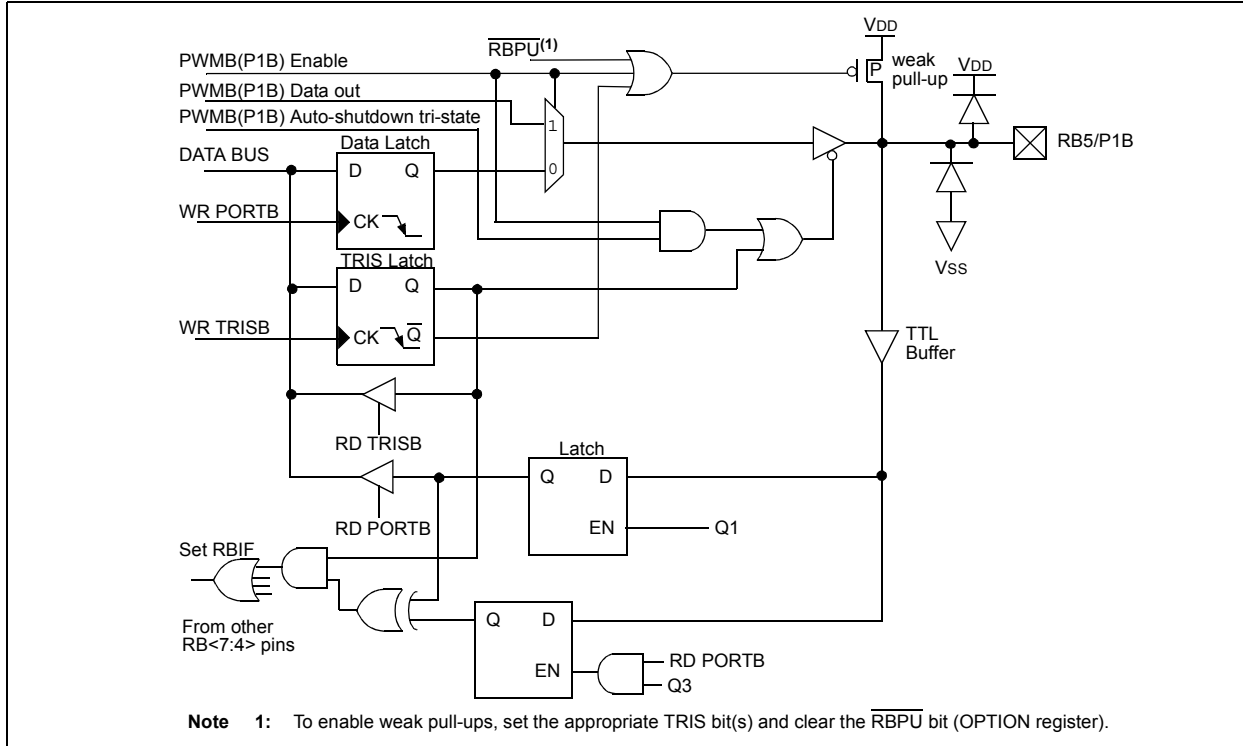


**FIGURE 3-7: BLOCK DIAGRAM OF RB4/ECCPAS0 PIN**

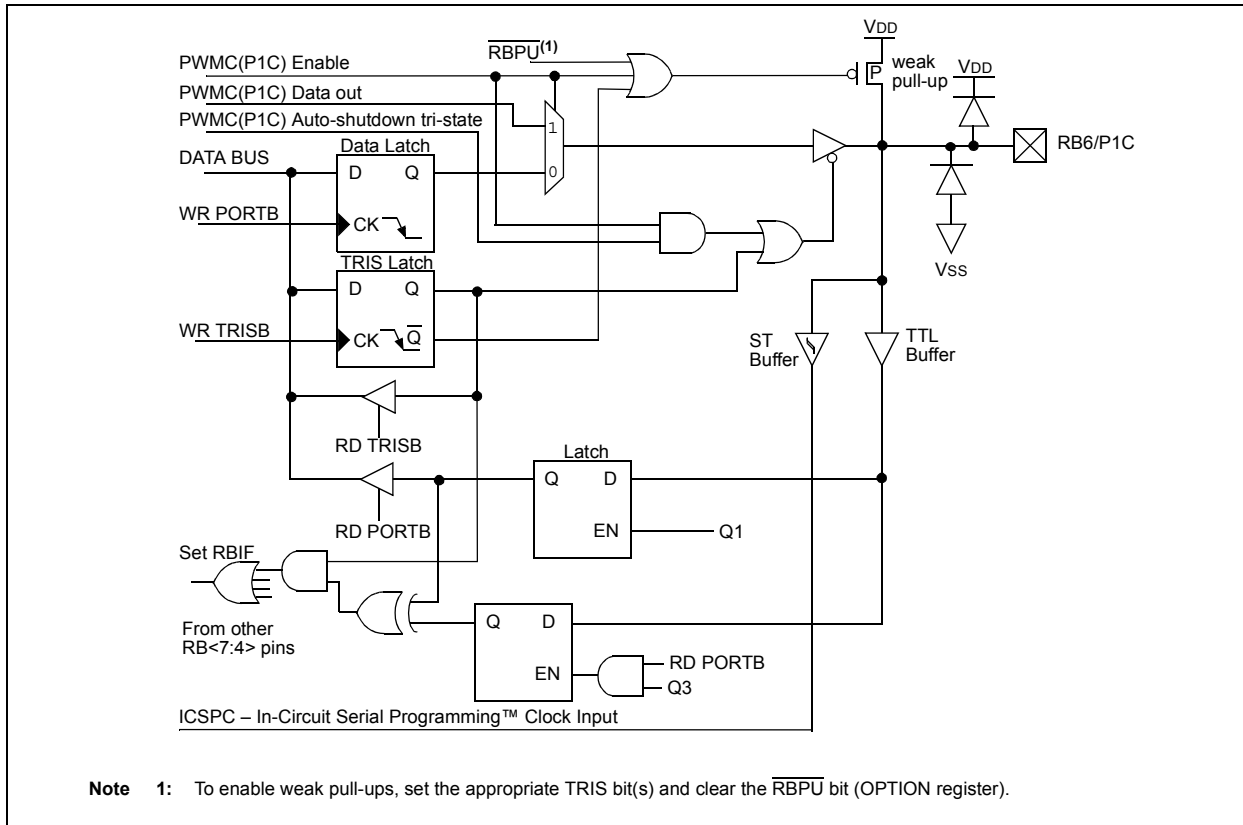


# PIC16F716

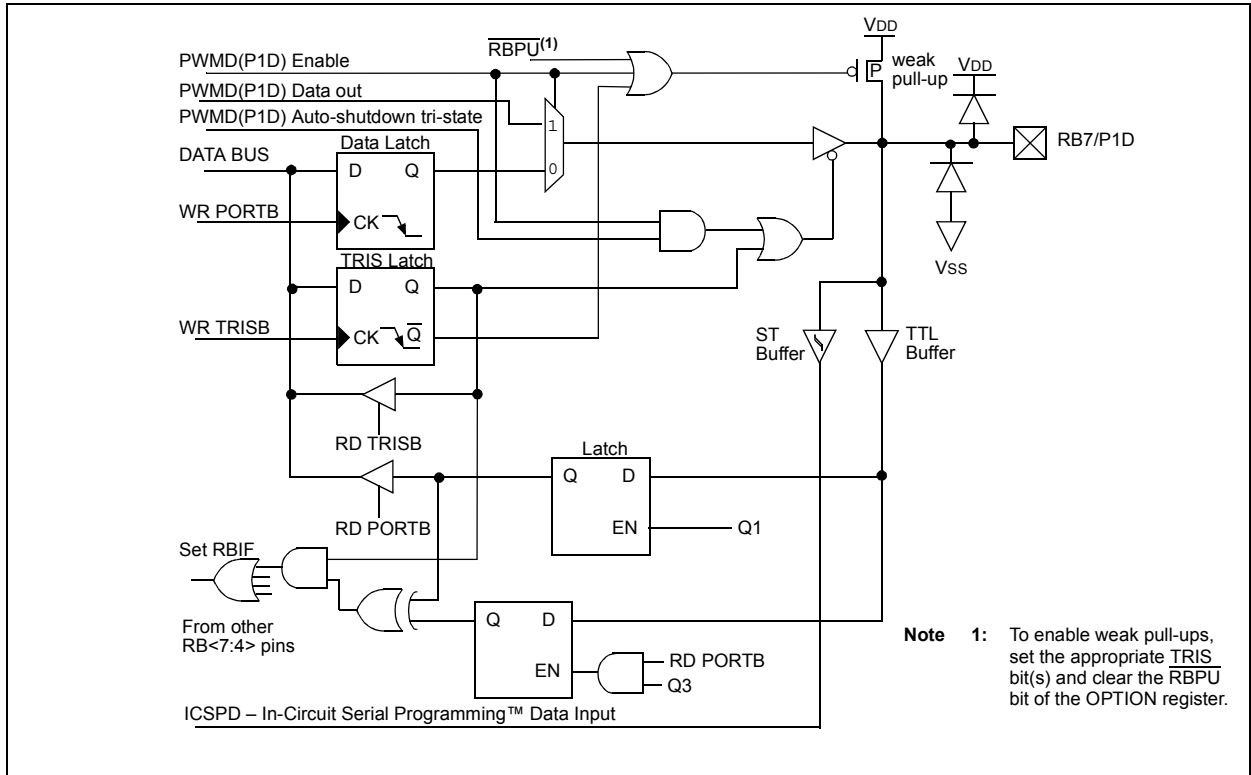
**FIGURE 3-8: BLOCK DIAGRAM OF RB5/P1B PIN**



**FIGURE 3-9: BLOCK DIAGRAM OF RB6/P1C PIN**



**FIGURE 3-10: BLOCK DIAGRAM OF RB7/P1D PIN**



**TABLE 3-2: SUMMARY OF REGISTERS ASSOCIATED WITH PORTB**

Name	Bit 7	Bit 6	Bit 5	Bit 4	Bit 3	Bit 2	Bit 1	Bit 0	Value on POR, BOR	Value on all other Resets
PORTB	RB7	RB6	RB5	RB4	RB3	RB2	RB1	RB0	xxxx xxxx	uuuu uuuu
TRISB	TRISB7	TRISB6	TRISB5	TRISB4	TRISB3	TRISB2	TRISB1	TRISB0	1111 1111	1111 1111
OPTION_REG	$\overline{\text{RBP1}}$	INTEDG	T0CS	T0SE	PSA	PS2	PS1	PS0	1111 1111	1111 1111

**Legend:** x = unknown, u = unchanged. Shaded cells are not used by PORTB.

# PIC16F716

---

NOTES:

## 4.0 TIMER0 MODULE

The Timer0 module is an 8-bit timer/counter with the following features:

- 8-bit timer/counter register (TMR0)
- 8-bit prescaler (shared with Watchdog Timer)
- Programmable internal or external clock source
- Programmable external clock edge selection
- Interrupt on overflow

Figure 4-1 is a block diagram of the Timer0 module.

## 4.1 Timer0 Operation

When used as a timer, the Timer0 module can be used as either an 8-bit timer or an 8-bit counter.

### 4.1.1 8-BIT TIMER MODE

When used as a timer, the Timer0 module will increment every instruction cycle (without prescaler). Timer mode is selected by clearing the T0CS bit of the OPTION register to '0'.

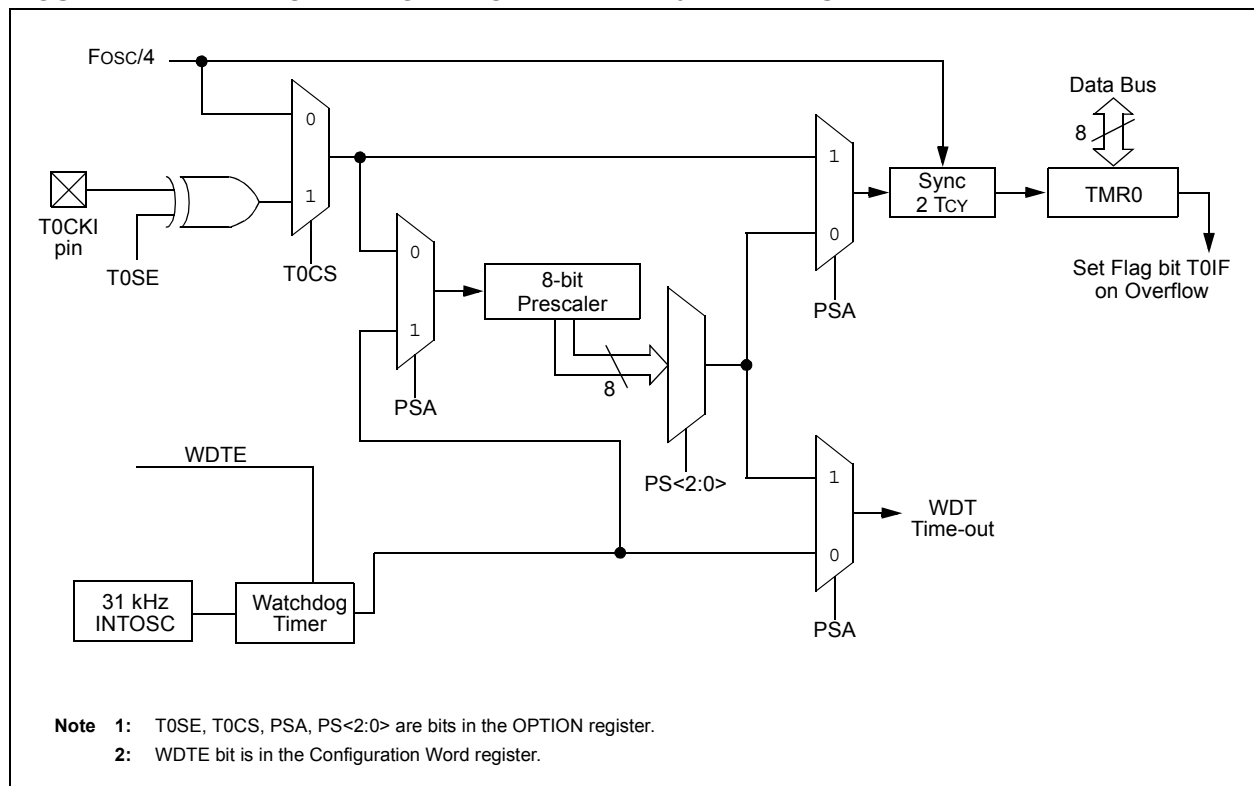
When TMR0 is written, the increment is inhibited for two instruction cycles immediately following the write.

**Note:** The value written to the TMR0 register can be adjusted, in order to account for the two instruction cycle delay when TMR0 is written.

### 4.1.2 8-BIT COUNTER MODE

When used as a counter, the Timer0 module will increment on every rising or falling edge of the T0CKI pin. The incrementing edge is determined by the T0SE bit of the OPTION register. Counter mode is selected by setting the T0CS bit of the OPTION register to '1'.

**FIGURE 4-1: BLOCK DIAGRAM OF THE TIMER0/WDT PRESCALER**



# PIC16F716

## 4.1.3 SOFTWARE PROGRAMMABLE PRESCALER

A single software programmable prescaler is available for use with either Timer0 or the Watchdog Timer (WDT), but not both simultaneously. The prescaler assignment is controlled by the PSA bit of the OPTION register. To assign the prescaler to Timer0, the PSA bit must be cleared to a '0'.

There are 8 prescaler options for the Timer0 module ranging from 1:2 to 1:256. The prescale values are selectable via the PS<2:0> bits of the OPTION register. In order to have a 1:1 prescaler value for the Timer0 module, the prescaler must be assigned to the WDT module.

The prescaler is not readable or writable. When assigned to the Timer0 module, all instructions writing to the TMR0 register will clear the prescaler.

When the prescaler is assigned to WDT, a CLRWDT instruction will clear the prescaler along with the WDT.

### 4.1.3.1 Switching Prescaler Between Timer0 and WDT Modules

As a result of having the prescaler assigned to either Timer0 or the WDT, it is possible to generate an unintended device Reset when switching prescaler values. When changing the prescaler assignment from Timer0 to the WDT module, the instruction sequence shown in Example 4-1, must be executed.

#### EXAMPLE 4-1: CHANGING PRESCALER (TIMER0 → WDT)

```

BANKSEL  TMR0          ;
CLRWDT   TMR0          ;Clear WDT
CLRF     TMR0          ;Clear TMR0 and
                        ;prescaler

BANKSEL  OPTION_REG    ;
BSF      OPTION_REG,PSA ;Select WDT
CLRWDT   ;
                        ;

MOVLW    b'11111000'   ;Mask prescaler
ANDWF    OPTION_REG,W  ;bits
IORLW    b'00000101'   ;Set WDT prescaler
MOVWF    OPTION_REG    ;to 1:32
    
```

When changing the prescaler assignment from the WDT to the Timer0 module, the following instruction sequence must be executed (see Example 4-2).

#### EXAMPLE 4-2: CHANGING PRESCALER (WDT → TIMER0)

```

CLRWDT   ;Clear WDT and
                        ;prescaler

BANKSEL  OPTION_REG    ;
MOVLW    b'11110000'   ;Mask TMR0 select and
ANDWF    OPTION_REG,W  ;prescaler bits
IORLW    b'00000011'   ;Set prescale to 1:16
MOVWF    OPTION_REG    ;
    
```

## 4.1.4 TIMER0 INTERRUPT

Timer0 will generate an interrupt when the TMR0 register overflows from FFh to 00h. The TOIF interrupt flag bit of the INTCON register is set every time the TMR0 register overflows, regardless of whether or not the Timer0 interrupt is enabled. The TOIF bit must be cleared in software. The Timer0 interrupt enable is the TOIE bit of the INTCON register.

**Note:** The Timer0 interrupt cannot wake the processor from Sleep since the timer is frozen during Sleep.

## 4.1.5 USING TIMER0 WITH AN EXTERNAL CLOCK

When Timer0 is in Counter mode, the synchronization of the T0CKI input and the Timer0 register is accomplished by sampling the prescaler output on the Q2 and Q4 cycles of the internal phase clocks. Therefore, the high and low periods of the external clock source must meet the timing requirements as shown in the Section 12.0 "Electrical Characteristics".

TABLE 4-1: SUMMARY OF REGISTERS ASSOCIATED WITH TIMER0

Name	Bit 7	Bit 6	Bit 5	Bit 4	Bit 3	Bit 2	Bit 1	Bit 0	Value on POR, BOR	Value on all other Resets
TMR0	Timer0 Module Register								xxxx xxxx	uuuu uuuu
INTCON	GIE	PEIE	TOIE	INTE	RBIE	TOIF	INTF	RBIF	0000 000x	0000 000u
OPTION_REG	$\overline{\text{RBPU}}$	INTEDG	T0CS	T0SE	PSA	PS2	PS1	PS0	1111 1111	1111 1111
TRISA	—	—	—	TRISA4	TRISA3	TRISA2	TRISA1	TRISA0	---1 1111	---1 1111

**Legend:** — = Unimplemented locations, read as '0', u = unchanged, x = unknown. Shaded cells are not used by the Timer0 module.

## 5.0 TIMER1 MODULE WITH GATE CONTROL

The Timer1 module is a 16-bit timer/counter with the following features:

- 16-bit timer/counter register pair (TMR1H:TMR1L)
- Programmable internal or external clock source
- 3-bit prescaler
- Optional LP oscillator
- Synchronous or asynchronous operation
- Interrupt on overflow
- Wake-up on overflow (external clock, Asynchronous mode only)
- Time base for the Capture/Compare function
- Special Event Trigger (with ECCP)

Figure 5-1 is a block diagram of the Timer1 module.

## 5.1 Timer1 Operation

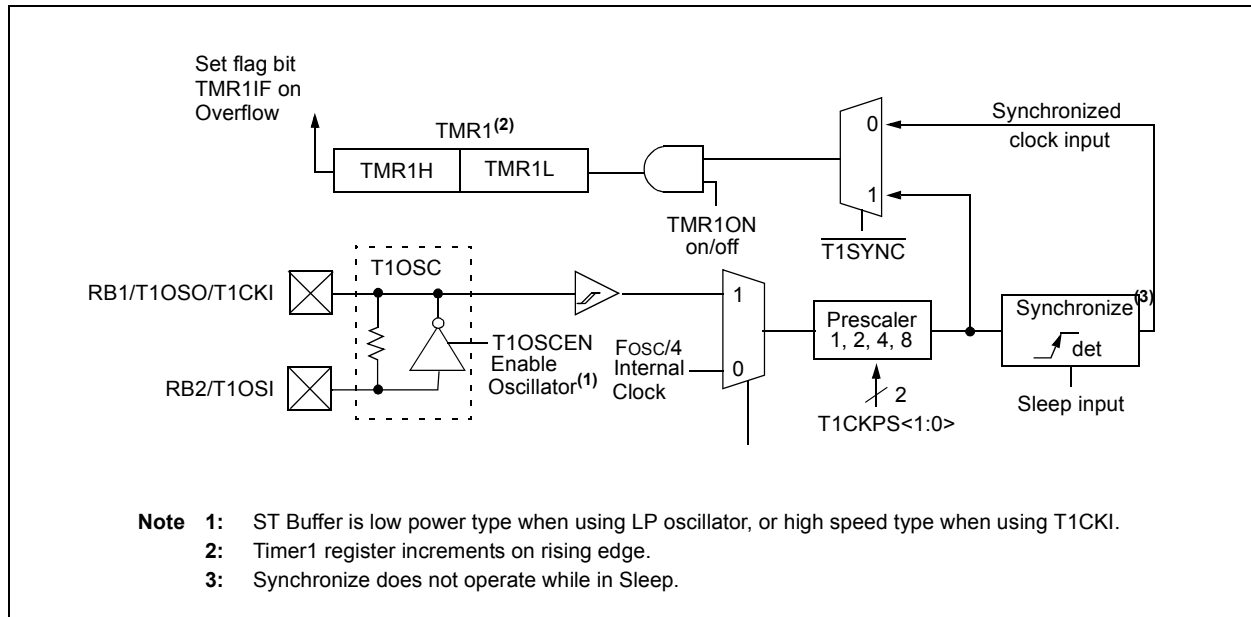
The Timer1 module is a 16-bit incrementing counter which is accessed through the TMR1H:TMR1L register pair. Writes to TMR1H or TMR1L directly update the counter.

When used with an internal clock source, the module is a timer. When used with an external clock source, the module can be used as either a timer or counter.

## 5.2 Clock Source Selection

The TMR1CS bit of the T1CON register is used to select the clock source. When TMR1CS = 0, the clock source is  $F_{osc}/4$ . When TMR1CS = 1, the clock source is supplied externally.

**FIGURE 5-1: TIMER1 BLOCK DIAGRAM**



### 5.2.1 INTERNAL CLOCK SOURCE

When the internal clock source is selected, the TMR1H:TMR1L register pair will increment on multiples of  $T_{cy}$  as determined by the Timer1 prescaler.

### 5.2.2 EXTERNAL CLOCK SOURCE

When the external clock source is selected, the Timer1 module may work as a timer or a counter.

When counting, Timer1 is incremented on the rising edge of the external clock input T1CKI. In addition, the Counter mode clock can be synchronized to the microcontroller system clock or run asynchronously.

In Counter mode, a falling edge must be registered by the counter prior to the first incrementing rising edge after one or more of the following conditions:

- Timer1 is enabled after POR or BOR Reset
- A write to TMR1H or TMR1L
- T1CKI is high when Timer1 is disabled and when Timer1 is reenabled T1CKI is low. See Figure 5-2.

# PIC16F716

## 5.3 Timer1 Prescaler

Timer1 has four prescaler options allowing 1, 2, 4 or 8 divisions of the clock input. The T1CKPS bits of the T1CON register control the prescale counter. The prescale counter is not directly readable or writable; however, the prescaler counter is cleared upon a write to TMR1H or TMR1L.

## 5.4 Timer1 Oscillator

A low-power 32.768 kHz crystal oscillator is built-in between pins T1OSI (input) and T1OSO (output). The oscillator is enabled by setting the T1OSCN control bit of the T1CON register. The oscillator will continue to run during Sleep.

The Timer1 oscillator is shared with the system LP oscillator. Thus, Timer1 can use this mode only when the primary system clock is derived from the internal oscillator or when in LP oscillator mode. The user must provide a software time delay to ensure proper oscillator start-up.

TRISB1 and TRISB2 bits are set when the Timer1 oscillator is enabled. RB1 and RB2 bits read as '0' and TRISB1 and TRISB2 bits read as '1'.

**Note:** The oscillator requires a start-up and stabilization time before use. Thus, T1OSCN should be set and a suitable delay observed prior to enabling Timer1.

## 5.5 Timer1 Operation in Asynchronous Counter Mode

If control bit T1SYNC of the T1CON register is set, the external clock input is not synchronized. The timer continues to increment asynchronous to the internal phase clocks. The timer will continue to run during Sleep and can generate an interrupt on overflow, which will wake-up the processor. However, special precautions in software are needed to read/write the timer (see **Section 5.5.1 "Reading and Writing Timer1 in Asynchronous Counter Mode"**).

**Note 1:** When switching from synchronous to asynchronous operation, it is possible to skip an increment. When switching from asynchronous to synchronous operation, it is possible to produce an additional increment.

**2:** In Asynchronous Counter mode, Timer1 can not be used as a time base for the Capture or Compare modes of the ECCP module.

## 5.5.1 READING AND WRITING TIMER1 IN ASYNCHRONOUS COUNTER MODE

Reading TMR1H or TMR1L while the timer is running from an external asynchronous clock will ensure a valid read (taken care of in hardware). However, the user should keep in mind that reading the 16-bit timer in two 8-bit values itself poses certain problems, since the timer may overflow between the reads.

For writes, it is recommended that the user simply stop the timer and write the desired values. A write contention may occur by writing to the timer registers, while the register is incrementing. This may produce an unpredictable value in the TMR1H:TMR1L register pair.

## 5.6 Timer1 Interrupt

The Timer1 register pair (TMR1H:TMR1L) increments to FFFFh and rolls over to 0000h. When Timer1 rolls over, the Timer1 interrupt flag bit of the PIR1 register is set. To enable the interrupt on rollover, you must set these bits:

- Timer1 interrupt enable bit of the PIE1 register
- PEIE bit of the INTCON register
- GIE bit of the INTCON register

The interrupt is cleared by clearing the TMR1IF bit in the Interrupt Service Routine.

**Note:** The TMR1H:TMR1L register pair and the TMR1IF bit should be cleared before enabling interrupts.

## 5.7 Timer1 Operation During Sleep

Timer1 can only operate during Sleep when setup in Asynchronous Counter mode. In this mode, an external crystal or clock source can be used to increment the counter. To set up the timer to wake the device:

- TMR1ON bit of the T1CON register must be set
- TMR1IE bit of the PIE1 register must be set
- PEIE bit of the INTCON register must be set

The device will wake-up on an overflow and execute the next instruction. If the GIE bit of the INTCON register is set, the device will call the Interrupt Service Routine (0004h).

## 5.8 ECCP Capture/Compare Time Base

The ECCP module uses the TMR1H:TMR1L register pair as the time base when operating in Capture or Compare mode.

In Capture mode, the value in the TMR1H:TMR1L register pair is copied into the CCPR1H:CCPR1L register pair on a configured event.

In Compare mode, an event is triggered when the value CCPR1H:CCPR1L register pair matches the value in the TMR1H:TMR1L register pair. This event can be a Special Event Trigger.

For more information, see **Section 8.0 “Enhanced Capture/Compare/PWM Module”**.

## 5.9 ECCP Special Event Trigger

If a ECCP is configured to trigger a special event, the trigger will clear the TMR1H:TMR1L register pair. This special event does not cause a Timer1 interrupt. The ECCP module may still be configured to generate a ECCP interrupt.

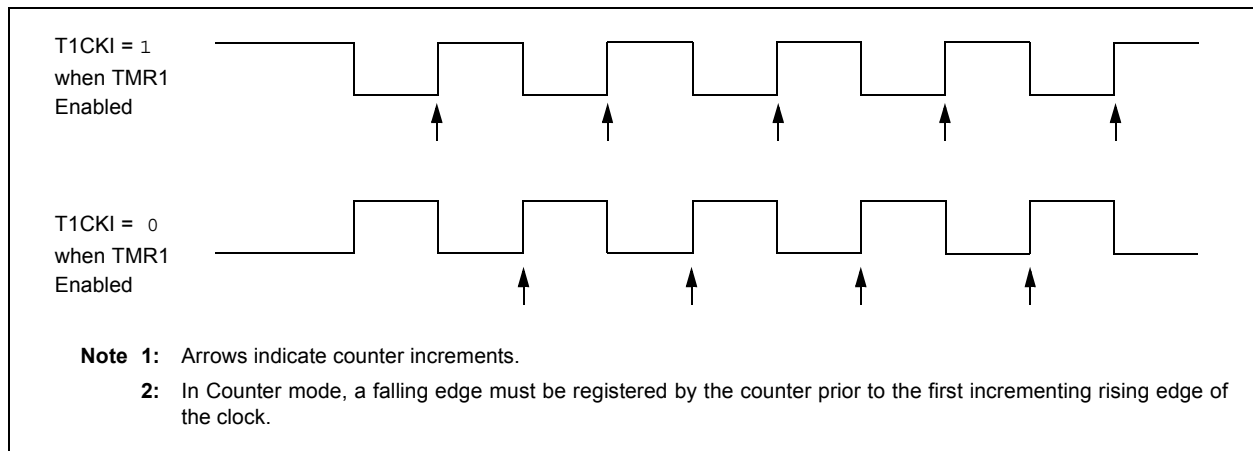
In this mode of operation, the CCPR1H:CCPR1L register pair effectively becomes the period register for Timer1.

Timer1 should be synchronized to the FOSC to utilize the Special Event Trigger. Asynchronous operation of Timer1 can cause a Special Event Trigger to be missed.

In the event that a write to TMR1H or TMR1L coincides with a Special Event Trigger from the ECCP, the write will take precedence.

For more information, see **Section 8.0 “Enhanced Capture/Compare/PWM Module”**.

**FIGURE 5-2: TIMER1 INCREMENTING EDGE**



# PIC16F716

## 5.10 Timer1 Control Register

The Timer1 Control register (T1CON), shown in Register 5-1, is used to control Timer1 and select the various features of the Timer1 module.

**REGISTER 5-1: T1CON: TIMER 1 CONTROL REGISTER**

U-0	U-0	R/W-0	R/W-0	R/W-0	R/W-0	R/W-0	R/W-0
—	—	T1CKPS1	T1CKPS0	T1OSCEN	$\overline{T1SYNC}$	TMR1CS	TMR1ON
bit 7							bit 0

**Legend:**

R = Readable bit

W = Writable bit

U = Unimplemented bit, read as '0'

-n = Value at POR

'1' = Bit is set

'0' = Bit is cleared

x = Bit is unknown

- bit 7-6      **Unimplemented:** Read as '0'
- bit 5-4      **T1CKPS<1:0>:** Timer1 Input Clock Prescale Select bits  
11 = 1:8 Prescale Value  
10 = 1:4 Prescale Value  
01 = 1:2 Prescale Value  
00 = 1:1 Prescale Value
- bit 3        **T1OSCEN:** Timer1 Oscillator Enable Control bit  
1 = Timer1 oscillator is enabled  
0 = Timer1 oscillator is disabled
- bit 2        **T1SYNC:** Timer1 External Clock Input Synchronization Control bit  
TMR1CS = 1:  
1 = Do not synchronize external clock input  
0 = Synchronize external clock input  
TMR1CS = 0:  
This bit is ignored. Timer1 uses the internal clock
- bit 1        **TMR1CS:** Timer1 Clock Source Select bit  
1 = External clock from T1CKI pin (on the rising edge)  
0 = Internal clock (FOSC/4)
- bit 0        **TMR1ON:** Timer1 On bit  
1 = Enables Timer1  
0 = Stops Timer1

**TABLE 5-1: SUMMARY OF REGISTERS ASSOCIATED WITH TIMER1**

Name	Bit 7	Bit 6	Bit 5	Bit 4	Bit 3	Bit 2	Bit 1	Bit 0	Value on POR, BOR	Value on all other Resets
INTCON	GIE	PEIE	T0IE	INTE	RBIE	T0IF	INTF	RBIF	0000 000x	0000 000x
PIE1	—	ADIE	—	—	—	CCP1IE	TMR2IE	TMR1IE	-0-- -000	-0-- -000
PIR1	—	ADIF	—	—	—	CCP1IF	TMR2IF	TMR1IF	-0-- -000	-0-- -000
TMR1H	Holding Register for the Most Significant Byte of the 16-bit TMR1 Register								xxxx xxxx	uuuu uuuu
TMR1L	Holding Register for the Least Significant Byte of the 16-bit TMR1 Register								xxxx xxxx	uuuu uuuu
T1CON	—	—	T1CKPS1	T1CKPS0	T1OSCEN	T1SYNC	TMR1CS	TMR1ON	--00 0000	--uu uuuu

**Legend:** x = unknown, u = unchanged, - = unimplemented, read as '0'. Shaded cells are not used by the Timer1 module.

# PIC16F716

---

NOTES:

## 6.0 TIMER2 MODULE

The Timer2 module is an 8-bit timer with the following features:

- 8-bit timer register (TMR2)
- 8-bit period register (PR2)
- Interrupt on TMR2 match with PR2
- Software programmable prescaler (1:1, 1:4, 1:16)
- Software programmable postscaler (1:1 to 1:16)

See Figure 6-1 for a block diagram of Timer2.

### 6.1 Timer2 Operation

The clock input to the Timer2 module is the system instruction clock ( $F_{osc}/4$ ). The clock is fed into the Timer2 prescaler, which has prescale options of 1:1, 1:4 or 1:16. The output of the prescaler is then used to increment the TMR2 register.

The values of TMR2 and PR2 are constantly compared to determine when they match. TMR2 will increment from 00h until it matches the value in PR2. When a match occurs, two things happen:

- TMR2 is reset to 00h on the next increment cycle
- The Timer2 postscaler is incremented

The match output of the Timer2/PR2 comparator is then fed into the Timer2 postscaler. The postscaler has postscale options of 1:1 to 1:16 inclusive. The output of the Timer2 postscaler is used to set the TMR2IF interrupt flag bit in the PIR2 register.

The TMR2 and PR2 registers are both fully readable and writable. On any Reset, the TMR2 register is set to 00h and the PR2 register is set to FFh.

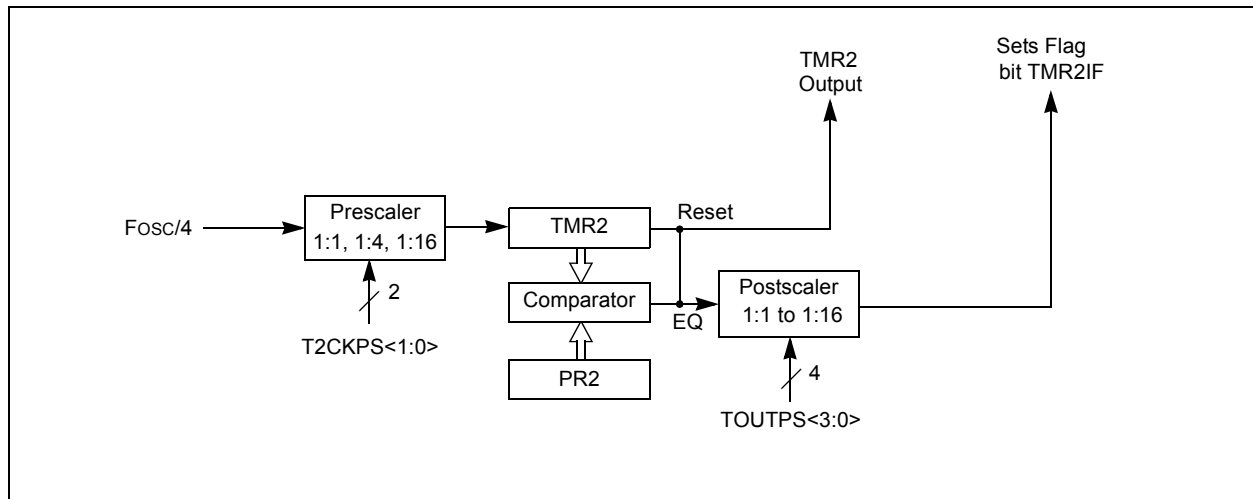
Timer2 is turned on by setting the TMR2ON bit in the T2CON register to a '1'. Timer2 is turned off by clearing the TMR2ON bit to a '0'.

The Timer2 prescaler is controlled by the T2CKPS bits in the T2CON register. The Timer2 postscaler is controlled by the TOUTPS bits in the T2CON register. The prescaler and postscaler counters are cleared when:

- A write to TMR2 occurs.
- A write to T2CON occurs.
- Any device Reset occurs (Power-on Reset,  $\overline{MCLR}$  Reset, Watchdog Timer Reset, or Brown-out Reset).

**Note:** TMR2 is not cleared when T2CON is written.

**FIGURE 6-1: TIMER2 BLOCK DIAGRAM**



# PIC16F716

## REGISTER 6-1: T2CON: TIMER 2 CONTROL REGISTER

U-0	R/W-0	R/W-0	R/W-0	R/W-0	R/W-0	R/W-0	R/W-0
—	TOUTPS3	TOUTPS2	TOUTPS1	TOUTPS0	TMR2ON	T2CKPS1	T2CKPS0
bit 7							bit 0

### Legend:

R = Readable bit                      W = Writable bit                      U = Unimplemented bit, read as '0'  
 -n = Value at POR                      '1' = Bit is set                      '0' = Bit is cleared                      x = Bit is unknown

bit 7                      **Unimplemented:** Read as '0'

bit 6-3                      **TOUTPS<3:0>:** Timer2 Output Postscaler Select bits  
 0000 = 1:1 Postscaler  
 0001 = 1:2 Postscaler  
 0010 = 1:3 Postscaler  
 0011 = 1:4 Postscaler  
 0100 = 1:5 Postscaler  
 0101 = 1:6 Postscaler  
 0110 = 1:7 Postscaler  
 0111 = 1:8 Postscaler  
 1000 = 1:9 Postscaler  
 1001 = 1:10 Postscaler  
 1010 = 1:11 Postscaler  
 1011 = 1:12 Postscaler  
 1100 = 1:13 Postscaler  
 1101 = 1:14 Postscaler  
 1110 = 1:15 Postscaler  
 1111 = 1:16 Postscaler

bit 2                      **TMR2ON:** Timer2 On bit  
 1 = Timer2 is on  
 0 = Timer2 is off

bit 1-0                      **T2CKPS<1:0>:** Timer2 Clock Prescale Select bits  
 00 = Prescaler is 1  
 01 = Prescaler is 4  
 1x = Prescaler is 16

**TABLE 6-1: SUMMARY OF REGISTERS ASSOCIATED WITH TIMER2**

Name	Bit 7	Bit 6	Bit 5	Bit 4	Bit 3	Bit 2	Bit 1	Bit 0	Value on POR, BOR	Value on all other Resets
INTCON	GIE	PEIE	TOIE	INTE	RBIE	TOIF	INTF	RBIF	0000 000x	0000 000x
PIE1	—	ADIE	—	—	—	CCP1IE	TMR2IE	TMR1IE	-0-- -000	-0-- -000
PIR1	—	ADIF	—	—	—	CCP1IF	TMR2IF	TMR1IF	-0-- -000	-0-- -000
PR2	Timer2 Module Period Register								1111 1111	1111 1111
TMR2	Holding Register for the 8-bit TMR2 Register								0000 0000	0000 0000
T2CON	—	TOUTPS3	TOUTPS2	TOUTPS1	TOUTPS0	TMR2ON	T2CKPS1	T2CKPS0	-000 0000	-000 0000

**Legend:** x = unknown, u = unchanged, - = unimplemented read as '0'. Shaded cells are not used for Timer2 module.

## 7.0 ANALOG-TO-DIGITAL CONVERTER (ADC) MODULE

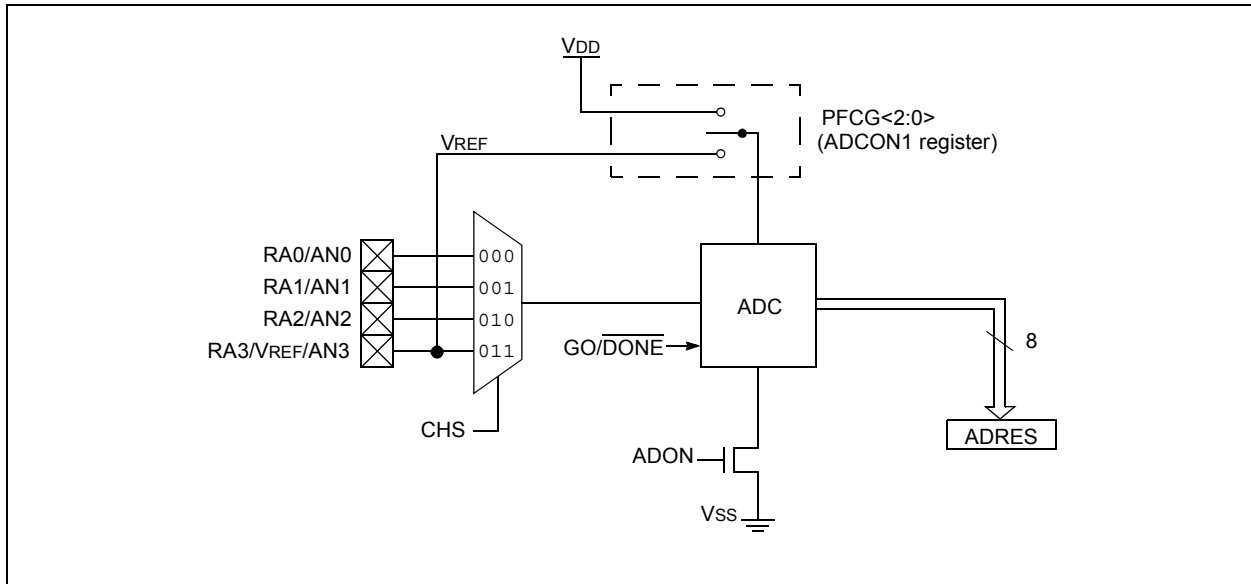
The Analog-to-Digital Converter (ADC) allows conversion of an analog input signal to a 8-bit binary representation of that signal. This device uses analog inputs, which are multiplexed into a single sample and hold circuit. The output of the sample and hold is connected to the input of the converter. The converter generates a 8-bit binary result via successive approximation and stores the conversion result into the ADC result register (ADRES).

The ADC voltage reference is software selectable to either VDD or a voltage applied to the external reference pins.

The ADC can generate an interrupt upon completion of a conversion. This interrupt can be used to wake-up the device from Sleep.

Figure 7-1 shows the block diagram of the ADC.

**FIGURE 7-1: ADC BLOCK DIAGRAM**



# PIC16F716

## 7.1 ADC Configuration

When configuring and using the ADC the following functions must be considered:

- Port configuration
- Channel selection
- ADC voltage reference selection
- ADC conversion clock source
- Interrupt control

### 7.1.1 PORT CONFIGURATION

The ADC can be used to convert both analog and digital signals. When converting analog signals, the I/O pin should be configured for analog by setting the associated TRIS and ADCON1 bits. See the corresponding Port section for more information.

**Note:** Analog voltages on any pin that is defined as a digital input may cause the input buffer to conduct excess current.

### 7.1.2 CHANNEL SELECTION

The CHS bits of the ADCON0 register determine which channel is connected to the sample and hold circuit.

When changing channels, a delay is required before starting the next conversion. Refer to **Section 7.2 “ADC Operation”** for more information.

### 7.1.3 ADC VOLTAGE REFERENCE

The PCFG bits of the ADCON0 register provide independent control of the positive voltage reference. The positive voltage reference can be either VDD or an external voltage source.

### 7.1.4 CONVERSION CLOCK

The source of the conversion clock is software selectable via the ADCS bits of the ADCON0 register. There are four possible clock options:

- FOSC/2
- FOSC/8
- FOSC/32
- FRC (dedicated internal oscillator)

The time to complete one bit conversion is defined as TAD. One full 8-bit conversion requires 9.5 TAD periods.

For correct conversion, the appropriate TAD specification must be met. See A/D conversion requirements in **Section 12.0 “Electrical Characteristics”** for more information. Table 7-1 gives examples of appropriate ADC clock selections.

**Note:** Unless using the FRC, any changes in the system clock frequency will change the ADC clock frequency, which may adversely affect the ADC result.

**TABLE 7-1: TAD vs. DEVICE OPERATING FREQUENCIES**

AD Clock Source (TAD)		Device Frequency			
Operation	ADCS<1:0>	20 MHz	5 MHz	1.25 MHz	333.33 kHz
2 TOSC	00	100 ns <sup>(2)</sup>	400 ns <sup>(2)</sup>	1.6 μs	6 μs
8 TOSC	01	400 ns <sup>(2)</sup>	1.6 μs	6.4 μs	24 μs <sup>(3)</sup>
32 TOSC	10	1.6 μs	6.4 μs	25.6 μs <sup>(3)</sup>	96 μs <sup>(3)</sup>
RC	11	2-6 μs <sup>(1), (4)</sup>	2-6 μs <sup>(1), (4)</sup>	2-6 μs <sup>(1), (4)</sup>	2-6 μs <sup>(1)</sup>

**Legend:** Shaded cells are outside of recommended range.

**Note 1:** The RC source has a typical TAD time of 4 μs.

**2:** These values violate the minimum required TAD time.

**3:** For faster conversion times, the selection of another clock source is recommended.

**4:** When device frequency is greater than 1 MHz, the RC A/D conversion clock source is recommended for Sleep operation only.

## 7.1.5 INTERRUPTS

The ADC module allows for the ability to generate an interrupt upon completion of an Analog-to-Digital conversion. The ADC interrupt flag is the ADIF bit in the PIR1 register. The ADC interrupt enable is the ADIE bit in the PIE1 register. The ADIF bit must be cleared in software.

<p><b>Note:</b> The ADIF bit is set at the completion of every conversion, regardless of whether or not the ADC interrupt is enabled.</p>
---

This interrupt can be generated while the device is operating or while in Sleep. If the device is in Sleep, the interrupt will wake-up the device. Upon waking from Sleep, the next instruction following the `SLEEP` instruction is always executed. If the user is attempting to wake-up from Sleep and resume in-line code execution, the global interrupt must be disabled. If the global interrupt is enabled, execution will switch to the Interrupt Service Routine.

Please see **Section 7.1.5 “Interrupts”** for more information.

# PIC16F716

## 7.2 ADC Operation

### 7.2.1 STARTING A CONVERSION

To enable the ADC module, the ADON bit of the  $\overline{\text{ADCON0}}$  register must be set to a '1'. Setting the  $\overline{\text{GO/DONE}}$  bit of the  $\overline{\text{ADCON0}}$  register to a '1' will start the Analog-to-Digital conversion.

**Note:** The  $\overline{\text{GO/DONE}}$  bit should not be set in the same instruction that turns on the ADC. Refer to **Section 7.2.6 “A/D Conversion Procedure”**.

### 7.2.2 COMPLETION OF A CONVERSION

When the conversion is complete, the ADC module will:

- Clear the  $\overline{\text{GO/DONE}}$  bit
- Set the ADIF flag bit
- Update the ADRES register with new conversion result

### 7.2.3 TERMINATING A CONVERSION

If a conversion must be terminated before completion, the  $\overline{\text{GO/DONE}}$  bit can be cleared in software. The ADRES register will not be updated with the partially complete Analog-to-Digital conversion sample. Instead, the ADRES register will retain the value of the previous conversion. Additionally, a 2 TAD delay is required before another acquisition can be initiated. Following this delay, an input acquisition is automatically started on the selected channel.

**Note:** A device Reset forces all registers to their Reset state. Thus, the ADC module is turned off and any pending conversion is terminated.

### 7.2.4 ADC OPERATION DURING SLEEP

The ADC module can operate during Sleep. This requires the ADC clock source to be set to the FRC option. When the FRC clock source is selected, the ADC waits one additional instruction before starting the conversion. This allows the `SLEEP` instruction to be executed, which can reduce system noise during the conversion. If the ADC interrupt is enabled, the device will wake-up from Sleep when the conversion completes. If the ADC interrupt is disabled, the ADC module is turned off after the conversion completes, although the ADON bit remains set.

When the ADC clock source is something other than FRC, a `SLEEP` instruction causes the present conversion to be aborted and the ADC module is turned off, although the ADON bit remains set.

### 7.2.5 SPECIAL EVENT TRIGGER

The ECCP Special Event Trigger allows periodic ADC measurements without software intervention. When this trigger occurs, the  $\overline{\text{GO/DONE}}$  bit is set by hardware and the Timer1 counter resets to zero.

Using the Special Event Trigger does not assure proper ADC timing. It is the user's responsibility to ensure that the ADC timing requirements are met.

See **Section 8.0 “Enhanced Capture/Compare/PWM Module”** for more information.

### 7.2.6 A/D CONVERSION PROCEDURE

This is an example procedure for using the ADC to perform an Analog-to-Digital conversion:

1. Configure Port:
  - Disable pin output driver (See TRIS register)
  - Configure pin as analog
2. Configure the ADC module:
  - Select ADC conversion clock
  - Configure voltage reference
  - Select ADC input channel
  - Select result format
  - Turn on ADC module
3. Configure ADC interrupt (optional):
  - Clear ADC interrupt flag
  - Enable ADC interrupt
  - Enable peripheral interrupt
  - Enable global interrupt<sup>(1)</sup>
4. Wait the required acquisition time<sup>(2)</sup>.
5. Start conversion by setting the  $\overline{\text{GO/DONE}}$  bit.
6. Wait for ADC conversion to complete by one of the following:
  - Polling the  $\overline{\text{GO/DONE}}$  bit
  - Waiting for the ADC interrupt (interrupts enabled)
7. Read ADC Result
8. Clear the ADC interrupt flag (required if interrupt is enabled).

**Note 1:** The global interrupt can be disabled if the user is attempting to wake-up from Sleep and resume in-line code execution.

**2:** See **Section 7.3 “A/D Acquisition Requirements”**.

## 7.2.7 ADC REGISTER DEFINITIONS

The following registers are used to control the operation of the ADC.

### REGISTER 7-1: ADCON0: A/D CONTROL REGISTER 0

R/W-0	R/W-0	R/W-0	R/W-0	R/W-0	R/W-0	U-0	R/W-0
ADCS1	ADCS0	CHS2	CHS1	CHS0	GO/DONE	—	ADON
bit 7						bit 0	

#### Legend:

R = Readable bit	W = Writable bit	U = Unimplemented bit, read as '0'
-n = Value at POR	'1' = Bit is set	'0' = Bit is cleared
		x = Bit is unknown

- bit 7-6      **ADCS<1:0>**: A/D Conversion Clock Select bits  
 00 = FOSC/2  
 01 = FOSC/8  
 10 = FOSC/32  
 11 = FRC (Clock derived from the internal ADC RC oscillator)
- bit 5-3      **CHS<2:0>**: Analog Channel Select bits  
 000 = AN0  
 001 = AN1  
 010 = AN2  
 011 = AN3  
 100 = Reserved, do not use  
 101 = Reserved, do not use  
 110 = Reserved, do not use  
 111 = Reserved, do not use
- bit 2      **GO/DONE**: A/D Conversion Status bit  
 1 = A/D conversion cycle in progress. Setting this bit starts an A/D conversion cycle.  
 This bit is automatically cleared by hardware when the A/D conversion has completed.  
 0 = A/D conversion completed/not in progress
- bit 1      **Unimplemented**: Read as '0'
- bit 0      **ADON**: ADC Enable bit  
 1 = ADC is enabled  
 0 = ADC is disabled and consumes no operating current

# PIC16F716

## REGISTER 7-2: ADCON1: A/D CONTROL REGISTER 1

U-0	U-0	U-0	U-0	U-0	R/W-0	R/W-0	R/W-0
—	—	—	—	—	PCFG2	PCFG1	PCFG0
bit 7					bit 0		

### Legend:

R = Readable bit                      W = Writable bit                      U = Unimplemented bit, read as '0'  
 -n = Value at POR                      '1' = Bit is set                      '0' = Bit is cleared                      x = Bit is unknown

bit 7-3                      **Unimplemented:** Read as '0'

bit 2-0                      **PCFG<2:0>:** A/D Port Configuration Control bits.

The following table illustrates the effects of the various configurations:

PCFG<2:0>	AN3/ RA3	AN2/ RA2	AN1/ RA1	AN0/ RA0	VREF
0x0	A	A	A	A	VDD
0x1	VREF	A	A	A	RA3
100	A	D	A	A	VDD
101	VREF	D	A	A	RA3
11x	D	D	D	D	VDD

**Legend:** A = Analog input, D = Digital I/O

## 7.3 A/D Acquisition Requirements

For the ADC to meet its specified accuracy, the charge holding capacitor (CHOLD) must be allowed to fully charge to the input channel voltage level. The Analog Input model is shown in Figure 7-2. The source impedance (Rs) and the internal sampling switch (Rss) impedance directly affect the time required to charge the capacitor CHOLD. The sampling switch (Rss) impedance varies over the device voltage (VDD), see Figure 7-2. **The maximum recommended impedance for analog sources is 10 kΩ.** As the source impedance is decreased, the acquisition time may be decreased. After the analog input channel is selected (or changed),

an A/D acquisition must be done before the conversion can be started. To calculate the minimum acquisition time, Equation 7-1 may be used. This equation assumes that 1/2 LSB error is used. The 1/2 LSB error is the maximum error allowed for the ADC to meet its specified resolution.

### EQUATION 7-1: ACQUISITION TIME EXAMPLE

*Assumptions: Temperature = 50°C and external impedance of 10kΩ 5.0V VDD*

$$\begin{aligned} T_{ACQ} &= \text{Amplifier Settling Time} + \text{Hold Capacitor Charging Time} + \text{Temperature Coefficient} \\ &= T_{AMP} + T_C + T_{COFF} \\ &= 2\mu s + T_C + [(Temperature - 25^\circ C)(0.05\mu s/^\circ C)] \end{aligned}$$

*The value for TC can be approximated with the following equations:*

$$V_{APPLIED} \left( 1 - \frac{1}{2047} \right) = V_{CHOLD} \quad ;[1] \text{ } V_{CHOLD} \text{ charged to within } 1/2 \text{ lsb}$$

$$V_{APPLIED} \left( 1 - e^{-\frac{T_C}{RC}} \right) = V_{CHOLD} \quad ;[2] \text{ } V_{CHOLD} \text{ charge response to } V_{APPLIED}$$

$$V_{APPLIED} \left( 1 - e^{-\frac{T_C}{RC}} \right) = V_{APPLIED} \left( 1 - \frac{1}{2047} \right) \quad ;\text{combining [1] and [2]}$$

*Solving for TC:*

$$\begin{aligned} T_C &= -CHOLD(RIC + R_{SS} + R_S) \ln(1/2047) \\ &= -10pF(1k\Omega + 7k\Omega + 10k\Omega) \ln(0.0004885) \\ &= 1.37\mu s \end{aligned}$$

*Therefore:*

$$\begin{aligned} T_{ACQ} &= 2\mu s + 1.37\mu s + [(50^\circ C - 25^\circ C)(0.05\mu s/^\circ C)] \\ &= 4.67\mu s \end{aligned}$$

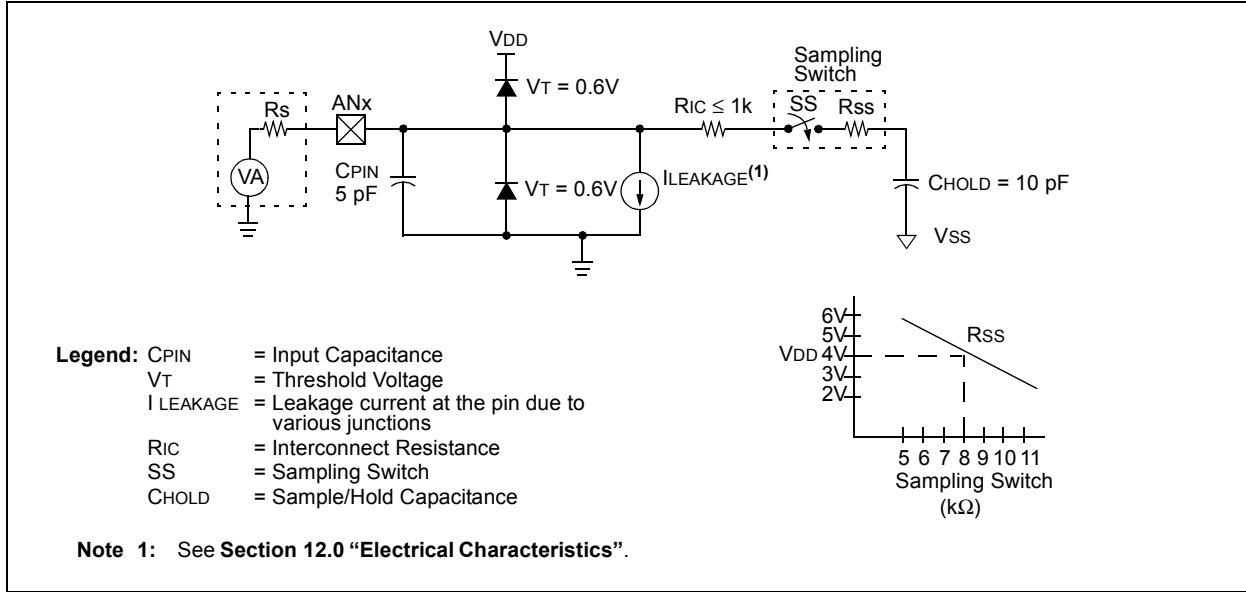
**Note 1:** The reference voltage (VREF) has no effect on the equation, since it cancels itself out.

**2:** The charge holding capacitor (CHOLD) is not discharged after each conversion.

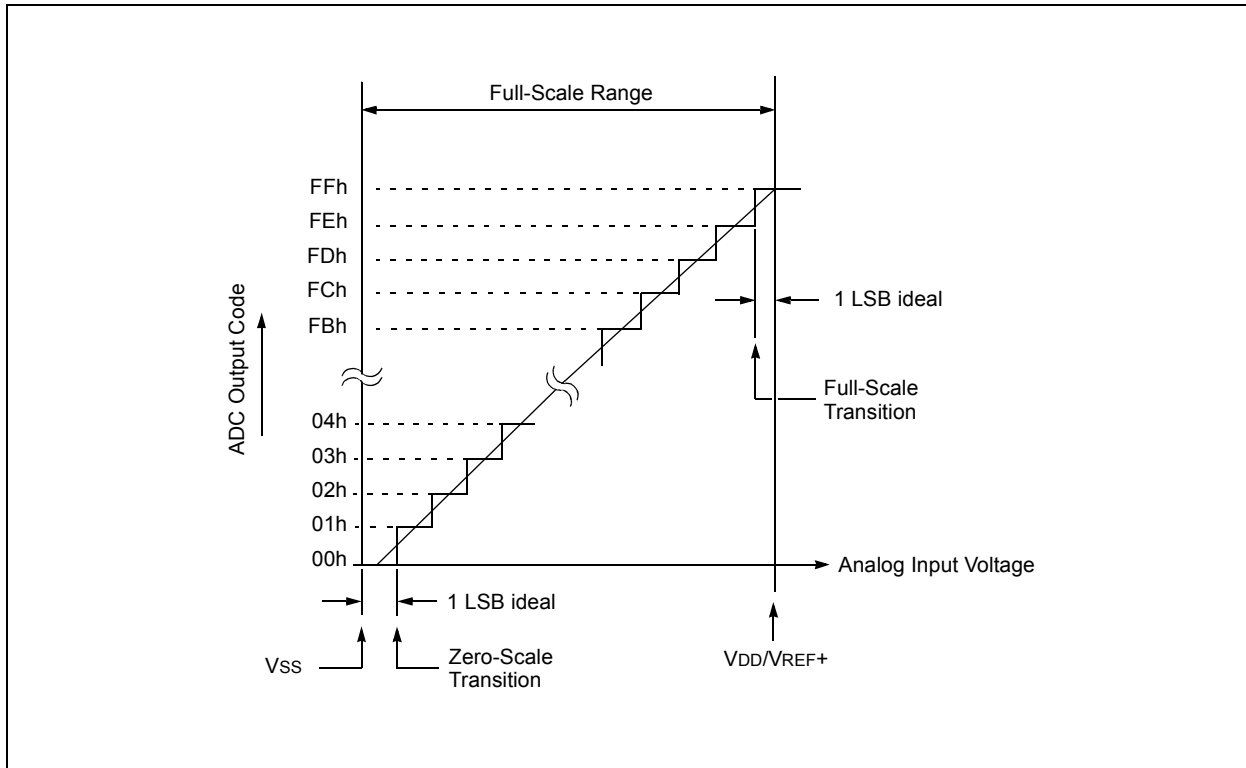
**3:** The maximum recommended impedance for analog sources is 10 kΩ. This is required to meet the pin leakage specification.

# PIC16F716

**FIGURE 7-2: ANALOG INPUT MODEL**



**FIGURE 7-3: ADC TRANSFER FUNCTION**



**TABLE 7-2: SUMMARY OF ASSOCIATED ADC REGISTERS**

Name	Bit 7	Bit 6	Bit 5	Bit 4	Bit 3	Bit 2	Bit 1	Bit 0	Value on POR, BOR	Value on all other Resets
ADCON0	ADCS1	ADCS0	CHS2	CHS1	CHS0	GO/DONE	—	ADON	0000 0000	0000 0000
ADCON1	—	—	—	—	—	PCFG2	PCFG1	PCFG0	---- -000	---- -000
ADRES	A/D Result Register								xxxx xxxx	uuuu uuuu
INTCON	GIE	PEIE	T0IE	INTE	RBIE	T0IF	INTF	RBIF	0000 000x	0000 000x
PIE1	—	ADIE	—	—	—	CCP1IE	TMR2IE	TMR1IE	-0-- -000	-0-- -000
PIR1	—	ADIF	—	—	—	CCP1IF	TMR2IF	TMR1IF	-0-- -000	-0-- -000
PORTA	—	—	—	RA4	RA3	RA2	RA1	RA0	--xx xxxx	--uu uuuu
TRISA	—	—	—	TRISA4	TRISA3	TRISA2	TRISA1	TRISA0	--11 1111	--11 1111

**Legend:** x = unknown, u = unchanged, — = unimplemented read as '0'. Shaded cells are not used for ADC module.

# PIC16F716

---

NOTES:

## 8.0 ENHANCED CAPTURE/ COMPARE/PWM MODULE

The Enhanced Capture/Compare/PWM module is a peripheral which allows the user to time and control different events. In Capture mode, the peripheral allows the timing of the duration of an event. The Compare mode allows the user to trigger an external event when a predetermined amount of time has expired. The PWM mode can generate a Pulse-Width Modulated signal of varying frequency and duty cycle.

Table 8-1 shows the timer resources required by the ECCP module.

**Note:** CCPR1 and CCP1 throughout this document refer to CCPR1 or CCPR2 and CCP1 or CCP2, respectively.

**TABLE 8-1: ECCP MODE – TIMER RESOURCES REQUIRED**

ECCP Mode	Timer Resource
Capture	Timer1
Compare	Timer1
PWM	Timer2

### REGISTER 8-1: CCP1CON: ENHANCED CCP1 CONTROL REGISTER

R/W-0	R/W-0	R/W-0	R/W-0	R/W-0	R/W-0	R/W-0	R/W-0
P1M1	P1M0	DC1B1	DC1B0	CCP1M3	CCP1M2	CCP1M1	CCP1M0
bit 7							bit 0

**Legend:**

R = Readable bit                      W = Writable bit                      U = Unimplemented bit, read as '0'  
 -n = Value at POR                      '1' = Bit is set                      '0' = Bit is cleared                      x = Bit is unknown

- bit 7-6      **P1M<1:0>**: PWM Output Configuration bits  
 If CCP1M<3:2> = 00, 01, 10:  
 xx = P1A assigned as Capture/Compare input; P1B, P1C, P1D assigned as port pins  
 If CCP1M<3:2> = 11:  
 00 = Single output; P1A modulated; P1B, P1C, P1D assigned as port pins  
 01 = Full-Bridge output forward; P1D modulated; P1A active; P1B, P1C inactive  
 10 = Half-Bridge output; P1A, P1B modulated with dead-band control; P1C, P1D assigned as port pins  
 11 = Full-Bridge output reverse; P1B modulated; P1C active; P1A, P1D inactive
- bit 5-4      **DC1B<1:0>**: PWM Duty Cycle Least Significant bits  
Capture mode:  
 Unused.  
Compare mode:  
 Unused.  
PWM mode:  
 These bits are the two LSBs of the PWM duty cycle. The eight MSBs are found in CCPR1L.
- bit 3-0      **CCP1M<3:0>**: ECCP Mode Select bits  
 0000 = Capture/Compare/PWM off (resets ECCP module)  
 0001 = Unused (reserved)  
 0010 = Compare mode, toggle output on match (CCP1IF bit is set)  
 0011 = Unused (reserved)  
 0100 = Capture mode, every falling edge  
 0101 = Capture mode, every rising edge  
 0110 = Capture mode, every 4th rising edge  
 0111 = Capture mode, every 16th rising edge  
 1000 = Compare mode, set output on match (CCP1IF bit is set)  
 1001 = Compare mode, clear output on match (CCP1IF bit is set)  
 1010 = Compare mode, generate software interrupt on match (CCP1IF bit is set, CCP1 pin is unaffected)  
 1011 = Compare mode, Special Event Trigger (CCP1IF bit is set; CCP1 resets TMR1 or TMR2)  
 1100 = PWM mode; P1A, P1C active-high; P1B, P1D active-high  
 1101 = PWM mode; P1A, P1C active-high; P1B, P1D active-low  
 1110 = PWM mode; P1A, P1C active-low; P1B, P1D active-high  
 1111 = PWM mode; P1A, P1C active-low; P1B, P1D active-low

# PIC16F716

## 8.1 Capture Mode

In Capture mode, CCPR1H:CCPR1L captures the 16-bit value of the TMR1 register when an event occurs on pin CCP1. An event is defined as one of the following and is configured by the CCP1M<3:0> bits of the CCP1CON register:

- Every falling edge
- Every rising edge
- Every 4th rising edge
- Every 16th rising edge

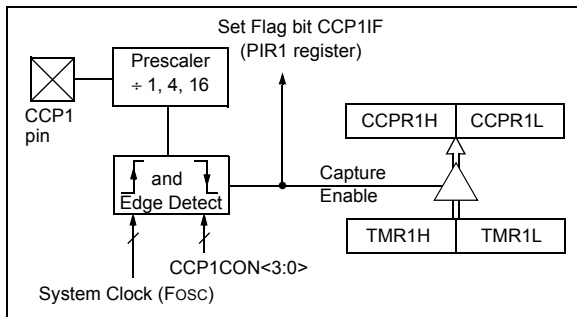
When a capture is made, the Interrupt Request Flag bit CCP1IF of the PIR1 register is set. The interrupt flag must be cleared in software. If another capture occurs before the value in the CCPR1H, CCPR1L register pair is read, the old captured value is overwritten by the new captured value (see Figure 8-1).

### 8.1.1 CCP1 PIN CONFIGURATION

In Capture mode, the CCP1 pin should be configured as an input by setting the associated TRIS control bit.

**Note:** If the CCP1 pin is configured as an output, a write to the port can cause a capture condition.

**FIGURE 8-1: CAPTURE MODE OPERATION BLOCK DIAGRAM**



### 8.1.2 TIMER1 MODE SELECTION

Timer1 must be running in Timer mode or Synchronized Counter mode for the CCP module to use the capture feature. In Asynchronous Counter mode, the capture operation may not work.

### 8.1.3 SOFTWARE INTERRUPT

When the Capture mode is changed, a false capture interrupt may be generated. The user should keep the CCP1IE interrupt enable bit of the PIE1 register clear to avoid false interrupts. Additionally, the user should clear the CCP1IF interrupt flag bit of the PIR1 register following any change in operating mode.

### 8.1.4 CCP PRESCALER

There are four prescaler settings specified by the CCP1M<3:0> bits of the CCP1CON register. Whenever the CCP module is turned off, or the CCP module is not in Capture mode, the prescaler counter is cleared. Any Reset will clear the prescaler counter.

Switching from one capture prescaler to another does not clear the prescaler and may generate a false interrupt. To avoid this unexpected operation, turn the module off by clearing the CCP1CON register before changing the prescaler (see Example 8-1).

**EXAMPLE 8-1: CHANGING BETWEEN CAPTURE PRESCALERS**

```

BANKSEL CCP1CON    ;Set Bank bits to point
                   ;to CCP1CON
CLRWF  CCP1CON     ;Turn CCP module off
MOVLW  NEW_CAPT_PS ;Load the W reg with
                   ; the new prescaler
MOVWF  CCP1CON     ; move value and CCP ON
MOVWF  CCP1CON     ;Load CCP1CON with this
                   ; value
    
```

**TABLE 8-2: REGISTERS ASSOCIATED WITH CAPTURE**

Name	Bit 7	Bit 6	Bit 5	Bit 4	Bit 3	Bit 2	Bit 1	Bit 0	Value on POR, BOR	Value on all other Resets
CCPR1L	Capture/Compare/PWM Register 1 (LSB)								xxxx xxxx	xxxx xxxx
CCPR1H	Capture/Compare/PWM Register 1 (MSB)								xxxx xxxx	xxxx xxxx
CCP1CON	P1M1	P1M0	DC1B1	DC1B0	CCP1M3	CCP1M2	CCP1M1	CCP1M0	0000 0000	0000 0000
INTCON	GIE	PEIE	T0IE	INTE	RBIE	T0IF	INTF	RBIF	0000 000x	0000 000x
PIE1	—	ADIE	—	—	—	CCP1IE	TMR2IE	TMR1IE	-0-- -000	-0-- -000
PIR1	—	ADIF	—	—	—	CCP1IF	TMR2IF	TMR1IF	-0-- -000	-0-- -000
PR2	Timer2 Period Register								1111 1111	1111 1111
TMR1L	Holding Register for the Least Significant Byte of the 16-bit TMR1 Register								xxxx xxxx	xxxx xxxx
TMR1H	Holding Register for the Most Significant Byte of the 16-bit TMR1 Register								xxxx xxxx	xxxx xxxx
TMR2	Timer2 module's register								0000 0000	0000 0000
TRISB	TRISB7	TRISB6	TRISB5	TRISB4	TRISB3	TRISB2	TRISB1	TRISB0	1111 1111	1111 1111

**Legend:** — = Unimplemented locations, read as '0', u = unchanged, x = unknown. Shaded cells are not used by the Capture.

# PIC16F716

## 8.2 Compare Mode

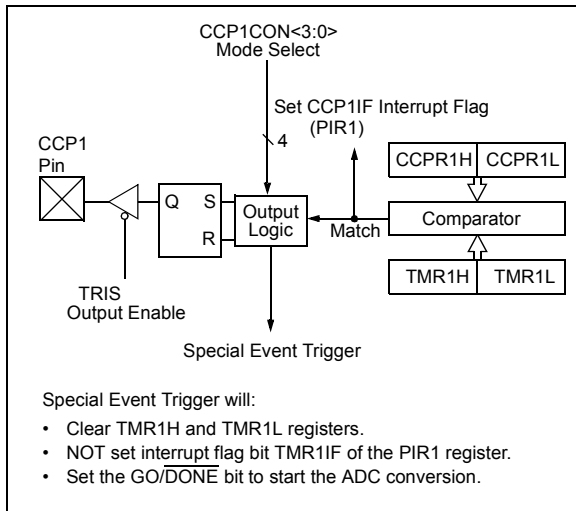
In Compare mode, the 16-bit CCPR1 register value is constantly compared against the TMR1 register pair value. When a match occurs, the CCP1 module may:

- Toggle the CCP1 output.
- Set the CCP1 output.
- Clear the CCP1 output.
- Generate a Special Event Trigger.
- Generate a Software Interrupt.

The action on the pin is based on the value of the CCP1M<3:0> control bits of the CCP1CON register.

All Compare modes can generate an interrupt.

**FIGURE 8-2: COMPARE MODE OPERATION BLOCK DIAGRAM**



### 8.2.1 CCP1 PIN CONFIGURATION

The user must configure the CCP1 pin as an output by clearing the associated TRIS bit.

**Note:** Clearing the CCP1CON register will force the CCP1 compare output latch to the default low level. This is not the PORT I/O data latch.

### 8.2.2 TIMER1 MODE SELECTION

In Compare mode, Timer1 must be running in either Timer mode or Synchronized Counter mode. The compare operation may not work in Asynchronous Counter mode.

### 8.2.3 SOFTWARE INTERRUPT MODE

When Generate Software Interrupt mode is chosen (CCP1M<3:0> = 1010), the CCP1 module does not assert control of the CCP1 pin (see the CCP1CON register).

### 8.2.4 SPECIAL EVENT TRIGGER

When Special Event Trigger mode is chosen (CCP1M<3:0> = 1011), the CCP1 module does the following:

- Resets Timer1
- Starts an ADC conversion if ADC is enabled

The CCP1 module does not assert control of the CCP1 pin in this mode (see the CCP1CON register).

The Special Event Trigger output of the CCP occurs immediately upon a match between the TMR1H, TMR1L register pair and the CCPR1H, CCPR1L register pair. The TMR1H, TMR1L register pair is not reset until the next rising edge of the Timer1 clock. This allows the CCPR1H, CCPR1L register pair to effectively provide a 16-bit programmable period register for Timer1.

**Note 1:** The Special Event Trigger from the CCP module does not set interrupt flag bit TMRxIF of the PIR1 register.

- 2: Removing the match condition by changing the contents of the CCPR1H and CCPR1L register pair, between the clock edge that generates the Special Event Trigger and the clock edge that generates the Timer1 Reset, will preclude the Reset from occurring.

**TABLE 8-3: REGISTERS ASSOCIATED WITH COMPARE**

Name	Bit 7	Bit 6	Bit 5	Bit 4	Bit 3	Bit 2	Bit 1	Bit 0	Value on POR, BOR	Value on all other Resets
CCPR1L	Capture/Compare/PWM Register 1 (LSB)								xxxx xxxx	xxxx xxxx
CCPR1H	Capture/Compare/PWM Register 1 (MSB)								xxxx xxxx	xxxx xxxx
CCP1CON	P1M1	P1M0	DC1B1	DC1B0	CCP1M3	CCP1M2	CCP1M1	CCP1M0	0000 0000	0000 0000
INTCON	GIE	PEIE	T0IE	INTE	RBIE	T0IF	INTF	RBIF	0000 000x	0000 000x
PIE1	—	ADIE	—	—	—	CCP1IE	TMR2IE	TMR1IE	-0-- -000	-0-- -000
PIR1	—	ADIF	—	—	—	CCP1IF	TMR2IF	TMR1IF	-0-- -000	-0-- -000
PR2	Timer2 Period Register								1111 1111	1111 1111
TMR1L	Holding Register for the Least Significant Byte of the 16-bit TMR1 Register								xxxx xxxx	xxxx xxxx
TMR1H	Holding Register for the Most Significant Byte of the 16-bit TMR1 Register								xxxx xxxx	xxxx xxxx
TMR2	Timer2 module's register								0000 0000	0000 0000
TRISB	TRISB7	TRISB6	TRISB5	TRISB4	TRISB3	TRISB2	TRISB1	TRISB0	1111 1111	1111 1111

**Legend:** — = Unimplemented locations, read as '0', u = unchanged, x = unknown. Shaded cells are not used by the Compare.

# PIC16F716

## 8.3 PWM Mode

The PWM mode generates a Pulse-Width Modulated signal on the CCP1 pin. The duty cycle, period and resolution are determined by the following registers:

- PR2
- T2CON
- CCPR1L
- CCP1CON

In Pulse-Width Modulation (PWM) mode, the CCP module produces up to a 10-bit resolution PWM output on the CCP1 pin. Since the CCP1 pin is multiplexed with the PORT data latch, the TRIS for that pin must be cleared to enable the CCP1 pin output driver.

**Note:** Clearing the CCP1CON register will relinquish CCP1 control of the CCP1 pin.

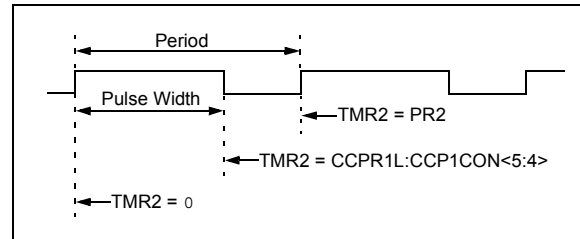
Figure 8-3 shows a simplified block diagram of PWM operation.

Figure 8-4 shows a typical waveform of the PWM signal.

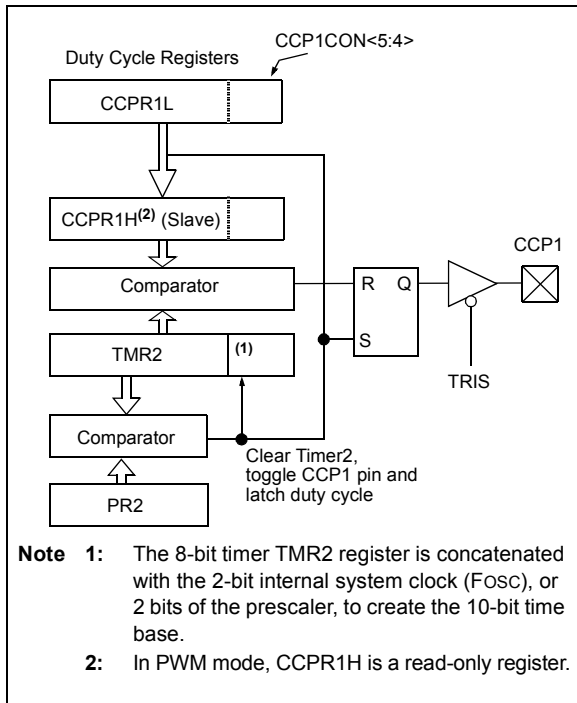
For a step-by-step procedure on how to set up the CCP module for PWM operation, see **Section 8.3.7 “Setup for PWM Operation”**.

The PWM output (Figure 8-4) has a time base (period) and a time that the output stays high (duty cycle).

**FIGURE 8-4: CCP PWM OUTPUT**



**FIGURE 8-3: SIMPLIFIED PWM BLOCK DIAGRAM**



## 8.3.1 PWM PERIOD

The PWM period is specified by the PR2 register of Timer2. The PWM period can be calculated using the formula of Equation 8-1.

### EQUATION 8-1: PWM PERIOD

$$PWM\ Period = [(PR2) + 1] \cdot 4 \cdot TOSC \cdot (TMR2\ Prescale\ Value)$$

When TMR2 is equal to PR2, the following three events occur on the next increment cycle:

- TMR2 is cleared
- The CCP1 pin is set. (Exception: If the PWM duty cycle = 0%, the pin will not be set.)
- The PWM duty cycle is latched from CCPR1L into CCPR1H.

**Note:** The Timer2 postscaler (see **Section 6.0 “Timer2 Module”**) is not used in the determination of the PWM frequency.

## 8.3.2 PWM DUTY CYCLE

The PWM duty cycle is specified by writing a 10-bit value to multiple registers: CCPR1L register and DC1B<1:0> bits of the CCP1CON register. The CCPR1L contains the eight MSBs and the DC1B<1:0> bits of the CCP1CON register contain the two LSBs. CCPR1L and DC1B<1:0> bits of the CCP1CON register can be written to at any time. The duty cycle value is not latched into CCPR1H until after the period completes (i.e., a match between PR2 and TMR2 registers occurs). While using the PWM, the CCPR1H register is read-only.

Equation 8-2 is used to calculate the PWM pulse width.

Equation 8-3 is used to calculate the PWM duty cycle ratio.

### EQUATION 8-2: PULSE WIDTH

$$Pulse\ Width = (CCPR1L:CCP1CON<5:4>) \cdot TOSC \cdot (TMR2\ Prescale\ Value)$$

### EQUATION 8-3: DUTY CYCLE RATIO

$$Duty\ Cycle\ Ratio = \frac{(CCPR1L:CCP1CON<5:4>)}{4(PR2 + 1)}$$

The CCPR1H register and a 2-bit internal latch are used to double buffer the PWM duty cycle. This double buffering is essential for glitchless PWM operation.

The 8-bit timer TMR2 register is concatenated with either the 2-bit internal system clock (FOSC), or 2 bits of the prescaler, to create the 10-bit time base. The system clock is used if the Timer2 prescaler is set to 1:1.

When the 10-bit time base matches the CCPR1H and 2-bit latch, then the CCP1 pin is cleared (see Figure 8-3).

# PIC16F716

## 8.3.3 PWM RESOLUTION

The resolution determines the number of available duty cycles for a given period. For example, a 10-bit resolution will result in 1024 discrete duty cycles, whereas an 8-bit resolution will result in 256 discrete duty cycles.

The maximum PWM resolution is 10 bits when PR2 is 255. The resolution is a function of the PR2 register value as shown by Equation 8-4.

## EQUATION 8-4: PWM RESOLUTION

$$Resolution = \frac{\log[4(PR2 + 1)]}{\log(2)} \text{ bits}$$

Note: If the pulse width value is greater than the period the assigned PWM pin(s) will remain unchanged.

**TABLE 8-4: EXAMPLE PWM FREQUENCIES AND RESOLUTIONS (Fosc = 20 MHz)**

PWM Frequency	1.22 kHz	4.88 kHz	19.53 kHz	78.12 kHz	156.3 kHz	208.3 kHz
Timer Prescale (1, 4, 16)	16	4	1	1	1	1
PR2 Value	0xFF	0xFF	0xFF	0x3F	0x1F	0x17
Maximum Resolution (bits)	10	10	10	8	7	6.6

**TABLE 8-5: EXAMPLE PWM FREQUENCIES AND RESOLUTIONS (Fosc = 8 MHz)**

PWM Frequency	1.22 kHz	4.90 kHz	19.61 kHz	76.92 kHz	153.85 kHz	200.0 kHz
Timer Prescale (1, 4, 16)	16	4	1	1	1	1
PR2 Value	0x65	0x65	0x65	0x19	0x0C	0x09
Maximum Resolution (bits)	8	8	8	6	5	5

## 8.3.4 OPERATION IN SLEEP MODE

In Sleep mode, the TMR2 register will not increment and the state of the module will not change. If the CCP1 pin is driving a value, it will continue to drive that value. When the device wakes up, TMR2 will continue from its previous state.

## 8.3.5 CHANGES IN SYSTEM CLOCK FREQUENCY

The PWM frequency is derived from the system clock frequency. Any changes in the system clock frequency will result in changes to the PWM frequency.

## 8.3.6 EFFECTS OF RESET

Any Reset will force all ports to Input mode and the CCP registers to their Reset states.

## 8.3.7 SETUP FOR PWM OPERATION

The following steps should be taken when configuring the CCP module for PWM operation:

1. Disable the PWM pin (CCP1) output drivers by setting the associated TRIS bit.
2. Set the PWM period by loading the PR2 register.
3. Configure the CCP module for the PWM mode by loading the CCP1CON register with the appropriate values.
4. Set the PWM duty cycle by loading the CCPR1L register and DC1B bits of the CCP1CON register.
5. Configure and start Timer2:
  - Clear the TMR2IF interrupt flag bit of the PIR1 register.
  - Set the Timer2 prescale value by loading the T2CKPS bits of the T2CON register.
  - Enable Timer2 by setting the TMR2ON bit of the T2CON register.
6. Enable PWM output after a new PWM cycle has started:
  - Wait until Timer2 overflows (TMR2IF bit of the PIR1 register is set).
  - Enable the CCP1 pin output driver by clearing the associated TRIS bit.

# PIC16F716

## 8.3.8 ENHANCED PWM AUTO-SHUTDOWN MODE

The PWM mode supports an Auto-Shutdown mode that will disable the PWM outputs when an external shutdown event occurs. Auto-Shutdown mode places the PWM output pins into a predetermined state. This mode is used to help prevent the PWM from damaging the application.

The auto-shutdown sources are selected using the ECCPASx bits of the ECCPAS register. A shutdown event may be generated by:

- A logic '0' on the INT pin
- Setting the ECCPASE bit in firmware

A shutdown condition is indicated by the ECCPASE (Auto-Shutdown Event Status) bit of the ECCPAS register. If the bit is a '0', the PWM pins are operating normally. If the bit is a '1', the PWM outputs are in the shutdown state. Refer to Figure 8-5.

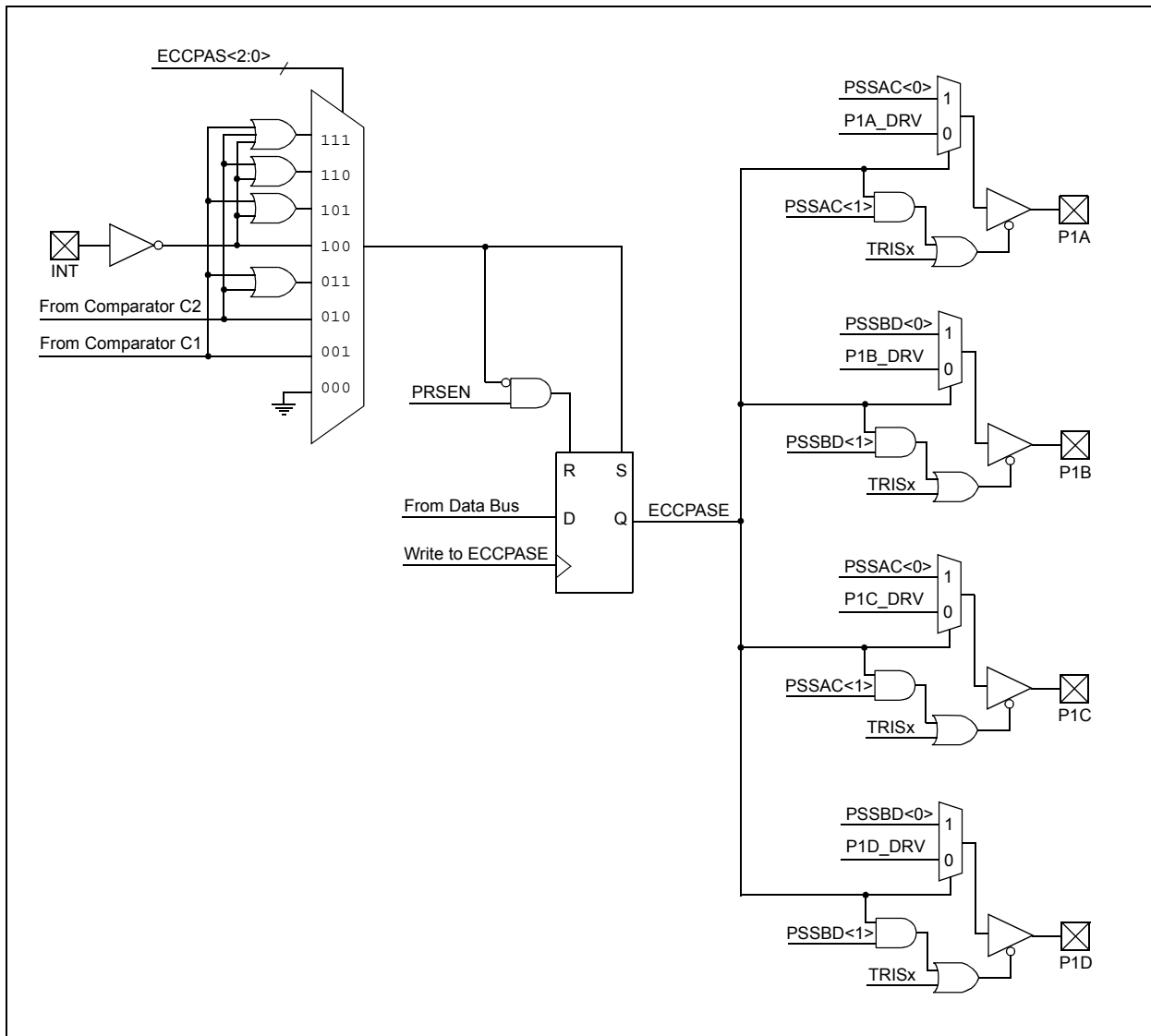
When a shutdown event occurs, two things happen:

The ECCPASE bit is set to '1'. The ECCPASE will remain set until cleared in firmware or an auto-restart occurs (see **Section 8.3.9 "Auto-Restart Mode"**).

The enabled PWM pins are asynchronously placed in their shutdown states. The PWM output pins are grouped into pairs [P1A/P1C] and [P1B/P1D]. The state of each pin pair is determined by the PSSAC and PSSBD bits of the ECCPAS register. Each pin pair may be placed into one of three states:

- Drive logic '1'
- Drive logic '0'
- Tri-state (high-impedance)

**FIGURE 8-5: AUTO-SHUTDOWN BLOCK DIAGRAM**



## REGISTER 8-2: ECCPAS: ENHANCED CAPTURE/COMPARE/PWM AUTO-SHUTDOWN CONTROL REGISTER

R/W-0	R/W-0	U-0	R/W-0	R/W-0	R/W-0	R/W-0	R/W-0
ECCPASE	ECCPAS2	—	ECCPAS0	PSSAC1	PSSAC0	PSSBD1	PSSBD0
bit 7							bit 0

### Legend:

R = Readable bit	W = Writable bit	U = Unimplemented bit, read as '0'
-n = Value at POR	'1' = Bit is set	'0' = Bit is cleared
		x = Bit is unknown

- bit 7      **ECCPASE:** ECCP Auto-Shutdown Event Status bit  
 1 = A shutdown event has occurred; ECCP outputs are in shutdown state  
 0 = ECCP outputs are operating
- bit 6      **ECCPAS2:** ECCP Auto-Shutdown bit 2  
 1 = RB0 (INT) pin low level ('0') causes shutdown  
 0 = RB0 (INT) pin has no effect on ECCP
- bit 5      **Unimplemented:** Read as '0'
- bit 4      **ECCPAS0:** ECCP Auto-Shutdown bit '0'  
 1 = RB4 pin low level ('0') causes shutdown  
 0 = RB4 pin has no effect on ECCP
- bit 3-2    **PSSACn:** Pins P1A and P1C Shutdown State Control bits  
 00 = Drive pins P1A and P1C to '0'  
 01 = Drive pins P1A and P1C to '1'  
 1x = Pins P1A and P1C tri-state
- bit 1-0    **PSSBDn:** Pins P1B and P1D Shutdown State Control bits  
 00 = Drive pins P1B and P1D to '0'  
 01 = Drive pins P1B and P1D to '1'  
 1x = Pins P1B and P1D tri-state

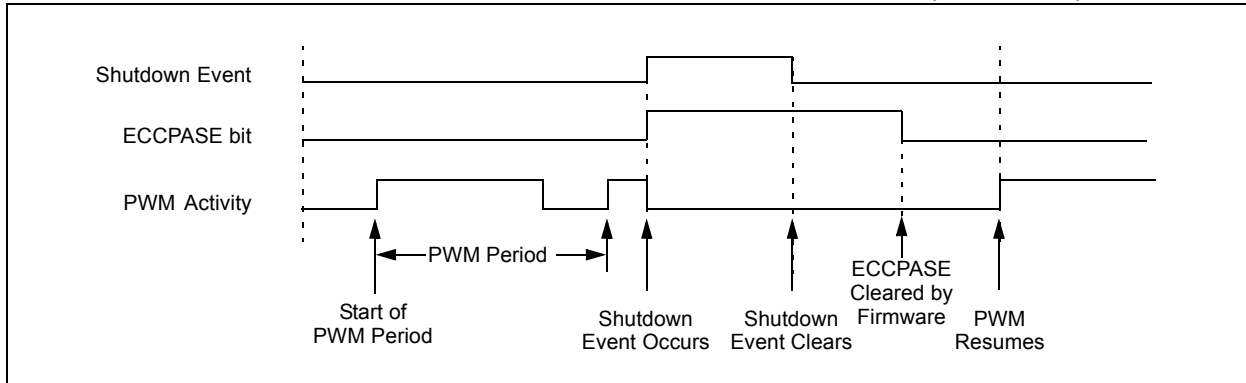
**Note 1:** The auto-shutdown condition is a level-based signal, not an edge-based signal. As long as the level is present, the auto-shutdown will persist.

**2:** Writing to the ECCPASE bit is disabled while an auto-shutdown condition persists.

**3:** Once the auto-shutdown condition has been removed and the PWM restarted (either through firmware or auto-restart), the PWM signal will always restart at the beginning of the next PWM period.

# PIC16F716

**FIGURE 8-6: PWM AUTO-SHUTDOWN WITH FIRMWARE RESTART (PRSEN = 0)**

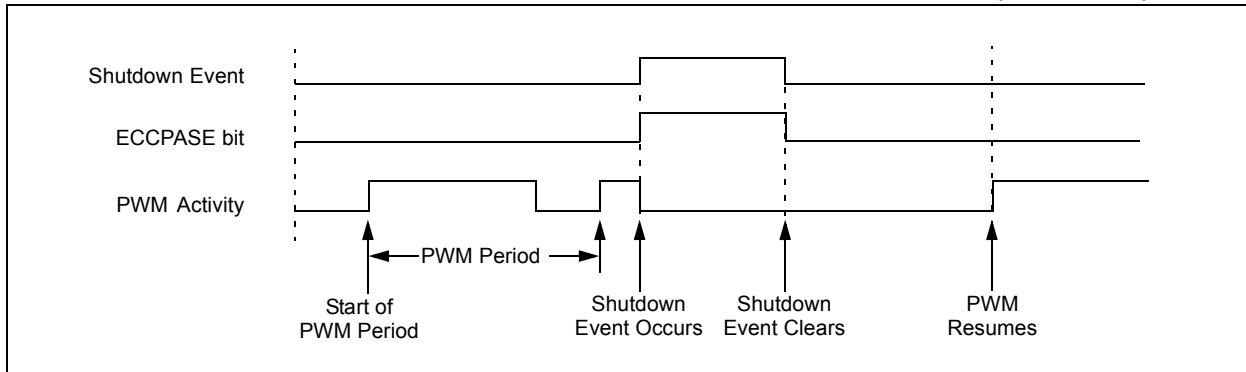


## 8.3.9 AUTO-RESTART MODE

The Enhanced PWM can be configured to automatically restart the PWM signal once the auto-shutdown condition has been removed. Auto-restart is enabled by setting the PRSEN bit in the PWM1CON register.

If auto-restart is enabled, the ECCPASE bit will remain set as long as the auto-shutdown condition is active. When the auto-shutdown condition is removed, the ECCPASE bit will be cleared via hardware and normal operation will resume.

**FIGURE 8-7: PWM AUTO-SHUTDOWN WITH AUTO-RESTART ENABLED (PRSEN = 1)**

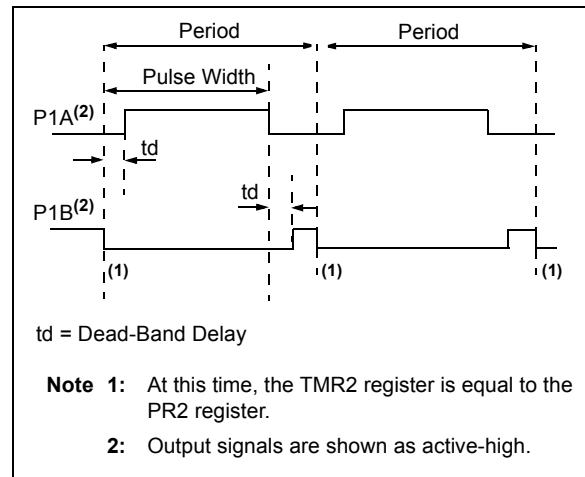


## 8.3.10 PROGRAMMABLE DEAD-BAND DELAY MODE

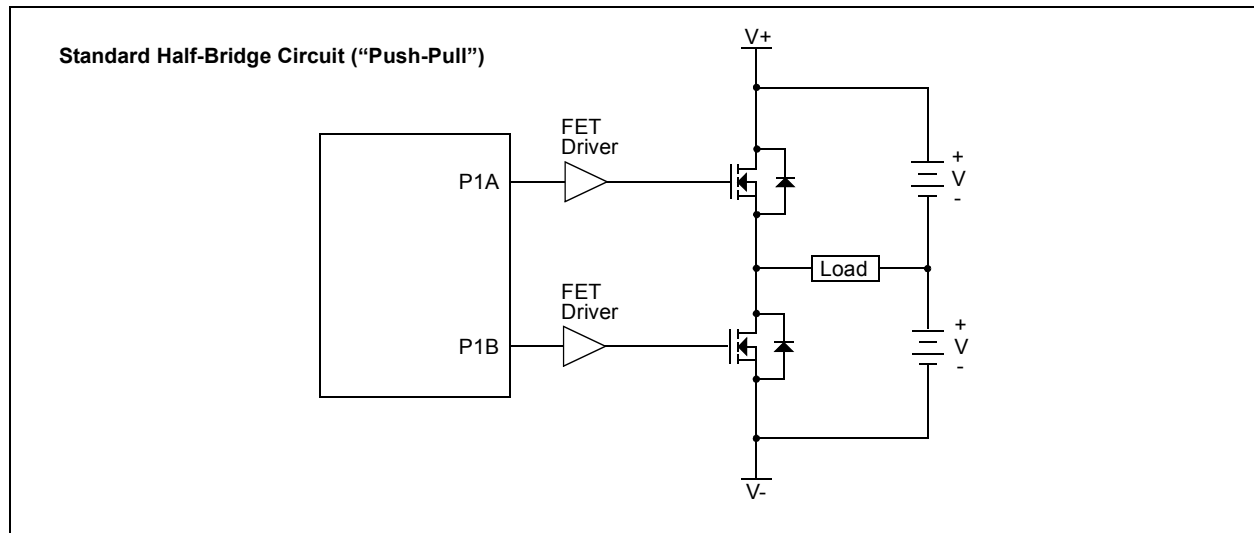
In Half-Bridge applications where all power switches are modulated at the PWM frequency, the power switches normally require more time to turn off than to turn on. If both the upper and lower power switches are switched at the same time (one turned on, and the other turned off), both switches may be on for a short period of time until one switch completely turns off. During this brief interval, a very high current (shoot-through current) will flow through both power switches, shorting the bridge supply. To avoid this potentially destructive shoot-through current from flowing during switching, turning on either of the power switches is normally delayed to allow the other switch to completely turn off.

In Half-Bridge mode, a digitally programmable dead-band delay is available to avoid shoot-through current from destroying the bridge power switches. The delay occurs at the signal transition from the non-active state to the active state. See Figure 8-8 for illustration. The lower seven bits of the associated PWM1CON register (Register 8-3) sets the delay period in terms of microcontroller instruction cycles ( $T_{CY}$  or  $4 T_{OSC}$ ).

**FIGURE 8-8: EXAMPLE OF HALF-BRIDGE PWM OUTPUT**



**FIGURE 8-9: EXAMPLE OF HALF-BRIDGE APPLICATIONS**



# PIC16F716

## REGISTER 8-3: PWM1CON: ENHANCED PWM CONTROL REGISTER

R/W-0	R/W-0	R/W-0	R/W-0	R/W-0	R/W-0	R/W-0	R/W-0
PRSEN	PDC6	PDC5	PDC4	PDC3	PDC2	PDC1	PDC0
bit 7							bit 0

### Legend:

R = Readable bit                      W = Writable bit                      U = Unimplemented bit, read as '0'  
 -n = Value at POR                      '1' = Bit is set                      '0' = Bit is cleared                      x = Bit is unknown

bit 7                      **PRSEN:** PWM Restart Enable bit  
                             1 = Upon auto-shutdown, the ECCPASE bit clears automatically once the shutdown event goes away; the PWM restarts automatically  
                             0 = Upon auto-shutdown, ECCPASE must be cleared in software to restart the PWM

bit 6-0                      **PDC<6:0>:** PWM Delay Count bits  
                             PDCn = Number of Fosc/4 (4 \* Tosc) cycles between the scheduled time when a PWM signal **should** transition active and the **actual** time it transitions active

## TABLE 8-6: REGISTERS ASSOCIATED WITH PWM

Name	Bit 7	Bit 6	Bit 5	Bit 4	Bit 3	Bit 2	Bit 1	Bit 0	Value on POR, BOR	Value on all other Resets
CCPR1L	Capture/Compare/PWM Register 1 (LSB)								xxxx xxxx	xxxx xxxx
CCPR1H	Capture/Compare/PWM Register 1 (MSB)								xxxx xxxx	xxxx xxxx
CCP1CON	P1M1	P1M0	DC1B1	DC1B0	CCP1M3	CCP1M2	CCP1M1	CCP1M0	0000 0000	0000 0000
ECCPAS	ECCPASE	ECCPAS2	—	ECCPAS0	PSSAC1	PSSAC0	PSSBD1	PSSBD0	00-0 0000	00-0 0000
INTCON	GIE	PEIE	T0IE	INTE	RBIE	T0IF	INTF	RBIF	0000 000x	0000 000x
PIE1	—	ADIE	—	—	—	CCP1IE	TMR2IE	TMR1IE	-0-- -000	-0-- -000
PIR1	—	ADIF	—	—	—	CCP1IF	TMR2IF	TMR1IF	-0-- 0000	-0-- -000
PR2	Timer2 Period Register								1111 1111	1111 1111
PWM1CON	PRSEN	PDC6	PDC5	PDC4	PDC3	PDC2	PDC1	PDC0	0000 0000	0000 0000
TMR1L	Holding Register for the Least Significant Byte of the 16-bit TMR1 Register								xxxx xxxx	xxxx xxxx
TMR1H	Holding Register for the Most Significant Byte of the 16-bit TMR1 Register								xxxx xxxx	xxxx xxxx
TMR2	Timer2 Module's Register								0000 0000	0000 0000
TRISB	TRISB7	TRISB6	TRISB5	TRISB4	TRISB3	TRISB2	TRISB1	TRISB0	1111 1111	1111 1111

**Legend:** — = Unimplemented locations, read as '0', u = unchanged, x = unknown. Shaded cells are not used by the PWM.

## 9.0 SPECIAL FEATURES OF THE CPU

The PIC16F716 device has a host of features intended to maximize system reliability, minimize cost through elimination of external components, provide power-saving operating modes and offer code protection. These are:

- OSC Selection
- Reset
  - Power-on Reset (POR)
  - Power-up Timer (PWRT)
  - Oscillator Start-up Timer (OST)
  - Brown-out Reset (BOR)
- Interrupts
- Watchdog Timer (WDT)
- Sleep
- Code protection
- ID locations
- In-Circuit Serial Programming™ (ICSP™)

The PIC16F716 device has a Watchdog Timer, which can be shut off only through Configuration bits. It runs off its own RC oscillator for added reliability. There are two timers that offer necessary delays on power-up. One is the Oscillator Start-up Timer (OST), intended to keep the chip in Reset until the crystal oscillator is stable. The other is the Power-up Timer (PWRT), which provides a fixed delay on power-up only and is designed to keep the part in Reset while the power supply stabilizes. With these two timers on-chip, most applications need no external Reset circuitry.

Sleep mode is designed to offer a very low-current Power-Down mode. The user can wake-up from Sleep through external Reset, Watchdog Timer Wake-up, or through an interrupt. Several oscillator options are also made available to allow the part to fit the application. The RC oscillator option saves system cost, while the LP crystal option saves power. A set of Configuration bits are used to select various options.

## 9.1 Configuration Bits

The Configuration bits can be programmed (read as '0') or left unprogrammed (read as '1') to select various device configurations. These bits are mapped in program memory location 2007h.

The user will note that address 2007h is beyond the user program memory space. In fact, it belongs to the special configuration memory space (2000h-3FFFh), which can be accessed only during programming.

# PIC16F716

## REGISTER 9-1: CONFIG: CONFIGURATION WORD REGISTER

—	—	$\overline{CP}^{(2)}$	—	—	—	—	—
bit 15							bit 8

BORV	BOREN <sup>(1)</sup>	—	—	$\overline{PWRT\bar{E}}$	WDTE	FOSC1	FOSC0
bit 7							bit 0

### Legend:

R = Readable bit	W = Writable bit	P = Programmable'	U = Unimplemented bit, read as '0'
-n = Value at POR	'1' = Bit is set	'0' = Bit is cleared	x = Bit is unknown

- bit 15-14     **Unimplemented:** Read as '1'
- bit 13        **$\overline{CP}$ :** Code Protection bit<sup>(2)</sup>
  - 1 = Program memory code protection is disabled
  - 0 = Program memory code protection is enabled
- bit 12-8     **Unimplemented:** Read as '1'
- bit 7        **BORV:** Brown-out Reset Voltage bit
  - 1 = VBOR set to 4.0V
  - 0 = VBOR set to 2.5V
- bit 6        **BOREN:** Brown-out Reset Selection bits<sup>(1)</sup>
  - 1 = BOR enabled
  - 0 = BOR disabled
- bit 5-4     **Unimplemented:** Read as '1'
- bit 3         **$\overline{PWRT\bar{E}}$ :** Power-up Timer Enable bit<sup>(1)</sup>
  - 1 = PWRT disabled
  - 0 = PWRT enabled
- bit 2        **WDTE:** Watchdog Timer Enable bit
  - 1 = WDT enabled
  - 0 = WDT disabled
- bit 1-0     **FOSC<2:0>:** Oscillator Selection bits
  - 11 = RC oscillator
  - 10 = HS oscillator
  - 01 = XT oscillator
  - 00 = LP oscillator

- Note 1:** Enabling Brown-out Reset does not automatically enable Power-up Timer.  
**Note 2:** The entire program memory will be erased when the code protection is turned off.

## 9.2 Oscillator Configurations

### 9.2.1 OSCILLATOR TYPES

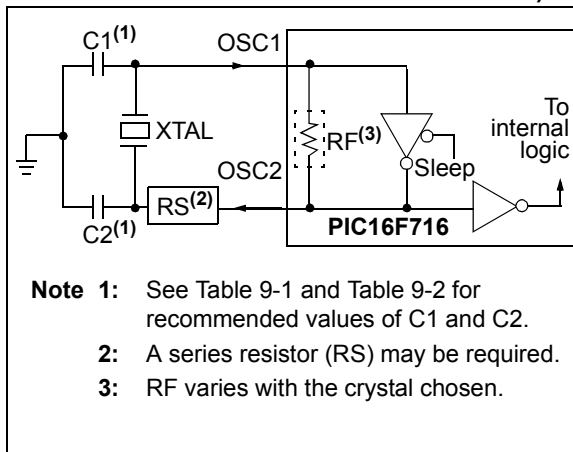
The PIC16F716 can be operated in four different oscillator modes. The user can program two Configuration bits (FOSC1 and FOSC0) to select one of these four modes:

- LP – Low-power Crystal
- XT – Crystal/Resonator
- HS – High-speed Crystal/Resonator
- RC – Resistor/Capacitor

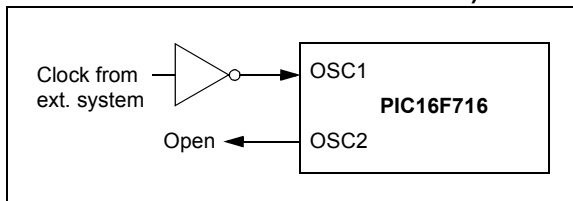
### 9.2.2 CRYSTAL OSCILLATOR/CERAMIC RESONATORS

In XT, LP or HS modes, a crystal or ceramic resonator is connected to the OSC1/CLKIN and OSC2/CLKOUT pins to establish oscillation (Figure 9-1). The PIC16F716 oscillator design requires the use of a parallel cut crystal. Use of a series cut crystal may give a frequency out of the crystal manufacturers specifications. When in XT, LP or HS modes, the device can have an external clock source to drive the OSC1/CLKIN pin (Figure 9-2).

**FIGURE 9-1: CRYSTAL/CERAMIC RESONATOR OPERATION (HS, XT OR LP OSC CONFIGURATION)**



**FIGURE 9-2: EXTERNAL CLOCK INPUT OPERATION (HS, XT OR LP OSC CONFIGURATION)**



**TABLE 9-1: CERAMIC RESONATORS**

Ranges Tested:			
Mode	Freq	OSC1 (C1)	OSC2 (C2)
XT	455 kHz	68-100 pF	68-100 pF
	2.0 MHz	15-68 pF	15-68 pF
HS	4.0 MHz	10-68 pF	10-68 pF
	8.0 MHz	15-68 pF	15-68 pF
	16.0 MHz	10-22 pF	10-22 pF

**Note 1:** These values are for design guidance only. See notes at bottom of page.

**TABLE 9-2: CAPACITOR SELECTION FOR CRYSTAL OSCILLATOR**

Osc Type	Crystal Freq	Cap. Range C1	Cap. Range C2
LP	32 kHz	15-33 pF	15-33 pF
	200 kHz	5-10 pF	5-10 pF
XT	200 kHz	47-68 pF	47-68 pF
	1 MHz	15-33 pF	15-33 pF
	4 MHz	15-33 pF	15-33 pF
HS	4 MHz	15-33 pF	15-33 pF
	8 MHz	15-33 pF	15-33 pF
	20 MHz	15-33 pF	15-33 pF

**Note 1:** These values are for design guidance only. See notes at bottom of page.

**Note 1:** Higher capacitance increases the stability of the oscillator, but also increases the start-up time.

**2:** Since each resonator/crystal has its own characteristics, the user should consult the resonator/crystal manufacturer for appropriate values of external components.

**3:** RS may be required to avoid overdriving crystals with low drive level specification.

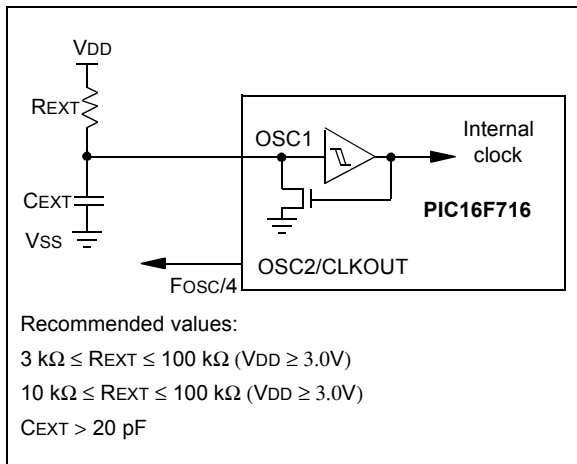
**4:** When using an external clock for the OSC1 input, loading of the OSC2 pin must be kept to a minimum by leaving the OSC2 pin unconnected.

# PIC16F716

## 9.2.3 RC OSCILLATOR

For timing insensitive applications, the “RC” device option offers additional cost savings. The RC oscillator frequency is a function of the supply voltage, the resistor ( $R_{EXT}$ ) and capacitor ( $C_{EXT}$ ) values and the operating temperature. In addition to this, the oscillator frequency will vary from unit-to-unit due to normal process parameter variation. Furthermore, the difference in lead frame capacitance between package types will also affect the oscillation frequency, especially for low  $C_{EXT}$  values. The user also needs to take into account variation due to tolerance of external R and C components used. Figure 9-3 shows how the R/C combination is connected to the PIC16F716.

**FIGURE 9-3: RC OSCILLATOR MODE**



## 9.3 Reset

The PIC16F716 differentiates between various kinds of Reset:

- Power-on Reset (POR)
- $\overline{\text{MCLR}}$  Reset during normal operation
- $\overline{\text{MCLR}}$  Reset during Sleep
- WDT Reset (during normal operation)
- WDT Wake-up (during Sleep)
- Brown-out Reset (BOR)

Some registers are not affected in any Reset condition; their status is unknown on POR and unchanged in any other Reset. Most other registers are reset to a “Reset state” on Power-on Reset (POR), on the  $\overline{\text{MCLR}}$  and WDT Reset, on  $\overline{\text{MCLR}}$  Reset during Sleep and Brown-out Reset (BOR). They are not affected by a WDT Wake-up, which is viewed as the resumption of normal operation. The  $\overline{\text{TO}}$  and  $\overline{\text{PD}}$  bits are set or cleared differently in different Reset situations as indicated in Table 9-4. These bits are used in software to determine the nature of the Reset. See Table 9-6 for a full description of Reset states of all registers.

A simplified block diagram of the On-chip Reset circuit is shown in Figure 9-5.

The PIC<sup>®</sup> microcontrollers have an  $\overline{\text{MCLR}}$  noise filter in the  $\overline{\text{MCLR}}$  Reset path. The filter will detect and ignore small pulses.

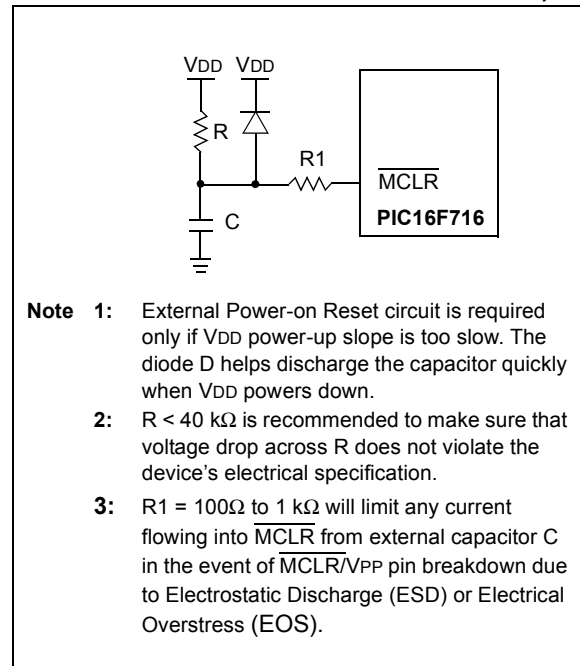
It should be noted that a WDT Reset does not drive the  $\overline{\text{MCLR}}$  pin low.

## 9.4 Power-On Reset (POR)

A Power-on Reset pulse is generated on-chip when  $V_{DD}$  rise is detected. To take advantage of the POR, just tie the  $\overline{\text{MCLR}}$  pin directly (or through a resistor) to  $V_{DD}$ . This will eliminate external RC components usually needed to create a Power-on Reset. A maximum rise time for  $V_{DD}$  is specified (parameter D004). For a slow rise time, see Figure 9-4.

When the device starts normal operation (exits the Reset condition), device operating parameters (voltage, frequency, temperature,...) must be met to ensure operation. If these conditions are not met, the device must be held in Reset until the operating conditions are met. Brown-out Reset may be used to meet the start-up conditions.

**FIGURE 9-4: EXTERNAL POWER-ON RESET CIRCUIT (FOR SLOW  $V_{DD}$  POWER-UP)**



## 9.5 Power-up Timer (PWRT)

The Power-up Timer provides a fixed nominal time-out, on power-up only, from the POR. The Power-up Timer operates on an internal RC oscillator. The chip is kept in Reset as long as the PWRT is active. The PWRT's time delay allows  $V_{DD}$  to rise to an acceptable level. The power-up timer enable Configuration bit,  $\overline{PWRTE}$ , is provided to enable/disable the PWRT.

The power-up time delay will vary from chip-to-chip due to  $V_{DD}$ , temperature and process variation. See AC parameters for details.

## 9.6 Oscillator Start-up Timer (OST)

The Oscillator Start-up Timer (OST) provides a 1024 oscillator cycle (from OSC1 input) delay after the PWRT delay is over. This ensures that the crystal oscillator or resonator has started and stabilized. See AC parameters for details.

The OST time-out is invoked only for XT, LP and HS modes and only on Power-on Reset or wake-up from Sleep.

## 9.7 Programmable Brown-Out Reset (PBOR)

The PIC16F716 has on-chip Brown-out Reset circuitry. A Configuration bit, BOREN, can disable (if clear/programmed) or enable (if set) the Brown-out Reset circuitry.

The BORV Configuration bit selects the programmable Brown-out Reset threshold voltage ( $V_{BOR}$ ). When BORV is 1,  $V_{BOR}$  is 4.0V. When BORV is 0,  $V_{BOR}$  is 2.5V.

A Brown-out Reset occurs when  $V_{DD}$  falls below  $V_{BOR}$  for a time greater than parameter  $T_{BOR}$  (see Table 12-4). A Brown-out Reset is not guaranteed to occur if  $V_{DD}$  falls below  $V_{BOR}$  for less than parameter  $T_{BOR}$ .

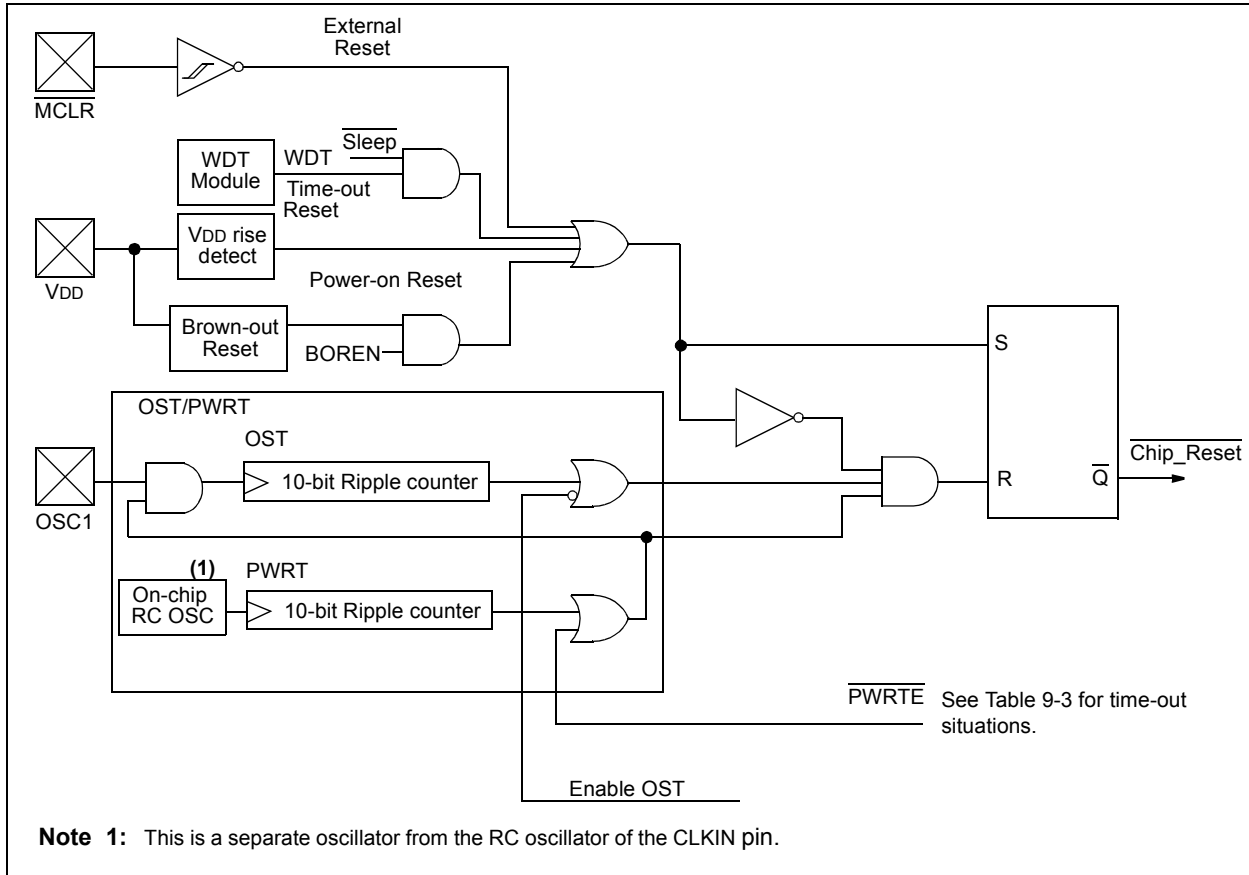
On any Reset (Power-on, Brown-out, Watchdog, etc.) the chip will remain in Reset until  $V_{DD}$  rises above  $V_{BOR}$ . The Power-up Timer will be invoked and will keep the chip in Reset an additional 72 ms only if the Power-up Timer enable bit in the Configuration register is set to 0 ( $\overline{PWRTE} = 0$ ).

If the Power-up Timer is enabled and  $V_{DD}$  drops below  $V_{BOR}$  while the Power-up Timer is running, the chip will go back into a Brown-out Reset and the Power-up Timer will be re-initialized. Once  $V_{DD}$  rises above  $V_{BOR}$ , the Power-up Timer will execute a 72 ms Reset. See Figure 9-6.

For operations where the desired brown-out voltage is other than 4.0V or 2.5V, an external brown-out circuit must be used. Figure 9-8, Figure 9-9 and Figure 9-10 show examples of external Brown-out Protection circuits.

# PIC16F716

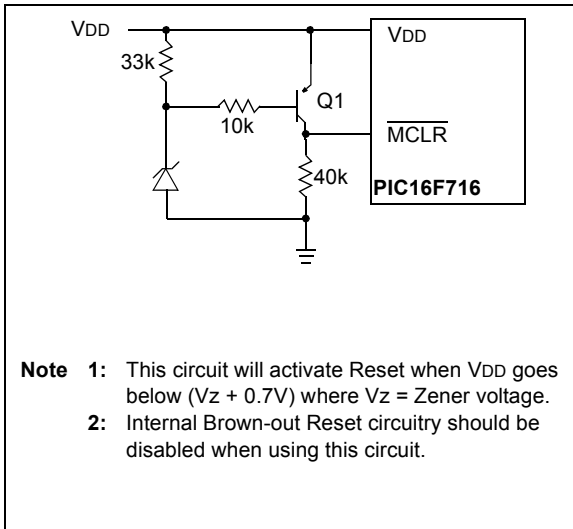
**FIGURE 9-5: SIMPLIFIED BLOCK DIAGRAM OF ON-CHIP RESET CIRCUIT**



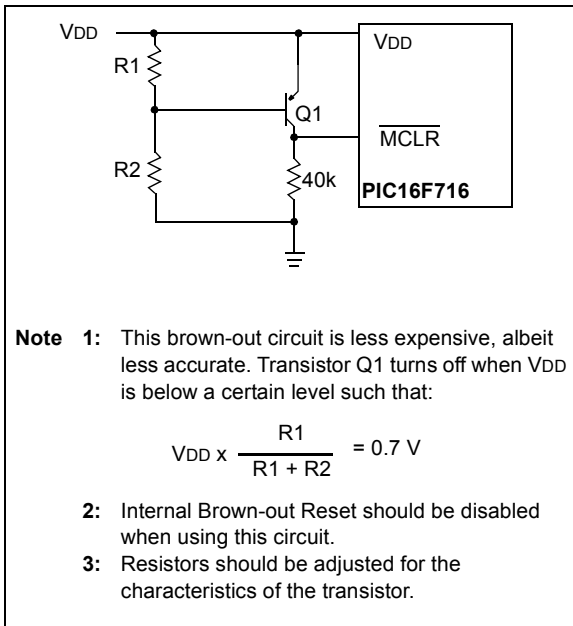
**FIGURE 9-6: BROWN-OUT SITUATIONS ( $\overline{\text{PWRT}} = 0$ )**



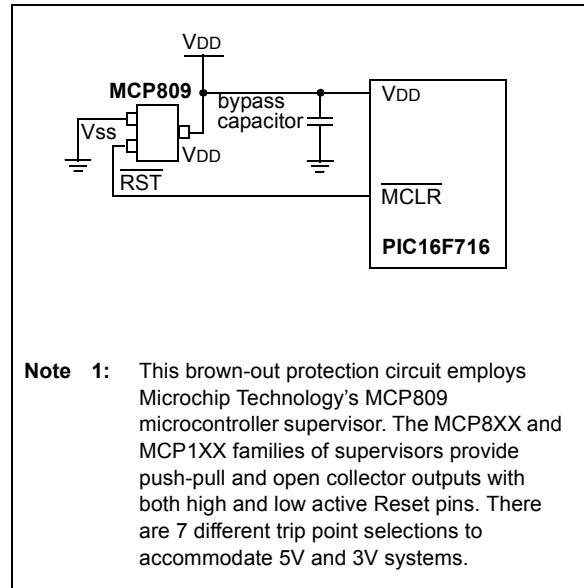
**FIGURE 9-7: EXTERNAL BROWN-OUT PROTECTION CIRCUIT 1**



**FIGURE 9-8: EXTERNAL BROWN-OUT PROTECTION CIRCUIT 2**



**FIGURE 9-9: EXTERNAL BROWN-OUT PROTECTION CIRCUIT 3**



# PIC16F716

## 9.8 Time-out Sequence

On power-up, the time-out sequence is as follows: First PWRT time-out is invoked after the POR time delay has expired. Then OST is activated. The total time-out will vary based on oscillator configuration and the status of the PWRT. For example, in RC mode with the PWRT disabled, there will be no time-out at all. Figure 9-10, Figure 9-11, and Figure 9-12 depict time-out sequences on power-up.

Since the time-outs occur from the POR pulse, if  $\overline{\text{MCLR}}$  is kept low long enough, the time-outs will expire. Then bringing  $\overline{\text{MCLR}}$  high will begin execution immediately (Figure 9-12). This is useful for testing purposes or to synchronize more than one PIC16F716 device operating in parallel.

Table 9-5 shows the Reset conditions for some Special Function Registers, while Table 9-6 shows the Reset conditions for all the registers.

**TABLE 9-3: TIME-OUT IN VARIOUS SITUATIONS**

Oscillator Configuration	Power-up or Brown-out		Wake-up from Sleep
	$\overline{\text{PWRT}} = 0$	$\overline{\text{PWRT}} = 1$	
XT, HS, LP	72 ms + 1024 Tosc	1024 Tosc	1024 Tosc
RC	72 ms	—	—

**TABLE 9-4: STATUS BITS AND THEIR SIGNIFICANCE**

POR	BOR	$\overline{\text{TO}}$	$\overline{\text{PD}}$	
0	x	1	1	Power-on Reset (BOREN = 0)
0	1	1	1	Power-on Reset (BOREN = 1)
0	x	0	x	Illegal, $\overline{\text{TO}}$ is set on $\overline{\text{POR}}$
0	x	x	0	Illegal, $\overline{\text{PD}}$ is set on $\overline{\text{POR}}$
1	0	1	1	Brown-out Reset
1	1	0	1	WDT Reset
1	1	0	0	WDT Wake-up
1	1	u	u	$\overline{\text{MCLR}}$ Reset during normal operation
1	1	1	0	$\overline{\text{MCLR}}$ Reset during Sleep or interrupt wake-up from Sleep

## 9.9 Power Control/STATUS Register (PCON)

The Power Control/STATUS Register, PCON has two bits.

Bit 0 is the Brown-out Reset Status bit,  $\overline{\text{BOR}}$ . If the BOREN Configuration bit is set,  $\overline{\text{BOR}}$  is '1' on Power-on Reset and reset to '0' when a Brown-out condition occurs. BOR must then be set by the user and checked on subsequent resets to see if it is clear, indicating that another Brown-out has occurred.

If the BOREN Configuration bit is clear,  $\overline{\text{BOR}}$  is unknown on Power-on Reset.

Bit 1 is  $\overline{\text{POR}}$  (Power-on Reset Status bit). It is cleared on a Power-on Reset and unaffected otherwise. The user must set this bit following a Power-on Reset.

**TABLE 9-5: RESET CONDITION FOR SPECIAL REGISTERS**

Condition	Program Counter	STATUS Register	PCON Register
Power-on Reset (BOREN = 0)	000h	0001 1xxx	---- --0x
Power-on Reset (BOREN = 1)	000h	0001 1xxx	---- --01
MCLR Reset during normal operation	000h	000u uuuu	---- --uu
MCLR Reset during Sleep	000h	0001 0uuu	---- --uu
WDT Reset	000h	0000 1uuu	---- --uu
WDT Wake-up	PC + 1	uuu0 0uuu	---- --uu
Brown-out Reset	000h	0001 1uuu	---- --u0
Interrupt wake-up from Sleep	PC + 1 <sup>(1)</sup>	uuu1 0uuu	---- --uu

**Legend:** u = unchanged, x = unknown, - = unimplemented bit read as '0'.

**Note 1:** When the wake-up is due to an interrupt and the GIE bit is set, the PC is loaded with the interrupt vector (0004h).

# PIC16F716

**TABLE 9-6: INITIALIZATION CONDITIONS FOR ALL REGISTERS OF THE PIC16F716**

Register	Power-on Reset, Brown-out Reset	MCLR Resets WDT Reset	Wake-up via WDT or Interrupt
W	xxxx xxxx	uuuu uuuu	uuuu uuuu
INDF	N/A	N/A	N/A
TMR0	xxxx xxxx	uuuu uuuu	uuuu uuuu
PCL	0000h	0000h	PC + 1 <sup>(2)</sup>
STATUS	0001 1xxx	000q quuu <sup>(3)</sup>	uuuq quuu <sup>(3)</sup>
FSR	xxxx xxxx	uuuu uuuu	uuuu uuuu
PORTA <sup>(4), (5), (6)</sup>	--xx 0000	--xx 0000	--uu uuuu
PORTB <sup>(4), (5)</sup>	xxxx xxxx	uuuu uuuu	uuuu uuuu
PCLATH	---0 0000	---0 0000	---u uuuu
INTCON	0000 -00x	0000 -00u	uuuu -uuu <sup>(1)</sup>
PIR1	-0-- -000	-0-- -000	-u-- -uuu <sup>(1)</sup>
TMR1L	xxxx xxxx	uuuu uuuu	uuuu uuuu
TMR1H	xxxx xxxx	uuuu uuuu	uuuu uuuu
T1CON	--00 0000	--uu uuuu	--uu uuuu
TMR2	0000 0000	0000 0000	uuuu uuuu
T2CON	-000 0000	-000 0000	-uuu uuuu
CCPR1L	xxxx xxxx	uuuu uuuu	uuuu uuuu
CCPR1H	xxxx xxxx	uuuu uuuu	uuuu uuuu
CCP1CON	0000 0000	0000 0000	uuuu uuuu
PWM1CON	0000 0000	0000 0000	uuuu uuuu
ECCPAS	00-0 0000	00-0 0000	u-uu uuuu
ADRES	xxxx xxxx	uuuu uuuu	uuuu uuuu
ADCON0	0000 0000	0000 0000	uuuu uuuu
OPTION_REG	1111 1111	1111 1111	uuuu uuuu
TRISA	--11 1111	--11 1111	--uu uuuu
TRISB	1111 1111	1111 1111	uuuu uuuu
PIE1	-0-- -000	-0-- -000	-u-- -uuu
PCON	---- -qqq	---- -uuu	---- -uuu
PR2	1111 1111	1111 1111	uuuu uuuu
ADCON1	---- -000	---- -000	---- -uuu

**Legend:** u = unchanged, x = unknown, - = unimplemented bit, read as '0', q = value depends on condition

**Note 1:** One or more bits in INTCON and/or PIR1 will be affected (to cause wake-up).

**2:** When the wake-up is due to an interrupt and the GIE bit is set, the PC is loaded with the interrupt vector (0004h).

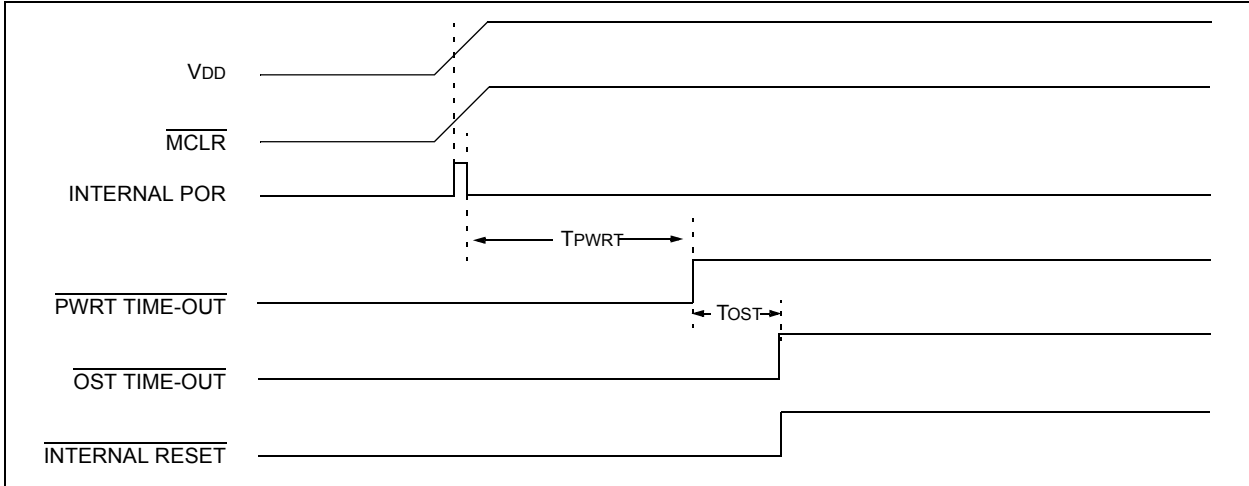
**3:** See Table 9-5 for Reset value for specific condition.

**4:** On any device Reset, these pins are configured as inputs.

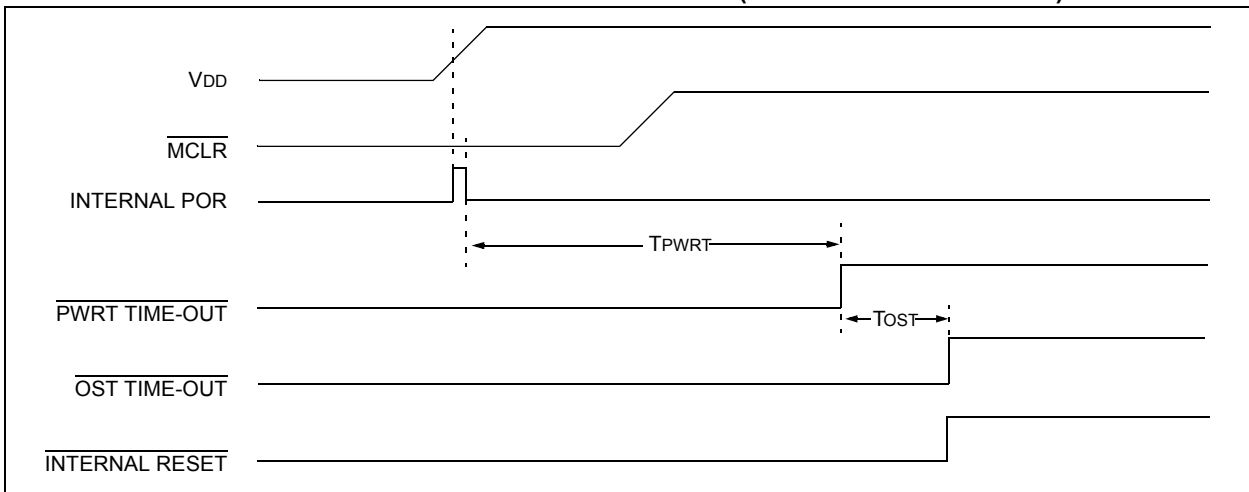
**5:** This is the value that will be in the port output latch.

**6:** Output latches are unknown or unchanged. Analog inputs default to analog and read '0'.

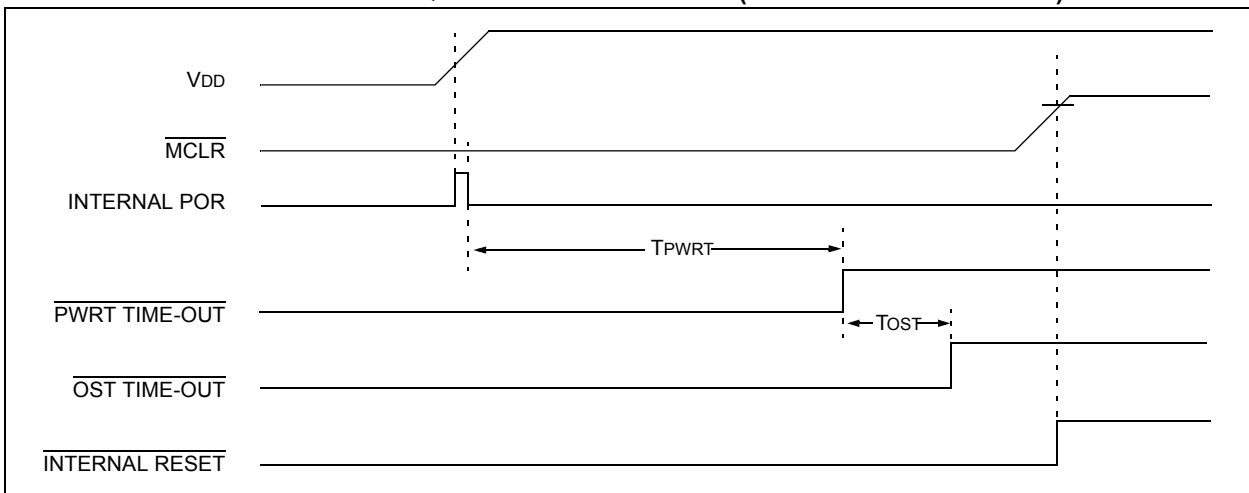
**FIGURE 9-10: TIME-OUT SEQUENCE ON POWER-UP ( $\overline{\text{MCLR}}$  TIED TO  $V_{DD}$ )**



**FIGURE 9-11: TIME-OUT SEQUENCE ON POWER-UP ( $\overline{\text{MCLR}}$  NOT TIED TO  $V_{DD}$ ): CASE 1**



**FIGURE 9-12: TIME-OUT SEQUENCE ON POWER-UP ( $\overline{\text{MCLR}}$  NOT TIED TO  $V_{DD}$ ): CASE 2**



# PIC16F716

## 9.10 Interrupts

The PIC16F716 devices have up to 7 sources of interrupt. The Interrupt Control Register (INTCON) records individual interrupt requests in flag bits. It also has individual and global interrupt enable bits.

**Note:** Individual interrupt flag bits are set regardless of the status of their corresponding mask bit or the GIE bit.

A Global Interrupt Enable bit, GIE of the INTCON register enables all un-masked interrupts when set, or disables all interrupts when cleared. When bit GIE is enabled, and an interrupt's flag bit and mask bit are set, the interrupt will vector immediately. Individual interrupts can be disabled through their corresponding enable bits in various registers. Individual interrupt bits are set, regardless of the status of the GIE bit. The GIE bit is cleared on Reset and when an interrupt vector occurs.

The "return-from-interrupt" instruction, `RETFIE`, exits the interrupt routine, as well as sets the GIE bit, which re-enables interrupts.

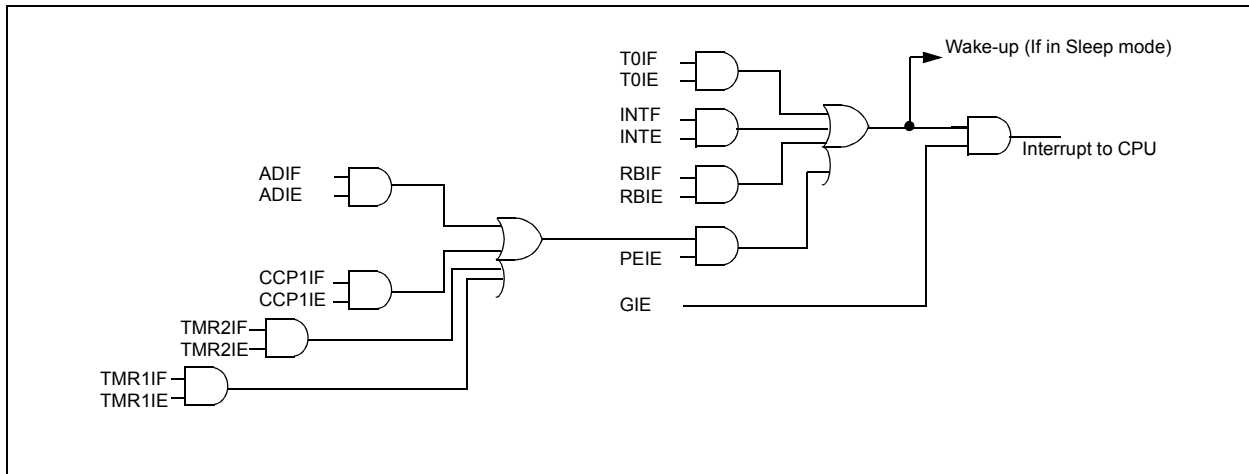
The RB0/INT pin interrupt, the RB port change interrupt and the TMR0 overflow interrupt flags are contained in the INTCON register.

The peripheral interrupt flags are contained in the Special Function Registers, PIR1 and PIR2. The corresponding interrupt enable bits are contained in Special Function Registers, PIE1 and PIE2, and the peripheral interrupt enable bit is contained in Special Function Register, INTCON.

When an interrupt is responded to, the GIE bit is cleared to disable any further interrupt, the return address is pushed onto the stack and the PC is loaded with 0004h. Once in the Interrupt Service Routine, the source(s) of the interrupt can be determined by polling the interrupt flag bits. The interrupt flag bit(s) must be cleared in software before re-enabling interrupts to avoid recursive interrupts.

For external interrupt events, such as the INT pin or PORTB change interrupt, the interrupt latency will be three or four instruction cycles. The exact latency depends when the interrupt event occurs. The latency is the same for one or two-cycle instructions. Individual interrupt flag bits are set, regardless of the status of their corresponding mask bit or the GIE bit.

**FIGURE 9-13: INTERRUPT LOGIC**



## 9.10.1 INT INTERRUPT

External interrupt on RB0/INT pin is edge triggered, either rising if bit INTEDG of the OPTION register is set, or falling if the INTEDG bit is clear. When a valid edge appears on the RB0/INT pin, flag bit INTF of the INTCON register is set. This interrupt can be disabled by clearing enable bit INTE of the INTCON register. Flag bit INTF must be cleared in software in the Interrupt Service Routine before re-enabling this interrupt. The INT interrupt can wake-up the processor from Sleep, if bit INTE was set prior to going into Sleep. The status of global interrupt enable bit GIE decides whether or not the processor branches to the interrupt vector following wake-up. See **Section 9.13 “Power-down Mode (Sleep)”** for details on Sleep mode.

## 9.10.2 TMR0 INTERRUPT

An overflow (FFh → 00h) in the TMR0 register will set flag bit T0IF of the INTCON register. The interrupt can be enabled/disabled by setting/clearing enable bit T0IE of the INTCON register. (**Section 4.0 “Timer0 Module”**).

## 9.10.3 PORTB INTCON CHANGE

An input change on PORTB<7:4> sets flag bit RBIF of the INTCON register. The interrupt can be enabled/disabled by setting/clearing enable bit RBIE of the INTCON register. (**Section 3.2 “PORTB and the TRISB Register”**).

## 9.11 Context Saving During Interrupts

During an interrupt, only the return PC value is saved on the stack. Typically, users may wish to save key registers during an interrupt, (i.e., W register and STATUS register). This will have to be implemented in firmware.

Example 9-1 stores and restores the W, STATUS, PCLATH and FSR registers. Context storage registers, W\_TEMP, STATUS\_TEMP, PCLATH\_TEMP and FSR\_TEMP, must be defined in Common RAM which are those addresses between 70h-7Fh in Bank 0 and between F0h-FFh in Bank 1.

The example:

- a) Stores the W register.
- b) Stores the STATUS register in Bank 0.
- c) Stores the PCLATH register.
- d) Stores the FSR register.
- e) Executes the Interrupt Service Routine code (User-generated).
- f) Restores all saved registers in reverse order from which they were stored.

### EXAMPLE 9-1: SAVING STATUS, W, AND PCLATH REGISTERS IN RAM

```

MOVWF    W_TEMP           ;Copy W to TEMP register, could be bank one or zero
SWAPF    STATUS,W         ;Swap status to be saved into W
MOVWF    STATUS_TEMP      ;Save status to bank zero STATUS_TEMP register
MOVF     PCLATH, W        ;Only required if using pages 1, 2 and/or 3
MOVWF    PCLATH_TEMP      ;Save PCLATH into W
CLRF     PCLATH           ;Page zero, regardless of current page
BCF      STATUS, IRP      ;Return to Bank 0
MOVF     FSR, W           ;Copy FSR to W
MOVWF    FSR_TEMP         ;Copy FSR from W to FSR_TEMP
:
: (ISR)
:
MOVF     FSR_TEMP,W       ;Restore FSR
MOVWF    FSR              ;Move W into FSR
MOVF     PCLATH_TEMP, W   ;Restore PCLATH
MOVWF    PCLATH           ;Move W into PCLATH
SWAPF    STATUS_TEMP,W    ;Swap STATUS_TEMP register into W
MOVWF    STATUS           ;Move W into STATUS register
SWAPF    W_TEMP,F         ;Swap W_TEMP
SWAPF    W_TEMP,W         ;Swap W_TEMP into W
RETFIE                          ;Return from interrupt and enable GIE

```

# PIC16F716

## 9.12 Watchdog Timer (WDT)

The Watchdog Timer is a free running, on-chip, RC oscillator which does not require any external components. This RC oscillator is separate from the RC oscillator of the OSC1/CLKIN pin. That means that the WDT will run, even if the clock on the OSC1/CLKIN and OSC2/CLKOUT pins of the device have been stopped, for example, by execution of a `SLEEP` instruction.

During normal operation, a WDT time-out generates a device Reset (Watchdog Timer Reset). If the device is in Sleep mode, a WDT time-out causes the device to wake-up and continue with normal operation (Watchdog Timer Wake-up). The  $\overline{TO}$  bit in the STATUS register will be cleared upon a Watchdog Timer time-out.

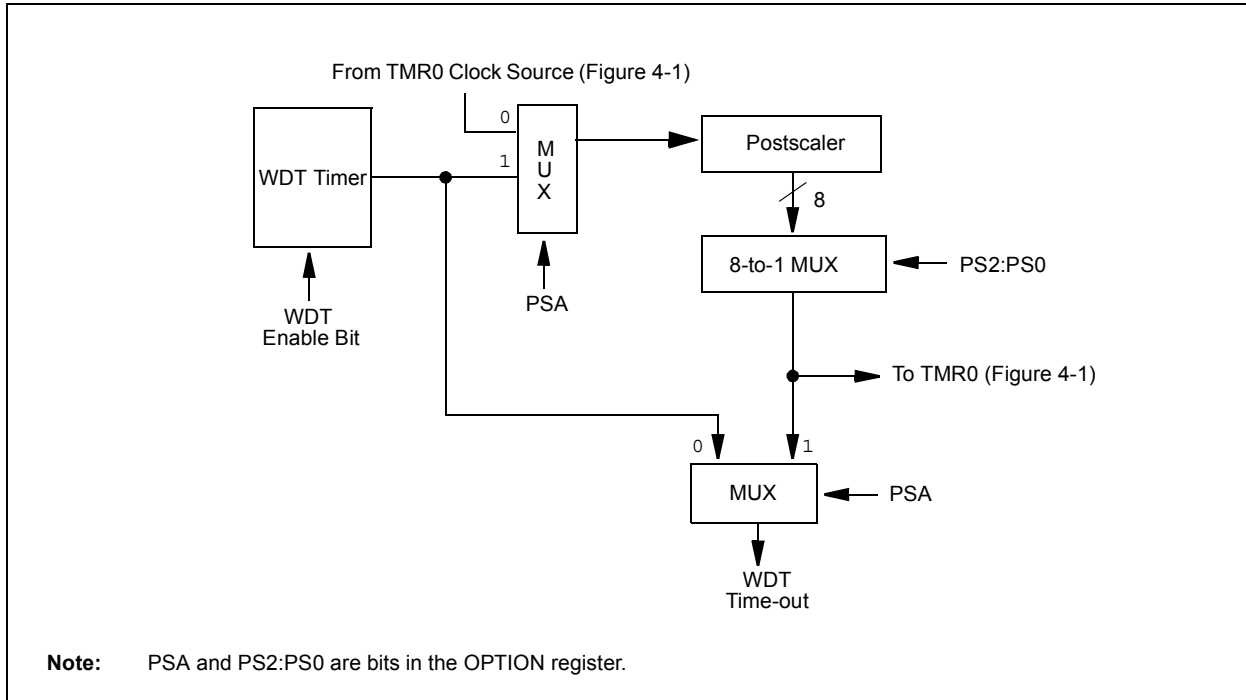
The WDT can be permanently disabled by clearing Configuration bit `WDTE` (Section 9.1 “Configuration Bits”).

WDT time-out period values may be found in the Electrical Specifications section under `TWDT` (parameter #31). Values for the WDT prescaler (actually a postscaler, but shared with the Timer0 prescaler) may be assigned using the `OPTION` register.

**Note:** The `CLRWDT` and `SLEEP` instructions clear the WDT and the postscaler, if assigned to the WDT, and prevent it from timing out and generating a device Reset condition.

**Note:** When a `CLRWDT` instruction is executed and the prescaler is assigned to the WDT, the prescaler count will be cleared, but the prescaler assignment is not changed.

**FIGURE 9-14: WATCHDOG TIMER BLOCK DIAGRAM**



**TABLE 9-7: SUMMARY OF REGISTERS ASSOCIATED WITH WATCHDOG TIMER**

Name	Bit 7	Bit 6	Bit 5	Bit 4	Bit 3	Bit 2	Bit 1	Bit 0	Value on POR, BOR	Value on all other Resets
CONFIG1 <sup>(1)</sup>	BORV	BOREN	—	—	PWRTE	WDTE	FOSC1	FOSC0	—	—
OPTION_REG	RBPV	INTEDG	T0CS	T0SE	PSA	PS2	PS1	PS0	1111 1111	1111 1111

**Legend:** x = unknown, u = unchanged, - = unimplemented locations read as '0'. Shaded cells are not used the Watchdog Timer.

**Note 1:** See Configuration Word Register (Register 9-1) for operation of all register bits.

## 9.13 Power-down Mode (Sleep)

Power-Down mode is entered by executing a `SLEEP` instruction.

If enabled, the Watchdog Timer will be cleared but keeps running, the `PD` bit of the `STATUS` register is cleared, the `TO` of the `STATUS` register bit is set, and the oscillator driver is turned off. The I/O ports maintain the status they had, before the `SLEEP` instruction was executed (driving high, low or high-impedance).

For lowest current consumption in this mode, place all I/O pins at either `VDD` or `VSS`, ensure no external circuitry is drawing current from the I/O pin, power-down the A/D and the disable external clocks. Pull all I/O pins that are high-impedance inputs, high or low externally, to avoid switching currents caused by floating inputs. The `TOCKI` input should also be at `VDD` or `VSS` for lowest current consumption. The contribution from on-chip pull-ups on `PORTB` should be considered.

The `MCLR` pin must be at a logic high level (parameter D042).

### 9.13.1 WAKE-UP FROM SLEEP

The device can wake-up from Sleep through one of the following events:

1. External Reset input on `MCLR` pin.
2. Watchdog Timer Wake-up (if `WDT` was enabled).
3. Interrupt from `INT` pin, `RB` port change or some peripheral interrupts.

External `MCLR` Reset will cause a device Reset. All other events are considered a continuation of program execution and cause a “wake-up”. The `TO` and `PD` bits in the `STATUS` register can be used to determine the cause of device Reset. The `PD` bit, which is set on power-up, is cleared when Sleep is invoked. The `TO` bit is cleared if a `WDT` time-out occurred (and caused wake-up).

The following peripheral interrupts can wake the device from Sleep:

1. `TMR1` interrupt. `Timer1` must be operating as an asynchronous counter.
2. `ECCP` capture mode interrupt.
3. `ADC` running in `ADRC` mode.

Other peripherals cannot generate interrupts, since during Sleep, no on-chip clocks are present.

When the `SLEEP` instruction is being executed, the next instruction (`PC + 1`) is pre-fetched. For the device to wake-up through an interrupt event, the corresponding interrupt enable bit must be set (enabled). Wake-up is regardless of the state of the `GIE` bit. If the `GIE` bit is clear (disabled), the device continues execution at the instruction after the `SLEEP` instruction. If the `GIE` bit is set (enabled), the device executes the instruction after the `SLEEP` instruction and then branches to the interrupt address (0004h). In cases where the execution of the instruction following `SLEEP` is not desirable, the user should have a `NOP` after the `SLEEP` instruction.

### 9.13.2 WAKE-UP USING INTERRUPTS

When global interrupts are disabled (`GIE` cleared) and any interrupt source has both its interrupt enable bit and interrupt flag bit set, one of the following will occur:

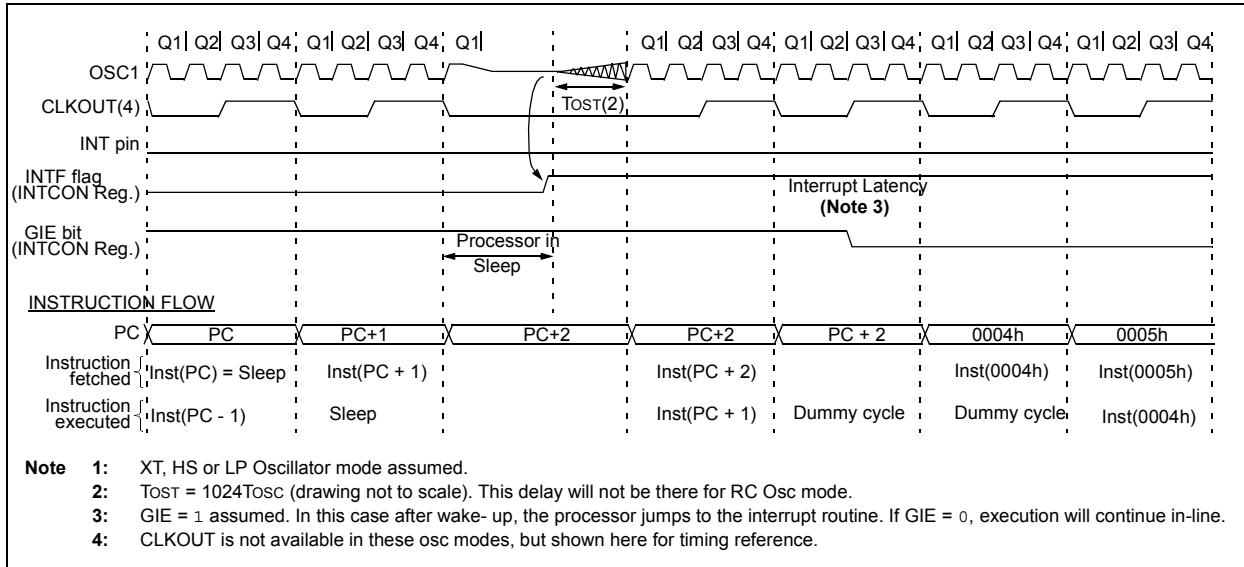
- If the interrupt occurs **before** the execution of a `SLEEP` instruction, the `SLEEP` instruction will complete as a `NOP`. Therefore, the `WDT` and `WDT` postscaler will not be cleared, the `TO` bit will not be set and `PD` bits will not be cleared.
- If the interrupt occurs **during or after** the execution of a `SLEEP` instruction, the device will immediately wake-up from Sleep. The `SLEEP` instruction will be completely executed before the wake-up. Therefore, the `WDT` and `WDT` postscaler will be cleared, the `TO` bit will be set and the `PD` bit will be cleared.

Even if the flag bits were checked before executing a `SLEEP` instruction, it may be possible for flag bits to become set before the `SLEEP` instruction completes. To determine whether a `SLEEP` instruction executed, test the `PD` bit. If the `PD` bit is set, the `SLEEP` instruction was executed as a `NOP`.

To ensure that the `WDT` is cleared, a `CLRWDT` instruction should be executed before a `SLEEP` instruction.

# PIC16F716

**FIGURE 9-15: WAKE-UP FROM SLEEP THROUGH INTERRUPT**



## 9.14 Program Verification/Code Protection

If the code protection bit has not been programmed, the on-chip program memory can be read out for verification purposes.

## 9.15 ID Locations

Four memory locations (2000h-2003h) are designated as ID locations where the user can store checksum or other code-identification numbers. These locations are not accessible during normal execution, but are readable and writable during program/verify. It is recommended that only the 4 Least Significant bits of the ID location are used.

## 9.16 In-Circuit Serial Programming™

PIC16F716 microcontrollers can be serially programmed while in the end application circuit. This is simply done with two lines for clock and data, and three other lines for power, ground and the programming voltage. This allows customers to manufacture boards with unprogrammed devices and then program the microcontroller just before shipping the product. This also allows the most recent firmware or a custom firmware to be programmed.

For complete details on serial programming, please refer to the In-Circuit Serial Programming™ (ICSP™) Specification, (DS40245).

## 10.0 INSTRUCTION SET SUMMARY

The PIC16F716 instruction set is highly orthogonal and is comprised of three basic categories:

- **Byte-oriented** operations
- **Bit-oriented** operations
- **Literal and control** operations

Each PIC16 instruction is a 14-bit word divided into an **opcode**, which specifies the instruction type and one or more **operands**, which further specify the operation of the instruction. The formats for each of the categories is presented in Figure 10-1, while the various opcode fields are summarized in Table 10-1.

Table 10-2 lists the instructions recognized by the MPASM™ assembler.

For **byte-oriented** instructions, 'f' represents a file register designator and 'd' represents a destination designator. The file register designator specifies which file register is to be used by the instruction.

The destination designator specifies where the result of the operation is to be placed. If 'd' is zero, the result is placed in the W register. If 'd' is one, the result is placed in the file register specified in the instruction.

For **bit-oriented** instructions, 'b' represents a bit field designator, which selects the bit affected by the operation, while 'f' represents the address of the file in which the bit is located.

For **literal and control** operations, 'k' represents an 8-bit or 11-bit constant, or literal value.

One instruction cycle consists of four oscillator periods; for an oscillator frequency of 4 MHz, this gives a nominal instruction execution time of 1 μs. All instructions are executed within a single instruction cycle, unless a conditional test is true, or the program counter is changed as a result of an instruction. When this occurs, the execution takes two instruction cycles, with the second cycle executed as a NOP.

All instruction examples use the format '0xhh' to represent a hexadecimal number, where 'h' signifies a hexadecimal digit.

### 10.1 Read-Modify-Write Operations

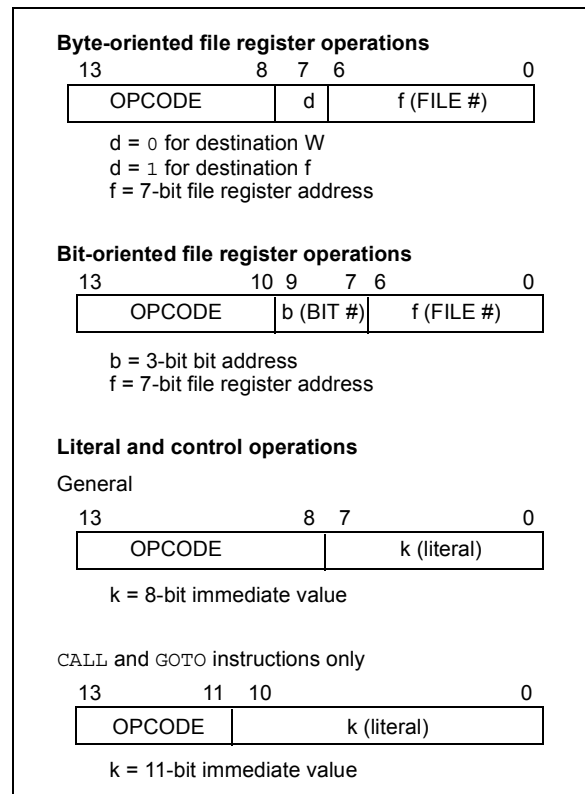
Any instruction that specifies a file register as part of the instruction performs a Read-Modify-Write (R-M-W) operation. The register is read, the data is modified, and the result is stored according to either the instruction, or the destination designator 'd'. A read operation is performed on a register even if the instruction writes to that register.

For example, a `CLRF PORTA` instruction will read PORTA, clear all the data bits, then write the result back to PORTA. This example would have the unintended consequence of clearing the condition that set the RAIF flag.

**TABLE 10-1: OPCODE FIELD DESCRIPTIONS**

Field	Description
f	Register file address (0x00 to 0x7F)
W	Working register (accumulator)
b	Bit address within an 8-bit file register
k	Literal field, constant data or label
x	Don't care location (= 0 or 1). The assembler will generate code with x = 0. It is the recommended form of use for compatibility with all Microchip software tools.
d	Destination select; d = 0: store result in W, d = 1: store result in file register f. Default is d = 1.
PC	Program Counter
$\overline{TO}$	Time-out bit
C	Carry bit
DC	Digit carry bit
Z	Zero bit
$\overline{PD}$	Power-down bit

**FIGURE 10-1: GENERAL FORMAT FOR INSTRUCTIONS**



# PIC16F716

**TABLE 10-2: PIC16F716 INSTRUCTION SET**

Mnemonic, Operands	Description	Cycles	14-Bit Opcode				Status Affected	Notes	
			MSb		LSb				
<b>BYTE-ORIENTED FILE REGISTER OPERATIONS</b>									
ADDWF	f, d	Add W and f	1	00	0111	dfff	ffff	C, DC, Z	1, 2
ANDWF	f, d	AND W with f	1	00	0101	dfff	ffff	Z	1, 2
CLRF	f	Clear f	1	00	0001	1fff	ffff	Z	2
CLRWF	–	Clear W	1	00	0001	0xxx	xxxx	Z	
COMF	f, d	Complement f	1	00	1001	dfff	ffff	Z	1, 2
DECf	f, d	Decrement f	1	00	0011	dfff	ffff	Z	1, 2
DECFSZ	f, d	Decrement f, Skip if 0	1(2)	00	1011	dfff	ffff		1, 2, 3
INCF	f, d	Increment f	1	00	1010	dfff	ffff	Z	1, 2
INCFSZ	f, d	Increment f, Skip if 0	1(2)	00	1111	dfff	ffff		1, 2, 3
IORWF	f, d	Inclusive OR W with f	1	00	0100	dfff	ffff	Z	1, 2
MOVF	f, d	Move f	1	00	1000	dfff	ffff	Z	1, 2
MOVWF	f	Move W to f	1	00	0000	1fff	ffff		
NOP	–	No Operation	1	00	0000	0xx0	0000		
RLF	f, d	Rotate Left f through Carry	1	00	1101	dfff	ffff	C	1, 2
RRF	f, d	Rotate Right f through Carry	1	00	1100	dfff	ffff	C	1, 2
SUBWF	f, d	Subtract W from f	1	00	0010	dfff	ffff	C, DC, Z	1, 2
SWAPF	f, d	Swap nibbles in f	1	00	1110	dfff	ffff		1, 2
XORWF	f, d	Exclusive OR W with f	1	00	0110	dfff	ffff	Z	1, 2
<b>BIT-ORIENTED FILE REGISTER OPERATIONS</b>									
BCF	f, b	Bit Clear f	1	01	00bb	bfff	ffff		1, 2
BSF	f, b	Bit Set f	1	01	01bb	bfff	ffff		1, 2
BTFSC	f, b	Bit Test f, Skip if Clear	1(2)	01	10bb	bfff	ffff		3
BTFSS	f, b	Bit Test f, Skip if Set	1(2)	01	11bb	bfff	ffff		3
<b>LITERAL AND CONTROL OPERATIONS</b>									
ADDLW	k	Add literal and W	1	11	111x	kkkk	kkkk	C, DC, Z	
ANDLW	k	AND literal with W	1	11	1001	kkkk	kkkk	Z	
CALL	k	Call Subroutine	2	10	0kkk	kkkk	kkkk		
CLRWDt	–	Clear Watchdog Timer	1	00	0000	0110	0100	$\overline{TO}, \overline{PD}$	
GOTO	k	Go to address	2	10	1kkk	kkkk	kkkk		
IORLW	k	Inclusive OR literal with W	1	11	1000	kkkk	kkkk	Z	
MOVLW	k	Move literal to W	1	11	00xx	kkkk	kkkk		
RETFIE	–	Return from interrupt	2	00	0000	0000	1001		
RETLW	k	Return with literal in W	2	11	01xx	kkkk	kkkk		
RETURN	–	Return from Subroutine	2	00	0000	0000	1000		
SLEEP	–	Go into Standby mode	1	00	0000	0110	0011	$\overline{TO}, \overline{PD}$	
SUBLW	k	Subtract W from literal	1	11	110x	kkkk	kkkk	C, DC, Z	
XORLW	k	Exclusive OR literal with W	1	11	1010	kkkk	kkkk	Z	

- Note 1:** When an I/O register is modified as a function of itself (e.g., MOVF GPIO, 1), the value used will be that value present on the pins themselves. For example, if the data latch is '1' for a pin configured as input and is driven low by an external device, the data will be written back with a '0'.
- 2:** If this instruction is executed on the TMR0 register (and where applicable, d = 1), the prescaler will be cleared if assigned to the Timer0 module.
- 3:** If the Program Counter (PC) is modified, or a conditional test is true, the instruction requires two cycles. The second cycle is executed as a NOP.

## 10.2 Instruction Descriptions

### **ADDLW**      **Add literal and W**

**Syntax:**      `[label] ADDLW k`

**Operands:**     $0 \leq k \leq 255$

**Operation:**     $(W) + k \rightarrow (W)$

**Status Affected:** C, DC, Z

**Description:**    The contents of the W register are added to the eight-bit literal 'k' and the result is placed in the W register.

### **BCF**            **Bit Clear f**

**Syntax:**      `[label] BCF f,b`

**Operands:**     $0 \leq f \leq 127$   
 $0 \leq b \leq 7$

**Operation:**     $0 \rightarrow (f<b>)$

**Status Affected:** None

**Description:**    Bit 'b' in register 'f' is cleared.

### **ADDWF**        **Add W and f**

**Syntax:**      `[label] ADDWF f,d`

**Operands:**     $0 \leq f \leq 127$   
 $d \in [0,1]$

**Operation:**     $(W) + (f) \rightarrow (\text{destination})$

**Status Affected:** C, DC, Z

**Description:**    Add the contents of the W register with register 'f'. If 'd' is '0', the result is stored in the W register. If 'd' is '1', the result is stored back in register 'f'.

### **BSF**            **Bit Set f**

**Syntax:**      `[label] BSF f,b`

**Operands:**     $0 \leq f \leq 127$   
 $0 \leq b \leq 7$

**Operation:**     $1 \rightarrow (f<b>)$

**Status Affected:** None

**Description:**    Bit 'b' in register 'f' is set.

### **ANDLW**        **AND literal with W**

**Syntax:**      `[label] ANDLW k`

**Operands:**     $0 \leq k \leq 255$

**Operation:**     $(W) .\text{AND.} (k) \rightarrow (W)$

**Status Affected:** Z

**Description:**    The contents of W register are AND'ed with the eight-bit literal 'k'. The result is placed in the W register.

### **BTFSC**         **Bit Test f, Skip if Clear**

**Syntax:**      `[label] BTFSC f,b`

**Operands:**     $0 \leq f \leq 127$   
 $0 \leq b \leq 7$

**Operation:**    skip if  $(f<b>) = 0$

**Status Affected:** None

**Description:**    If bit 'b' in register 'f' is '1', the next instruction is executed.  
If bit 'b', in register 'f', is '0', the next instruction is discarded, and a NOP is executed instead, making this a two-cycle instruction.

### **ANDWF**        **AND W with f**

**Syntax:**      `[label] ANDWF f,d`

**Operands:**     $0 \leq f \leq 127$   
 $d \in [0,1]$

**Operation:**     $(W) .\text{AND.} (f) \rightarrow (\text{destination})$

**Status Affected:** Z

**Description:**    AND the W register with register 'f'. If 'd' is '0', the result is stored in the W register. If 'd' is '1', the result is stored back in register 'f'.

# PIC16F716

---

## **BTFS** Bit Test f, Skip if Set

---

Syntax: [ *label* ] BTFS f,b  
Operands:  $0 \leq f \leq 127$   
 $0 \leq b < 7$   
Operation: skip if (f<b>) = 1  
Status Affected: None  
Description: If bit 'b' in register 'f' is '0', the next instruction is executed.  
If bit 'b' is '1', then the next instruction is discarded and a NOP is executed instead, making this a two-cycle instruction.

## **CALL** Call Subroutine

---

Syntax: [ *label* ] CALL k  
Operands:  $0 \leq k \leq 2047$   
Operation: (PC)+ 1 → TOS,  
k → PC<10:0>,  
(PCLATH<4:3>) → PC<12:11>  
Status Affected: None  
Description: Call Subroutine. First, return address (PC + 1) is pushed onto the stack. The eleven-bit immediate address is loaded into PC bits <10:0>. The upper bits of the PC are loaded from PCLATH. CALL is a two-cycle instruction.

## **CLRF** Clear f

---

Syntax: [ *label* ] CLRF f  
Operands:  $0 \leq f \leq 127$   
Operation: 00h → (f)  
1 → Z  
Status Affected: Z  
Description: The contents of register 'f' are cleared and the Z bit is set.

## **CLRW** Clear W

---

Syntax: [ *label* ] CLRW  
Operands: None  
Operation: 00h → (W)  
1 → Z  
Status Affected: Z  
Description: W register is cleared. Zero bit (Z) is set.

## **CLRWD** Clear Watchdog Timer

---

Syntax: [ *label* ] CLRWD  
Operands: None  
Operation: 00h → WDT  
0 → WDT prescaler,  
1 →  $\overline{TO}$   
1 →  $\overline{PD}$   
Status Affected:  $\overline{TO}$ ,  $\overline{PD}$   
Description: CLRWD instruction resets the Watchdog Timer. It also resets the prescaler of the WDT. Status bits  $\overline{TO}$  and  $\overline{PD}$  are set.

## **COMF** Complement f

---

Syntax: [ *label* ] COMF f,d  
Operands:  $0 \leq f \leq 127$   
d ∈ [0,1]  
Operation: ( $\bar{f}$ ) → (destination)  
Status Affected: Z  
Description: The contents of register 'f' are complemented. If 'd' is '0', the result is stored in W. If 'd' is '1', the result is stored back in register 'f'.

## **DECF** Decrement f

---

Syntax: [ *label* ] DECF f,d  
Operands:  $0 \leq f \leq 127$   
d ∈ [0,1]  
Operation: (f) - 1 → (destination)  
Status Affected: Z  
Description: Decrement register 'f'. If 'd' is '0', the result is stored in the W register. If 'd' is '1', the result is stored back in register 'f'.

---

## DECFSZ      Decrement f, Skip if 0

---

Syntax:            [*label*] DECFSZ f,d

Operands:         $0 \leq f \leq 127$   
 $d \in [0,1]$

Operation:         $(f) - 1 \rightarrow (\text{destination})$ ;  
 skip if result = 0

Status Affected: None

Description:     The contents of register 'f' are decremented. If 'd' is '0', the result is placed in the W register. If 'd' is '1', the result is placed back in register 'f'.  
 If the result is '1', the next instruction is executed. If the result is '0', then a NOP is executed instead, making it a two-cycle instruction.

---

## INCFSZ      Increment f, Skip if 0

---

Syntax:            [*label*] INCFSZ f,d

Operands:         $0 \leq f \leq 127$   
 $d \in [0,1]$

Operation:         $(f) + 1 \rightarrow (\text{destination})$ ,  
 skip if result = 0

Status Affected: None

Description:     The contents of register 'f' are incremented. If 'd' is '0', the result is placed in the W register. If 'd' is '1', the result is placed back in register 'f'.  
 If the result is '1', the next instruction is executed. If the result is '0', a NOP is executed instead, making it a two-cycle instruction.

---

## GOTO          Unconditional Branch

---

Syntax:            [*label*] GOTO k

Operands:         $0 \leq k \leq 2047$

Operation:         $k \rightarrow \text{PC}\langle 10:0 \rangle$   
 $\text{PCLATH}\langle 4:3 \rangle \rightarrow \text{PC}\langle 12:11 \rangle$

Status Affected: None

Description:     GOTO is an unconditional branch. The eleven-bit immediate value is loaded into PC bits  $\langle 10:0 \rangle$ . The upper bits of PC are loaded from PCLATH $\langle 4:3 \rangle$ . GOTO is a two-cycle instruction.

---

## IORLW        Inclusive OR literal with W

---

Syntax:            [*label*] IORLW k

Operands:         $0 \leq k \leq 255$

Operation:         $(W) .\text{OR. } k \rightarrow (W)$

Status Affected: Z

Description:     The contents of the W register are OR'ed with the eight-bit literal 'k'. The result is placed in the W register.

---

## INCF          Increment f

---

Syntax:            [*label*] INCF f,d

Operands:         $0 \leq f \leq 127$   
 $d \in [0,1]$

Operation:         $(f) + 1 \rightarrow (\text{destination})$

Status Affected: Z

Description:     The contents of register 'f' are incremented. If 'd' is '0', the result is placed in the W register. If 'd' is '1', the result is placed back in register 'f'.

---

## IORWF        Inclusive OR W with f

---

Syntax:            [*label*] IORWF f,d

Operands:         $0 \leq f \leq 127$   
 $d \in [0,1]$

Operation:         $(W) .\text{OR. } (f) \rightarrow (\text{destination})$

Status Affected: Z

Description:     Inclusive OR the W register with register 'f'. If 'd' is '0', the result is placed in the W register. If 'd' is '1', the result is placed back in register 'f'.

# PIC16F716

---

<b>MOVF</b>	<b>Move f</b>
Syntax:	[ <i>label</i> ] MOVF f,d
Operands:	$0 \leq f \leq 127$ $d \in [0,1]$
Operation:	(f) → (dest)
Status Affected:	Z
Description:	The contents of register f is moved to a destination dependent upon the status of d. If d = 0, destination is W register. If d = 1, the destination is file register f itself. d = 1 is useful to test a file register since status flag Z is affected.
Words:	1
Cycles:	1
Example:	<pre>MOVF    FSR, 0</pre> <p>After Instruction</p> <pre>W = value in FSR register Z = 1</pre>

<b>MOVLW</b>	<b>Move literal to W</b>
Syntax:	[ <i>label</i> ] MOVLW k
Operands:	$0 \leq k \leq 255$
Operation:	k → (W)
Status Affected:	None
Description:	The eight-bit literal 'k' is loaded into W register. The "don't cares" will assemble as '0's.
Words:	1
Cycles:	1
Example:	<pre>MOVLW  0x5A</pre> <p>After Instruction</p> <pre>W = 0x5A</pre>

<b>MOVWF</b>	<b>Move W to f</b>
Syntax:	[ <i>label</i> ] MOVWF f
Operands:	$0 \leq f \leq 127$
Operation:	(W) → (f)
Status Affected:	None
Description:	Move data from W register to register 'f'.
Words:	1
Cycles:	1
Example:	<pre>MOVWF  OPTION F</pre> <p>Before Instruction</p> <pre>OPTION = 0xFF W      = 0x4F</pre> <p>After Instruction</p> <pre>OPTION = 0x4F W      = 0x4F</pre>

<b>NOP</b>	<b>No Operation</b>
Syntax:	[ <i>label</i> ] NOP
Operands:	None
Operation:	No operation
Status Affected:	None
Description:	No operation.
Words:	1
Cycles:	1
Example:	<pre>NOP</pre>

<b>RETFIE</b>	<b>Return from Interrupt</b>
Syntax:	[ <i>label</i> ] RETFIE
Operands:	None
Operation:	TOS → PC, 1 → GIE
Status Affected:	None
Description:	Return from Interrupt. Stack is POPed and Top-of-Stack (TOS) is loaded in the PC. Interrupts are enabled by setting Global Interrupt Enable bit, GIE (INTCON<7>). This is a two-cycle instruction.
Words:	1
Cycles:	2
<u>Example:</u>	<pre> RETFIE After Interrupt     PC =  TOS     GIE =  1 </pre>

<b>RETLW</b>	<b>Return with literal in W</b>
Syntax:	[ <i>label</i> ] RETLW k
Operands:	0 ≤ k ≤ 255
Operation:	k → (W); TOS → PC
Status Affected:	None
Description:	The W register is loaded with the eight bit literal 'k'. The program counter is loaded from the top of the stack (the return address). This is a two-cycle instruction.
Words:	1
Cycles:	2
<u>Example:</u>	<pre> CALL TABLE;W contains table                 ;offset value                 ;W now has table value                 .                 .                 . ADDWF PC ;W = offset RETLW k1 ;Begin table RETLW k2 ;                 .                 .                 . RETLW kn ; End of table </pre>
	<p>Before Instruction W = 0x07</p> <p>After Instruction W = value of k8</p>

<b>RETURN</b>	<b>Return from Subroutine</b>
Syntax:	[ <i>label</i> ] RETURN
Operands:	None
Operation:	TOS → PC
Status Affected:	None
Description:	Return from subroutine. The stack is POPed and the top of the stack (TOS) is loaded into the program counter. This is a two-cycle instruction.

# PIC16F716

## RLF Rotate Left f through Carry

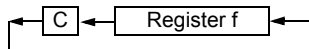
**Syntax:** `[label] RLF f,d`

**Operands:**  $0 \leq f \leq 127$   
 $d \in [0,1]$

**Operation:** See description below

**Status Affected:** C

**Description:** The contents of register 'f' are rotated one bit to the left through the Carry flag. If 'd' is '0', the result is placed in the W register. If 'd' is '1', the result is stored back in register 'f'.



**Words:** 1

**Cycles:** 1

**Example:**

```

RLF    REG1,0

Before Instruction
REG1   = 1110 0110
C      = 0

After Instruction
REG1   = 1110 0110
W      = 1100 1100
C      = 1
    
```

## SLEEP Enter Sleep mode

**Syntax:** `[label] SLEEP`

**Operands:** None

**Operation:** 00h → WDT,  
 0 → WDT prescaler,  
 1 →  $\overline{TO}$ ,  
 0 →  $\overline{PD}$

**Status Affected:**  $\overline{TO}$ ,  $\overline{PD}$

**Description:** The power-down Status bit,  $\overline{PD}$  is cleared. Time-out Status bit,  $\overline{TO}$  is set. Watchdog Timer and its prescaler are cleared. The processor is put into Sleep mode with the oscillator stopped.

## RRF Rotate Right f through Carry

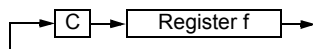
**Syntax:** `[label] RRF f,d`

**Operands:**  $0 \leq f \leq 127$   
 $d \in [0,1]$

**Operation:** See description below

**Status Affected:** C

**Description:** The contents of register 'f' are rotated one bit to the right through the Carry flag. If 'd' is '0', the result is placed in the W register. If 'd' is '1', the result is placed back in register 'f'.



## SUBLW Subtract W from literal

**Syntax:** `[label] SUBLW k`

**Operands:**  $0 \leq k \leq 255$

**Operation:**  $k - (W) \rightarrow (W)$

**Status Affected:** C, DC, Z

**Description:** The W register is subtracted (2's complement method) from the eight-bit literal 'k'. The result is placed in the W register.

C = 0	$W > k$
C = 1	$W \leq k$
DC = 0	$W\langle 3:0 \rangle > k\langle 3:0 \rangle$
DC = 1	$W\langle 3:0 \rangle \leq k\langle 3:0 \rangle$

## **SUBWF**      **Subtract W from f**

Syntax:      [*label*] SUBWF f,d

Operands:     $0 \leq f \leq 127$   
 $d \in [0,1]$

Operation:     $(f) - (W) \rightarrow (\text{destination})$

Status Affected: C, DC, Z

Description:    Subtract (2's complement method) W register from register 'f'. If 'd' is '0', the result is stored in the W register. If 'd' is '1', the result is stored back in register 'f'.

C = 0	$W > f$
C = 1	$W \leq f$
DC = 0	$W\langle 3:0 \rangle > f\langle 3:0 \rangle$
DC = 1	$W\langle 3:0 \rangle \leq f\langle 3:0 \rangle$

## **SWAPF**      **Swap Nibbles in f**

Syntax:      [*label*] SWAPF f,d

Operands:     $0 \leq f \leq 127$   
 $d \in [0,1]$

Operation:     $(f\langle 3:0 \rangle) \rightarrow (\text{destination}\langle 7:4 \rangle)$ ,  
 $(f\langle 7:4 \rangle) \rightarrow (\text{destination}\langle 3:0 \rangle)$

Status Affected: None

Description:    The upper and lower nibbles of register 'f' are exchanged. If 'd' is '0', the result is placed in the W register. If 'd' is '1', the result is placed in register 'f'.

## **XORLW**      **Exclusive OR literal with W**

Syntax:      [*label*] XORLW k

Operands:     $0 \leq k \leq 255$

Operation:     $(W) .XOR. k \rightarrow (W)$

Status Affected: Z

Description:    The contents of the W register are XOR'ed with the eight-bit literal 'k'. The result is placed in the W register.

## **XORWF**      **Exclusive OR W with f**

Syntax:      [*label*] XORWF f,d

Operands:     $0 \leq f \leq 127$   
 $d \in [0,1]$

Operation:     $(W) .XOR. (f) \rightarrow (\text{destination})$

Status Affected: Z

Description:    Exclusive OR the contents of the W register with register 'f'. If 'd' is '0', the result is stored in the W register. If 'd' is '1', the result is stored back in register 'f'.

# PIC16F716

---

NOTES:

## 11.0 DEVELOPMENT SUPPORT

The PIC<sup>®</sup> microcontrollers are supported with a full range of hardware and software development tools:

- Integrated Development Environment
  - MPLAB<sup>®</sup> IDE Software
- Assemblers/Compilers/Linkers
  - MPASM<sup>™</sup> Assembler
  - MPLAB C18 and MPLAB C30 C Compilers
  - MPLINK<sup>™</sup> Object Linker/  
MPLIB<sup>™</sup> Object Librarian
  - MPLAB ASM30 Assembler/Linker/Library
- Simulators
  - MPLAB SIM Software Simulator
- Emulators
  - MPLAB ICE 2000 In-Circuit Emulator
  - MPLAB REAL ICE<sup>™</sup> In-Circuit Emulator
- In-Circuit Debugger
  - MPLAB ICD 2
- Device Programmers
  - PICSTART<sup>®</sup> Plus Development Programmer
  - MPLAB PM3 Device Programmer
  - PICKit<sup>™</sup> 2 Development Programmer
- Low-Cost Demonstration and Development Boards and Evaluation Kits

## 11.1 MPLAB Integrated Development Environment Software

The MPLAB IDE software brings an ease of software development previously unseen in the 8/16-bit microcontroller market. The MPLAB IDE is a Windows<sup>®</sup> operating system-based application that contains:

- A single graphical interface to all debugging tools
  - Simulator
  - Programmer (sold separately)
  - Emulator (sold separately)
  - In-Circuit Debugger (sold separately)
- A full-featured editor with color-coded context
- A multiple project manager
- Customizable data windows with direct edit of contents
- High-level source code debugging
- Visual device initializer for easy register initialization
- Mouse over variable inspection
- Drag and drop variables from source to watch windows
- Extensive on-line help
- Integration of select third party tools, such as HI-TECH Software C Compilers and IAR C Compilers

The MPLAB IDE allows you to:

- Edit your source files (either assembly or C)
- One touch assemble (or compile) and download to PIC MCU emulator and simulator tools (automatically updates all project information)
- Debug using:
  - Source files (assembly or C)
  - Mixed assembly and C
  - Machine code

MPLAB IDE supports multiple debugging tools in a single development paradigm, from the cost-effective simulators, through low-cost in-circuit debuggers, to full-featured emulators. This eliminates the learning curve when upgrading to tools with increased flexibility and power.

# PIC16F716

---

## 11.2 MPASM Assembler

The MPASM Assembler is a full-featured, universal macro assembler for all PIC MCUs.

The MPASM Assembler generates relocatable object files for the MPLINK Object Linker, Intel® standard HEX files, MAP files to detail memory usage and symbol reference, absolute LST files that contain source lines and generated machine code and COFF files for debugging.

The MPASM Assembler features include:

- Integration into MPLAB IDE projects
- User-defined macros to streamline assembly code
- Conditional assembly for multi-purpose source files
- Directives that allow complete control over the assembly process

## 11.3 MPLAB C18 and MPLAB C30 C Compilers

The MPLAB C18 and MPLAB C30 Code Development Systems are complete ANSI C compilers for Microchip's PIC18 and PIC24 families of microcontrollers and the dsPIC30 and dsPIC33 family of digital signal controllers. These compilers provide powerful integration capabilities, superior code optimization and ease of use not found with other compilers.

For easy source level debugging, the compilers provide symbol information that is optimized to the MPLAB IDE debugger.

## 11.4 MPLINK Object Linker/ MPLIB Object Librarian

The MPLINK Object Linker combines relocatable objects created by the MPASM Assembler and the MPLAB C18 C Compiler. It can link relocatable objects from precompiled libraries, using directives from a linker script.

The MPLIB Object Librarian manages the creation and modification of library files of precompiled code. When a routine from a library is called from a source file, only the modules that contain that routine will be linked in with the application. This allows large libraries to be used efficiently in many different applications.

The object linker/library features include:

- Efficient linking of single libraries instead of many smaller files
- Enhanced code maintainability by grouping related modules together
- Flexible creation of libraries with easy module listing, replacement, deletion and extraction

## 11.5 MPLAB ASM30 Assembler, Linker and Librarian

MPLAB ASM30 Assembler produces relocatable machine code from symbolic assembly language for dsPIC30F devices. MPLAB C30 C Compiler uses the assembler to produce its object file. The assembler generates relocatable object files that can then be archived or linked with other relocatable object files and archives to create an executable file. Notable features of the assembler include:

- Support for the entire dsPIC30F instruction set
- Support for fixed-point and floating-point data
- Command line interface
- Rich directive set
- Flexible macro language
- MPLAB IDE compatibility

## 11.6 MPLAB SIM Software Simulator

The MPLAB SIM Software Simulator allows code development in a PC-hosted environment by simulating the PIC MCUs and dsPIC® DSCs on an instruction level. On any given instruction, the data areas can be examined or modified and stimuli can be applied from a comprehensive stimulus controller. Registers can be logged to files for further run-time analysis. The trace buffer and logic analyzer display extend the power of the simulator to record and track program execution, actions on I/O, most peripherals and internal registers.

The MPLAB SIM Software Simulator fully supports symbolic debugging using the MPLAB C18 and MPLAB C30 C Compilers, and the MPASM and MPLAB ASM30 Assemblers. The software simulator offers the flexibility to develop and debug code outside of the hardware laboratory environment, making it an excellent, economical software development tool.

## 11.7 MPLAB ICE 2000 High-Performance In-Circuit Emulator

The MPLAB ICE 2000 In-Circuit Emulator is intended to provide the product development engineer with a complete microcontroller design tool set for PIC microcontrollers. Software control of the MPLAB ICE 2000 In-Circuit Emulator is advanced by the MPLAB Integrated Development Environment, which allows editing, building, downloading and source debugging from a single environment.

The MPLAB ICE 2000 is a full-featured emulator system with enhanced trace, trigger and data monitoring features. Interchangeable processor modules allow the system to be easily reconfigured for emulation of different processors. The architecture of the MPLAB ICE 2000 In-Circuit Emulator allows expansion to support new PIC microcontrollers.

The MPLAB ICE 2000 In-Circuit Emulator system has been designed as a real-time emulation system with advanced features that are typically found on more expensive development tools. The PC platform and Microsoft® Windows® 32-bit operating system were chosen to best make these features available in a simple, unified application.

## 11.8 MPLAB REAL ICE In-Circuit Emulator System

MPLAB REAL ICE In-Circuit Emulator System is Microchip's next generation high-speed emulator for Microchip Flash DSC® and MCU devices. It debugs and programs PIC® and dsPIC® Flash microcontrollers with the easy-to-use, powerful graphical user interface of the MPLAB Integrated Development Environment (IDE), included with each kit.

The MPLAB REAL ICE probe is connected to the design engineer's PC using a high-speed USB 2.0 interface and is connected to the target with either a connector compatible with the popular MPLAB ICD 2 system (RJ11) or with the new high speed, noise tolerant, low-voltage differential signal (LVDS) interconnection (CAT5).

MPLAB REAL ICE is field upgradeable through future firmware downloads in MPLAB IDE. In upcoming releases of MPLAB IDE, new devices will be supported, and new features will be added, such as software breakpoints and assembly code trace. MPLAB REAL ICE offers significant advantages over competitive emulators including low-cost, full-speed emulation, real-time variable watches, trace analysis, complex breakpoints, a ruggedized probe interface and long (up to three meters) interconnection cables.

## 11.9 MPLAB ICD 2 In-Circuit Debugger

Microchip's In-Circuit Debugger, MPLAB ICD 2, is a powerful, low-cost, run-time development tool, connecting to the host PC via an RS-232 or high-speed USB interface. This tool is based on the Flash PIC MCUs and can be used to develop for these and other PIC MCUs and dsPIC DSCs. The MPLAB ICD 2 utilizes the in-circuit debugging capability built into the Flash devices. This feature, along with Microchip's In-Circuit Serial Programming™ (ICSP™) protocol, offers cost-effective, in-circuit Flash debugging from the graphical user interface of the MPLAB Integrated Development Environment. This enables a designer to develop and debug source code by setting breakpoints, single stepping and watching variables, and CPU status and peripheral registers. Running at full speed enables testing hardware and applications in real time. MPLAB ICD 2 also serves as a development programmer for selected PIC devices.

## 11.10 MPLAB PM3 Device Programmer

The MPLAB PM3 Device Programmer is a universal, CE compliant device programmer with programmable voltage verification at VDDMIN and VDDMAX for maximum reliability. It features a large LCD display (128 x 64) for menus and error messages and a modular, detachable socket assembly to support various package types. The ICSP™ cable assembly is included as a standard item. In Stand-Alone mode, the MPLAB PM3 Device Programmer can read, verify and program PIC devices without a PC connection. It can also set code protection in this mode. The MPLAB PM3 connects to the host PC via an RS-232 or USB cable. The MPLAB PM3 has high-speed communications and optimized algorithms for quick programming of large memory devices and incorporates an SD/MMC card for file storage and secure data applications.

# PIC16F716

---

## 11.11 PICSTART Plus Development Programmer

The PICSTART Plus Development Programmer is an easy-to-use, low-cost, prototype programmer. It connects to the PC via a COM (RS-232) port. MPLAB Integrated Development Environment software makes using the programmer simple and efficient. The PICSTART Plus Development Programmer supports most PIC devices in DIP packages up to 40 pins. Larger pin count devices, such as the PIC16C92X and PIC17C76X, may be supported with an adapter socket. The PICSTART Plus Development Programmer is CE compliant.

## 11.12 PICkit 2 Development Programmer

The PICkit™ 2 Development Programmer is a low-cost programmer and selected Flash device debugger with an easy-to-use interface for programming many of Microchip's baseline, mid-range and PIC18F families of Flash memory microcontrollers. The PICkit 2 Starter Kit includes a prototyping development board, twelve sequential lessons, software and HI-TECH's PICC™ Lite C compiler, and is designed to help get up to speed quickly using PIC® microcontrollers. The kit provides everything needed to program, evaluate and develop applications using Microchip's powerful, mid-range Flash memory family of microcontrollers.

## 11.13 Demonstration, Development and Evaluation Boards

A wide variety of demonstration, development and evaluation boards for various PIC MCUs and dsPIC DSCs allows quick application development on fully functional systems. Most boards include prototyping areas for adding custom circuitry and provide application firmware and source code for examination and modification.

The boards support a variety of features, including LEDs, temperature sensors, switches, speakers, RS-232 interfaces, LCD displays, potentiometers and additional EEPROM memory.

The demonstration and development boards can be used in teaching environments, for prototyping custom circuits and for learning about various microcontroller applications.

In addition to the PICDEM™ and dsPICDEM™ demonstration/development board series of circuits, Microchip has a line of evaluation kits and demonstration software for analog filter design, KEELOQ® security ICs, CAN, IrDA®, PowerSmart® battery management, SEEVAL® evaluation system, Sigma-Delta ADC, flow rate sensing, plus many more.

Check the Microchip web page ([www.microchip.com](http://www.microchip.com)) and the latest "Product Selector Guide" (DS00148) for the complete list of demonstration, development and evaluation kits.

## 12.0 ELECTRICAL CHARACTERISTICS

### Absolute Maximum Ratings<sup>(†)</sup>

Ambient temperature under bias .....	-55°C to +125°C
Storage temperature .....	-65°C to +150°C
Voltage on any pin with respect to V <sub>SS</sub> (except V <sub>DD</sub> , $\overline{\text{MCLR}}$ , and RA4) .....	-0.3V to (V <sub>DD</sub> +0.3V)
Voltage on V <sub>DD</sub> with respect to V <sub>SS</sub> .....	-0.3V to +7.5V
Voltage on $\overline{\text{MCLR}}$ with respect to V <sub>SS</sub> ( <b>Note 2</b> ) .....	0V to +13.25V
Voltage on RA4 with respect to V <sub>SS</sub> .....	0V to +8.5V
Total power dissipation ( <b>Note 1</b> ) (PDIP and SOIC) .....	1.0W
Total power dissipation ( <b>Note 1</b> ) (SSOP) .....	0.65W
Maximum current out of V <sub>SS</sub> pin .....	300 mA
Maximum current into V <sub>DD</sub> pin .....	250 mA
Input clamp current, I <sub>IK</sub> (V <sub>I</sub> < 0 or V <sub>I</sub> > V <sub>DD</sub> ) .....	±20 mA
Output clamp current, I <sub>OK</sub> (V <sub>O</sub> < 0 or V <sub>O</sub> > V <sub>DD</sub> ) .....	±20 mA
Maximum output current sunk by any I/O pin .....	25 mA
Maximum output current sourced by any I/O pin .....	25 mA
Maximum current sunk by PORTA and PORTB (combined) .....	200 mA
Maximum current sourced by PORTA and PORTB (combined) .....	200 mA

**Note 1:** Power dissipation is calculated as follows:  $P_{dis} = V_{DD} \times \{I_{DD} - \sum I_{OH}\} + \sum \{(V_{DD} - V_{OH}) \times I_{OH}\} + \sum (V_{OL} \times I_{OL})$

**2:** Voltage spikes below V<sub>SS</sub> at the  $\overline{\text{MCLR}}/\text{VPP}$  pin, inducing currents greater than 80 mA, may cause latch-up. Thus, a series resistor of 50-100Ω should be used when applying a “low” level to the  $\overline{\text{MCLR}}/\text{VPP}$  pin rather than pulling this pin directly to V<sub>SS</sub>.

† NOTICE: Stresses above those listed under “Absolute Maximum Ratings” may cause permanent damage to the device. This is a stress rating only and functional operation of the device at those or any other conditions above those indicated in the operation listings of this specification is not implied. Exposure to maximum rating conditions for extended periods may affect device reliability.

# PIC16F716

FIGURE 12-1: PIC16F716 VOLTAGE-FREQUENCY GRAPH,  $-40^{\circ}\text{C} \leq \text{TA} \leq +85^{\circ}\text{C}^{(1)}$

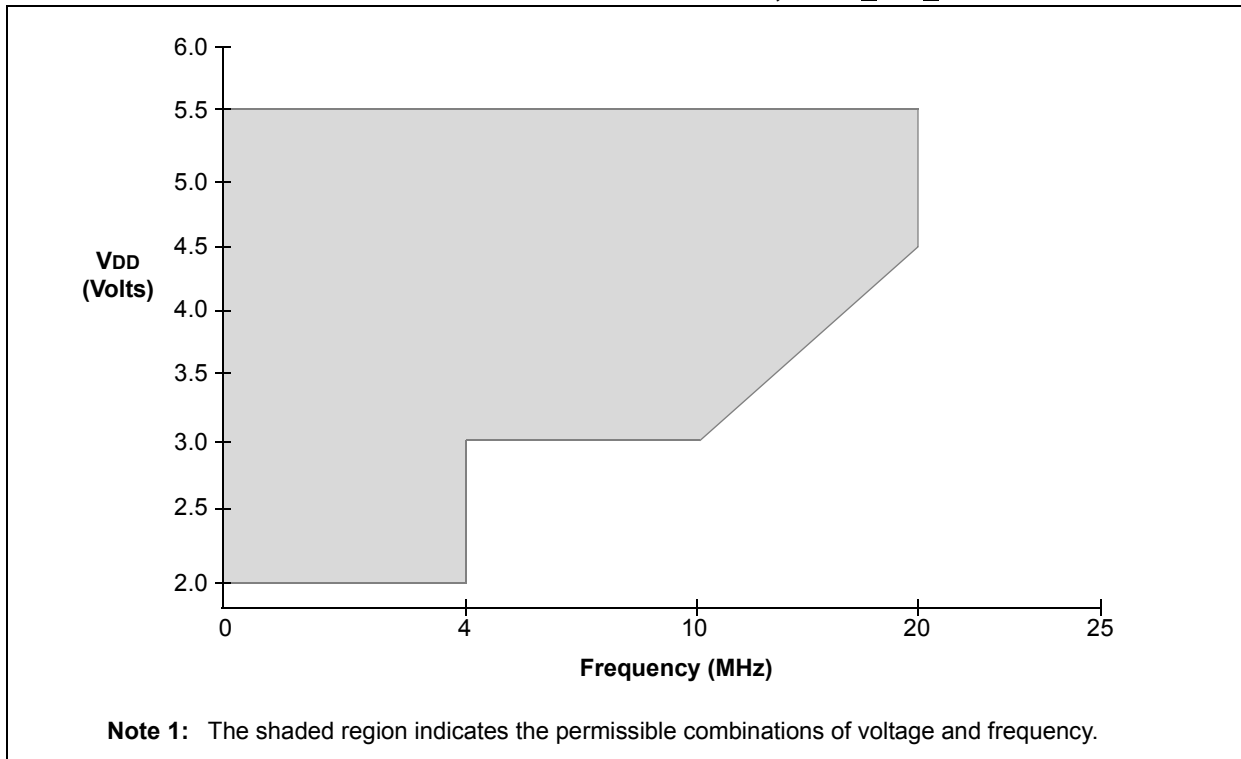
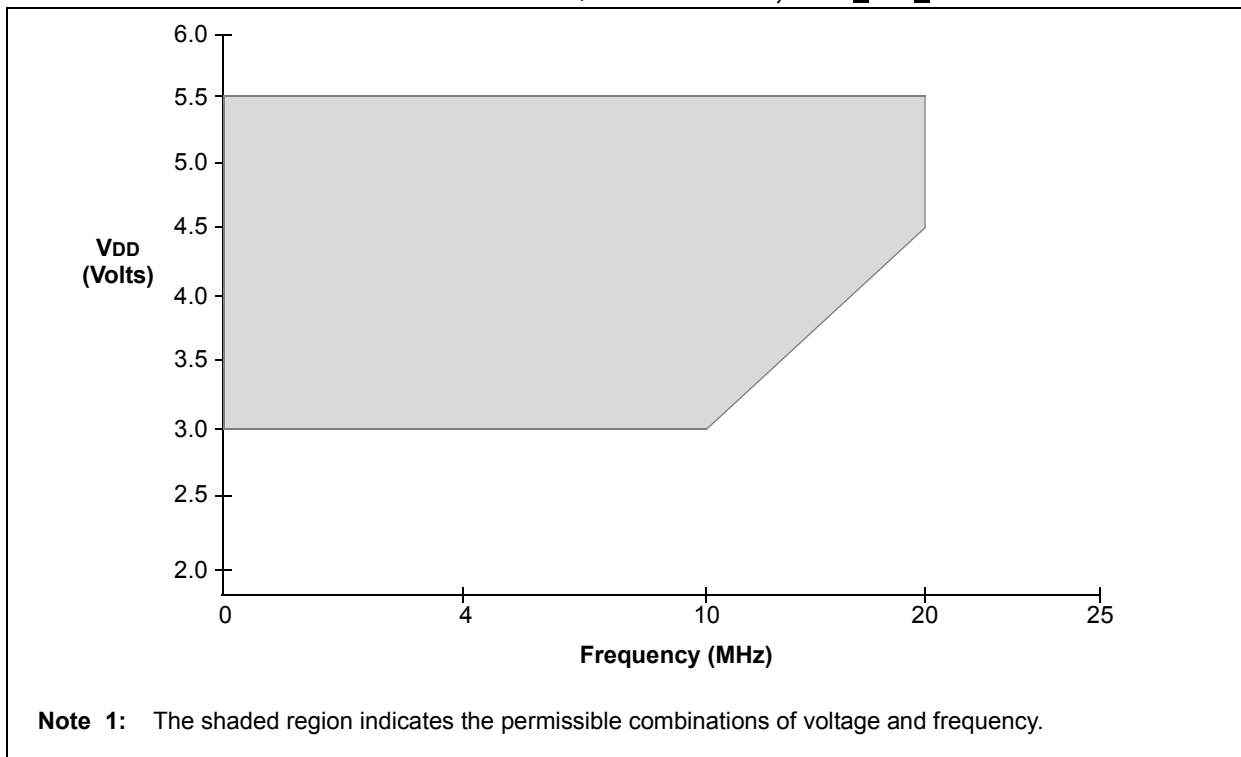


FIGURE 12-2: PIC16F716 VOLTAGE-FREQUENCY GRAPH,  $85^{\circ}\text{C} \leq \text{TA} \leq +125^{\circ}\text{C}^{(1)}$



## 12.1 DC Characteristics: PIC16F716 (Industrial, Extended)

DC CHARACTERISTICS			Standard Operating Conditions (unless otherwise stated) Operating temperature $-40^{\circ}\text{C} \leq T_A \leq +85^{\circ}\text{C}$ for industrial $-40^{\circ}\text{C} \leq T_A \leq +125^{\circ}\text{C}$ for extended				
Param No.	Sym	Characteristic	Min	Typ†	Max	Units	Conditions
D001 D001A	VDD	<b>Supply Voltage</b>					
			2.0 3.0	— —	5.5 5.5	V V	Industrial Extended
D002*	VDR	<b>RAM Data Retention Voltage<sup>(1)</sup></b>	—	1.5*	—	V	
D003	VPOR	<b>VDD Start Voltage</b> to ensure internal Power-on Reset signal	—	Vss	—	V	See section on Power-on Reset for details
D004*	SVDD	<b>VDD Rise Rate</b> to ensure internal Power-on Reset signal	0.05	—	—	V/ms	PWRT enabled (PWRT $\overline{\text{E}}$ bit clear)
D005	VBOR	<b>Brown-out Reset</b> voltage trip point					
			3.65	4.0	4.35	V	BOREN bit set, BOR bit = '1'
			2.2	2.5	2.7	V	BOREN bit set, BOR bit = '0'

\* These parameters are characterized but not tested.

† Data in "Typ" column is at 5V, 25°C unless otherwise stated. These parameters are for design guidance only and are not tested.

**Note 1:** This is the limit to which VDD can be lowered without losing RAM data.

# PIC16F716

## 12.2 DC Characteristics: PIC16F716 (Industrial)

DC CHARACTERISTICS			Standard Operating Conditions (unless otherwise stated) Operating temperature $-40^{\circ}\text{C} \leq T_A \leq +85^{\circ}\text{C}$					
Param No.	Sym	Characteristic	Min	Typ†	Max	Units	VDD	Conditions
D001	VDD	Supply Voltage						
			2.0	—	5.5	V	—	
D010	IDD	Supply Current						
			—	14	17	$\mu\text{A}$	2.0	Fosc = 32 kHz LP Oscillator mode
			—	23	28	$\mu\text{A}$	3.0	
			—	45	63.7	$\mu\text{A}$	5.0	
D011			—	120	160	$\mu\text{A}$	2.0	Fosc = 1 MHz XT Oscillator mode
			—	180	250	$\mu\text{A}$	3.0	
			—	290	370	$\mu\text{A}$	5.0	
D012			—	220	300	$\mu\text{A}$	2.0	Fosc = 4 MHz XT Oscillator mode
			—	350	470	$\mu\text{A}$	3.0	
			—	600	780	$\mu\text{A}$	5.0	
D013			—	2.1	2.9	mA	4.5	Fosc = 20 MHz HS Oscillator mode
			—	2.5	3.3	mA	5.0	
D020	IPD	Power-down Base Current						
			—	0.1	0.8	$\mu\text{A}$	2.0	WDT, BOR and T1OSC: disabled
			—	0.1	0.85	$\mu\text{A}$	3.0	
	—	0.2	2.7	$\mu\text{A}$	5.0			
D021		Peripheral Module Current <sup>(1)</sup>						
			—	1	2.0	$\mu\text{A}$	2.0	WDT Current
			—	2	3.5	$\mu\text{A}$	3.0	
	—	9	13.5	$\mu\text{A}$	5.0			
D022			—	37	50	$\mu\text{A}$	3.0	BOR Current
			—	40	55	$\mu\text{A}$	4.5	
			—	45	60	$\mu\text{A}$	5.0	
D025			—	1.8	6	$\mu\text{A}$	2.0	T1osc Current
			—	2.6	7.5	$\mu\text{A}$	3.0	
			—	3.0	9	$\mu\text{A}$	5.0	

† Data in "Typ" column is at 5V, 25°C unless otherwise stated. These parameters are for design guidance only and are not tested.

**Note 1:** The peripheral current is the sum of the base IDD or IPD and the additional current consumed when this peripheral is enabled. The peripheral "Δ" current can be determined by subtracting the base IDD or IPD current from this limit.

## 12.3 DC Characteristics: PIC16F716 (Extended)

DC CHARACTERISTICS			Standard Operating Conditions (unless otherwise stated) Operating temperature $-40^{\circ}\text{C} \leq T_A \leq +125^{\circ}\text{C}$					
Param No.	Sym	Characteristic	Min	Typ†	Max	Units	VDD	Conditions
D001	VDD	<b>Supply Voltage</b>						
			3.0	—	5.5	V	—	
D010E	IDD	<b>Supply Current</b>						
			—	21	28	$\mu\text{A}$	3.0	Fosc = 32 kHz LP Oscillator mode
D011E			—	182	250	$\mu\text{A}$	3.0	Fosc = 1 MHz XT Oscillator mode
			—	293	370	$\mu\text{A}$	5.0	
D012E			—	371	470	$\mu\text{A}$	3.0	Fosc = 4 MHz XT Oscillator mode
			—	668	780	$\mu\text{A}$	5.0	
D013E			—	2.6	2.9	mA	4.5	Fosc = 20 MHz HS Oscillator mode
			—	3	3.3	mA	5.0	
D020E	IPD	<b>Power-down Base Current</b>						
			—	0.1	11	$\mu\text{A}$	3.0	WDT, BOR and T1OSC: disabled
		—	0.2	15	$\mu\text{A}$	5.0		
D021E		<b>Peripheral Module Current<sup>(1)</sup></b>						
			—	2	19	$\mu\text{A}$	3.0	WDT Current
		—	9	22	$\mu\text{A}$	5.0		
D022E			—	37	60	$\mu\text{A}$	3.0	BOR Current
			—	40	71	$\mu\text{A}$	4.5	
			—	45	76	$\mu\text{A}$	5.0	
D025E			—	2.6	20	$\mu\text{A}$	3.0	T1osc Current
			—	3.0	25	$\mu\text{A}$	5.0	

† Data in “Typ” column is at 5V, 25°C unless otherwise stated. These parameters are for design guidance only and are not tested.

**Note 1:** The peripheral current is the sum of the base IDD or IPD and the additional current consumed when this peripheral is enabled. The peripheral “ $\Delta$ ” current can be determined by subtracting the base IDD or IPD current from this limit.

# PIC16F716

## 12.4 DC Characteristics: PIC16F716 (Industrial, Extended)

DC CHARACTERISTICS		Standard Operating Conditions (unless otherwise stated)						
		Operating temperature $-40^{\circ}\text{C} \leq T_A \leq +85^{\circ}\text{C}$ for industrial $-40^{\circ}\text{C} \leq T_A \leq +125^{\circ}\text{C}$ for extended						
		Operating voltage $V_{DD}$ range as described in DC spec Section 12.1 "DC Characteristics: PIC16F716 (Industrial, Extended)" and Section 12.4 "DC Characteristics: PIC16F716 (Industrial, Extended)".						
Param No.	Sym	Characteristic	Min	Typ†	Max	Units	Conditions	
<b>Input Low Voltage</b>								
D030	V <sub>IL</sub>	I/O ports	V <sub>SS</sub>	—	0.8	V	$4.5\text{V} \leq V_{DD} \leq 5.5\text{V}$ otherwise	
D030A		with TTL buffer	V <sub>SS</sub>	—	0.15 V <sub>DD</sub>	V		
D031		with Schmitt Trigger buffer	V <sub>SS</sub>	—	0.2 V <sub>DD</sub>	V		
D032		MCLR, OSC1 (in RC mode)	V <sub>SS</sub>	—	0.2 V <sub>DD</sub>	V		
D033		OSC1 (in HS mode) OSC1 (in XT and LP modes)	V <sub>SS</sub>	—	0.3 V <sub>DD</sub> 0.6	V		(Note1)
<b>Input High Voltage</b>								
D040	V <sub>IH</sub>	I/O ports	2.0	—	V <sub>DD</sub>	V	$4.5\text{V} \leq V_{DD} \leq 5.5\text{V}$ otherwise	
D040A		with TTL buffer	0.25 V <sub>DD</sub> + 0.8V	—	V <sub>DD</sub>	V		
D041		with Schmitt Trigger buffer	0.8 V <sub>DD</sub>	—	V <sub>DD</sub>	V		For entire V <sub>DD</sub> range
D042		MCLR	0.8 V <sub>DD</sub>	—	V <sub>DD</sub>	V		
D042A		OSC1 (XT, HS and LP modes)	0.7 V <sub>DD</sub>	—	V <sub>DD</sub>	V		
D043	OSC1 (in RC mode)	0.9 V <sub>DD</sub>	—	V <sub>DD</sub>	V	(Note1)		
<b>Input Leakage Current<sup>(2), (3)</sup></b>								
D060	I <sub>IL</sub>	I/O ports	—	—	±1	μA	V <sub>SS</sub> ≤ V <sub>PIN</sub> ≤ V <sub>DD</sub> , Pin at high-impedance	
					±500	nA	V <sub>SS</sub> ≤ V <sub>PIN</sub> ≤ V <sub>DD</sub> , Pin configured as analog input	
D061		MCLR, RA4/T0CKI	—	—	±5	μA	V <sub>SS</sub> ≤ V <sub>PIN</sub> ≤ V <sub>DD</sub>	
D063	OSC1/CLKIN	—	—	±5	μA	V <sub>SS</sub> ≤ V <sub>PIN</sub> ≤ V <sub>DD</sub> , XT, HS and LP osc modes		
D070	IPURB	<b>PORTB weak pull-up current</b>	50	250	400	μA	V <sub>DD</sub> = 5V, V <sub>PIN</sub> = V <sub>SS</sub>	
<b>Output Low Voltage</b>								
D080	V <sub>OL</sub>	I/O ports	—	—	0.6	V	I <sub>OL</sub> = 8.5 mA, V <sub>DD</sub> = 4.5V, $-40^{\circ}\text{C}$ to $+85^{\circ}\text{C}$	
					0.6	V	I <sub>OL</sub> = 7.0 mA, V <sub>DD</sub> = 4.5V, $-40^{\circ}\text{C}$ to $+125^{\circ}\text{C}$	
D083		OSC2/CLKOUT (RC Osc mode)	—	—	0.6	V	I <sub>OL</sub> = 1.6 mA, V <sub>DD</sub> = 4.5V, $-40^{\circ}\text{C}$ to $+85^{\circ}\text{C}$	
					0.6	V	I <sub>OL</sub> = 1.2 mA, V <sub>DD</sub> = 4.5V, $-40^{\circ}\text{C}$ to $+125^{\circ}\text{C}$	
<b>Output High Voltage</b>								
D090	V <sub>OH</sub>	I/O ports <sup>(3)</sup>	V <sub>DD</sub> -0.7	—	—	V	I <sub>OH</sub> = -3.0 mA, V <sub>DD</sub> = 4.5V, $-40^{\circ}\text{C}$ to $+85^{\circ}\text{C}$	
			V <sub>DD</sub> -0.7	—	—	V	I <sub>OH</sub> = -2.5 mA, V <sub>DD</sub> = 4.5V, $-40^{\circ}\text{C}$ to $+125^{\circ}\text{C}$	
D092		OSC2/CLKOUT (RC Osc mode)	V <sub>DD</sub> -0.7	—	—	V	I <sub>OH</sub> = -1.3 mA, V <sub>DD</sub> = 4.5V, $-40^{\circ}\text{C}$ to $+85^{\circ}\text{C}$	
			V <sub>DD</sub> -0.7	—	—	V	I <sub>OH</sub> = -1.0 mA, V <sub>DD</sub> = 4.5V, $-40^{\circ}\text{C}$ to $+125^{\circ}\text{C}$	
D150*	V <sub>OD</sub>	<b>Open-Drain High Voltage</b>	—	—	8.5	V	RA4 pin	
<b>Capacitive Loading Specs on Output Pins</b>								
D100	C <sub>OSC2</sub>	OSC2/CLKOUT pin	—	—	15	pF	In XT, HS and LP modes when external clock is used to drive OSC1.	
D101	C <sub>IO</sub>	All I/O pins and OSC2 (in RC mode)	—	—	50	pF		

\* These parameters are characterized but not tested.

† Data in "Typ" column is at 5V, 25°C unless otherwise stated. These parameters are for design guidance only and are not tested.

- Note 1:** In RC Oscillator mode, the OSC1/CLKIN pin is a Schmitt Trigger input. It is not recommended that the PIC<sup>®</sup> be driven with external clock in RC mode.
- 2:** The leakage current on the MCLR/V<sub>PP</sub> pin is strongly dependent on the applied voltage level. The specified levels represent normal operating conditions. Higher leakage current may be measured at different input voltages.
- 3:** Negative current is defined as current sourced by the pin.

## 12.5 AC (Timing) Characteristics

### 12.5.1 TIMING PARAMETER SYMBOLOGY

The timing parameter symbols have been created using one of the following formats:

1. TppS2ppS
2. TppS

<b>T</b>	F      Frequency	T      Time
----------	------------------	-------------

Lowercase letters (pp) and their meanings:

<b>pp</b>	cc      CCP1	osc      OSC1
	ck      CLKOUT	rd $\overline{RD}$
	cs $\overline{CS}$	rw $\overline{RD}$ or $\overline{WR}$
	di      SDI	sc      SCK
	do      SDO	ss $\overline{SS}$
	dt      Data in	t0      T0CKI
	io      I/O port	t1      T1CKI
	mc $\overline{MCLR}$	wr $\overline{WR}$

Uppercase letters and their meanings:

<b>S</b>	F      Fall	P      Period
	H      High	R      Rise
	I      Invalid (High-impedance)	V      Valid
	L      Low	Z      High-impedance

# PIC16F716

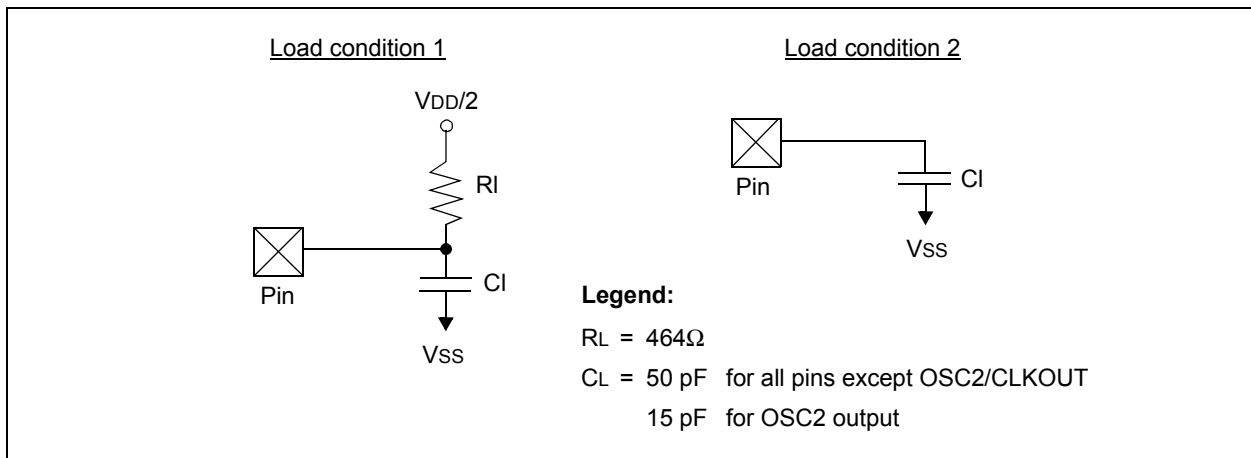
## 12.5.2 TIMING CONDITIONS

The temperature and voltages specified in Table 12-1 apply to all timing specifications, unless otherwise noted. Figure 12-3 specifies the load conditions for the timing specifications.

**TABLE 12-1: TEMPERATURE AND VOLTAGE SPECIFICATIONS - AC**

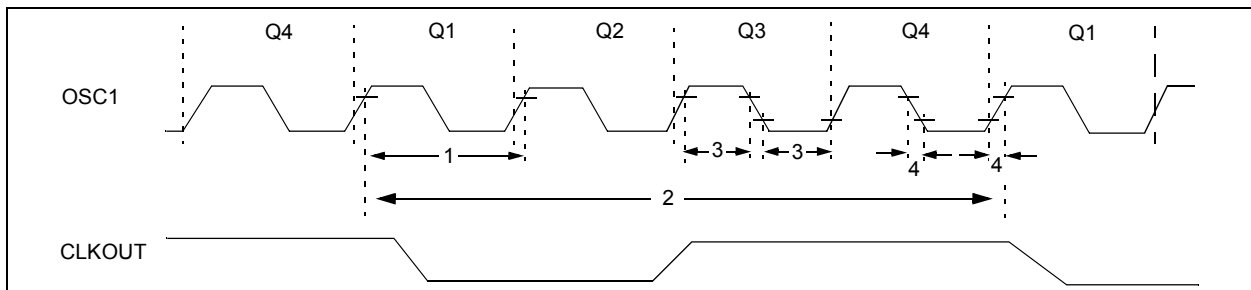
<b>AC CHARACTERISTICS</b>	<b>Standard Operating Conditions (unless otherwise stated)</b>
	Operating temperature $-40^{\circ}\text{C} \leq T_A \leq +85^{\circ}\text{C}$ for industrial $-40^{\circ}\text{C} \leq T_A \leq +125^{\circ}\text{C}$ for extended Operating voltage $V_{DD}$ range as described in DC spec <b>Section 12.1 “DC Characteristics: PIC16F716 (Industrial, Extended)”</b> and <b>Section 12.4 “DC Characteristics: PIC16F716 (Industrial, Extended)”</b> . LC parts operate for commercial/industrial temp's only.

**FIGURE 12-3: LOAD CONDITIONS FOR DEVICE TIMING SPECIFICATIONS**



## 12.5.3 TIMING DIAGRAMS AND SPECIFICATIONS

**FIGURE 12-4: EXTERNAL CLOCK TIMING**



**TABLE 12-2: EXTERNAL CLOCK TIMING REQUIREMENTS**

Param No.	Sym	Characteristic	Min	Typ†	Max	Units	Conditions
1A	Fosc	Ext. Clock Input Frequency <sup>(1)</sup>	DC	—	4	MHz	RC and XT Osc modes
			DC	—	20	MHz	HS Osc mode
			DC	—	200	kHz	LP Osc mode
		Oscillator Frequency <sup>(1)</sup>	DC	—	4	MHz	RC Osc mode
			0.1	—	4	MHz	XT Osc mode
			4	—	20	MHz	HS Osc mode
5	—		200	kHz	LP Osc mode		
1	Tosc	External CLKIN Period <sup>(1)</sup>	250	—	—	ns	RC and XT Osc modes
			50	—	—	ns	HS Osc mode
			5	—	—	μs	LP Osc mode
		Oscillator Period <sup>(1)</sup>	250	—	—	ns	RC Osc mode
			250	—	10,000	ns	XT Osc mode
			50	—	250	ns	HS Osc mode
5	—		—	μs	LP Osc mode		
2	Tcy	Instruction Cycle Time <sup>(1)</sup>	200	—	DC	ns	T <sub>cy</sub> = 4/F <sub>osc</sub>
3*	TosL, TosH	External Clock in (OSC1) High or Low Time	100	—	—	ns	XT oscillator
			2.5	—	—	μs	LP oscillator
			15	—	—	ns	HS oscillator
4*	TosR, TosF	External Clock in (OSC1) Rise or Fall Time	—	—	25	ns	XT oscillator
			—	—	50	ns	LP oscillator
			—	—	15	ns	HS oscillator

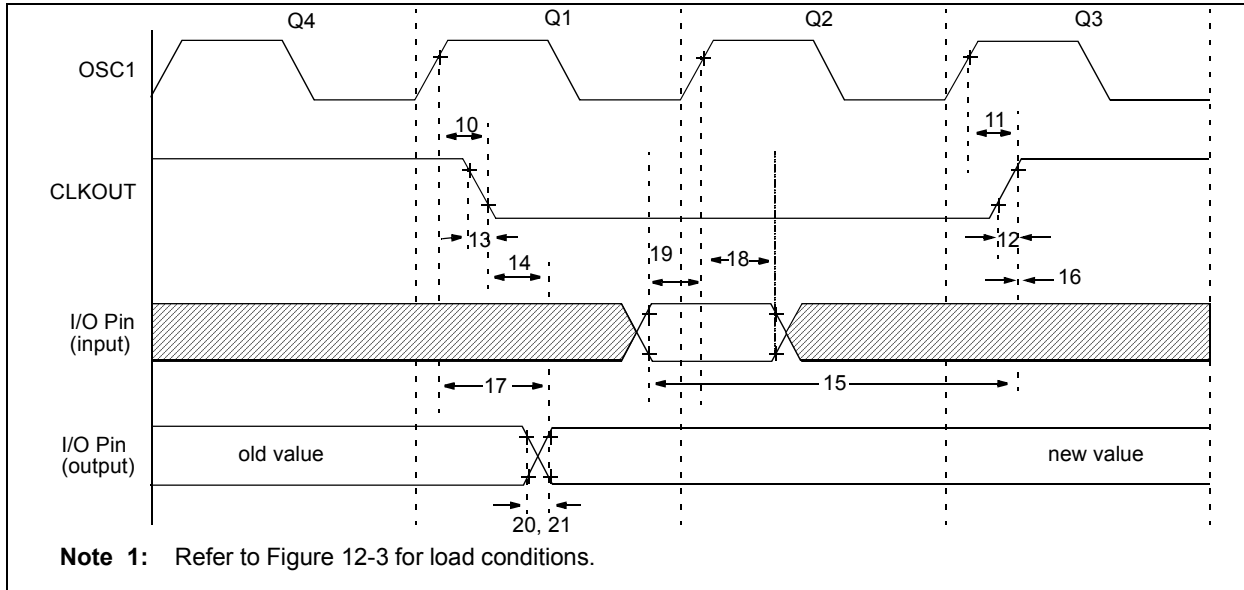
\* These parameters are characterized but not tested.

† Data in “Typ” column is at 5V, 25°C unless otherwise stated. These parameters are for design guidance only and are not tested.

**Note 1:** Instruction cycle period (T<sub>cy</sub>) equals four times the input oscillator time base period. All specified values are based on characterization data for that particular oscillator type under standard operating conditions with the device executing code. Exceeding these specified limits may result in an unstable oscillator operation and/or higher than expected current consumption. All devices are tested to operate at “min” values with an external clock applied to the OSC1/CLKIN pin.  
When an external clock input is used, the “Max” cycle time limit is “DC” (no clock) for all devices.

# PIC16F716

**FIGURE 12-5: CLKOUT AND I/O TIMING**



**TABLE 12-3: CLKOUT AND I/O TIMING REQUIREMENTS**

Param No.	Sym	Characteristic	Min	Typ†	Max	Units	Conditions
10*	TosH2ckL	OSC1↑ to CLKOUT↓	—	75	200	ns	(Note 1)
11*	TosH2ckH	OSC1↑ to CLKOUT↑	—	75	200	ns	(Note 1)
12*	TckR	CLKOUT rise time	—	35	100	ns	(Note 1)
13*	TckF	CLKOUT fall time	—	35	100	ns	(Note 1)
14*	TckL2ioV	CLKOUT ↓ to Port out valid	—	—	20	ns	(Note 1)
15*	TioV2ckH	Port input valid before CLKOUT ↑	Tosc + 200	—	—	ns	(Note 1)
16*	TckH2ioI	Port input hold after CLKOUT ↑	0	—	—	ns	(Note 1)
17*	TosH2ioV	OSC1↑ (Q1 cycle) to Port out valid	—	50	150	ns	
18*	TosH2ioI	OSC1↑ (Q2 cycle) to Port input invalid (I/O in hold time)	Standard	100	—	ns	
18A*			Extended (LC)	200	—	ns	
19*	TioV2osH	Port input valid to OSC1↑ (I/O in setup time)	0	—	—	ns	
20*	TioR	Port output rise time	Standard	10	40	ns	
20A*			Extended (LC)	—	80	ns	
21*	TioF	Port output fall time	Standard	10	40	ns	
21A*			Extended (LC)	—	80	ns	
22††*	TINP	INT pin high or low time	Tcy	—	—	ns	
23††*	TRBP	RB<7:4> change INT high or low time	Tcy	—	—	ns	

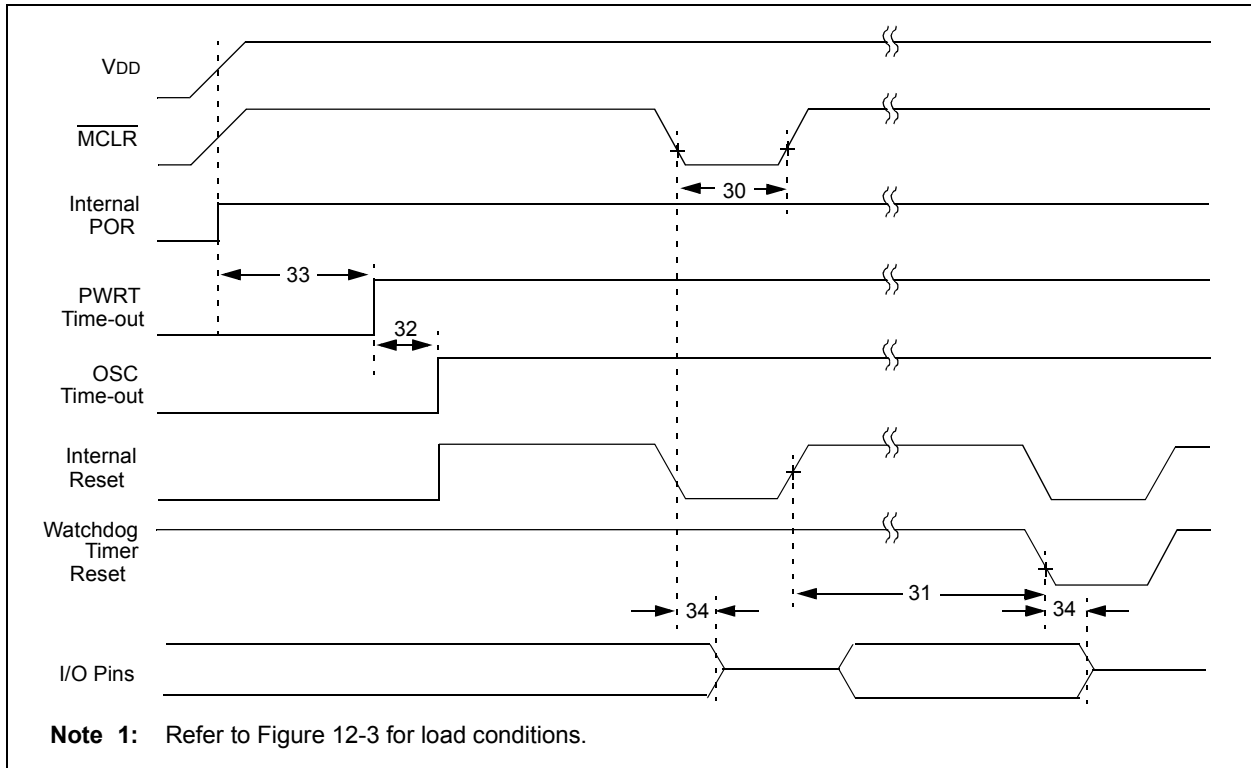
\* These parameters are characterized but not tested.

† Data in "Typ" column is at 5V, 25°C unless otherwise stated. These parameters are for design guidance only and are not tested.

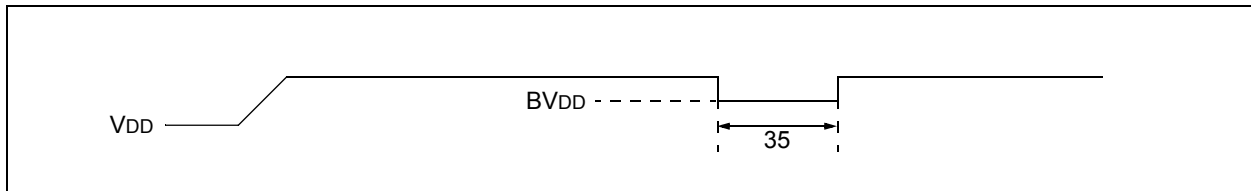
†† These parameters are asynchronous events not related to any internal clock edge.

**Note 1:** Measurements are taken in RC mode where CLKOUT output is 4 x Tosc.

**FIGURE 12-6: RESET, WATCHDOG TIMER, OSCILLATOR START-UP TIMER AND POWER-UP TIMER TIMING<sup>(1)</sup>**



**FIGURE 12-7: BROWN-OUT RESET TIMING**



**TABLE 12-4: RESET, WATCHDOG TIMER, OSCILLATOR START-UP TIMER, POWER-UP TIMER, AND BROWN-OUT RESET REQUIREMENTS**

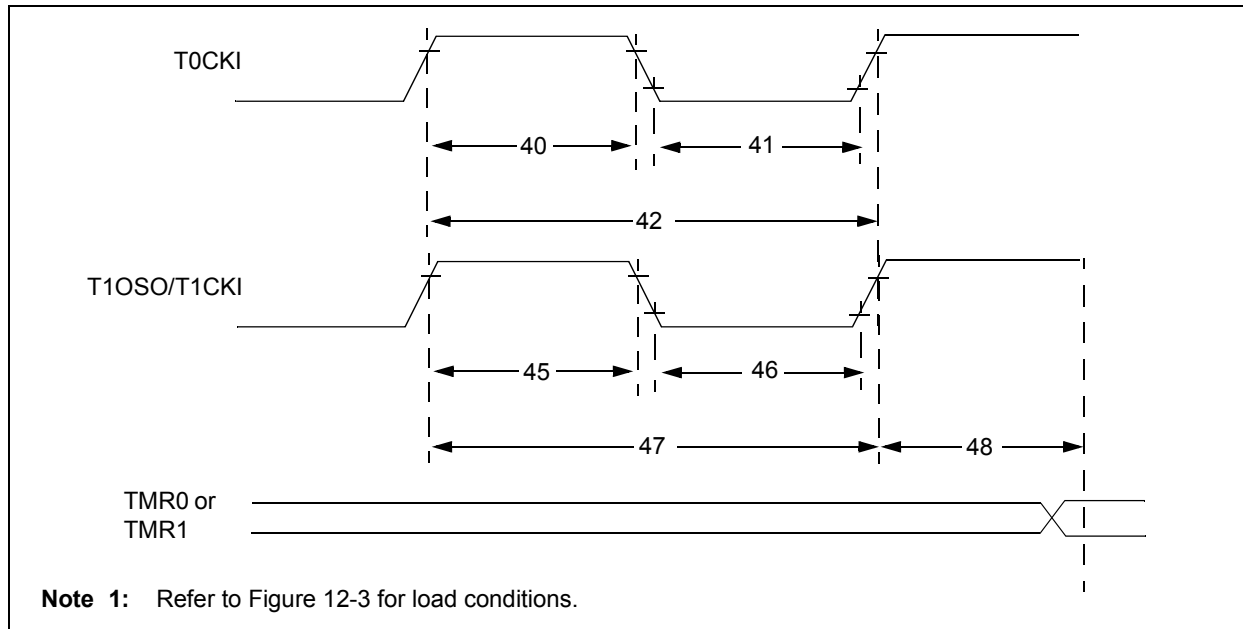
Param No.	Sym	Characteristic	Min	Typ†	Max	Units	Conditions
30	T <sub>MCLR</sub>	MCLR Pulse Width (low)	2	—	—	μs	V <sub>DD</sub> = 5V, -40°C to +125°C
31*	T <sub>WDT</sub>	Watchdog Timer Time-out Period (No Prescaler)	7	18	33	ms	V <sub>DD</sub> = 5V, -40°C to +85°C
			TBD	TBD	TBD	ms	V <sub>DD</sub> = 5V, +85°C to +125°C
32	T <sub>OSt</sub>	Oscillation Start-up Timer Period	—	1024 T <sub>OSC</sub>	—	—	T <sub>OSC</sub> = OSC1 period
33*	T <sub>PWRT</sub>	Power-up Timer Period	28	72	132	ms	V <sub>DD</sub> = 5V, -40°C to +85°C
			TBD	TBD	TBD	ms	V <sub>DD</sub> = 5V, +85°C to +125°C
34	T <sub>IOZ</sub>	I/O high-impedance from MCLR Low or WDT Reset	—	—	2.1	μs	
35	T <sub>BOR</sub>	Brown-out Reset Pulse Width	100	—	—	μs	V <sub>DD</sub> ≤ BV <sub>DD</sub> (D005)

\* These parameters are characterized but not tested.

† Data in "Typ" column is at 5V, 25°C unless otherwise stated. These parameters are for design guidance only and are not tested.

# PIC16F716

**FIGURE 12-8: TIMER0 AND TIMER1 EXTERNAL CLOCK TIMINGS<sup>(1)</sup>**



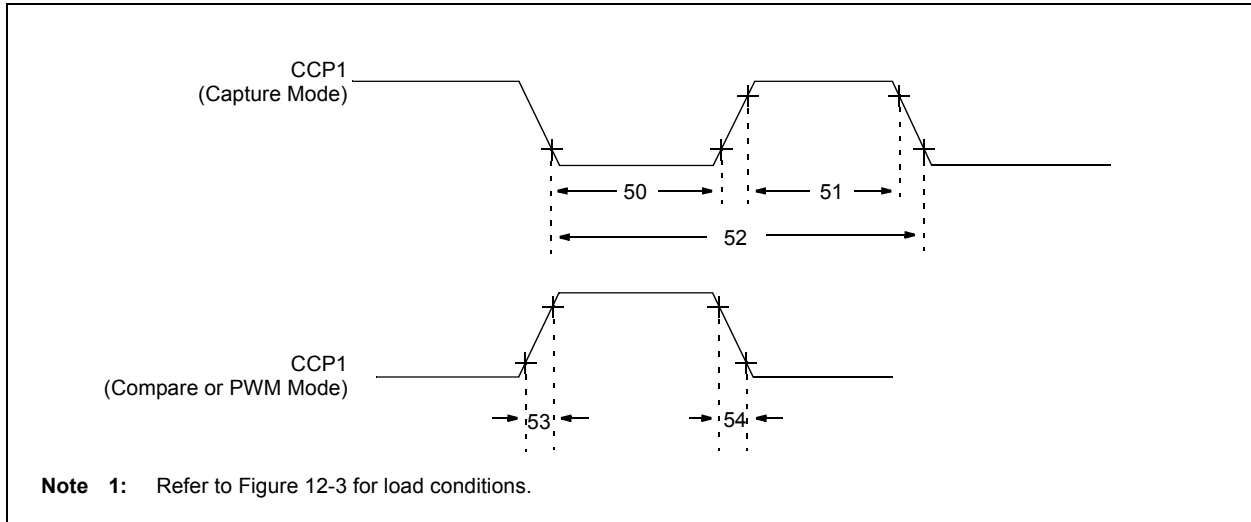
**TABLE 12-5: TIMER0 AND TIMER1 EXTERNAL CLOCK REQUIREMENTS**

Param No.	Sym	Characteristic		Min	Typ†	Max	Units	Conditions	
40*	Tt0H	T0CKI High Pulse Width	No Prescaler	$0.5T_{CY} + 20$	—	—	ns	Must also meet parameter 42	
			With Prescaler	10	—	—	ns		
41*	Tt0L	T0CKI Low Pulse Width	No Prescaler	$0.5T_{CY} + 20$	—	—	ns	Must also meet parameter 42	
			With Prescaler	10	—	—	ns		
42*	Tt0P	T0CKI Period	No Prescaler	$T_{CY} + 40$	—	—	ns	N = prescale value (2, 4, ..., 256)	
			With Prescaler	Greater of: $20$ or $T_{CY} + 40$ N	—	—	ns		
45*	Tt1H	T1CKI High Time	Synchronous, Prescaler = 1	$0.5T_{CY} + 20$	—	—	ns	Must also meet parameter 47	
			Synchronous, Prescaler = 2,4,8	Standard	15	—	—		ns
			Asynchronous	Standard	30	—	—		ns
46*	Tt1L	T1CKI Low Time	Synchronous, Prescaler = 1	$0.5T_{CY} + 20$	—	—	ns	Must also meet parameter 47	
			Synchronous, Prescaler = 2,4,8	Standard	15	—	—		ns
			Asynchronous	Standard	30	—	—		ns
47*	Tt1P	T1CKI input period	Synchronous	Standard	Greater of: $30$ OR $T_{CY} + 40$ N	—	—	ns	N = prescale value (1, 2, 4, 8)
			Asynchronous	Standard	60	—	—	ns	
	Ft1	Timer1 oscillator input frequency range (oscillator enabled by setting bit T1OSCEN)		32.768	—	32.768	kHz		
48*	TCKEZtmr1	Delay from external clock edge to timer increment		$2T_{osc}$	—	$7T_{osc}$	—		

\* These parameters are characterized but not tested.

† Data in "Typ" column is at 5V, 25°C unless otherwise stated. These parameters are for design guidance only and are not tested.

**FIGURE 12-9: CAPTURE/COMPARE/PWM TIMINGS<sup>(1)</sup>**



**TABLE 12-6: CAPTURE/COMPARE/PWM REQUIREMENTS**

Param No.	Sym	Characteristic		Min	Typ†	Max	Units	Conditions
50*	TccL	CCP1 input low time	No Prescaler	$0.5T_{CY} + 20$	—	—	ns	
			With Prescaler   Standard	10	—	—	ns	
51*	TccH	CCP1 input high time	No Prescaler	$0.5T_{CY} + 20$	—	—	ns	
			With Prescaler   Standard	10	—	—	ns	
52*	TccP	CCP1 input period		$\frac{3T_{CY} + 40}{N}$	—	—	ns	N = prescale value (1, 4, or 16)
53*	TccR	CCP1 output rise time	Standard	—	10	40	ns	
53A*			Extended	—	—	80	ns	
54*	TccF	CCP1 output fall time	Standard	—	10	40	ns	
54A*			Extended	—	—	80	ns	

\* These parameters are characterized but not tested.

† Data in "Typ" column is at 5V, 25°C unless otherwise stated. These parameters are for design guidance only and are not tested.

# PIC16F716

**TABLE 12-7: A/D CONVERTER CHARACTERISTICS: PIC16F716 (INDUSTRIAL, EXTENDED)**

Param No.	Sym	Characteristic	Min	Typ†	Max	Units	Conditions
A00	VDD	VDD Operation	2.5	—	5.5	V	
A01	NR	Resolution	—	—	8-bits	bit	$V_{REF} = V_{DD} = 5.12V$ , $V_{SS} \leq V_{AIN} \leq V_{REF}$
A02	EABS	Total Absolute error	—	—	$< \pm 1$	LSb	$V_{REF} = V_{DD} = 5.12V$ , $V_{SS} \leq V_{AIN} \leq V_{REF}$
A03	EIL	Integral linearity error	—	—	$< \pm 1$	LSb	$V_{REF} = V_{DD} = 5.12V$ , $V_{SS} \leq V_{AIN} \leq V_{REF}$
A04	EDL	Differential linearity error	—	—	$< \pm 1$	LSb	$V_{REF} = V_{DD} = 5.12V$ , $V_{SS} \leq V_{AIN} \leq V_{REF}$
A05	EFS	Full scale error	—	—	$< \pm 1$	LSb	$V_{REF} = V_{DD} = 5.12V$ , $V_{SS} \leq V_{AIN} \leq V_{REF}$
A06	E0FF	Offset error	—	—	$< \pm 1$	LSb	$V_{REF} = V_{DD} = 5.12V$ , $V_{SS} \leq V_{AIN} \leq V_{REF}$
A10	—	Monotonicity	—	guaranteed <sup>(3)</sup>	—	—	$V_{SS} \leq V_{AIN} \leq V_{REF}$
A20	VREF	Reference voltage	2.5V	—	$V_{DD} + 0.3$	V	
A25	VAIN	Analog input voltage	$V_{SS} - 0.3$	—	$V_{REF} + 0.3$	V	
A30	ZAIN	Recommended impedance of analog voltage source	—	—	10.0	k $\Omega$	
A40	IAD	A/D conversion current (VDD)	Standard	180	—	$\mu A$	Average current consumption when A/D is on. <sup>(1)</sup>
A50	IREF	VREF input current <sup>(2)</sup>	10	—	1000	$\mu A$	During VAIN acquisition. Based on differential of V <sub>HOLD</sub> to VAIN to charge CHOLD, see <b>Section 12.1 “DC Characteristics: PIC16F716 (Industrial, Extended)”</b> . During A/D Conversion cycle
			—	—	10	$\mu A$	

\* These parameters are characterized but not tested.

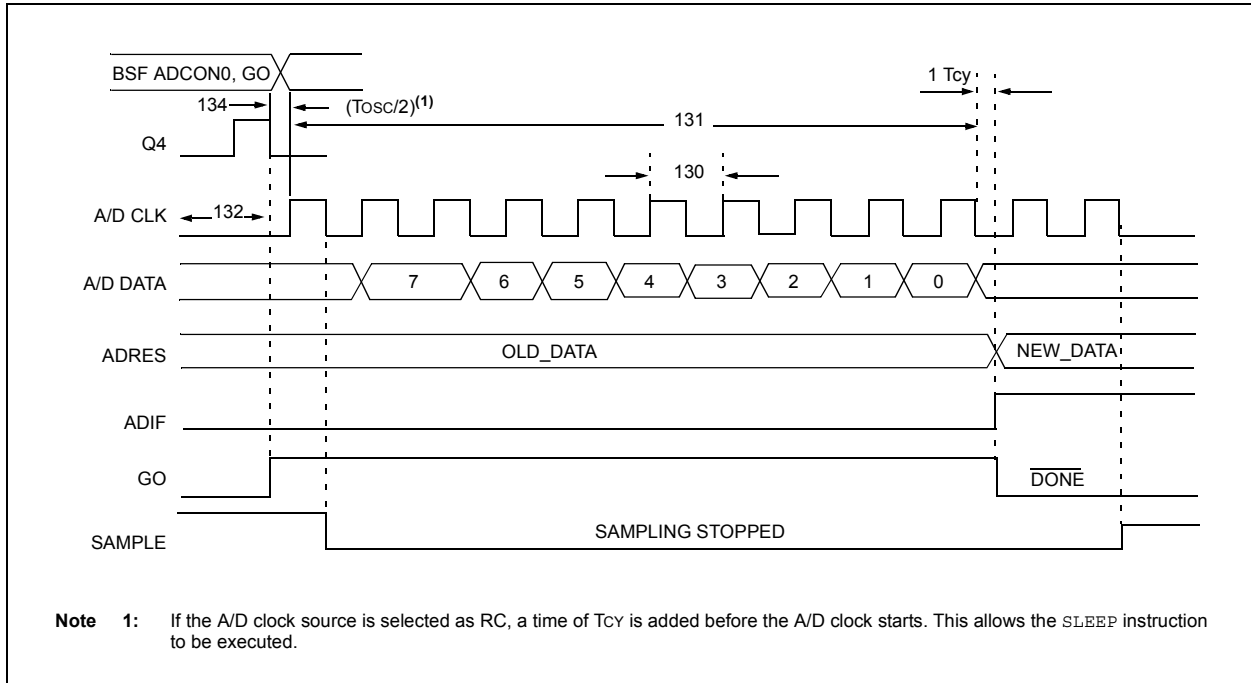
† Data in “Typ” column is at 5V, 25°C unless otherwise stated. These parameters are for design guidance only and are not tested.

**Note 1:** When A/D is off, it will not consume any current other than minor leakage current. The power-down current spec includes any such leakage from the A/D module.

**2:** VREF current is from RA3 pin or VDD pin, whichever is selected as reference input.

**3:** The A/D conversion result never decreases with an increase in the input voltage, and has no missing codes.

**FIGURE 12-10: A/D CONVERSION TIMING**



**TABLE 12-8: A/D CONVERSION REQUIREMENTS**

Param No.	Sym	Characteristic		Min	Typ†	Max	Units	Conditions
130	TAD	A/D clock period	Industrial	1.6	—	—	μs	TOSC based, $V_{REF} \geq 3.0V$
			Industrial	1.6	4.0	6.0	μs	A/D RC mode
			Extended	1.6	—	—	μs	TOSC based, $V_{REF} \geq 3.0V$
			Extended	1.6	6.0	9.0	μs	A/D RC mode
131	TCNV	Conversion time (not including S/H time) <sup>(1)</sup>	9.5	—	9.5	TAD		
132	TACQ	Acquisition time	(Note 2)	20	—	μs	The minimum time is the amplifier settling time. This may be used if the "new" input voltage has not changed by more than 1 LSB (i.e., 20.0 mV @ 5.12V) from the last sampled voltage (as stated on CHOLD).	
			5*	—	—	μs		
134	TGO	Q4 to A/D clock start	—	Tosc/2 **	—	—	If the A/D clock source is selected as RC, a time of $T_{CY}$ is added before the A/D clock starts. This allows the <code>SLEEP</code> instruction to be executed.	
135	Tswc	Switching from convert → sample time	1.5 **	—	—	TAD		

\* These parameters are characterized but not tested.

\*\* This specification ensured by design.

† Data in "Typ" column is at 5V, 25°C unless otherwise stated. These parameters are for design guidance only and are not tested.

**Note 1:** ADRES register may be read on the following  $T_{CY}$  cycle.

**Note 2:** See Section 12.1 "DC Characteristics: PIC16F716 (Industrial, Extended)" for min. conditions.

# PIC16F716

---

NOTES:

## 13.0 DC AND AC CHARACTERISTICS GRAPHS AND TABLES

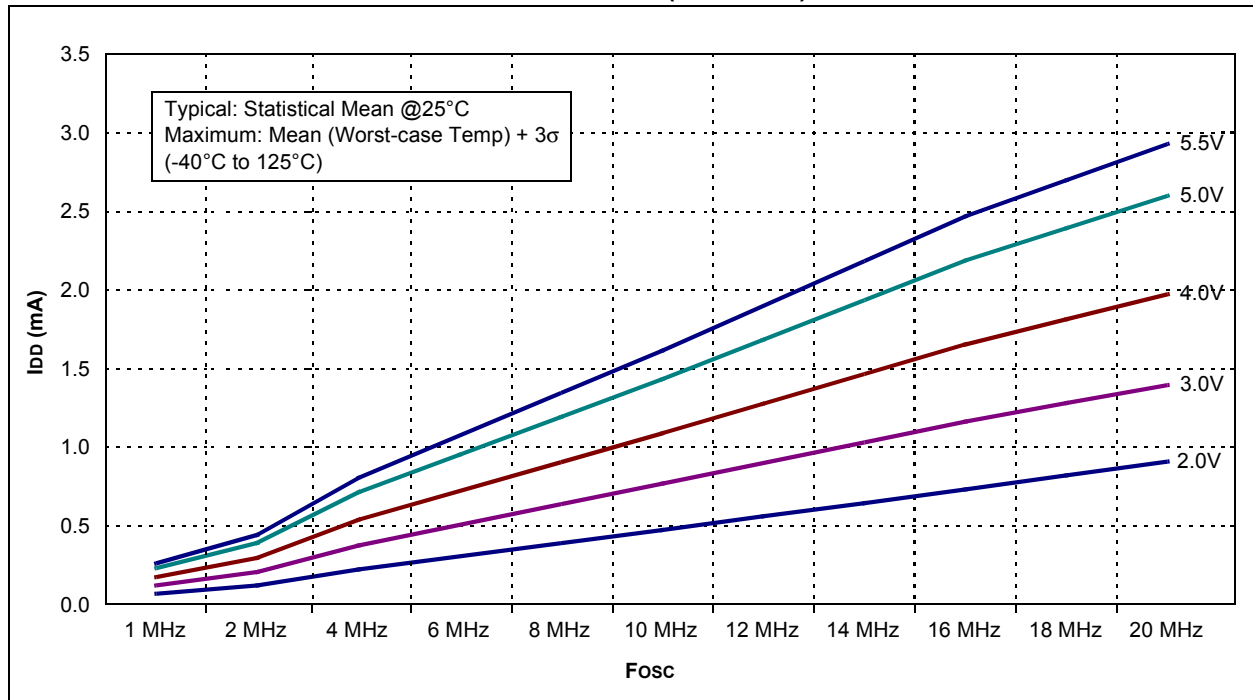
The graphs and tables provided in this section are for **design guidance** and are **not tested**.

In some graphs or tables, the data presented are **outside specified operating range** (i.e., outside specified  $V_{DD}$  range). This is for **information only** and devices are ensured to operate properly only within the specified range.

**Note:** The graphs and tables provided following this note are a statistical summary based on a limited number of samples and are provided for informational purposes only. The performance characteristics listed herein are not tested or guaranteed. In some graphs or tables, the data presented may be outside the specified operating range (e.g., outside specified power supply range) and therefore, outside the warranted range.

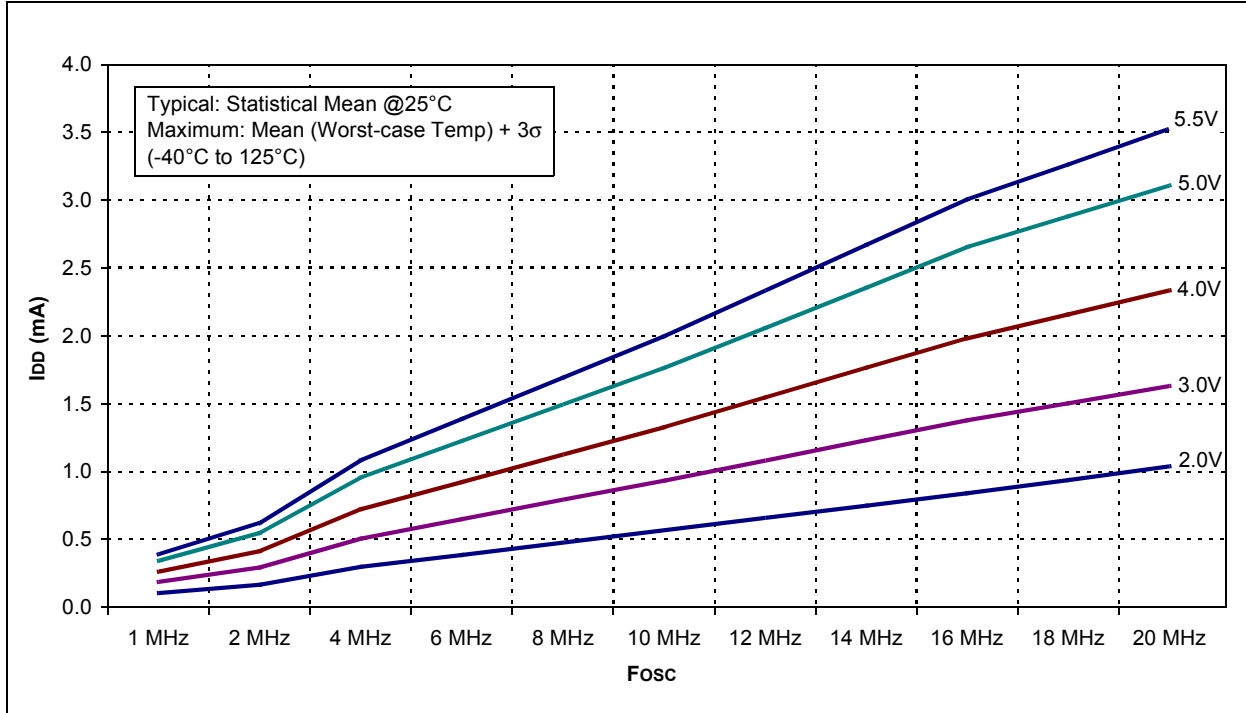
“Typical” represents the mean of the distribution at 25°C. “Maximum” or “minimum” represents (mean + 3 $\sigma$ ) or (mean - 3 $\sigma$ ) respectively, where  $\sigma$  is a standard deviation, over each temperature range.

**FIGURE 13-1: TYPICAL  $I_{DD}$  vs.  $F_{osc}$  OVER  $V_{DD}$  (EC MODE)**



# PIC16F716

**FIGURE 13-2: MAXIMUM  $I_{DD}$  vs.  $F_{osc}$  OVER  $V_{DD}$  (EC MODE)**



**FIGURE 13-3: TYPICAL  $I_{DD}$  vs.  $F_{osc}$  OVER  $V_{DD}$  (HS MODE)**

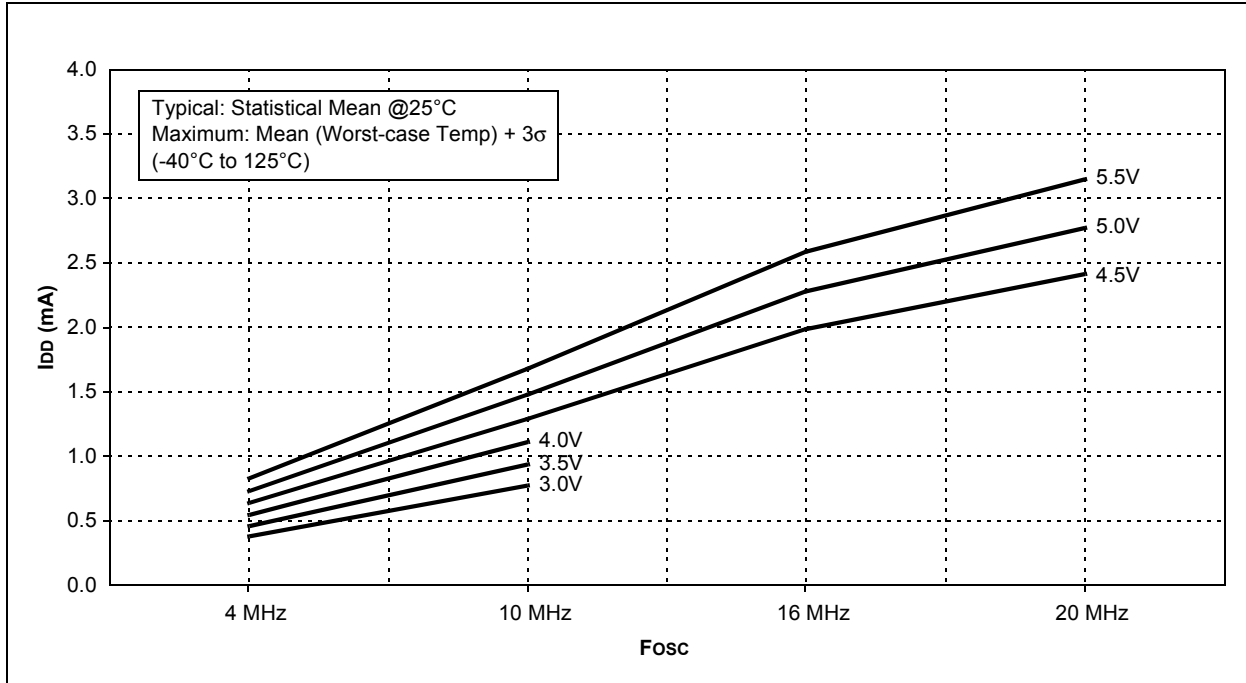


FIGURE 13-4: MAXIMUM I<sub>DD</sub> vs. F<sub>osc</sub> OVER V<sub>DD</sub> (HS MODE)

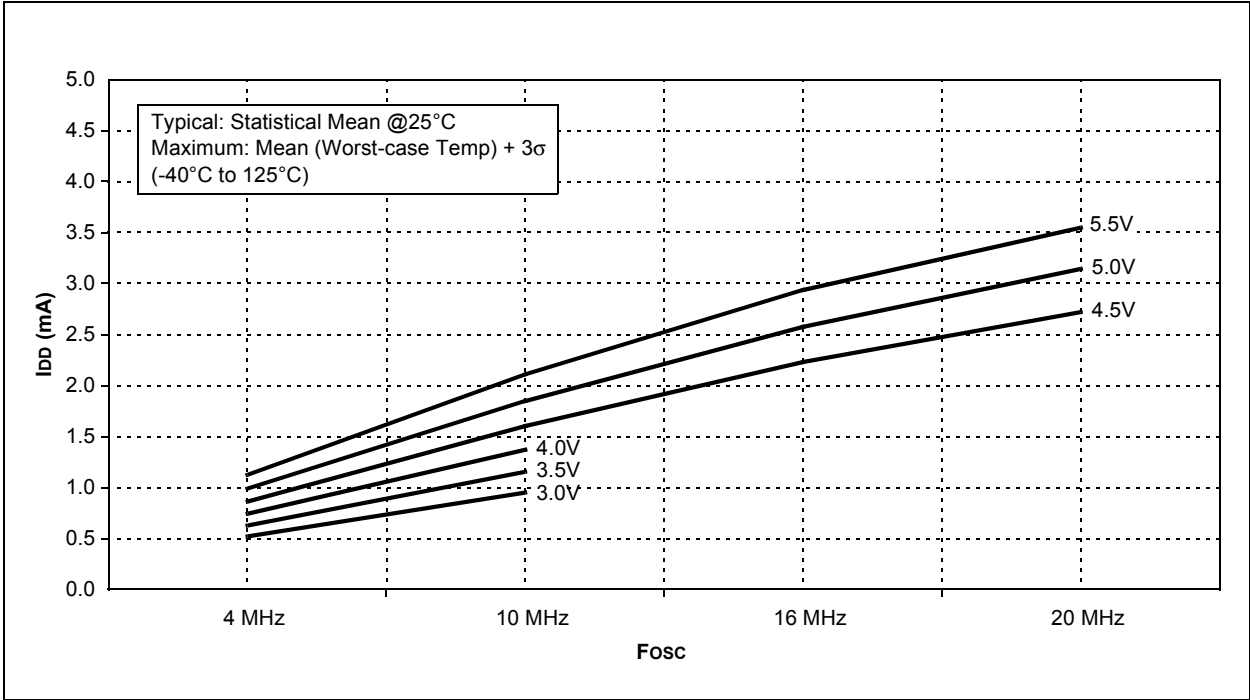
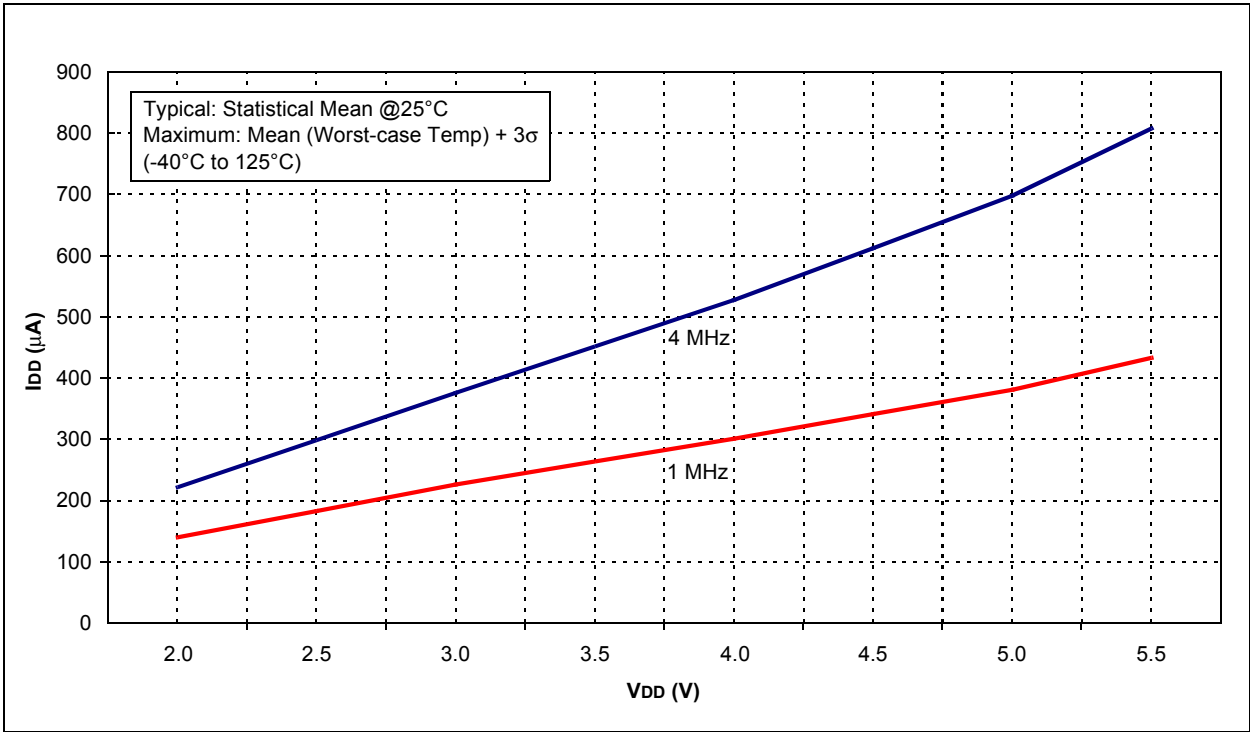


FIGURE 13-5: TYPICAL I<sub>DD</sub> vs. V<sub>DD</sub> OVER F<sub>osc</sub> (XT MODE)



# PIC16F716

FIGURE 13-6: MAXIMUM  $I_{DD}$  vs.  $V_{DD}$  OVER  $F_{osc}$  (XT MODE)

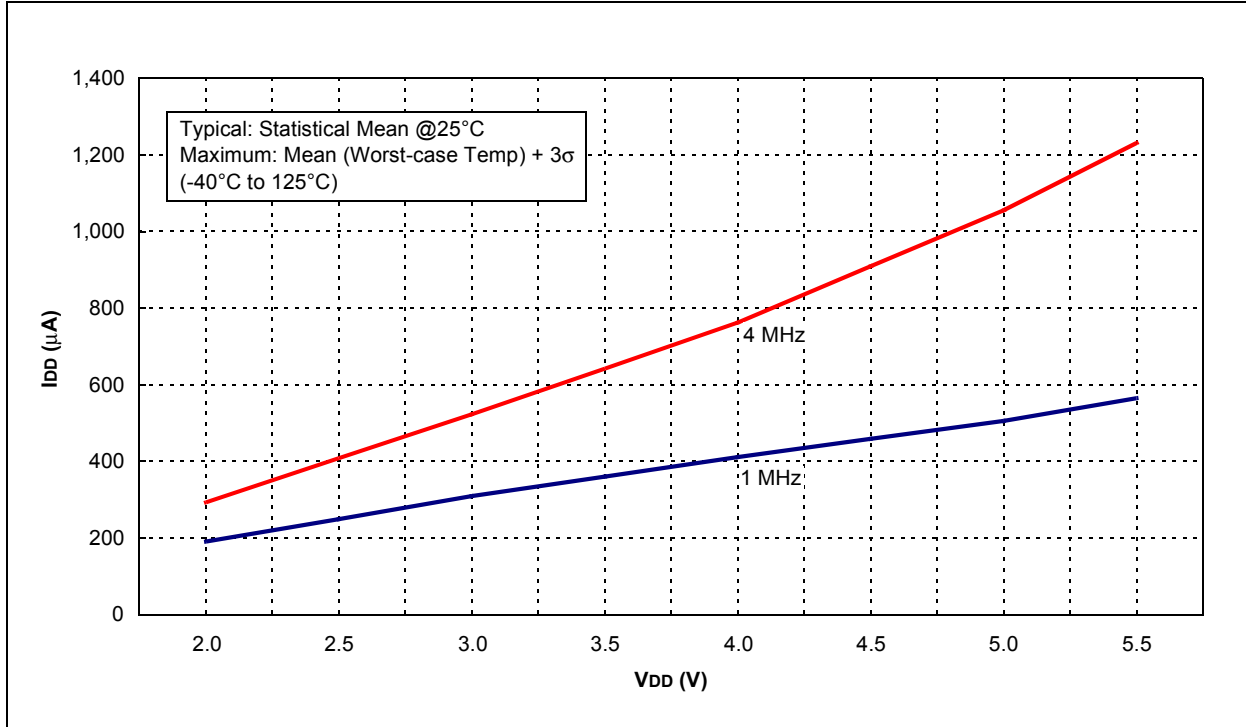
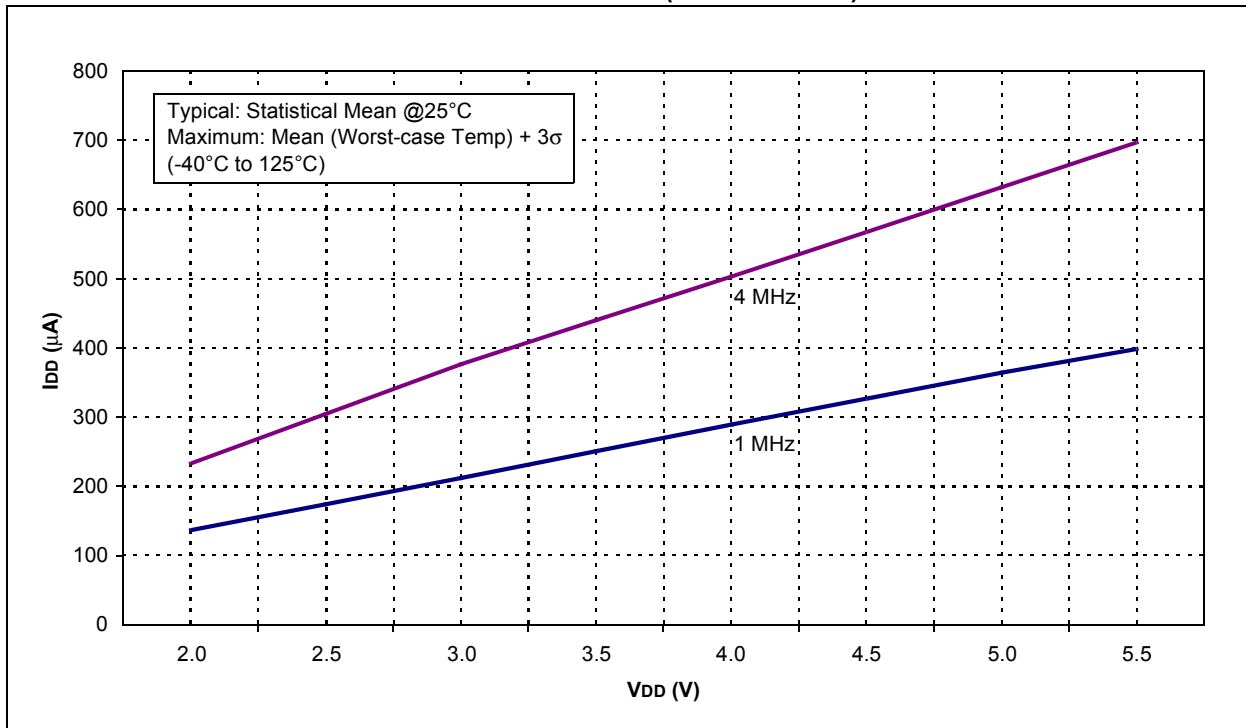
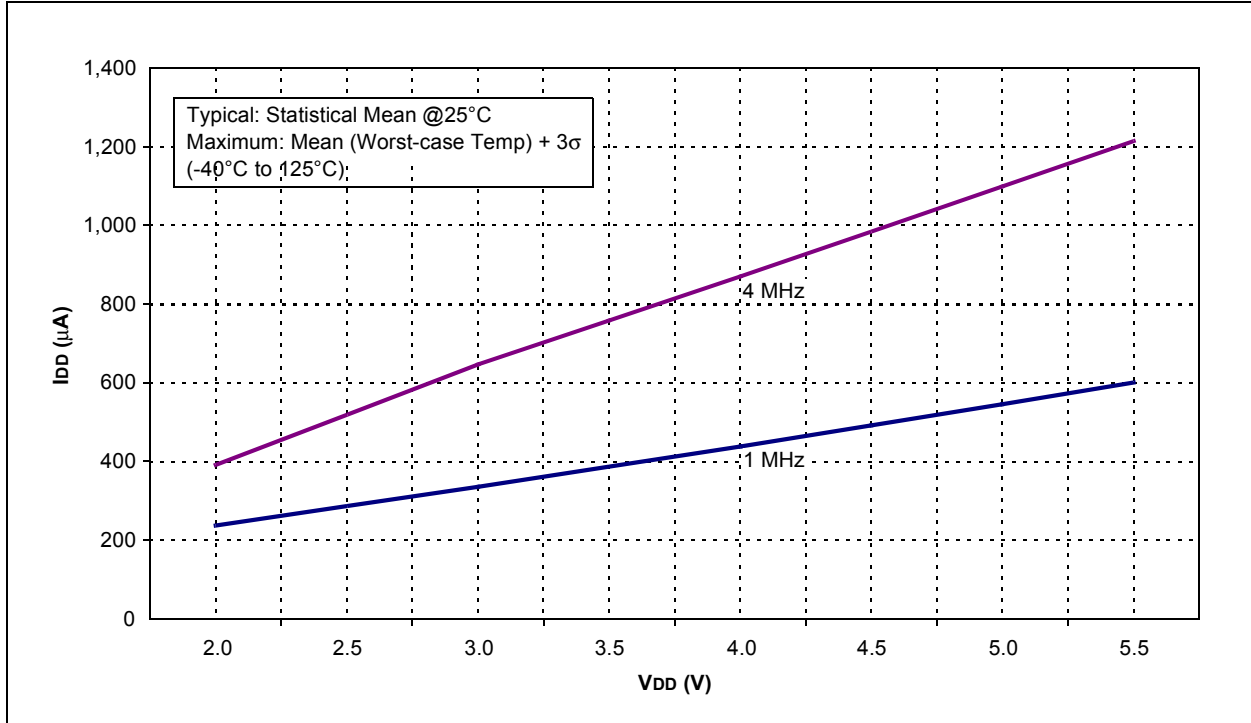


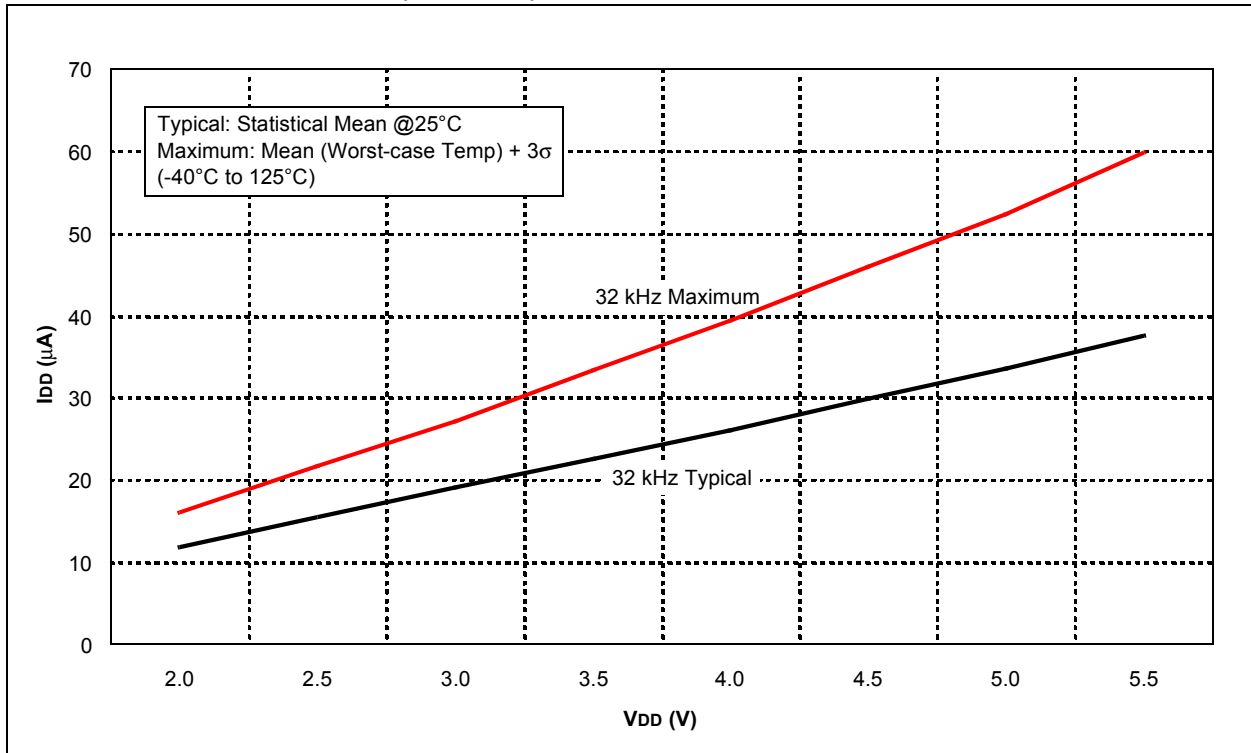
FIGURE 13-7: TYPICAL  $I_{DD}$  vs.  $V_{DD}$  OVER  $F_{osc}$  (EXTRC MODE)



**FIGURE 13-8: MAXIMUM I<sub>DD</sub> vs. V<sub>DD</sub> (EXTRC MODE)**



**FIGURE 13-9: I<sub>DD</sub> vs. V<sub>DD</sub> (LP MODE)**



# PIC16F716

FIGURE 13-10: TYPICAL  $I_{PD}$  vs.  $V_{DD}$  (SLEEP MODE, ALL PERIPHERALS DISABLED)

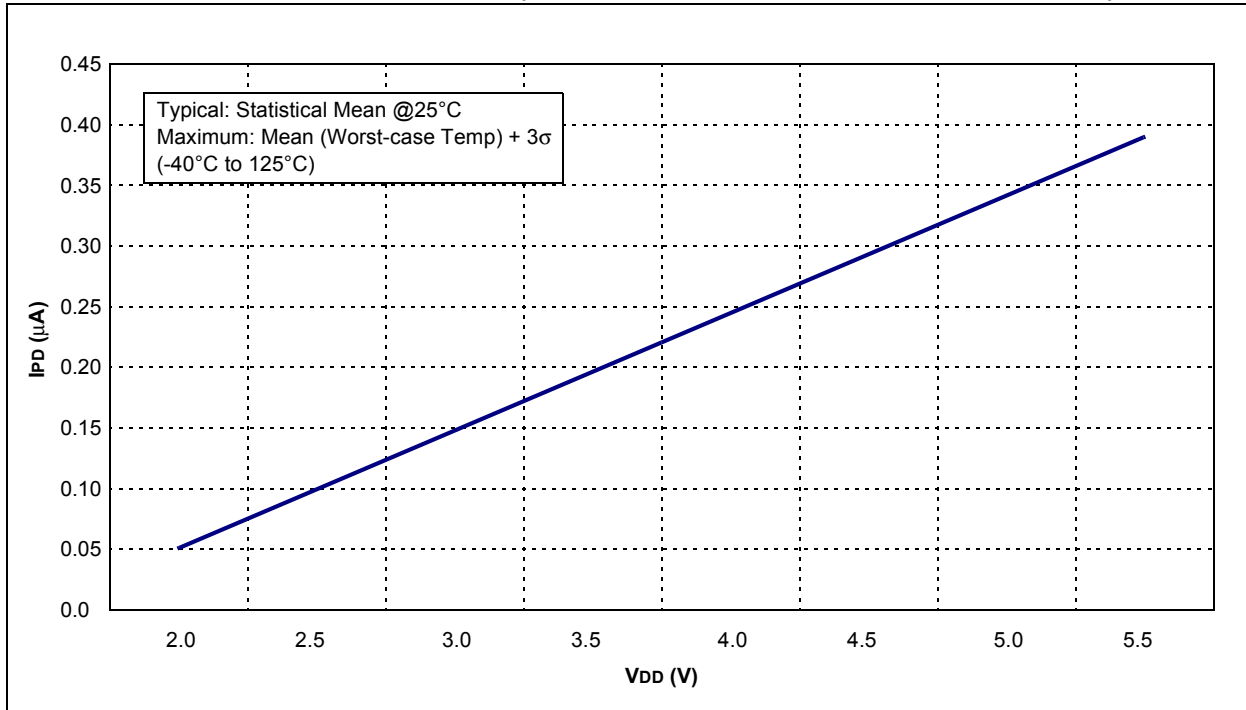
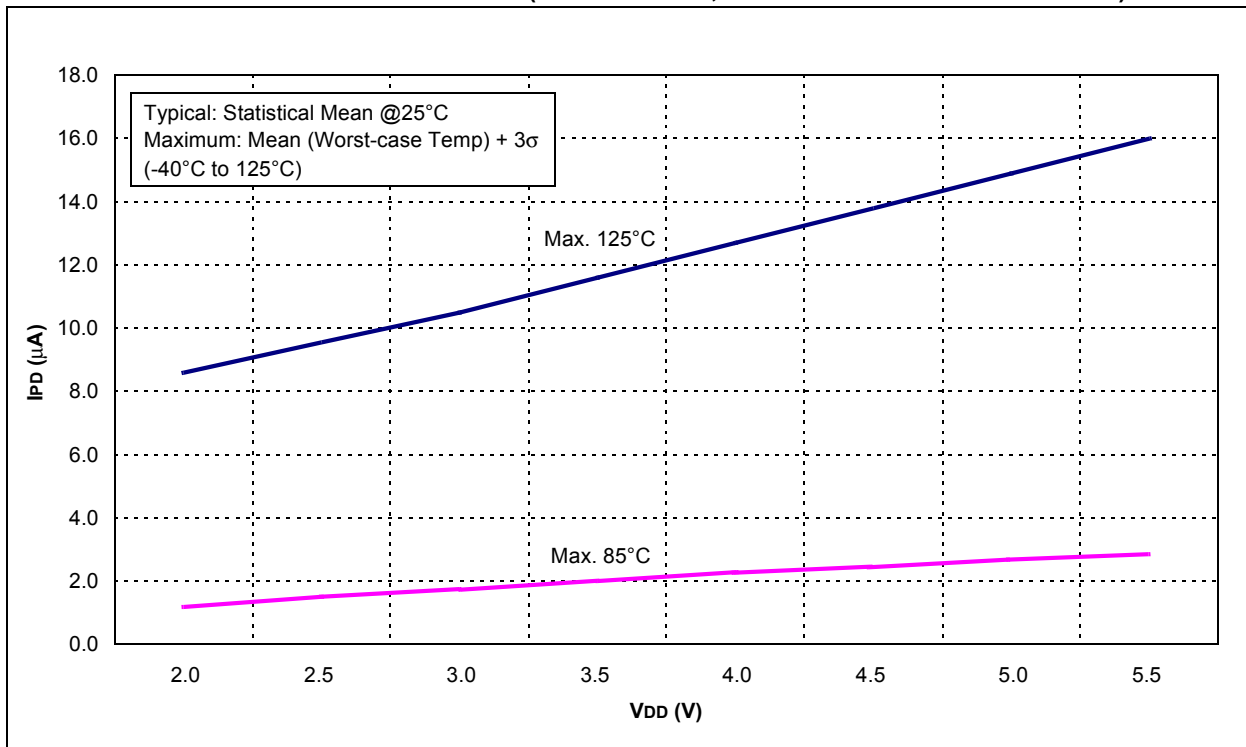
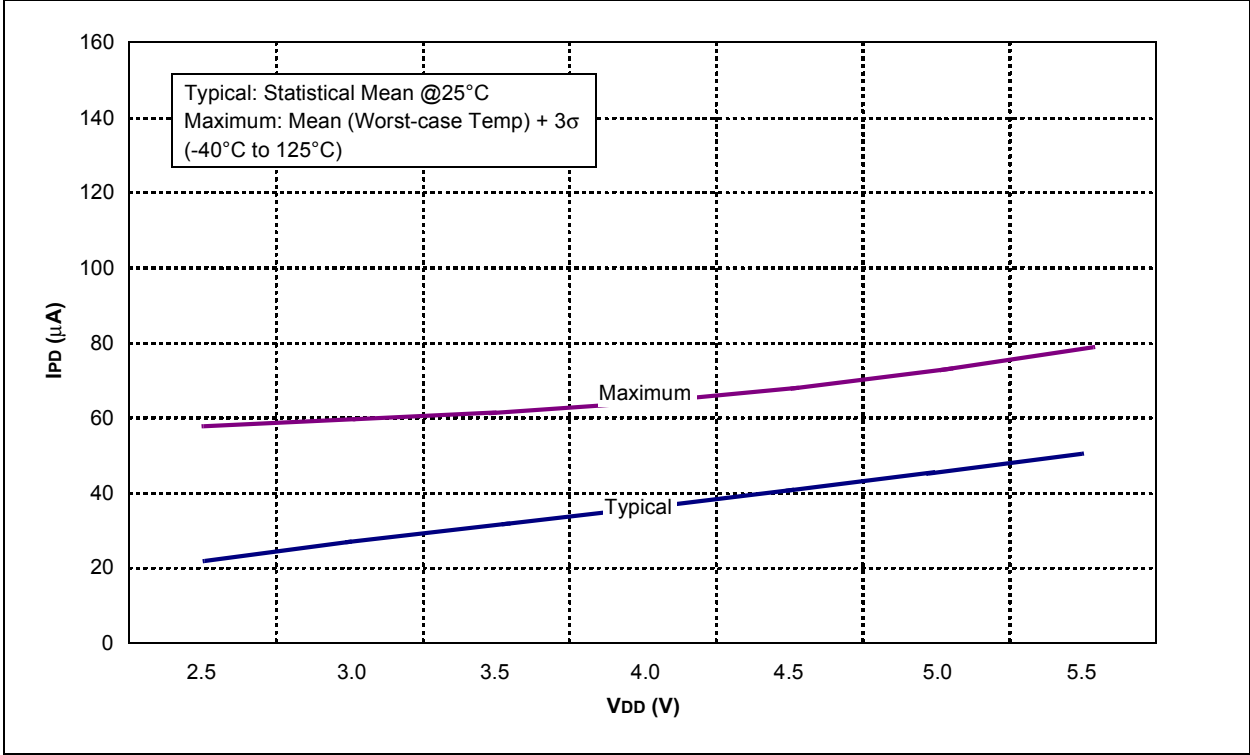


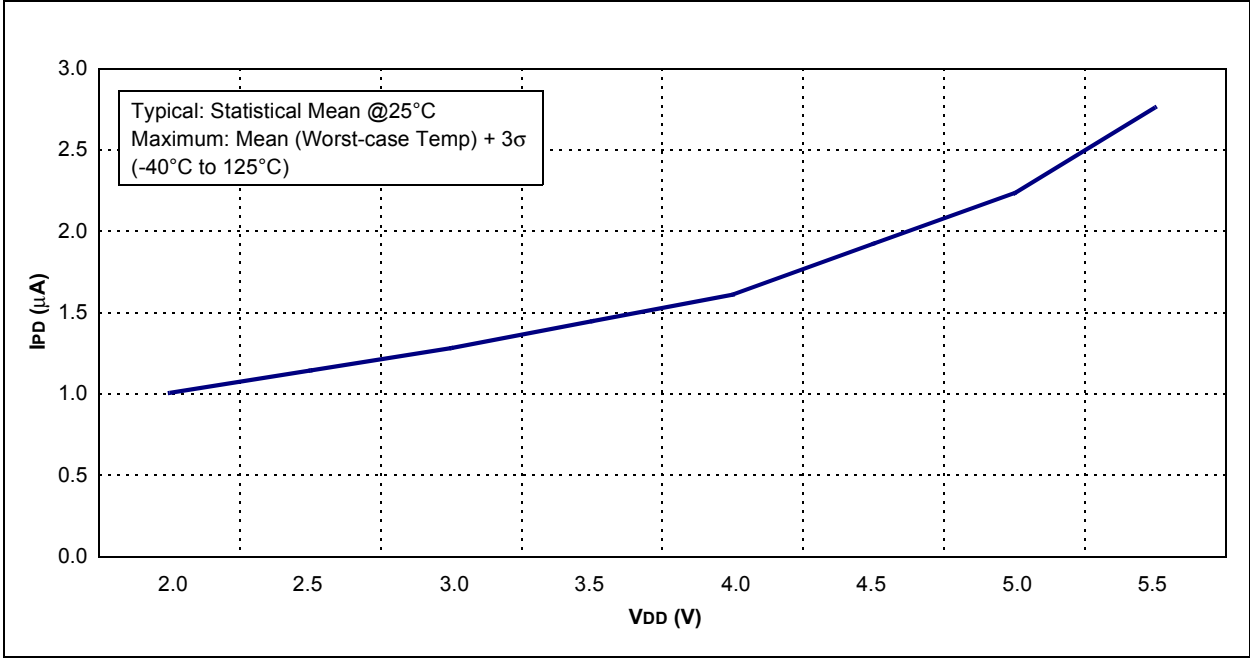
FIGURE 13-11: MAXIMUM  $I_{PD}$  vs.  $V_{DD}$  (SLEEP MODE, ALL PERIPHERALS DISABLED)



**FIGURE 13-12: BOR IPD vs. VDD OVER TEMPERATURE**

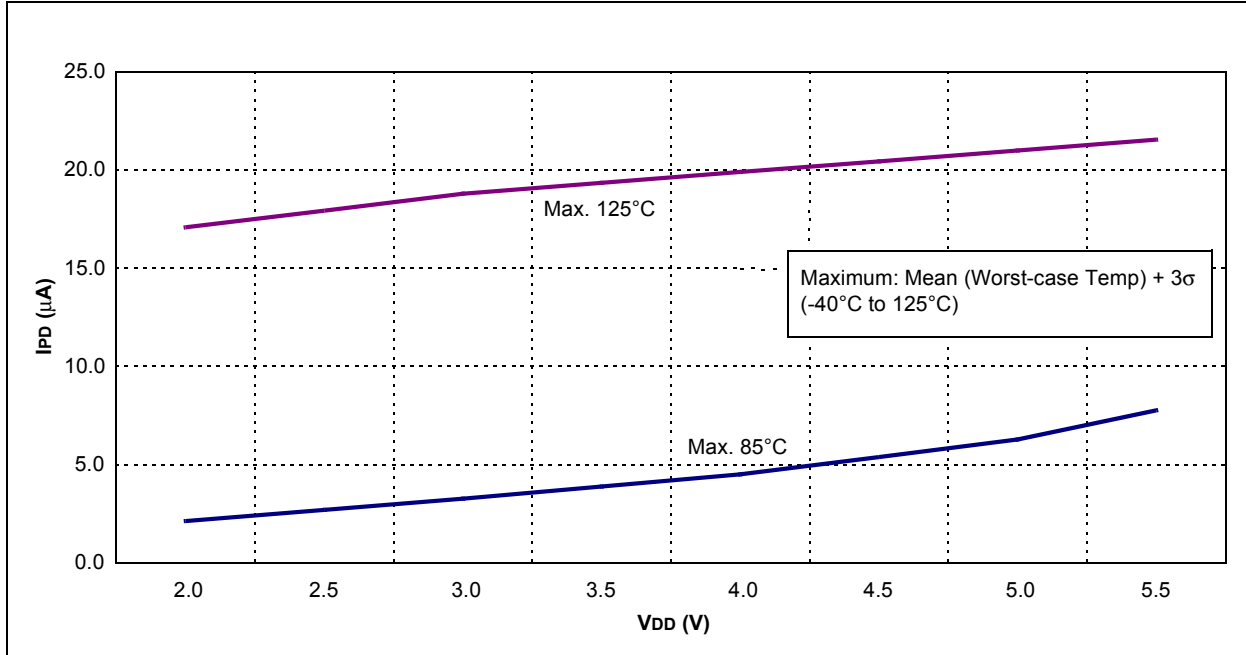


**FIGURE 13-13: TYPICAL WDT IPD vs. VDD OVER TEMPERATURE**



# PIC16F716

**FIGURE 13-14: MAXIMUM WDT IPD vs. VDD OVER TEMPERATURE**



**FIGURE 13-15: WDT PERIOD vs. VDD OVER TEMPERATURE**

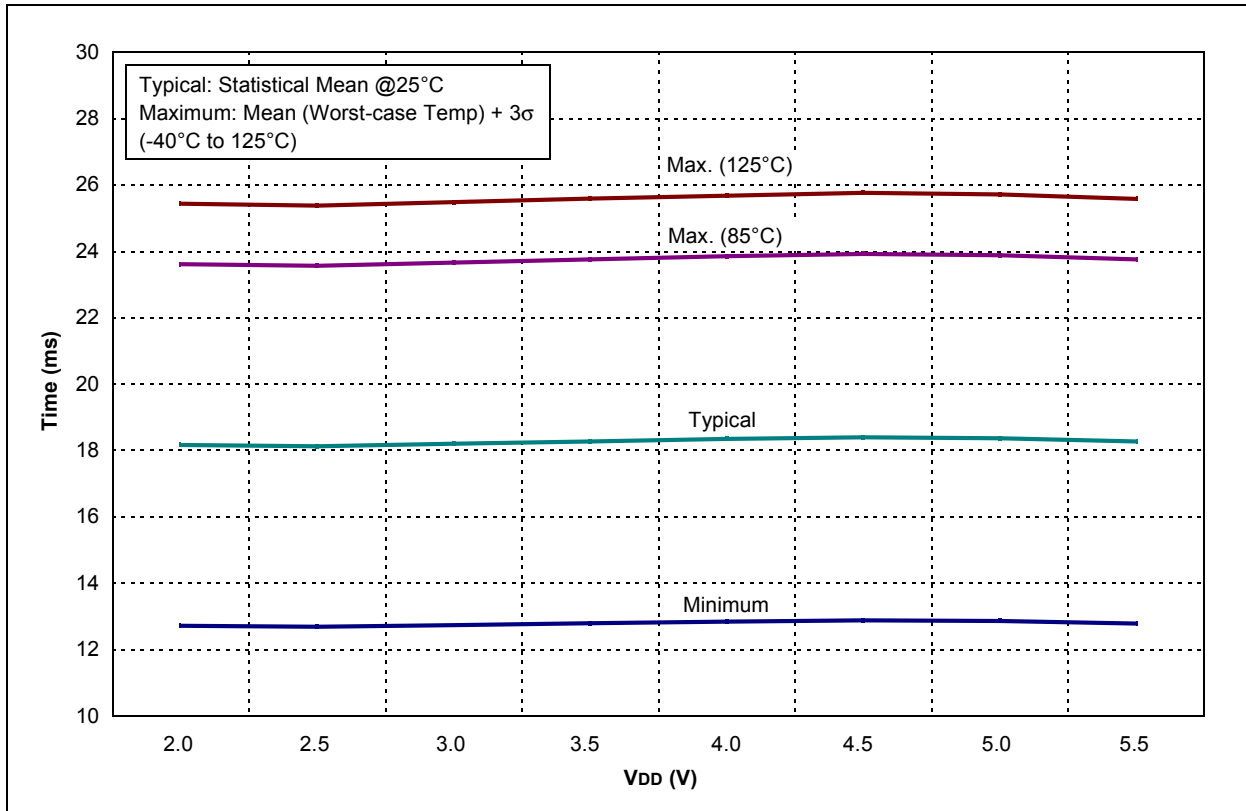
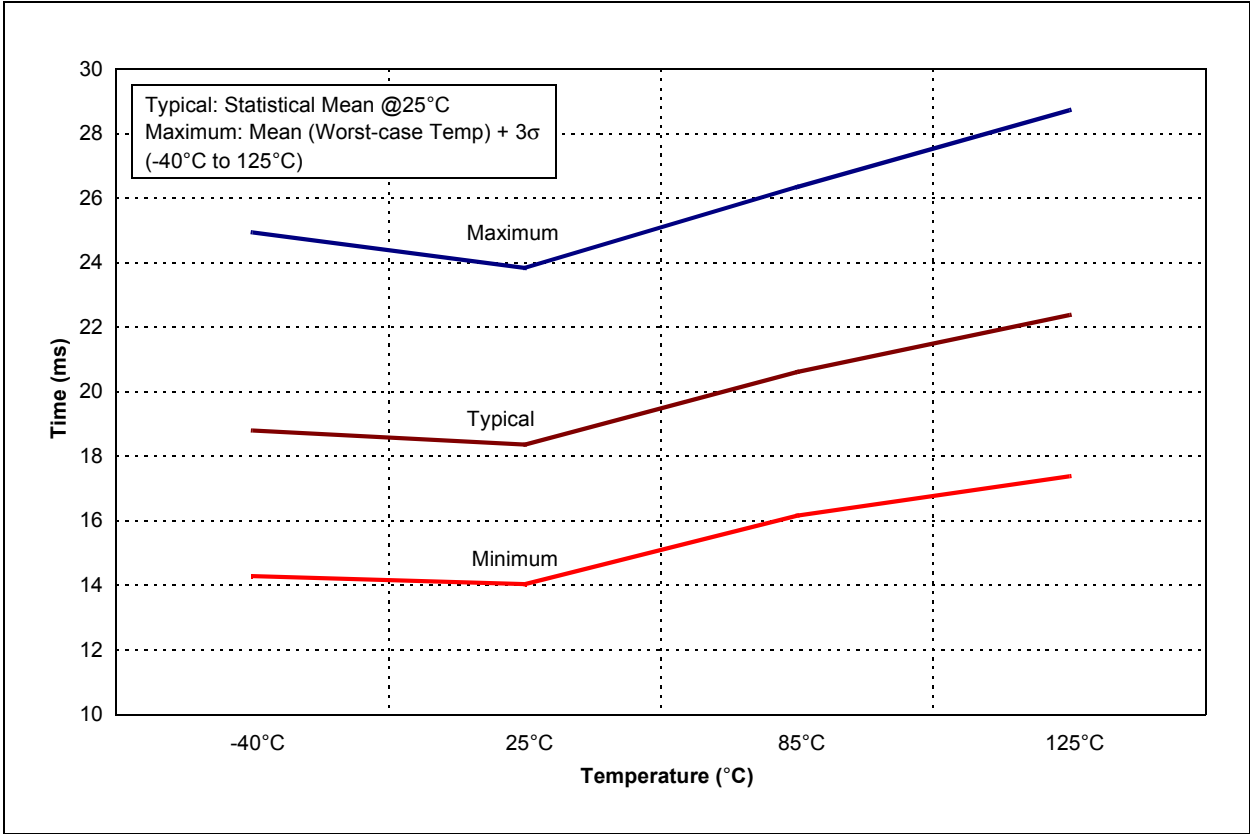
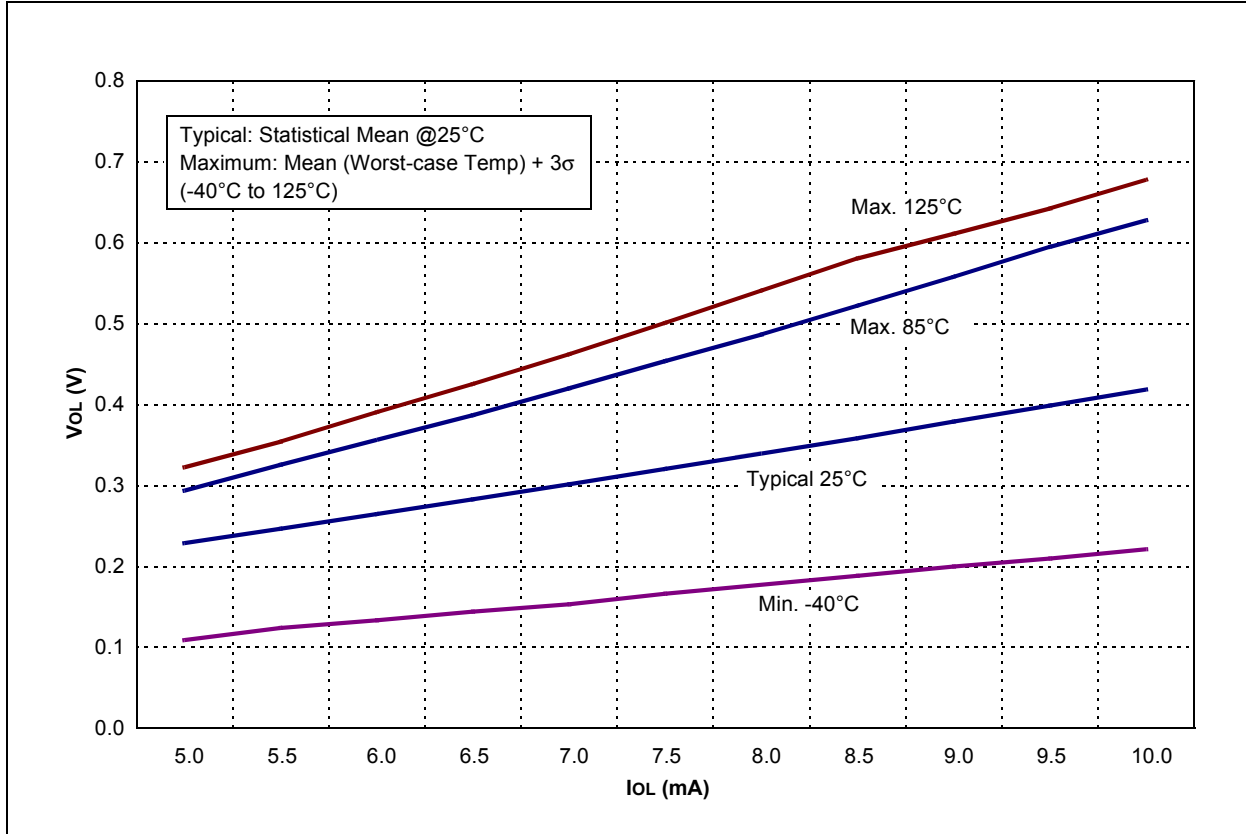


FIGURE 13-16: WDT PERIOD vs. TEMPERATURE OVER V<sub>DD</sub> (5.0V)

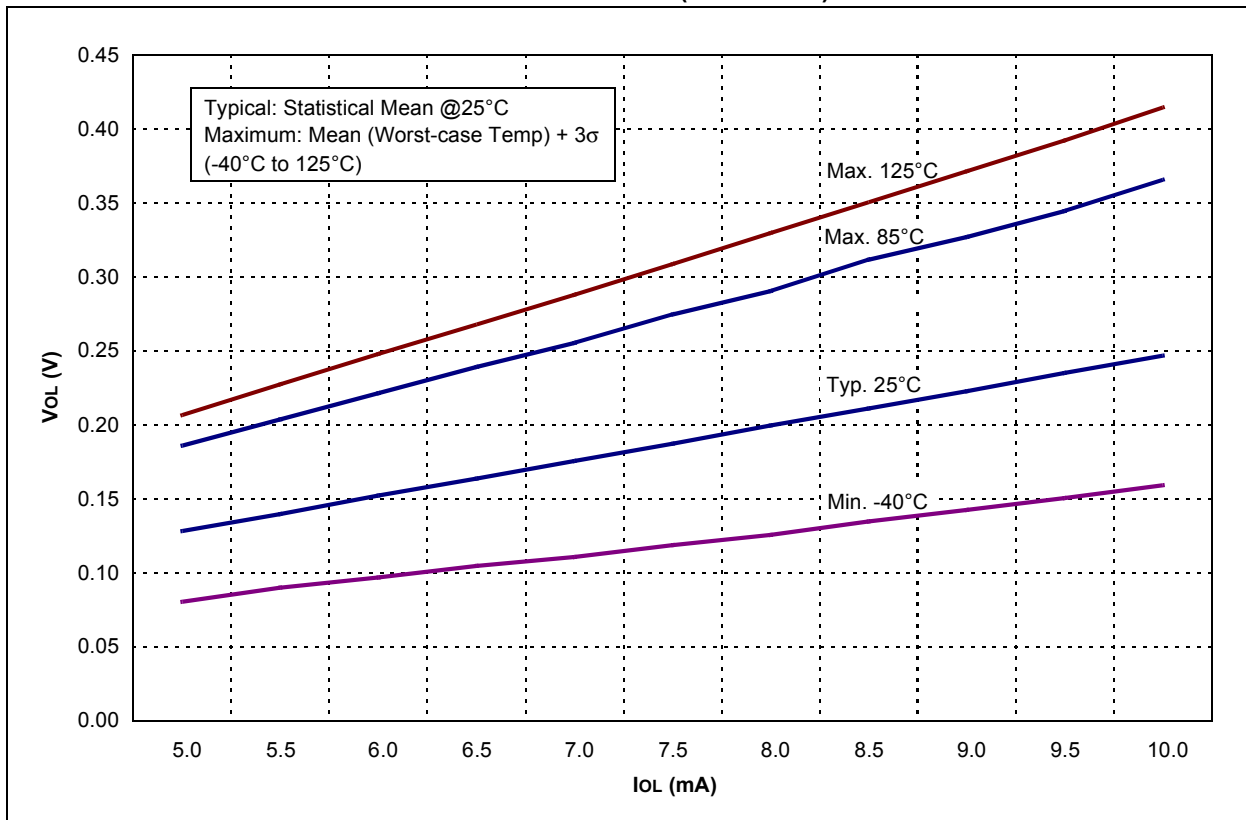


# PIC16F716

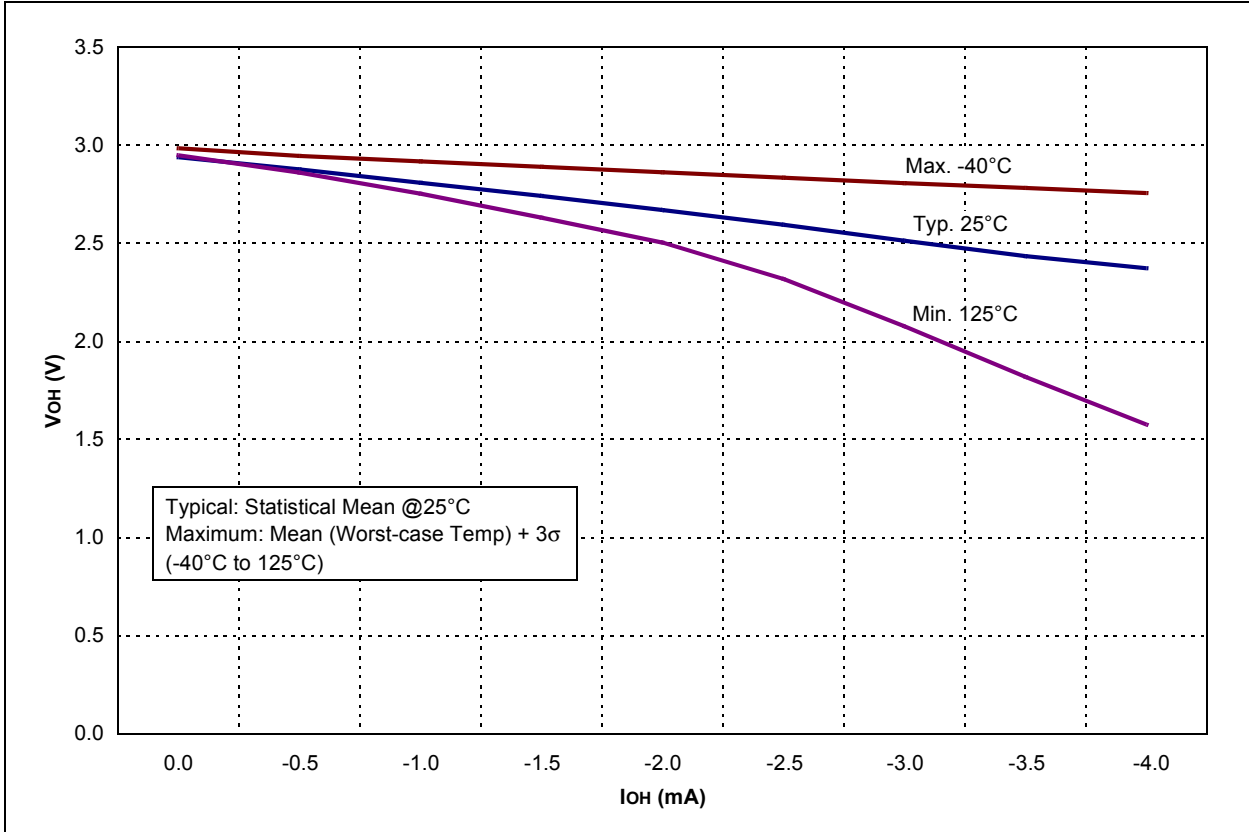
**FIGURE 13-17: VOL vs. IoL OVER TEMPERATURE (VDD = 3.0V)**



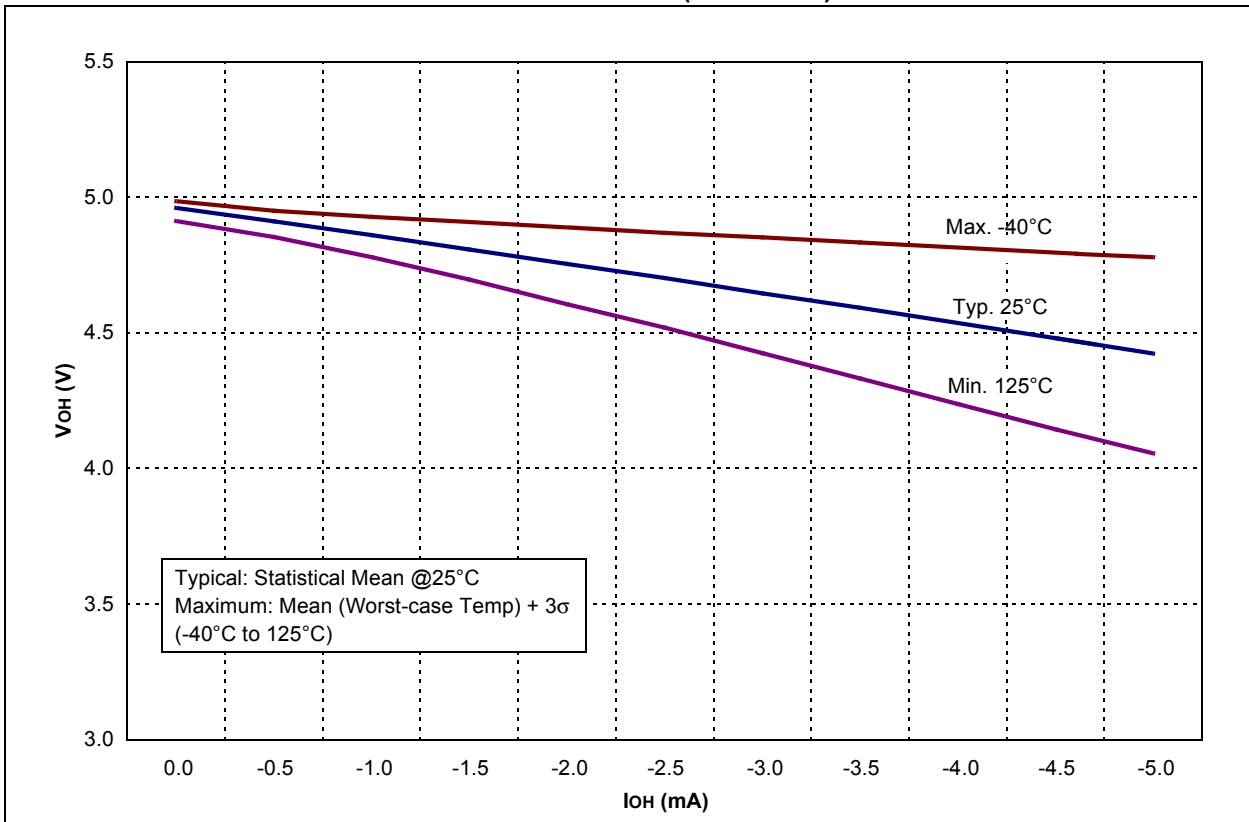
**FIGURE 13-18: VOL vs. IoL OVER TEMPERATURE (VDD = 5.0V)**



**FIGURE 13-19:  $V_{OH}$  vs.  $I_{OH}$  OVER TEMPERATURE ( $V_{DD} = 3.0V$ )**



**FIGURE 13-20:  $V_{OH}$  vs.  $I_{OH}$  OVER TEMPERATURE ( $V_{DD} = 5.0V$ )**



# PIC16F716

FIGURE 13-21: TTL INPUT THRESHOLD  $V_{IN}$  vs.  $V_{DD}$  OVER TEMPERATURE

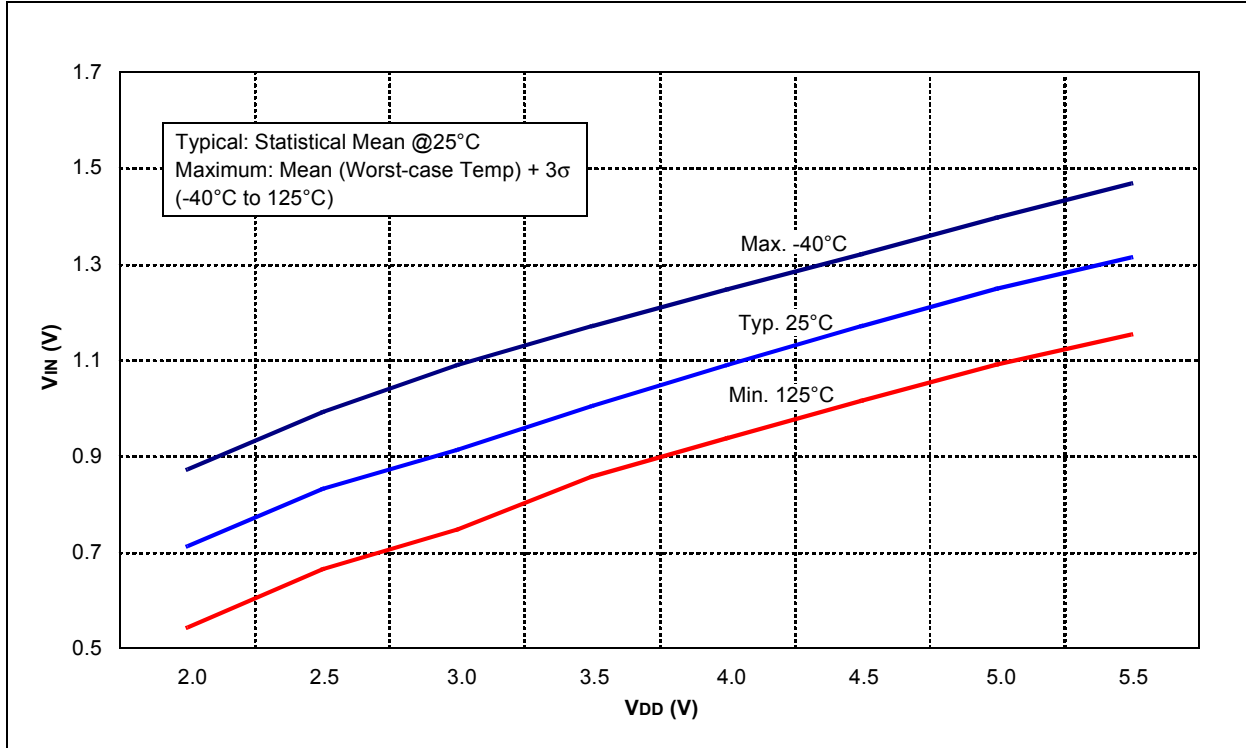


FIGURE 13-22: SCHMITT TRIGGER INPUT THRESHOLD  $V_{IN}$  vs.  $V_{DD}$  OVER TEMPERATURE

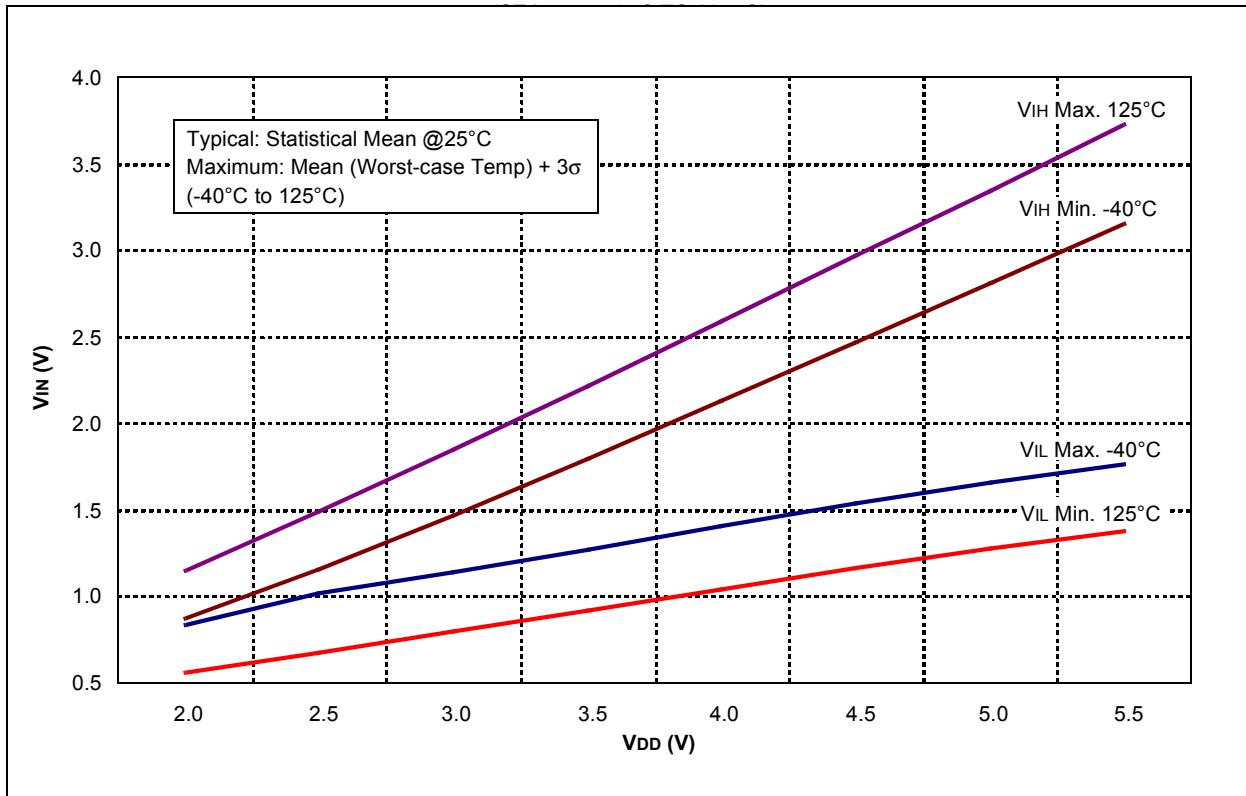


FIGURE 13-23: T1OSC IPD vs. VDD OVER TEMPERATURE (32 kHz)

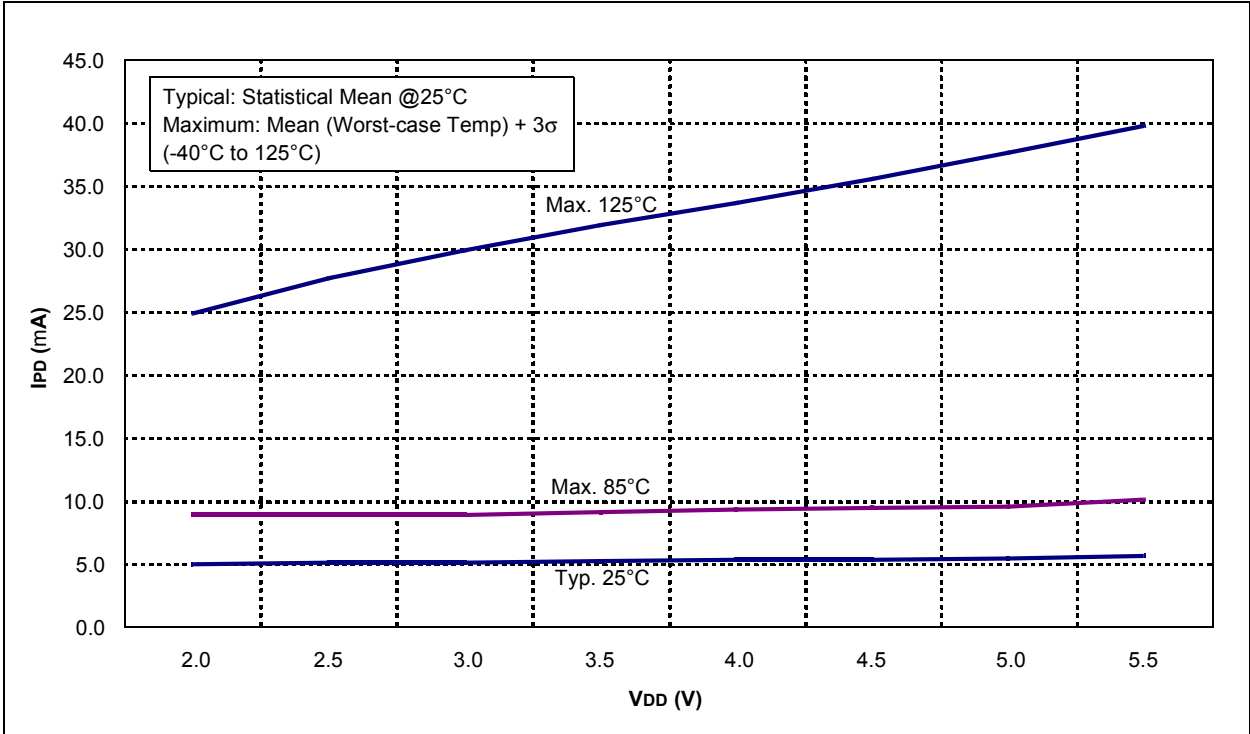
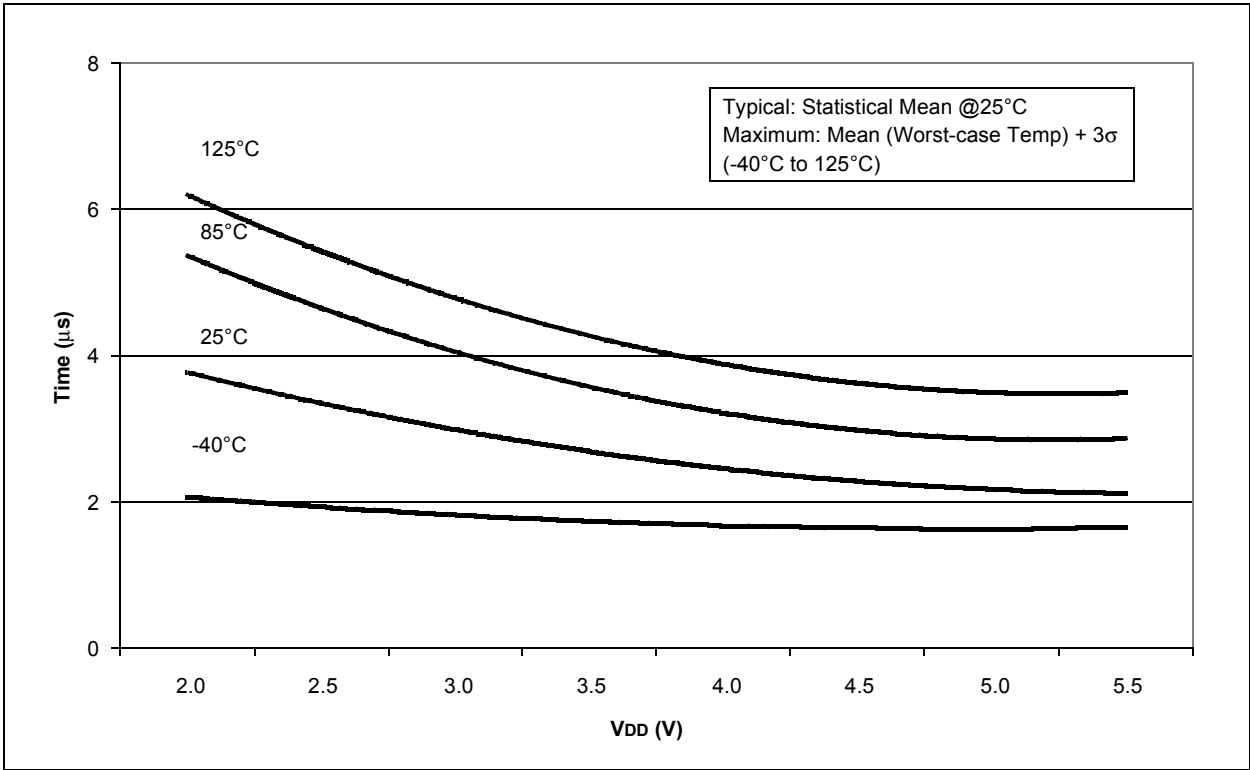


FIGURE 13-24: ADC CLOCK PERIOD vs. VDD OVER TEMPERATURE



# PIC16F716

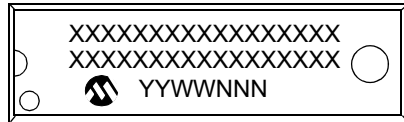
---

NOTES:

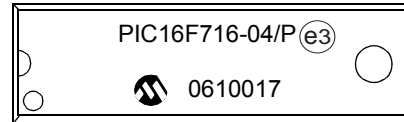
## 14.0 PACKAGING INFORMATION

### 14.1 Package Marking Information

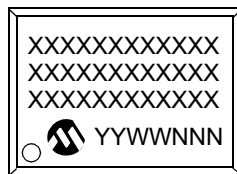
18-Lead PDIP



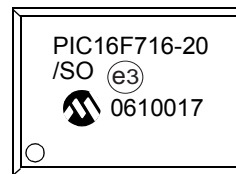
Example



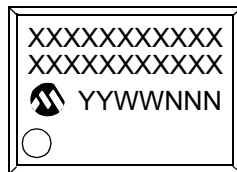
18-Lead SOIC (7.50 mm)



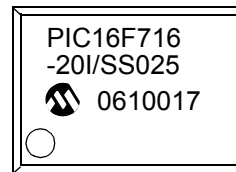
Example



20-Lead SSOP



Example



<b>Legend:</b>	XX...X	Customer-specific information
	Y	Year code (last digit of calendar year)
	YY	Year code (last 2 digits of calendar year)
	WW	Week code (week of January 1 is week '01')
	NNN	Alphanumeric traceability code
	(e3)	Pb-free JEDEC designator for Matte Tin (Sn)
	*	This package is Pb-free. The Pb-free JEDEC designator (e3) can be found on the outer packaging for this package.
<b>Note:</b>	In the event the full Microchip part number cannot be marked on one line, it will be carried over to the next line, thus limiting the number of available characters for customer-specific information.	

\* Standard PIC® device marking consists of Microchip part number, year code, week code, and traceability code. For PIC® device marking beyond this, certain price adders apply. Please check with your Microchip Sales Office. For QTP devices, any special marking adders are included in QTP price.

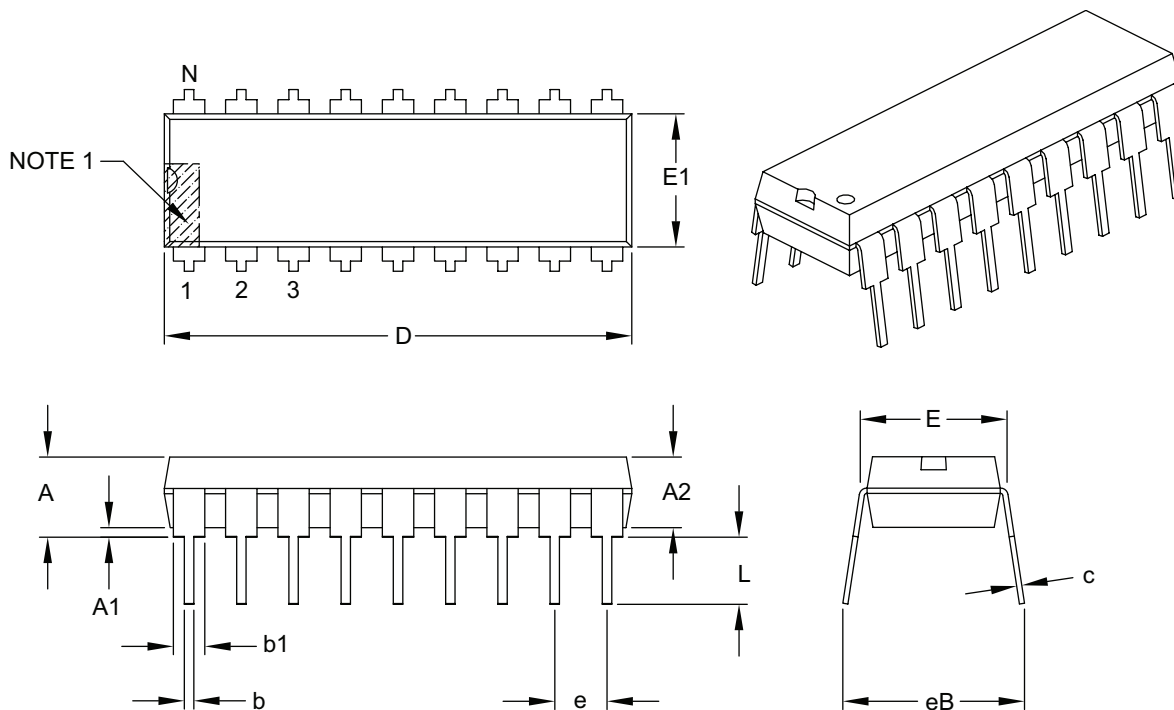
# PIC16F716

## 14.2 Package Details

The following sections give the technical details of the packages.

### 18-Lead Plastic Dual In-Line (P) – 300 mil Body [PDIP]

**Note:** For the most current package drawings, please see the Microchip Packaging Specification located at <http://www.microchip.com/packageing>



		Units	INCHES		
Dimension Limits			MIN	NOM	MAX
Number of Pins	N		18		
Pitch	e		.100 BSC		
Top to Seating Plane	A	–	–	–	.210
Molded Package Thickness	A2	.115	.130		.195
Base to Seating Plane	A1	.015	–	–	–
Shoulder to Shoulder Width	E	.300	.310		.325
Molded Package Width	E1	.240	.250		.280
Overall Length	D	.880	.900		.920
Tip to Seating Plane	L	.115	.130		.150
Lead Thickness	c	.008	.010		.014
Upper Lead Width	b1	.045	.060		.070
Lower Lead Width	b	.014	.018		.022
Overall Row Spacing §	eB	–	–		.430

**Notes:**

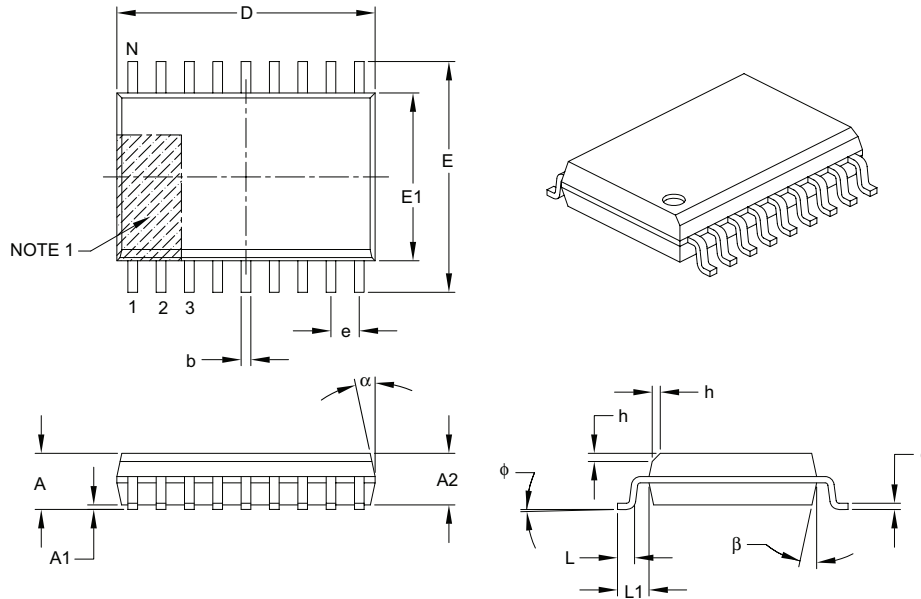
1. Pin 1 visual index feature may vary, but must be located within the hatched area.
2. § Significant Characteristic.
3. Dimensions D and E1 do not include mold flash or protrusions. Mold flash or protrusions shall not exceed .010" per side.
4. Dimensioning and tolerancing per ASME Y14.5M.

BSC: Basic Dimension. Theoretically exact value shown without tolerances.

Microchip Technology Drawing C04-007B

## 18-Lead Plastic Small Outline (SO) – Wide, 7.50 mm Body [SOIC]

**Note:** For the most current package drawings, please see the Microchip Packaging Specification located at <http://www.microchip.com/packaging>



Dimension Limits	Units	MILLIMETERS		
		MIN	NOM	MAX
Number of Pins	N	18		
Pitch	e	1.27 BSC		
Overall Height	A	–	–	2.65
Molded Package Thickness	A2	2.05	–	–
Standoff §	A1	0.10	–	0.30
Overall Width	E	10.30 BSC		
Molded Package Width	E1	7.50 BSC		
Overall Length	D	11.55 BSC		
Chamfer (optional)	h	0.25	–	0.75
Foot Length	L	0.40	–	1.27
Footprint	L1	1.40 REF		
Foot Angle	$\phi$	0°	–	8°
Lead Thickness	c	0.20	–	0.33
Lead Width	b	0.31	–	0.51
Mold Draft Angle Top	$\alpha$	5°	–	15°
Mold Draft Angle Bottom	$\beta$	5°	–	15°

**Notes:**

- Pin 1 visual index feature may vary, but must be located within the hatched area.
- § Significant Characteristic.
- Dimensions D and E1 do not include mold flash or protrusions. Mold flash or protrusions shall not exceed 0.15 mm per side.
- Dimensioning and tolerancing per ASME Y14.5M.

BSC: Basic Dimension. Theoretically exact value shown without tolerances.

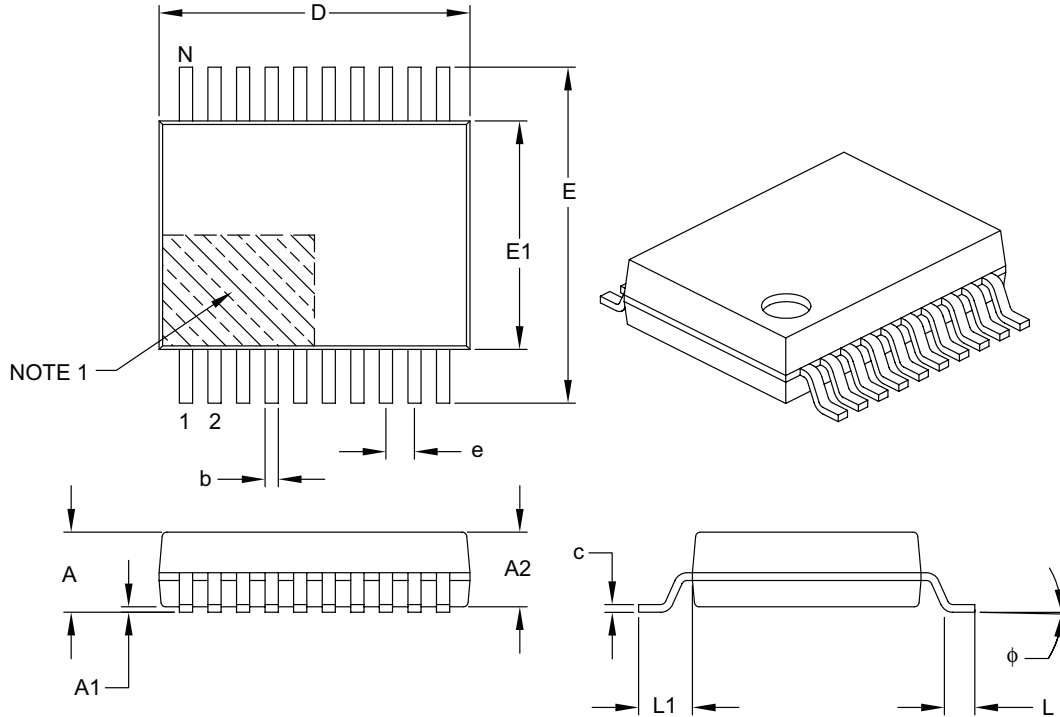
REF: Reference Dimension, usually without tolerance, for information purposes only.

Microchip Technology Drawing C04-051B

# PIC16F716

## 20-Lead Plastic Shrink Small Outline (SS) – 5.30 mm Body [SSOP]

**Note:** For the most current package drawings, please see the Microchip Packaging Specification located at <http://www.microchip.com/packaging>



Dimension Limits	Units	MILLIMETERS		
		MIN	NOM	MAX
Number of Pins	N	20		
Pitch	e	0.65 BSC		
Overall Height	A	–	–	2.00
Molded Package Thickness	A2	1.65	1.75	1.85
Standoff	A1	0.05	–	–
Overall Width	E	7.40	7.80	8.20
Molded Package Width	E1	5.00	5.30	5.60
Overall Length	D	6.90	7.20	7.50
Foot Length	L	0.55	0.75	0.95
Footprint	L1	1.25 REF		
Lead Thickness	c	0.09	–	0.25
Foot Angle	$\phi$	0°	4°	8°
Lead Width	b	0.22	–	0.38

**Notes:**

- Pin 1 visual index feature may vary, but must be located within the hatched area.
- Dimensions D and E1 do not include mold flash or protrusions. Mold flash or protrusions shall not exceed 0.20 mm per side.
- Dimensioning and tolerancing per ASME Y14.5M.

BSC: Basic Dimension. Theoretically exact value shown without tolerances.

REF: Reference Dimension, usually without tolerance, for information purposes only.

Microchip Technology Drawing C04-072B

## **APPENDIX A: REVISION HISTORY**

### **Revision A (June 2003)**

Original data sheet. However, the device described in this data sheet are upgrades to PIC16C716.

### **Revision B (February 2007)**

Updated with current formats and added Characterization Data. Replaced Package Drawings.

## **APPENDIX B: CONVERSION CONSIDERATIONS**

This is a Flash program memory version of the PIC16C716 device. Refer to the migration document, DS40059, for more information about differences between the PIC16F716 and PIC16C716.

# PIC16F716

---

## APPENDIX C: MIGRATION FROM BASE-LINE TO MID-RANGE DEVICES

This section discusses how to migrate from a baseline device (i.e., PIC16C5X) to a mid-range device (i.e., PIC16F716).

The following are the list of modifications over the PIC16C5X microcontroller family:

1. Instruction word length is increased to 14-bits. This allows larger page sizes both in program memory (2K now as opposed to 512 before) and register file (128 bytes now versus 32 bytes before).
2. A PC high latch register (PCLATH) is added to handle program memory paging. Bits PA2, PA1, PA0 are removed from STATUS register.
3. Data memory paging is redefined slightly. STATUS register is modified.
4. Four new instructions have been added: RETURN, RETFIE, ADDLW, and SUBLW. Two instructions TRIS and OPTION are being phased out although they are kept for compatibility with PIC16C5X.
5. OPTION\_REG and TRIS registers are made addressable.
6. Interrupt capability is added. Interrupt vector is at 0004h.
7. Stack size is increased to 8 deep.
8. Reset vector is changed to 0000h.
9. Reset of all registers is revisited. Five different Reset (and wake-up) types are recognized. Registers are reset differently.
10. Wake-up from Sleep through interrupt is added.
11. Two separate timers, Oscillator Start-up Timer (OST) and Power-up Timer (PWRT) are included for more reliable power-up. These timers are invoked selectively to avoid unnecessary delays on power-up and wake-up.
12. PORTB has weak pull-ups and interrupt-on-change feature.
13. T0CKI pin is also a port pin (RA4) now.
14. FSR is made a full eight-bit register.
15. "In-circuit serial programming" is made possible. The user can program PIC16F716 devices using only five pins: VDD, VSS, MCLR/VPP, RB6 (clock) and RB7 (data in/out).
16. PCON STATUS register is added with a Power-on Reset Status bit (POR).
17. Brown-out protection circuitry has been added. Controlled by Configuration Word bits BOREN and BORV. Brown-out Reset ensures the device is placed in a Reset condition if VDD dips below a fixed setpoint.

To convert code written for PIC16C5X to PIC16F716, the user should take the following steps:

1. Remove any program memory page select operations (PA2, PA1, PA0 bits) for CALL, GOTO.
2. Revisit any computed jump operations (write to PC or add to PC, etc.) to make sure page bits are set properly under the new scheme.
3. Eliminate any data memory page switching. Redefine data variables to reallocate them.
4. Verify all writes to STATUS, OPTION, and FSR registers since these have changed.
5. Change Reset vector to 0000h

**Note 1:** This device has been designed to perform to the parameters of its data sheet. It has been tested to an electrical specification designed to determine its conformance with these parameters. Due to process differences in the manufacture of this device, this device may have different performance characteristics than its earlier version. These differences may cause this device to perform differently in your application than the earlier version of this device.

- 2: The user should verify that the device oscillator starts and performs as expected. Adjusting the loading capacitor values and/or the Oscillator mode may be required.

## THE MICROCHIP WEB SITE

Microchip provides online support via our WWW site at [www.microchip.com](http://www.microchip.com). This web site is used as a means to make files and information easily available to customers. Accessible by using your favorite Internet browser, the web site contains the following information:

- **Product Support** – Data sheets and errata, application notes and sample programs, design resources, user's guides and hardware support documents, latest software releases and archived software
- **General Technical Support** – Frequently Asked Questions (FAQ), technical support requests, online discussion groups, Microchip consultant program member listing
- **Business of Microchip** – Product selector and ordering guides, latest Microchip press releases, listing of seminars and events, listings of Microchip sales offices, distributors and factory representatives

## CUSTOMER CHANGE NOTIFICATION SERVICE

Microchip's customer notification service helps keep customers current on Microchip products. Subscribers will receive e-mail notification whenever there are changes, updates, revisions or errata related to a specified product family or development tool of interest.

To register, access the Microchip web site at [www.microchip.com](http://www.microchip.com), click on Customer Change Notification and follow the registration instructions.

## CUSTOMER SUPPORT

Users of Microchip products can receive assistance through several channels:

- Distributor or Representative
- Local Sales Office
- Field Application Engineer (FAE)
- Technical Support
- Development Systems Information Line

Customers should contact their distributor, representative or field application engineer (FAE) for support. Local sales offices are also available to help customers. A listing of sales offices and locations is included in the back of this document.

**Technical support is available through the web site at: <http://support.microchip.com>**

# PIC16F716

---

---

## READER RESPONSE

It is our intention to provide you with the best documentation possible to ensure successful use of your Microchip product. If you wish to provide your comments on organization, clarity, subject matter, and ways in which our documentation can better serve you, please FAX your comments to the Technical Publications Manager at (480) 792-4150.

Please list the following information, and use this outline to provide us with your comments about this document.

To: Technical Publications Manager  
RE: Reader Response  
Total Pages Sent \_\_\_\_\_

From: Name \_\_\_\_\_  
Company \_\_\_\_\_  
Address \_\_\_\_\_  
City / State / ZIP / Country \_\_\_\_\_  
Telephone: (\_\_\_\_\_) \_\_\_\_\_ - \_\_\_\_\_ FAX: (\_\_\_\_\_) \_\_\_\_\_ - \_\_\_\_\_

Application (optional):

Would you like a reply? \_\_\_Y \_\_\_N

Device: PIC16F716

Literature Number: DS41206B

Questions:

1. What are the best features of this document?

---

---

2. How does this document meet your hardware and software development needs?

---

---

3. Do you find the organization of this document easy to follow? If not, why?

---

---

4. What additions to the document do you think would enhance the structure and subject?

---

---

5. What deletions from the document could be made without affecting the overall usefulness?

---

---

6. Is there any incorrect or misleading information (what and where)?

---

---

7. How would you improve this document?

---

---

## INDEX

### A

A/D	
ADCON0 Register	9
ADCON1 Register	10
ADRES Register	9
Converter Characteristics	104
Timing Diagram	105
Absolute Maximum Ratings	91
ADC	37
Acquisition Requirements	43
Associated registers	45
Block Diagram	37
Calculating Acquisition Time	43
Channel Selection	38
Configuration	38
Configuring Interrupt	40
Conversion Clock	38
Conversion Procedure	40
Internal Sampling Switch (Rss) IMPEDANCE	43
Interrupts	39
Operation	40
Operation During Sleep	40
Port Configuration	38
Reference Voltage (VREF)	38
Source Impedance	43
Special Event Trigger	40
ADCON0 Register	9, 41
ADCON1 Register	10, 42
ADRES Register	9
Analog-to-Digital Converter. <i>See</i> ADC	
Assembler	
MPASM Assembler	88
<b>B</b>	
Banking, Data Memory	7
Block Diagrams	
(CCP) Capture Mode Operation	48
ADC	37
ADC Transfer Function	44
Analog Input Model	44
Auto-Shutdown	56
CCP PWM	52
Compare	50
Interrupt Sources	72
On-Chip Reset Circuit	66
PIC16F716	5
PORTA	19, 20
PORTB	21
RB1/T1OSO/T1CKI	22
RB2/T1OSI	22
RB3/CCP1/P1A	23
RB4	23
RB5	24
RB6/P1C	24
RB7/P1D	25
Timer1	29
Timer2	35
TMR0/WDT Prescaler	27
Watchdog Timer (WDT)	74
BOR. <i>See</i> Brown-out Reset	
Brown-out Reset (BOR)	61, 64, 65, 69, 70
Timing Diagram	101

### C

C Compilers	
MPLAB C18	88
MPLAB C30	88
Capture Module. <i>See</i> Enhanced Capture/Compare/ PWM(ECCP)	
Capture/Compare/PWM (CCP)	
Associated registers w/ Capture	49
Associated registers w/ Compare	51
Associated registers w/ PWM	60
Capture Mode	48
CCP1 Pin Configuration	48
CCP1CON Register	9
CCPR1H Register	9
CCPR1L Register	9
Compare Mode	50
CCP1 Pin Configuration	50
Software Interrupt Mode	48, 50
Special Event Trigger	50
Timer1 Mode Selection	48, 50
Flag (CCP1IF Bit)	15
Prescaler	48
PWM Mode	52
Duty Cycle	53
Effects of Reset	55
Example PWM Frequencies and Resolutions, 20 MHz	54
Example PWM Frequencies and Resolutions, 8 MHz	54
Operation in Sleep Mode	55
Setup for Operation	55
System Clock Frequency Changes	55
PWM Period	53
Setup for PWM Operation	55
Timing Diagram	103
CCP1CON (Enhanced) Register	47
Code Examples	
Assigning Prescaler to Timer0	28
Assigning Prescaler to WDT	28
Changing Between Capture Prescalers	48
How to Clear RAM Using Indirect Addressing	18
Initializing PORTA	19
Initializing PORTB	21
Code Protection	61, 76
Compare Module. <i>See</i> Enhanced Capture/ Compare/PWM (ECCP)	
CONFIG Register	62
Configuration Bits	61
Conversion Considerations	125
Customer Change Notification Service	127
Customer Notification Service	127
Customer Support	127
<b>D</b>	
Data Memory	7
Bank Select (RP Bits)	7
General Purpose Registers	8
Register File Map	8
Special Function Registers	9
DC Characteristics	93, 94, 95, 96
Development Support	87
Direct Addressing	18

# PIC16F716

## E

ECCP. See Enhanced Capture/Compare/PWM	
ECCPAS Register	57
Effects of Reset	
PWM mode	55
Electrical Characteristics	91
Enhanced Capture/Compare/PWM	47
Enhanced Capture/Compare/PWM (ECCP)	
Enhanced PWM Mode	
Auto-Restart	58
Auto-shutdown	56
Half-Bridge Application Examples	59
Programmable Dead Band Delay	59
Shoot-through Current	59
Timer Resources	47
Errata	4
External Power-on Reset Circuit	64

## F

Firmware Instructions	77
Fuses. See Configuration Bits	

## I

I/O Ports	19
ID Locations	61, 76
In-Circuit Serial Programming (ICSP)	61, 76
Indirect Addressing	18
FSR Register	8, 9, 18
INDF Register	9
Instruction Format	77
Instruction Set	77
ADDLW	79
ADDWF	79
ANDLW	79
ANDWF	79
BCF	79
BSF	79
BTFSC	79
BTFSS	80
CALL	80
CLRF	80
CLRW	80
CLRWD	80
COMF	80
DECF	80
DECFSZ	81
GOTO	81
INCF	81
INCFSZ	81
IORLW	81
IORWF	81
MOVF	82
MOVLW	82
MOVWF	82
NOP	82
RETFIE	83
RETLW	83
RETURN	83
RLF	84
RRF	84
SLEEP	84
SUBLW	84
SUBWF	85
SWAPF	85
XORLW	85

XORWF	85
Summary Table	78
INT Interrupt (RB0/INT). See Interrupt Sources	
INTCON Register	9, 13
Internal Sampling Switch (Rss) IMPEDANCE	43
Internet Address	127
Interrupt Sources	61, 72
Interrupt-on-Change (RB)	21
RB0/INT Pin, External	73
TMR0 Overflow	73
Interrupts	
ADC	40
TMR1	30
Interrupts, Context Saving During	73
Interrupts, Enable Bits	
Global Interrupt Enable (GIE Bit)	72
Interrupt-on-Change (RB) Enable (RBIE Bit)	73
Interrupts, Flag Bits	
CCP1 Flag (CCP1IF Bit)	15
Interrupt-on-Change (RB) Flag (RBIF Bit)	73
TMR0 Overflow Flag (TOIF Bit)	73

## M

Master Clear (MCLR)	
MCLR Reset, Normal Operation	64, 69, 70
MCLR Reset, Sleep	64, 69, 70
Memory Organization	
Data Memory	7
Program Memory	7
Microchip Internet Web Site	127
Migration from Base-Line to Mid-Range Devices	126
MPLAB ASM30 Assembler, Linker, Librarian	88
MPLAB ICD 2 In-Circuit Debugger	89
MPLAB ICE 2000 High-Performance Universal	
In-Circuit Emulator	89
MPLAB Integrated Development Environment Software	87
MPLAB PM3 Device Programmer	89
MPLAB REAL ICE In-Circuit Emulator System	89
MPLINK Object Linker/MPLIB Object Librarian	88

## O

OPCODE Field Descriptions	77
OPTION Register	12
OPTION_REG Register	10, 12
Oscillator	
Associated registers	33
Oscillator Configuration	61, 63
HS	63, 68
LP	63, 68
RC	63, 64, 68
XT	63, 68
Oscillator, WDT	74

## P

Packaging	121
PDIP Details	122
Paging, Program Memory	7, 17
PCON Register	16, 68
PICSTART Plus Development Programmer	90
PIE1 Register	10, 14
PIR1 Register	9, 15
CCP1IF Bit	15
Pointer, FSR	18
POR. See Power-on Reset	
PORTA	
Associated Registers	20

PORTA Register .....	9, 19	MCLR Reset. See MCLR	
TRISA Register .....	10, 19	Power-on Reset (POR). See Power-on Reset (POR)	
<b>PORTB</b>		Reset Conditions for PCON Register .....	69
Associated Registers .....	25	Reset Conditions for Program Counter .....	69
PORTB Register .....	9, 21	Reset Conditions for STATUS Register .....	69
RB Interrupt-on-Change .....	73	Timing Diagram .....	101
RB Interrupt-on-Change Enable (RBIE Bit) .....	73	WDT Reset. See Watchdog Timer (WDT)	
RB0/INT Pin, External .....	73	Revision History .....	125
RB7:RB4 Interrupt-on-Change Flag (RBIF Bit) .....	73	<b>S</b>	
TRISB Register .....	10, 21	Shoot-through Current .....	59
Power-down Mode. See Sleep		Sleep .....	61, 64, 75
Power-on Reset (POR) .....	61, 64, 69, 70	Software Simulator (MPLAB SIM) .....	88
Oscillator Start-up Timer (OST) .....	61, 65	Special Event Trigger .....	40
Power Control (PCON) Register .....	68	Special Features of the CPU .....	61
Power-down (PD Bit) .....	64	Special Function Registers .....	9
Power-on Reset Circuit, External .....	64	Speed, Operating .....	1
Power-up Timer (PWRT) .....	61, 65	Stack .....	17
Time-out (TO Bit) .....	64	STATUS Register .....	11
Time-out Sequence .....	68	STATUS Register .....	9, 73
Time-out Sequence on Power-up .....	71	PD Bit .....	64
Timing Diagram .....	101	TO Bit .....	64
<b>Prescaler</b>		<b>T</b>	
Shared WDT/Timer0 .....	28	T1CON Register .....	9, 32
Switching Prescaler Assignment .....	28	T2CON Register .....	9, 36
<b>Program Counter</b>		Timer0 .....	27
PCL Register .....	9, 17	Associated Registers .....	28
PCLATH Register .....	9, 17, 73	External Clock .....	28
Reset Conditions .....	69	Operation .....	27, 29
<b>Program Memory</b> .....	7	Overflow Flag (TOIF Bit) .....	73
Interrupt Vector .....	7	Overflow Interrupt .....	73
Paging .....	7, 17	T0CKI .....	28
Program Memory Map .....	7	Timing Diagram .....	102
Reset Vector .....	7	TMR0 Register .....	9
<b>Program Verification</b> .....	76	<b>Timer1</b> .....	29
<b>Programming, Device Instructions</b> .....	77	Associated registers .....	33
<b>PWM1CON Register</b> .....	60	Asynchronous Counter Mode .....	30
		Reading and Writing .....	30
		Interrupt .....	30
		Modes of Operation .....	29
		Operation During Sleep .....	30
		Oscillator .....	30
		Prescaler .....	30
		T1CON Register .....	9
		Timing Diagram .....	102
		TMR1H Register .....	9, 29
		TMR1L Register .....	9, 29
		<b>Timer2</b>	
		Associated registers .....	36
		PR2 Register .....	10
		T2CON Register .....	9
		TMR2 Register .....	9
		<b>Timers</b>	
		Timer1	
		T1CON .....	32
		Timer2	
		T2CON .....	36
		<b>Timing Diagrams</b>	
		Half-Bridge PWM Output .....	59
		PWM Auto-shutdown	
		Auto-restart Enabled .....	58
		Firmware Restart .....	58
		Time-out Sequence on Power-up .....	71
		Timer1 Incrementing Edge .....	31
		Wake-up from Sleep via Interrupt .....	76
<b>Reset</b> .....	61, 64		
Brown-out Reset (BOR). See Brown-out Reset (BOR)			

# PIC16F716

---

Timing Diagrams and Specifications .....	98
A/D Conversion .....	105
Brown-out Reset (BOR) .....	101
Capture/Compare/PWM (CCP) .....	103
CLKOUT and I/O .....	100
External Clock .....	98
Oscillator Start-up Timer (OST) .....	101
Power-up Timer (PWRT) .....	101
Reset .....	101
Timer0 and Timer1 .....	102
Watchdog Timer (WDT) .....	101

## V

VREF. *SEE* ADC Reference Voltage

## W

W Register .....	73
Wake-up from Sleep .....	61, 75
Interrupts .....	69, 70
MCLR Reset .....	70
Timing Diagram .....	76
WDT Reset .....	70
Watchdog Timer (WDT) .....	61, 74
Enable (WDTE Bit) .....	74
Postscaler. <i>See</i> Postscaler, WDT	
Programming Considerations .....	74
RC Oscillator .....	74
Time-out Period .....	74
Timing Diagram .....	101
WDT Reset, Normal Operation .....	64, 69, 70
WDT Reset, Sleep .....	64, 69, 70
WWW Address .....	127
WWW, On-Line Support .....	4

## PRODUCT IDENTIFICATION SYSTEM

To order or obtain information, e.g., on pricing or delivery, refer to the factory or the listed sales office.

<u>PART NO.</u>	<u>X</u>	<u>/XX</u>	<u>XXX</u>
Device	Temperature Range	Package	Pattern
<p><b>Device:</b> PIC16F716<sup>(1)</sup>, PIC16F716T<sup>(2)</sup>; VDD range 2.0V to 5.5V</p> <p><b>Temperature Range:</b> I = -40°C to +85°C (Industrial) E = -40°C to +125°C (Extended)</p> <p><b>Package:</b> SO = SOIC P = PDIP SS = SSOP</p> <p><b>Pattern:</b> QTP, SQTP, Code or Special Requirements (blank otherwise)</p>			
<p><b>Examples:</b></p> <p>a) PIC16F716 - I/L 301 = Industrial temp., PDIP package, QTP pattern #301.</p> <p>b) PIC16F716 - E/SO = Extended temp., SOIC package.</p>			
<p><b>Note 1:</b> F = Standard Voltage Range LF = Wide Voltage Range</p> <p><b>2:</b> T = in tape and reel SOIC and SSOP packages only.</p>			



---

---

## WORLDWIDE SALES AND SERVICE

---

---

### AMERICAS

#### Corporate Office

2355 West Chandler Blvd.  
Chandler, AZ 85224-6199  
Tel: 480-792-7200  
Fax: 480-792-7277  
Technical Support:  
<http://support.microchip.com>  
Web Address:  
[www.microchip.com](http://www.microchip.com)

#### Atlanta

Duluth, GA  
Tel: 678-957-9614  
Fax: 678-957-1455

#### Boston

Westborough, MA  
Tel: 774-760-0087  
Fax: 774-760-0088

#### Chicago

Itasca, IL  
Tel: 630-285-0071  
Fax: 630-285-0075

#### Dallas

Addison, TX  
Tel: 972-818-7423  
Fax: 972-818-2924

#### Detroit

Farmington Hills, MI  
Tel: 248-538-2250  
Fax: 248-538-2260

#### Kokomo

Kokomo, IN  
Tel: 765-864-8360  
Fax: 765-864-8387

#### Los Angeles

Mission Viejo, CA  
Tel: 949-462-9523  
Fax: 949-462-9608

#### Santa Clara

Santa Clara, CA  
Tel: 408-961-6444  
Fax: 408-961-6445

#### Toronto

Mississauga, Ontario,  
Canada  
Tel: 905-673-0699  
Fax: 905-673-6509

### ASIA/PACIFIC

#### Asia Pacific Office

Suites 3707-14, 37th Floor  
Tower 6, The Gateway  
Harbour City, Kowloon  
Hong Kong  
Tel: 852-2401-1200  
Fax: 852-2401-3431

#### Australia - Sydney

Tel: 61-2-9868-6733  
Fax: 61-2-9868-6755

#### China - Beijing

Tel: 86-10-8528-2100  
Fax: 86-10-8528-2104

#### China - Chengdu

Tel: 86-28-8665-5511  
Fax: 86-28-8665-7889

#### China - Fuzhou

Tel: 86-591-8750-3506  
Fax: 86-591-8750-3521

#### China - Hong Kong SAR

Tel: 852-2401-1200  
Fax: 852-2401-3431

#### China - Qingdao

Tel: 86-532-8502-7355  
Fax: 86-532-8502-7205

#### China - Shanghai

Tel: 86-21-5407-5533  
Fax: 86-21-5407-5066

#### China - Shenyang

Tel: 86-24-2334-2829  
Fax: 86-24-2334-2393

#### China - Shenzhen

Tel: 86-755-8203-2660  
Fax: 86-755-8203-1760

#### China - Shunde

Tel: 86-757-2839-5507  
Fax: 86-757-2839-5571

#### China - Wuhan

Tel: 86-27-5980-5300  
Fax: 86-27-5980-5118

#### China - Xian

Tel: 86-29-8833-7250  
Fax: 86-29-8833-7256

### ASIA/PACIFIC

#### India - Bangalore

Tel: 91-80-4182-8400  
Fax: 91-80-4182-8422

#### India - New Delhi

Tel: 91-11-4160-8631  
Fax: 91-11-4160-8632

#### India - Pune

Tel: 91-20-2566-1512  
Fax: 91-20-2566-1513

#### Japan - Yokohama

Tel: 81-45-471-6166  
Fax: 81-45-471-6122

#### Korea - Gumi

Tel: 82-54-473-4301  
Fax: 82-54-473-4302

#### Korea - Seoul

Tel: 82-2-554-7200  
Fax: 82-2-558-5932 or  
82-2-558-5934

#### Malaysia - Penang

Tel: 60-4-646-8870  
Fax: 60-4-646-5086

#### Philippines - Manila

Tel: 63-2-634-9065  
Fax: 63-2-634-9069

#### Singapore

Tel: 65-6334-8870  
Fax: 65-6334-8850

#### Taiwan - Hsin Chu

Tel: 886-3-572-9526  
Fax: 886-3-572-6459

#### Taiwan - Kaohsiung

Tel: 886-7-536-4818  
Fax: 886-7-536-4803

#### Taiwan - Taipei

Tel: 886-2-2500-6610  
Fax: 886-2-2508-0102

#### Thailand - Bangkok

Tel: 66-2-694-1351  
Fax: 66-2-694-1350

### EUROPE

#### Austria - Wels

Tel: 43-7242-2244-39  
Fax: 43-7242-2244-393

#### Denmark - Copenhagen

Tel: 45-4450-2828  
Fax: 45-4485-2829

#### France - Paris

Tel: 33-1-69-53-63-20  
Fax: 33-1-69-30-90-79

#### Germany - Munich

Tel: 49-89-627-144-0  
Fax: 49-89-627-144-44

#### Italy - Milan

Tel: 39-0331-742611  
Fax: 39-0331-466781

#### Netherlands - Drunen

Tel: 31-416-690399  
Fax: 31-416-690340

#### Spain - Madrid

Tel: 34-91-708-08-90  
Fax: 34-91-708-08-91

#### UK - Wokingham

Tel: 44-118-921-5869  
Fax: 44-118-921-5820

12/08/06

## Looking for pricing, stock, or lifecycle information?

Click below to explore more details on WIN SOURCE:

- ⊖ [View PIC16F716-E/SO on WIN SOURCE](#)
- ⊖ [Microchip Technology](#) Information

## Optimize Your Supply Chain with WIN SOURCE Solutions

- ✓ Global Sourcing Solution
- ✓ Obsolete Management
- ✓ Cost Control Management
- ✓ Shortage Management
- ✓ Alternative Solution
- ✓ Excess Inventory Management