



# PIC16(L)F1764/5/8/9

---

## 14/20-Pin, 8-Bit Flash Microcontroller Product Brief

---

### Description:

PIC16(L)F176X microcontrollers combine intelligent analog integration with digital peripherals to suit a variety of functions and end equipment. These 14/20-pin devices provide features like 10-bit A/D, op amps, zero-cross detect, high current I/Os, communication, peripheral pin select and other key peripherals that make this family appealing in applications looking for design flexibility.

### Core Features:

- C Compiler Optimized RISC Architecture
- Only 49 Instructions
- Operating Speed:
  - DC – 32 MHz clock input
  - 125 ns minimum instruction cycle
- Interrupt Capability
- 16-Level Deep Hardware Stack
- Up to Four 8-Bit Timers
- Up to Three 16-Bit Timers
- Power-on Reset (POR)
- Configurable Power-up Timer (PWRT)
- Brown-out Reset (BOR) with Selectable Trip Point
- Extended Watchdog Timer (EWDT):
  - Low-power 31 kHz WDT
  - Software-selectable prescaler
  - Software-selectable enable

### Memory:

- Up to 14 KB Flash Program Memory
- Up to 1024 Bytes Data RAM Memory
- Direct, Indirect and Relative Addressing modes
- High Endurance Flash (HEF)
  - 128B of nonvolatile data storage
  - 100K Erase/Write cycles

### Operating Characteristics:

- Operating Voltage Range:
  - 1.8V to 3.6V (PIC16LF176X)
  - 2.3V to 5.5V (PIC16F176X)
- Temperature Range:
  - Industrial: -40°C to 85°C
  - Extended: -40°C to 125°C

### eXtreme Low-Power (XLP) Features:

- Sleep mode: 50 nA @ 1.8V, typical
- Watchdog Timer: 500 nA @ 1.8V, typical
- Secondary Oscillator 500 nA @ 32 kHz
- Operating Current:
  - 8 uA @ 32 kHz, 1.8V, typical
  - 32 uA/MHz @ 1.8V, typical
- Low-Power BOR (LPBOR):
  - 200 nA in Sleep

### Digital Peripherals:

- Configurable Logic Cell (CLC):
  - Up to three CLCs; up to four selected inputs
  - Integrated combinational and state logic
- Up to Two Complementary Output Generators (COG):
  - Push-Pull, Full-Bridge and Steering modes
- Up to Two Capture/Compare/PWM (CCP) modules
- Pulse-Width Modulators (PWM):
  - Up to two 10-bit PWMs
  - Up to two 16-bit PWMs
- Peripheral Pin Select (PPS):
  - Configure any digital pin to output
- Serial Communications:
  - Enhanced USART (EUSART)
  - SPI, I<sup>2</sup>C™, RS-232, RS-485, LIN compatible
  - Auto-Baud Detect, auto-wake-up on start
- Up to 18 I/O Pins:
  - Individually programmable pull-ups
  - Slew rate control
  - Interrupt-on-change with edge-select
- Up to Two Data Signal Modulators (DSM)

### Intelligent Analog Peripherals:

- 10-Bit Analog-to-Digital Converter (ADC):
  - Up to 12 external channels
  - Conversion available during Sleep
- Up to Two Operational Amplifiers (OPA):
  - Selectable internal and external channels
  - High and low GBWP operating modes
- Up to Four Fast Comparators (COMP):
  - Low-Power/High-Speed mode
  - Up to five external inverting inputs
  - Up to eight external non-inverting inputs
  - Fixed Voltage Reference at non-inverting input(s)
  - Comparator outputs externally accessible
- Digital-to-Analog Converters (DAC):
  - Up to two 10-bit resolution DACs
  - Up to two 5-bit resolution DACs

# PIC16(L)F1764/5/8/9

- Voltage Reference:
  - Fixed Voltage Reference (FVR): 1.024V, 2.048V and 4.096V output levels
- Zero-Cross Detector (ZCD):
  - Detect high voltage AC signal
- Programmable Ramp Generator (PRG)
  - Slope compensation
  - Ramp generation
- High Current Drive I/Os:
  - 100 mA capacity
  - Low voltage

## Clocking Structure:

- 16 MHz Internal Oscillator:
  - $\pm 1\%$  at calibration
  - Selectable frequency range 32 MHz to 31 kHz
- 31 kHz Low-Power Internal Oscillator
- 4x Phase-Locked Loop (PLL):
  - For up to 32 MHz internal operation
- External Oscillator Block with:
  - Three external clock modes up to 32 MHz

**TABLE 1: PIC16(L)F1764/5/8/9 FAMILY TYPES**

Device	Data Sheet Index	Program Memory Flash (words)	High-Endurance Flash (B)	Data SRAM (bytes)	I/O Pins	8/16-bit Timer	Comparator	10-bit ADC (ch)	5/10-bit DAC	CCP	10/16-bit PWM	COG	DSM	CLC	Op Amp	Zero-Cross Detect	Programmable Ramp Gen	High Current I/Os	Peripheral Pin Select	EUSART	I <sup>2</sup> C™/SPI	Debug <sup>(1)</sup>
PIC16(L)F1764	(A)	4096	128	512	12	4/3	2	8	1/1	1	1/1	1	1	3	1	1	1	2	Y	1	1	I/H
PIC16(L)F1765	(A)	8192	128	1024	12	4/3	2	8	1/1	1	1/1	1	1	3	1	1	1	2	Y	1	1	I/H
PIC16(L)F1768	(B)	4096	128	512	18	4/3	4	12	2/2	2	2/2	2	2	3	2	1	2	2	Y	1	1	I/H
PIC16(L)F1769	(B)	8192	128	1024	18	4/3	4	12	2/2	2	2/2	2	2	3	2	1	2	2	Y	1	1	I/H

**Note 1:** Debugging Methods: (I) – Integrated on Chip; (H) – via ICD header; E – Emulation Product.

**Data Sheet Index:**

- A. Future Release [PIC16\(L\)F1764/5 Data Sheet, 14-Pin, 8-bit Flash Microcontrollers.](#)
- B. Future Release [PIC16\(L\)F1768/9 Data Sheet, 20-Pin, 8-bit Flash Microcontrollers.](#)

**Note:** For other small form-factor package availability and marking information, please visit <http://www.microchip.com/packaging> or contact your local sales office.

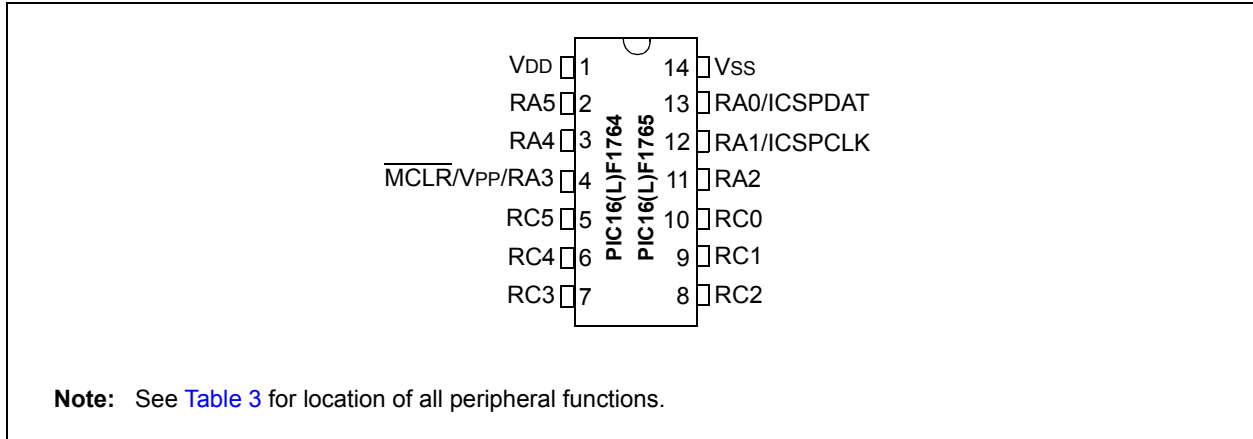
**TABLE 2: PACKAGES**

Packages	PDIP	SOIC	TSSOP	QFN	SSOP
PIC16(L)F1764	X	X	X	X	
PIC16(L)F1765	X	X	X	X	
PIC16(L)F1768	X	X		X	X
PIC16(L)F1769	X	X		X	X

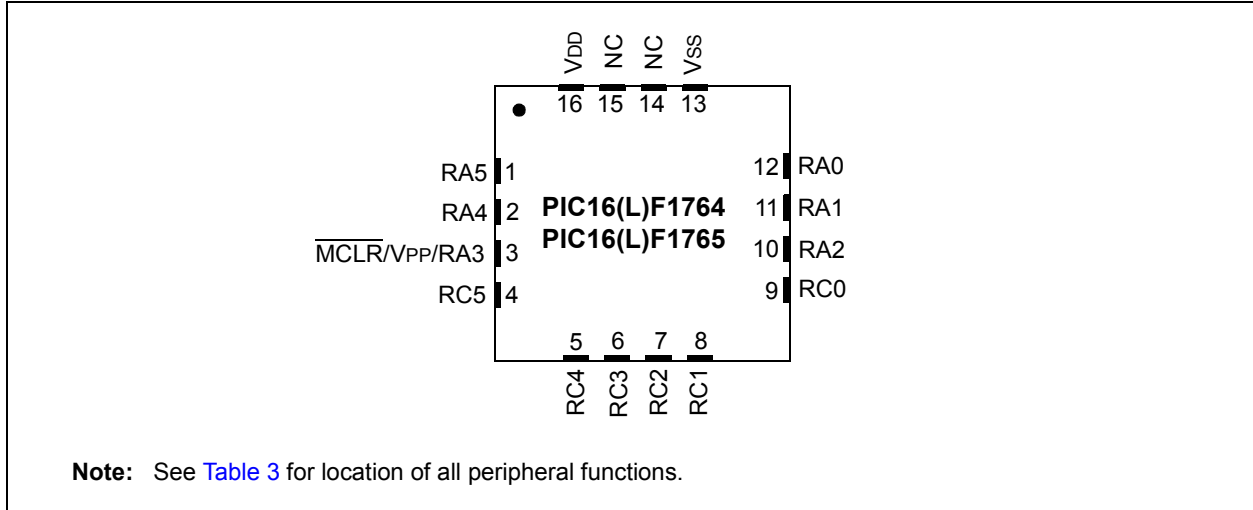
**Note:** Pin details are subject to change.

## PIN DIAGRAMS

**FIGURE 1: 14-PIN PDIP, SOIC, TSSOP**

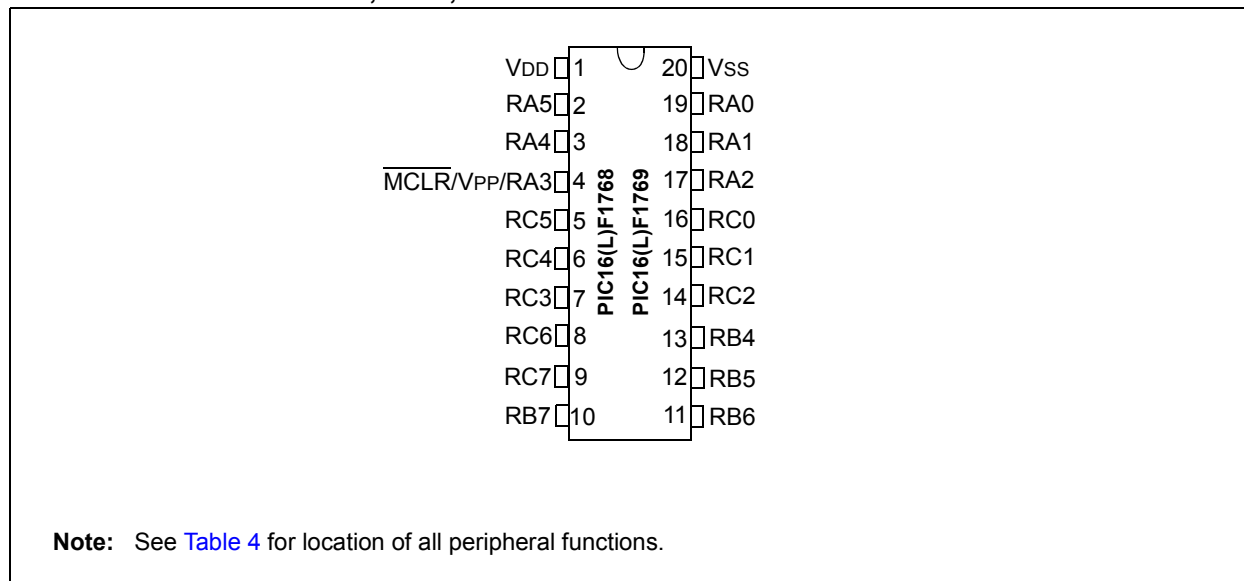


**FIGURE 2: 16-PIN QFN (4x4)**

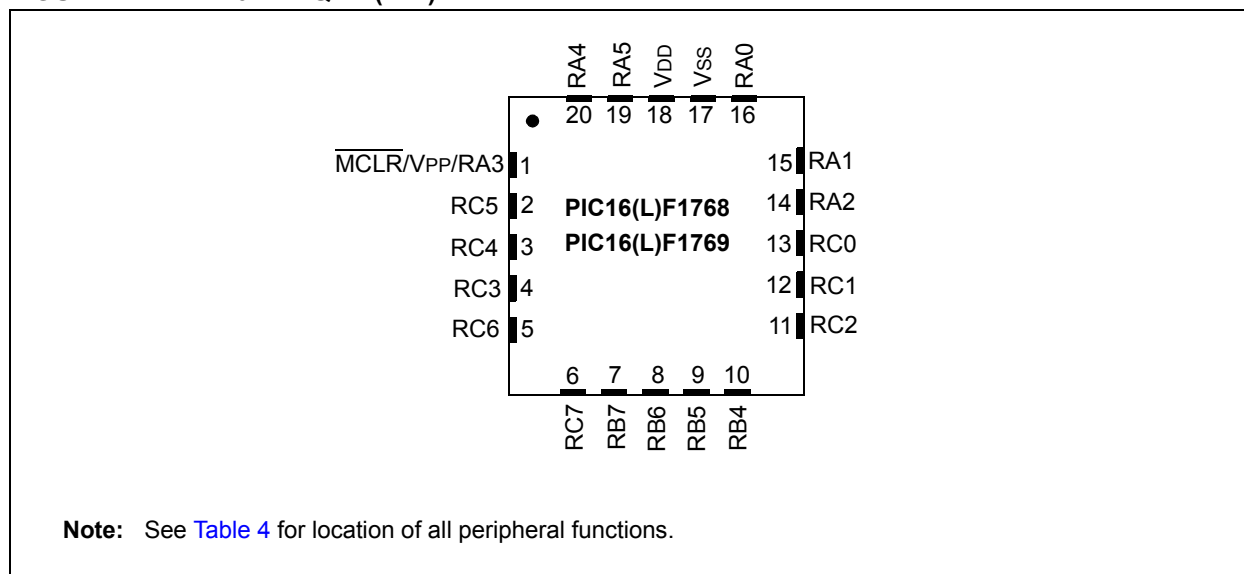


# PIC16(L)F1764/5/8/9

**FIGURE 3: 20-PIN PDIP, SOIC, SSOP**



**FIGURE 4: 20-PIN QFN (4x4)**



# PIN ALLOCATION TABLES

## TABLE 3: 14-PIN AND 16-PIN ALLOCATION TABLE (PIC16(L)F1764 AND PIC16(L)F1765)

I/O	14-Pin PDIP/SOIC/TSSOP		16-Pin QFN		ADC	Reference	DAC	Op Amp	Comparator	Zero Cross	Ramp Generator	Timers	PWM	GCP	COG	CLC	DSM	EUSART
	13	12	11	10														
RA0	—	AN0	VREF- DAC1REF- DAC2REF-	DAC1OUT1 DAC2OUT1	—	—	—	C1IN0+ C2IN0+	—	—	—	—	—	—	—	—	—	—
RA1	—	AN1	VREF+ DAC1REF+ DAC2REF+	—	—	—	C1IN0- C2IN0-	—	—	—	—	—	—	—	—	—	—	—
RA2	11	AN2	—	—	ZCD	—	—	—	TOCK(1)	—	—	—	—	—	COG1IN(1)	—	—	—
RA3	4	3	—	—	—	—	—	—	T6CK(1)	—	—	—	—	—	—	DSM1CH(1)	—	—
RA4	3	AN3	—	—	—	—	—	—	T1G(1) SOSCO	—	—	—	—	—	—	DSM1CL(1)	—	—
RA5	2	1	—	—	—	—	—	—	T1CK(1) T2CK(1) SOSCI	—	—	—	—	—	—	DSM1MOD(1)	—	—
RC0	10	AN4	—	—	—	—	OPA1IN+	C2IN0+	—	—	—	—	—	—	—	—	—	—
RC1	9	AN5	—	—	—	—	OPA1IN-	C1IN1- C2IN1-	—	—	—	T4CK(1)	—	—	—	CLCIN2(1)	—	—
RC2	8	AN6	—	—	—	—	OPA1OUT	C1IN2- C2IN2-	RG1IN0	—	—	—	—	—	—	—	—	—
RC3	7	AN7	—	—	—	—	—	C1IN3- C2IN3-	—	—	—	T5G(1)	—	—	—	CLCIN0(1)	—	—
RC4	6	5	—	—	—	—	—	—	RG1R(1)	—	—	T3G(1)	—	—	—	CLCIN1(1)	—	OK(1)
RC5	5	4	—	—	—	—	—	—	RG1F(1)	—	—	T3CK(1)	—	CCP1(1)	—	—	—	RX(1,3)
VDD	1	16	—	—	—	—	—	—	—	—	—	—	—	—	—	—	—	—
VSS	14	13	—	—	—	—	—	—	—	—	—	—	—	—	—	—	—	—
OUT(2)	—	—	—	—	—	—	C1OUT	C2OUT	—	—	—	—	PWM3OUT	—	—	CLC1OUT	DSM1OUT	DT(3)
—	—	—	—	—	—	—	—	—	—	—	—	—	PWM5OUT	—	—	CLC2OUT	—	TX
—	—	—	—	—	—	—	—	—	—	—	—	—	—	—	—	CLC3OUT	—	OK
—	—	—	—	—	—	—	—	—	—	—	—	—	—	—	—	—	—	—

**Note** 1: Default peripheral input. Input can be moved to any other pin with the PPS input selection register.

2: All pin outputs default to POKT latch data. Any pin can be selected as a digital peripheral output with the PPS output selection registers.

3: These peripheral functions are bidirectional. The output pin selections must be the same as the input pin selections.

TABLE 4: 20-PIN ALLOCATION TABLE ( PIC16(L)F1768 AND PIC16(L)F1769)

I/O	20-Pin PDIP/SOIC/SSOP	20-Pin QFN	ADC	Reference	DAC	Op Amp	Comparator	Zero Cross	Ramp Generator	Timers	PWM	CCP	COG	CLC	DSM	EUSART
RA0	19	16	AN0	VREF- DAC1REF- DAC2REF- DAC3REF- DAC4REF-	DAC1OUT1 DAC2OUT1 DAC3OUT1 DAC4OUT1	—	C1IN0+ C3IN0+	—	—	—	—	—	—	—	—	—
RA1	18	15	AN1	VREF+ DAC1REF+ DAC2REF+ DAC3REF+ DAC4REF+	—	—	C1IN0- C2IN0- C3IN0- C4IN0-	—	—	—	—	—	—	—	—	—
RA2	17	14	AN2	—	—	—	—	ZCD	—	TOCK1(1)	—	—	COG1IN(1) COG2IN(1)	—	—	—
RA3	4	1	—	—	—	—	—	—	—	T6CK1(1)	—	—	—	DSM1CH(1) DSM2CH(1)	—	—
RA4	3	20	AN3	—	—	—	—	—	—	T1G(1) SOSCO	—	—	—	DSM1TL(1) DSM2CL(1)	—	—
RA5	2	19	—	—	—	—	—	—	—	T1CK1(1) T2CK1(1) SOSCI	—	—	—	DSM1MOD(1) DSM2MOD(1)	—	—
RB4	13	10	AN10	—	—	OPA1IN0-	—	—	—	—	—	—	—	—	—	—
RB5	12	9	AN11	—	—	OPA1IN0+	—	—	—	—	—	—	—	—	—	RX(1:3)
RB6	11	8	—	—	—	—	C1IN1+ C3IN1+	—	—	—	—	—	—	—	—	—
RB7	10	7	—	—	—	—	C2IN1- C4IN1+	—	—	—	—	—	—	—	—	CK(1)
RC0	16	13	AN4	—	—	—	C2IN0- C4IN0+	—	—	T5CK1(1)	—	—	—	—	—	—
RC1	15	12	AN5	—	—	—	C1IN1- C2IN1- C3IN1- C4IN1-	—	—	T4CK1(1)	—	—	—	CLCIN2(1)	—	—
RC2	14	11	AN6	—	—	OPA1OUT OPA2IN1- OPA2IN1+	C1IN2- C2IN2-	—	RG1IN0 RG2IN1	—	—	—	—	—	—	—

**Note** 1: Default peripheral input. Input can be moved to any other pin with the PPS input selection register.

2: All pin outputs default to PORT1 latch data. Any pin can be selected as a digital peripheral output with the PPS output selection registers.

3: These peripheral functions are bidirectional. The output pin selections must be the same as the input pin selections.

**TABLE 4: 20-PIN ALLOCATION TABLE ( PIC16(L)F1768 AND PIC16(L)F1769)**

I/O	20-Pin PDIP/SOIC/SSOP	20-Pin QFN	ADC	Reference	DAC	Op Amp	Comparator	Zero Cross	Ramp Generator	Timers	PWM	CCP	COG	CLC	DSM	EUSART
RC3	7	4	AN7	—	—	OPA2OUT OPA1IN1- OPA1IN1+	C1IN3- C2IN3- C3IN3- C4IN3-	—	RG2IN0 RG1IN1	T5G(1)	—	CCP2(1)	—	CLCIN0(1)	—	—
RC4	6	3	—	—	—	—	—	—	RG1R(1) RG2R(1)	T3G(1)	—	—	—	CLCIN1(1)	—	—
RC5	5	2	—	—	—	—	—	—	RG1F(1) RG2F(1)	T3CK(1)	—	CCP1(1)	—	—	—	—
RC6	8	5	AN8	—	—	OPA2IN0-	—	—	—	—	—	—	—	—	—	—
RC7	9	6	AN9	—	—	OPA2IN0+	—	—	—	—	—	—	—	—	—	—
VDD	1	18	—	—	—	—	—	—	—	—	—	—	—	—	—	—
VSS	20	17	—	—	—	—	—	—	—	—	—	—	—	—	—	—
OUT(2)	—	—	—	—	—	—	C1OUT	—	—	—	PWM3OUT	CCP1	COG1A	CLC1OUT	DSM1OUT	DT(3)
	—	—	—	—	—	—	C2OUT	—	—	—	PWM4OUT	CCP2	COG1B	CLC2OUT	DSM2OUT	TX
	—	—	—	—	—	—	C3OUT	—	—	—	PWM5OUT	—	COG1C	CLC3OUT	—	CK
	—	—	—	—	—	—	C4OUT	—	—	—	PWM6OUT	—	COG1D	—	—	—
	—	—	—	—	—	—	—	—	—	—	—	—	COG2A	—	—	—
	—	—	—	—	—	—	—	—	—	—	—	—	COG2B	—	—	—
	—	—	—	—	—	—	—	—	—	—	—	—	COG2C	—	—	—
	—	—	—	—	—	—	—	—	—	—	—	—	COG2D	—	—	—

**Note**  
**1:** Default peripheral input. Input can be moved to any other pin with the PPS input selection register.  
**2:** All pin outputs default to PORT latch data. Any pin can be selected as a digital peripheral output with the PPS output selection registers.  
**3:** These peripheral functions are bidirectional. The output pin selections must be the same as the input pin selections.

---

---

**Note the following details of the code protection feature on Microchip devices:**

- Microchip products meet the specification contained in their particular Microchip Data Sheet.
- Microchip believes that its family of products is one of the most secure families of its kind on the market today, when used in the intended manner and under normal conditions.
- There are dishonest and possibly illegal methods used to breach the code protection feature. All of these methods, to our knowledge, require using the Microchip products in a manner outside the operating specifications contained in Microchip's Data Sheets. Most likely, the person doing so is engaged in theft of intellectual property.
- Microchip is willing to work with the customer who is concerned about the integrity of their code.
- Neither Microchip nor any other semiconductor manufacturer can guarantee the security of their code. Code protection does not mean that we are guaranteeing the product as "unbreakable."

Code protection is constantly evolving. We at Microchip are committed to continuously improving the code protection features of our products. Attempts to break Microchip's code protection feature may be a violation of the Digital Millennium Copyright Act. If such acts allow unauthorized access to your software or other copyrighted work, you may have a right to sue for relief under that Act.

Information contained in this publication regarding device applications and the like is provided only for your convenience and may be superseded by updates. It is your responsibility to ensure that your application meets with your specifications. MICROCHIP MAKES NO REPRESENTATIONS OR WARRANTIES OF ANY KIND WHETHER EXPRESS OR IMPLIED, WRITTEN OR ORAL, STATUTORY OR OTHERWISE, RELATED TO THE INFORMATION, INCLUDING BUT NOT LIMITED TO ITS CONDITION, QUALITY, PERFORMANCE, MERCHANTABILITY OR FITNESS FOR PURPOSE. Microchip disclaims all liability arising from this information and its use. Use of Microchip devices in life support and/or safety applications is entirely at the buyer's risk, and the buyer agrees to defend, indemnify and hold harmless Microchip from any and all damages, claims, suits, or expenses resulting from such use. No licenses are conveyed, implicitly or otherwise, under any Microchip intellectual property rights.

#### Trademarks

The Microchip name and logo, the Microchip logo, dsPIC, FlashFlex, KEELOQ, KEELOQ logo, MPLAB, PIC, PICmicro, PICSTART, PIC<sup>32</sup> logo, rPIC, SST, SST Logo, SuperFlash and UNI/O are registered trademarks of Microchip Technology Incorporated in the U.S.A. and other countries.

FilterLab, Hampshire, HI-TECH C, Linear Active Thermistor, MTP, SEEVAL and The Embedded Control Solutions Company are registered trademarks of Microchip Technology Incorporated in the U.S.A.

Silicon Storage Technology is a registered trademark of Microchip Technology Inc. in other countries.


Analog-for-the-Digital Age, Application Maestro, BodyCom, chipKIT, chipKIT logo, CodeGuard, dsPICDEM, dsPICDEM.net, dsPICworks, dsSPEAK, ECAN, ECONOMONITOR, FanSense, HI-TIDE, In-Circuit Serial Programming, ICSP, Mindi, MiWi, MPASM, MPF, MPLAB Certified logo, MPLIB, MPLINK, mTouch, Omniscient Code Generation, PICC, PICC-18, PICDEM, PICDEM.net, PICKit, PICtail, REAL ICE, rLAB, Select Mode, SQL, Serial Quad I/O, Total Endurance, TSHARC, UniWinDriver, WiperLock, ZENA and Z-Scale are trademarks of Microchip Technology Incorporated in the U.S.A. and other countries.

SQTP is a service mark of Microchip Technology Incorporated in the U.S.A.

GestIC and ULPP are registered trademarks of Microchip Technology Germany II GmbH & Co. KG, a subsidiary of Microchip Technology Inc., in other countries.

All other trademarks mentioned herein are property of their respective companies.

© 2014, Microchip Technology Incorporated, Printed in the U.S.A., All Rights Reserved.

 Printed on recycled paper.

ISBN: 978-1-63276-174-3

**QUALITY MANAGEMENT SYSTEM**  
**CERTIFIED BY DNV**  
**== ISO/TS 16949 ==**

*Microchip received ISO/TS-16949:2009 certification for its worldwide headquarters, design and wafer fabrication facilities in Chandler and Tempe, Arizona; Gresham, Oregon and design centers in California and India. The Company's quality system processes and procedures are for its PIC® MCUs and dsPIC® DSCs, KEELOQ® code hopping devices, Serial EEPROMs, microperipherals, nonvolatile memory and analog products. In addition, Microchip's quality system for the design and manufacture of development systems is ISO 9001:2000 certified.*



# MICROCHIP

## Worldwide Sales and Service

### AMERICAS

**Corporate Office**  
2355 West Chandler Blvd.  
Chandler, AZ 85224-6199  
Tel: 480-792-7200  
Fax: 480-792-7277  
Technical Support:  
<http://www.microchip.com/support>  
Web Address:  
[www.microchip.com](http://www.microchip.com)

**Atlanta**  
Duluth, GA  
Tel: 678-957-9614  
Fax: 678-957-1455

**Austin, TX**  
Tel: 512-257-3370

**Boston**  
Westborough, MA  
Tel: 774-760-0087  
Fax: 774-760-0088

**Chicago**  
Itasca, IL  
Tel: 630-285-0071  
Fax: 630-285-0075

**Cleveland**  
Independence, OH  
Tel: 216-447-0464  
Fax: 216-447-0643

**Dallas**  
Addison, TX  
Tel: 972-818-7423  
Fax: 972-818-2924

**Detroit**  
Novi, MI  
Tel: 248-848-4000

**Houston, TX**  
Tel: 281-894-5983

**Indianapolis**  
Noblesville, IN  
Tel: 317-773-8323  
Fax: 317-773-5453

**Los Angeles**  
Mission Viejo, CA  
Tel: 949-462-9523  
Fax: 949-462-9608

**New York, NY**  
Tel: 631-435-6000

**San Jose, CA**  
Tel: 408-735-9110

**Canada - Toronto**  
Tel: 905-673-0699  
Fax: 905-673-6509

### ASIA/PACIFIC

**Asia Pacific Office**  
Suites 3707-14, 37th Floor  
Tower 6, The Gateway  
Harbour City, Kowloon  
Hong Kong  
Tel: 852-2943-5100  
Fax: 852-2401-3431

**Australia - Sydney**  
Tel: 61-2-9868-6733  
Fax: 61-2-9868-6755

**China - Beijing**  
Tel: 86-10-8569-7000  
Fax: 86-10-8528-2104

**China - Chengdu**  
Tel: 86-28-8665-5511  
Fax: 86-28-8665-7889

**China - Chongqing**  
Tel: 86-23-8980-9588  
Fax: 86-23-8980-9500

**China - Hangzhou**  
Tel: 86-571-8792-8115  
Fax: 86-571-8792-8116

**China - Hong Kong SAR**  
Tel: 852-2943-5100  
Fax: 852-2401-3431

**China - Nanjing**  
Tel: 86-25-8473-2460  
Fax: 86-25-8473-2470

**China - Qingdao**  
Tel: 86-532-8502-7355  
Fax: 86-532-8502-7205

**China - Shanghai**  
Tel: 86-21-5407-5533  
Fax: 86-21-5407-5066

**China - Shenyang**  
Tel: 86-24-2334-2829  
Fax: 86-24-2334-2393

**China - Shenzhen**  
Tel: 86-755-8864-2200  
Fax: 86-755-8203-1760

**China - Wuhan**  
Tel: 86-27-5980-5300  
Fax: 86-27-5980-5118

**China - Xian**  
Tel: 86-29-8833-7252  
Fax: 86-29-8833-7256

**China - Xiamen**  
Tel: 86-592-2388138  
Fax: 86-592-2388130

**China - Zhuhai**  
Tel: 86-756-3210040  
Fax: 86-756-3210049

### ASIA/PACIFIC

**India - Bangalore**  
Tel: 91-80-3090-4444  
Fax: 91-80-3090-4123

**India - New Delhi**  
Tel: 91-11-4160-8631  
Fax: 91-11-4160-8632

**India - Pune**  
Tel: 91-20-3019-1500

**Japan - Osaka**  
Tel: 81-6-6152-7160  
Fax: 81-6-6152-9310

**Japan - Tokyo**  
Tel: 81-3-6880-3770  
Fax: 81-3-6880-3771

**Korea - Daegu**  
Tel: 82-53-744-4301  
Fax: 82-53-744-4302

**Korea - Seoul**  
Tel: 82-2-554-7200  
Fax: 82-2-558-5932 or  
82-2-558-5934

**Malaysia - Kuala Lumpur**  
Tel: 60-3-6201-9857  
Fax: 60-3-6201-9859

**Malaysia - Penang**  
Tel: 60-4-227-8870  
Fax: 60-4-227-4068

**Philippines - Manila**  
Tel: 63-2-634-9065  
Fax: 63-2-634-9069

**Singapore**  
Tel: 65-6334-8870  
Fax: 65-6334-8850

**Taiwan - Hsin Chu**  
Tel: 886-3-5778-366  
Fax: 886-3-5770-955

**Taiwan - Kaohsiung**  
Tel: 886-7-213-7830

**Taiwan - Taipei**  
Tel: 886-2-2508-8600  
Fax: 886-2-2508-0102

**Thailand - Bangkok**  
Tel: 66-2-694-1351  
Fax: 66-2-694-1350

### EUROPE

**Austria - Wels**  
Tel: 43-7242-2244-39  
Fax: 43-7242-2244-393

**Denmark - Copenhagen**  
Tel: 45-4450-2828  
Fax: 45-4485-2829

**France - Paris**  
Tel: 33-1-69-53-63-20  
Fax: 33-1-69-30-90-79

**Germany - Dusseldorf**  
Tel: 49-2129-3766400

**Germany - Munich**  
Tel: 49-89-627-144-0  
Fax: 49-89-627-144-44

**Germany - Pforzheim**  
Tel: 49-7231-424750

**Italy - Milan**  
Tel: 39-0331-742611  
Fax: 39-0331-466781

**Italy - Venice**  
Tel: 39-049-7625286

**Netherlands - Drunen**  
Tel: 31-416-690399  
Fax: 31-416-690340

**Poland - Warsaw**  
Tel: 48-22-3325737

**Spain - Madrid**  
Tel: 34-91-708-08-90  
Fax: 34-91-708-08-91



**Sweden - Stockholm**  
Tel: 46-8-5090-4654

**UK - Wokingham**  
Tel: 44-118-921-5800  
Fax: 44-118-921-5820

03/25/14

## Looking for pricing, stock, or lifecycle information?

Click below to explore more details on WIN SOURCE:

-  [View PIC16F1769-I/SO on WIN SOURCE](#)
-  [Microchip Technology](#) Information

## Optimize Your Supply Chain with WIN SOURCE Solutions

-  Global Sourcing Solution
-  Obsolete Management
-  Cost Control Management
-  Shortage Management
-  Alternative Solution
-  Excess Inventory Management