



**16-Bit D-Type Flip-Flop  
with 3-State Outputs**

**Product Features**

- The PI74ALVTC Family is designed for low voltage operation,  $V_{DD} = 1.8V$  to  $3.6V$
- Supports Live Insertion
- 3.6V I/O Tolerant Inputs and Outputs
- Bus Hold
- High Drive,  $-32/64mA @ 3.3V$
- Uses patented Noise Reduction Circuitry
- Power-Off high impedance inputs and outputs
- Industrial operation at  $-40^{\circ}C$  to  $+85^{\circ}C$
- Packaging (Pb-free & Green available):  
-48-pin 240 mil wide plastic TSSOP (A)

**Product Description**

The PI74ALVTC16374 is particularly suitable for implementing buffer registers, I/O ports, bidirectional bus drivers, and working registers. This device can be used as two 8-bit flip-flops or one 16-bit flip-flop. On the positive transition of the clock (CLK) input, the Q outputs of the flip-flop take on the logic levels set up at the data (D) inputs.

A buffered Output Enable ( $\overline{OE}$ ) input can be used to place the eight outputs in either a normal logic state (high or low logic levels) or a high-impedance state in which the outputs neither load nor drive the bus lines significantly. The high-impedance state and the increased drive provide the capability to drive bus lines without need for interface or pullup components.  $\overline{OE}$  does not affect internal operations of the flip-flop. Old data can be retained or new data can be entered while the outputs are in the high-impedance state.

To ensure the high-impedance state during power up or power down,  $\overline{OE}$  should be tied to  $V_{DD}$  through a pullup resistor; whose minimum value is determined by the current-sinking capability of the driver.

The family offers both I/O Tolerant, which allows it to operate in mixed 1.8/3.6V systems, and "Bus Hold," which retains the data input's last state whenever the data input goes to high-impedance, preventing "floating" inputs and eliminating the need for pullup/down resistors.

**Logic Block Diagram**

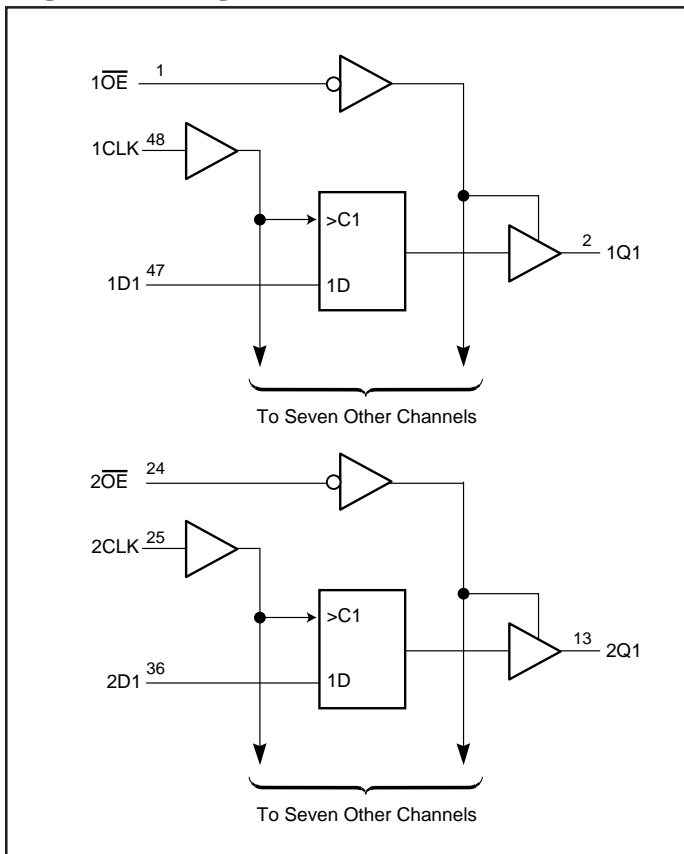

**Product Pin Description**

Pin Name	Description
$\overline{OE}$	Output Enable Input (Active LOW)
CLK	Clock Input
Dx	Data Inputs
Qx	3-State Outputs
GND	Ground
V <sub>DD</sub>	Power

**Truth Table<sup>(1)</sup>**

Inputs			Outputs
$\overline{OE}$	CLK	D	Q
L	↑	H	H
L	↑	L	L
L	H or L	X	Q <sub>0</sub>
H	X	X	Z

**Notes:**

- H = High Signal Level  
 L = Low Signal Level  
 X = Don't Care or Irrelevant  
 Z = High Impedance

**Product Pin Configuration**

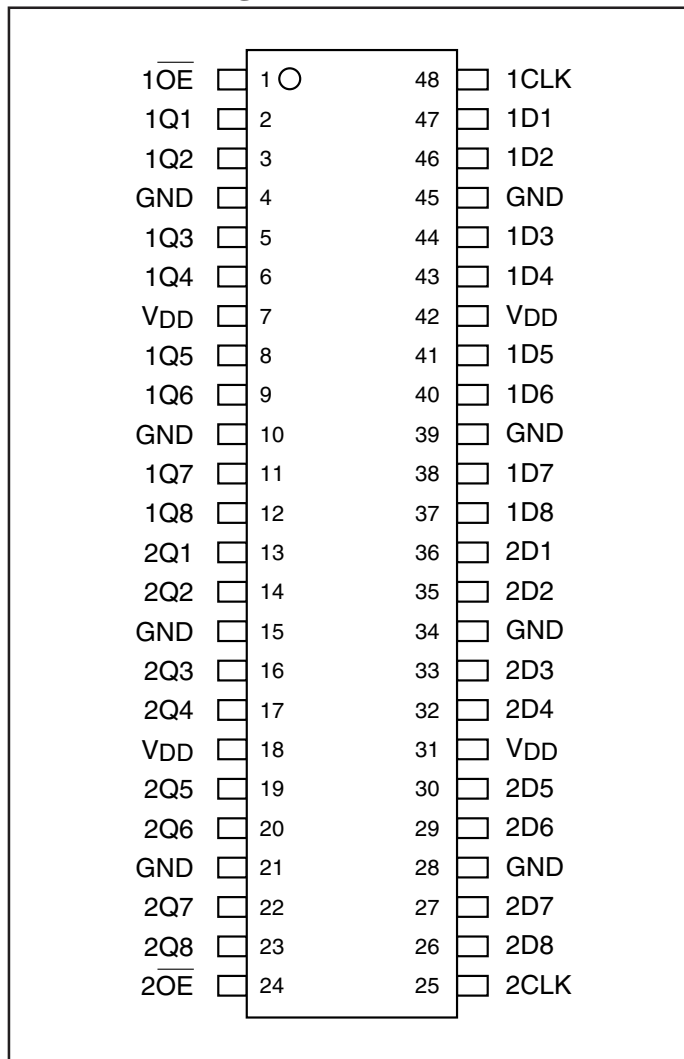

### Maximum Ratings

(Above which the useful life may be impaired. For user guidelines, not tested.)

Supply Voltage Range, $V_{DD}$ .....	-0.5V to 4.6V
Input Voltage Range, $V_I$ .....	-0.5V to 4.6V
Output Voltage Range, $V_O$ (3-States) .....	-0.5V to 4.6V
Output Voltage Range, $V_O^{(1)}$ (Active) .....	-0.5V to $V_{DD}+0.5V$
DC Input Diode Current ( $I_{IK}$ ) $V_I < 0V$ .....	-50mA
DC Output Diode Current ( $I_{OK}$ )	
$V_O < 0V$ .....	-50mA
$V_O > V_{DD}$ .....	$\pm 50mA$
DC $V_{DD}$ or GND Current per Supply Pin ( $I_{DD}$ or GND) .....	$\pm 100mA$
Storage Temperature Range, $T_{stg}$ .....	-65°C to 150°C

**Note:**

Stresses greater than those listed under MAXIMUM RATINGS may cause permanent damage to the device. This is a stress rating only and functional operation of the device at these or any other conditions above those indicated in the operational sections of this specification is not implied. Exposure to absolute maximum rating conditions for extended periods may affect reliability.

**Notes:**

1. Absolute maximum of  $I_O$  must be observed.

### Recommended Operating Conditions<sup>(1)</sup>

			Min.	Max.	Units
$V_{DD}$	Supply voltage	Operating	1.8	3.6	V
		Data Retention Only	1.2	3.6	
$V_{IH}$	High-level input voltage	$V_{DD} = 2.7V$ to $3.6V$	2.0		
$V_{IL}$	Low-level input voltage	$V_{DD} = 2.7V$ to $3.6V$		0.8	
$V_I$	Input voltage		-0.3	3.6	
$V_O$	Output voltage	Active State	0	$V_{DD}$	
		Off State	0	3.6	
	Output current in $I_{OH}/I_{OL}$	$V_{DD} = 3.0V$ to $3.6V$ $V_{DD} = 2.7V$ to $3.0V$ $V_{DD} = 2.3V$ to $2.7V$ $V_{DD} = 1.8V$		$\pm 32/64$ $\pm 24$ $\pm 18$ $\pm 6$	mA
$\Delta t/\Delta v$	Input transition rise or fall rate <sup>(2)</sup>		0	10	ns/V
$T_A$	Operating free-air temperature		-40	85	C

**Notes:**

1. Unused control inputs must be held HIGH or LOW to prevent them from floating.
2. As measured between 0.8V and 2.0V,  $V_{DD}=3.0V$ .

**Electrical Characteristics**

(Over Recommended Operating Free-Air Temperature Range, (unless otherwise noted).)

**DC Characteristics (2.7V <math>V\_{DD}</math> ≤ 3.6V)**

	Parameter	Conditions	$V_{DD}$	Min.	Typ.	Max.	Units
$V_{IH}$	HIGH Level Input Voltage		2.7 - 3.6	2.0			V
$V_{IL}$	LOW Level Input Voltage					0.8	
$V_{OH}$	HIGH Level Output Voltage	$I_{OH} = -100\mu A$		$V_{DD} - 0.2$			
		$I_{OH} = -12mA$	2.7	2.2			
		$I_{OH} = -18mA$	3.0	2.4			
		$I_{OH} = -24mA$		2.2			
		$I_{OH} = -32mA$		2.0			
$V_{OL}$	LOW Level Output Voltage	$I_{OL} = 100\mu A$	2.7 - 3.6			0.2	
		$I_{OL} = 12mA$	2.7			0.4	
		$I_{OL} = 18mA$	3.0			0.4	
		$I_{OL} = 24mA$				0.45	
		$I_{OL} = 32mA$				0.5	
		$I_{OL} = 64mA$				0.55	
$I_I$	Input Leakage Current	$V_I = V_{DD}$ , or GND	3.6			±5.0	μA
$I_{OZ}$	3-State Output Leakage	$V_O = 3.6V$	2.7			±10	
$I_{OFF}$	Power-OFF Leakage Current	$V_I$ or $V_O \leq 3.6V$	0			10	
$I_{ODL}$	Output Current Low	$V_{IN} = V_{IH}$ or $V_{IL}$ , $V_O = 1.5V^{(1)}$	3.6	150		334	mA
$I_{ODH}$	Output Current High	$V_{IN} = V_{IH}$ or $V_{IL}$ , $V_O = 1.5V^{(1)}$		-58		-114	
$I_{HOLD}$	Bus Hold Current A or B Outputs	$V_I = 0.8V$	3.0	75			μA
		$V_I = 2.0V$		-75			
		$V_I = 0$ to 3.6V	3.6			±500	
$I_{DD}$	Quiescent Supply Current	$V_I = V_{DD}$ or GND	2.7 - 3.6			50	
		$V_{DD} \leq (V_I, V_O) \leq 3.6V$				±50	
$\Delta I_{DD}$	Increase in $I_{DD}$ per input	$V_{IH} = V_{DD} - 0.6V$ , Other inputs at $V_{DD}$ or GND					

**Notes:**

1. Duration of test must not exceed 1 second with only 1 output tested at a time.

**Electrical Characteristics**

(Over Recommended Operating Free-Air Temperature Range (unless otherwise noted).)

**DC Characteristics (2.3V <math>V\_{DD}</math> ≤ 2.7V)**

Description	Parameters	Conditions	$V_{DD}$	Min.	Typ.	Max.	Units
$V_{IH}$	HIGH Level Input Voltage		2.3 - 2.7	1.6			V
$V_{IL}$	LOW Level Input Voltage					0.7	
$V_{OH}$	HIGH Level Output Voltage	$I_{OH} = -100\mu A$			$V_{DD} - 0.2$		
		$I_{OH} = -12mA$	2.3	1.8			
		$I_{OH} = -18mA$		1.7			
$V_{OL}$	LOW Level Output Voltage	$I_{OL} = 100\mu A$	2.3 - 2.7			0.2	
		$I_{OL} = 12mA$	2.3			0.4	
		$I_{OL} = 18mA$				0.5	
		$I_{OL} = 24mA$				0.55	
$I_I$	Input Leakage Current	$V_I = V_{DD}$ or GND	2.7			±5.0	$\mu A$
$I_{OZ}$	3-State Output Leakage	$V_O = 3.6V$	2.3			±10	
$I_{OFF}$	Power-OFF Leakage Current	$V_I$ or $V_O \leq 3.6V$	0			10	
$I_{ODL}$	Output Current Low	$V_{IN} = V_{IH}$ or $V_{IL}$ , $V_O = 1.5V^{(2)}$	2.7	110		264	mA
$I_{ODH}$	Output Current High	$V_{IN} = V_{IH}$ or $V_{IL}$ , $V_O = 1.5V^{(2)}$		-30		-60	
$I_{HOLD}^{(1)}$	Bus Hold Current A or B Outputs	$V_I = 0.7V$	2.5		90		$\mu A$
		$V_I = 1.7V$			-90		
$I_{DD}$	Quiescent Supply Current	$V_I = V_{DD}$ or GND	2.3 - 2.7			40	
		$V_{DD} \leq (V_I, V_O) \leq 3.6V$				±40	
$\Delta I_{DD}$	Increase in $I_{DD}$ per input	$V_{IH} = V_{DD} - 0.6V$ , Inputs at $V_{DD}$ or GND					

**Notes:**

1. Not guaranteed.
2. Duration of test must not exceed 1 second with only 1 output tested at a time.

**Electrical Characteristics**

(Over Recommended Operating Free-Air Temperature Range (unless otherwise noted).)

**DC Characteristics (1.8V <math>V\_{DD}</math> ≤ 2.3V)**

Description	Parameters	Conditions	$V_{DD}$	Min.	Typ.	Max.	Units	
$V_{IH}$	HIGH Level Input Voltage		1.8-2.3	$0.7 \times V_{DD}$			V	
$V_{IL}$	LOW Level Input Voltage					$0.2 \times V_{DD}$		
$V_{OH}$	HIGH Level Output Voltage	$I_{OH} = -100\mu A$	1.8	$V_{DD} - 0.2$				
		$I_{OH} = -6mA$		1.4				
$V_{OL}$	LOW Level Output Voltage	$I_{OL} = 100\mu A$						0.2
		$I_{OL} = 6mA$						0.3
$I_I$	Input Leakage Current	$V_I = V_{DD}$ or GND	2.3			±5.0	μA	
$I_{OZ}$	3-State Output Leakage	$V_O = 3.6V$	1.8			±10		
$I_{OFF}$	Power-OFF Leakage Current	$V_I = V_O \leq 3.6V$	0			10		
$I_{ODL}$	Output Current Low	$V_{IN} = V_{IH}$ or $V_{IL}$ , $V_O = 0.9V^{(2)}$	1.8	50		137	mA	
$I_{ODH}$	Output Current High	$V_{IN} = V_{IH}$ or $V_{IL}$ , $V_O = 0.9V^{(2)}$		-14		-34		
$I_{HOLD}^{(1)}$	Bus Hold Current A or B Outputs	$V_I = 0.4$	1.8		50		μA	
		$V_I = 1.3$			-50			
$I_{DD}$	Quiescent Supply Current	$V_I = V_{DD}$ or GND						20
		$V_{DD} \leq (V_I, V_O) \leq 3.6V$						±20
$\Delta I_{DD}$	Increase in $I_{DD}$ per input	$V_I = V_{DD} - 0.6V$ , Other inputs at $V_{DD}$ or GND				400		

**Notes:**

1. Not guaranteed.
2. Duration of test must not exceed 1 second with only 1 output tested at a time.

**AC Electrical Characteristics**

Symbol	Parameter	$T_A = -40^\circ\text{C to } +85^\circ\text{C}, C_L = 50\text{pF}, R_L = 500\Omega$						Units
		$V_{DD} = 3.3\text{V} \pm 0.3\text{V}$		$V_{DD} = 2.5\text{V} \pm 0.2\text{V}$		$V_{DD} = 1.8\text{V}$		
		Min.	Max.	Min.	Max.	Min.	Max.	
$f_{MAX}$	Maximum Clock Frequency	250		250		250		MHz
$t_{PLH}, t_{PHL}$	Prop Delay, CLK to Q	1.0	3.2	1.5	4.2	1.5	4.8	ns
$t_{PZH}, t_{PZL}$	Output Enable Time	1.0	3.2	1.0	4.7	1.5	5.0	
$t_{PHZ}, t_{PLZ}$	Output Disable Time	1.0	3.4	1.0	3.8	1.5	4.0	
$t_{OSHL}, t_{OSLH}$	Output to Output Skew <sup>(1)</sup>		0.5		0.5		0.5	

**Notes:**

1. Skew is defined as the absolute value of the difference between the actual propagation delay for any two separate outputs of the same device. The specification applies to any outputs switching in the same direction, either HIGH or LOW ( $t_{OSHL}$ ) or LOW to HIGH ( $t_{OSLH}$ ).

**AC Setup Requirements**

Symbol	Parameter	$T_A = -40^\circ\text{C to } +85^\circ\text{C}, C_L = 50\text{pF}, R_L = 500\Omega$						Units
		$V_{DD} = 3.3\text{V} \pm 0.3\text{V}$		$V_{DD} = 2.5\text{V} \pm 0.2\text{V}$		$V_{DD} = 1.8\text{V}$		
		Min.	Typ.	Min.	Typ.	Min.	Typ.	
$t_{SU}$	Setup Time	1.0		1.0		1.0		ns
$t_H$	Hold Time	0.5		0.5		1.0		
$t_W$	Pulse Width	1.5		1.5		1.5		

**Capacitance**

Symbol	Parameter	Conditions	$T_A = +25^\circ\text{C}$ Typical	Units
$C_{IN}$	Input Capacitance	$V_{DD} = 1.8, 2.5\text{V or } 3.3\text{V}, V_I = 0\text{V or } V_{DD}$	6	pF
$C_{OUT}$	Output Capacitance	$V_I = 0\text{V or } V_{DD}, V_{DD} = 1.8\text{V}, 2.5\text{V or } 3.3\text{V}$	7	
$C_{PD}$	Power Dissipation Capacitance	$V_I = 0\text{V or } V_{DD}, F = 10\text{ MHz}$ $V_{DD} = 1.8\text{V}, 2.5\text{V or } 3.3\text{V}$	20	

### Test Circuits and Switching Waveforms

Parameter Measurement Information ( $V_{DD} = 1.8V - 3.6V$ )

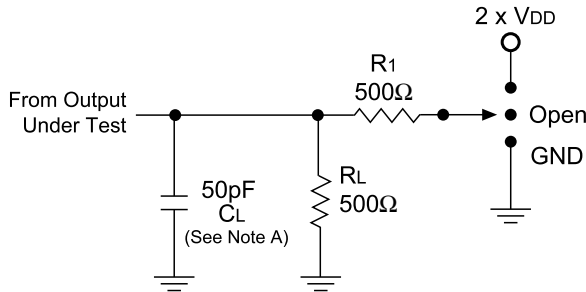

### Switch Position

Test	S1
$t_{PD}$	Open
$t_{PLZ}/t_{PZL}$	$2 \times V_{DD}$
$t_{PHZ}/t_{PZH}$	GND

### Setup, Hold, and Release Timing

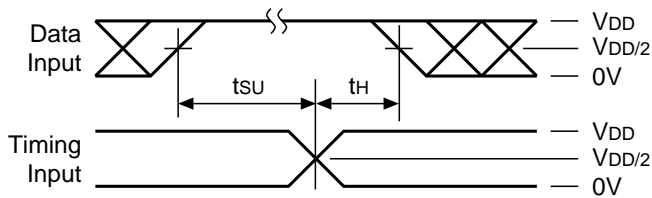

#### Notes:

- $C_L$  includes probe and jig capacitance.
- Waveform 1 is for an output with internal conditions such that the output is LOW except when disabled by the output control.  
Waveform 2 is for an output with internal conditions such that the output is HIGH except when disabled by the output control.
- All input pulses are supplied by generators having the following characteristics:  $PRR \leq 10 \text{ MHz}$ ,  $Z_O = 50\Omega$ ,  $t_r \leq 2\text{ns}$ ,  $t_f \leq 2\text{ns}$ , **measured from 10% to 90%, unless otherwise specified.**
- The outputs are measured one at a time with one transition per measurement.

### Pulse Width

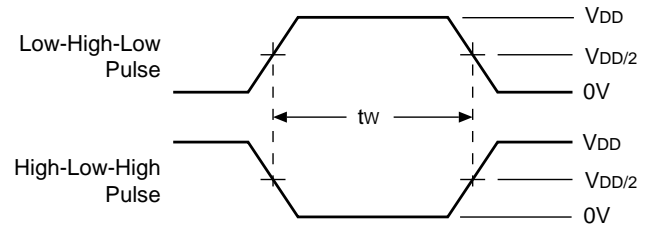

### Propagation Delay

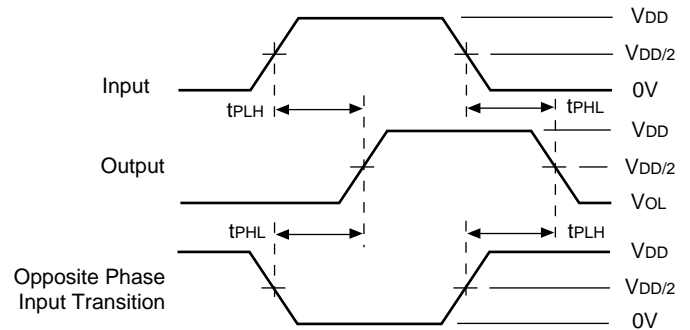

### Enable Disable Timing

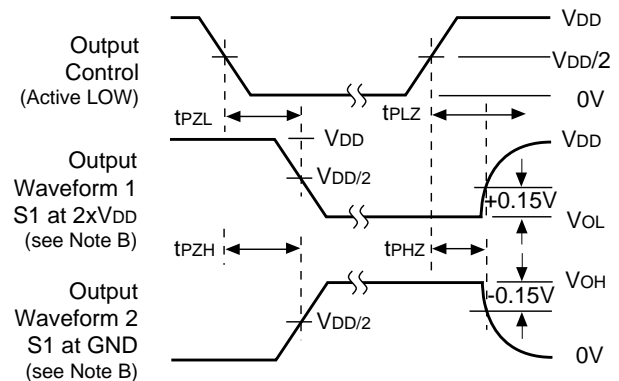

**Packaging Mechanical: 48-pin TSSOP (A)**

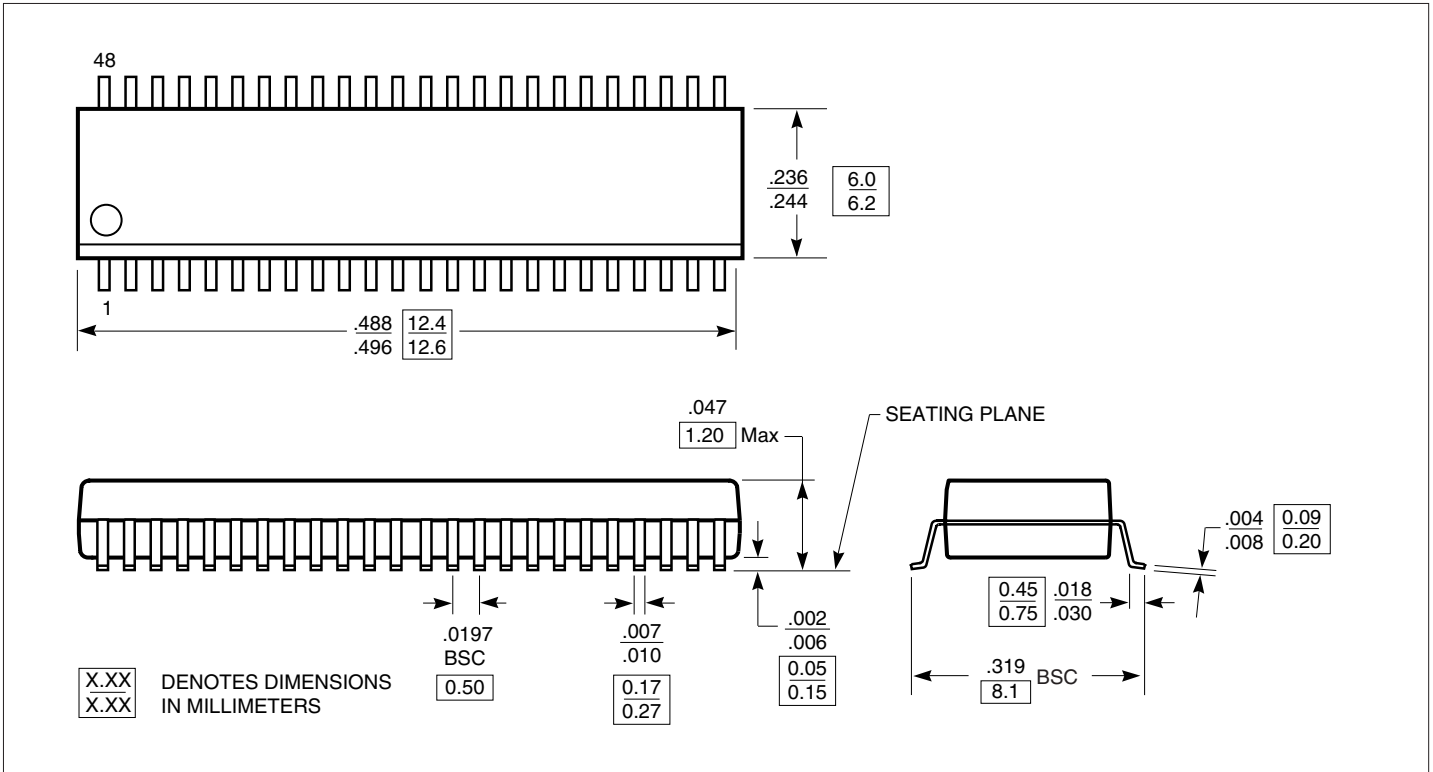

**Ordering Information**



Ordering Code	Package Code	Package Type
PI74ALVTC16374AE	A	Pb-free & Green, 48-pin 240-mil wide TSSOP

**Notes:**

- Thermal characteristics can be found on the company web site at [www.pericom.com/packaging/](http://www.pericom.com/packaging/)
- E = Pb-free & Green
- Adding an X suffix = Tape/Reel

## Looking for pricing, stock, or lifecycle information?

Click below to explore more details on WIN SOURCE:

-  [View PI74ALVTC16374A on WIN SOURCE](#)
-  [Diodes Incorporated Information](#)

## Optimize Your Supply Chain with WIN SOURCE Solutions

-  Global Sourcing Solution
-  Obsolete Management
-  Cost Control Management
-  Shortage Management
-  Alternative Solution
-  Excess Inventory Management