



**THE DATASHEET OF
PI6C4931504-04LIEX**



PI6C4931504-04

High Performance HCSL Fanout Buffer

Features

- 4 HCSL outputs
- Up to 250MHz output frequency
- Ultra low additive phase jitter: < 0.1 ps (typ)
- Two selectable inputs
- Low delay from input to output (Tpd typ. 1.5ns)
- 2.5V / 3.3V power supply
- Industrial temperature support
- Totally Lead-Free & Fully RoHS Compliant (Notes 1 & 2)
- Halogen and Antimony Free. “Green” Device (Note 3)
- TSSOP-20 package

Description

The PI6C4931504-04 is a high performance fanout buffer device which supports up to 250MHz frequency. This device is ideal for systems that need to distribute low jitter clock signals to multiple destinations.

Applications

- Networking systems including switches and Routers
- High frequency backplane based computing and telecom platforms

Block Diagram

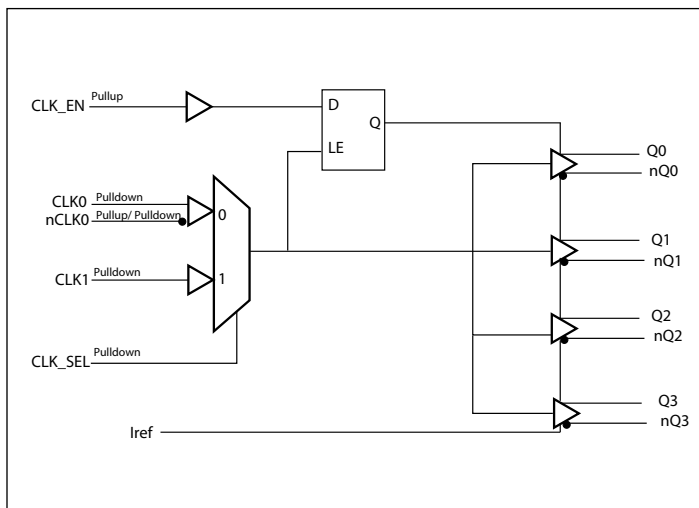

Pin Configuration (20-Pin TSSOP)

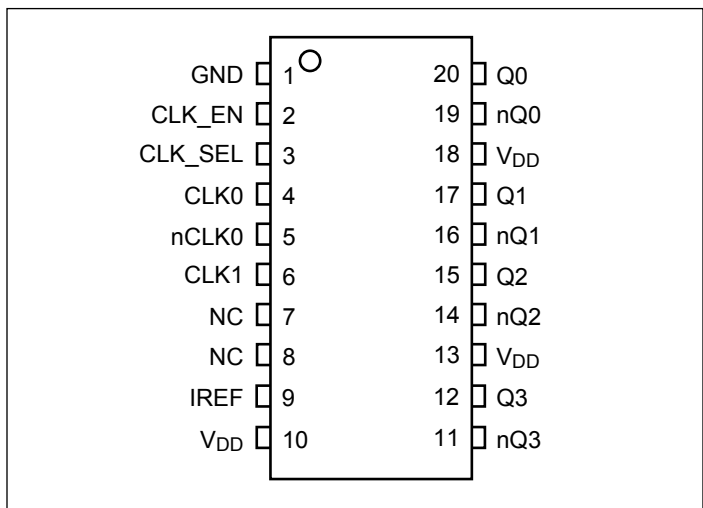

Notes:

1. No purposely added lead. Fully EU Directive 2002/95/EC (RoHS), 2011/65/EU (RoHS 2) & 2015/863/EU (RoHS 3) compliant.
2. See <https://www.diodes.com/quality/lead-free/> for more information about Diodes Incorporated’s definitions of Halogen- and Antimony-free, “Green” and Lead-free.
3. Halogen- and Antimony-free “Green” products are defined as those which contain <900ppm bromine, <900ppm chlorine (<1500ppm total Br + Cl) and <1000ppm antimony compounds.

Pin Description

Pin #	Pin Name	Type	Description
1	GND	Power	Ground
2	CLK_EN	Input	Clock output enable/ disable
3	CLK_SEL	Input	Clock input source selection pin
4, 5	CLK0 nCLK0	Input	Clock input
6	CLK1	Input	Clock input
7, 8	NC	-	No connect
9	IREF	Power	External resistor connection to set differential output current
10, 13, 18	V _{DD}	Power	Power supply
11, 12	nQ3 Q3	Output	HCSL output clock
14, 15	nQ2 Q2	Output	HCSL output clock
16, 17	nQ1 Q1	Output	HCSL output clock
19, 20	nQ0 Q0	Output	HCSL output clock

Function Table

Table 1: Input select function

CLK_SEL	Function
0	CLK0, nCLK0
1	CLK1

Table 2: Output Enable function

CLK_EN	Outputs	
	Q0:Q4	nQ0:nQ4
0	Disabled; LOW	Disabled; HIGH
1	Enabled	Enabled

Maximum Ratings (Above which the useful life may be impaired. For user guidelines, not tested)

Storage temperature.....	-55 to +150°C
Supply Voltage to Ground Potential (V_{DD}).....	-0.5 to +4.6V
Inputs (Referenced to GND)	-0.5 to $V_{DD}+0.5V$
Clock Output (Referenced to GND).....	-0.5 to $V_{DD}+0.5V$
Soldering Temperature (Max of 10 seconds)	+260°C

Note:

Stresses greater than those listed under MAXIMUM RATINGS may cause permanent damage to the device. This is a stress rating only and functional operation of the device at these or any other conditions above those indicated in the operational sections of this specification is not implied. Exposure to absolute maximum rating conditions for extended periods may affect reliability.

Power Supply Characteristics and Operating Conditions

Symbol	Parameter	Test Condition	Min.	Typ.	Max.	Units
V_{DD}	Core Supply Voltage		2.97		3.63	V
			2.375		2.625	V
I_{DD}	Power Supply Current	$V_{DD} = 3.3V$, Unloaded			90	mA
		$V_{DD} = 2.5V$, Unloaded			80	
T_A	Ambient Operating Temperature		-40		85	°C

DC Electrical Specifications - Differential Inputs

Symbol	Parameter		Min.	Typ.	Max.	Units
I_{IH}	Input High current: CLK0, nCLK0	Input = V_{DD}			200	uA
I_{IL}	Input Low current: nCLK0		-200			uA
	Input Low current: CLK0		-10			uA
C_{IN}	Input capacitance			4		PF
V_{IH}	Input high voltage				$V_{DD}+0.3$	V
V_{IL}	Input low voltage		-0.3			V
V_{ID}	Input Differential Amplitude PK-PK		150		1300	mV
V_{CM}	Common mode input voltage		GND + 0.5		$V_{DD}-0.85$	V

DC Electrical Specifications - LVCMOS Inputs

Symbol	Parameter		Conditions	Min.	Typ.	Max.	Units
I _{IH}	Input High current	CLK1, CLK_SEL	Input = V _{DD}			200	uA
		CLK_EN				20	uA
I _{IL}	Input Low current	CLK1, CLK_SEL	Input = GND	-10			uA
		CLK_EN		-200			uA
V _{IH}	Input high voltage		V _{DD} =3.3V	2.0		3.765	V
V _{IL}	Input low voltage		V _{DD} =3.3V	-0.3		0.8	V
V _{IH}	Input high voltage		V _{DD} =2.5V	1.7		2.8	V
V _{IL}	Input low voltage		V _{DD} =2.5V	-0.3		0.7	V

DC Electrical Specifications – HCSL Outputs

Parameter	Description	Conditions	Min.	Typ.	Max.	Units
V _{OH}	Output High voltage	V _{DD} =3.3V	520	800		mV
V _{OL}	Output Low voltage	V _{DD} =3.3V		0	150	mV

AC Electrical Specifications – Differential Outputs

Parameter	Description	Conditions	Min.	Typ.	Max.	Units
f _{OUT}	Output frequency				250	MHz
T _r	Output rise time	From 20% to 80%	175		700	ps
T _f	Output fall time	From 80% to 20%	175		700	ps
T _{ODC}	Output duty cycle		48		52	%
T _j	Buffer additive jitter RMS			0.1		ps
V _{MAX}	Absolute Maximum Output Voltage				1150	mV
V _{MIN}	Absolute Minimum Output Voltage		-300			mV
V _{CROSS}	Absolute crossing voltage	HCSL	250		550	mV
DV _{CROSS}	Total variation of crossing voltage	HCSL			140	mV
T _{SK}	Output Skew			40	100	ps
T _{PD}	Propagation Delay			1500		ps
T _{P2P Skew}	Part to Part Skew ¹				600	ps

Notes:

1. This parameter is guaranteed by design

PI6C4931504-04

Configuration test load board termination for HCSL Outputs

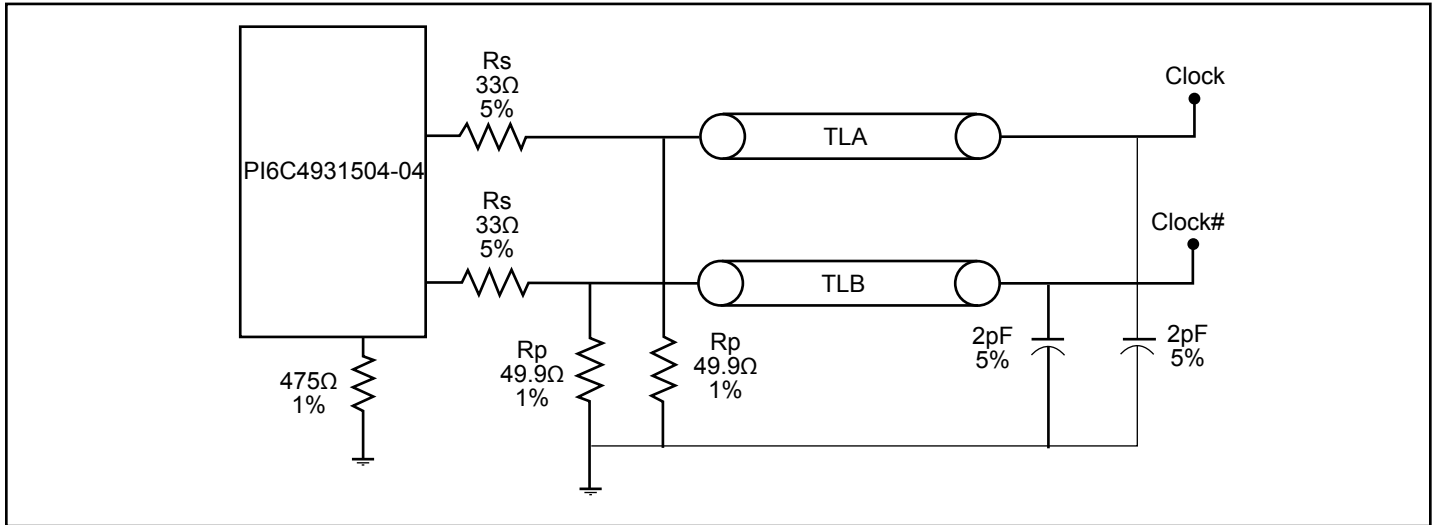

Part Marking

L Package

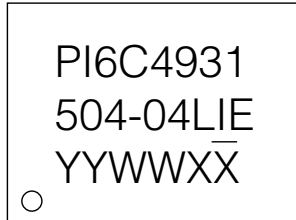

YY: Year

WW: Workweek

1st X: Assembly Code

2nd X: Fab Code

Packaging Mechanical: 20-TSSOP (L)

SYMBOLS	MIN.	NOM.	MAX.
A	–	–	1.20
A1	0.05	–	0.15
A2	0.80	1.00	1.05
b	0.19	–	0.30
C	0.09	–	0.20
D	6.40	6.50	6.60
E1	4.30	4.40	4.50
E	6.20	6.40	6.60
e	0.65 BSC		
L1	1.00 REF		
L	0.45	0.60	0.75
S	0.20	–	–
θ	0°	–	8°

NOTES:
 1. ALL DIMENSIONS IN MILLIMETERS. ANGLES IN DEGREES.
 2. JEDEC MO-153F
 3. DIMENSIONS DOES NOT INCLUDE MOLD FLASH, PROTRUSIONS OR GATE BURRS.

16-0074

		DATE: 03/31/16
DESCRIPTION: 20-Pin, 173mil Wide TSSOP		
PACKAGE CODE: L (L20)		
DOCUMENT CONTROL #: PD-1311	REVISION: G	

For latest package info.

please check: <http://www.diodes.com/design/support/packaging/pericom-packaging/packaging-mechanicals-and-thermal-characteristics/>

Ordering Information⁽¹⁻³⁾

Ordering Code	Package Code	Package Description
PI6C4931504-04LIEX	L	20-pin, 173mil Wide (TSSOP)

Notes:

1. No purposely added lead. Fully EU Directive 2002/95/EC (RoHS), 2011/65/EU (RoHS 2) & 2015/863/EU (RoHS 3) compliant.
2. See <https://www.diodes.com/quality/lead-free/> for more information about Diodes Incorporated's definitions of Halogen- and Antimony-free, "Green" and Lead-free.
3. Halogen- and Antimony-free "Green" products are defined as those which contain <900ppm bromine, <900ppm chlorine (<1500ppm total Br + Cl) and <1000ppm antimony compounds.
4. E = Pb-free and Green
5. X suffix = Tape/Reel

IMPORTANT NOTICE

DIODES INCORPORATED MAKES NO WARRANTY OF ANY KIND, EXPRESS OR IMPLIED, WITH REGARDS TO THIS DOCUMENT, INCLUDING, BUT NOT LIMITED TO, THE IMPLIED WARRANTIES OF MERCHANTABILITY AND FITNESS FOR A PARTICULAR PURPOSE (AND THEIR EQUIVALENTS UNDER THE LAWS OF ANY JURISDICTION).

Diodes Incorporated and its subsidiaries reserve the right to make modifications, enhancements, improvements, corrections or other changes without further notice to this document and any product described herein. Diodes Incorporated does not assume any liability arising out of the application or use of this document or any product described herein; neither does Diodes Incorporated convey any license under its patent or trademark rights, nor the rights of others. Any Customer or user of this document or products described herein in such applications shall assume all risks of such use and will agree to hold Diodes Incorporated and all the companies whose products are represented on Diodes Incorporated website, harmless against all damages.

Diodes Incorporated does not warrant or accept any liability whatsoever in respect of any products purchased through unauthorized sales channel.

Should Customers purchase or use Diodes Incorporated products for any unintended or unauthorized application, Customers shall indemnify and hold Diodes Incorporated and its representatives harmless against all claims, damages, expenses, and attorney fees arising out of, directly or indirectly, any claim of personal injury or death associated with such unintended or unauthorized application.

Products described herein may be covered by one or more United States, international or foreign patents pending. Product names and markings noted herein may also be covered by one or more United States, international or foreign trademarks.

This document is written in English but may be translated into multiple languages for reference. Only the English version of this document is the final and definitive format released by Diodes Incorporated.

LIFE SUPPORT

Diodes Incorporated products are specifically not authorized for use as critical components in life support devices or systems without the express written approval of the Chief Executive Officer of Diodes Incorporated. As used herein:

A. Life support devices or systems are devices or systems which:

1. are intended to implant into the body, or

2. support or sustain life and whose failure to perform when properly used in accordance with instructions for use provided in the labeling can be reasonably expected to result in significant injury to the user.

B. A critical component is any component in a life support device or system whose failure to perform can be reasonably expected to cause the failure of the life support device or to affect its safety or effectiveness.



Customers represent that they have all necessary expertise in the safety and regulatory ramifications of their life support devices or systems, and acknowledge and agree that they are solely responsible for all legal, regulatory and safety-related requirements concerning their products and any use of Diodes Incorporated products in such safety-critical, life support devices or systems, notwithstanding any devices- or systems-related information or support that may be provided by Diodes Incorporated. Further, Customers must fully indemnify Diodes Incorporated and its representatives against any damages arising out of the use of Diodes Incorporated products in such safety-critical, life support devices or systems.

Copyright © 2016, Diodes Incorporated

www.diodes.com

Looking for pricing, stock, or lifecycle information?

Click below to explore more details on WIN SOURCE:

-  [View PI6C4931504-04LIEX on WIN SOURCE](#)
-  [Diodes Incorporated Information](#)

Optimize Your Supply Chain with WIN SOURCE Solutions

-  Global Sourcing Solution
-  Obsolete Management
-  Cost Control Management
-  Shortage Management
-  Alternative Solution
-  Excess Inventory Management