



**THE DATASHEET OF
PI49FCT807BTSE**



Features

- Guaranteed low skew: 0.25ns
- Low input capacitance
- Minimum duty cycle distortion
- 1:10 fanout
- High speed: 3.5ns propagation delay
- TTL input and CMOS output compatible
 - $V_{OH} = 3.3V$ (typ.)
 - $V_{OL} = 0.3V$ (typ.)
- Industrial Operation at $-40^{\circ}C$ to $+85^{\circ}C$
- Packaging (Pb-free & Green available):
 - 20-pin 300-mil wide SOIC (S)
 - 20-pin 150-mil wide QSOP (Q)
 - 20-pin 209-mil wide SSOP (H)

Description

Pericom Semiconductor’s PI49FCT807T and PI49FCT2807T clock drivers feature one input and ten outputs. The large fanout from a single input line reduces loading on input clock. TTL level outputs reduce noise levels on the part. Typical applications are clock and signal distribution.

The PI49FCT2807T also features a 25-ohm on-chip resistor for lower noise.

Pin Configuration

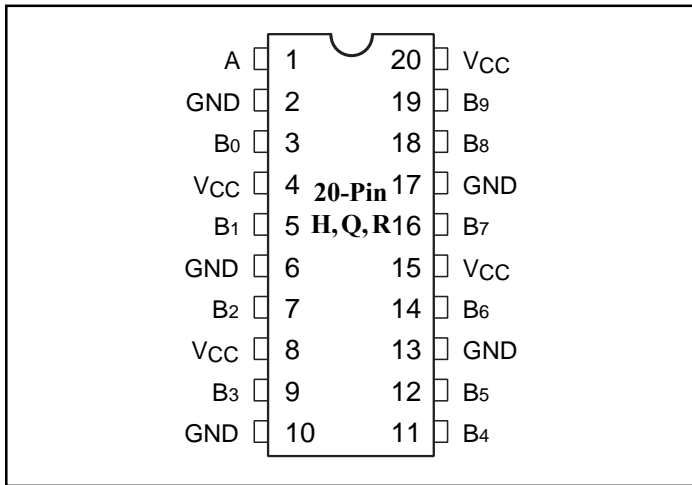

Pin Description

Pin Name	Description
A	Input
B0 – B9	Outputs
GND	Ground
V _{CC}	Power

Block Diagram

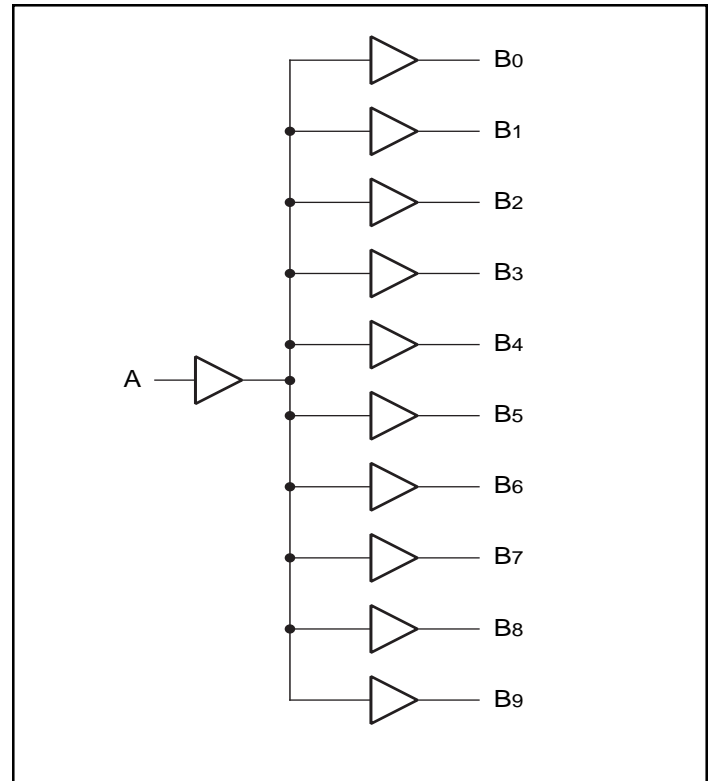

Maximum Ratings

(Above which the useful life may be impaired. For user guidelines, not tested.)

Storage Temperature	-65°C to +150°C
Ambient Temperature with Power Applied	-40°C to +85°C
Supply Voltage to Ground Potential (Inputs & Vcc Only)	-0.5V to +7.0V
Supply Voltage to Ground Potential (Outputs & D/O Only) ..	-0.5V to +7.0V
DC Input Voltage	-0.5V to +7.0V
DC Output Current	120mA
Power Dissipation	0.5W

Note:

Stresses greater than those listed under MAXIMUM RATINGS may cause permanent damage to the device. This is a stress rating only and functional operation of the device at these or any other conditions above those indicated in the operational sections of this specification is not implied. Exposure to absolute maximum rating conditions for extended periods may affect reliability.

DC Electrical Characteristics (Over the Operating Range, $T_A = -40^\circ\text{C}$ to $+85^\circ\text{C}$, $V_{CC} = 5.0\text{V} \pm 5\%$)

Parameters	Description	Test Conditions ⁽¹⁾		Min.	Typ. ⁽²⁾	Max.	Units
V _{OH}	Output HIGH Voltage	V _{CC} = Min., V _{IN} = V _{IH} or V _{IL}	I _{OH} = -15.0mA	2.4	3.3		V
			I _{OH} = 48.0mA		0.2	0.5	V
V _{OL}	Output LOW Current	V _{CC} = Min., V _{IN} = V _{IH} or V _{IL}	I _{OL} = 12mA(25Ω)		0.2	0.5	V
V _{IH}	Input HIGH Voltage	Guaranteed Logic HIGH Level		2.0			V
V _{IL}	Input LOW Voltage	Guaranteed Logic LOW Level				0.8	V
I _{IH}	Input HIGH Current	V _{CC} = Max.	V _{IN} = 2.7V			1	μA
I _{IL}	Input LOW Current	V _{CC} = Max.	V _{IN} = 0.5V			-1	μA
I _I	Input HIGH Current	V _{CC} = Max., V _{IN} = V _{CC} (Max.)				20	μA
V _{IK}	Clamp Diode Voltage	V _{CC} = Min., I _{IN} = -18mA			-0.7	-1.2	V
I _{OS}	Short Circuit Current	V _{CC} = Max. ⁽³⁾ , V _{OUT} = GND		-60	-120	-225	mA
I _{OFF}	Power Down Disable	V _{CC} = GND, V _{OUT} = 4.5V		—	—	100	μA
V _H	Input Hysteresis				150		mV

Capacitance ($T_A = 25^\circ\text{C}$, $f = 1\text{ MHz}$)

Parameters ⁽⁴⁾	Description	Test Conditions	Typ.	Max.	Units
C _{IN}	Input Capacitance	V _{IN} = 0V	6.0	10	pF
C _{OUT}	Output Capacitance	V _{OUT} = 0V	8	12	pF

Notes:

1. For Max. or Min. conditions, use appropriate value specified under Electrical Characteristics for the applicable device type.
2. Typical values are at Vcc = 5.0V, +25°C ambient and maximum loading.
3. Not more than one output should be shorted at one time. Duration of the test should not exceed one second.
4. This parameter is determined by device characterization but is not production tested.

Power Supply Characteristics

Parameters	Description	Test Conditions ⁽¹⁾		Min.	Typ. ⁽²⁾	Max.	Units
ICC	Quiescent Power Supply Current	V _{CC} = Max.	V _{IN} = GND or V _{CC}		3	30	μA
ΔICC	Supply Current per Input @ TTL HIGH	V _{CC} = Max.,	V _{IN} = 3.4V ⁽³⁾		0.5	1.5	mA
ICCD	Supply Current per Input per MHz ⁽⁴⁾	V _{CC} = Max., Outputs Open 50% Duty Cycle, One Input Toggling	V _{IN} = V _{CC} V _{IN} = GND		0.4	0.6	mA/ MHz
IC	Total Power Supply Current ⁽⁶⁾	V _{CC} = Max., Outputs Open f _{CP} = 50 MHz, 50% Duty Cycle	V _{IN} = V _{CC} V _{IN} = GND		20	30 ⁽⁵⁾	mA
			V _{IN} = 3.4V V _{IN} = GND		20.7	33 ⁽⁵⁾	

Notes:

- For Max. or Min. conditions, use appropriate value specified under Electrical Characteristics for the applicable device.
- Typical values are at V_{CC} = 5.0V, +25°C ambient.
- Per TTL driven input (V_{IN} = 3.4V); all other inputs at V_{CC} or GND.
- This parameter is not directly testable, but is derived for use in Total Power Supply Calculations.
- Values for these conditions are examples of the I_{CC} formula. These limits are guaranteed but not tested.
- IC = I_{QUIESCENT} + I_{INPUTS} + I_{DYNAMIC}
 IC = ICC + ΔICC_{DHNT} + ICCD (f_{CP}/2 + f_iN_i)
 ICC = Quiescent Current
 ΔICC = Power Supply Current for a TTL High Input (V_{IN} = 3.4V)
 DH = Duty Cycle for TTL Inputs High
 NT = Number of TTL Inputs at DH
 ICCD = Dynamic Current Caused by an Input Transition Pair (HLH or LHL)
 f_{CP} = Clock Frequency for Register Devices (Zero for Non-Register Devices)
 f_i = Input Frequency
 N_i = Number of Inputs at f_i
 All currents are in milliamps and all frequencies are in megahertz.

Switching Characteristics over Operating Range

Parameters	Description	Conditions ⁽¹⁾	807/2807T		807AT		807BT		807CT		Units
			Com.		Com.		Com.		Com.		
			Min.	Max.	Min.	Max.	Min.	Max.	Min.	Max.	
t _{PLH}	Propagation Delay	C _L = 50pF R _L = 500Ω	1.5	4.5	1.5	4.0	1.5	3.8	1.5	3.5	ns
t _{PHL}	A TO B _N										
t _{SK(o)}	Skew between two outputs of same package ⁽³⁾		—	0.5	—	0.5	—	0.35	—	0.25	ns
t _{SK(p)}	Skew between opposite transitions of same output (t _{PHL} - t _{PLH}) ⁽³⁾		—	0.5	—	0.5	—	0.35	—	0.35	ns
t _{SK(i)}	Skew between outputs of different package at same power supply, temperature and speed grade ⁽³⁾		—	1.0	—	1.0	—	0.75	—	0.75	ns

Notes:

- See test circuit and wave forms.
- Minimum limits are guaranteed but not tested on Propagation Delays.
- This parameter is guaranteed but not tested.

Tests Circuits For All Outputs⁽¹⁾

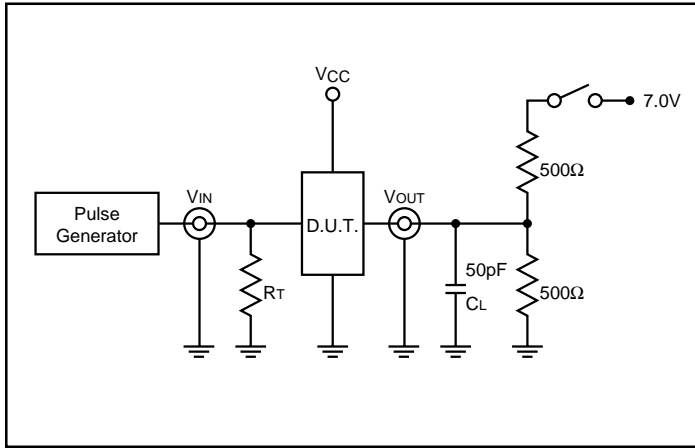

Switch Position

Test	Switch
Open Drain Disable LOW Enable LOW	Closed
All Other Inputs	Open

Definitions:

C_L = Load capacitance: includes jig and probe capacitance.

R_T = Termination resistance: should be equal to Z_{OUT} of the Pulse Generator.

Switching Waveforms

Propagation Delay

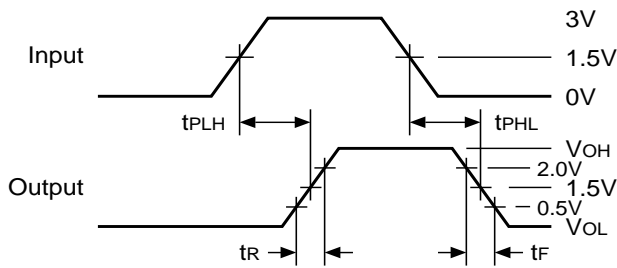

Pulse Skew – $t_{sk(p)}$

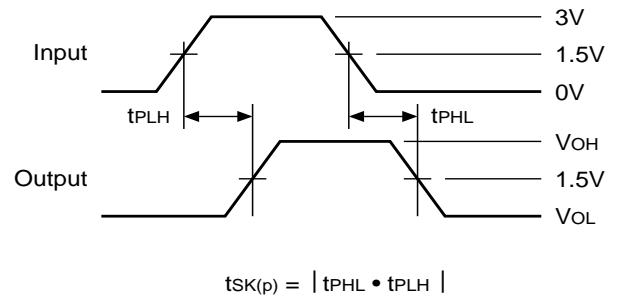

Output Skew – $t_{sk(o)}$

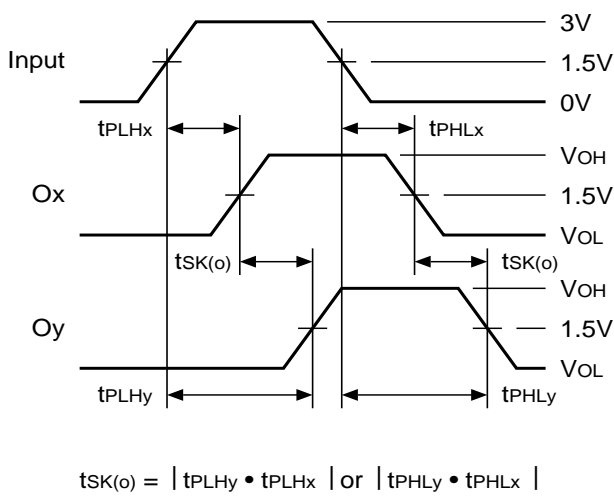

Package Skew – $t_{sk(t)}$

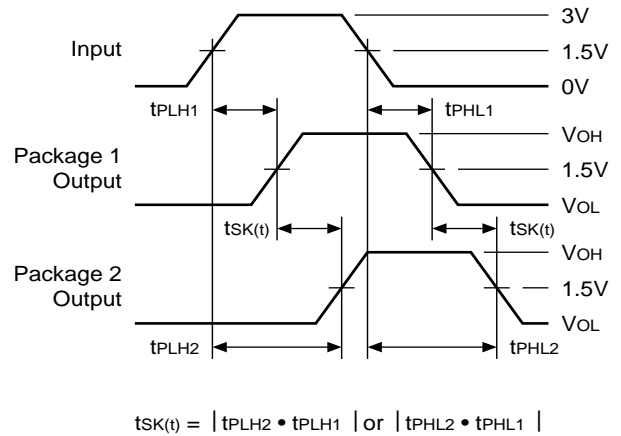

Packaging Mechanical: 20-Pin 209-Mil SSOP (H)

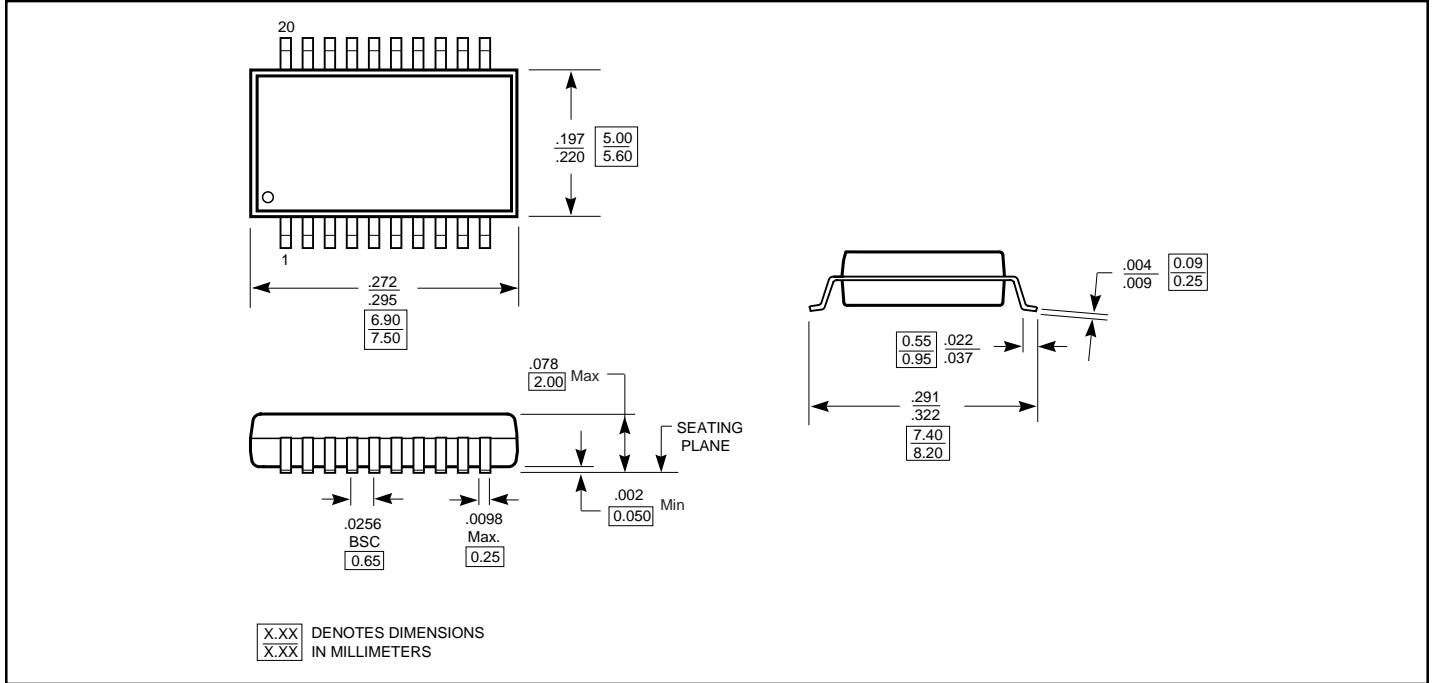

Packaging Mechanical: 20-Pin 150-Mil QSOP (Q)

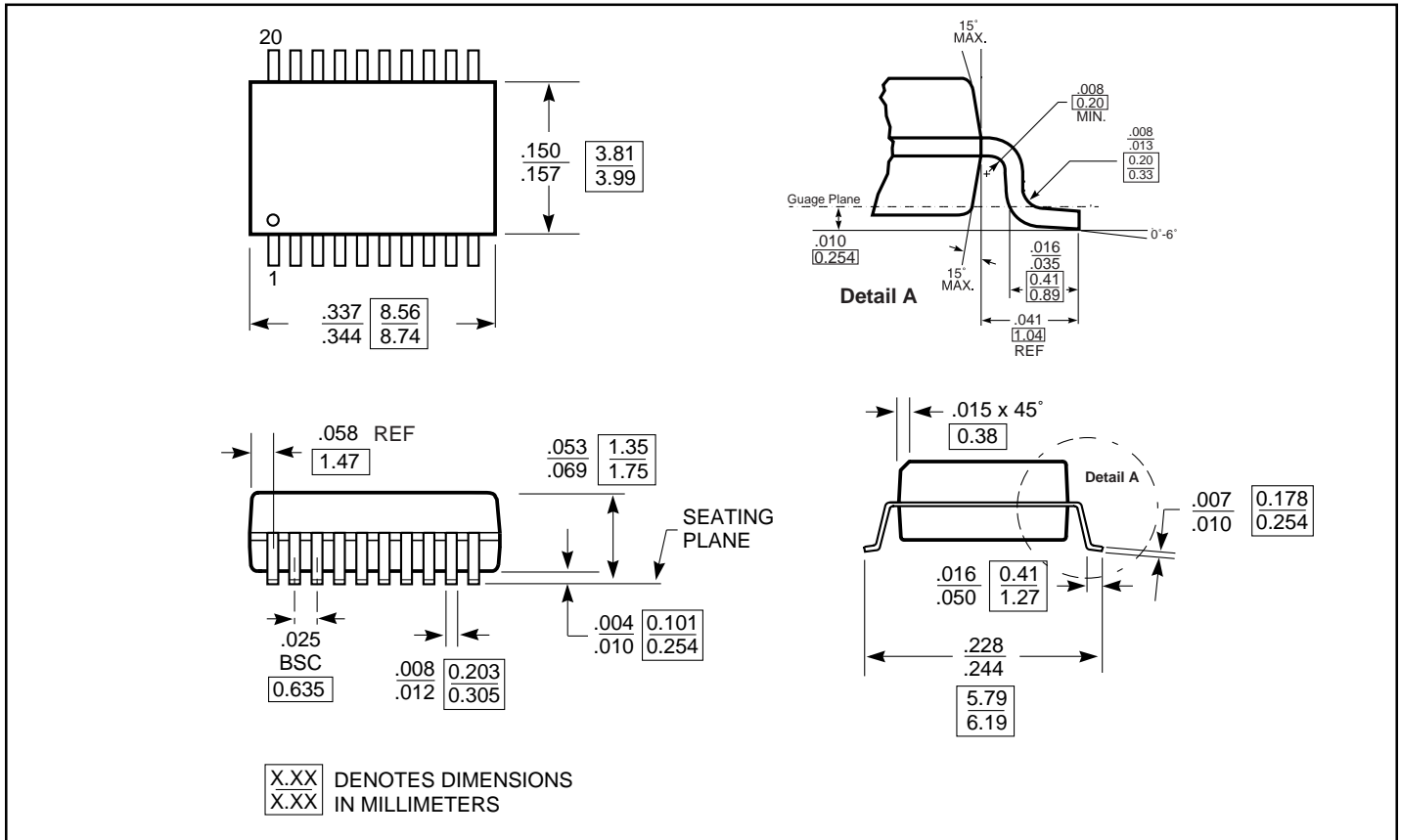

Packaging Mechanical: 20-Pin 300-Mil SOIC (S)

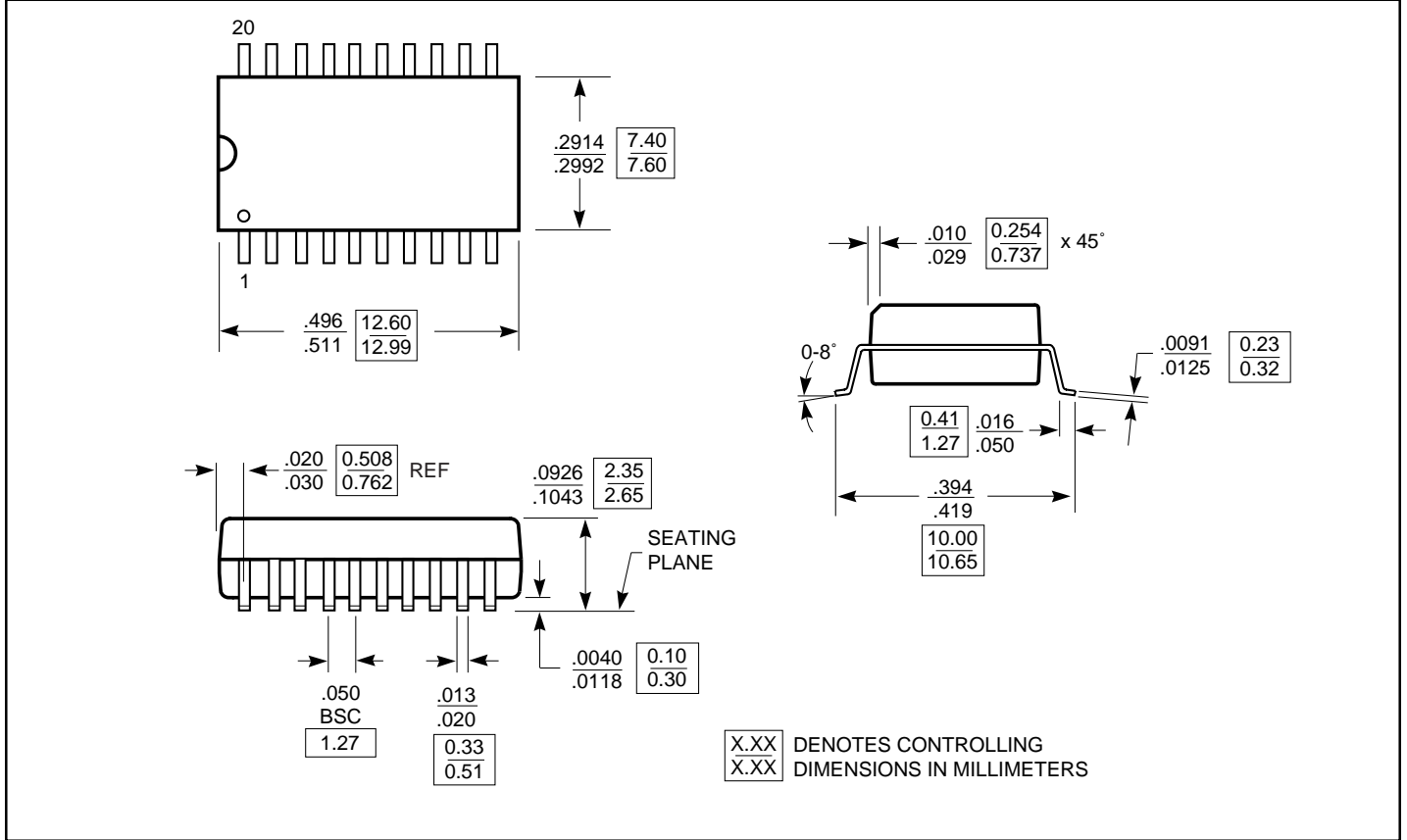

Ordering Information



Ordering Code	Package Code	Speed Grade	Package Type
PI49FCT807TS	S	Blank	20-pin 300-mil SOIC
PI49FCT807TSE	S	Blank	Pb-free & Green, 20-pin 300-mil SOIC
PI49FCT807TQ	Q	Blank	20-pin 150-mil QSOP
PI49FCT807TQE	Q	Blank	Pb-free & Green, 20-pin 150-mil QSOP
PI49FCT807TH	H	Blank	20-pin 209-mil SSOP
PI49FCT807THE	H	Blank	Pb-free & Green, 20-pin 209-mil SSOP
PI49FCT807ATS	S	A	20-pin 300-mil SOIC
PI49FCT807ATSE	S	A	Pb-free & Green, 20-pin 300-mil SOIC
PI49FCT807ATQ	Q	A	20-pin 150-mil QSOP
PI49FCT807ATQE	Q	A	Pb-free & Green, 20-pin 150-mil QSOP
PI49FCT807ATH	H	A	20-pin 209-mil SSOP
PI49FCT807ATHE	H	A	Pb-free & Green, 20-pin 209-mil SSOP
PI49FCT807BTS	S	B	20-pin 300-mil SOIC
PI49FCT807BTSE	S	B	Pb-free & Green, 20-pin 300-mil SOIC
PI49FCT807BTQ	Q	B	20-pin 150-mil QSOP
PI49FCT807BTQE	Q	B	Pb-free & Green, 20-pin 150-mil QSOP
PI49FCT807BTH	H	B	20-pin 209-mil SSOP
PI49FCT807BTHE	H	B	Pb-free & Green, 20-pin 209-mil SSOP
PI49FCT807CTS	S	C	20-pin 300-mil SOIC
PI49FCT807CTSE	S	C	Pb-free & Green, 20-pin 300-mil SOIC
PI49FCT807CTQ	Q	C	20-pin 150-mil QSOP
PI49FCT807CTQE	Q	C	Pb-free & Green, 20-pin 150-mil QSOP
PI49FCT807CTH	H	C	20-pin 209-mil SSOP
PI49FCT807CTHE	H	C	Pb-free & Green, 20-pin 209-mil SSOP
PI49FCT2807TS	S	Blank	20-pin 300-mil SOIC
PI49FCT2807TSE	S	Blank	Pb-free & Green, 20-pin 300-mil SOIC
PI49FCT2807TQ	Q	Blank	20-pin 150-mil QSOP
PI49FCT2807TQE	Q	Blank	Pb-free & Green, 20-pin 150-mil QSOP
PI49FCT2807TH	H	Blank	20-pin 209-mil SSOP
PI49FCT2807THE	H	Blank	Pb-free & Green, 20-pin 209-mil SSOP

Notes:

1. Thermal characteristics can be found on the company web site at www.pericom.com/packaging/

Looking for pricing, stock, or lifecycle information?

Click below to explore more details on WIN SOURCE:

-  [View PI49FCT807BTSE on WIN SOURCE](#)
-  [Diodes Incorporated Information](#)

Optimize Your Supply Chain with WIN SOURCE Solutions

-  Global Sourcing Solution
-  Obsolete Management
-  Cost Control Management
-  Shortage Management
-  Alternative Solution
-  Excess Inventory Management