



Q-SMINT[®]
2B1Q Second Gen. Modular ISDN NT
(Intelligent)
PEF 82912/82913 Version 1.3

Wired
Communications



Never stop thinking.

Edition March 2001

**Published by Infineon Technologies AG,
St.-Martin-Strasse 53,
D-81541 München, Germany**

**© Infineon Technologies AG 2001.
All Rights Reserved.**

Attention please!

The information herein is given to describe certain components and shall not be considered as warranted characteristics.

Terms of delivery and rights to technical change reserved.

We hereby disclaim any and all warranties, including but not limited to warranties of non-infringement, regarding circuits, descriptions and charts stated herein.

Infineon Technologies is an approved CECC manufacturer.

Information

For further information on technology, delivery terms and conditions and prices please contact your nearest Infineon Technologies Office in Germany or our Infineon Technologies Representatives worldwide (see address list).

Warnings

Due to technical requirements components may contain dangerous substances. For information on the types in question please contact your nearest Infineon Technologies Office.

Infineon Technologies Components may only be used in life-support devices or systems with the express written approval of Infineon Technologies, if a failure of such components can reasonably be expected to cause the failure of that life-support device or system, or to affect the safety or effectiveness of that device or system. Life support devices or systems are intended to be implanted in the human body, or to support and/or maintain and sustain and/or protect human life. If they fail, it is reasonable to assume that the health of the user or other persons may be endangered.

Q-SMINT[®]I

2B1Q **Second Gen. Modular ISDN NT**

(Intelligent)

PEF 82912/82913 Version 1.3

Wired
Communications



Never stop thinking.

Previous Version: Preliminary Data Sheet 10.00

Page	Subjects (major changes since last revision)
All	Editorial changes, addition of notes for clarification etc.
Table 1, Chapter 1.3	Introduced new version 82913 with extended performance of the U-interface
Chapter 2.1.1.1	SCI: header description: added to sequences 43 _H , 41 _H and 49 _H : 'Generally, it can be used for any register access to the address range 20 _H -7D _H .'
Chapter 2.3.2	IOM-2 handler: removed 'U-transceiver (U)' from listing of functional units with programmable time slot and data port.
Figure 12	Figure 'Data Access via CDAX0 and CDAX1 register pairs' corrected: input swap has influence on the input enable (EN_I0,1), too
Chapter 2.5.5.2	C/I commands: removed 'unconditional command' from description C/I-command 'DR'
Chapter 2.5.5.3	LT-S state machine: C/I=command AIL removed (no valid input to the LT-S state machine)
Chapter 4	Detailed register description: <ul style="list-style-type: none"> • U-transceiver Mode Evaluation Timing: clarified description • register ID: reset value of version 1.3 is 01_H (not 00_H) • CIX1.CODX1: bits 5-0 of C/I-channel 1 (not 7-2) • IOM_CR:TIC_DIS: added for clarification: 'This means that the timeslots TIC, A/ B, S/G and BAC are not available any more.'
Chapter 5.1	Refined references for ESD requirements: '...(CDM), EIA/JESD22-A114B (HBM) ----'
Chapter 5.2	Input/output leakage current set to 10µA (before: 1µA)
Table 38	U-transceiver characteristics: enhanced S/N+D for 82913 and threshold level for 82912 and 82913 distinguished
Chapter 5.1	Absolute Maximum Ratings: Maximum Voltage on VDD: 4.2V (before: 4.6V)
Chapter 5.6.2 Chapter 5.6.3	AC-Timing SCI/parallel µC interface: enhanced timing specifications
Chapter 5.6.3	Added restriction for control interval t _{RI}
Chapter 5.6.5	Parameters of the UVD/POR Circuit: defined reduced range of hysteresis: min. 30mV/max. 90mV relaxed upper limit of Detection Threshold to 2.92V (before: 2.9V) defined max. rising VDD for power-on
Chapter 7.2.5	Register summary U-transceiver 4B3T: Reset value of MASKU is FF _H (not 00 _H)
Chapter 7.3	External circuitry for T-SMINT updated

For questions on technology, delivery and prices please contact the Infineon Technologies Offices in Germany or the Infineon Technologies Companies and Representatives worldwide: see our webpage at <http://www.infineon.com>

Table of Contents		Page
1	Overview	1
1.1	References	2
1.2	Features PEF 82912	3
1.3	Features PEF 82913	4
1.4	Not Supported are	5
1.5	Pin Configuration	6
1.6	Block Diagram	7
1.7	Pin Definitions and Functions	8
1.7.1	Specific Pins	13
1.8	System Integration	14
2	Functional Description	17
2.1	Microcontroller Interfaces	17
2.1.1	Serial Control Interface (SCI)	18
2.1.1.1	Programming Sequences	20
2.1.2	Parallel Microcontroller Interface	22
2.1.3	Microcontroller Clock Generation	24
2.2	Reset Generation	25
2.3	IOM [®] -2 Interface	28
2.3.1	IOM,-2 Functional Description	28
2.3.2	IOM,-2 Handler	29
2.3.2.1	Controller Data Access (CDA)	31
2.3.2.2	Serial Data Strobe Signal	41
2.3.3	IOM,-2 Monitor Channel	42
2.3.3.1	Handshake Procedure	42
2.3.3.2	Error Treatment	46
2.3.3.3	MONITOR Channel Programming as a Master Device	48
2.3.3.4	MONITOR Channel Programming as a Slave Device	48
2.3.3.5	Monitor Time-Out Procedure	49
2.3.3.6	MONITOR Interrupt Logic	49
2.3.4	C/I Channel Handling	50
2.3.5	D-Channel Access Control	52
2.3.5.1	Application Examples for D-Channel Access Control	52
2.3.5.2	TIC Bus Handling	53
2.3.5.3	Stop/Go Bit Handling	54
2.3.5.4	D-Channel Arbitration	55
2.3.5.5	State Machine of the D-Channel Arbiter	56
2.3.6	Activation/Deactivation of IOM [®] -2 Interface	59
2.4	U-Transceiver	60
2.4.1	2B1Q Frame Structure	60
2.4.2	Maintenance Channel	64
2.4.2.1	Reporting to the μ C Interface	64
2.4.2.2	Access from the μ C Interface	64

Table of Contents		Page
2.4.2.3	Availability of Maintenance Channel Information	64
2.4.2.4	M-Bit Register Access Timing	65
2.4.3	Processing of the EOC	67
2.4.3.1	EOC Commands	67
2.4.3.2	EOC Processor	69
2.4.3.3	EOC Operating Modes	71
2.4.3.4	Examples for different EOC modes	72
2.4.4	Processing of the Overhead Bits M4, M5, M6	75
2.4.4.1	M4 Bit Reporting to the μ C	75
2.4.4.2	M4 Bit Reporting to State Machine	75
2.4.4.3	M5, M6 Bit Reporting to the μ C	75
2.4.4.4	Summary of M4, M5, M6 Bit Reporting	75
2.4.5	M4, M5, M6 Bit Control Mechanisms	77
2.4.6	Cyclic Redundancy Check / FEBE bit	79
2.4.7	Block Error Counters	81
2.4.7.1	Near-End and Far-End Block Error Counter	81
2.4.7.2	Testing Block Error Counters	81
2.4.8	Scrambling/ Descrambling	83
2.4.9	C/I Codes	83
2.4.10	State Machines for Line Activation / Deactivation	85
2.4.10.1	Notation	85
2.4.10.2	Standard NT State Machine (IEC-Q / NTC-Q Compatible)	87
2.4.10.3	Inputs to the U-Transceiver:	88
2.4.10.4	Outputs of the U-Transceiver:	89
2.4.10.5	Description of the NT-States	93
2.4.10.6	Simplified NT State Machine	95
2.4.11	Metallic Loop Termination	99
2.4.12	U-Transceiver Interrupt Structure	101
2.5	S-Transceiver	103
2.5.1	Line Coding, Frame Structure	103
2.5.2	S/Q Channels, Multiframeing	105
2.5.3	Data Transfer between IOM,-2 and S0	106
2.5.4	Loopback 2	106
2.5.5	Control of S-Transceiver / State Machine	106
2.5.5.1	C/I Codes	109
2.5.5.2	State Machine NT Mode	111
2.5.5.3	State Machine LT-S Mode	115
2.5.6	S-Transceiver Enable / Disable	118
2.5.7	Interrupt Structure S-Transceiver	119
3	Operational Description	120
3.1	Layer 1 Activation/Deactivation	120
3.1.1	Complete Activation Initiated by Exchange	120

Table of Contents		Page
3.1.2	Complete Activation Initiated by TE	121
3.1.3	Complete Activation Initiated by NT	122
3.1.4	Complete Deactivation	123
3.1.5	Loop 2	124
3.2	Layer 1 Loopbacks	125
3.2.1	Analog Loopback U-Transceiver (No. 3)	125
3.2.2	Analog Loop-Back S-Transceiver	126
3.2.3	Loopback No.2	127
3.2.3.1	Complete Loopback	127
3.2.3.2	Loopback No.2 - Single Channel Loopbacks	128
3.2.4	Local Loopbacks Featured By the LOOP Register	128
3.3	External Circuitry	130
3.3.1	Power Supply Blocking Recommendation	130
3.3.2	U-Transceiver	130
3.3.3	S-Transceiver	132
3.3.4	Oscillator Circuitry	134
3.3.5	General	135
4	Register Description	136
4.1	Address Space	136
4.2	Interrupts	137
4.3	Register Summary	139
4.4	Reset of U-Transceiver Functions During Deactivation or with C/I-Code RESET 146	
4.5	U-Transceiver Mode Register Evaluation Timing	147
4.6	Detailed C/I Registers	148
4.6.1	MODEH - Mode Register IOM-2	148
4.6.2	CIR0 - Command/Indication Receive 0	148
4.6.3	CIX0 - Command/Indication Transmit 0	150
4.6.4	CIR1 - Command/Indication Receive 1	151
4.6.5	CIX1 - Command/Indication Transmit 1	151
4.7	Detailed S-Transceiver Registers	152
4.7.1	S_CONF0 - S-Transceiver Configuration Register 0	152
4.7.2	S_CONF2 - S-Transmitter Configuration Register 2	153
4.7.3	S_STA - S-Transceiver Status Register	154
4.7.4	S_CMD - S-Transceiver Command Register	155
4.7.5	SQRR - S/Q-Channel Receive Register	156
4.7.6	SQXR- S/Q-Channel Transmit Register	156
4.7.7	ISTAS - Interrupt Status Register S-Transceiver	157
4.7.8	MASKS - Mask S-Transceiver Interrupt	158
4.7.9	S_MODE - S-Transceiver Mode	159
4.8	Interrupt and General Configuration Registers	160
4.8.1	ISTA - Interrupt Status Register	160

Table of Contents		Page
4.8.2	MASK - Mask Register	161
4.8.3	MODE1 - Mode1 Register	162
4.8.4	MODE2 - Mode2 Register	163
4.8.5	ID - Identification Register	164
4.8.6	SRES - Software Reset Register	165
4.9	Detailed IOM [®] -2 Handler Registers	165
4.9.1	CDAXy - Controller Data Access Register xy	165
4.9.2	XXX_TSDPxy - Time Slot and Data Port Selection for CHxy	166
4.9.3	CDAX_CR - Control Register Controller Data Access CH1x	167
4.9.4	S_CR - Control Register S-Transceiver Data	168
4.9.5	CI_CR - Control Register for CI1 Data	169
4.9.6	MON_CR - Control Register Monitor Data	170
4.9.7	SDS1_CR - Control Register Serial Data Strobe 1	171
4.9.8	SDS2_CR - Control Register Serial Data Strobe 2	172
4.9.9	IOM_CR - Control Register IOM Data	173
4.9.10	MCDA - Monitoring CDA Bits	174
4.9.11	STI - Synchronous Transfer Interrupt	174
4.9.12	ASTI - Acknowledge Synchronous Transfer Interrupt	175
4.9.13	MSTI - Mask Synchronous Transfer Interrupt	175
4.10	Detailed MONITOR Handler Registers	176
4.10.1	MOR - MONITOR Receive Channel	176
4.10.2	MOX - MONITOR Transmit Channel	176
4.10.3	MOSR - MONITOR Interrupt Status Register	177
4.10.4	MOCR - MONITOR Control Register	177
4.10.5	MSTA - MONITOR Status Register	178
4.10.6	MCONF - MONITOR Configuration Register	179
4.11	Detailed U-Transceiver Registers	179
4.11.1	OPMODE - Operation Mode Register	179
4.11.2	MFILT - M Bit Filter Options	180
4.11.3	EOCR - EOC Read Register	181
4.11.4	EOCW - EOC Write Register	182
4.11.5	M4RMASK - M4 Read Mask Register	183
4.11.6	M4WMASK - M4 Write Mask Register	183
4.11.7	M4R - M4 Read	184
4.11.8	M4W - M4 Write Register	185
4.11.9	M56R - M56 Read Register	186
4.11.10	M56W - M56 Write Register	187
4.11.11	UCIR - C/I Code Read Register	187
4.11.12	UCIW - C/I Code Write Register	188
4.11.13	TEST - Test Register	188
4.11.14	LOOP - Loop Back Register	189
4.11.15	FEBE - Far End Block Error Counter Register	190

Table of Contents		Page
4.11.16	NEBE - Near End Block Error Counter Register	191
4.11.17	ISTAU - Interrupt Status Register U-Interface	191
4.11.18	MASKU - Mask Register U-Interface	192
4.11.19	FW_VERSION	193
5	Electrical Characteristics	194
5.1	Absolute Maximum Ratings	194
5.2	DC Characteristics	195
5.3	Capacitances	197
5.4	Power Consumption	197
5.5	Supply Voltages	197
5.6	AC Characteristics	199
5.6.1	IOM [®] -2 Interface	200
5.6.2	Serial μ P Interface	202
5.6.3	Parallel μ P Interface	203
5.6.4	Reset	206
5.6.5	Undervoltage Detection Characteristics	207
6	Package Outlines	209
7	Appendix: Differences between Q- and T-SMINT,I	211
7.1	Pinning	211
7.2	U-Transceiver	212
7.2.1	U-Interface Conformity	212
7.2.2	U-Transceiver State Machines	213
7.2.3	Command/Indication Codes	216
7.2.4	Interrupt Structure	217
7.2.5	Register Summary U-Transceiver	219
7.3	External Circuitry	222
8	Index	224

List of Figures		Page
Figure 1	Pin Configuration	6
Figure 2	Block Diagram	7
Figure 3	Application Example Q-SMINT [®] I: High Feature Intelligent NT	14
Figure 4	Control via μ P Interface	15
Figure 5	Control via IOM [®] -2 Interface	16
Figure 6	Serial Control Interface Timing	19
Figure 7	Serial Command Structure.	20
Figure 8	Direct/Indirect Register Address Mode	24
Figure 9	Reset Generation of the Q-SMINT [®] I	25
Figure 10	IOM [®] -2 Frame Structure of the Q-SMINT,I	28
Figure 11	Architecture of the IOM [®] -2 Handler	30
Figure 12	Data Access via CDAX0 and CDAX1 register pairs	32
Figure 13	Examples for Data Access via CDAXy Registers.	33
Figure 14	Data Access when Looping TSa from DU to DD	34
Figure 15	Data Access when Shifting TSa to TSb on DU (DD).	35
Figure 16	Example for Monitoring Data	36
Figure 17	Interrupt Structure of the Synchronous Data Transfer.	39
Figure 18	Examples for the Synchronous Transfer Interrupt Control with one STlxy enabled.	40
Figure 19	Data Strobe Signal Generation	41
Figure 20	MONITOR Channel Protocol (IOM [®] -2)	44
Figure 21	Monitor Channel, Transmission Abort requested by the Receiver.	47
Figure 22	Monitor Channel, Transmission Abort requested by the Transmitter.	47
Figure 23	Monitor Channel, Normal End of Transmission	47
Figure 24	MONITOR Interrupt Structure	50
Figure 25	CIC Interrupt Structure.	51
Figure 26	D-Channel Arbitration: μ C with HDLC and Direct Access to TIC Bus	52
Figure 27	D-Channel Arbitration: μ C with HDLC and no Access to TIC Bus.	53
Figure 28	Structure of Last Octet of Ch2 on DU	54
Figure 29	Structure of Last Octet of Ch2 on DD	55
Figure 30	State Machine of the D-Channel Arbiter (Simplified View).	57
Figure 31	Deactivation of the IOM [®] -2 Clocks	59
Figure 32	U-Superframe Structure.	60
Figure 33	U-Basic Frame Structure	61
Figure 34	U2B1Q Framer - Data Flow Scheme.	63
Figure 35	U2B1Q Deframer - Data Flow Scheme	63
Figure 36	Write Access Timing	66
Figure 37	Read Access Timing	67
Figure 38	EOC Message Reception	70
Figure 39	EOC Command/Message Transmission	70
Figure 40	Maintenance Channel Filtering Options.	76
Figure 41	M4 Bit Report Timing (Statemachine vs. μ C).	76

List of Figures	Page
Figure 42	M4, M5, M6 Bit Control in Receive Direction 78
Figure 43	M4, M5, M6 Bit Control in Transmit Direction 78
Figure 44	CRC-Process 80
Figure 45	Block Error Counter Test 83
Figure 46	Explanation of State Diagram Notation 86
Figure 47	Standard NT State Machine (IEC-Q / NTC-Q Compatible) (Footnotes: see “Dependence of Outputs” on Page 92) 87
Figure 48	Simplified NT State Machine 98
Figure 49	Pulse Streams Selecting Quiet Mode 100
Figure 50	Interrupt Structure U-Transceiver 102
Figure 51	S/T -Interface Line Code 103
Figure 52	Frame Structure at Reference Points S and T (ITU I.430). 104
Figure 53	S-Transceiver Control 107
Figure 54	State Diagram Notation 108
Figure 55	State Machine NT Mode 111
Figure 56	State Machine LT-S Mode 115
Figure 57	Interrupt Structure S-Transceiver. 119
Figure 58	Complete Activation Initiated by Exchange 120
Figure 59	Complete Activation Initiated by TE 121
Figure 60	Complete Activation Initiated by Q-SMINT [®] I 122
Figure 61	Complete Deactivation Initiated by Exchange 123
Figure 62	Loop 2 124
Figure 63	Test Loopbacks 125
Figure 64	External Loop at the S/T-Interface 126
Figure 65	Complete Loopback Options in NT-Mode 127
Figure 66	Loopbacks Featured by Register LOOP 129
Figure 67	Power Supply Blocking 130
Figure 68	External Circuitry U-Transceiver 131
Figure 69	External Circuitry S-Interface Transmitter 133
Figure 70	External Circuitry S-Interface Receiver 134
Figure 71	Crystal Oscillator 134
Figure 72	Address Space. 136
Figure 73	Q-SMINT [®] I Interrupt Status Registers. 137
Figure 74	Maximum Sinusoidal Ripple on Supply Voltage 198
Figure 75	Input/Output Waveform for AC Tests. 199
Figure 76	IOM [®] -2 Interface - Bit Synchronization Timing 200
Figure 77	IOM [®] -2 Interface - Frame Synchronization Timing 200
Figure 78	Serial Control Interface 202
Figure 79	Microprocessor Read Cycle. 203
Figure 80	Microprocessor Write Cycle 203
Figure 81	Multiplexed Address Timing. 203
Figure 82	Non-Multiplexed Address Timing 204

List of Figures	Page
Figure 83	Microprocessor Read Timing 204
Figure 84	Microprocessor Write Cycle 204
Figure 85	Non-Multiplexed Address Timing 205
Figure 86	Reset Input Signal 206
Figure 87	Undervoltage Control Timing 207
Figure 88	INTC-Q Compatible State Machine Q-SMINT [®] : 2B1Q 213
Figure 89	Simplified State Machine Q-SMINT [®] : 2B1Q 214
Figure 90	IEC-T/NTC-T Compatible State Machine T-SMINT,I: 4B3T 215
Figure 91	Interrupt Structure U-Transceiver Q-SMINT [®] : 2B1Q 217
Figure 92	Interrupt Structure U-Transceiver T-SMINT,I: 4B3T 218
Figure 93	External Circuitry Q- and T-SMINT,I 222

List of Tables		Page
Table 1	NT Products of the 2nd Generation	1
Table 2	Pin Definitions and Functions	8
Table 3	ACT States	13
Table 4	Interface Selection for the Q-SMINT,I	17
Table 5	Header Byte Code	20
Table 6	Bus Operation Modes	22
Table 7	MCLK Frequencies	24
Table 8	Reset Source Selection	26
Table 9	Examples for Synchronous Transfer Interrupts	38
Table 10	Transmit Direction	43
Table 11	Receive Direction	43
Table 12	Q-SMINT [®] I Configuration Settings in Intelligent NT Applications	56
Table 13	Major Differences D-Channel Arbiter INTC-Q and Q-SMINT [®] I	57
Table 14	U-Superframe Format	61
Table 15	Enabling the Maintenance Channel (Receive Direction)	64
Table 16	Coding of EOC-Commands	68
Table 17	Usage of Supported EOC-Commands	68
Table 18	EOC Auto Mode	73
Table 19	Transparent mode 6 ms	74
Table 20	Transparent mode '@change'	74
Table 21	Transparent mode TLL	74
Table 22	U - Transceiver C/I Codes	84
Table 23	Timers Used	89
Table 24	U-Interface Signals	90
Table 25	Signal Output on Uk0	92
Table 26	C/I-Code Output	92
Table 27	Changes to achieve Simplified NT State Machine	96
Table 28	Appearance of the State Machine to the Software	99
Table 29	ANSI Maintenance Controller States	100
Table 30	S/Q-Bit Position Identification and Multi-Frame Structure	105
Table 31	U-Transformer Parameters	131
Table 32	S-Transformer Parameters	132
Table 33	Crystal Parameters	135
Table 34	Reset of U-Transceiver Functions During Deactivation or with C/I-Code RESET	146
Table 36	Maximum Input Currents	194
Table 37	S-Transceiver Characteristics	195
Table 38	U-Transceiver Characteristics	196
Table 39	Pin Capacitances	197
Table 40	Reset Input Signal Characteristics	206
Table 41	Parameters of the UVD/POR Circuit	207
Table 42	Pin Definitions and Functions	211

List of Tables**Page**

Table 43	Related Documents to the U-Interface.	212
Table 44	C/I Codes.	216
Table 45	Dimensions of External Components.	223

1 Overview

The **PEF 82912 / 82913** (Q-SMINT[®]I) offers U-transceiver, S-transceiver and an IOM[®]-2 interface. A microcontroller interface provides access to both transceivers as well as the IOM[®]-2 interface.

However, as opposed to its bigger brother Q-SMINT[®]IX, the Q-SMINT[®]I does not have an HDLC controller. Main target applications of the Q-SMINT[®]I are intelligent NT applications where the HDLC controller(s) is (are) provided by the microcontroller or other additional components. An example for such a microcontroller is the Infineon UTAH chip which features four flexible HDLC controllers.

Table 1 summarizes the 2nd generation NT products.

Table 1 NT Products of the 2nd Generation

	PEF80912	PEF80913	PEF81912	PEF81913	PEF82912	PEF82913
	Q-SMINT [®] O		Q-SMINT [®] IX		Q-SMINT [®] I	
Package	P-MQFP-44		P-MQFP-64 P-TQFP-64		P-MQFP-64 P-TQFP-64	
Register access	no		U+S+HDLC+ IOM [®] -2		U+S+ IOM [®] -2	
Access via	n.a.		parallel (or SCI or IOM [®] -2)		parallel (or SCI or IOM [®] -2)	
MCLK, watchdog timer, SDS, BCL, D-channel arbitration, IOM [®] -2 access and manipulation etc. provided	no		yes		yes	
HDLC controller	no		yes		no	
NT1 mode available	yes (only)		no		no	
Extended U-Performance 20kft	no	yes	no	yes	no	yes

1.1 References

- [1] TS 102 080, Transmission and Multiplexing ; ISDN basic rate access; Digital transmission system on metallic local lines, ETSI, November 1998
- [2] T1.601-1998 (Revision of ANSI T1.601-1992), ISDN-Basic Access Interface for Use on Metallic Loops for Application on the Network Side of the NT (Layer 1 Specification), ANSI, 1998
- [3] ST/LAA/ELR/DNP/822, CNET, France
- [4] RC7355E, 2B1Q Generic Physical Layer Specification, British Telecommunications plc., 1997
- [5] FZA TS 0095/01:1997-10, Technische Spezifikationen für Netzabschlußgeräte für den ISDN Basisanschluß (NT-BA), Post & Telekom Austria, 1997
- [6] pr ETS 300 012 Draft, ISDN; Basic User Network Interface (UNI), ETSI, November 1996
- [7] T1.605-1991, ISDN-Basic Access Interface for S and T Reference Points (Layer 1 Specification), ANSI, 1991
- [8] I.430, ISDN User-Network Interfaces: Layer 1 Recommendations, ITU, November 1988
- [9] IEC-Q, ISDN Echocancellation Circuit, PEB 2091 V4.3, User's Manual 02.95, Siemens AG, 1995
- [10] SBCX, S/T Bus Interface Circuit Extended, PEB 2081 V3.4, User's Manual 11.96, Siemens AG, 1996
- [11] NTC-Q, Network Termination Controller (2B1Q), PEB / PEF 8091 V1.1, Data Sheet 10.97, Siemens AG, 1997
- [12] INTC-Q, Intelligent Network Termination Controller (2B1Q), PEB / PEF 8191 V1.1, Data Sheet 10.97, Siemens AG, 1997
- [13] IOM[®]-2 Interface Reference Guide, Siemens AG, 03.91
- [14] SCOUT-S(X), Siemens Codec with S/T-Transceiver, PSB 2138x V1.3, Preliminary Data Sheet 8.99, Infineon Technologies, 1999
- [15] PITA, PCI Interface for Telephony/Data Applications V0.3, SICAN GmbH, September 1997
- [16] Dual Channel SLICOFI-2, HV-SLIC; DUSLIC; PEB3265, 4265, 4266; Data Sheet DS2, Infineon Technologies, July 2000.

**2B1Q Second Gen. Modular ISDN NT (Intelligent)
Q-SMINT[®]I**

PEF 82912/82913

Version 1.3

1.2 Features PEF 82912

Features known from the PEB/PEF 8191

- U-transceiver and S-transceiver on one chip
- Perfectly suited for high-end intelligent NTs that require multiple HDLC controllers (which are provided externally)
- U-interface (2B1Q) conform to ETSI [1], ANSI [2] and CNET [3]:
 - Meets all transmission requirements on all ETSI, ANSI and CNET loops with margin
 - Conform to British Telecom’s RC7355E [4]
 - Compliant with ETSI 10 ms micro interruptions
 - MLT input and decode logic (ANSI [2])
- S/T-interface conform to ETSI [6], ANSI [7] and ITU [8]
 - Supports point-to-point and bus configurations
 - Meets and exceeds all transmission requirements
- Activation status LED supported
- BCL, SDS1, SDS2, programmable MCLK, watchdog timer,
- Access to IOM[®]-2 C/I and Monitor channels
- Power-down and reset states (e.g. S-transceiver) for individual circuits
- Automatic D-channel arbitration between S-bus and external HDLC controller
- Parallel or serial μ P-interface

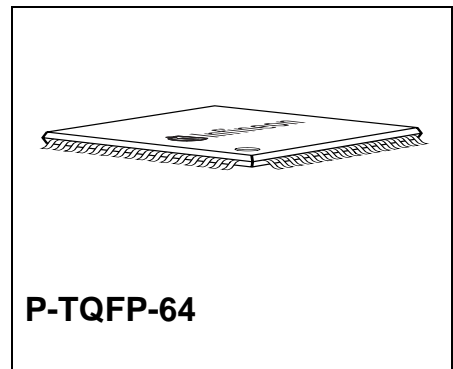
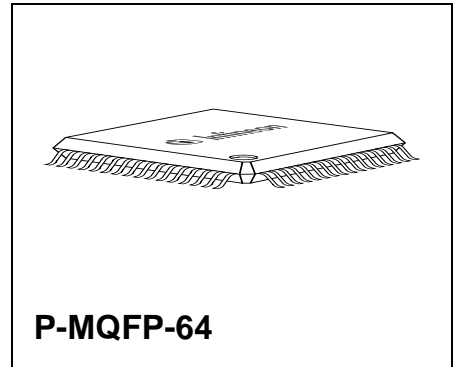

Type	Package
PEF 82912/82913	P-MQFP-64
PEF 82912/82913	P-TQFP-64

New Features

- Reduced number of external components for external U-hybrid required
- Optional use of up to $2 \times 20 \Omega$ resistors on the line side of the transformer (e.g. PTCs)
- Pin Uref and the according external capacitor removed
- Improved ESD (2 kV instead of <850 V)
- Inputs accept 3.3 V and 5 V
- I/O (open drain) accepts pull-up to 3.3 V¹⁾
- LED signal is programmable but can also automatically indicate the activation status (mode select via 1 bit)
- Pin compatible with T-SMINT[®]I (2nd Generation)
- Priority setting (8/10) for off-chip HDLC controller
- Enhanced IOM[®]-2 timeslot access and manipulation (SCOUT)
- MCLK can be disabled (SCOUT)
- External Awake ($\overline{\text{EAW}}$)
- Optional: All registers can be read and written to via new Monitor channel concept
- Optional: Implementation of S-transceiver statemachine in software
- Indirect Addressing (SCOUT)
- Programmable strobes SDS1/2 are more flexible, e.g. active during several timeslots
- Power-on reset and Undervoltage Detection with no external components
- Lowest power consumption due to:
 - Low power CMOS technology (0.35 μ)
 - Newly optimized low-power libraries
 - High output swing on U- and S-line interface leads to minimized power consumption
 - Single 3.3 Volt power supply
- 200 mW (INTC-Q: 295 mW) power consumption with random data over ETSI Loop 2 (external loads on the S and U interface only and no additional external loads).
- 15 mW typical power consumption in power down (INTC-Q: 28 mW)

1.3 Features PEF 82913

The Q-SMINT[®]I PEF 82913 provides all features of the PEF 82912. Additionally, a significantly enhanced performance of the U-interface as compared to ETSI [1], ANSI [2] and CNET [3] requirements is guaranteed:

Transparent transmission on 20kft AWG26 with a BER < 10^{-7} (without noise).

¹⁾ Pull-ups to 5 V must be avoided. A so-called 'hot-electron-effect' would lead to long term degradation.

1.4 Not Supported are ...

- Integrated U-hybrid
- On-chip HDLC controller
- 'Self test request' and 'Self test passed' of U-transceiver
- TE-mode of the S-transceiver
- DECT-link capability
- SRA (capacitive receiver coupling is not suited for S-feeding).
- 'NT-Star' with star point on the IOM[®]-2 bus (already not supported in INTC-Q).
- No access to S2-5 channels. Access only to S1 and Q channel as in SCOUT. No selection between transparent and non-auto mode provided.
- The oscillator architecture was changed with respect to the INTC-Q to reduce power consumption. As a consequence, the Q-SMINT[®]I always needs a crystal and pin XIN can not be connected to an external clock as it was possible for IEC-Q and NTC-Q. This does not limit the use of the Q-SMINT[®]I in NTs since all NT designs use crystals anyway.

1.5 Pin Configuration

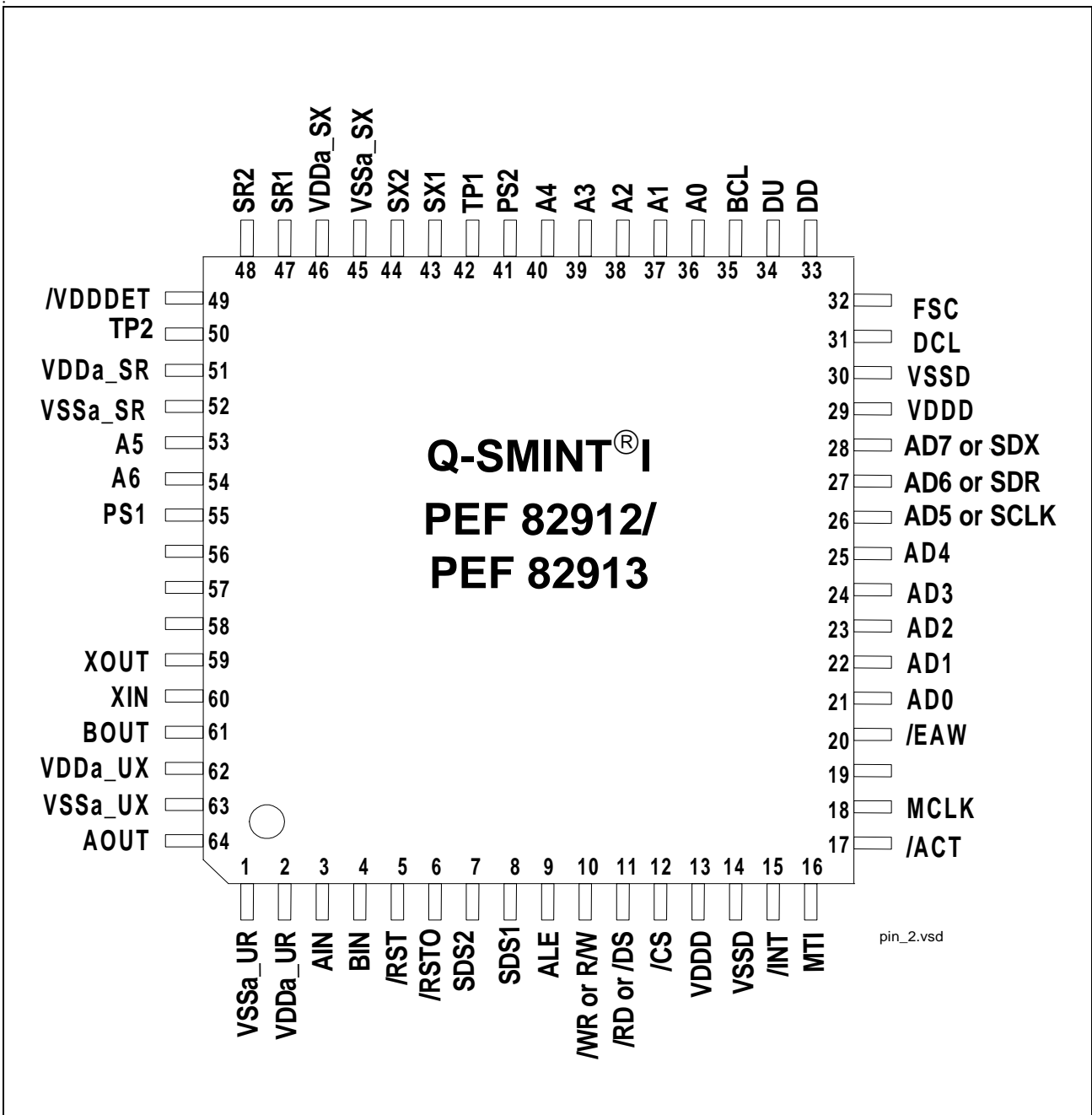

Figure 1 Pin Configuration

1.6 Block Diagram

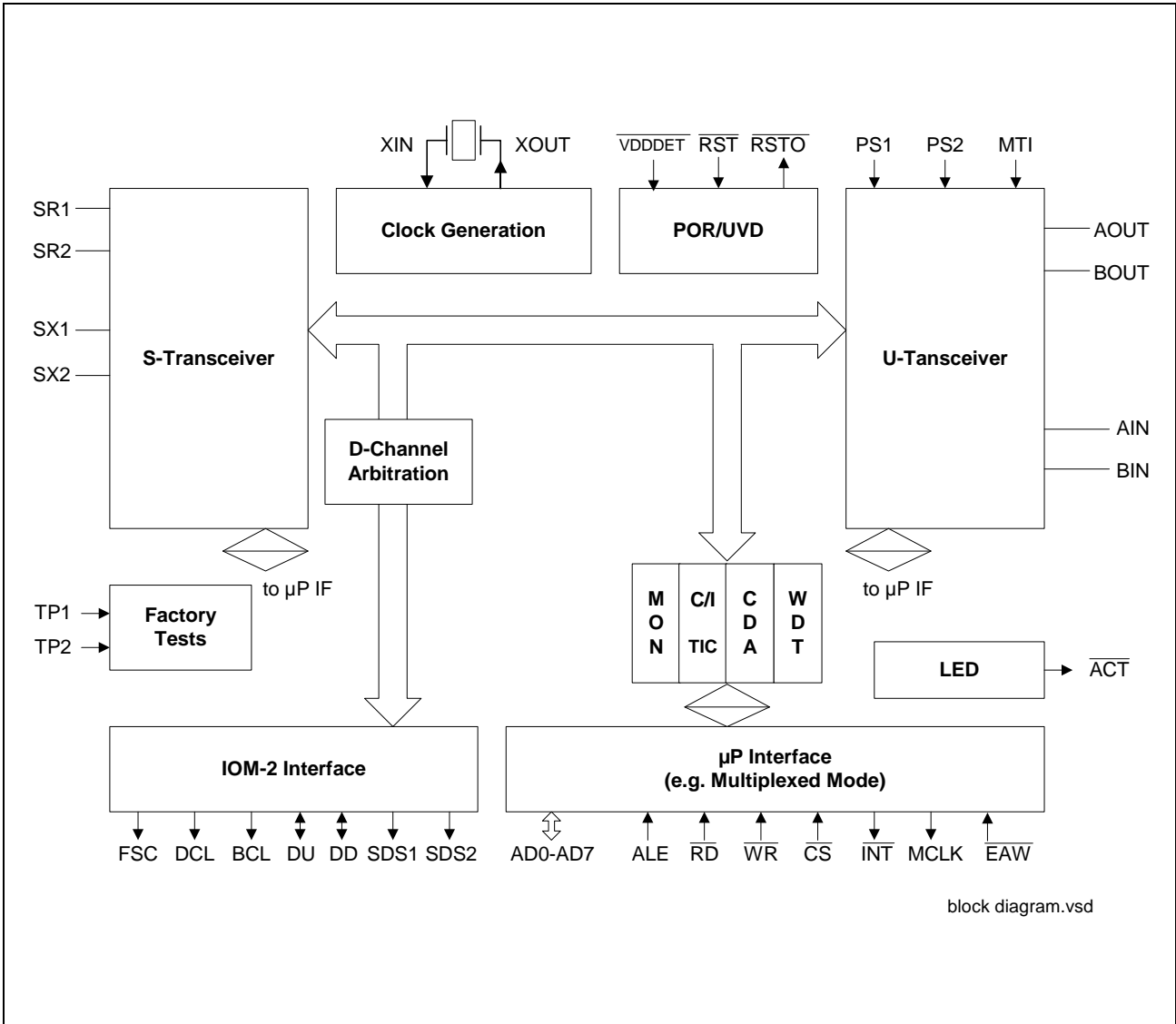

Figure 2 Block Diagram

1.7 Pin Definitions and Functions

Table 2 Pin Definitions and Functions

	Pin	Symbol	Type	Function
	2	VDDa_UR	–	Supply voltage for U-Receiver (3.3 V ± 5 %)
	1	VSSa_UR	–	Analog ground (0 V) U-Receiver
	62	VDDa_UX	–	Supply voltage for U-Transmitter (3.3 V ± 5 %)
	63	VSSa_UX	–	Analog ground (0 V) U-Transmitter
	51	VDDa_SR	–	Supply voltage for S-Receiver (3.3 V ± 5 %)
	52	VSSa_SR	–	Analog ground (0 V) S-Receiver
	46	VDDa_SX	–	Supply voltage for S-Transmitter (3.3 V ± 5 %)
	45	VSSa_SX	–	Analog ground (0 V) S-Transmitter
	29	VDDD	–	Supply voltage digital circuits (3.3 V ± 5 %)
	30	VSSD	–	Ground (0 V) digital circuits
	13	VDDD	–	Supply voltage digital circuits (3.3 V ± 5 %)
	14	VSSD	–	Ground (0 V) digital circuits
	32	FSC	O	Frame Sync: 8-kHz frame synchronization signal
	31	DCL	O	Data Clock: IOM [®] -2 interface clock signal (double clock): 1.536 MHz
	35	BCL	O	Bit Clock: The bit clock is identical to the IOM [®] -2 data rate (768 kHz)
	33	DD	I/O OD	Data Downstream: Data on the IOM [®] -2 interface
	34	DU	I/O OD	Data Upstream: Data on the IOM [®] -2 interface

Overview

Table 2 Pin Definitions and Functions (cont'd)

Pin	Symbol	Type	Function
8	SDS1	O	Serial Data Strobe1: Programmable strobe signal for time slot and/or D-channel indication on IOM [®] -2
7	SDS2	O	Serial Data Strobe2: Programmable strobe signal for time slot and/or D-channel indication on IOM [®] -2
12	$\overline{\text{CS}}$	I	Chip Select: A low level indicates a microcontroller access to the Q-SMINT [®] I
26	SCLK	I	Serial Clock: Clock signal of the SCI interface if a serial interface is selected
26	AD5	I/O	Multiplexed Bus Mode: Address/data bus Address/data line AD5 if the parallel interface is selected Non-Multiplexed Bus Mode: Data bus Data line D5 if the parallel interface is selected
27	SDR	I	Serial Data Receive: Receive data line of the SCI interface if a serial interface is selected
27	AD6	I/O	Multiplexed Bus Mode: Address/data bus Address/data line AD6 if the parallel interface is selected Non-Multiplexed Bus Mode: Data bus Data line D6 if the parallel interface is selected

Table 2 Pin Definitions and Functions (cont'd)

	Pin	Symbol	Type	Function
	28	SDX	OD,O	Serial Data Transmit: Transmit data line of the SCI interface if a serial interface is selected
	28	AD7	I/O	Multiplexed Bus Mode: Address/data bus Address/data line AD7 if the parallel interface is selected Non-Multiplexed Bus Mode: Data bus Data line D7 if the parallel interface is selected
	21 22 23 24 25	AD0 AD1 AD2 AD3 AD4	I/O I/O I/O I/O I/O	Multiplexed Bus Mode: Address/data bus Transfers addresses from the microcontroller to the Q-SMINT [®] I and data between the microcontroller and the Q-SMINT [®] I. Non-Multiplexed Bus Mode: Data bus. Transfers data between the microcontroller and the Q-SMINT [®] I (data lines D0-D4).
	36 37 38 39 40 53 54	A0 A1 A2 A3 A4 A5 A6	I I I I I I I	Non-Multiplexed Bus Mode: Address bus transfers addresses from the microcontroller to the Q-SMINT [®] I. For indirect address mode only A0 is valid. Multiplexed Bus Mode Not used in multiplexed bus mode. In this case A0-A6 should directly be connected to VDD.
	11	$\overline{\text{RD}}$ $\overline{\text{DS}}$	I I	Read Indicates a read access to the registers (Intel bus mode). Data Strobe The rising edge marks the end of a valid read or write operation (Motorola bus mode).

Overview

Table 2 Pin Definitions and Functions (cont'd)

Pin	Symbol	Type	Function
10	\overline{WR}	I	Write Indicates a write access to the registers (Intel bus mode).
	R/\overline{W}	I	Read/Write A HIGH identifies a valid host access as a read operation and a LOW identifies a valid host access as a write operation (Motorola bus mode).
9	ALE	I	Address Latch Enable An address on the external address/data bus (multiplexed bus type only) is latched with the falling edge of ALE. ALE also selects the microcontroller interface type (multiplexed or non multiplexed).
5	\overline{RST}	I	Reset: Low active reset input. Schmitt-Trigger input with hysteresis of typical 360 mV. Tie to '1' if not used.
6	\overline{RSTO}	OD	Reset Output: Low active reset output.
15	\overline{INT}	OD	Interrupt Request: \overline{INT} becomes active if the Q-SMINT [®] I requests an interrupt.
18	MCLK	O	Microcontroller Clock: Clock output for the microcontroller
19			Tie to '1'
20	\overline{EAW}	I	External Awake: A low level on \overline{EAW} during power down activates the clock generation of the Q-SMINT [®] I, i.e. the IOM [®] -2 interface provides FSC, DCL and BCL for read and write access. ¹⁾
43	SX1	O	S-Bus Transmitter Output (positive)
44	SX2	O	S-Bus Transmitter Output (negative)
47	SR1	I	S-Bus Receiver Input

Overview

Table 2 Pin Definitions and Functions (cont'd)

	Pin	Symbol	Type	Function
	48	SR2	I	S-Bus Receiver Input
	60	XIN	I	Crystal 1: Connected to a 15.36 MHz crystal
	59	XOUT	O	Crystal 2: Connected to a 15.36 MHz crystal
	64	AOUT	O	Differential U-interface Output
	61	BOUT	O	Differential U-interface Output
	3	AIN	I	Differential U-interface Input
	4	BIN	I	Differential U-interface Input
	49	$\overline{\text{VDDDET}}$	I	VDD Detection: This pin selects if the V_{DD} detection is active ('0') and reset pulses are generated on pin $\overline{\text{RSTO}}$ or whether it is deactivated ('1') and an external reset has to be applied on pin $\overline{\text{RST}}$.
	16	MTI	I	Metallic Termination Input. Input to evaluate Metallic Termination pulses. Tie to '1' if not used.
	55	PS1	I	Power Status (primary). The pin status is passed to the overhead bit 'PS1' in the U frame to indicate the status of the primary power supply ('1' = ok).
	41	PS2	I	Power Status (secondary). The pin status is passed to the overhead bit 'PS2' in the U frame to indicate the status of the secondary power supply ('1' = ok).
	17	$\overline{\text{ACT}}$	O	Activation LED. Indicates the activation status of U- and S-transceiver. Can directly drive a LED (4 mA).
	42	TP1	I	Test Pin 1. Used for factory device test. Tie to V_{SS}

Table 2 Pin Definitions and Functions (cont'd)

Pin	Symbol	Type	Function
50	TP2	I	Test Pin 2. Used for factory device test. Tie to V_{SS}
56, 57, 58	res		Reserved

1) This function of pin \overline{EAW} is different to that defined in Ref. [14]

I: Input

O: Output (Push-Pull)

OD: Output (Open Drain)

1.7.1 Specific Pins

LED Pin \overline{ACT}

A LED can be connected to pin \overline{ACT} to display four different states (off, slow flashing, fast flashing, on). It displays the activation status of the U- and S-transceiver according to [Table 3](#). or it is programmable via two bits (LED1 and LED2 in register MODE2).

Table 3 ACT States

Pin \overline{ACT}	LED	U_Deactivated	U_Activated	S_Activated
V_{DD}	off	1	x	x
8Hz	8Hz	0	0	x
1Hz	1Hz	0	1	0
GND	on	0	1	1

with:

U_Deactivated: 'Deactivated State' as defined in [Chapter 2.4.10.5](#). If the 'Simplified State Machine' is selected: 'Deactivated State' and 'IOM[®]-2 Awaked'.

U_Activated: 'Synchronized 1', 'Synchronized 2', 'Wait for ACT', 'Transparent', 'Error S/T', 'Pend. Deact. S/T', 'Pend. Deact. U' as defined in [Chapter 2.4.10.5](#).

S-Activated: 'Activated State' as defined in [Chapter 2.5.5](#).

Note: Optionally, pin \overline{ACT} can drive a second LED with inverse polarity (connect this additional LED to 3.3 V only).

Test Modes

The test patterns on the S-interface ('2 kHz Single Pulses', '96 kHz Continuous Pulses') and on the U-interface ('Data Through', 'Send Single Pulses') are invoked via C/I codes (TM1, TM2, DT, SSP). Setting SRES.RES_U to '1' forces the U-transceiver into test mode 'Quiet Mode' (QM), i.e. the U-transceiver is hardware reset.

1.8 System Integration

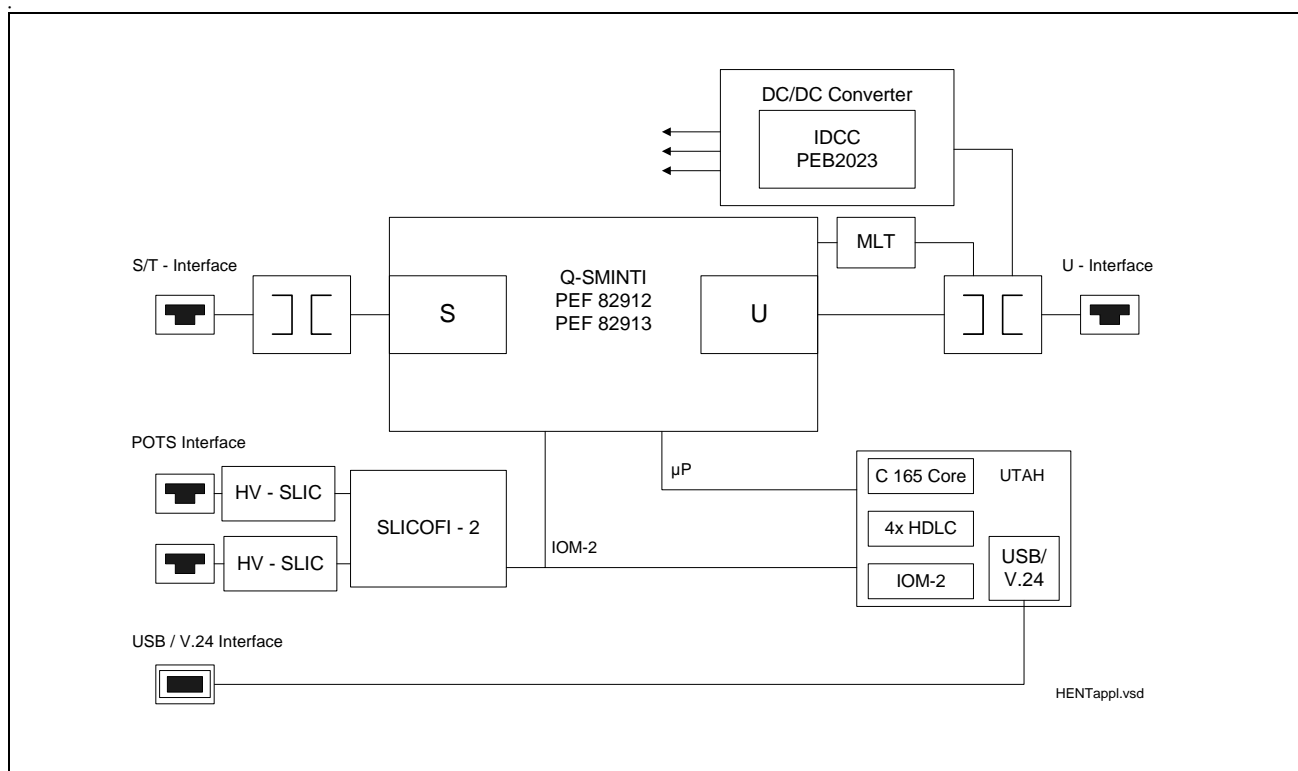

Figure 3 Application Example Q-SMINT[®]I: High Feature Intelligent NT

The U-transceiver, S-transceiver and the IOM[®]-2 channels can be controlled and monitored via:

- a) the parallel or serial microprocessor interface
 - Access of on-chip registers via µP interface Address/Data format
 - Activation/Deactivation control of U- and S-transceiver via µP interface and C/I handler
 - Q-SMINT[®]I is Monitor channel master
 - TIC bus is transparent on IOM[®]-2-interface and is used for D-channel arbitration between S-transceiver and off-chip HDLC controllers.

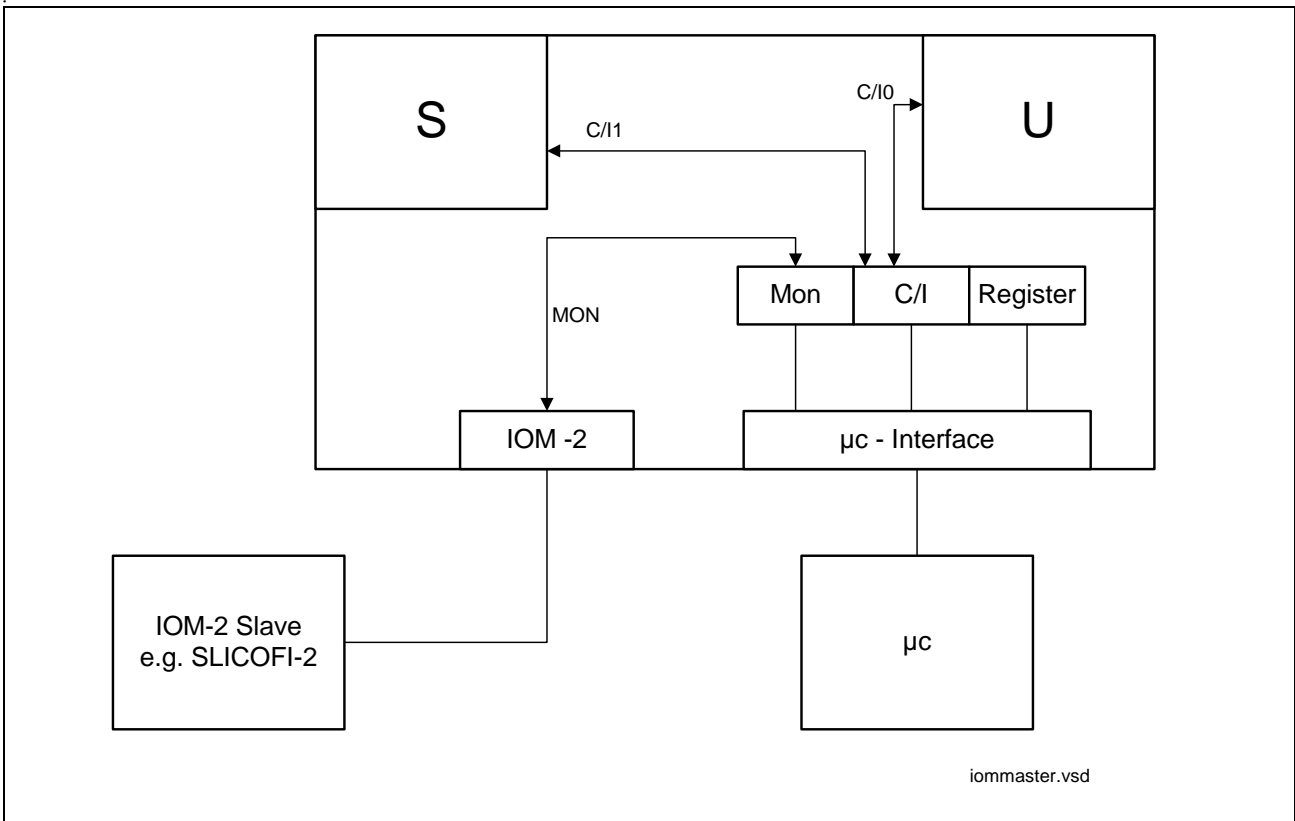

Figure 4 Control via μP Interface

Alternatively, the Q-SMINT[®]I can be controlled via

b) the IOM[®]-2 Interface

- Access of on-chip registers via the Monitor channel with Header/Address/Data format (Device is Monitor slave)
- Activation/Deactivation control of U- and S-transceiver via the C/I channels C/I0 and C/I1
- TIC bus is transparent on IOM[®]-2-interface and is used for D-channel arbitration between S-transceiver and off-chip HDLC controllers.

Overview

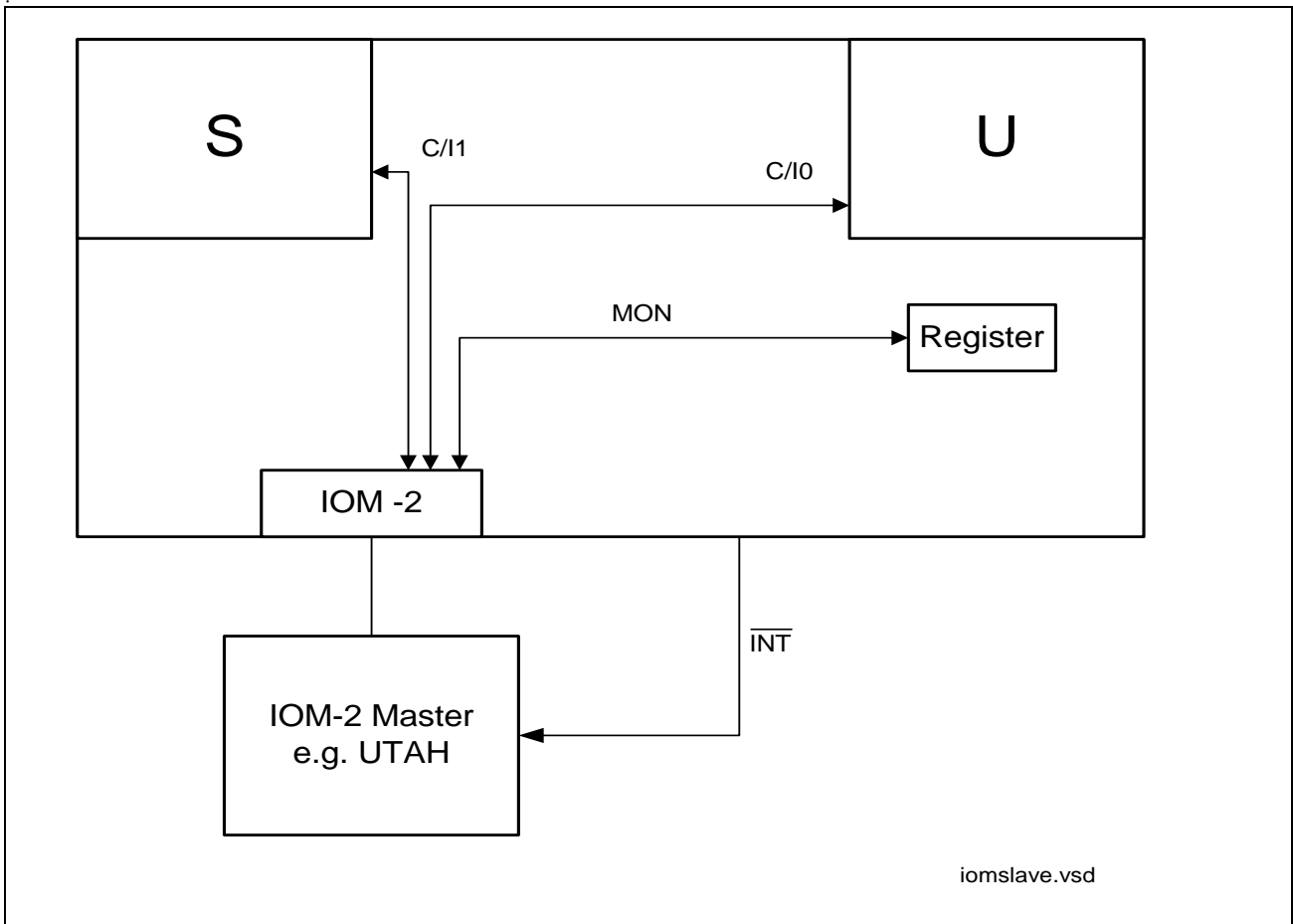

Figure 5 Control via IOM[®]-2 Interface

Functional Description

2 Functional Description

2.1 Microcontroller Interfaces

The Q-SMINT[®]I supports either a serial or a parallel microcontroller interface. For applications where no controller is connected to the Q-SMINT[®]I microcontroller interface, register programming is done via the IOM[®]-2 MONITOR channel from a master device. In such applications the Q-SMINT[®]I operates in the IOM[®]-2 slave mode (refer to the corresponding chapter of the IOM[®]-2 MONITOR handler).

The interface selections are all done by pinstrapping. The possible interface selections are listed in **Table 4**. The selection pins are evaluated when the reset input \overline{RST} is released. For the pin levels stated in the tables the following is defined:

'High':dynamic pin value which must be 'High' when the pin level is evaluated

V_{DD} , V_{SS} :static 'High' or 'Low' level (tied to V_{DD} , V_{SS})

Table 4 Interface Selection for the Q-SMINT[®]I

PINS		Serial/Parallel Interface	PINS		Interface Type/Mode
WR (R/W)	RD (DS)		CS	ALE	
'High'	'High'	Parallel	'High'	V_{DD}	Motorola
				V_{SS}	Siemens/Intel Non-Mux
				edge	Siemens/Intel Mux
V_{SS}	V_{SS}	Serial	'High'	V_{SS}	Serial Control Interface(SCI)
			V_{SS}	V_{SS}	IOM [®] -2 MONITOR Channel (Slave Mode)

Note: For a selected interface mode which does not require all pins (e.g. address pins) the unused pins must be tied to V_{DD} .

The microcontroller interface also consists of a microcontroller clock generation at pin MCLK, an interrupt request at pin \overline{INT} , a reset input pin \overline{RST} and a reset output pin \overline{RSTO} .

The interrupt request pin \overline{INT} (open drain output) becomes active if the Q-SMINT[®]I requests an interrupt.

Functional Description

2.1.1 Serial Control Interface (SCI)

The serial control interface (SCI) is compatible to the SPI interface of Motorola and to the Siemens C510 family of microcontrollers.

The SCI consists of 4 lines: SCLK, SDX, SDR and \overline{CS} . Data is transferred via the lines SDR and SDX at the rate given by SCLK. The falling edge of \overline{CS} indicates the beginning of a serial access to the registers. The Q-SMINT[®]I latches incoming data at the rising edge of SCLK and shifts out at the falling edge of SCLK. Each access must be terminated by a rising edge of \overline{CS} . Data is transferred in groups of 8 bits with the MSB first.

Pad mode of SDX can be selected 'open drain' or 'push-pull' by programming MODE2.PPSDX.

Figure 6 shows the timing of a one byte read/write access via the serial control interface.

Functional Description

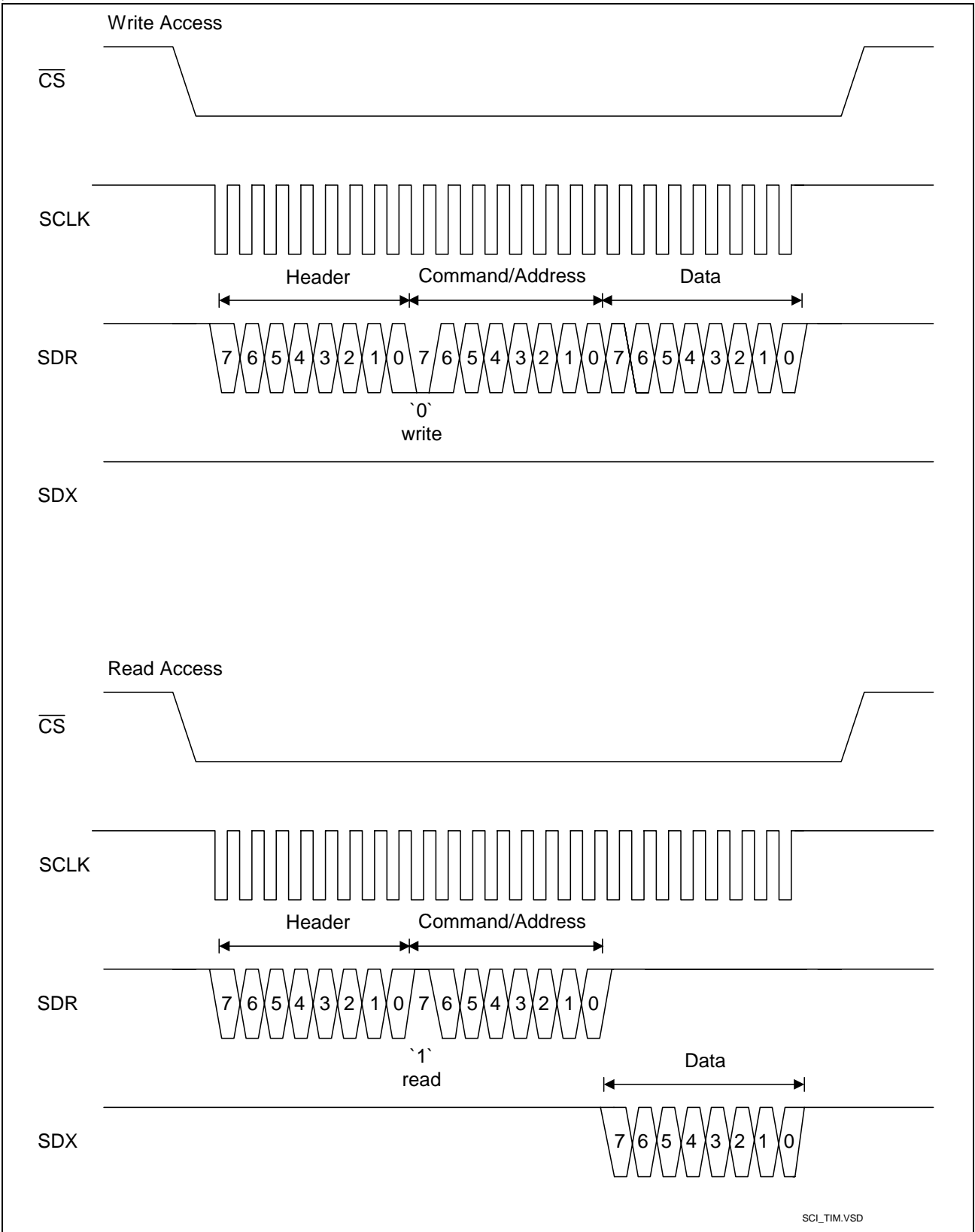

Figure 6 Serial Control Interface Timing

Functional Description

2.1.1.1 Programming Sequences

The basic structure of a read/write access to the Q-SMINT[®]I registers via the serial control interface is shown in **Figure 7**.

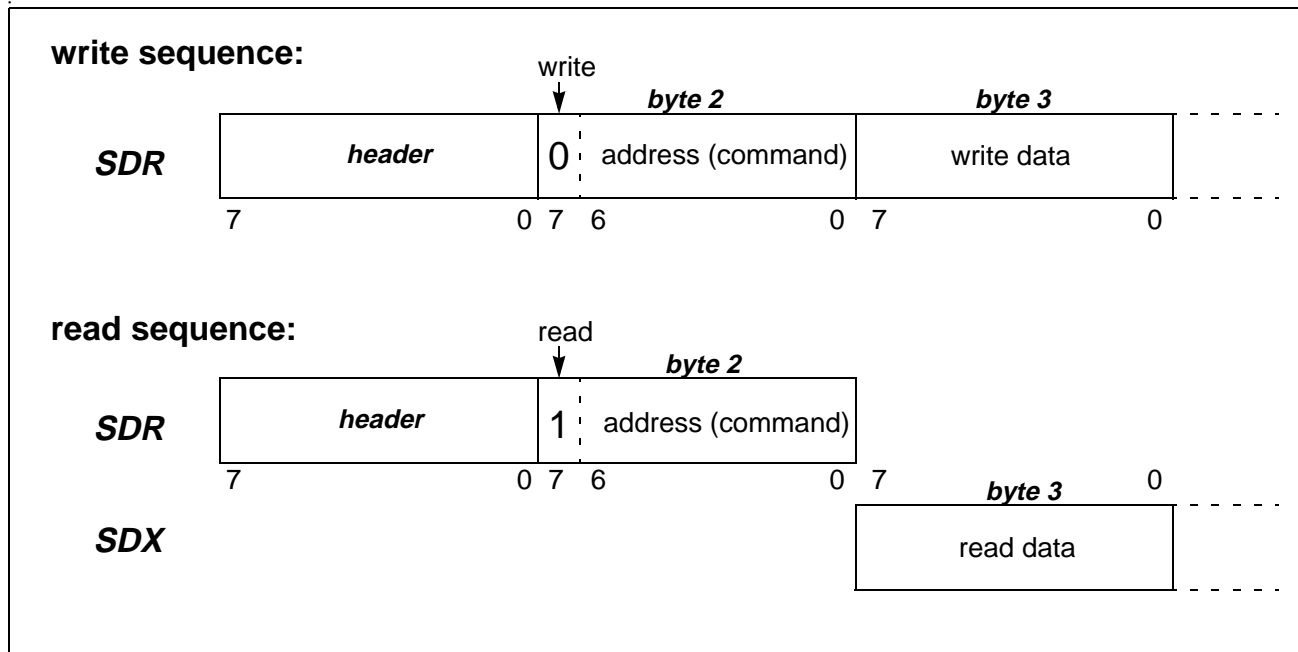

Figure 7 Serial Command Structure

A new programming sequence starts with the transfer of a header byte. The header byte specifies different programming sequences allowing a flexible and optimized access to the individual functional blocks of the Q-SMINT[®]I.

The possible sequences are listed in **Table 5** and are described after that.

Table 5 Header Byte Code

Header Byte	Sequence	Sequence Type	Access to
40 _H	Adr-Data-Adr-Data	non-interleaved	Address Range 00 _H -7F _H
48 _H		interleaved	
43 _H	Adr-Data-Data-Data	Read-/Write-only	Address Range 00 _H -7F _H
41 _H		non-interleaved	
49 _H		interleaved	

Functional Description

Header 40_H: Non-interleaved A-D-A-D Sequences

The non-interleaved A-D-A-D sequences give direct read/write access to the address range 00_H-7F_H and can have any length. In this mode SDX and SDR can be connected together allowing data transmission on one line.

Example for a read/write access with header 40_H:

SDR	header	wradr	wrdata	rdadr		rdadr		wradr	wrdata	
SDX					rddata		rddata			

Header 48_H: Interleaved A-D-A-D Sequences

The interleaved A-D-A-D sequences give direct read/write access to the address range 00_H-7F_H and can have any length. This mode allows a time optimized access to the registers by interleaving the data on SDX and SDR.

Example for a read/write access with header 48_H:

SDR	header	wradr	wrdata	rdadr	rdadr	wradr	wrdata			
SDX					rddata	rddata				

Header 43_H: Read-/Write- only A-D-D-D Sequence

Generally, it can be used for any register access to the address range 20_H-7D_H. The sequence can have any length and is terminated by the rising edge of \overline{CS} .

Example for a write access with header 43_H:

SDR	header	wradr	wrdata (wradr)	wrdata (wradr)	wrdata (wradr)	wrdata (wradr)	wrdata (wradr)	wrdata (wradr)	wrdata (wradr)	
SDX										

Example for a read access with header 43_H:

SDR	header	rdadr								
SDX			rddata (rdadr)	rddata (rdadr)	rddata (rdadr)	rddata (rdadr)	rddata (rdadr)	rddata (rdadr)	rddata (rdadr)	rddata (rdadr)

Functional Description

Header 41_H: Non-interleaved A-D-D-D Sequence

This sequence (header 41_H) allows in front of the A-D-D-D write access a non-interleaved A-D-A-D read access. Generally, it can be used for any register access to the address range 20_H-7D_H. The termination condition of the read access is the reception of the wradr. The sequence can have any length and is terminated by the rising edge of \overline{CS} .

Example for a read/write access with header 41_H:

SDR	header	rdadr		rdadr		wradr	wrdata (wradr)	wrdata (wradr)	wrdata (wradr)	
SDX			rddata		rddata					

Header 49_H: Interleaved A-D-D-D Sequence

This sequence (header 49_H) allows in front of the A-D-D-D write access an interleaved A-D-A-D read access. Generally, it can be used for any register access to the address range 20_H-7D_H. The termination condition of the read access is the reception of the wradr. The sequence can have any length and is terminated by the rising edge of \overline{CS} .

Example for a read/write access with header 49_H:

SDR	header	rdadr	rdadr	wradr	wrdata (wradr)	wrdata (wradr)	wrdata (wradr)			
SDX			rddata	rddata						

2.1.2 Parallel Microcontroller Interface

The 8-bit parallel microcontroller interface with address decoding on chip allows an easy and fast microcontroller access.

The parallel interface of the Q-SMINT[®]I provides three types of μ P busses which are selected via pin ALE. The bus operation modes with corresponding control pins are listed in [Table 6](#).

Table 6 Bus Operation Modes

	Bus Mode	Pin ALE	Control Pins
(1)	Motorola	V _{DD}	\overline{CS} , $\overline{R\overline{W}}$, \overline{DS}
(2)	Siemens/Intel non-multiplexed	V _{SS}	\overline{CS} , \overline{WR} , \overline{RD}
(3)	Siemens/Intel multiplexed	Edge	\overline{CS} , \overline{WR} , \overline{RD} , ALE

The occurrence of an edge on ALE, either positive or negative, at any time during the operation immediately selects the interface type (3). A return to one of the other interface types is possible only if a hardware reset is issued.

Functional Description

Note: For a selected interface mode which does not require all pins (e.g. address pins) the unused pins must be tied to V_{DD} .

A read/write access to the Q-SMINT[®]I registers can be done in **multiplexed or non-multiplexed** mode.

In non-multiplexed mode the register address must be applied to the address bus (A0-A6) for the data access via the data bus (D0-D7).

In multiplexed mode the address on the address bus (AD0-AD7) is latched in by ALE before a read/write access via the address/data bus is performed.

The Q-SMINT[®]I provides two different ways to address the register contents which can be selected with the AMOD bit in the MODE2 register. The address mode after reset is the indirect address mode (AMOD = '0'). Reprogramming into the direct address mode (AMOD = '1') has to take place in the indirect address mode. **Figure 8** illustrates both register addressing modes.

Direct address mode (AMOD = '1'): The register address to be read or written is directly set in the way described above.

Indirect address mode (AMOD = '0'):

- non-muxed: only the LSB of the address bus (A0)
- muxed: only the LSB of the address-data bus (AD0)

gets evaluated to address a virtual ADDRESS (0_H) and a virtual DATA (1_H) register.

Every access to a target register consists of:

- a write access (muxed or non-muxed) to ADDRESS to store the target register's address, as well as
- a read access (muxed or non-muxed) from DATA to read from the target register or
- a write access (muxed or non-muxed) to DATA to write to the target register

Functional Description

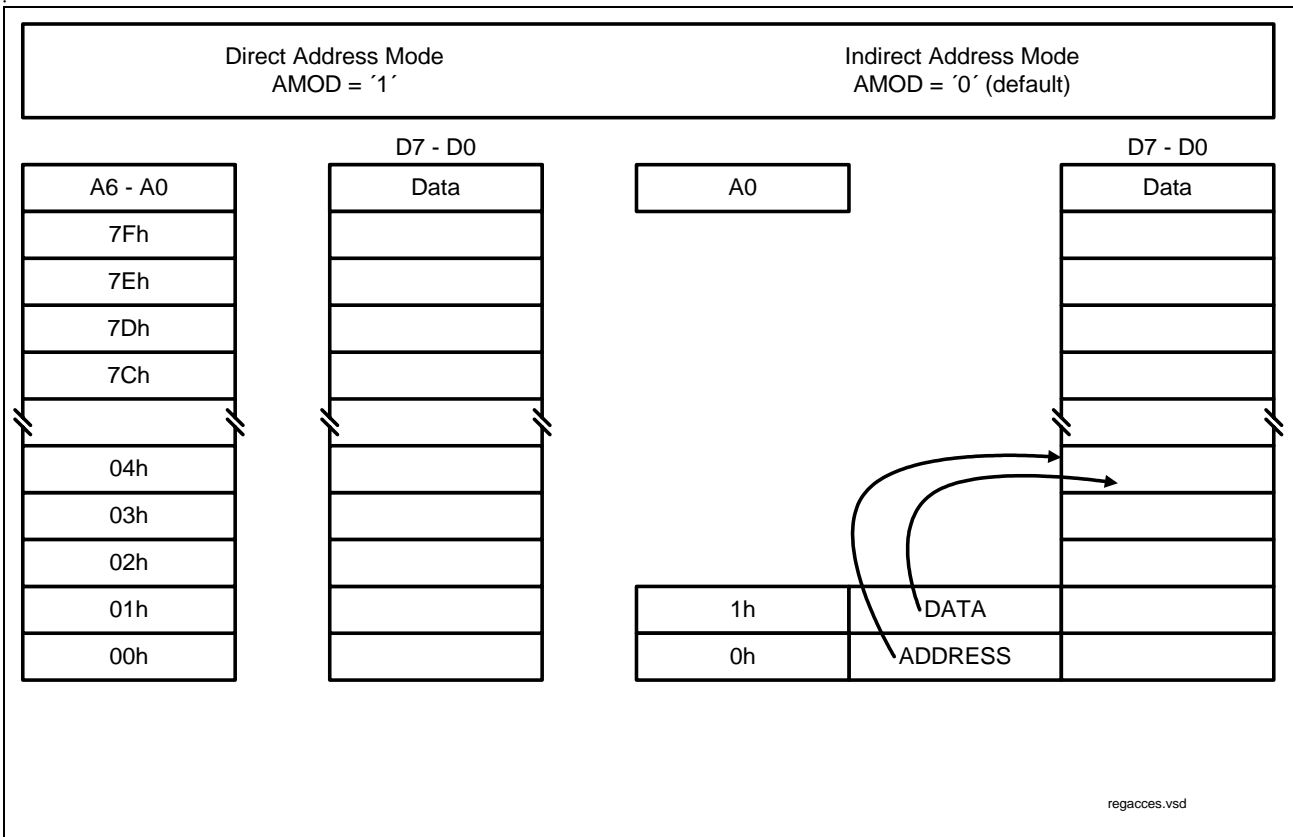

Figure 8 Direct/Indirect Register Address Mode

2.1.3 Microcontroller Clock Generation

The microcontroller clock is derived from the unregulated 15.36 MHz clock from the oscillator and provided by the pin MCLK. Five clock rates are selectable by a programmable prescaler which is controlled by the bits MODE1.MCLK and MODE1.CDS corresponding to the following table.

Table 7 MCLK Frequencies

MODE1.MCLK Bits		MCLK frequency with MODE1.CDS = '0'	MCLK frequency with MODE1.CDS = '1'
0	0	3.84 MHz	7.68 MHz
0	1	0.96 MHz	1.92 MHz
1	0	7.68 MHz	15.36 MHz
1	1	disabled	disabled

The clock rate is changed after \overline{CS} becomes inactive.

Functional Description

2.2 Reset Generation

Figure 9 shows the organization of the reset generation of the Q-SMINT® I.

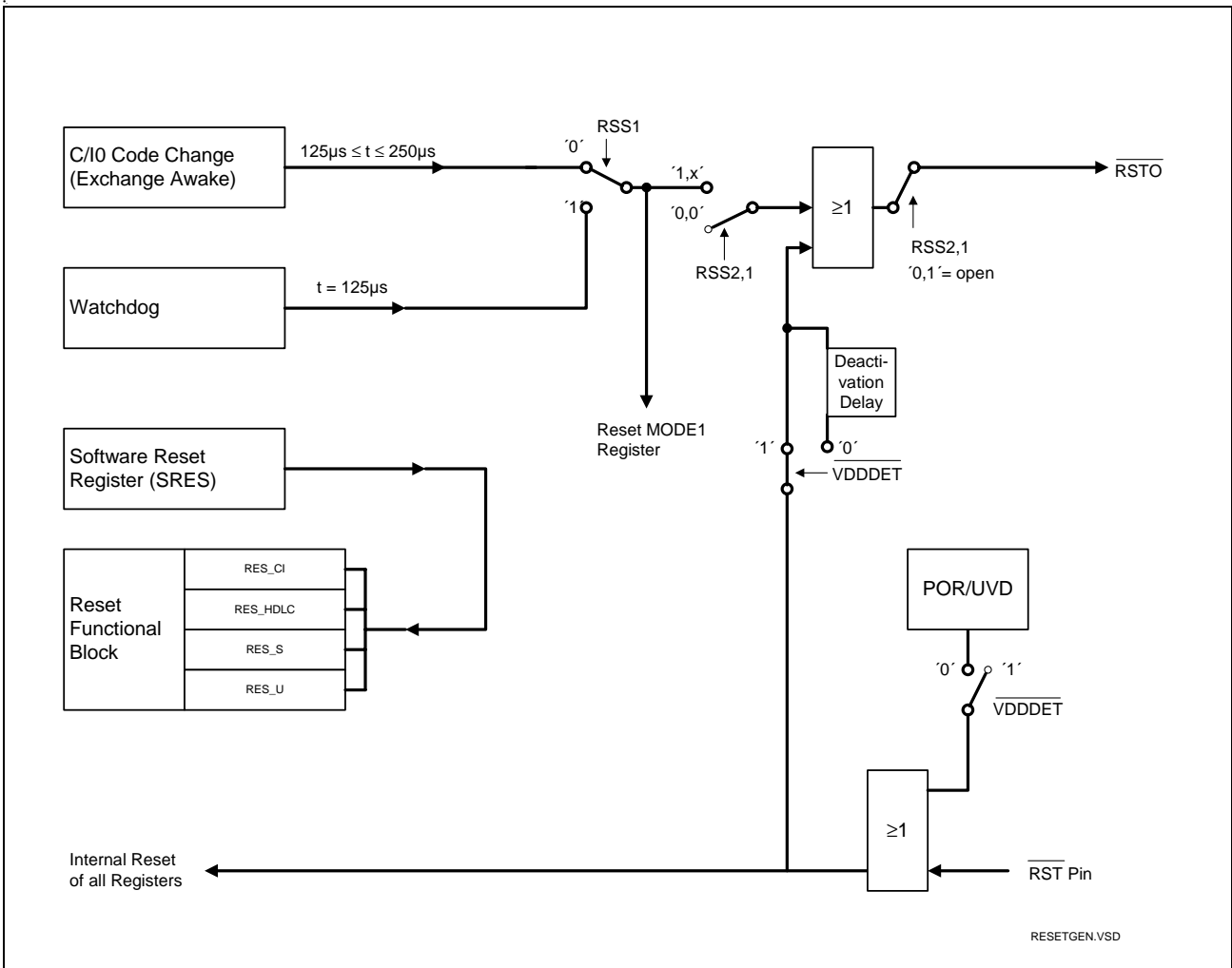

Figure 9 Reset Generation of the Q-SMINT® I¹⁾

Reset Source Selection

The internal reset sources C/I code change and Watchdog timer can be output at the low active reset pin \overline{RSTO} . These reset sources can be selected with the RSS2,1 bits in the MODE1 register according to Table 8.

¹⁾ The 'OR'-gates shall illustrate in a symbolic way, that 'source A active' or 'source B active' is forwarded. The real polarity of the different sources is not considered.

Functional Description

The internal reset sources set the MODE1 register to its reset value.

Table 8 Reset Source Selection

RSS2 Bit 1	RSS1 Bit 0	C/I Code Change	Watchdog Timer	POR/UVD ¹⁾ and $\overline{\text{RST}}$
0	0	--	--	x
0	1	/RSTO disabled (= high impedance)		
1	0	x	--	x
1	1	--	x	x

1) POR/UVD can be enabled/disabled via pin $\overline{\text{VDDDET}}$

- **C/I Code Change (Exchange Awake)**

A change in the downstream C/I channel (C/I0) generates a reset pulse of $125 \mu\text{s} \leq t \leq 250 \mu\text{s}$.

- **Watchdog Timer**

After the selection of the watchdog timer (RSS = '11') an internal timer is reset and started. During every time period of 128 ms the microcontroller has to program the WTC1- and WTC2 bits in the following sequence to reset and restart the watchdog timer:

	WTC1	WTC2
1.	1	0
2.	0	1

Otherwise the timer expires and a WOV-interrupt (ISTA Register) together with a reset out pulse on pin $\overline{\text{RSTO}}$ of $125 \mu\text{s}$ is generated.

Deactivation of the watchdog timer is only possible with a hardware reset (including expiration of the watchdog timer).

As in the SCOUT-S, the watchdog timer is clocked with the IOM[®]-2 clocks and works only if the internal IOM[®]-2 clocks are active. Hence, the power consumption is minimized in state power down.

Software Reset Register (SRES)

Several main functional blocks of the Q-SMINT[®]I can be reset separately by software setting the corresponding bit in the SRES register. This is equivalent to a hardware reset of the corresponding functional block. The reset state is activated as long as the bit is set to '1'.

Functional Description

External Reset Input

At the $\overline{\text{RST}}$ input an external reset can be applied forcing the Q-SMINT[®]I in the reset state. This external reset signal is additionally fed to the $\overline{\text{RSTO}}$ output.

After release of an external reset, the μC has to wait for min. $t_{\mu\text{C}}$ before it starts read or write access to the Q-SMINT[®]I (see [Table 40](#)).

Reset Output

If $\overline{\text{VDDDET}}$ is active, then the deactivation of a reset output on $\overline{\text{RSTO}}$ is delayed by t_{DEACT} (see [Table 41](#)).

Reset Generation

The Q-SMINT[®]I has an on-chip reset generator based on a Power-On Reset (POR) and Under Voltage Detection (UVD) circuit (see [Table 41](#)). The POR/UVD requires no external components.

The POR/UVD circuit can be disabled via pin $\overline{\text{VDDDET}}$.

The requirements on V_{DD} ramp-up during power-on reset are described in [Chapter 5.6.5](#).

Clocks and Data Lines During Reset

During reset the data clock (DCL), the bit clock (BCL), the microcontroller clock¹⁾ (MCLK) and the frame synchronization (FSC) keep running.

During reset DD and DU are high; with the exception of:

- The output C/I code from the U-Transceiver on DD IOM[®]-2 channel 0 is 'DR' = 0000 (Value after reset of register UCIR = '00_H')
- The output C/I code from the S-Transceiver on DU IOM[®]-2 channel 1 is 'TIM' = 0000.

¹⁾ during a Power-On/UVD Reset, the microcontroller clock MCLK is not running, but starts running as soon as timer t_{DEAC} is started.

Functional Description

2.3 IOM[®]-2 Interface

The Q-SMINT[®]I supports the IOM[®]-2 interface in terminal mode (DCL=1.536 MHz) according to the IOM[®]-2 Reference Guide [13].

2.3.1 IOM[®]-2 Functional Description

The IOM[®]-2 interface consists of four lines: FSC, DCL, DD, DU and optionally BCL. The rising edge of FSC indicates the start of an IOM[®]-2 frame. The DCL and the BCL clock signals synchronize the data transfer on both data lines DU and DD. The DCL is twice the bit rate, the BCL rate is equal to the bit rate. The bits are shifted out with the rising edge of the first DCL clock cycle and sampled at the falling edge of the second clock cycle. With BCL the bits are shifted out with the rising edge and sampled with the falling edge of the single clock cycle.

The IOM[®]-2 interface can be enabled/disabled with the DIS_IOM bit in the IOM_CR register.

The FSC signal is an 8 kHz frame sync signal. The number of PCM timeslots on the receive and transmit lines is determined by the frequency of the DCL clock (or BCL), with the 1.536 MHz (BCL=768 kHz) clock 3 channels consisting of 4 timeslots each are available.

IOM[®]-2 Frame Structure of the Q-SMINT[®]I

The frame structure on the IOM[®]-2 data ports (DU,DD) of the Q-SMINT[®]I with a DCL clock of 1.536 MHz (or BCL=768 kHz) and if TIC bus is not disabled (IOM_CR.TIC_DIS) is shown in **Figure 10**.

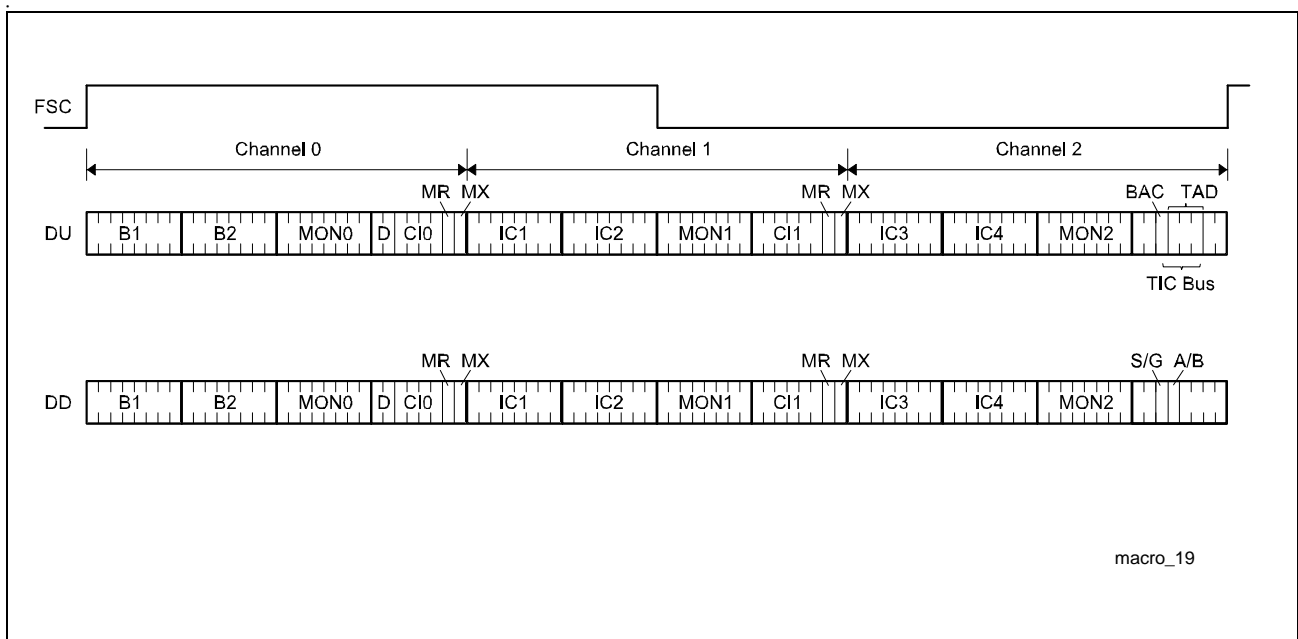

Figure 10 IOM[®]-2 Frame Structure of the Q-SMINT[®]I

Functional Description

The frame is composed of three channels

- Channel 0 contains 144-kbit/s of user and signaling data (2B + D), a MONITOR programming channel (MON0) and a command/indication channel (CI0) for control and programming of e.g. the U-transceiver.
- Channel 1 contains two 64-kbit/s intercommunication channels (IC), a MONITOR programming channel (MON1) and a command/indication channel (CI1) for control and programming of e.g. the S-transceiver.
- Channel 2 is used for D-channel access mechanism (TIC-bus, S/G bit). Additionally, channel 2 supports further IC and MON channels.

2.3.2 IOM[®]-2 Handler

The IOM[®]-2 handler offers a great flexibility for handling the data transfer between the different functional units of the Q-SMINT[®]I and voice/data devices connected to the IOM[®]-2 interface. Additionally it provides a microcontroller access to all time slots of the IOM[®]-2 interface via the four controller data access registers (CDA).

The PCM data of the functional units

- S-transceiver (S) and the
- Controller data access (CDA)

can be configured by programming the time slot and data port selection registers (TSDP). With the TSS bits (Time Slot Selection) the PCM data of the functional units can be assigned to each of the 12 PCM time slots of the IOM[®]-2 frame. With the DPS bit (Data Port Selection) the output of each functional unit is assigned to DU or DD respectively. The input is assigned vice versa. With the control registers (CR) the access to the data of the functional units can be controlled by setting the corresponding control bits (EN, SWAP).

The IOM[®]-2 handler also provides access to the

- U and S transceiver
- MONITOR channel
- C/I channels (CI0,CI1)
- TIC bus (TIC)

The access to these channels is controlled by the registers S_CR, CI_CR and MON_CR. The IOM[®]-2 interface with the two Serial Data Strobes (SDS1,2) is controlled by the control registers IOM_CR, SDS1_CR and SDS2_CR.

The following **Figure 11** shows the architecture of the IOM[®]-2 handler.

Functional Description

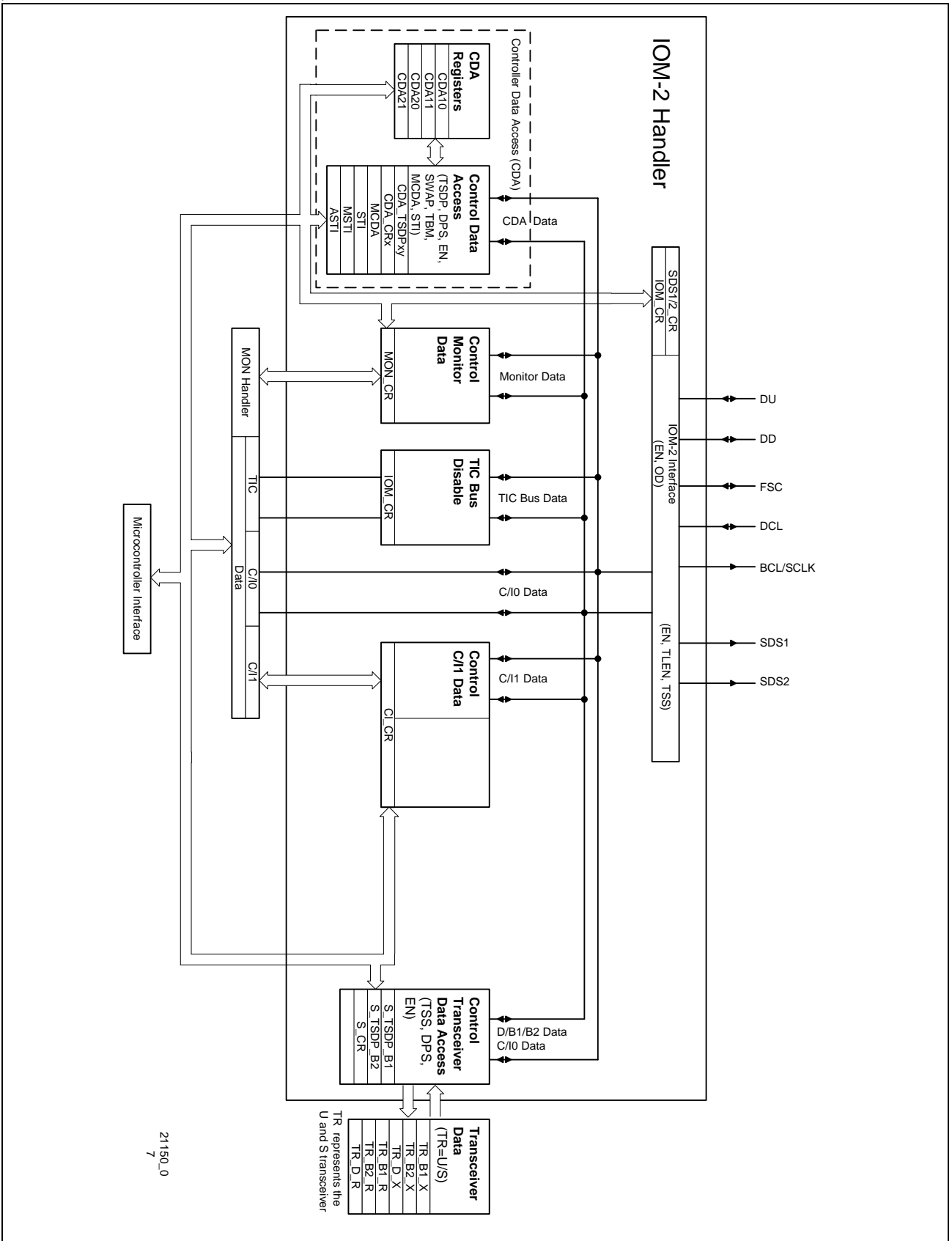

Figure 11 Architecture of the IOM[®]-2 Handler

Functional Description

2.3.2.1 Controller Data Access (CDA)

The four controller data access registers (CDA10, CDA11, CDA20, CDA21) provide microcontroller access to the 12 IOM[®]-2 time slots and more:

- looping of up to four independent PCM channels from DU to DD or vice versa over the four CDA registers
- shifting or switching of two independent PCM channels to another two independent PCM channels on both data ports (DU, DD). Between reading and writing the data can be manipulated (processed with an algorithm) by the microcontroller. If this is not the case a switching function is performed.
- monitoring of up to four time slots on the IOM[®]-2 interface simultaneously
- microcontroller read and write access to each PCM channel

The access principle, which is identical for the two channel register pairs CDA10/11 and CDA20/21, is illustrated in [Figure 12](#). The index variables x,y used in the following description can be 1 or 2 for x, and 0 or 1 for y. The prefix 'CDA_' from the register names has been omitted for simplification.

To each of the four CDAXy data registers a TSDPxy register is assigned by which the time slot and the data port can be determined. With the TSS (Time Slot Selection) bits a time slot from 0...11 can be selected. With the DPS (Data Port Selection) bit the output of the CDAXy register can be assigned to DU or DD respectively. The time slot and data port for the output of CDAXy is always defined by its own TSDPxy register. The input of CDAXy depends on the SWAP bit in the control registers CRx.

If the SWAP bit = '0' (swap is disabled) the time slot and data port for the input and output of the CDAXy register is defined by its own TSDPxy register.

If the SWAP bit = '1' (swap is enabled) the input port and time slot of the CDAX0 is defined by the TSDP register of CDAX1 and the input port and time slot of CDAX1 is defined by the TSDP register of CDAX0. The input definition for time slot and data port CDAX0 are thus swapped to CDAX1 and for CDAX1 swapped to CDAX0. The output timeslots are not affected by SWAP.

The input and output of every CDAXy register can be enabled or disabled by setting the corresponding EN (-able) bit in the control register CDAX_CR. If the input of a register is disabled the output value in the register is retained.

Usually one input and one output of a functional unit (transceiver, CDA register) is programmed to a timeslot on IOM[®]-2 (e.g. for B-channel transmission in upstream direction the S-transceiver writes data onto IOM[®]-2 and the U-transceiver reads data from IOM[®]-2). For monitoring data in such cases a CDA register is programmed as described below under "Monitoring Data". Besides that none of the IOM[®]-2 timeslots must be assigned more than one input and output of any functional unit.

Functional Description

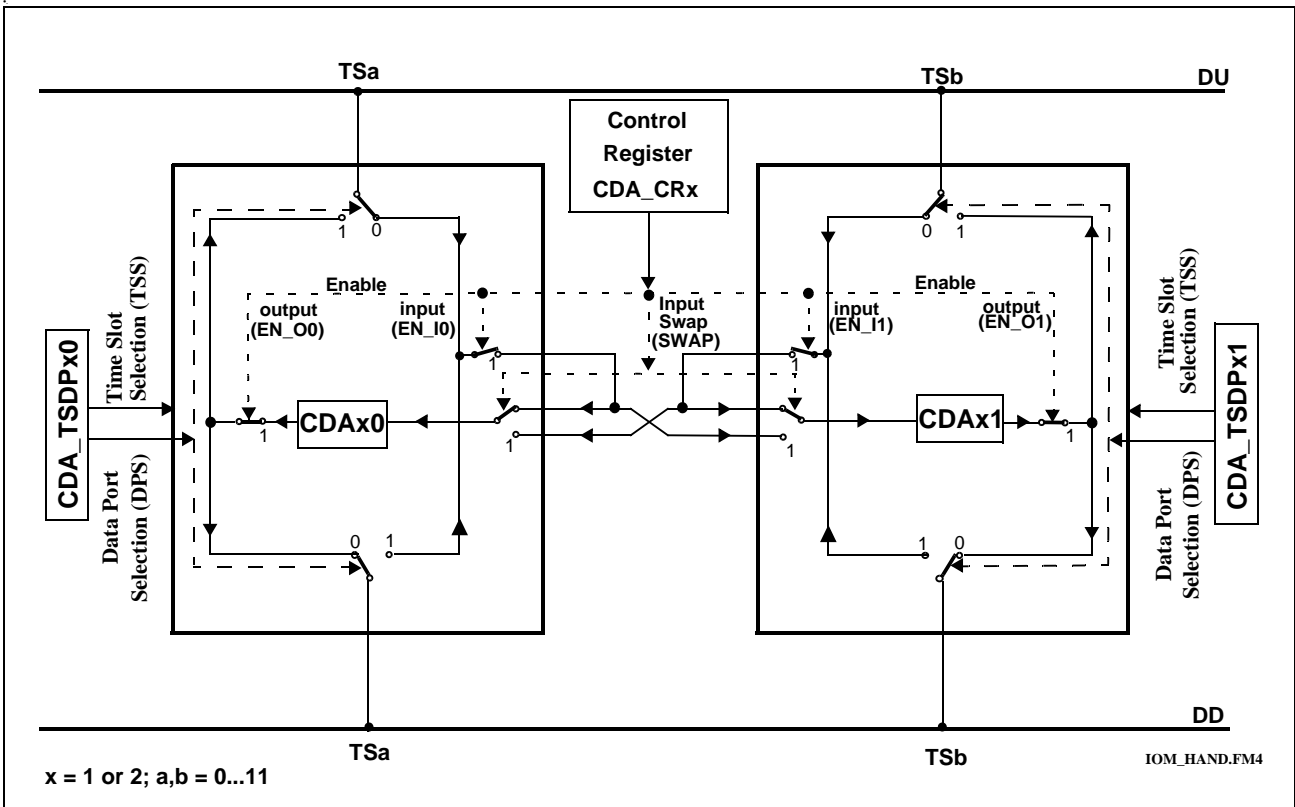

Figure 12 Data Access via CDAX0 and CDAX1 register pairs

Looping and Shifting Data

Figure 13 gives examples for typical configurations with the above explained control and configuration possibilities with the bits TSS, DPS, EN and SWAP in the registers TSDPxy or CDAX_CR:

- a) looping IOM[®]-2 time slot data from DU to DD or vice versa (SWAP = '0')
- b) shifting data from TSa to TSb and TSc to TSd in both transmission directions (SWAP = '1')
- c) switching data from TSa to TSb and looping from DU to DD or switching TSc to TSd and looping from DD to DU .

TSa is programmed in TSDP10, TSb in TSDP11, TSc in TSDP20 and TSd in TSDP21.

Functional Description

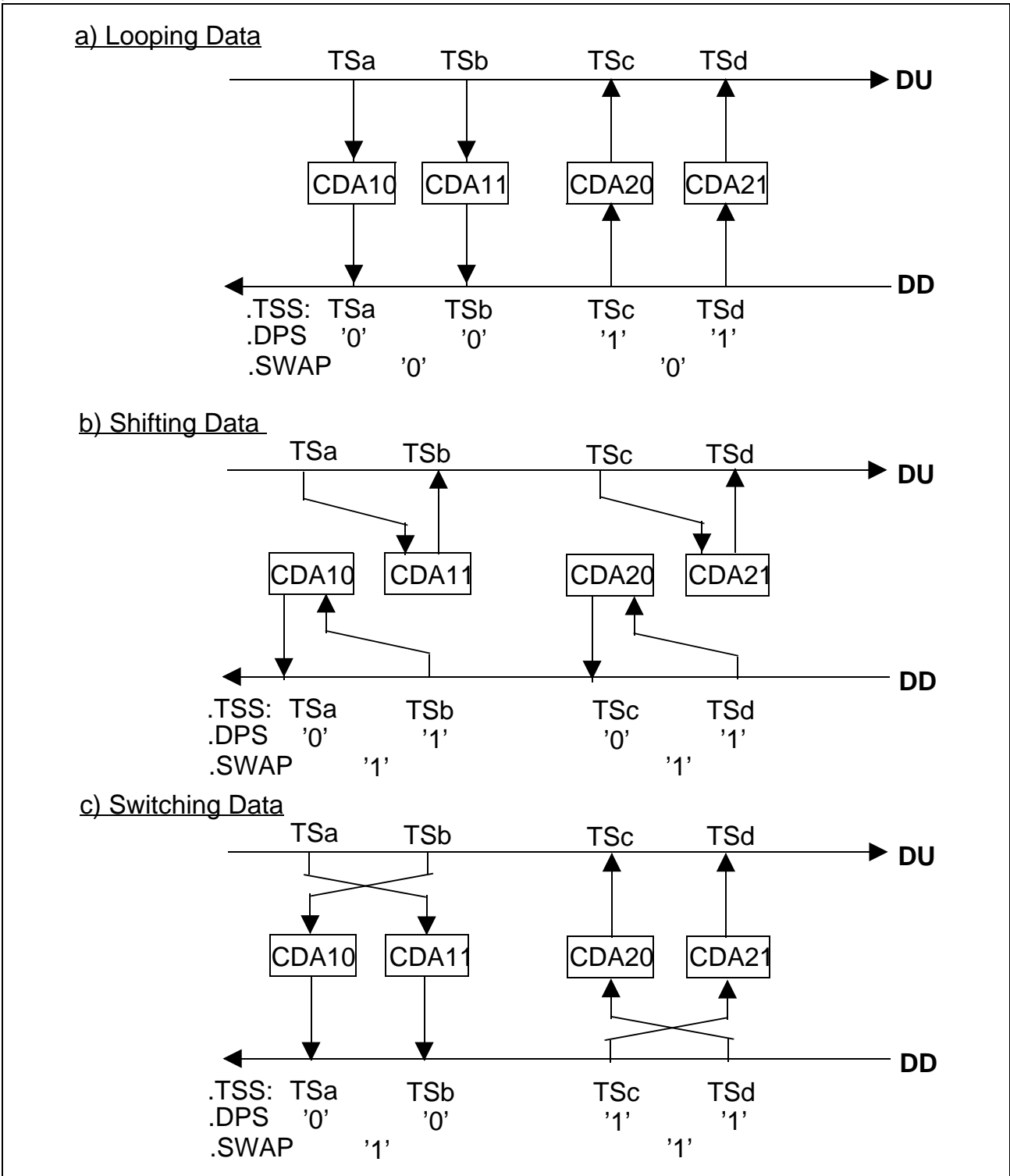

Figure 13 Examples for Data Access via CDAxy Registers

- a) Looping Data
- b) Shifting (Switching) Data
- c) Switching and Looping Data

Functional Description

Figure 14 shows the timing of looping TSa from DU to DD via CDAXy register. TSa is read in the CDAXy register from DU and is written one frame later on DD.

Figure 15 shows the timing of shifting data from TSa to TSb on DU(DD). In **Figure 15a**) shifting is done in one frame because TSa and TSb didn't succeed directly one another ($a = 0\dots9$ and $b \geq a+2$). In **Figure 15b**) shifting is done from one frame to the following frame. This is the case when the time slots succeed one other ($b = a+1$) or b is smaller than a ($b < a$).

At looping and shifting the data can be accessed by the controller between the synchronous transfer interrupt (STI) and the status overflow interrupt (STOV). STI and STOV are explained in the section 'Synchronous Transfer'. If there is no controller intervention the looping and shifting is done autonomously.

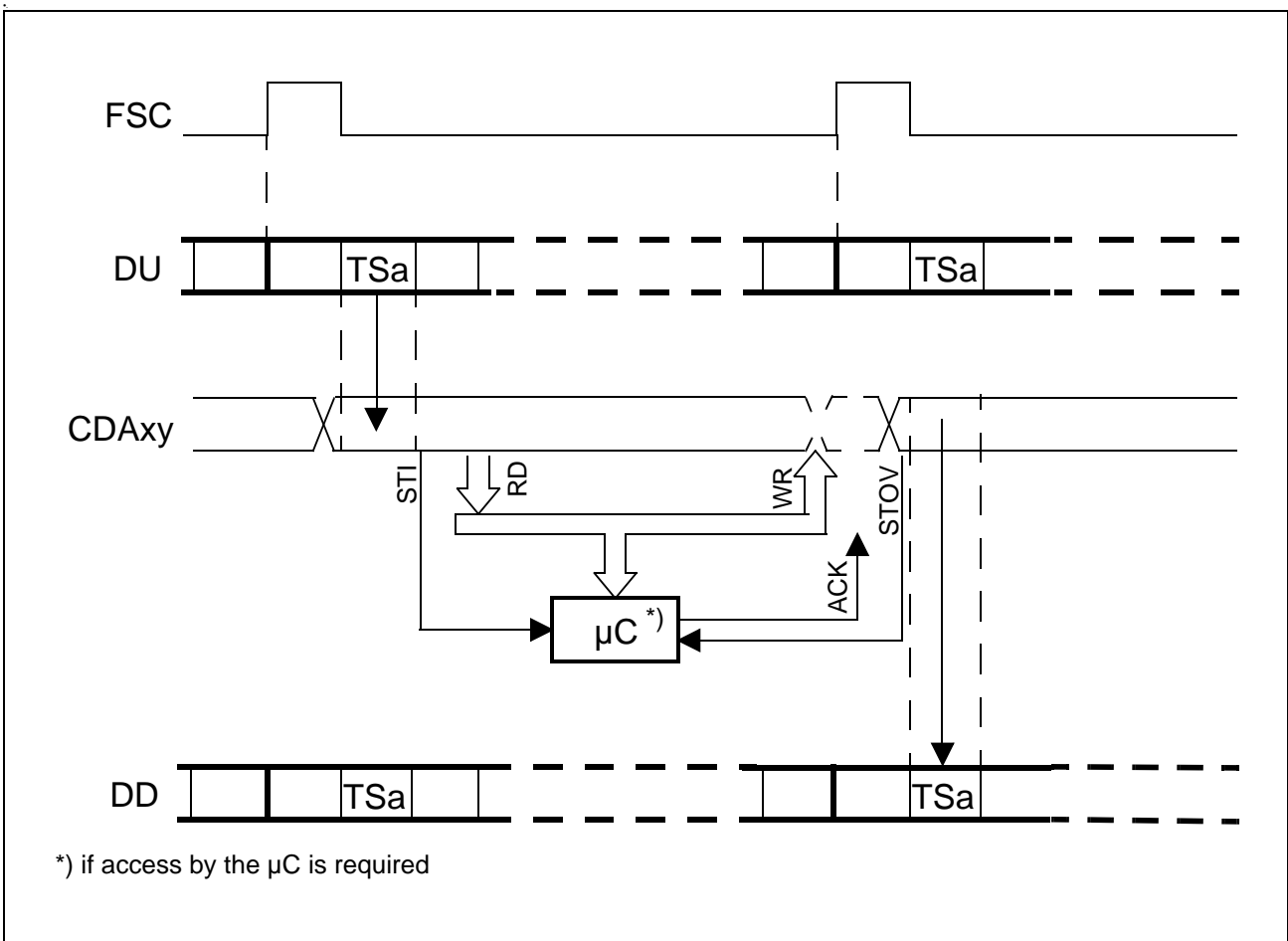

Figure 14 Data Access when Looping TSa from DU to DD

Functional Description

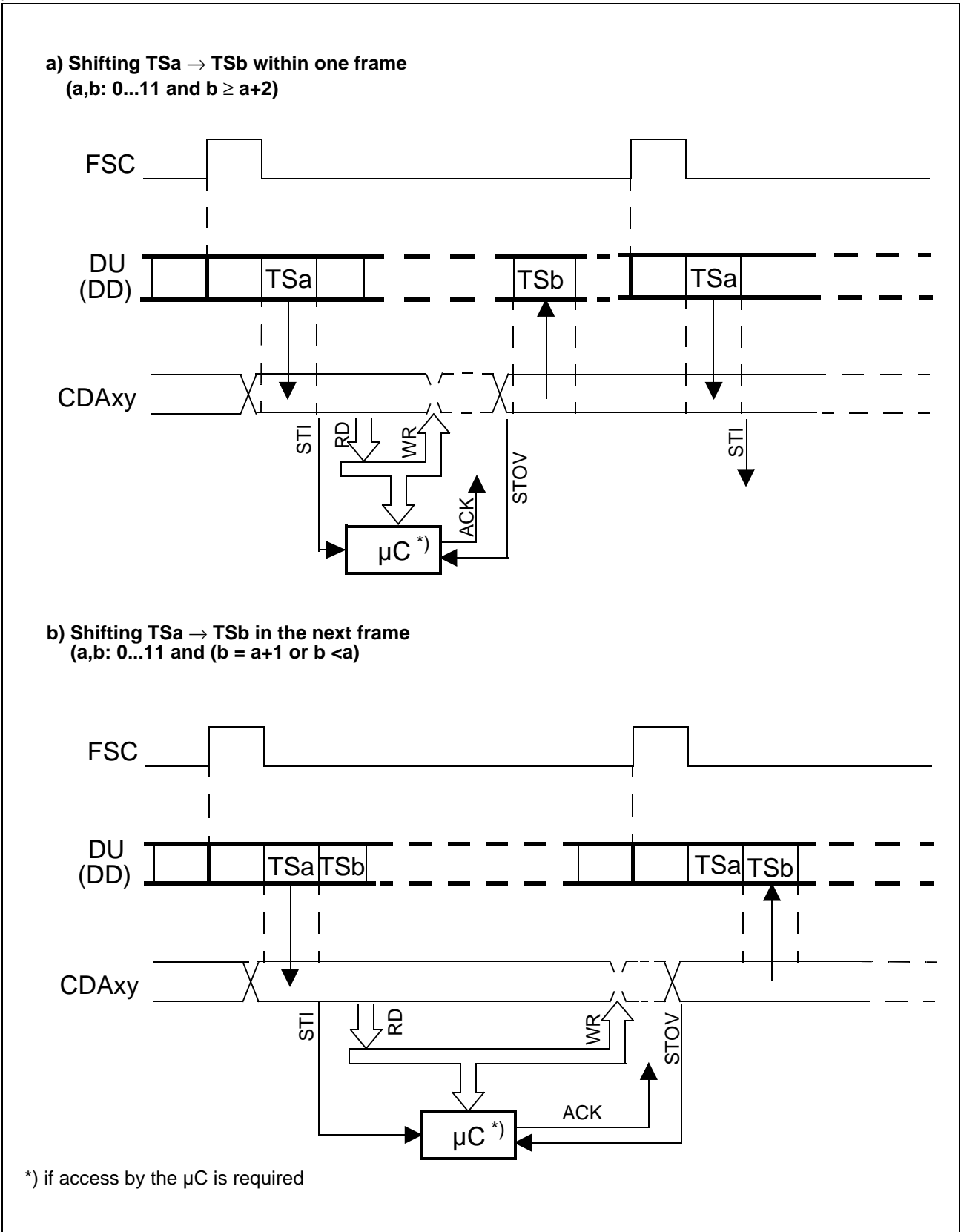

Figure 15 Data Access when Shifting TSa to TSb on DU (DD)

Functional Description

Monitoring Data

Figure 16 gives an example for monitoring of two IOM[®]-2 time slots each on DU or DD simultaneously. For monitoring on DU and/or DD the channel registers with even numbers (CDA10, CDA20) are assigned to time slots with even numbers TS(2n) and the channel registers with odd numbers (CDA11, CDA21) are assigned to time slots with odd numbers TS(2n+1). The user has to take care of this restriction by programming the appropriate time slots.

This mode is only valid if two blocks (e.g. both transceivers) are programmed to these timeslots and communicating via IOM[®]-2.

However, if only one block is programmed to this timeslot the timeslots for CDAx0 and CDAx1 can be programmed completely independently.

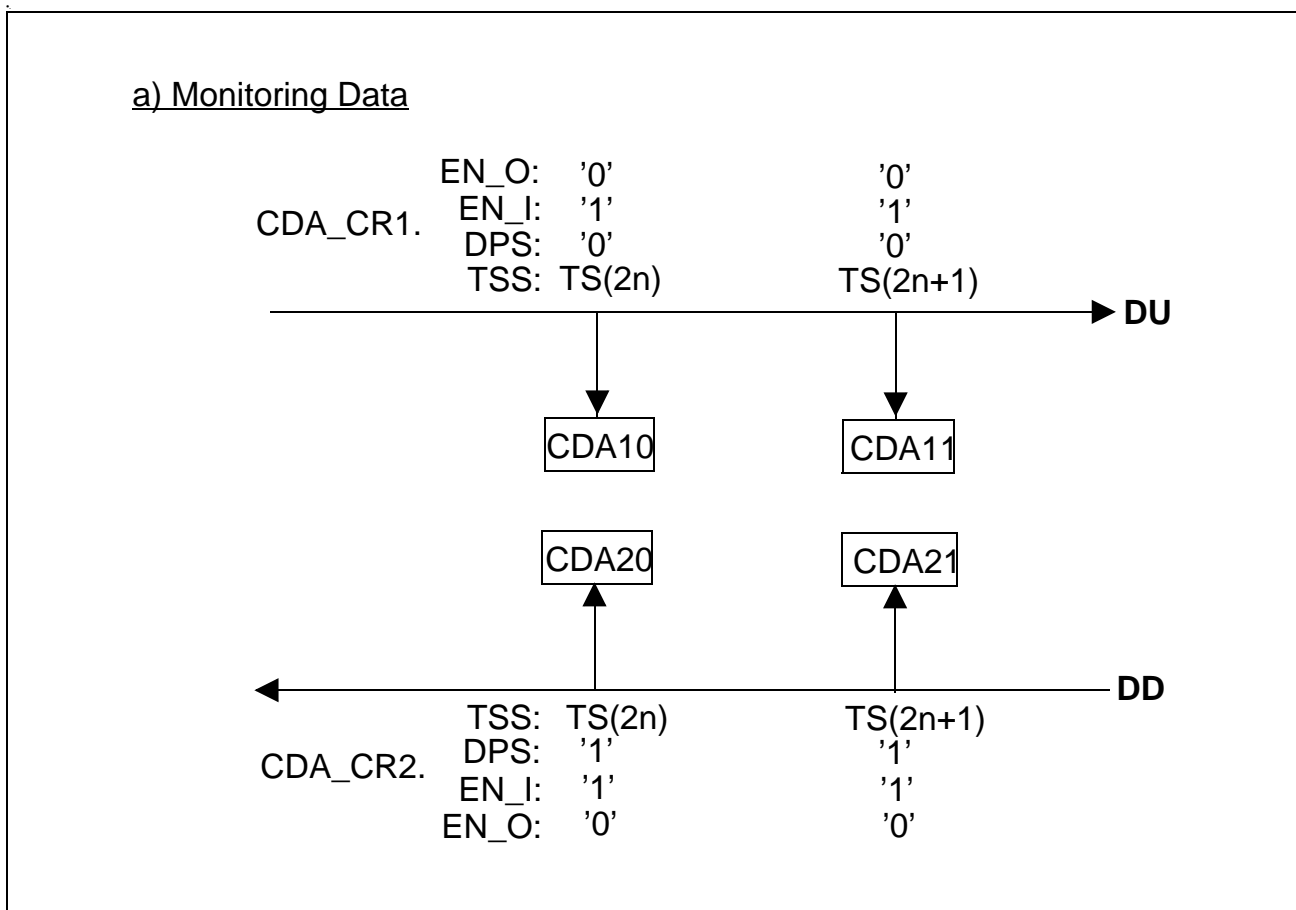

Figure 16 Example for Monitoring Data

Functional Description

Monitoring TIC Bus

Monitoring the TIC bus (TS11) is handled as a special case. The TIC bus can be monitored with the registers CDAX0 by setting the EN_TBM (Enable TIC Bus Monitoring) bit in the control registers CRx. The TSDPx0 must be set to 08_h for monitoring from DU or 88_h for monitoring from DD. By this it is possible to monitor the TIC bus (TS11) and the odd numbered D-channel (TS3) simultaneously on DU and DD.

Synchronous Transfer

While looping, shifting and switching the data can be accessed by the controller between the synchronous transfer interrupt (STI) and the synchronous transfer overflow interrupt (STOV).

The microcontroller access to each of the CDAXy registers can be synchronized by means of four programmable synchronous transfer interrupts (STIxy)¹⁾ and synchronous transfer overflow interrupts (STOVxy)²⁾ in the STI register.

Depending on the DPS bit in the corresponding TSDPxxy register the STIxy is generated two (for DPS='0') or one (for DPS='1') BCL clock after the selected time slot (CDA_TSDPxxy.TSS). One BCL clock is equivalent to two DCL clocks.

In the following description the index xy₀ and xy₁ are used to refer to two different interrupt pairs (STI/STOV) out of the four CDA interrupt pairs (STI10/STOV10, STI11/STOV11, STI20/STOV20, STI21/STOV21).

A STOVxy₀ is related to its STIxy₀ and is only generated if STIxy₀ is enabled and not acknowledged. However, if STIxy₀ is masked, the STOVxy₀ is generated for any other STIxy₁ which is enabled and not acknowledged.

Table 9 gives some examples for that. It is assumed that a STOV interrupt is only generated because a STI interrupt was not acknowledged before.

In example 1 only the STIxy₀ is enabled and thus STIxy₀ is only generated. If no STI is enabled, no interrupt will be generated even if STOV is enabled (example 2).

In example 3 STIxy₀ is enabled and generated and the corresponding STOVxy₀ is disabled. STIxy₁ is disabled but its STOVxy₁ is enabled, and therefore STOVxy₁ is generated due to STIxy₀. In example 4 additionally the corresponding STOVxy₀ is enabled, so STOVxy₀ and STOVxy₁ are both generated due to STIxy₀.

In example 5 additionally the STIxy₁ is enabled with the result that STOVxy₀ is only generated due to STIxy₀ and STOVxy₁ is only generated due to STIxy₁.

Compared to the previous example STOVxy₀ is disabled in example 6, so STOVxy₀ is not generated and STOVxy₁ is only generated for STIxy₁ but not for STIxy₀.

¹⁾ In order to enable the STI interrupts the input of the corresponding CDA register has to be enabled. This is also valid if only a synchronous write access is wanted. The enabling of the output alone does not effect an STI interrupt.

²⁾ In order to enable the STOV interrupts the output of the corresponding CDA register has to be enabled. This is also valid if only a synchronous read access is wanted. The enabling of the input alone does not effect an interrupt.

Functional Description

Table 9 Examples for Synchronous Transfer Interrupts

Enabled Interrupts (Register MSTI)		Generated Interrupts (Register STI)		
STI	STOV	STI	STOV	
xy ₀	-	xy ₀	-	Example 1
-	xy ₀	-	-	Example 2
xy ₀	xy ₁	xy ₀	xy ₁	Example 3
xy ₀	xy ₀ ; xy ₁	xy ₀	xy ₀ ; xy ₁	Example 4
xy ₀ ; xy ₁	xy ₀ ; xy ₁	xy ₀ xy ₁	xy ₀ xy ₁	Example 5
xy ₀ ; xy ₁	xy ₁	xy ₀ xy ₁	- xy ₁	Example 6
xy ₀ ; xy ₁	xy ₀ ; xy ₁ ; xy ₂	xy ₀ xy ₁	xy ₀ ; xy ₂ xy ₁ ; xy ₂	Example 7

Compared to example 5 in example 7 a third STOV_{xy₂} is enabled and thus STOV_{xy₂} is generated additionally for both STI_{xy₀} and STI_{xy₁}.

A STOV interrupt is not generated if all stimulating STI interrupts are acknowledged.

A STI_{xy} must be acknowledged by setting the ACK_{xy} bit in the ASTI register two BCL clock (for DPS='0') or one BCL clocks (for DPS='1') before the time slot which is selected for the appropriate STI_{xy}. The interrupt structure of the synchronous transfer is shown in [Figure 17](#).

Functional Description

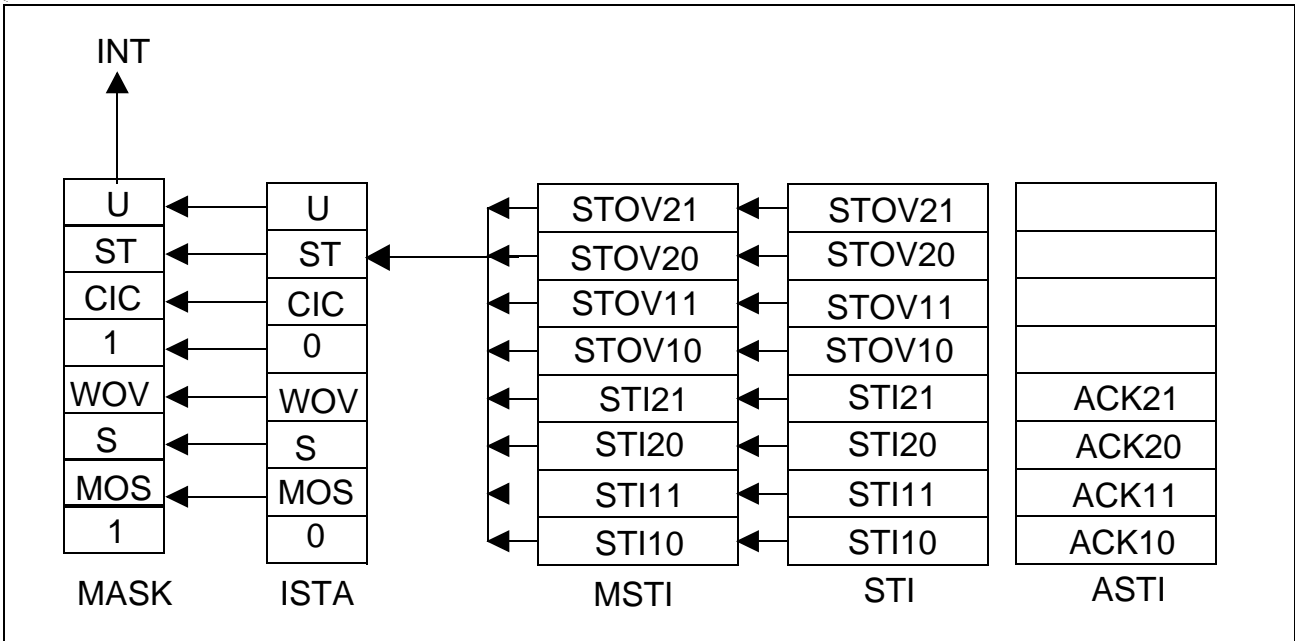

Figure 17 Interrupt Structure of the Synchronous Data Transfer

Figure 18 shows some examples based on the timeslot structure. Figure a) shows at which point in time a STI and STOV interrupt is generated for a specific timeslot. Figure b) is identical to example 3 above, figure c) corresponds to example 5 and figure d) shows example 4.

Functional Description

↓ : STI interrupt generated
 > : STOV interrupt generated for a not acknowledged STI interrupt

a) Interrupts for data access to time slot 0 (B1 after reset), MSTI.STI10 and MSTI.STOV10 enabled

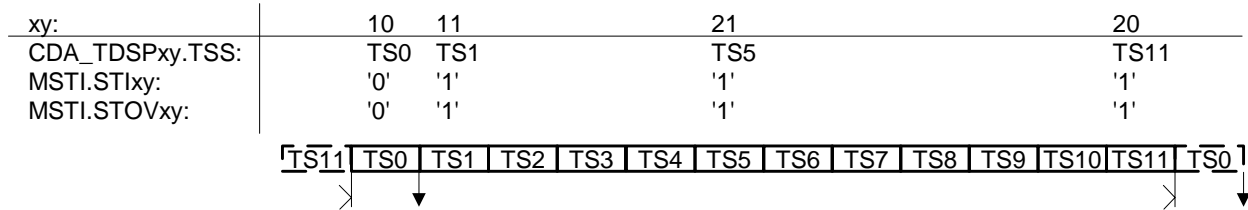

b) Interrupts for data access to time slot 0 (B1 after reset), STOV interrupt used as flag for "last possible CDA access"; MSTI.STI10 and MSTI.STOV20 enabled

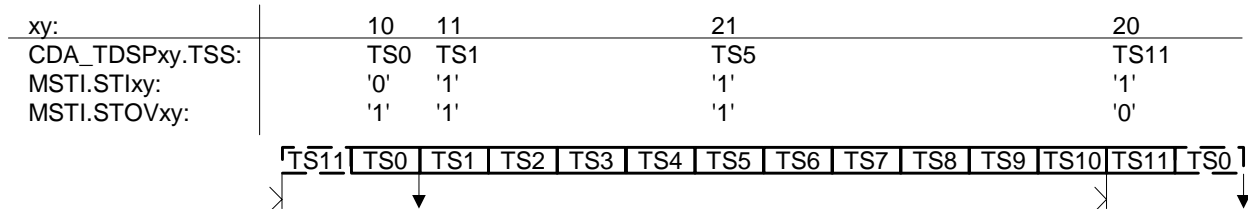

c) Interrupts for data access to time slot 0 and 1 (B1 and B2 after reset), MSTI.STI10, MSTI.STOV10, MSTI.STI11 and MSTI.STOV11 enabled

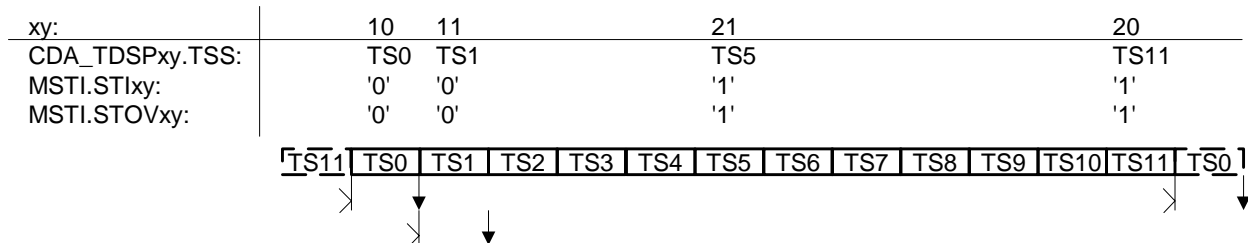

d) Interrupts for data access to time slot 0 (B1 after reset), STOV20 interrupt used as flag for "last possible CDA access", STOV10 interrupt used as flag for "CDA access failed"; MSTI.STI10, MSTI.STOV10 and MSTI.STOV20 enabled

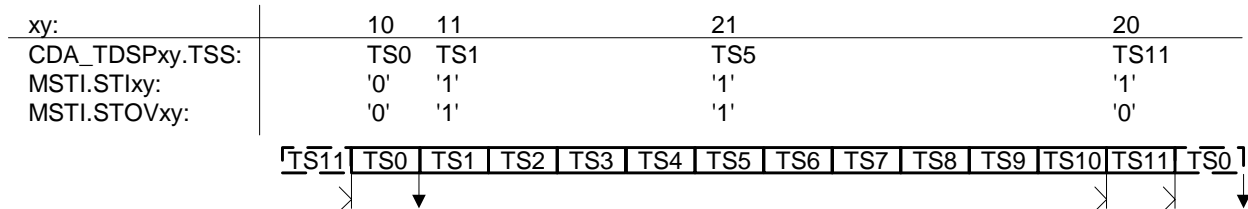

sti_stov.vsd

Figure 18 Examples for the Synchronous Transfer Interrupt Control with one STIxy enabled

Functional Description

2.3.2.2 Serial Data Strobe Signal

For time slot oriented standard devices at the IOM[®]-2 interface, the Q-SMINT[®]I provides two independent data strobe signals SDS1 and SDS2.

The two strobe signals can be generated with every 8-kHz-frame and are controlled by the registers SDS1/2_CR. By programming the TSS bits and three enable bits (ENS_TSS, ENS_TSS+1, ENS_TSS+3) a data strobe can be generated for the IOM[®]-2 time slots TS, TS+1 and TS+3 (bit7,6) and the combinations of them.

The data strobes for TS and TS+1 are always 8 bits long (bit7 to bit0) whereas the data strobe for TS+3 is always 2 bits long (bit7, bit6).

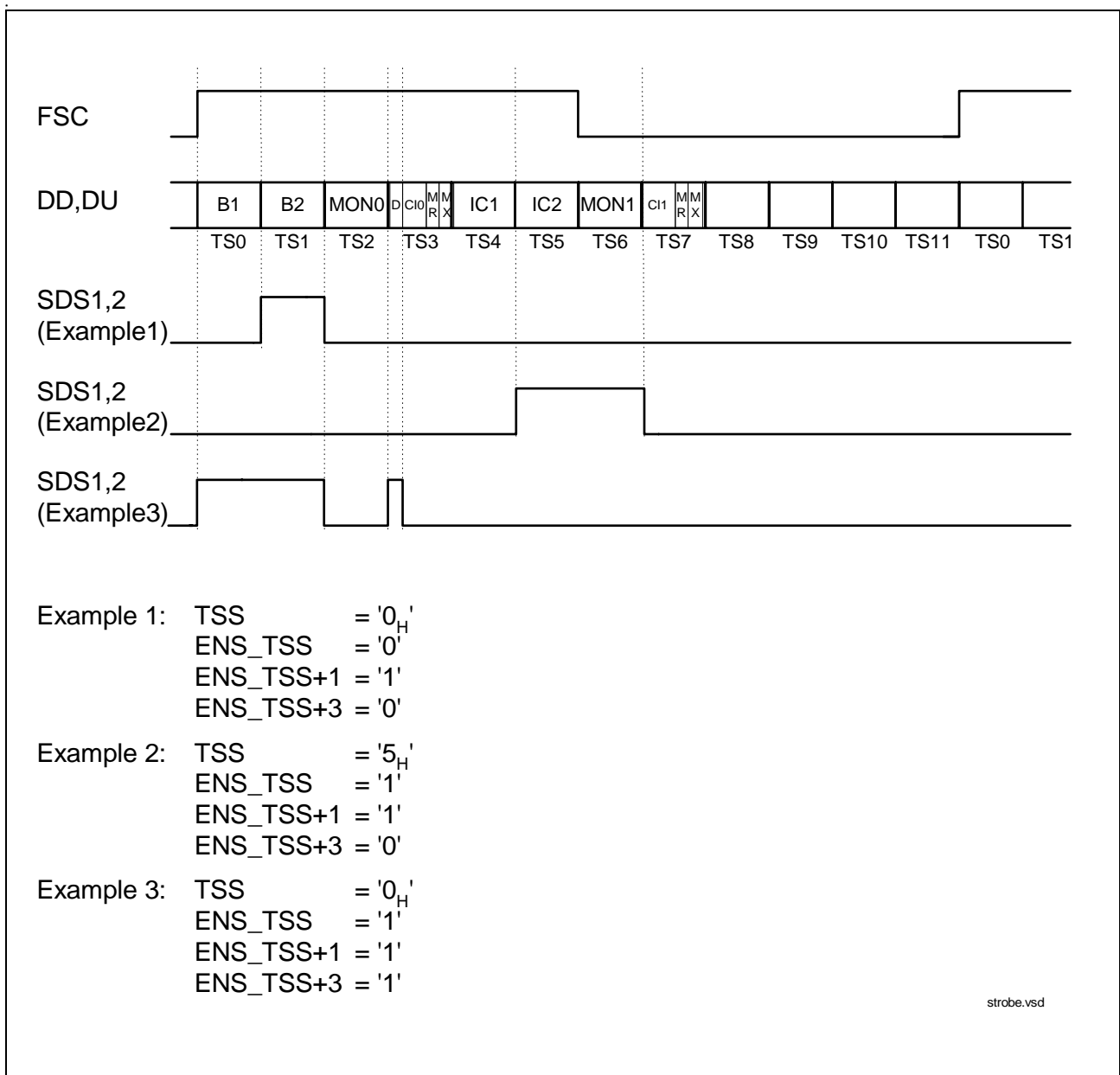

Figure 19 Data Strobe Signal Generation

Functional Description

Figure 19 shows three examples for the generation of a strobe signal. In example 1 the SDS is active during channel B2 on IOM[®]-2, whereas in the second example during IC2 and MON1. The third example shows a strobe signal for 2B+D channels which is used e.g. at an IDSL (144 kbit/s) transmission.

2.3.3 IOM[®]-2 Monitor Channel

The IOM[®]-2 MONITOR channel is utilized for information exchange between the Q-SMINT[®]I and other devices in the MONITOR channel.

The MONITOR channel data can be controlled by the bits in the MONITOR control register (MON_CR). For the transmission of the MONITOR data one of the 3 IOM[®]-2 channels can be selected by setting the MONITOR channel selection bits (MCS) in the MONITOR control register (MON_CR).

The DPS bit in the same register selects between an output on DU or DD respectively and with EN_MON the MONITOR data can be enabled/disabled. The default value is MONITOR channel 0 (MON0) enabled and transmission on DD.

The MONITOR channel of the Q-SMINT[®]I can be used in the following applications (refer also to **Figure 4** and **Figure 5**):

- As a **master device** the Q-SMINT[®]I can program and control other devices (e.g. PSB 2161) attached to the IOM[®]-2, which therefore, do not need a microcontroller interface.
- As a **slave device** the Q-SMINT[®]I is programmed and controlled from a master device on IOM[®]-2 (e.g. UTAH). This is used in applications where no microcontroller is connected directly to the Q-SMINT[®]I.

The MONITOR channel operates according to the IOM[®]-2 Reference Guide [13].

*Note: In contrast to the INTC-Q, the Q-SMINT[®]I does neither issue nor react on Monitor commands (MON0,1,2,8). Instead, the Q-SMINT[®]I operated in IOM[®]-2 slave mode must be programmed via new MONITOR channel concept (see **Chapter 2.3.3.4**), which provides full register access. The Monitor time out procedure is available. Reporting of the Q-SMINT[®]I is performed via interrupts.*

2.3.3.1 Handshake Procedure

The MONITOR channel operates on an asynchronous basis. While data transfers on the bus take place synchronized to frame sync, the flow of data is controlled by a handshake procedure using the MONITOR Channel Receive (MR) and MONITOR Channel Transmit (MX) bits. Data is placed onto the MONITOR channel and the MX bit is activated. This data will be transmitted once per 8-kHz frame until the transfer is acknowledged via the MR bit.

Functional Description

The MONITOR channel protocol is described In the following section and **Figure 22** shall illustrate this. The relevant control and status bits for transmission and reception are listed in **Table 10** and **Table 11**.

Table 10 Transmit Direction

Control/ Status Bit	Register	Bit	Function
Control	MOCR	MXC	MX Bit Control
		MIE	Transmit Interrupt (MDA, MAB, MER) Enable
Status	MOSR	MDA	Data Acknowledged
		MAB	Data Abort
	MSTA	MAC	Transmission Active

Table 11 Receive Direction

Control/ Status Bit	Register	Bit	Function
Control	MOCR	MRC	MR Bit Control
		MRE	Receive Interrupt (MDR) Enable
Status	MOSR	MDR	Data Received
		MER	End of Reception

Functional Description

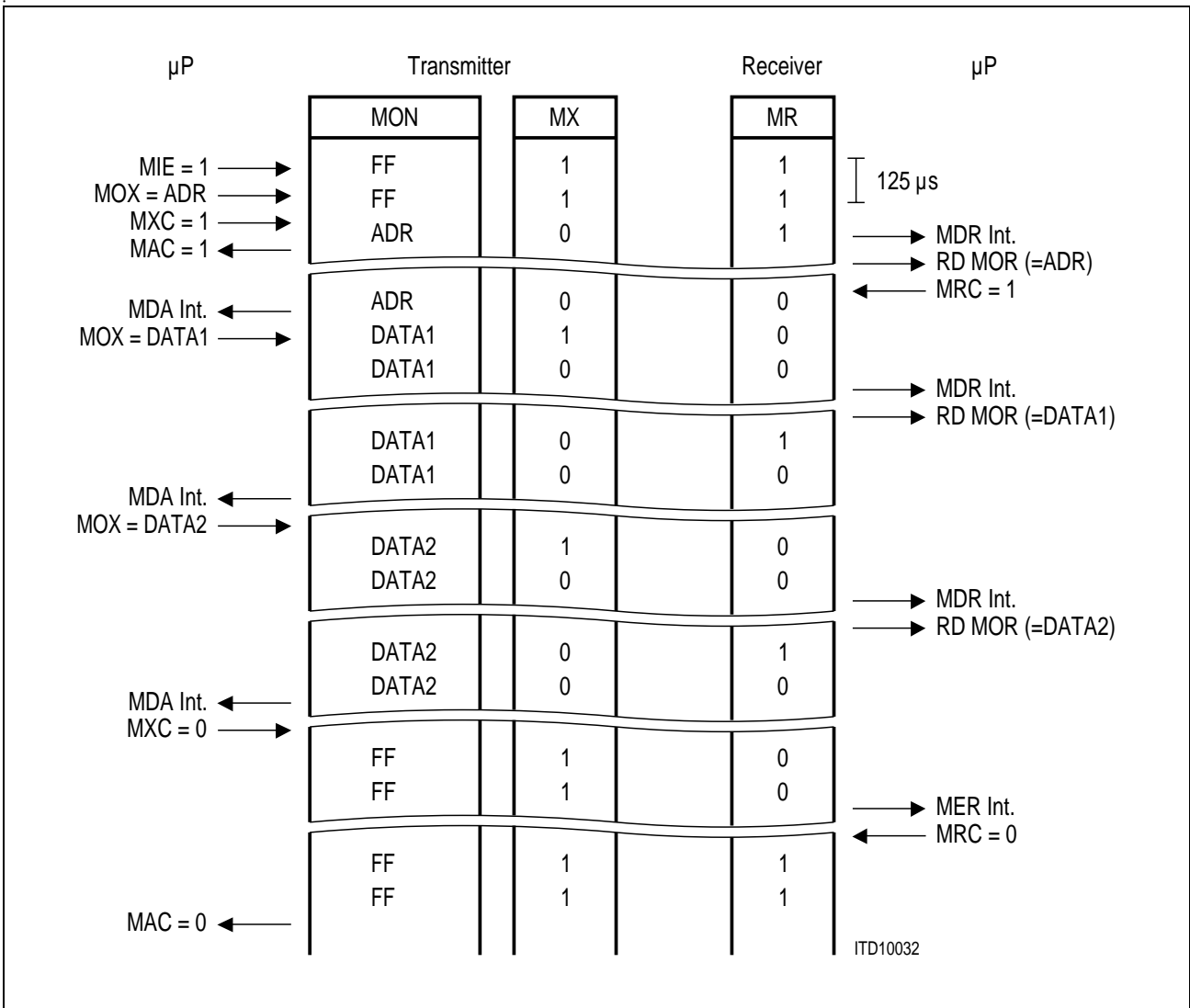

Figure 20 MONITOR Channel Protocol (IOM[®]-2)

Before starting a transmission, the microprocessor should verify that the transmitter is inactive, i.e. that a possible previous transmission has been terminated. This is indicated by a '0' in the MONITOR Channel Active MAC status bit.

After having written the MONITOR Data Transmit (MOX) register, the microprocessor sets the MONITOR Transmit Control bit MXC to '1'. This enables the MX bit to go active (0), indicating the presence of valid MONITOR data (contents of MOX) in the corresponding frame. As a result, the receiving device stores the MONITOR byte in its MONITOR Receive MOR register and generates a MDR interrupt status.

Alerted by the MDR interrupt, the microprocessor reads the MONITOR Receive (MOR) register. When it is ready to accept data (e.g. based on the value in MOR, which in a point-to-multipoint application might be the address of the destination device), it sets the MR control bit MRC to '1' to enable the receiver to store succeeding MONITOR channel bytes and acknowledge them according to the MONITOR channel protocol.

Functional Description

In addition, it enables other MONITOR channel interrupts by setting MONITOR Interrupt Enable (MIE) to '1'.

As a result, the first MONITOR byte is acknowledged by the receiving device setting the MR bit to '0'. This causes a MONITOR Data Acknowledge MDA interrupt status at the transmitter.

A new MONITOR data byte can now be written by the microprocessor in MOX. The MX bit is still in the active (0) state. The transmitter indicates a new byte in the MONITOR channel by returning the MX bit active after sending it once in the inactive state. As a result, the receiver stores the MONITOR byte in MOR and generates a new MDR interrupt status. When the microprocessor has read the MOR register, the receiver acknowledges the data by returning the MR bit active after sending it once in the inactive state. This in turn causes the transmitter to generate a MDA interrupt status.

This "MDA interrupt – write data – MDR interrupt – read data – MDA interrupt" handshake is repeated as long as the transmitter has data to send. Note that the MONITOR channel protocol imposes no maximum reaction times to the microprocessor.

When the last byte has been acknowledged by the receiver (MDA interrupt status), the microprocessor sets the MONITOR Transmit Control bit MXC to '0'. This enforces an inactive ('1') state in the MX bit. Two frames of MX inactive signifies the end of a message. Thus, a MONITOR Channel End of Reception MER interrupt status is generated by the receiver when the MX bit is received in the inactive state in two consecutive frames. As a result, the microprocessor sets the MR control bit MRC to 0, which in turn enforces an inactive state in the MR bit. This marks the end of the transmission, making the MONITOR Channel Active MAC bit return to '0'.

During a transmission process, it is possible for the receiver to ask a transmission to be aborted by sending an inactive MR bit value in two consecutive frames. This is effected by the microprocessor writing the MR control bit MRC to '0'. An aborted transmission is indicated by a MONITOR Channel Data Abort MAB interrupt status at the transmitter.

The MONITOR transfer protocol rules are summarized in the following section

- A pair of MX and MR in the inactive state for two or more consecutive frames indicates an **idle state** or an **end of transmission**.
- A **start of a transmission** is initiated by the transmitter by setting the MXC bit to '1' enabling the internal MX control. The receiver acknowledges the received first byte by setting the MR control bit to '1' enabling the internal MR control.
- The internal MX, MR control indicates or acknowledges a new byte in the MON slot by toggling MX, MR from the active to the inactive state for one frame.
- Two frames with the MR-bit set to inactive indicate a receiver request for **abort**.
- The transmitter can **delay a transmission** sequence by sending the same byte continuously. In that case the MX-bit remains active in the IOM[®]-2 frame following the first byte occurrence. Delaying a transmission sequence is only possible while the receiver MR-bit and the transmitter MX-bit are active.

Functional Description

- Since a **double last-look criterion** is implemented the receiver is able to receive the MON slot data at least twice (in two consecutive frames), the receiver waits for the acknowledge of the reception of two identical bytes in two successive frames.
- To control this handshake procedure a collision detection mechanism is implemented in the transmitter. This is done by making a **collision check** per bit on the transmitted MONITOR data and the MX bit.
- Monitor data will be transmitted repeatedly until its reception is acknowledged or the transmission time-out timer expires.
- Two frames with the MX bit in the inactive state indicates the **end of a message** (EOM).
- Transmission and reception of monitor messages can be performed simultaneously. This feature is used by the device to send back the response before the transmission from the controller is completed (the device does not wait for EOM from controller).

2.3.3.2 Error Treatment

In case the device does not detect identical monitor messages in two successive frames, transmission is not aborted. Instead the device will wait until two identical bytes are received in succession.

A transmission is aborted by the device if

- an error in the MR handshaking occurs
- a collision on the IOM[®]-2 bus of the MONITOR data or MX bit occurs
- the transmission time-out timer expires

A reception is aborted by the device if

- an error in the MX handshaking occurs or
- an abort request from the opposite device occurs

MX/MR Treatment in Error Case

In the master mode the MX/MR bits are under control of the microcontroller through MXC or MRC, respectively. An abort is indicated by an MAB interrupt or MER interrupt, respectively.

In the slave mode the MX/MR bits are under control of the device. An abort is always indicated by setting the MX/MR bit inactive for two or more IOM[®]-2 frames. The controller must react with EOM.

Figure 21 shows an example for an abort requested by the receiver, **Figure 22** shows an example for an abort requested by the transmitter and **Figure 23** shows an example for a successful transmission.

Functional Description

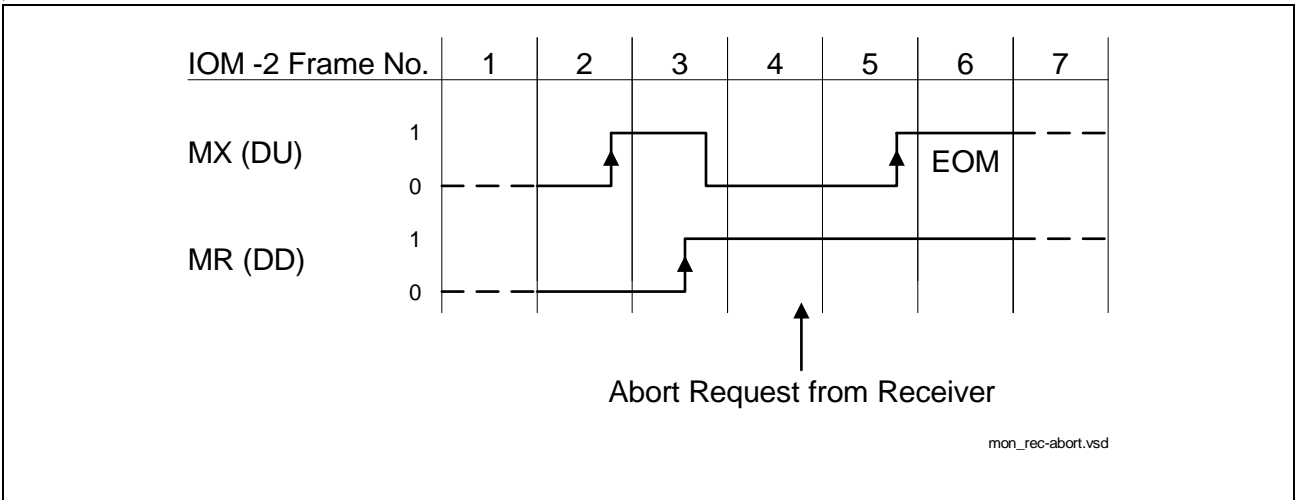

Figure 21 Monitor Channel, Transmission Abort requested by the Receiver

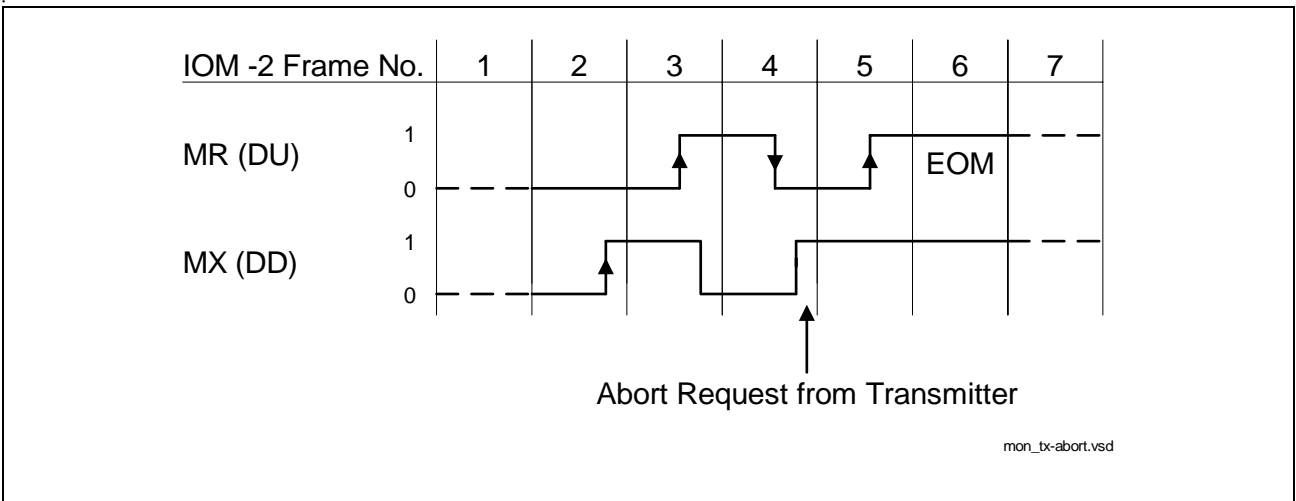

Figure 22 Monitor Channel, Transmission Abort requested by the Transmitter

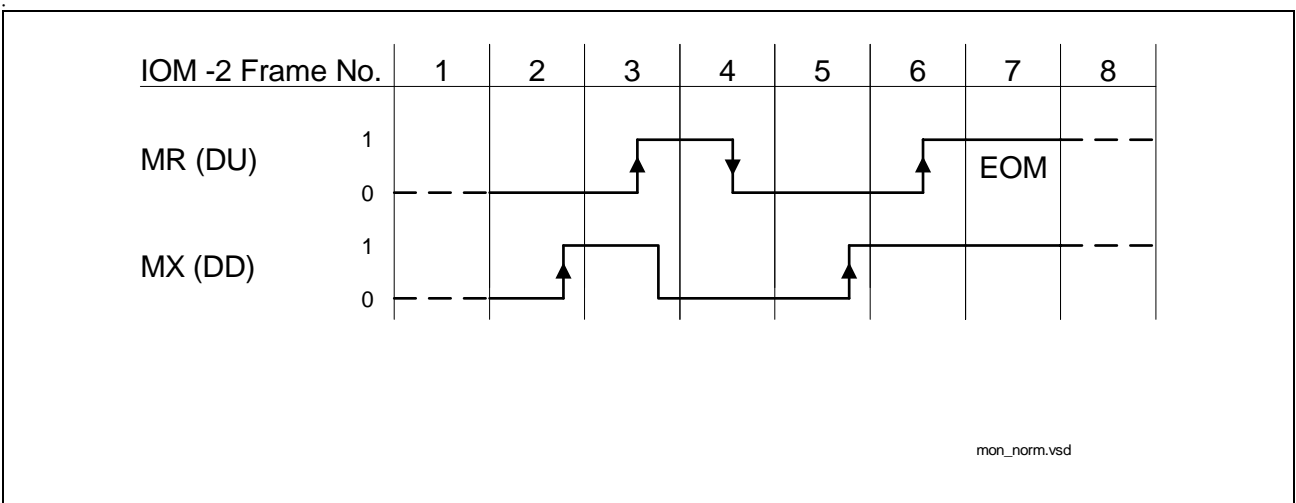

Figure 23 Monitor Channel, Normal End of Transmission

Functional Description

2.3.3.3 MONITOR Channel Programming as a Master Device

The master mode is selected by default if one of the microcontroller interfaces is selected. The monitor data is written by the microcontroller in the MOX register and transmitted via IOM[®]-2 DD(DU) line to the programmed/controlled device e.g. ARCOFI-BA PSB 2161. The transfer of the commands in the MON channel is regulated by the handshake protocol mechanism with MX, MR.

2.3.3.4 MONITOR Channel Programming as a Slave Device

MONITOR slave mode can be selected by pinstrapping the microcontroller interface pins according to [Table 4](#). All programming data required by the device is received in the MONITOR time slot on the IOM[®]-2 and is transferred to the MOR register. The transfer of the commands in the MON channel is regulated by the handshake protocol mechanism with MX, MR which is described in the previous [Chapter 2.3.3.1](#).

The first byte of the MONITOR message must contain in the higher nibble the MONITOR channel address code which is '1000' for the Q-SMINT[®]I. The lower nibble distinguishes between a programming command and an identification command.

Identification Command

In order to be able to identify unambiguously different hardware designs of the Q-SMINT[®]I by software, the following identification command is used:

DU 1st byte value	1	0	0	0	0	0	0	0	0
DU 2nd byte value	0	0	0	0	0	0	0	0	0

The Q-SMINT[®]I responds to this identification sequence by sending a identification sequence:

DD 1st byte value	1	0	0	0	0	0	0	0	0
DD 2nd byte value	0	0	DESIGN				<IDENT>		

DESIGN: six bit code, specific for each device in order to identify differences in operation (see [“ID - Identification Register” on Page 164](#)).

This identification sequence is usually done once, when the Q-SMINT[®]I is connected for the first time. This function is used so that the software can distinguish between different possible hardware configurations. However this sequence is not compulsory.

Programming Sequence

The programming sequence is characterized by a '1' being sent in the lower nibble of the received address code. **The data structure after this first byte is equivalent to the structure of the serial control interface described in chapter [Chapter 2.1.1](#).**

Functional Description

DU 1st byte value	1	0	0	0	0	0	0	1
DU 2nd byte value	Header Byte							
DU 3rd byte value	R/W	Command/ Register Address						
DU 4th byte value	Data 1							
DU (nth + 3) byte value	Data n							

All registers can be read back when setting the R/W bit to '1'. The Q-SMINT[®]I responds by sending his IOM[®]-2 specific address byte (81_H) followed by the requested data.

Note: Application Hint:

It is not allowed to disable the MX- and MR-control in the programming device at the same time! First, the MX-control must be disabled, then the μC has to wait for an End of Reception before the MR-control may be disabled. Otherwise, the Q-SMINT[®]I does not recognize an End of Reception.

2.3.3.5 Monitor Time-Out Procedure

To prevent lock-up situations in a MONITOR transmission a time-out procedure can be enabled by setting the time-out bit (TOUT) in the MONITOR configuration register (MCONF). An internal timer is always started when the transmitter must wait for the reply of the addressed device or for transmit data from the microcontroller. After 40 IOM[®]-2 frames (5 ms) without reply the timer expires and the transmission will be aborted with an EOM (End of Message) command by setting the MX bit to '1' for two consecutive IOM[®]-2 frames.

2.3.3.6 MONITOR Interrupt Logic

Figure 24 shows the interrupt structure of the MONITOR handler. The MONITOR Data Receive interrupt status MDR has two enable bits, MONITOR Receive interrupt Enable (MRE) and MR bit Control (MRC). The MONITOR channel End of Reception MER, MONITOR channel Data Acknowledged MDA and MONITOR channel Data Abort MAB interrupt status bits have a common enable bit MONITOR Interrupt Enable MIE.

MRE set to "0" prevents the occurrence of MDR status, including when the first byte of a packet is received. When MRE is set to "1" but MRC is set to "0", the MDR interrupt status is generated only for the first byte of a receive packet. When both MRE and MRC are set to "1", MDR is always generated and all received MONITOR bytes - marked by a 1-to-0 transition in MX bit - are stored. Additionally, a MRC set to "1" enables the control of the MR handshake bit according to the MONITOR channel protocol.

Functional Description

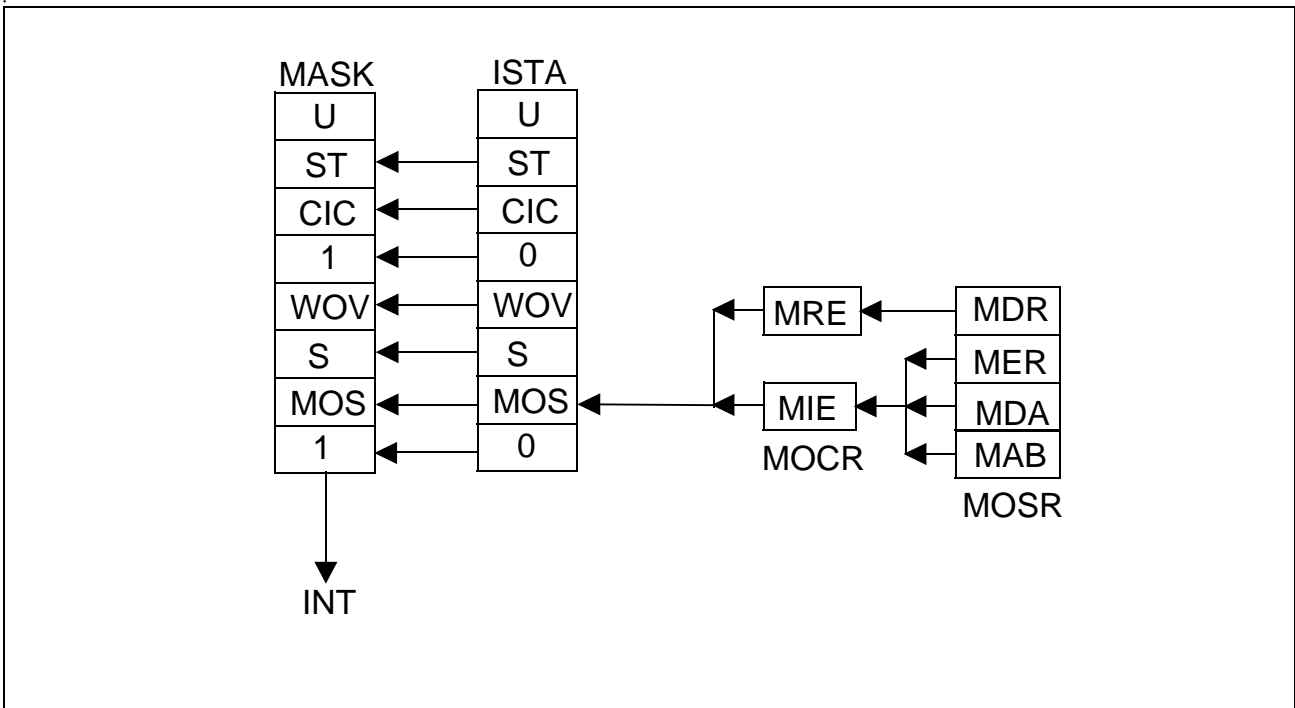

Figure 24 MONITOR Interrupt Structure

2.3.4 C/I Channel Handling

The Command/Indication channel carries real-time status information between the Q-SMINT[®]I and another device connected to the IOM[®]-2.

1) C/I0 channel lies in IOM[®]-2 channel 0 and access may be arbitrated via the TIC bus access protocol. In this case the arbitration is done in IOM[®]-2 channel 2.

The C/I0 channel is accessed via register CIR0 (received C/I0 data from DD) and register CIX0 (transmitted C/I0 data to DU). The C/I0 code is four bits long.

In the receive direction, the code from layer-1 is continuously monitored, with an interrupt being generated any time a change occurs (ISTA.CIC).

C/I0 only: a new code must be found in two consecutive IOM[®]-2 frames to be considered valid and to trigger a C/I code change interrupt status (double last look criterion).

In the transmit direction, the code written in CIX0 is continuously transmitted in C/I0.

2) A second C/I channel (called C/I1) lies in IOM[®]-2 channel 1 and is used to convey real time status information of the on-chip S-transceiver or an external device. The C/I1 channel consists of four or six bits in each direction. The width can be changed from 4 bit to 6 bit by setting bit CIX1.CICW.

Functional Description

In 4-bit mode 6-bits are written whereby the higher 2 bits must be set to “1” and 6-bits are read whereby only the 4 LSBs are used for comparison and interrupt generation (i.e. the higher two bits are ignored).

The C/I1 channel is accessed via registers CIR1 and CIX1. The connection of CIR1 and CIX1 to DD and DU, respectively, can be selected by setting bit CI_CR.DPS_CI1. A change in the received C/I1 code is indicated by an interrupt status without double last look criterion.

CIC Interrupt Logic

Figure 25 shows the CIC interrupt structure.

The two corresponding status bits CIC0 and CIC1 are read in CIR0 register. CIC1 can be individually disabled by clearing the enable bit CI1E in the CIX1 register. In this case the occurrence of a code change in CIR1 will not be displayed by CIC1 until the corresponding enable bit has been set to one.

Bits CIC0 and CIC1 are cleared by a read of CIR0.

An interrupt status is indicated every time a valid new code is loaded in CIR0 or CIR1. The CIR0 is buffered with a FIFO size of two. If a second code change occurs in the received C/I channel 0 before the first one has been read, immediately after reading of CIR0 a new interrupt will be generated and the new code will be stored in CIR0. If several consecutive codes are detected, only the first and the last code are obtained at the first and second register read, respectively.

For CIR1 no FIFO is available. The actual code of the received C/I channel 1 is always stored in CIR1.

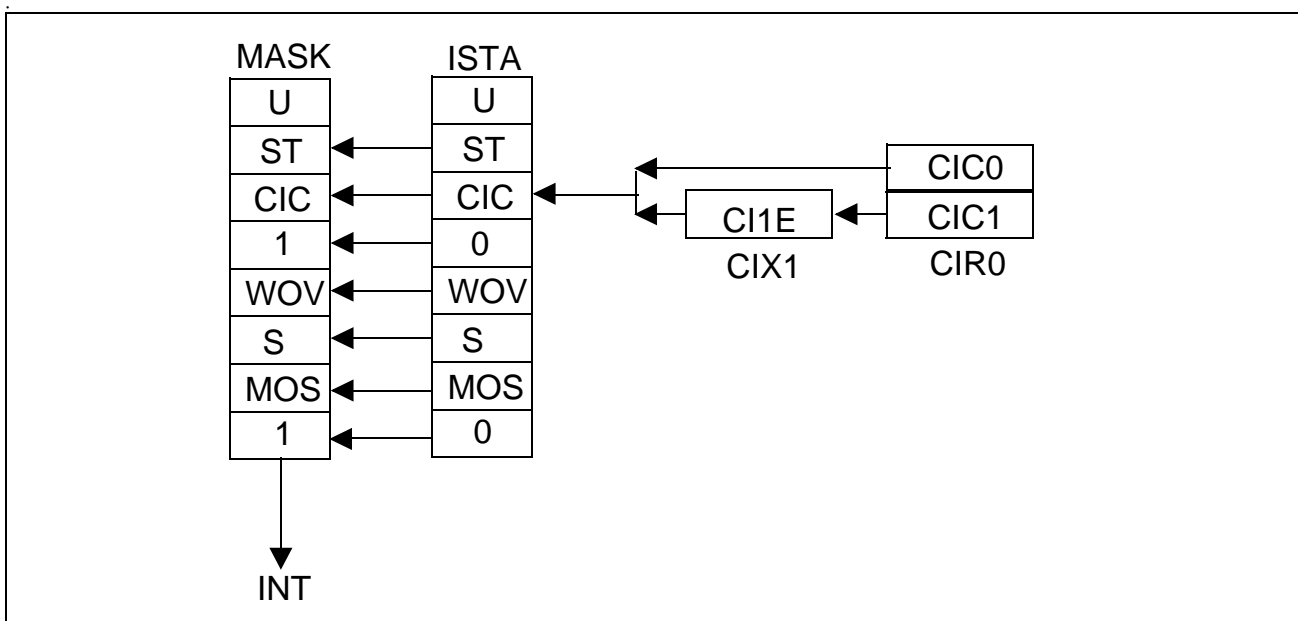

Figure 25 CIC Interrupt Structure

Functional Description

2.3.5 D-Channel Access Control

The upstream D-channel is arbitrated between the S-bus and external HDLC controllers via the TIC bus (S/G, BAC, TBA bits) according to the IOM[®]-2 Reference Guide¹⁾. Further to the implementation in the INTC-Q it is possible, to set the priority (8 or 10) of all HDLC-controllers connected to IOM[®]-2, which is particularly useful for use of the Q-SMINT[®]I together with the UTAH.

2.3.5.1 Application Examples for D-Channel Access Control

Figure 26 and Figure 27 show different scenarios for the local D-channel arbitration between the S-bus and the microcontroller.

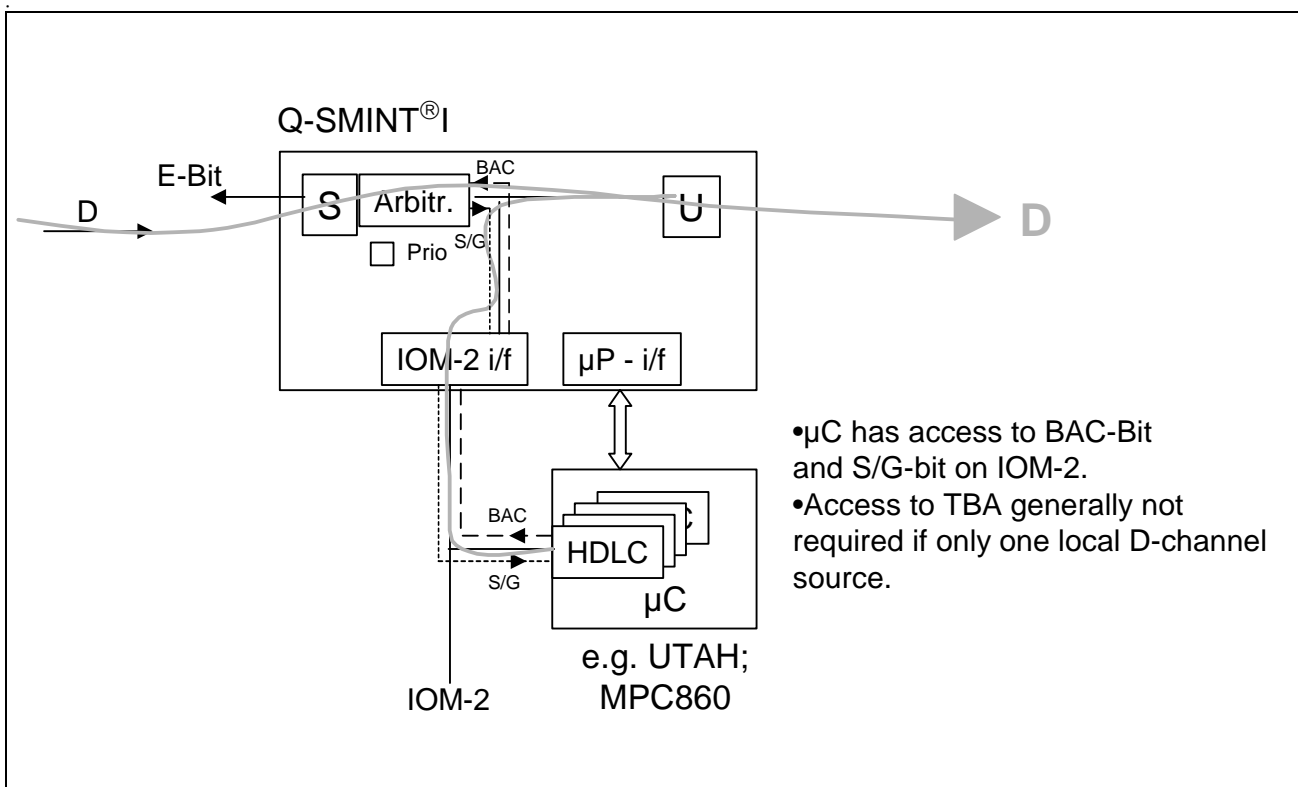

Figure 26 D-Channel Arbitration: μC with HDLC and Direct Access to TIC Bus

¹⁾ The A/B-bit is not supported by the U-transceiver

Functional Description

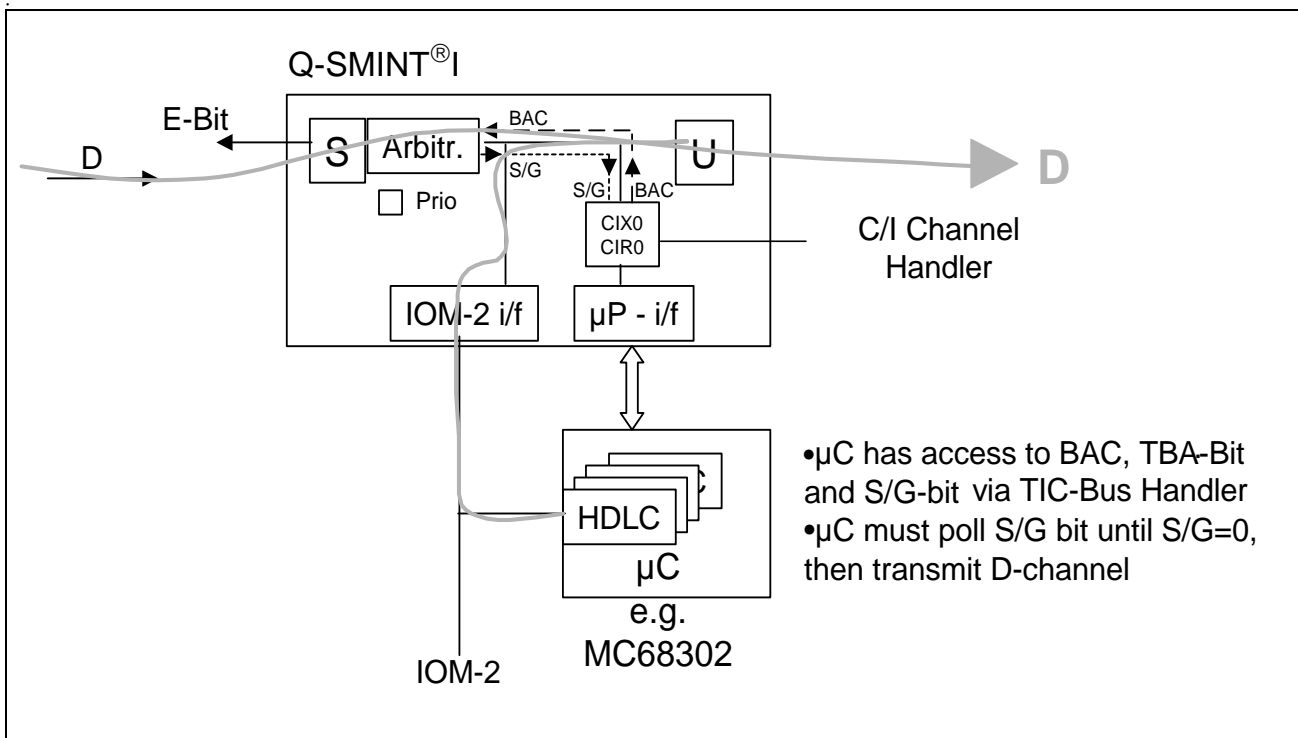

Figure 27 D-Channel Arbitration: μ C with HDLC and no Access to TIC Bus

2.3.5.2 TIC Bus Handling

The TIC bus is implemented to organize the access to the C/I0-channel and to the D-channel from up to 7 D-channels HDLC controllers. The arbitration mechanism must be activated by setting $MODEH.DIM2-0=00x$.

The arbitration mechanism is implemented in the last octet in IOM[®]-2 channel 2 of the IOM[®]-2 interface (see [Figure 28](#)). An access request to the TIC bus may either be generated by software (μ C access to the C/I0-channel via CIX0 register) or by an external D-channel HDLC controller (transmission of an HDLC frame in the D-channel). A software access request to the bus is effected by setting the BAC bit in register CIX0 to '1' (resulting in BAC = '0' on IOM[®]-2).

In the case of an access request by the Q-SMINT[®]I, the Bus Accessed-bit BAC (bit 5 of last octet of CH2 on DU, see [Figure 28](#)) is checked for the status "bus free", which is indicated by a logical '1'. If the bus is free, the Q-SMINT[®]I transmits its individual TIC bus address TAD programmed in the CIX0 register (CIX0.TBA2-0). While being transmitted the TIC bus address TAD is compared bit by bit with the value read back on DU. If a sent bit set to '1' is read back as '0' because of the access of an external device with a lower TAD, the Q-SMINT[®]I withdraws immediately from the TIC bus, i.e. the remaining TAD bits are not transmitted. The TIC bus is occupied by the device which sends and reads back its address error-free. If more than one device attempt to seize the bus simultaneously, the one with the lowest address values wins. This one will set BAC=0 on TIC bus and starts D-channel transmission in the same frame.

Functional Description

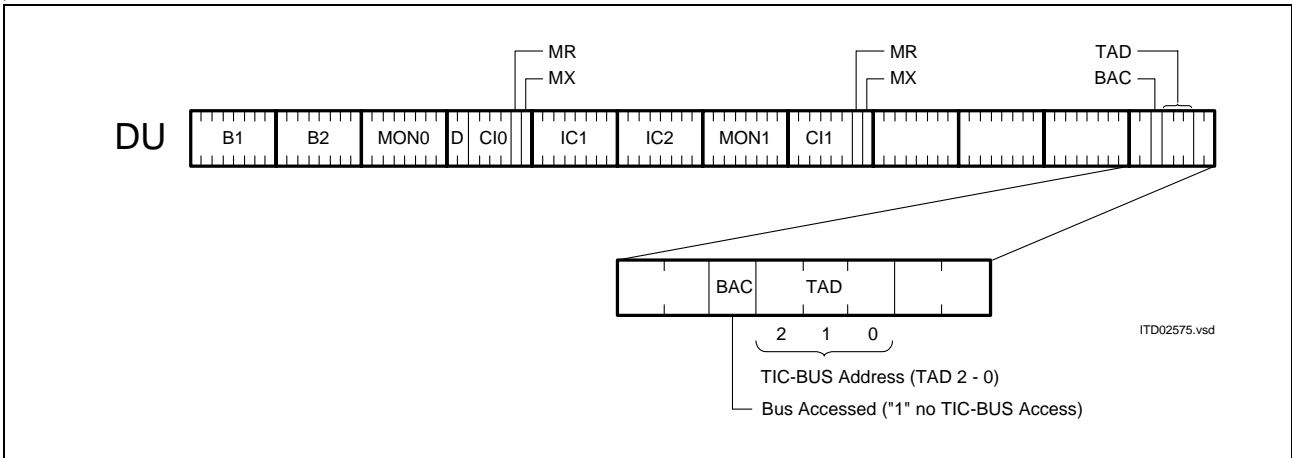

Figure 28 Structure of Last Octet of Ch2 on DU

When the TIC bus is seized by the Q-SMINT[®]I, the bus is identified to other devices as occupied via the DU Ch2 Bus Accessed-bit state '0' until the access request is withdrawn. After a successful bus access, the Q-SMINT[®]I is automatically set into a lower priority class, that is, a new bus access cannot be performed until the status "bus free" is indicated in two successive frames.

If none of the devices connected to the IOM[®]-2 interface request access to the D and C/I0 channels, the TIC bus address 7 will be present. The device with this address will therefore have access, by default, to the D and C/I0 channels.

Note: Bit BAC (CIX0 register) should be reset by the μ C when access is no more requested, to grant other devices access to the D and C/I0 channels.

2.3.5.3 Stop/Go Bit Handling

The availability of the DU D channel is indicated in bit 5 "Stop/Go" (S/G) of the last octet in DD channel 2 (Figure 29). The arbitration mechanism must be activated by setting MODEH.DIM2-0=0x1.

- S/G = 1 : stop
- S/G = 0 : go

The Stop/Go bit is available to other layer-2 devices connected to the IOM[®]-2 interface to determine if they can access the D channel in upstream direction.

Functional Description

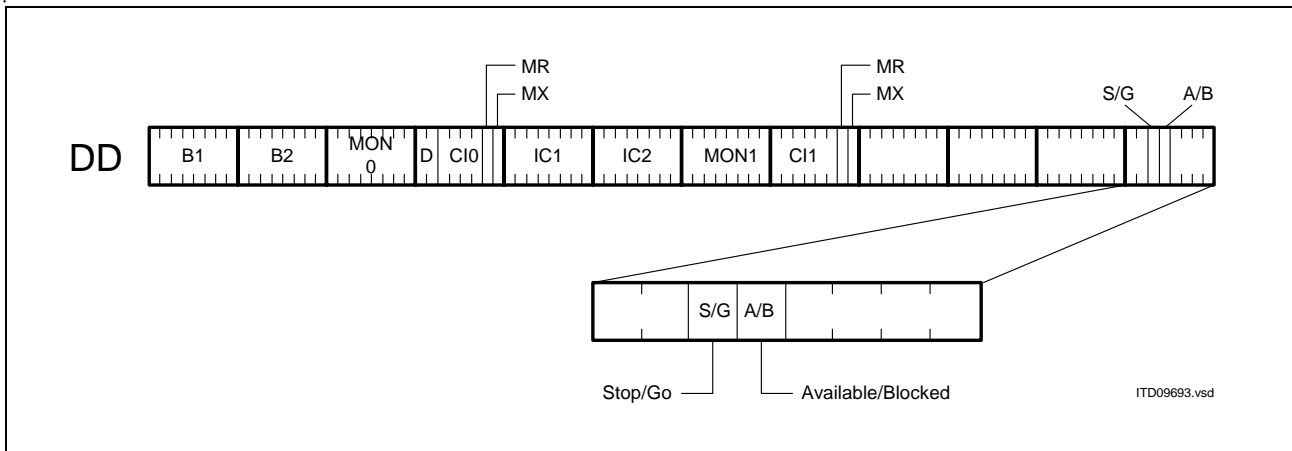

Figure 29 Structure of Last Octet of Ch2 on DD

2.3.5.4 D-Channel Arbitration

In intelligent NT applications (selected via register S_MODE.MODE2-0) the Q-SMINT[®]I has to share the upstream D-channel with one or more D-channel controllers on the IOM[®]-2 interface and with all connected TEs on the S interface.

The S-transceiver incorporates an elaborate state machine for D-channel priority handling on IOM[®]-2 ([Chapter 2.3.5.5](#)). For the access to the D-channel a similar arbitration mechanism as on the S interface (writing D-bits, reading back E-bits) is performed for all D-channel sources on IOM[®]-2. Due to this an equal and fair access is guaranteed for all D-channel sources on both the S interface and the IOM[®]-2 interface. The access to the upstream D-channel is handled via the S/G bit for the HDLC controllers and via E-bit for all connected terminals on S (E-bits are inverted to block the terminals on S). Furthermore, if more than one HDLC source is requesting D-channel access on IOM[®]-2 the TIC bus mechanism is used (see [Chapter 2.3.5.2](#)).

The arbiter permanently counts the “1s” in the upstream D-channel on IOM[®]-2. If the necessary number of “1s” is counted and an HDLC controller on IOM[®]-2 requests upstream D-channel access (BAC bit is set to 0), the arbiter allows this D-channel controller immediate access and blocks other TEs on S (E-bits are inverted). Similar as on the S-interface the priority for D-channel access on IOM[®]-2 can be configured to 8 or 10 (S_CMD.DPRIO).

The configuration settings of the Q-SMINT[®]I in intelligent NT applications are summarized in [Table 12](#).

Functional Description

Table 12 Q-SMINT[®]I Configuration Settings in Intelligent NT Applications

Functional Block	Configuration Description	Configuration Setting
Layer 1	Select Intelligent NT mode	S-Transceiver Mode Register: S_MODE.MODE0 = 0 (NT state machine) or S_MODE.MODE0 = 1 (LT-S state machine) S_MODE.MODE1 = 1 S_MODE.MODE2 = 1
Layer 2	Enable S/G bit and TIC bus evaluation	D-channel Mode Register: MODEH.DIM2-0 = 001

Note: For mode selection in the S_MODE register the MODE1/2 bits are used to select intelligent NT mode, MODE0 selects NT or LT-S state machine.

With the configuration settings shown above the Q-SMINT[®]I in intelligent NT applications provides for equal access to the D-channel for terminals connected to the S-interface and for D-channel sources on IOM[®]-2.

2.3.5.5 State Machine of the D-Channel Arbiter

Figure 30 gives a simplified view of the state machine of the D-channel arbiter. CNT is the number of '1' on the IOM[®]-2 D-channel and BAC corresponds to the BAC-bit on IOM[®]-2. The number n depends on configuration settings (selected priority 8 or 10) and the condition of the previous transmission, i.e. if an abort was seen (n = 8 or 10, respectively) or if the last transmission was successful (n = 9 or 11, respectively).

Functional Description

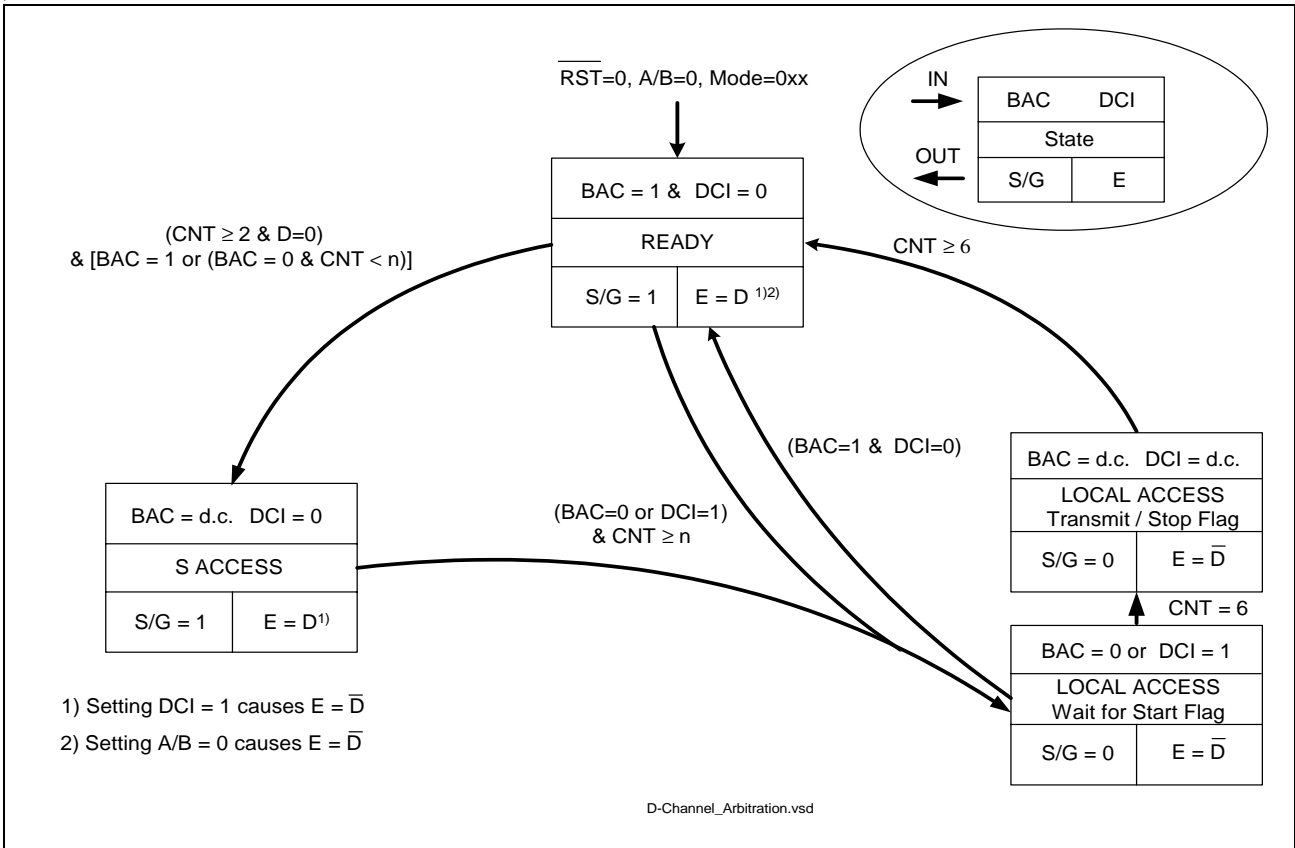

Figure 30 State Machine of the D-Channel Arbiter (Simplified View)¹⁾

Table 13 lists the major differences of the D-channel arbiter’s state machine between Q-SMINT[®]I and INTC-Q [12]

Table 13 Major Differences D-Channel Arbiter INTC-Q and Q-SMINT[®]I

	INTC-Q	Q-SMINT [®] I
State 'IDLE' (S/G=0, E=D)	Automatically entered from state 'READY' or 'S ACCESS' after CNT=n	Not available, initial state is 'READY' (S/G=1, E=D)
BAC-bit	Ignored	Local HDLC must tie BAC = '0' to enter state 'LOCAL ACCESS'
D-channel inhibit	Not possible	S-MODE.DCH_INH Alternative to BAC-bit to enter state 'LOCAL ACCESS'

¹⁾ If the S-transceiver is reset by SRES.RES_S = '1' or disabled by S_CONF0.DIS_TR = '1', then the D-channel arbiter is in state Ready (S/G = '1'), too. The S/G evaluation of the HDLC has to be disabled in this case; otherwise, the HDLC is not able to send data.

Functional Description

1. Local D-Channel Controller Transmits Upstream

In the initial state ('Ready' state) neither the local D-channel sources nor any of the terminals connected to the S-bus transmit in the D-channel.

The Q-SMINT[®]I S-transceiver thus receives BAC = "1" (IOM[®]-2 DU line) and transmits S/G = "1" (IOM[®]-2 DD line). The access will then be established according to the following procedure:

- Local D-channel source verifies that BAC bit is set to ONE (currently no bus access).
- Local D-channel source issues TIC bus address and verifies that no controller with higher priority requests transmission (TIC bus access must always be performed even if no other D-channel sources are connected to IOM[®]-2).
- Local D-channel source issues BAC = "0" to block other sources on IOM[®]-2 and to announce D-channel access.
- Q-SMINT[®]I S-transceiver pulls S/G bit to ZERO ('Local Access' state) as soon as $CNT \geq n$ (see note) to allow sending D-channel data from the entitled source. Q-SMINT[®]I S-transceiver transmits inverted echo channel (E bits) on the S-bus to block all connected S-bus terminals ($E = \bar{D}$).
- Local D-channel source commences with D data transmission on IOM[®]-2 as long as it receives S/G = "0".
- After D-channel data transmission is completed the controller sets the BAC bit to ONE.
- Q-SMINT[®]I S-transceiver transmits non-inverted echo ($E = D$).
- Q-SMINT[®]I S-transceiver pulls S/G bit to ONE ('Ready' state) to block the D-channel controller on IOM[®]-2.

Note: If right after D-data transmission the D-channel arbiter goes to state 'Ready' and the local D-channel source wants to transmit again, then it may happen that the leading '0' of the start flag is written into the D-channel before the D-channel source recognizes that the S/G bit is pulled to '1' and stops transmission. In order to prevent unintended transitions to state 'S-Access', the additional condition $CNT \geq 2$ is introduced. As soon as $CNT \geq n$, the S/G bit is set to '0' and the D-channel source may start transmission again (if TIC bus is occupied). This allows an equal access for D-channel sources on IOM[®]-2 and on the S interface.

2. Terminal Transmits D-Channel Data Upstream

The initial state is identical to that described in the last paragraph. When one of the connected S-bus terminals needs to transmit in the D-channel, access is established according to the following procedure:

- S-transceiver recognizes that the D-channel on the S-bus is active via $D = '0'$.
- S-transceiver transfers S-bus D-channel data transparently through to the upstream IOM[®]-2 bus.

Functional Description

2.3.6 Activation/Deactivation of IOM[®]-2 Interface

The deactivation procedure of the IOM[®]-2 interface is shown in Figure 31. After detecting the code DI (Deactivation Indication) the Q-SMINT[®]I responds by transmitting DC (Deactivation Confirmation) during subsequent frames and stops the timing signals after the fourth frame. The clocks stop at the end of the C/I-code in IOM[®]-2 channel 0.

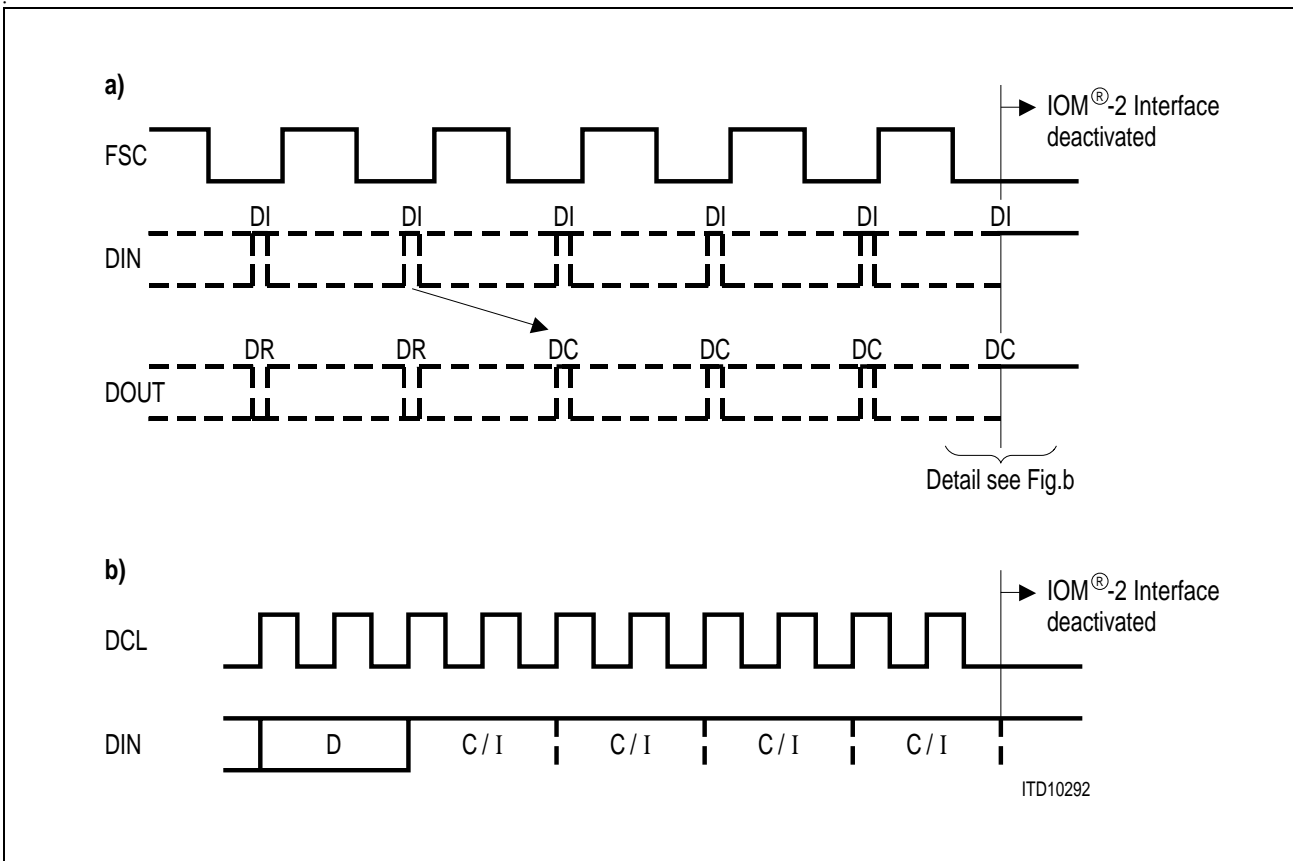

Figure 31 Deactivation of the IOM[®]-2 Clocks

Conditions for Power-Down

If none of the following conditions is true, the IOM[®]-2 interface can be switched off, reducing power consumption to a minimum.

- S-transceiver is not in state 'Deactivated'
- Signal $\overline{\text{INFO0}}$ on the S-interface
- Uk0-transceiver is not in state 'Deactivated'
- Pin DU is low (either at the IOM[®]-2 interface or via IOM_CR.SPU)
- External pin $\overline{\text{EAW}}$ External Awake is low
- Bit MODE 1.CFS = '0'
- Stop on the correct place in the IOM[®]-2 frame. DCL must be low during power down (stop on falling edge of DCL) (see [Figure 31](#)).

Functional Description

A deactivated IOM[®]-2 can be reactivated by one of the following methods:

- Pulling pin DU line low:
 - directly at the IOM[®]-2 interface
 - via the μ P interface with "Software Power Up" (IOM_CR:SPU bit)
- Pulling pin $\overline{\text{EAW}}$ 'External Awake' low
- Setting 'Configuration Select' MODE1:CFS bit = '0'
- Level detection at the S-interface
- Activation from the U-interface

2.4 U-Transceiver

The state machine of the U-Transceiver is based on the NT state machine in the PEB / PEF 8191 documentation [12].

Note: 'Self test request' and 'Self test passed' are not executed by the U-transceiver

The U-transceiver is configured and controlled via the registers described in [Chapter 4.11](#). The U-transceiver is always in IOM[®]-2 channel 0. It is possible to select between a state machine that simplifies programming (see [Chapter 2.4.10.6](#)) and the state machine as known from the PEB / PEF 8091 (see [Chapter 2.4.10.2](#)).

2.4.1 2B1Q Frame Structure

Transmission on the U_{2B1Q}-interface is performed at a rate of 80 kbaud. The code used is reducing two bits to one quaternary symbol (2B1Q).

Data is grouped together into U-superframes of 12 ms each. Each superframe consists of eight basic frames which begin with a synchronization word and contain 222 bits of information. The first basic frame of a superframe starts with an inverted synchword (ISW) compared to the other basic frames (SW). The structure of one U-superframe is illustrated in [Figure 32](#) and [Figure 33](#).



Figure 32 U-Superframe Structure

Functional Description

(I) SW (Inverted) Synch Word 18 Bit (9 Quat)	12 × 2B + D User Data 216 Bits (108 Quat)	M1 – M6 Maintenance Data 6 Bits (3 Quat)
<---1,5 ms--->		

Figure 33 U-Basic Frame Structure

Out of the 222 information bits 216 contain 2B + D data from 12 IOM[®]-frames, the remaining 6 bits are used to transmit maintenance information. Thus 48 maintenance bits are available per U-superframe. They are used to transmit two EOC-messages (24 bit), 12 Maintenance (overhead) bits and one checksum (12 bit).

Table 14 U-Superframe Format

		Framing	2B + D	Overhead Bits (M1 – M6)					
Quat Position s	Bit Position s	1 – 9	10 – 117	118 s	118 m	119 s	119 m	120 s	120 m
Super Frame #	Basic Frame #	Sync Word	2B + D	M1	M2	M3	M4	M5	M6
1	1	ISW	2B + D	EOC a1	EOC a2	EOC a3	ACT/ACT	1	1
	2	SW	2B + D	EOC dm	EOC i1	EOC i2	DEA / PS1	1	FEBE
	3	SW	2B + D	EOC i3	EOC i4	EOC i5	SCO/ PS2	CRC1	CRC2
	4	SW	2B + D	EOC i6	EOC i7	EOC i8	1/ NTM	CRC3	CRC4
	5	SW	2B + D	EOC a1	EOC a2	EOC a3	1/ CSO	CRC5	CRC6
	6	SW	2B + D	EOC dm	EOC i1	EOC i2	1	CRC7	CRC8

Functional Description

Table 14 U-Superframe Format (cont'd)

		Framing	2B + D	Overhead Bits (M1 – M6)					
	7	SW	2B + D	EOC i3	EOC i4	EOC i5	UOA / SAI	CRC9	CRC 10
	8	SW	2B + D	EOC i6	EOC i7	EOC i8	AIB / NIB	CRC 11	CRC 12
2,3...									
							LT- to NT dir. > /	< NT- to LT dir.	

- ISW Inverted Synchronization Word (quad): $- 3 - 3 + 3 + 3 + 3 - 3 + 3 - 3 - 3$
- SW Synchronization Word (quad): $+ 3 + 3 - 3 - 3 - 3 + 3 - 3 + 3 + 3$
- CRC Cyclic Redundancy Check
- EOC Embedded Operation Channel
 - a = address bit
 - d/m = data / message bit
 - i = information (data / message)
- ACT Activation bit ACT = (1) → Layer 2 ready for communication
- DEA Deactivation bit DEA = (0) → LT informs NT that it will turn off
- CSO Cold Start Only CSO = (1) → NT-activation with cold start only
- UOA U-Only Activation UOA = (0) → U-only activated
- SAI S-Activity Indicator SAI = (0) → S-interface is deactivated
- FEBE Far-end Block Error FEBE = (0) → Far-end block error occurred
- PS1 Power Status Primary Source PS1 = (1) → Primary power supply ok
- PS2 Power Status Secondary Source PS2 = (1) → Secondary power supply ok
- NTM NT-Test Mode NTM = (0) → NT busy in test mode
- AIB Alarm Indication Bit AIB = (0) → Interruption (according to ANSI)
- NIB Network Indication Bit NIB = (1) → no function (reserved for network use)
- SCO Start on Command only bit
- 1 (currently not defined by ANSI/ETSI)

can be accessed by the system interface for proprietary use

The principle signal flow is depicted in **Figure 34** and **Figure 35**. The data is first grouped in bits that are covered by the CRC and bits that are not. After the CRC generation the bits are arranged in the proper sequence according to the 2B1Q frame format, encoded and finally transmitted.

In receive direction the data is first decoded, descrambled, deframed and handed over for further processing.

Functional Description

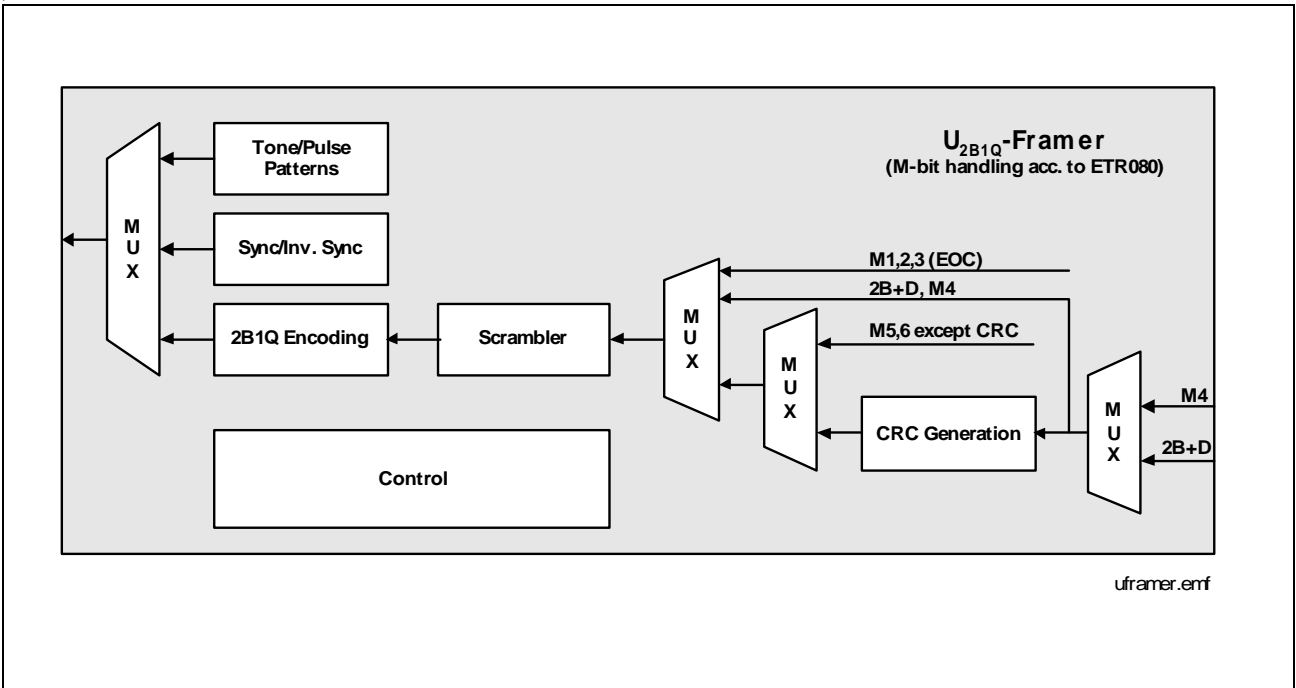

Figure 34 U_{2B1Q} Framer - Data Flow Scheme

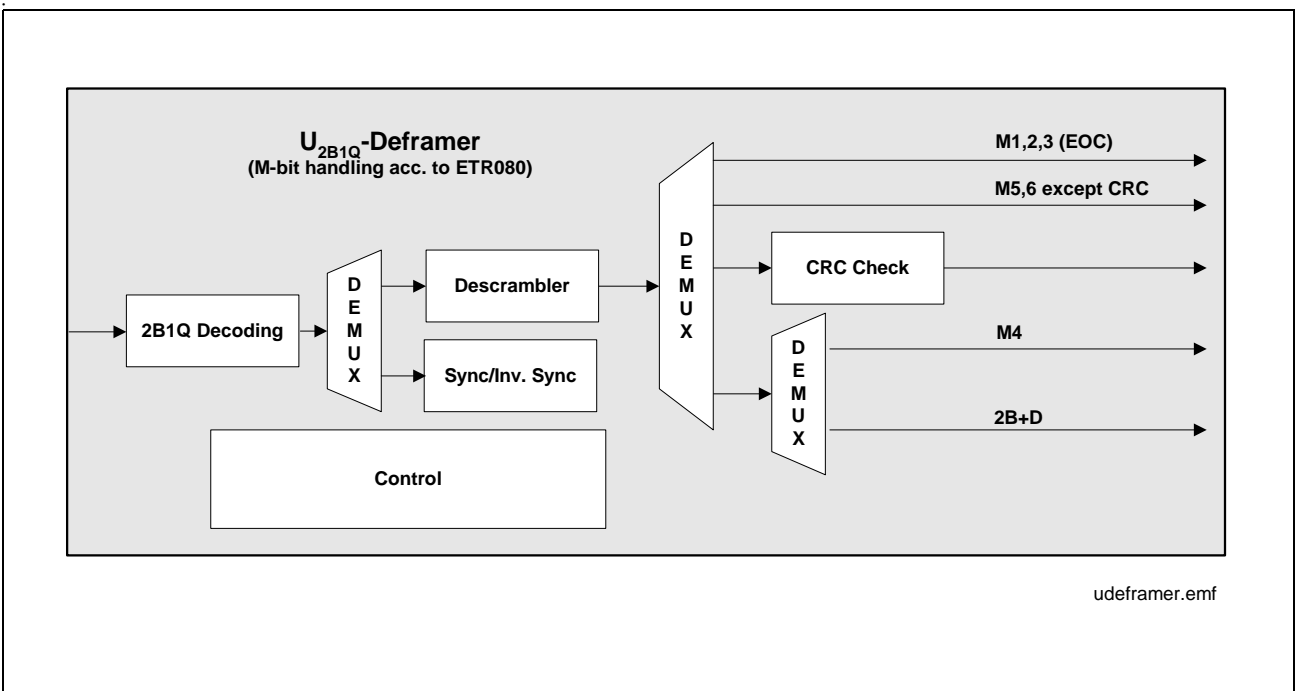

Figure 35 U_{2B1Q} Deframer - Data Flow Scheme

Functional Description

2.4.2 Maintenance Channel

The last three symbols (6 bits) of each basic frame are used as M (Maintenance)-channel for the exchange of operation and maintenance data between the network and the NT. Approved M-bit data is first processed and then reported to the μ C by interrupt requests. The verification method is programmed in the MFILT register (see [Chapter 4.11.2](#)).

EOC-data is inserted into the U-frame at the positions M1, M2 and M3 ([Table 14](#)) thereby permitting the transmission of two complete EOC-messages (2x 12 bits) within one U-superframe (see [Chapter 2.4.3](#)).

M4 bits are used to communicate status and maintenance functions between the transceivers. The meaning of a bit position is dependent upon the direction of transmission (upstream/downstream) and the operation mode (NT/LT). See [Table 14](#) for the different meaning of the M4 bits. For details see [Chapter 2.4.4](#).

The M5 and M6 bits contain the FEBE bit and the CRC bits. For details see [Chapter 2.4.6](#).

2.4.2.1 Reporting to the μ C Interface

The maintenance channel information is exchanged with external devices via the appropriate registers. Received maintenance channel information is reported to the μ C by an interrupt.

2.4.2.2 Access from the μ C Interface

The maintenance data to be transmitted can be programmed by writing the internal EOCW/M4W/M56W registers.

2.4.2.3 Availability of Maintenance Channel Information

Transmission of the Maintenance channel data is only possible if a superframe is transmitted and the M-bits are transparent (M-Bits are “normal” in [Table 24](#)). In other states all maintenance bits are clamped to high.

Reception of the Maintenance channel data is enabled by the state machine in the following states:

Table 15 Enabling the Maintenance Channel (Receive Direction)

Synchronized1
Synchronized2
Wait for ACT
Transparent
Error S/T

Functional Description

Table 15 Enabling the Maintenance Channel (Receive Direction)

Pend. Deac. S/T
Pend. Deac. U
Analog Loop Back

Reporting and execution of maintenance information is only sensible if the Q-SMINT[®] is synchronous. Filters are provided to avoid meaningless reporting.

Reset values are applied to the maintenance bits before the state machine enters one of the states in [Table 15](#).

2.4.2.4 M-Bit Register Access Timing

Since the maintenance data must be put into and read from the U-frame in time there is the need for synchronization if M-Bit data is exchanged via the μ C-interface. Below the timing is given for the access to the M-Bit read and write registers.

The **write access timing** is depicted in [Figure 36](#). Timing references for a write access are the 6 ms and 12 ms interrupts which are accommodated in the ISTAU register. An active 6 ms interrupt signals that from this event there is a time frame of 3 basic frames duration (4.5 ms) for the write access to the EOCW register.

The 12 ms interrupt serves as time reference for the write access to the M4W and M56W registers. From the point of time the 12 ms interrupt goes active there is a time window of 7 basic frames to overwrite the register values. The programmed data will be sent out with the next U-superframe.

Note that the point of time when the 6 ms and 12 ms interrupts are generated within basic frame #1 and #5 is not fixed and may vary.

Functional Description

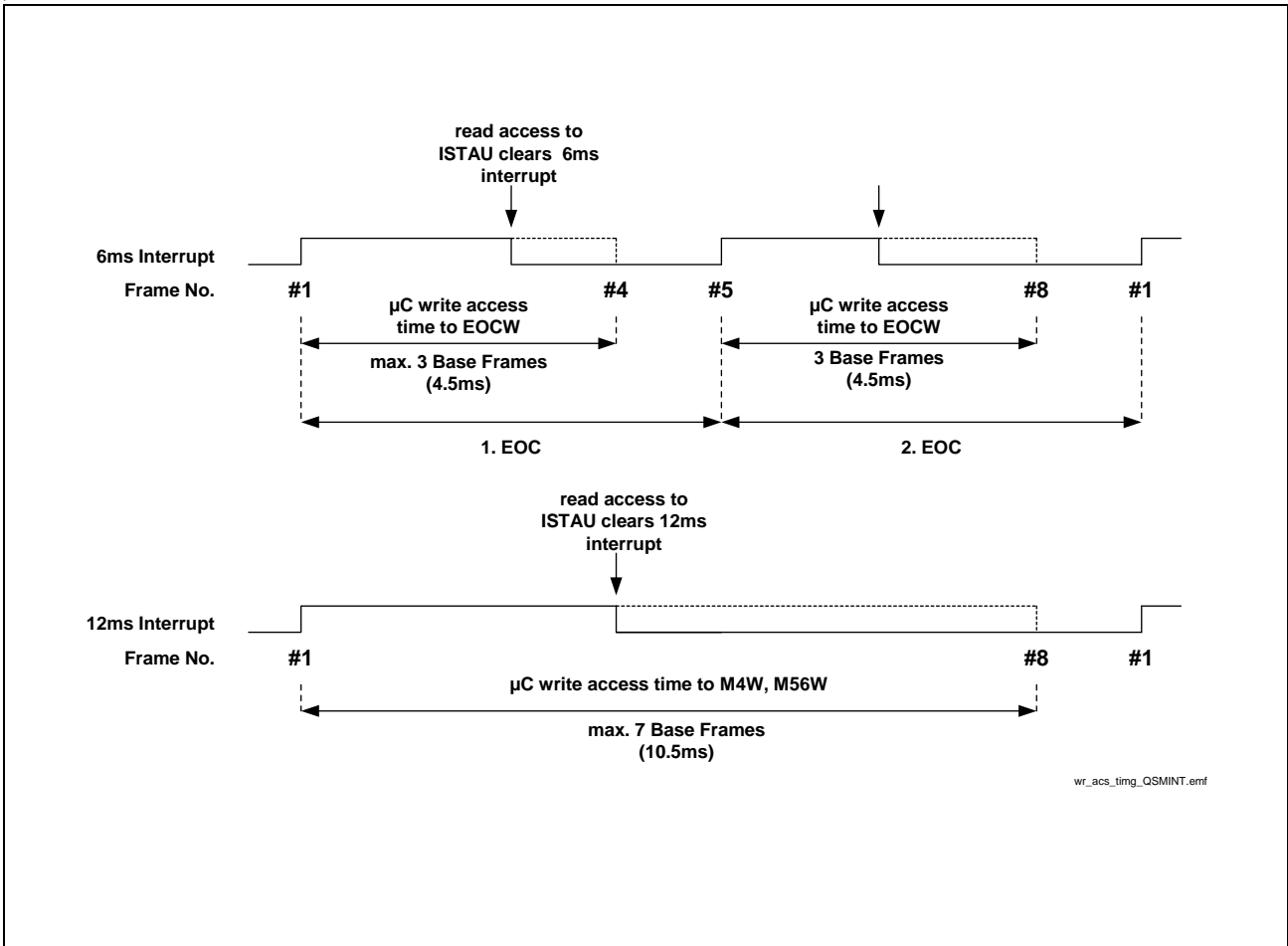

Figure 36 Write Access Timing

The **read access timing** is illustrated in [Figure 37](#). An interrupt source of the same name is associated with each read register (EOCR, M4R, M56R). An EOC interrupt indicates that the value of the EOCR register has been changed and updated. So do the M4 and M56 interrupts. Note that unlike the 6 ms and 12 ms interrupts the 'read' interrupts are only generated on change of the register value and do not occur periodically.

The EOC, M4 and M56 interrupt bits are all accommodated in the ISTAU register.

Functional Description

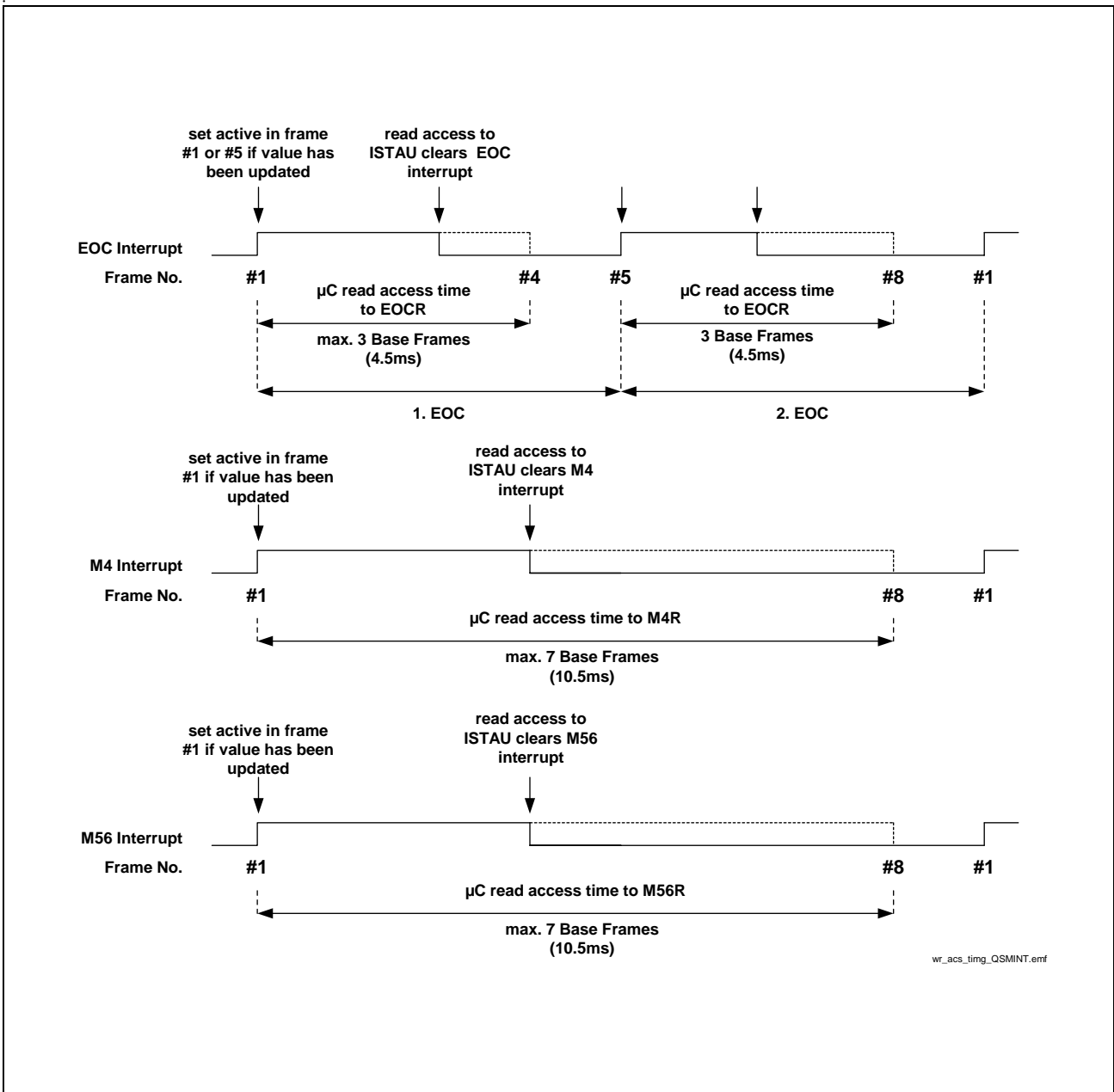

Figure 37 Read Access Timing

2.4.3 Processing of the EOC

2.4.3.1 EOC Commands

The EOC command consists of an address field, a data/message indicator and an eight-bit information field. With the address field the destination of the transmitted message/data is defined. Addresses are defined for the NT, 6 repeater stations and broadcasting.

Functional Description

The data/message indicator needs to be set to (1) to indicate that the information field contains a message. If set to (0), numerical data is transferred to the NT. Currently no numerical data transfer to or from the NT is required.

Table 16 Coding of EOC-Commands

EOC														
Address Field	Data/Message Indicator	Information						O (rigin) D (estination)		Message				
	a1a2a3	d/m	i1	i2	i3	i4	i5	i6	i7		i8	LT	NT	
0 0 0	x												NT	
1 1 1	x												Broadcast	
0 0 1 1 1 0	x												Repeater stations No. 1 – No. 6	
	0												Data	
	1												Message	
	1		0	1	0	1	0	0	0	0	0	O	D	LBBD
	1		0	1	0	1	0	0	0	1		O	D	LB1
	1		0	1	0	1	0	0	1	0		O	D	LB2
	1		0	1	0	1	0	0	1	1		O	D	RCC
	1		0	1	0	1	0	1	0	0		O	D	NCC
	1		1	1	1	1	1	1	1	1		O	D	RTN
	1		0	0	0	0	0	0	0	0		D/O	O/D	H
	1		1	0	1	0	1	0	1	0		D	O	UTC

Table 17 Usage of Supported EOC-Commands

Hex-code			Function
	i1-i8	D	
00	H	H	Hold. Provokes no change. The device issues Hold if no NT or broadcast address is used or if the d/m indicator is set to (0).
50	LBBD		Close complete loop-back (B1, B2, D). If this command is detected in NT EOC auto mode the C/I-code ARL is issued by the Q-SMINT [®] I U-transceiver.

Functional Description

Table 17 Usage of Supported EOC-Commands(cont'd)

Hex-code			Function
	i1-i8	D	
51	LB1		Closes B1 loop-back in NT. All B1-channel data will be looped back within the Q-SMINT [®] I U-transceiver. The bits LB1 and U/IOM [®] are set in the register LOOP.
52	LB2		Closes B2 loop-back in NT. All B2-channel data will be looped back within the Q-SMINT [®] I U-transceiver. The bits LB2 and U/IOM [®] are set in the register LOOP.
53	RCC		Request corrupt CRC. Upon receipt the Q-SMINT [®] I transmits corrupted (= inverted) CRCs upstream. This allows to test the near end block error counter on the LT-side. The far end block error counter at the Q-SMINT [®] I-side is stopped and Q-SMINT [®] I-error indications are retained.
54	NCC		Notify of corrupt CRC. Upon receipt of NCC the Q-SMINT [®] I-block error counters (near-end only) are disabled and error indications are retained. This prevents wrong error counts while corrupted CRCs are sent.
AA		UTC	Unable to comply. Message sent instead of an acknowledgment if an undefined EOC-command or d/m bit=0 was received by the Q-SMINT [®] I.
FF	RTN		Return to normal. With this command all previously sent EOC-commands will be released. The EOCW register is reset to its initial state (FF _H).
XX		ACK	Acknowledge. If a defined and correctly addressed EOC-command was received by the Q-SMINT [®] I, the Q-SMINT [®] I replies by echoing back the received command.

2.4.3.2 EOC Processor

The on-chip EOC-processor is responsible for the correct insertion and extraction of EOC-data on the U-interface. The EOC-processor can be programmed either to auto mode or to transparent modes (see [Chapter 2.4.3.3](#)).

[Figure 38](#) shows the registers and pins that are involved when EOC data is transmitted and received.

Functional Description

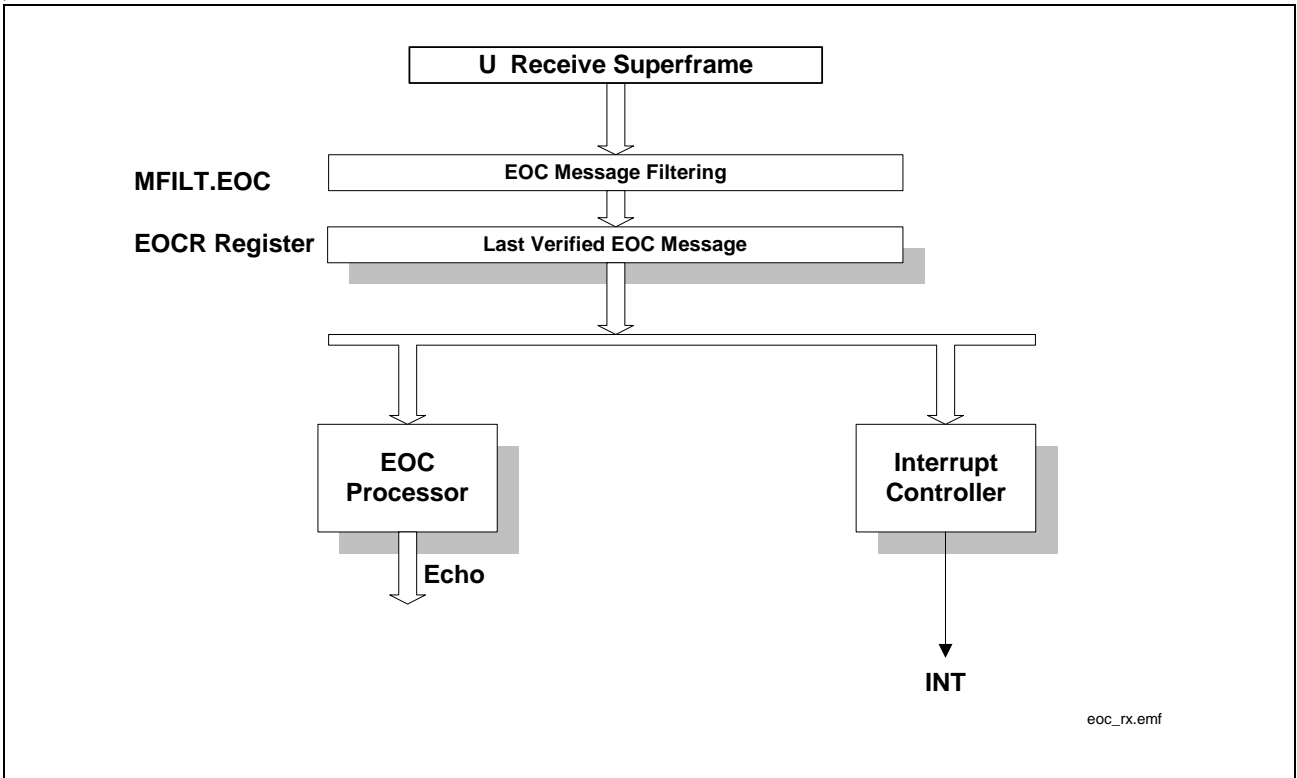

Figure 38 EOC Message Reception

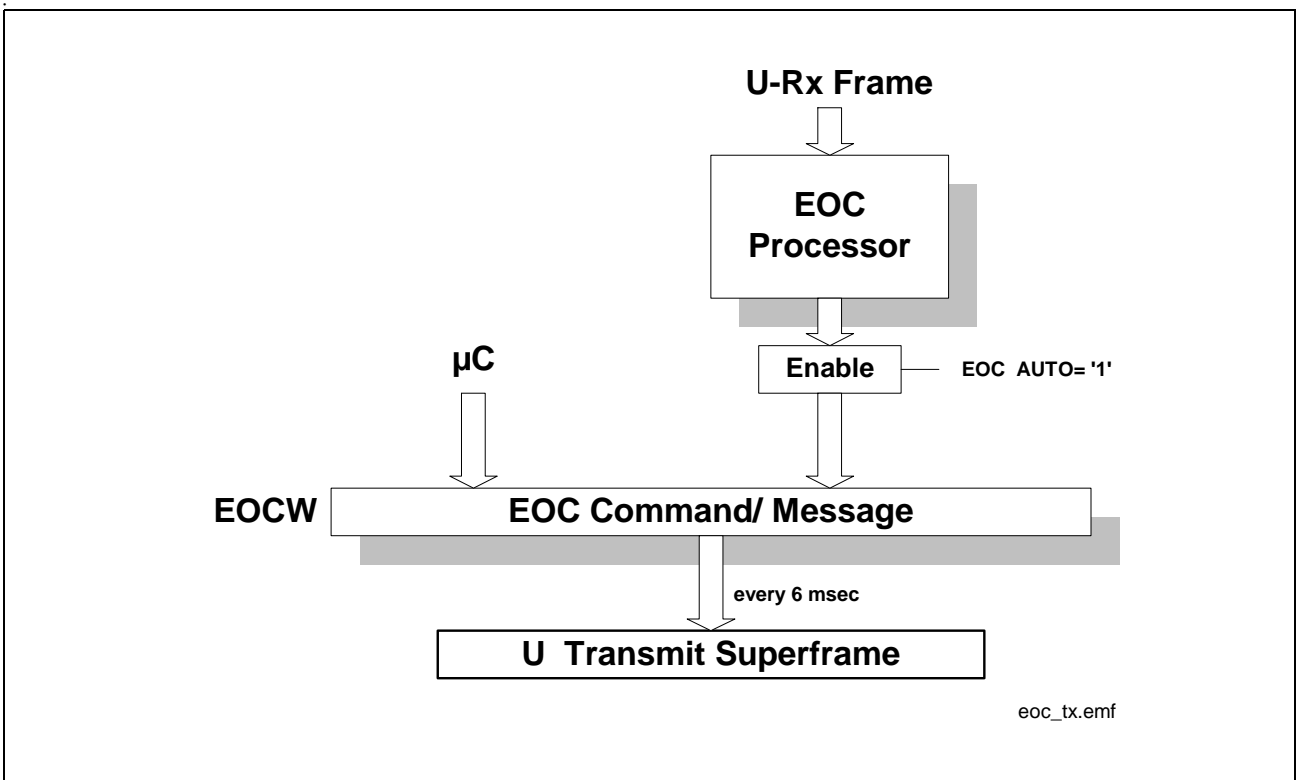

Figure 39 EOC Command/Message Transmission

Functional Description

2.4.3.3 EOC Operating Modes

The EOC operating modes are programmable in the MFILT register (see [Chapter 4.11.2](#))

EOC Auto Mode

- **Acknowledgement:** All received EOC-frames are echoed back to the exchange immediately without triple-last-look. If an address other than $(000)_B$ or $(111)_B$ is received, a HOLD message with address $(000)_B$ is returned. However there is an exception: The Q-SMINT[®]I will send a 'UTC' after three consecutive receptions of $d/m = 0$ or after an undefined command.
- **Latching:** All detected EOC-commands, i.e. LBB, RCC etc., are latched. Multiple subsequent valid EOC-commands are executed in parallel, as long as they are not disabled with the EOC 'RTN' command or a deactivation.
- **Reporting:** With the triple-last-look criterion fulfilled the new EOC-command will be reported by an interrupt, independently of the address used and the status of the d/m indicator. The triple last look criterion implies that the new verified message is different to the last TLL-verified message.
- **Execution:** The EOC-commands listed in [Table 16](#) will be executed automatically by the U-transceiver if they were addressed correctly (000_B or 111_B) and the d/m bit was set to message (1). The execution of a command is performed only after the "triple-last-look" criterion is met.

EOC Transparent Mode 6 ms

- **Acknowledgement:** There is no automatic acknowledgement in transparent mode. Therefore the external μC has to perform the EOC-Procedure. 2 msec must be available for the report and the subsequent access of the transmit EOC data of the next outgoing EOC-frame.
- **Latching:** No latching is performed due to no execution.
- **Reporting:** The received EOC-frame is reported to the μC by an interrupt every 6 ms. Verification, acknowledgment and execution of the received command have to be initiated by an external controller. The μC can program back all defined test functions (close/open loops, send corrupted CRCs). In the transmit direction, the last written EOC-code from the μC is used.
- **Execution:** No automatic execution in transparent modes. The appropriate actions can be programmed by the μC .

Functional Description

Transparent mode with 'On Change bit' active

- **Acknowledgment:** There is no automatic acknowledgement in transparent mode. For details see above.
- **Latching:** No latching is performed due to no execution.
- **Reporting:** This mode is almost identical to the Transparent Mode 6 ms. But a report to the μC by an interrupt takes place only, if a change in the EOC message has been detected.
- **Execution:** No automatic execution in transparent modes. The appropriate actions can be programmed by the μC .

Transparent mode with TLL active

- **Acknowledgement:** There is no automatic acknowledgment in transparent mode. For details see above.
- **Latching:** No latching is performed due to no execution.
- **Reporting:** This mode is almost identical to the Transparent Mode 6 ms. But a report to the μC by an interrupt takes place only, if the new EOC command has been detected in at least three consecutive EOC messages.
- **Execution:** No automatic execution in transparent modes. The appropriate actions can be programmed by the μC .

2.4.3.4 Examples for different EOC modes

General

In the following examples some letters like A,B,C are used to symbolize EOC command. There are also particular EOC commands mentioned which indicate special system behavior (e.g. UTC, H). The examples are shown in tables.

Functional Description

EOC Automode

Table 18 EOC Auto Mode

remarks																		
	immediately akcn.			immediately akcn.			NO report to system interface	wrong address -> H						undef. command or d/m=0				
input from μ C	Access to EOCW register has direct impact on EOC TX.																	
EOC TX	A	A	A	B	A	A	A	H	H	H	D	D	UTC	UTC	A	D	D	UTC
EOC RX	A	A	A	B	A	A	A	C	C	C	D	D	D	D	A	D	D	D
report to μ C			A							C			D					D

- A, B: EOC commands with correct address, d/m bit = 1 and defined command.
- C: EOC command with wrong address. Immediately acknowledged with H.
- D: EOC command which is not defined or d/m bit = 0. Acknowledgement after TLL with UTC.

Functional Description

Transparent mode 6 ms)

Table 19 Transparent mode 6 ms

remarks													
input from μ C	A				B			C			D		
EOC TX	A	A	A	A	B	B	B	C	C	C	D	D	D
EOC RX	C	A	B	C	C	A	A	A	A	B	B	B	B
report to μ C	C	A	B	C	C	A	A	A	A	B	B	B	B

Transparent mode '@change'

Table 20 Transparent mode '@change'

remarks													
input from μ C	A				B			C				D	
EOC TX	A	A	A	A	B	B	B	C	C	C	C	D	D
EOC RX	C	A	B	C	C	A	A	A	A	A	B	B	B
report to μ C		A	B	C		A					B		

Transparent mode TLL

Table 21 Transparent mode TLL

remarks																
				saturation											saturation	
input from μ C	A				B				C				D			
EOC TX	A	A	A	A	B	B	B	B	C	C	C	C	D	D	D	D
EOC RX	C	C	C	C	C	A	A	A	B	A	A	A	B	B	B	B
report to μ C			C				A				A			B		

Functional Description

2.4.4 Processing of the Overhead Bits M4, M5, M6

2.4.4.1 M4 Bit Reporting to the μ C

Four different validation modes can be selected and take effect on a **per bit base**. Only if the received M4 bit change has been approved by the programmed filter algorithm a report to the μ C is triggered. The following filter algorithms are provided and can be programmed in the MFILT register:

- On Change
- **Triple-Last-Look (TLL)** coverage
- **CRC** coverage

Note that unlike the M4 bits the M56 bits are not included in the CRC generation!

- **CRC and TLL** coverage

2.4.4.2 M4 Bit Reporting to State Machine

Some M4 bits, ACT, DEA and UOA, have two destinations, the state machine and the μ C. Regarding these bits Triple-Last-Look (TLL) is applied by default before the changed status is input to the state machine. Via the MFILT register the user can decide whether the M4 bits which are input to the state machine shall be approved

- by **TLL** (default setting, since TLL is a Bellcore requirement) or
- by the same verification mode as selected for reporting to the μ C.

The reset values before activation are ACT=0, DEA=1, UOA=0.

2.4.4.3 M5, M6 Bit Reporting to the μ C

By default changes in the received spare bits M51, M52, and M61 are reported to the μ C only if no CRC violation has been detected. However the user has the choice to program one of the following two options in the MFILT register (for details see [Chapter 4.11.2](#)):

- Same validation algorithm is applied to M5 and M6 bits as programmed for M4 bits
- **On Change**

In transmit direction these bits are set by default to '1' if they are not explicitly set by an μ C access (via M56W register).

2.4.4.4 Summary of M4, M5, M6 Bit Reporting

Figure 40 summarizes again the various filtering options that are provided for the several maintenance channel bits.

Functional Description

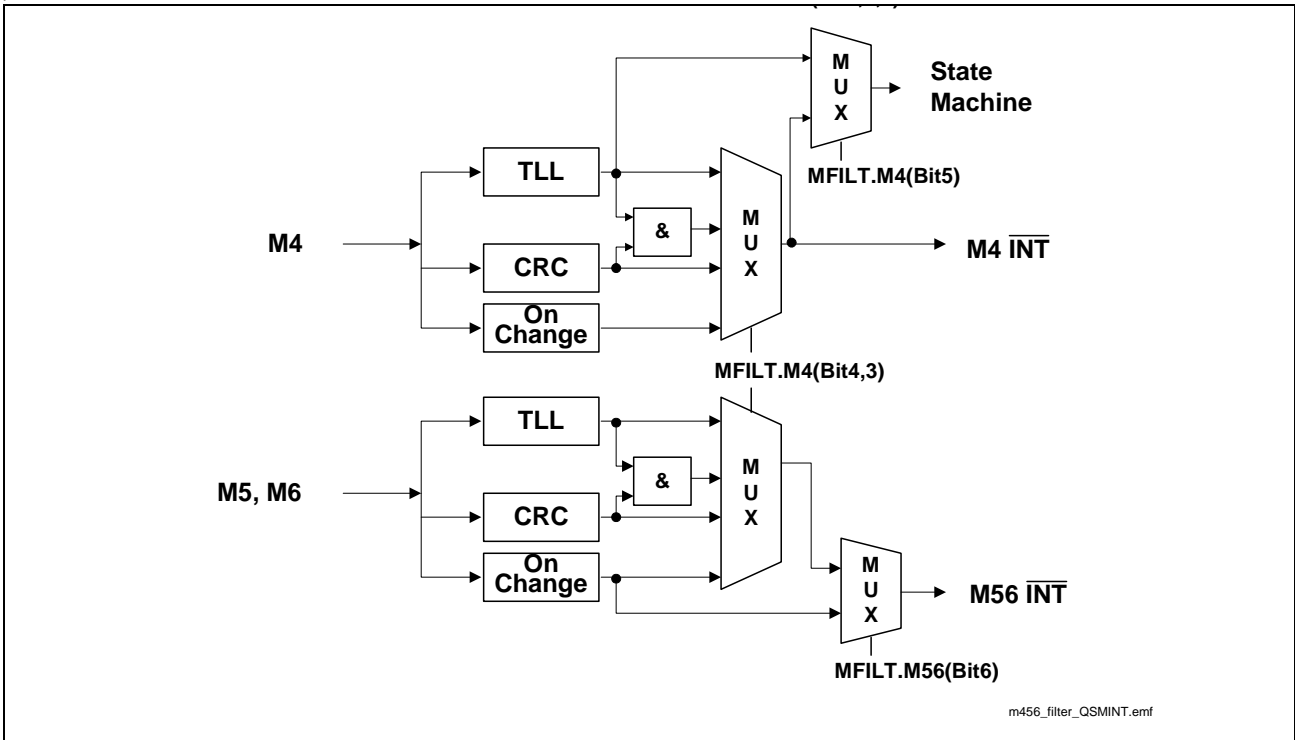

Figure 40 Maintenance Channel Filtering Options

Figure 41 illustrates the point of time when a detected M4, M5, M6 bit change is reported to the μ C and when it is reported to the state machine:

- towards the μ C reports are always sent after one complete U-superframe was received,
- whereas towards the state machine M4-bit changes (ACT, DEA, UOA, SAI) are instantly passed on as soon as they were approved. In context of Figure 41 this means that a verified ACT bit change is already reported at the end of basic frame #1 instead of the end of basic frame #8.

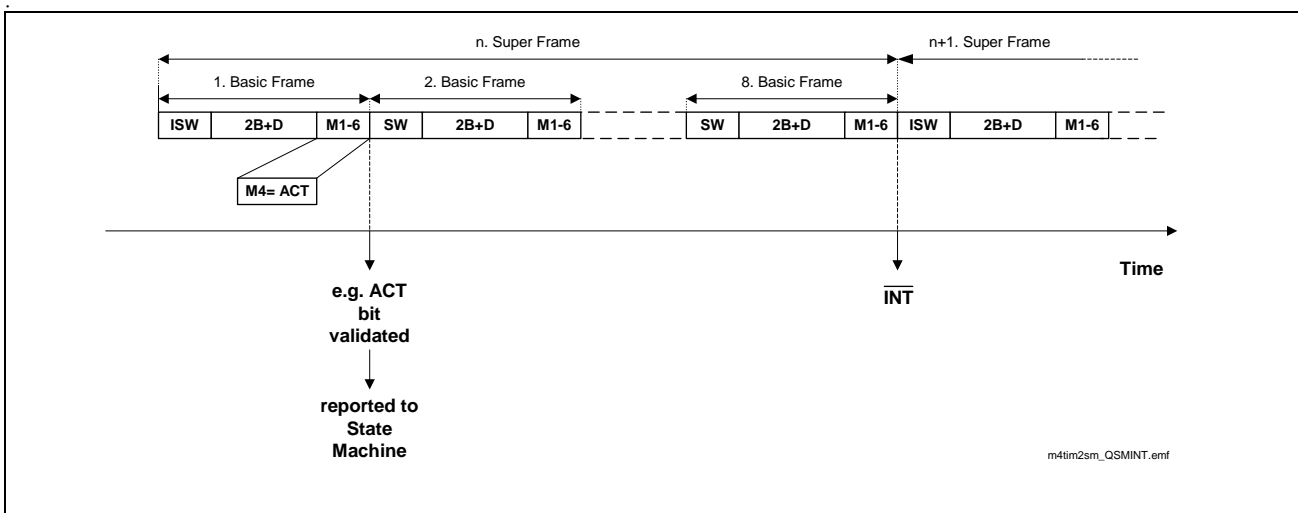

Figure 41 M4 Bit Report Timing (Statemachine vs. μ C)

Functional Description

However, if the same filter is selected towards the state machine as programmed towards the μC , the user has to be aware that if CRC mode is active, the state machine is informed at the end of the next U-superframe.

2.4.5 M4, M5, M6 Bit Control Mechanisms

Figure 42 and **Figure 43** show the control mechanisms that are provided for M4, M5 and M6 bit data:

Via the **M4WMASK** register the user can selectively program which M4 bits are externally controlled and which are set by the internal state machine or dedicated pins (PS1, PS2). If one M4WMASK bit is set to '0' then the M4 bit value in the U-transmit frame is determined by the bit value at the corresponding bit position in the M4W register.

Note: By bit 6 in the M4WMASK register it can be selected whether SAI is set by the state machine or by μC access and whether the value of the received UOA bit is reported to the state machine or UOA= '1' is signalled.

Via the **M4RMASK** register the user can selectively program which M4 bit changes shall cause an report to the μC .

The **M4W** register latches the M4 bits that are sent with the next available U-superframe.

The **M4R** register contains the last validated M4 bit data.

The default value of M51, M52 and M61 can be overwritten at any time by use of register **M56W**. **M56R** latches the last received and verified M5, M6 bit data.

The control of the FEBE bit is performed by the CRC-Processor, see **Chapter 2.4.6**.

Functional Description

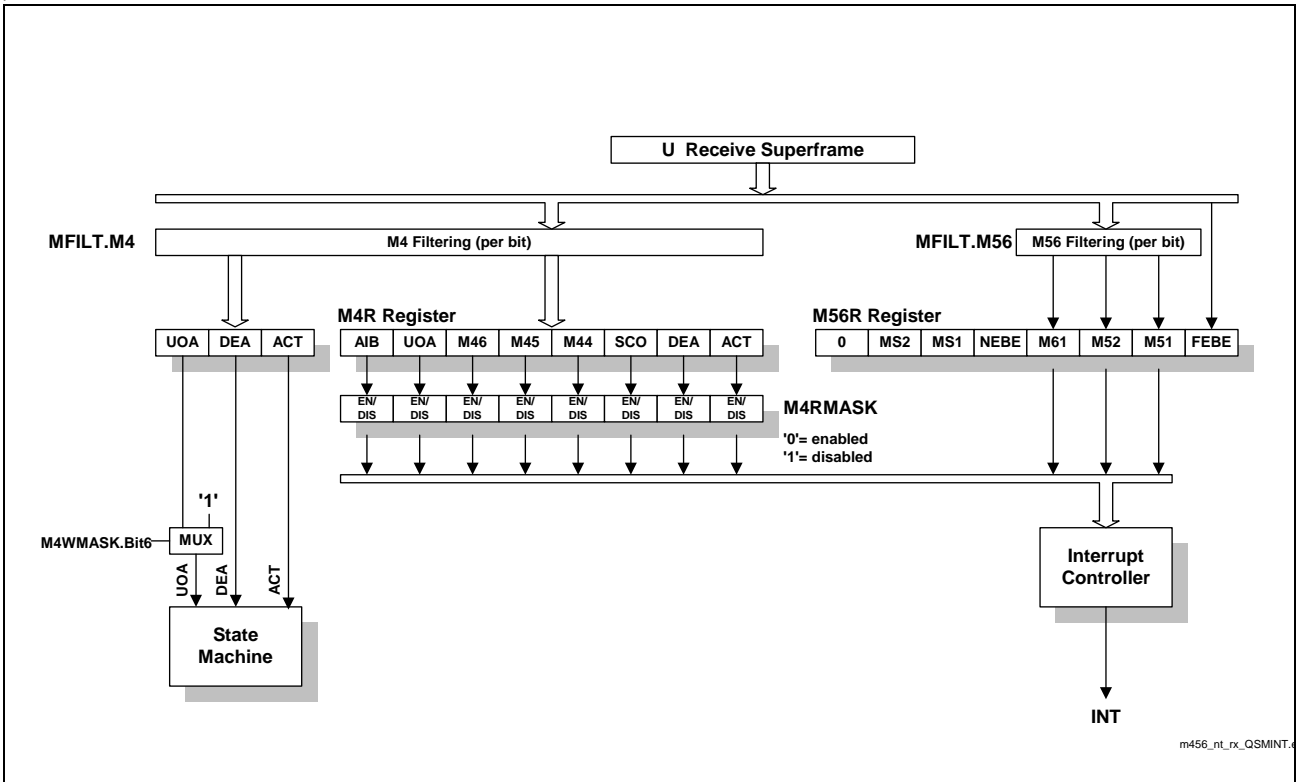

Figure 42 M4, M5, M6 Bit Control in Receive Direction

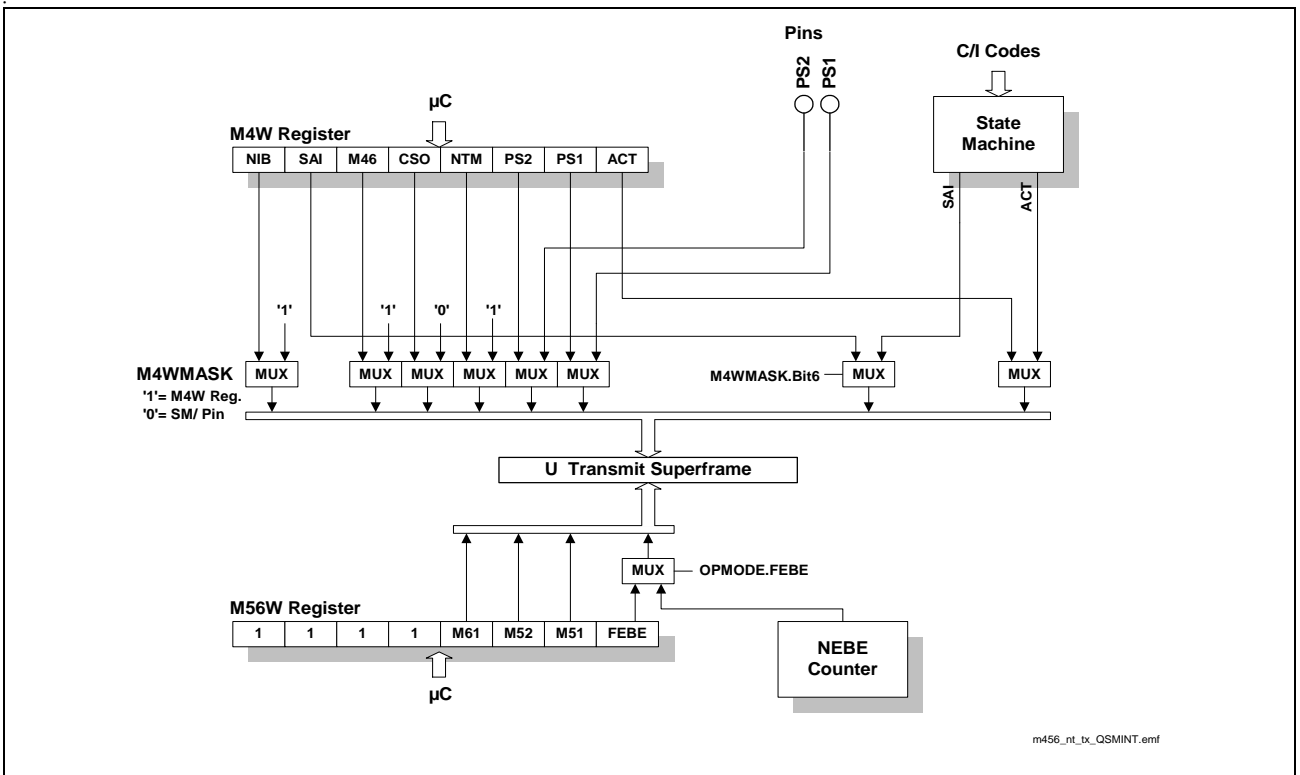

Figure 43 M4, M5, M6 Bit Control in Transmit Direction

Functional Description

2.4.6 Cyclic Redundancy Check / FEBE bit

An error monitoring function is implemented covering the 2B + D and M4 data transmission of a U-superframe by a Cyclic Redundancy Check (CRC).

The computed polynomial is:

$$G(u) = u^{12} + u^{11} + u^3 + u^2 + u + 1$$

(+ modulo 2 addition)

The check digits (CRC bits CRC1, CRC2, ..., CRC12) generated are transmitted in the U-superframe. The receiver will compute the CRC of the received 2B + D and M4 data and compare it with the received CRC-bits generated by the transmitter.

A CRC-error will be indicated to both sides of the U-interface, as a NEBE (Near-end Block Error) on the side where the error is detected, as a FEBE (Far-end Block Error) on the remote side. The FEBE-bit will be placed in the next available U-superframe transmitted to the originator.

Figure 44 illustrates the CRC-process.

Functional Description

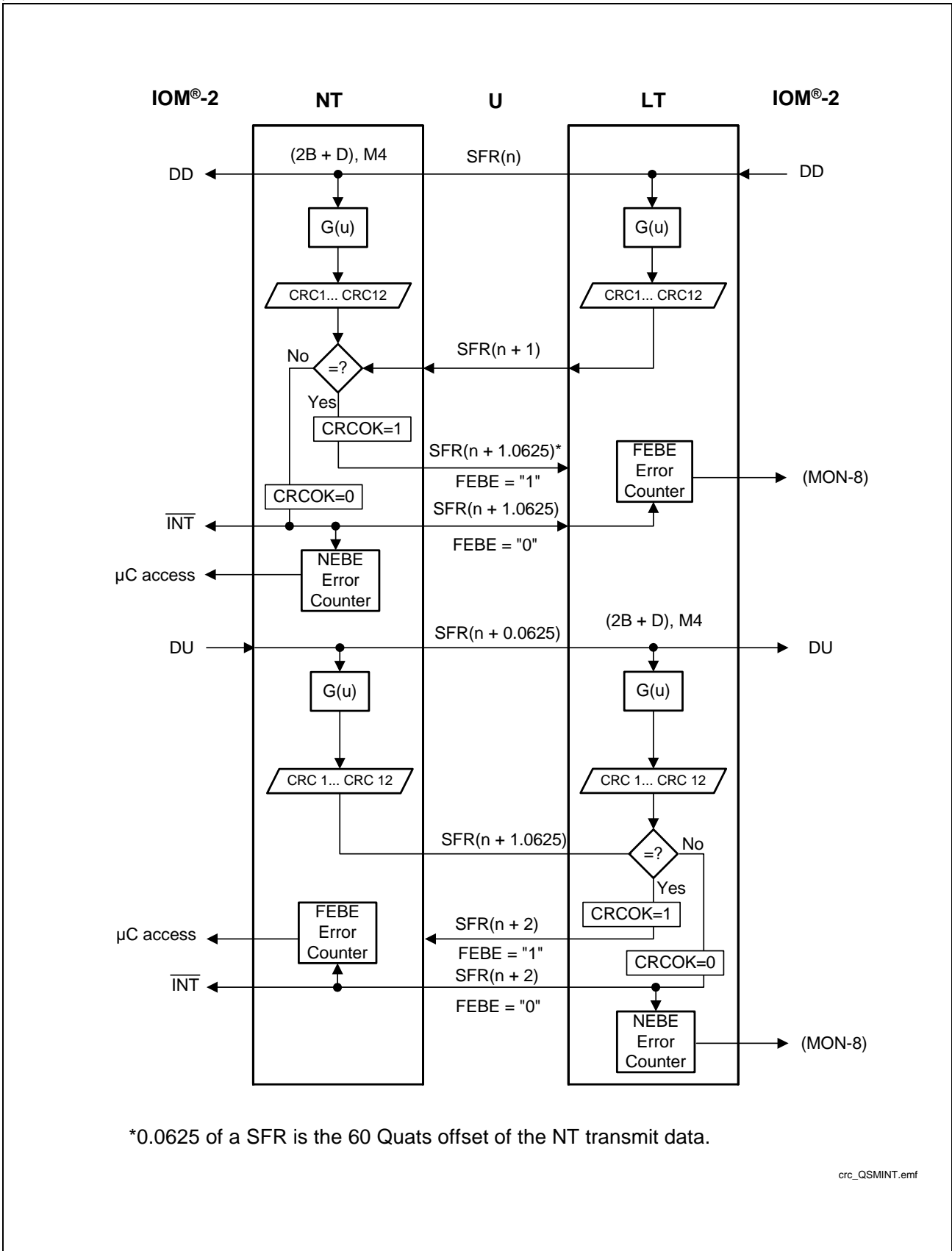

Figure 44 CRC-Process

Functional Description

2.4.7 Block Error Counters

The U-transceiver provides internal counters for far-end and near-end block errors. This allows a comfortable surveillance of the transmission quality at the U-interface. In addition, the occurrence of near-end errors, far-end errors, and the simultaneous occurrence of both errors are reported to the μC by an interrupt at the beginning of the following receive-superframe.

A block error is detected each time when the calculated checksum (CRC) of the received data does not correspond to the control checksum transmitted in the successive superframe. One block error thus indicates that one U-superframe has not been transmitted correctly. No conclusion with respect to the number of bit errors is therefore possible.

2.4.7.1 Near-End and Far-End Block Error Counter

A near-end block error (NEBE) indicates that the error has been detected in the receive direction (i.e. NEBE in the $\text{NT} = \text{LT} \Rightarrow \text{NT}$ error). Each detected NEBE-error increments the 8-bit NEBE-counter. When reaching the maximum count, counting is stopped and the counter value reads (FF_{H}).

A far-end block error identifies errors in transmission direction (i.e. FEBE in the $\text{NT} = \text{NT} \Rightarrow \text{LT}$ -error). FEBE errors are processed in the same manner as NEBE-errors.

The FEBE and NEBE counter values can be read in registers FEBE and NEBE. The counter is cleared after read. The counters are also reset to 00_{H} in all states except the states listed in [Table 15](#).

2.4.7.2 Testing Block Error Counters

[Figure 45](#) illustrates how near- and far-end block error counters can be tested. Transmission errors are simulated with artificially corrupted CRCs. With two commands the cyclic redundancy checksum can be inverted in the upstream and downstream direction. A third command offers to invert single FEBE-bits.

- **EOC Command NCC:**

Requests the Q-SMINT[®]I to notify corrupted CRCs.

The functional behavior of the Q-SMINT[®]I and the NEBE-counter depends on the mode selected:

- EOC auto mode:

NEBE-detection stopped: no NEBE interrupt generated and NEBE-counter disabled

- EOC transparent mode

NEBE-detection enabled: NEBE interrupt generated and NEBE-counter enabled

Functional Description

- **EOC Command RCC:**

Requests the Q-SMINT[®]I to send corrupt CRCs. After issuing RCC near-end block errors will be registered on the LT-side.

The functional behavior of the Q-SMINT[®]I and the FEBE-counter depends on the mode selected:

 - EOC auto mode:

The Q-SMINT[®]I will react with a permanently inverted upstream CRC.

FEBE-detection stopped: no FEBE interrupt generated and FEBE-counter disabled
 - EOC transparent mode
The external μ C must react on RCC by programming TEST.CCRC = '1'.
FEBE-detection enabled: FEBE interrupt generated and FEBE-counter enabled
- **EOC command RTN:**

Disables all previously sent EOC commands.
- **M56W.FEBE**

By setting / resetting M56W.FEBE (M56W.FEBE can only be set and controlled externally if OPMODE.FEBE is set to '1'), the FEBE bit of the next available U-frame can be set / reset . Therefore, it is possible to predict exactly the FEBE-counter value.

Functional Description

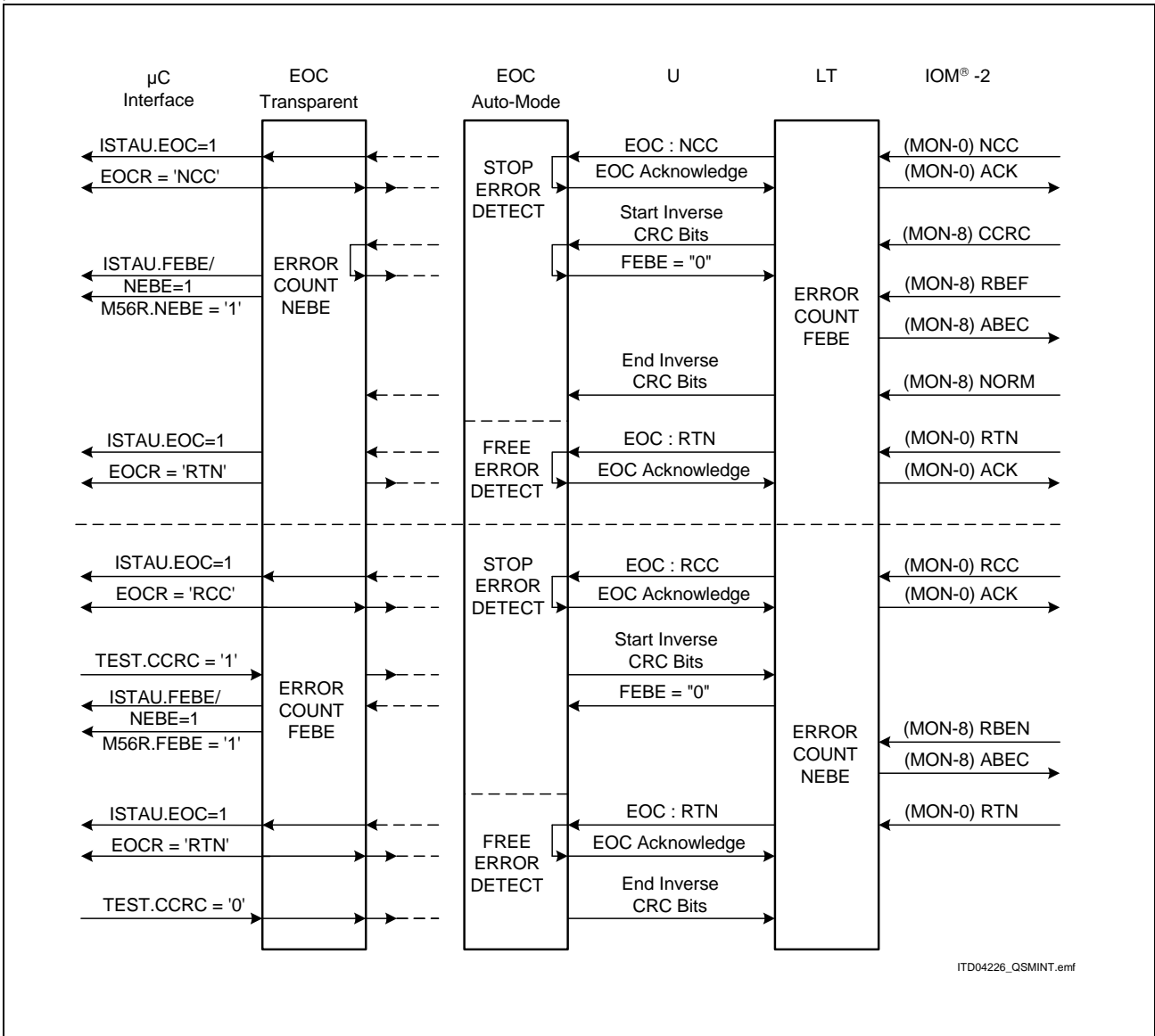

Figure 45 Block Error Counter Test

2.4.8 Scrambling/ Descrambling

The scrambling algorithm ensures that no sequences of permanent binary 0s or 1s are transmitted. The scrambling / descrambling process is controlled fully by the Q-SMINT[®]. Hence, no influence can be taken by the user.

2.4.9 C/I Codes

The operational status of the U-transceiver is controlled by the Control/Indicate channel (C/I-channel).

Functional Description

Table 22 presents all defined C/I codes. A new command or indication will be recognized as valid after it has been detected in two successive IOM[®]-2-frames (double last-look criterion).

Note: Unconditional C/I-Commands must be applied for at least 4 IOM[®]-2 frames for reliable recognition by the U-transceiver.

Commands have to be applied continuously on DU until the command is validated by the U-transceiver and the desired action has been initiated. Afterwards the command may be changed.

An indication is issued permanently by the U-transceiver on DD until a new indication needs to be forwarded. Because a number of states issue identical indications it is not possible to identify every state individually.

Table 22 U - Transceiver C/I Codes

Code	IN	OUT
0000	TIM	DR
0001	RES	–
0010	–	–
0011	–	–
0100	EI1	EI1
0101	SSP	–
0110	DT	–
0111	–	PU
1000	AR	AR
1001	–	–
1010	ARL	ARL
1011	–	–
1100	AI	AI
1101	–	–
1110	–	AIL
1111	DI	DC

AI: Activation Indication

AIL: Activation Indication Loop

AR: Activation Request

ARL: Activation Request Local Loop

Functional Description

DC: Deactivation Confirmation
DI: Deactivation Indication
DR: Deactivation Request
DT: Data Through test mode
EI1: Error Indication 1
PU: Power-Up
RES: Reset
SSP: Send Single Pulses test mode
TIM: Timing request

2.4.10 State Machines for Line Activation / Deactivation

2.4.10.1 Notation

The state machines control the sequence of signals at the U-interface that are generated during the start-up procedure. The informations contained in the following state diagrams are:

- State name
- U-signal transmitted
- Overhead bits transmitted
- C/I-code transmitted
- Transition criteria
- Timers

Functional Description

Figure 46 shows how to interpret the state diagrams.

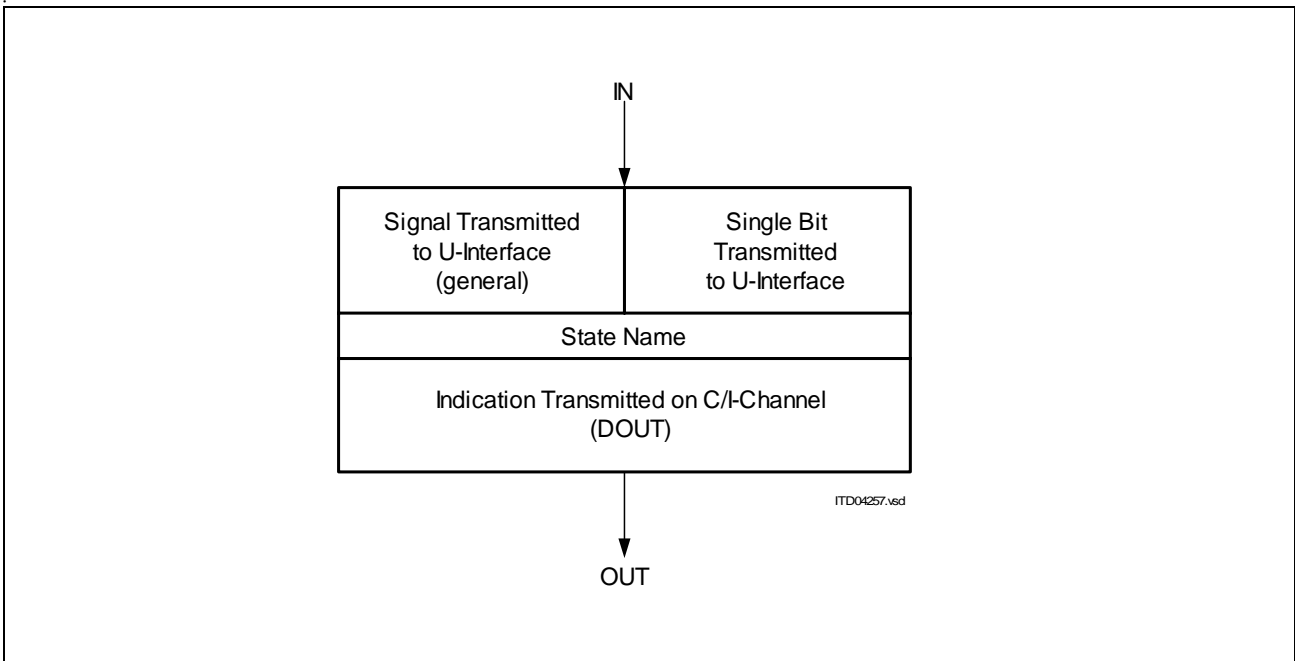

Figure 46 Explanation of State Diagram Notation

Combinations of transition criteria are possible. Logical “AND” is indicated by “&” (TN & DC), logical “OR” is written “or” and for a negation “/” is used. The start of a timer is indicated with “TxS” (“x” being equivalent to the timer number). Timers are always started when entering the new state. The action resulting after a timer has expired is indicated by the path labelled “TxE”.

Functional Description

Note: The test modes 'Data Through' (DT) and 'Send Single Pulses' (SSP) are invoked via C/I codes 'DT' and 'SSP' according to [Table 22](#). Setting SRES.RES_U to '1' forces the U-transceiver into test mode 'Quiet Mode' (QM), i.e. the U-transceiver is hardware reset.

If the Metallic Loop Termination is used, then the U-transceiver is forced into the states 'Reset' and 'Transparent' by valid pulse streams on pin MTI according to [Table 29](#).

Note: If the state machine is in state 'Deactivated' and the IOM[®]-2 clocks are not running, then the transitions to 'IOM[®]-2 Awaked' or 'Alerting' can be invoked by writing directly the corresponding C/I-code to register UCIW via the μ C interface.

2.4.10.3 Inputs to the U-Transceiver:

C/I-Commands:

AI	<p>Activation Indication</p> <p>The downstream device issues this indication to announce that its layer-1 is available. The U-transceiver informs the LT side by setting the "ACT" bit to "1".</p>
AR	<p>Activation Request</p> <p>The U-transceiver is requested to start the activation process by sending the wake-up signal TN.</p>
ARL	<p>Activation Request Local Loop-back</p> <p>The U-transceiver is requested to operate an analog loop-back (close to the U-interface) and to begin the start-up sequence by sending SN1 (without starting timer T1). This command may be issued only after the U-transceiver has been HW- or SW-reset. This eases that the EC- and EQ-coefficient updating algorithms converge correctly. The ARL-command has to be issued continuously as long as the loop-back is required.</p>
DI	<p>Deactivation Indication</p> <p>This indication is used during a deactivation procedure to inform the U-transceiver that it may enter the deactivated (power-down) state.</p>
DT	<p>Data Through</p> <p>This unconditional command is used for test purposes only and forces the U-transceiver into the "Transparent" state.</p>
EI1	<p>Error Indication 1</p> <p>The downstream device indicates an error condition (loss of frame alignment or loss of incoming signal). The U-transceiver informs the LT-side by setting the ACT-bit to "0" thus indicating that transparency has been lost.</p>
RES	<p>Reset</p> <p>Unconditional command which resets the U-transceiver.</p>
SSP	<p>Send Single Pulses</p> <p>Unconditional command which requests the transmission of single pulses on the U-interface.</p>

Functional Description

TIM Timing
 The U-transceiver is requested to enter state 'IOM[®]-2 Awaked'.

U-Interface Events:

- ACT = 0/1 ACT-bit received from LT-side.
- ACT = 1 requests the U-transceiver to transmit transparently in both directions. In the case of loop-backs, however, transparency in both directions of transmission is established when the receiver is synchronized.
 - ACT = 0 indicates that layer-2 functionality is not available.
- DEA = 0/1 DEA-bit received from the LT-side
- DEA = 0 informs the U-transceiver that a deactivation procedure has been started by the LT-side.
 - DEA = 1 reflects the case when DEA = 0 was detected by faults due to e.g. transmission errors and allows the U-transceiver to recover from this situation.
- UOA = 0/1 UOA-bit received from network side
- UOA = 0 informs the U-transceiver that only the U-interface is to be activated. The S/T-interface must be deactivated.
 - UOA = 1 requests the S/T-interface (if present) to activate.

Timers

The start of timers is indicated by TxS, the expiry by TxE. [Table 23](#) shows which timers are used:

Table 23 Timers Used

Timer	Duration (ms)	Function	State
T1	15000	Supervisor for start-up	
T7	40	Hold time	Receive reset
T11	9	TN-transmission	Alerting
T12	5500	Supervisor EC-converge	EC-training
T13	15000	Frame synchronization	Pend. receive reset
T14	0.5	Hold time	Pend. timing
T20	10	Hold time	Wait for SF

2.4.10.4 Outputs of the U-Transceiver:

The following signals and indications are issued on IOM[®]-2 (C/I-indications) and on the U-interface (predefined U-signals):

Functional Description

C/I-Indications

- AI Activation Indication
The U-transceiver has established transparency of transmission. The downstream device is requested to establish layer-1 functionality.
- AIL Activation Indication Loopback
The U-transceiver has established transparency of transmission. The downstream device is requested to establish a loopback #2.
- AR Activation Request
The downstream device is requested to start the activation procedure.
- ARL Activation Request Loop-back
The U-transceiver has detected a loop-back 2 command in the EOC-channel and has established transparency of transmission in the direction IOM[®]-2 to U-interface. The downstream device is requested to start the activation procedure and to establish a loopback #2.
- DC Deactivation Confirmation
Idle code on the IOM[®]-2-interface.
- DR Deactivation Request
The U-transceiver has detected a deactivation request command from the LT-side for a complete deactivation or a S/T only deactivation. The downstream device is requested to start the deactivation procedure.
- EI1 Error Indication 1
The U-transceiver has entered a failure condition caused by loss of framing on the U-interface or expiry of timer T1.

Signals on U-Interface

The signals SNx, TN and SP transmitted on the U-interface are defined in [Table 24](#).

Table 24 U-Interface Signals

Signal	Synch. Word (SW)	Superframe (ISW)	2B + D	M-Bits
TN ¹⁾	± 3	± 3	± 3	± 3
SN0	no signal	no signal	no signal	no signal
SN1	present	absent	1	1
SN2	present	absent	1	1
SN3	present	present	1	normal
SN3T	present	present	normal	normal
Test Mode				
SP ²⁾	test signal	test signal	test signal	test signal

Functional Description

Note: ¹⁾ Alternating ± 3 symbols at 10 kHz.

Note: ²⁾ 4 Options for the test signal can be selected by register TEST:

A 40 kHz signal composed by alternating +/-3 or +/-1 transmit pulses.

A series of single pulses spaced at intervals of 1.5 ms; Either alternating +/-1 or +/-3 pulses can be selected.

Input Signals of the State Machine and related U-Signals

The table below summarizes the input signals that control the NT state machine and that are extracted from the U-interface signal sequences.

LOF	Loss of framing This condition is fulfilled if framing is lost for 573 ms.
LSEC	Loss of signal behind echo canceller Internal Signal which indicates that the echo canceller has converged
LSU	Loss of Signal on U-Interface This signal indicates that a loss of signal level for a duration of 3 ms has been detected on the U-interface. This short response time is relevant in all cases where the NT waits for a response (no signal level) from the LT-side.
LSUE	Loss of Signal on U-Interface - Error condition After a loss of signal has been noticed, a 588 ms timer is started. When it has elapsed, the LSUE-criterion is fulfilled. This long response time (see also LSU) is valid in all cases where the NT is not prepared to lose signal level i.e. the LT has stopped transmission because of loss of framing, an unsuccessful activation, or the transmission line is interrupted.
FD	Frame Detected
SFD	Super Frame Detected
BBD0 / BBD1	BBD0/1 Detected These signals are set if either '1' (BBD1) or '0' (BBD0) were detected in 4 subsequent basic frames. It is used as a criterion that the receiver has acquired frame synchronization and both its EC- and EQ-coefficients have converged. BBD0 corresponds to the received signal SL2 in case of a normal activation, BBD1 corresponds to the internally received signal SN3 in case of analog loop back.
TL	Awake tone detected The U-transceiver is requested to start an activation procedure.

Functional Description

Signals on IOM[®]-2

The Data (B+B+D) is set to all '1's in all states besides the states listed in [Table 15](#).

Dependence of Outputs

- Outputs denoted with ¹⁾ in [Figure 47](#):
Signal output on U_{k0} depends on the received EOC command and on the history of the state machine according to [Table 25](#):

Table 25 Signal Output on U_{k0}

EOC Command	History of the State Machine	Signal output on U _{k0}
received 'LBBD'	no influence	SN3T
received no 'LBBD' or 'RTN' after an 'LBBD'	state 'Transparent' has not been reached previously during this activation procedure	SN3
	state 'Transparent' has been reached previously during this activation procedure	SN3T

- Outputs denoted with ²⁾ in [Figure 47](#):
C/I-code output depends on received EOC-command 'LBBD' according to [Table 26](#):

Table 26 C/I-Code Output

EOC Command	Synchroni zed 2	Wait for Act	Transparent	Error S/T
received no 'LBBD' or 'RTN' after an 'LBBD'	AR	AR	AI	AR
received 'LBBD'	ARL	ARL	AIL	ARL

- Outputs denoted with ³⁾ in [Figure 47](#):
In States 'Pend. Deact. S/T' and 'Pend. Deact. U' the ACT-bit output depends on its value in the previous state.
- The value of the issued SAI-bit depends on the received C/I-code: DI and TIM lead to SAI = 0, any other C/I-code sets the SAI-bit to 1 indicating activity of the downstream device.
- If state Alerting is entered from state Deactivated, then C/I-code 'PU' is issued, else C/I-code 'DC' is issued.

Functional Description

2.4.10.5 Description of the NT-States

The following states are used:

Alerting

The wake-up signal TN is transmitted for a period of T11 either in response to a received wake-up signal TL or to start an activation procedure on the LT-side.

Alerting 1

“Alerting 1” state is entered when a wake-up tone was received in the “Receive Reset” state and the deactivation procedure on the NT-side was not yet finished. The transmission of wake-up tone TN is started.

Analog Loop-Back

Transparency is achieved in both directions of transmission. This state can be left by making use of any unconditional command.

Deactivated

Only in state Deactivated the device may enter the power-down mode.

EC Training

The signal SN1 is transmitted on the U-interface to allow the NT-receiver to update the EC-coefficients. The automatic gain control (AGC), the timing recovery and the EQ updating algorithm are disabled.

EC-Training 1

The “EC-Training 1” state is entered if transmission of signal SN1 has to be started and the deactivation procedure on the NT-side is not yet finished.

EC-Training AL

The signal SN1 is transmitted on the U-interface to allow the NT-receiver to update the EC-coefficients. The automatic gain control (AGC), the timing recovery and the EQ updating algorithm are disabled.

EQ-Training

The receiver waits for signal SL1 or SL2 to be able to update the AGC, to recover the timing phase, to detect the synch-word (SW), and to update the EQ-coefficients.

Functional Description

Error S/T

The downstream device is in an error condition (EI1). The LT-side is informed by setting the ACT-bit to "0" (loss of transparency on the NT-side).

IOM[®]-2-Awaked

The U-transceiver is deactivated, but may not enter the power-down mode.

Pending Deactivation of S/T

The U-transceiver has received the UOA-bit at zero after a complete activation of the S/T-interface. The U-transceiver requests the downstream device to deactivate by issuing DR.

Pending Deactivation of U-Interface

The U-transceiver waits for the receive signal level to be turned off (LSU) to start the deactivation procedure.

Pending Receive Reset

The "Pending Receive Reset" state is entered upon detection of loss of framing on the U-interface or expiry of timer T1. This failure condition is signalled to the LT-side by turning off the transmit level (SN0). The U-transceiver then waits for a response (no signal level LSU) from the LT-side.

Pending Timing

In the NT-mode the pending timing state assures that the C/I-channel code DC is issued four times before entering the 'Deactivated' state.

Receive Reset

In state 'Receive Reset' a reset of the Uk0-receiver is performed, except in case that state 'Receive Reset' was entered from state 'Pend. Deact. U'. Timer T7 assures that no activation procedure is started from the NT-side for a minimum period of time of T7. This gives the LT a chance to activate the NT.

Reset

In state 'Reset' a software-reset is performed.

Synchronized 1

State 'Synchronized 1' is the fully active state of the U-transceiver, while the downstream device is deactivated.

Functional Description

Synchronized 2

In this state the U-transceiver has received $UOA = 1$. This is a request to activate the downstream device.

Test

The test signal SP is issued as long as $C/I=SSP$ is applied. For further details see [Table 24](#).

Transparent

This state is entered upon the detection of $ACT = 1$ received from the LT-side and corresponds to the fully active state.

Wait for ACT

Upon the receipt of AI, the NT waits for a response ($ACT = 1$) from the LT-side.

Wait for SF

The signal SN2 is sent on the U-interface and the receiver waits for detection of the superframe.

Wait for SF AL

This state is entered in the case of an analog loop-back and allows the receiver to update the AGC, to recover the timing phase, and to update the EQ-coefficients.

2.4.10.6 Simplified NT State Machine

As an alternative to the activation/deactivation state machine of the U-transceiver known from the IEC-Q [9], a more software friendly state machine can be selected.

In the early days of ISDN, the activation and deactivation procedure in a NT was completely determined by the U- and S-transceiver state machines without a microcontroller being necessary. Intelligent NTs or U-terminals require a microcontroller and software. In this case the software controls both the S-and the U-transceiver state machine.

The simplified U-transceiver state machine was developed to better address the needs and requirements of software running on the microcontroller. The simplified state machine offers the following advantages:

- the software can tell whether the IOM[®]-2 clocks are active or powered down via the received C/I code
- From the received C/I code the software always knows, what it is expected to do and what options it has. The software does not have to backtrack older C/I codes.

Functional Description

- unnecessary C/I changes at irrelevant state transitions are omitted, hence the number of interrupts is reduced.

All advantages can be offered by the following minor changes to the existing state machine:

Table 27 Changes to achieve Simplified NT State Machine

Change	State	Standard NT State Machine	Simplified NT State Machine
Change of Transmitted C/I -Code			
	Alerting	DC/PU	PU
	EC-Training	DC	PU
	EQ-Training	DC	PU
	Wait for SF	DC	PU
	Synchronized 1	DC	PU
	Pend. Receive Res.	EI1	DR
	Pend. Deact. U.	DC	DR
	Wait for SF AL	DC	DR
	EC-Training AL	DC	DR
	all other States	no changes	

Changed State Transition Criteria

	Alerting 1 to Alerting	DI	DI or TIM
	EC-Training 1 to EC-Training	DI	DI or TIM
	Pend. Deact. S/T to Synchron. 1	DI	DI or TIM
	all other transition criterias	no changes	

New State Transitions

	Receive Reset to IOM [®] -2 Awaked	none	T7E & TIM
	Reset to IOM [®] -2 Awaked	none	TIM

Functional Description

Table 27 Changes to achieve Simplified NT State Machine(cont'd)

Change	State	Standard NT State Machine	Simplified NT State Machine
	Test to IOM [®] -2 Awaked	none	TIM

Not Supported State Transitions

	Reset to Alerting	DI & NTAUTO	none
	all other transitions	no changes	

Functional Description

Table 28 Appearance of the State Machine to the Software

C/I ind.	Meaning	Options		U-transparent
DR	LT has decided to deactivate or activation was lost: <ul style="list-style-type: none"> – after an activation or – after an activation attempt or – after reset 	DI TIM	Acknowledge and give permission to turn off the clocks Acknowledge, clocks will stay active	no
DC	four IOM [®] -2 frames with C/I code DC are issued before permission to turn off the clocks	TIM AR any other C/I-code	turn on clocks start U-activation no action, permission to turn off the clocks will be given	no
PU	clocks are on; U-interface is not transparent but may be synchronous (e.g. U-only activation)	any C/I-code	no action, clocks will remain on	no
AR	used during activation. U-interface is synchronous and is waiting for an ok from the downstream device	AI	accept that activation can continue, layer 2 of the downstream device is ready. Then wait for CI/ indication AI	no
AI	U-interface transparent	-- EI1 or act=0	no action, transmit data report problem on downstream device	yes

2.4.11 Metallic Loop Termination

For North American applications a maintenance controller according to ANSI T1.601 section 6.5 is implemented. The maintenance pulse stream from the U-interface Metallic Loop Termination circuit (MLT) is fed to pin MT1, usually via an optocoupler. It is digitally filtered for 20 ms and decoded independently on the polarity by the maintenance controller according to [Table 29](#). Therefore, the maintenance controller is capable of detecting the DC and AC signaling format. The Q-SMINT[®]I automatically sets the U-transceiver in the proper state and issues an interrupt. The state selected by the MLT is indicated via two bits.

The Q-SMINT[®]I reacts on a valid pulse stream independently of the current U-transceiver state. This includes the power-down state.

Functional Description

A test mode is valid for 75 seconds. If during the 75 seconds a valid pulse sequence is detected the 75 s timer starts again. After expiry of the 75 s timer the MLT maintenance controller goes back to normal operation.

Table 29 ANSI Maintenance Controller States

Number of counted pulses	ANSI maintenance controller state	U-transceiver State Machine
≤ 5	ignored	no impact
6	Quiet Mode	transition to state 'Reset' start timer 75s
7	ignored	no impact
8	Insertion Loss Measurement	transition to state 'Transparent' start timer 75s
9	ignored	no impact
10	normal operation	transition to state 'Reset'
≥ 11	ignored	no impact

Figure 49 shows examples for pulse streams with inverse polarity selecting Quiet Mode.

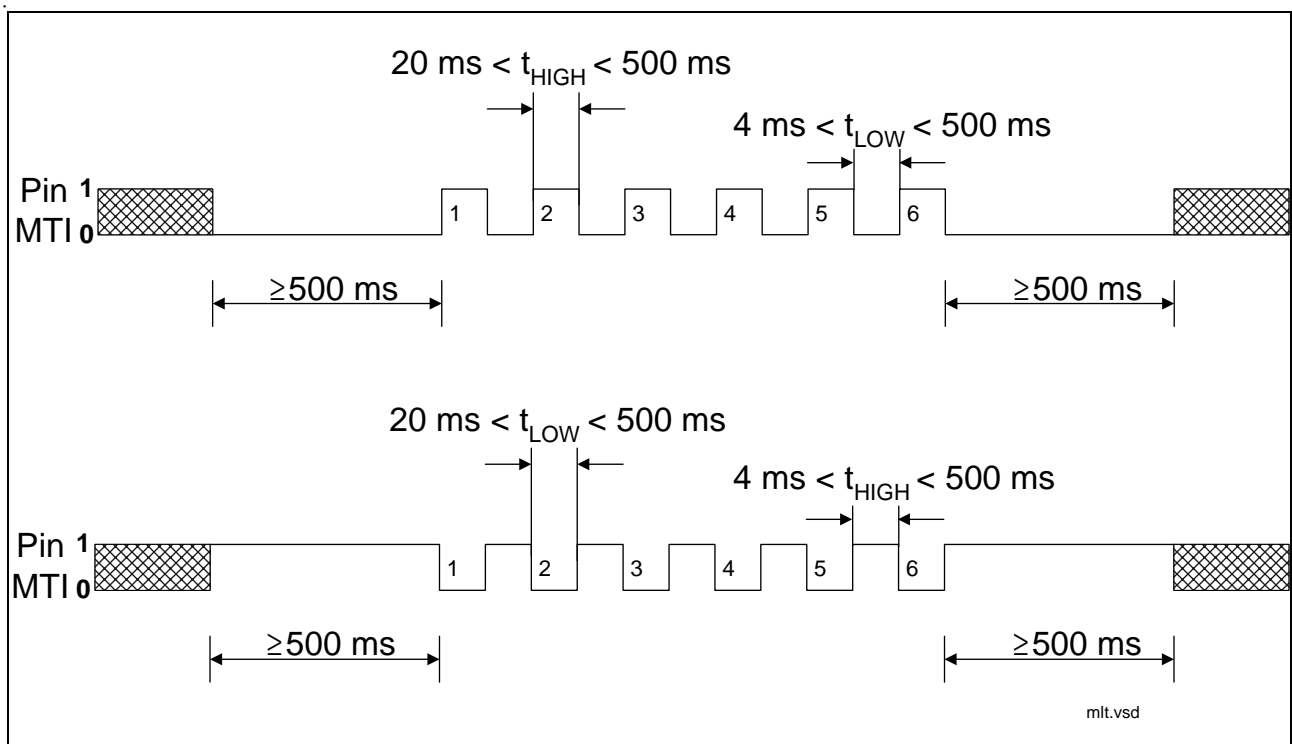

Figure 49 Pulse Streams Selecting Quiet Mode

Functional Description

2.4.12 U-Transceiver Interrupt Structure

The U-Interrupt Status register (ISTAU) contains the interrupt sources of the U-Transceiver (**Figure 50**). Each source can be masked by setting the corresponding bit of the U-Interrupt Mask register (MASKU) to '1'. Such masked interrupt status bits are not indicated when ISTAU is read and do not generate an interrupt request.

The ISTAU register is cleared on read access. The interrupt sources of the ISTAU register (UCIR, EOQR, M4R, M56R) need not be evaluated.

When at time t_1 an interrupt source generates an interrupt, all further interrupts are collected. Reading the ISTAU register clears all interrupts set before t_1 , even if masked. All interrupts, which are flagged after t_1 remain active. After the ISTAU read access, the next unmasked interrupt will generate the next interrupt at time t_2 . After t_2 it is possible to reprogram the MASKU register, so that all interrupts, which arrived between t_1 and t_2 are accessible.

Functional Description

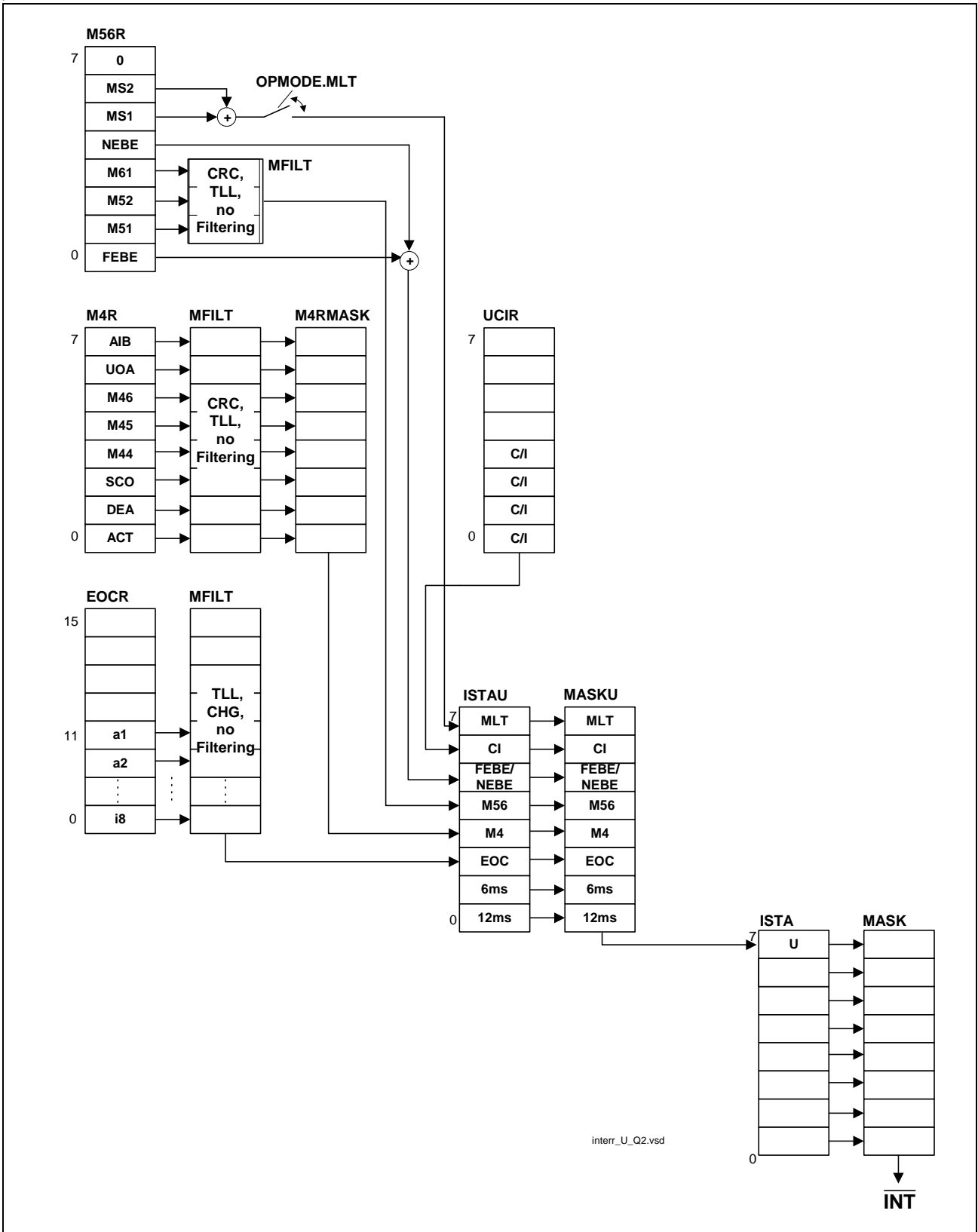

Figure 50 Interrupt Structure U-Transceiver

Functional Description

2.5 S-Transceiver

The S-Transceiver offers the NT and LT-S mode state machines described in the User’s Manual V3.4 [10].

The S-transceiver lies in IOM[®]-2 channel 1 (default) and is configured and controlled via the registers described in [Chapter 4.7](#). The state machine is set to NT mode (default) but can be set to LT-S mode via register programming.

The TE mode (S-transceiver TE mode, U-transceiver disabled) is not supported.

2.5.1 Line Coding, Frame Structure

Line Coding

The following figure illustrates the line code. A binary ONE is represented by no line signal. Binary ZEROs are coded with alternating positive and negative pulses with two exceptions:

For the required frame structure a code violation is indicated by two consecutive pulses of the same polarity. These two pulses can be adjacent or separated by binary ONES. In bus configurations a binary ZERO always overwrites a binary ONE.

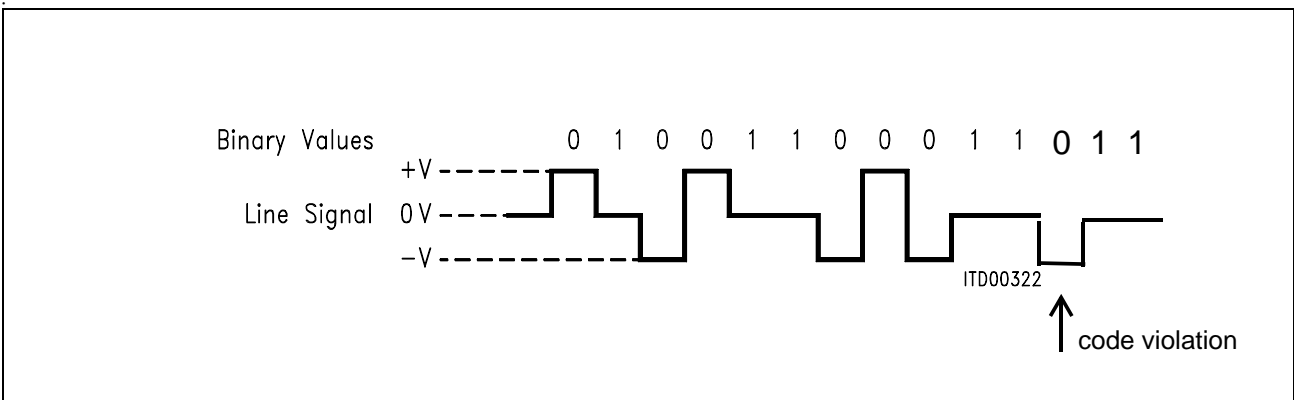

Figure 51 S/T -Interface Line Code

Frame Structure

Each S/T frame consists of 48 bits at a nominal bit rate of 192 kbit/s. For user data (B1+B2+D) the frame structure applies to a data rate of 144 kbit/s (see [Figure 51](#)).

In the direction TE → NT the frame is transmitted with a two bit offset. For details on the framing rules please refer to ITU I.430 section 6.3. The following figure illustrates the standard frame structure for both directions (NT → TE and TE → NT) with all framing and maintenance bits.

Functional Description

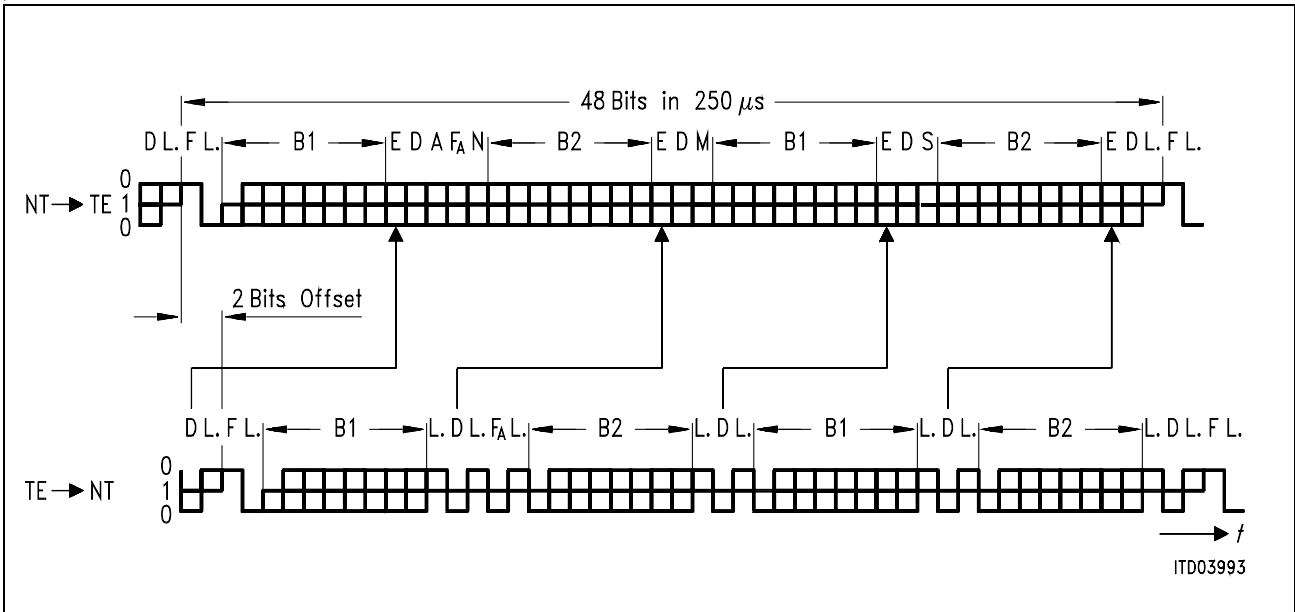

Figure 52 Frame Structure at Reference Points S and T (ITU I.430)

- F Framing Bit $F = (0b) \rightarrow$ identifies new frame (always positive pulse, always code violation)
- L. D.C. Balancing Bit $L. = (0b) \rightarrow$ number of binary ZEROs sent after the last L. bit was odd
- D D-Channel Data Bit Signaling data specified by user
- E D-Channel Echo Bit $E = D \rightarrow$ received E-bit is equal to transmitted D-bit
- F_A Auxiliary Framing Bit See section 6.3 in ITU I.430
- N $N = \overline{F_A}$
- B1 B1-Channel Data Bit User data
- B2 B2-Channel Data Bit User data
- A Activation Bit $A = (0b) \rightarrow$ INFO 2 transmitted
 $A = (1b) \rightarrow$ INFO 4 transmitted
- S S-Channel Data Bit S_1 channel data (see note below)
- M Multiframing Bit $M = (1b) \rightarrow$ Start of new multi-frame

Note: The ITU I.430 standard specifies $S1 - S5$ for optional use.

Functional Description

2.5.2 S/Q Channels, Multiframe

According to ITU recommendation I.430 a multi-frame provides extra layer-1 capacity in the TE-to-NT direction through the use of an extra channel between the TE and NT (Q-channel). The Q bits are defined to be the bits in the F_A bit position.

In the NT-to-TE direction the S-channel bits are used for information transmission.

The S- and Q-channels are accessed via μC by reading/writing the SQR or SQX bits in the S/Q channel registers (SQRR, SQXR).

Table 30 shows the S and Q bit positions within the multi-frame.

Table 30 S/Q-Bit Position Identification and Multi-Frame Structure

Frame Number	NT-to-TE F_A Bit Position	NT-to-TE M Bit	NT-to-TE S Bit	TE-to-NT F_A Bit Position
1	ONE	ONE	S11	Q1
2	ZERO	ZERO	S21	ZERO
3	ZERO	ZERO	S31	ZERO
4	ZERO	ZERO	S41	ZERO
5	ZERO	ZERO	S51	ZERO
6	ONE	ZERO	S12	Q2
7	ZERO	ZERO	S22	ZERO
8	ZERO	ZERO	S32	ZERO
9	ZERO	ZERO	S42	ZERO
10	ZERO	ZERO	S52	ZERO
11	ONE	ZERO	S13	Q3
12	ZERO	ZERO	S23	ZERO
13	ZERO	ZERO	S33	ZERO
14	ZERO	ZERO	S43	ZERO
15	ZERO	ZERO	S53	ZERO
16	ONE	ZERO	S14	Q4
17	ZERO	ZERO	S24	ZERO
18	ZERO	ZERO	S34	ZERO
19	ZERO	ZERO	S44	ZERO
20	ZERO	ZERO	S54	ZERO
1	ONE	ONE	S11	Q1
2	ZERO	ZERO	S21	ZERO

Functional Description

The S-transceiver starts multiframing if SQXR1.MFEN is set.

After multi-frame synchronization has been established in the TE, the Q data will be inserted at the upstream (TE → NT) F_A bit position by the TE in each 5th S/T frame, the S data will be inserted at the downstream (NT → TE) S bit position in each 5th S/T frame (see [Table 30](#)). Access to S2-S5-channel is not supported.

Interrupt Handling for Multi-Framing

To trigger the microcontroller for a multi-frame access an interrupt can be generated once per multi-frame (SQW) or if the received Q-channel have changed (SQC). In both cases the microcontroller has access to the multiframe within the duration of one multiframe (5 ms).

The start of a multiframe can not be synchronized to an external signal.

2.5.3 Data Transfer between IOM[®]-2 and S₀

In the state G3 (Activated) or if the internal layer-1 statemachine is disabled and XINF of register S_CMD is programmed to '011' the B1, B2 and D bits are transferred transparently from the S/T to the IOM[®]-2 interface and vice versa. In all other states '1's are transmitted to the IOM[®]-2 interface.

Note: In intelligent NT or intelligent LT-S mode the D-channel access can be blocked by the IOM[®]-2 D-channel handler.

2.5.4 Loopback 2

C/I commands ARL and AIL close the analog loop as close to the S-interface as possible. ETSI refers to this loop under 'loopback 2'. ETSI requires, that B1, B2 and D channels have the same propagation delay when being looped back.

The D-channel Echo bit is set to bin. 0 during an analog loopback (i.e. loopback 2). The loop is transparent.

Note: After C/I-code AIL has been recognized by the S-transceiver, zeros are looped back in the B and D-channels (DU) for four frames.

2.5.5 Control of S-Transceiver / State Machine

The S-transceiver activation/ deactivation can be controlled by an internal statemachine via the IOM[®]-2 C/I-channel or by software via the μ C interface directly. In the default state the internal layer-1 statemachine of the S-transceiver is used. By setting the L1SW bit in the S_CONF0 register the internal statemachine can be disabled and the layer-1 transmit commands, which are normally generated by the internal statemachine can be written directly into the S_CMD register or the received status read out from the S_STA register, respectively. The S-transceiver layer-1 control flow is shown in [Figure 53](#).

Functional Description

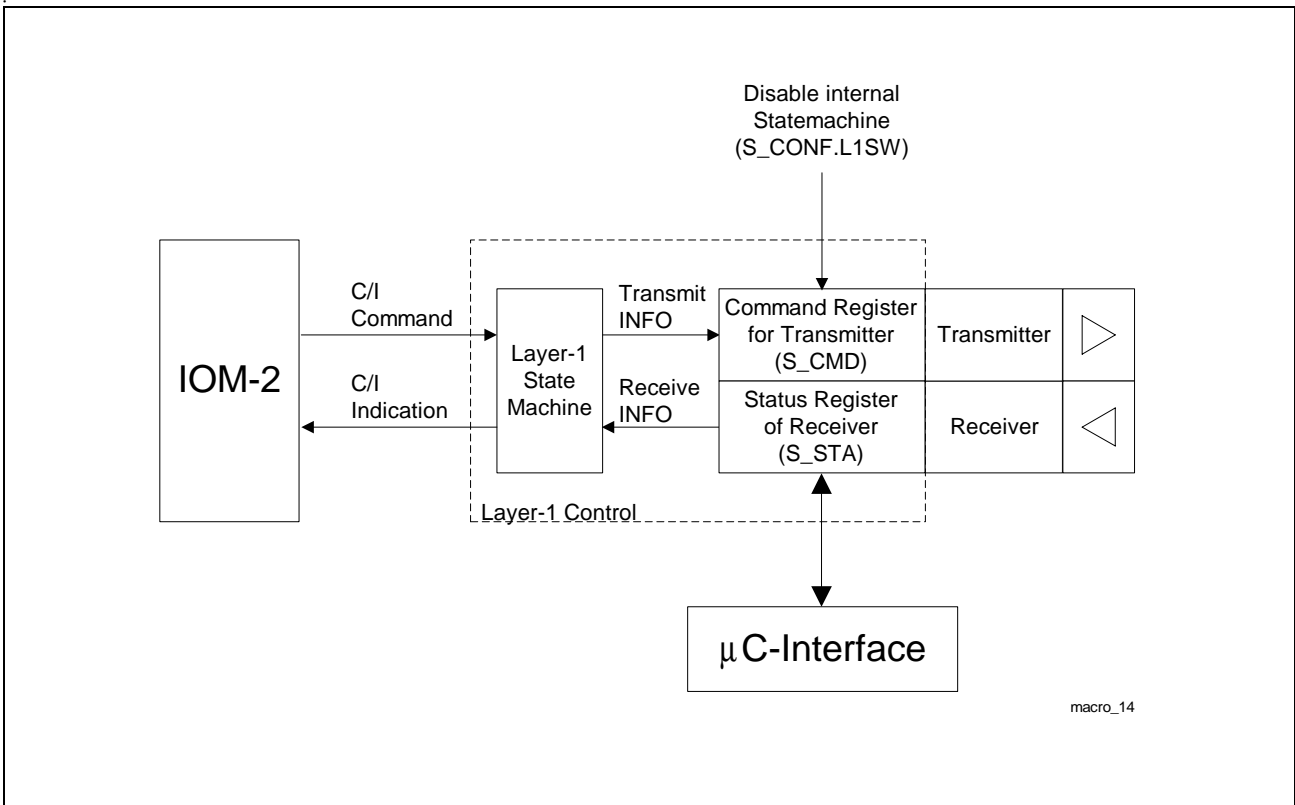

Figure 53 S-Transceiver Control

The state diagram notation is given in [Figure 54](#).

The information contained in the state diagrams are:

- state name
- Signal received from the line interface (INFO)
- Signal transmitted to the line interface (INFO)
- C/I code received (commands)
- C/I code transmitted (indications)
- transition criteria

The transition criteria are grouped into:

- C/I commands
- Signals received from the line interface (INFOs)
- Reset

Functional Description

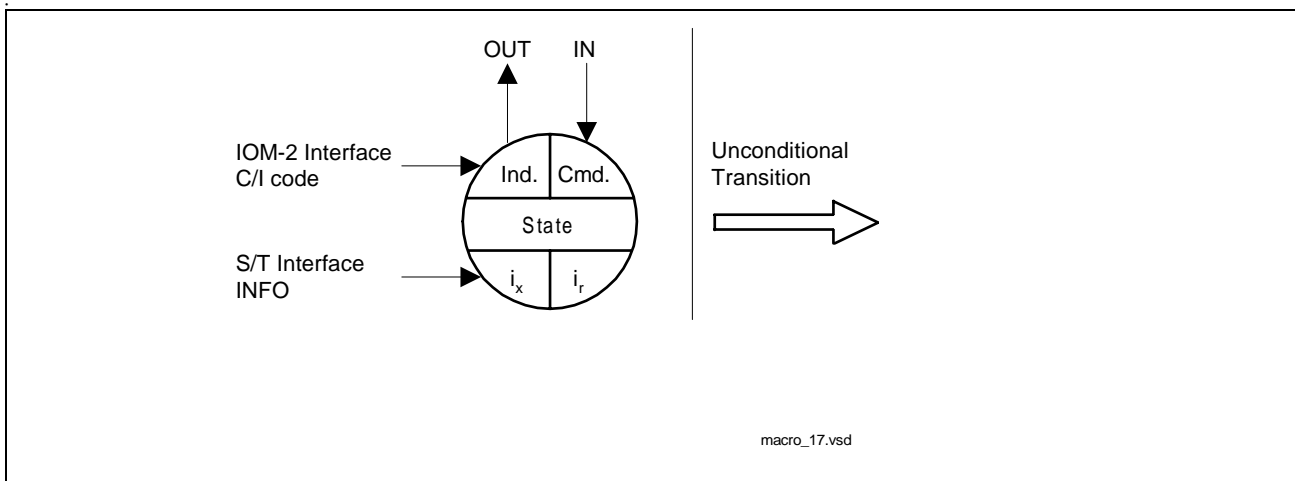

Figure 54 State Diagram Notation

As can be seen from the transition criteria, combinations of multiple conditions are possible as well. A “*” stands for a logical AND combination. And a “+” indicates a logical OR combination.

Test Signals

- 2 kHz Single Pulses (TM1)
One pulse with a width of one bit period per frame with alternating polarity.
- 96 kHz Continuous Pulses (TM2)
Continuous pulses with a pulse width of one bit period.

Note: The test signals TM1 and TM2 are invoked via C/I codes ‘TM1’ and ‘TM2’ according to [Chapter 2.5.5.1](#).

External Layer-1 State Machine

Instead of using the integrated layer-1 statemachine it is also possible to implement the layer-1 statemachine completely in software.

The internal layer-1 statemachine can be disabled by setting the L1SW bit in the S_CONF0 register to '1'.

The transmitter is completely under control of the microcontroller via register S_CMD.

The status of the receiver is stored in register S_STA and has to be evaluated by the microcontroller. This register is updated continuously. If not masked a RIC interrupt is generated by any change of the register contents. The interrupt is cleared after a read access to this register.

Reset States

After an active signal on the reset pin \overline{RST} the S-transceiver state machine is in the reset state.

Functional Description

C/I Codes in Reset State

In the reset state the C/I code 0000 (TIM) is issued. This state is entered either after a hardware reset (\overline{RST}) or with the C/I code RES.

C/I Codes in Deactivated State

If the S-transceiver is in state ‘Deactivated’ and receives $\overline{i0}$, the C/I code 0000 (TIM) is issued until expiration of the 8 ms timer. Otherwise, the C/I code 1111 (DI) is issued.

2.5.5.1 C/I Codes

The table below presents all defined C/I0 codes. A command needs to be applied continuously until the desired action has been initiated. Indications are strictly state orientated. Refer to the state diagrams in the following sections for commands and indications applicable in various states.

Code	LT-S		NT	
	Cmd	Ind	Cmd	Ind
0 0 0 0	DR	TIM	DR	TIM
0 0 0 1	RES	–	RES	–
0 0 1 0	TM1	–	TM1	–
0 0 1 1	TM2	–	TM2	–
0 1 0 0	–	RSY	RSY	RSY
0 1 0 1	–	–	–	–
0 1 1 0	–	–	–	–
0 1 1 1	–	–	–	–
1 0 0 0	AR	AR	AR	AR
1 0 0 1	–	–	–	–
1 0 1 0	ARL	–	ARL	–
1 0 1 1	–	CVR	–	CVR
1 1 0 0	–	AI	AI	AI
1 1 0 1	–	–	–	–
1 1 1 0	–	–	AIL	–
1 1 1 1	DC	DI	DC	DI

Functional Description**Receive Infos on S/T**

I0	INFO 0 detected
$\bar{I}0$	Level detected (signal different to I0)
I3	INFO 3 detected
$\bar{I}3$	Any INFO other than INFO 3

Transmit Infos on S/T

I0	INFO 0
I2	INFO 2
I4	INFO 4
It	Send Single Pulses (TM1). Send Continuous Pulses (TM2).

Functional Description

2.5.5.2 State Machine NT Mode

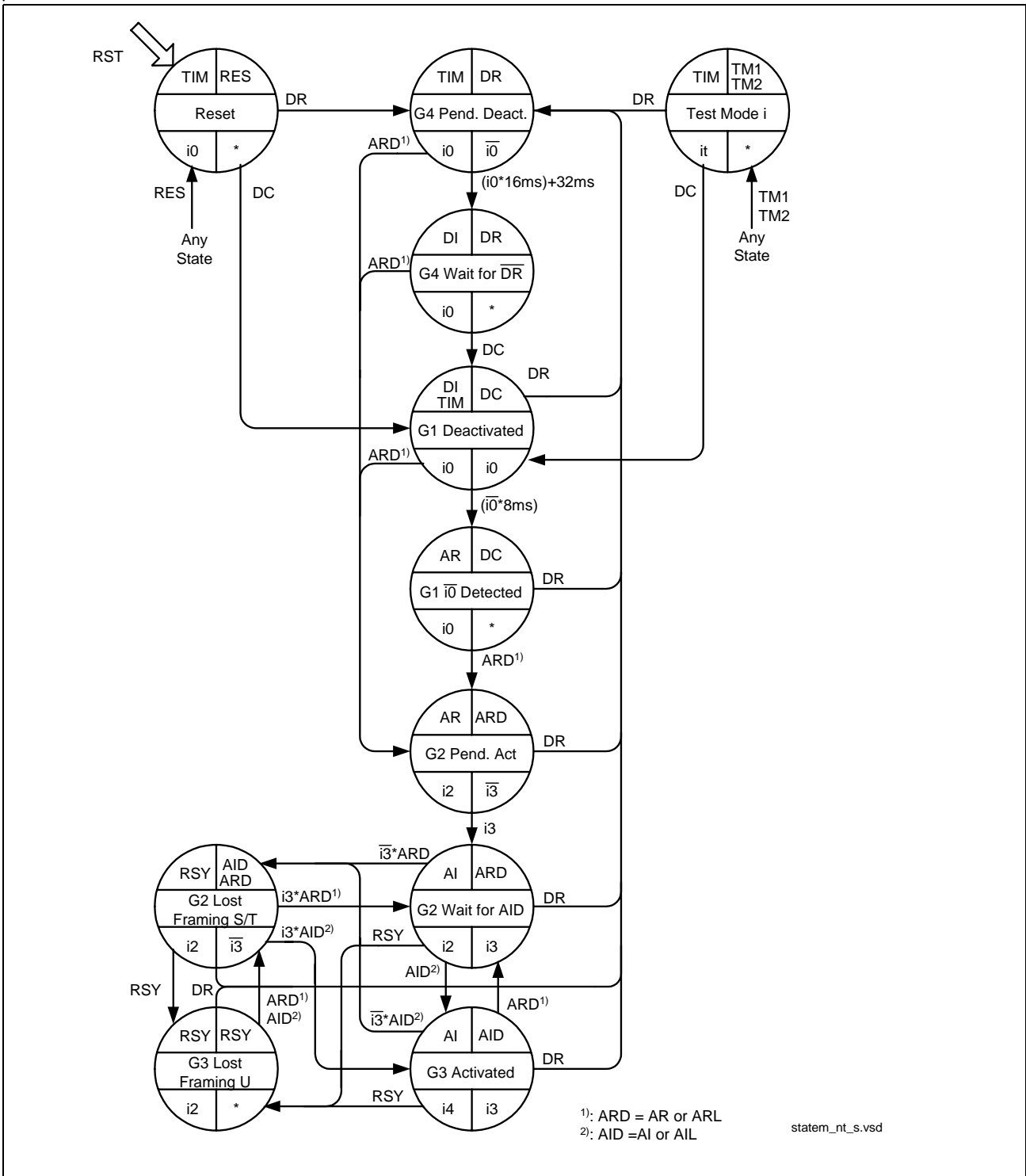

Figure 55 State Machine NT Mode

Note: State 'Test Mode' can be entered from any state except from state 'Test Mode' itself, i.e. C/I-code 'TMI' must not be followed by C/I-code 'TMj' directly.

Functional Description

G1 Deactivated

The S-transceiver is not transmitting. There is no signal detected on the S/T-interface, and no activation command is received in the C/I channel. Activation is possible from the S/T interface and from the IOM[®]-2 interface.

G1 $\overline{\text{IO}}$ Detected

An $\overline{\text{INFO 0}}$ is detected on the S/T-interface, translated to an "Activation Request" indication in the C/I channel. The S-transceiver is waiting for an AR command, which normally indicates that the transmission line upstream is synchronized.

G2 Pending Activation

As a result of the ARD command, an INFO 2 is sent on the S/T-interface. INFO 3 is not yet received. In case of ARL command, loop 2 is closed.

G2 wait for AID

INFO 3 was received, INFO 2 continues to be transmitted while the S-transceiver waits for a "switch-through" command AID from the device upstream.

G3 Activated

INFO 4 is sent on the S/T-interface as a result of the "switch through" command AID: the B and D-channels are transparent. On the command AIL, loop 2 is closed.

G2 Lost Framing S/T

This state is reached when the transceiver has lost synchronism in the state G3 activated.

G3 Lost Framing U

On receiving an RSY command which usually indicates that synchronization has been lost on the transmission line, the S-transceiver transmits INFO 2.

G4 Pending Deactivation

This state is triggered by a deactivation request DR, and is an unstable state. Indication DI (state "G4 wait for DR") is issued by the transceiver when:

either INFO0 is received for a duration of 16 ms
or an internal timer of 32 ms expires.

Functional Description

G4 wait for \overline{DR}

Final state after a deactivation request. The S-transceiver remains in this state until DC is issued.

Unconditional States

Test Mode TM1

Send Single Pulses

Test Mode TM2

Send Continuous Pulses

C/I Commands

Command	Abbr.	Code	Remark
Deactivation Request	DR	0000	Deactivation Request. Initiates a complete deactivation by transmitting INFO 0.
Reset	RES	0001	Reset of state machine. Transmission of Info0. No reaction to incoming infos. RES is an unconditional command.
Send Single Pulses	TM1	0010	Send Single Pulses.
Send Continuous Pulses	TM2	0011	Send Continuous Pulses.
Receiver not Synchronous	RSY	0100	Receiver is not synchronous
Activation Request	AR	1000	Activation Request. This command is used to start an activation.
Activation Request Loop	ARL	1010	Activation request loop. The transceiver is requested to operate an analog loop-back close to the S/T-interface.
Activation Indication	AI	1100	Activation Indication. Synchronous receiver, i.e. activation completed.

Functional Description

Command	Abbr.	Code	Remark
Activation Indication Loop	AIL	1110	Activation Indication Loop
Deactivation Confirmation	DC	1111	Deactivation Confirmation. Transfers the transceiver into a deactivated state in which it can be activated from a terminal (detection of $\overline{\text{INFO 0}}$ enabled).

Indication	Abbr.	Code	Remark
Timing	TIM	0000	Interim indication during deactivation procedure.
Receiver not Synchronous	RSY	0100	Receiver is not synchronous.
Activation Request	AR	1000	$\overline{\text{INFO 0}}$ received from terminal. Activation proceeds.
Illegal Code Violation	CVR	1011	Illegal code violation received. This function has to be enabled in S_CONF0.EN_ICV.
Activation Indication	AI	1100	Synchronous receiver, i.e. activation completed.
Deactivation Indication	DI	1111	Timer (32 ms) expired or $\overline{\text{INFO 0}}$ received for a duration of 16 ms after deactivation request.

Functional Description

2.5.5.3 State Machine LT-S Mode

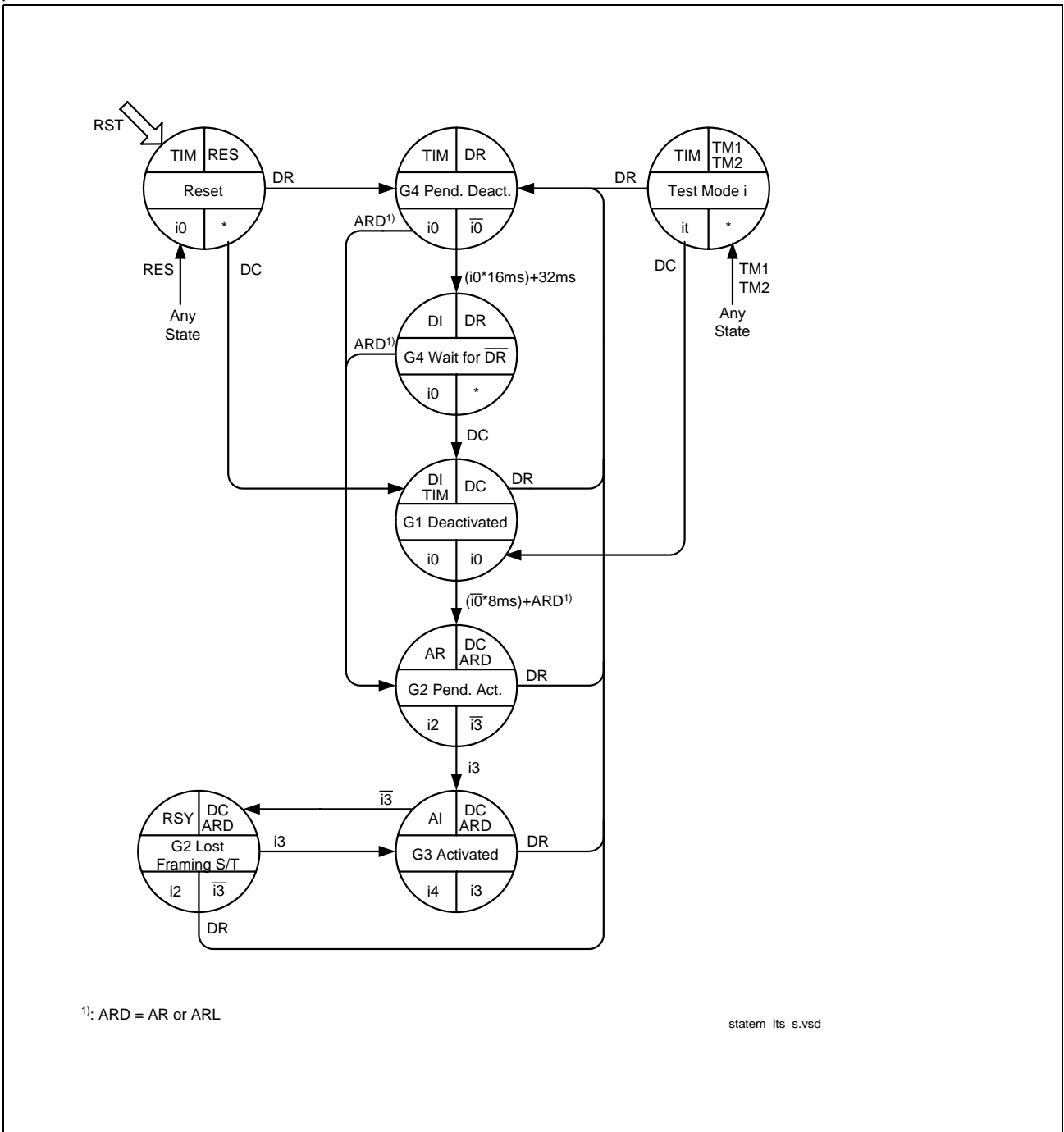

Figure 56 State Machine LT-S Mode

Note: State 'Test Mode' can be entered from any state except from state 'Test Mode' itself, i.e. C/I-code 'TMi' must not be followed by C/I-code 'TMj' directly.

Functional Description

G1 deactivated

The S-transceiver is not transmitting. There is no signal detected on the S/T-interface, and no activation command is received in the C/I channel. Activation is possible from the S/T interface and from the IOM[®]-2 interface.

G2 pending activation

As a result of an $\overline{\text{INFO 0}}$ detected on the S/T line or an ARD command, the S-transceiver begins transmitting INFO 2 and waits for reception of INFO 3. The timer to supervise reception of INFO 3 is to be implemented in software. In case of an ARL command, loop 2 is closed.

G3 activated

Normal state where INFO 4 is transmitted to the S/T-interface. The transceiver remains in this state as long as neither a deactivation nor a test mode is requested, nor the receiver loses synchronism.

When receiver synchronism is lost, INFO 2 is sent automatically. After reception of INFO 3, the transmitter keeps on sending INFO 4.

G2 lost framing

This state is reached when the S-transceiver has lost synchronism in the state G3 activated.

G4 pending deactivation

This state is triggered by a deactivation request DR. It is an unstable state: indication DI (state "G4 wait for DR.") is issued by the S-transceiver when:

either INFO0 is received for a duration of 16 ms,
or an internal timer of 32 ms expires.

G4 wait for $\overline{\text{DR}}$

Final state after a deactivation request. The transceiver remains in this state until DC is issued.

Unconditional States

Test mode - TM1

Single alternating pulses are sent on the S/T-interface.

Functional Description
Test mode - TM2

Continuous alternating pulses are sent on the S/T-interface.

Command	Abbr.	Code	Remark
Deactivation Request	DR	0000	DR - Deactivation Request. Initiates a complete deactivation by transmitting INFO 0.
Reset	RES	0001	Reset of state machine. Transmission of Info0. No reaction to incoming infos. RES is an unconditional command.
Send Single Pulses	TM1	0010	Send Single Pulses.
Send Continuous Pulses	TM2	0011	Send Continuous Pulses.
Activation Request	AR	1000	Activation Request. This command is used to start an activation.
Activation Request Loop	ARL	1010	Activation request loop. The transceiver is requested to operate an analog loop-back close to the S/T-interface.
Deactivation Confirmation	DC	1111	Deactivation Confirmation. Transfers the transceiver into a deactivated state in which it can be activated from a terminal (detection of $\overline{\text{INFO 0}}$ enabled).

Indication	Abbr.	Code	Remark
Timing	TIM	0000	Interim indication during activation procedure in G1.
Receiver not Synchronous	RSY	0100	Receiver is not synchronous
Activation Request	AR	1000	$\overline{\text{INFO 0}}$ received from terminal. Activation proceeds.
Illegal Code Violation	CVR	1011	Illegal code violation received. This function has to be enabled in S_CONF0.EN_ICV.
Activation Indication	AI	1100	Synchronous receiver, i.e. activation completed.
Deactivation Indication	DI	1111	Timer (32 ms) expired or INFO 0 received for a duration of 16 ms after deactivation request

Functional Description

2.5.6 S-Transceiver Enable / Disable

The layer-1 part of the S-transceiver can be enabled/disabled with the two bits S_CONF0.DIS_TR and S_CONF2.DIS_TX.

If DIS_TX='1' the transmit buffers are disabled. The receiver will monitor for incoming data in this configuration. By default the transmitter is disabled (DIS_TX = '1').

If the transceiver is disabled (DIS_TR = '1', DIS_TX = don't care) all layer-1 functions are disabled including the level detection circuit of the receiver. In this case the power consumption of the S-transceiver is reduced to a minimum.

2.5.7 Interrupt Structure S-Transceiver

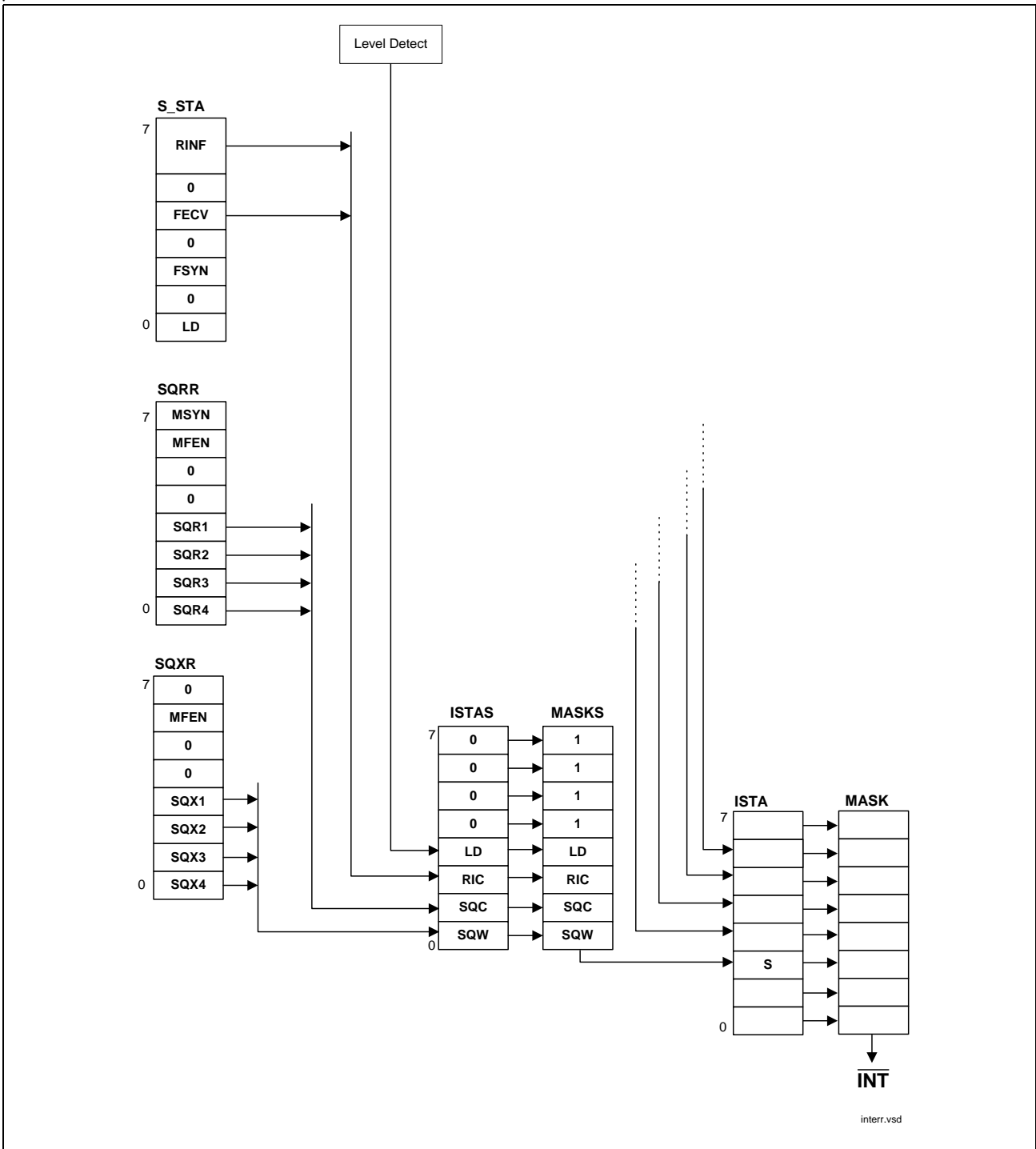

Figure 57 Interrupt Structure S-Transceiver

Operational Description

3 Operational Description

3.1 Layer 1 Activation/Deactivation

3.1.1 Complete Activation Initiated by Exchange

Figure 58 depicts the procedure if activation has been initiated by the exchange side (LT).

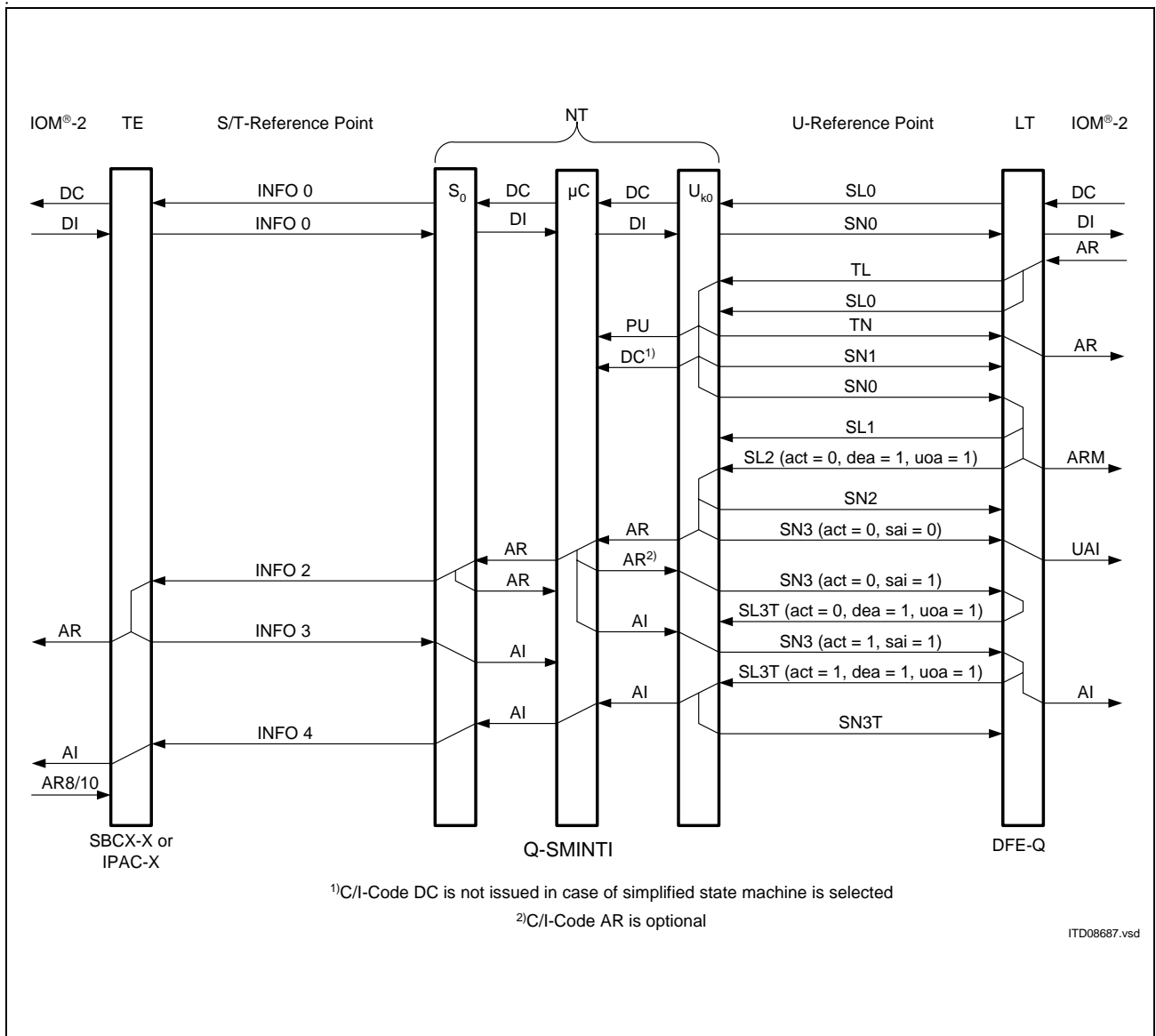

Figure 58 Complete Activation Initiated by Exchange

Operational Description

3.1.2 Complete Activation Initiated by TE

Figure 59 depicts the procedure if activation has been initiated by the terminal side (TE).

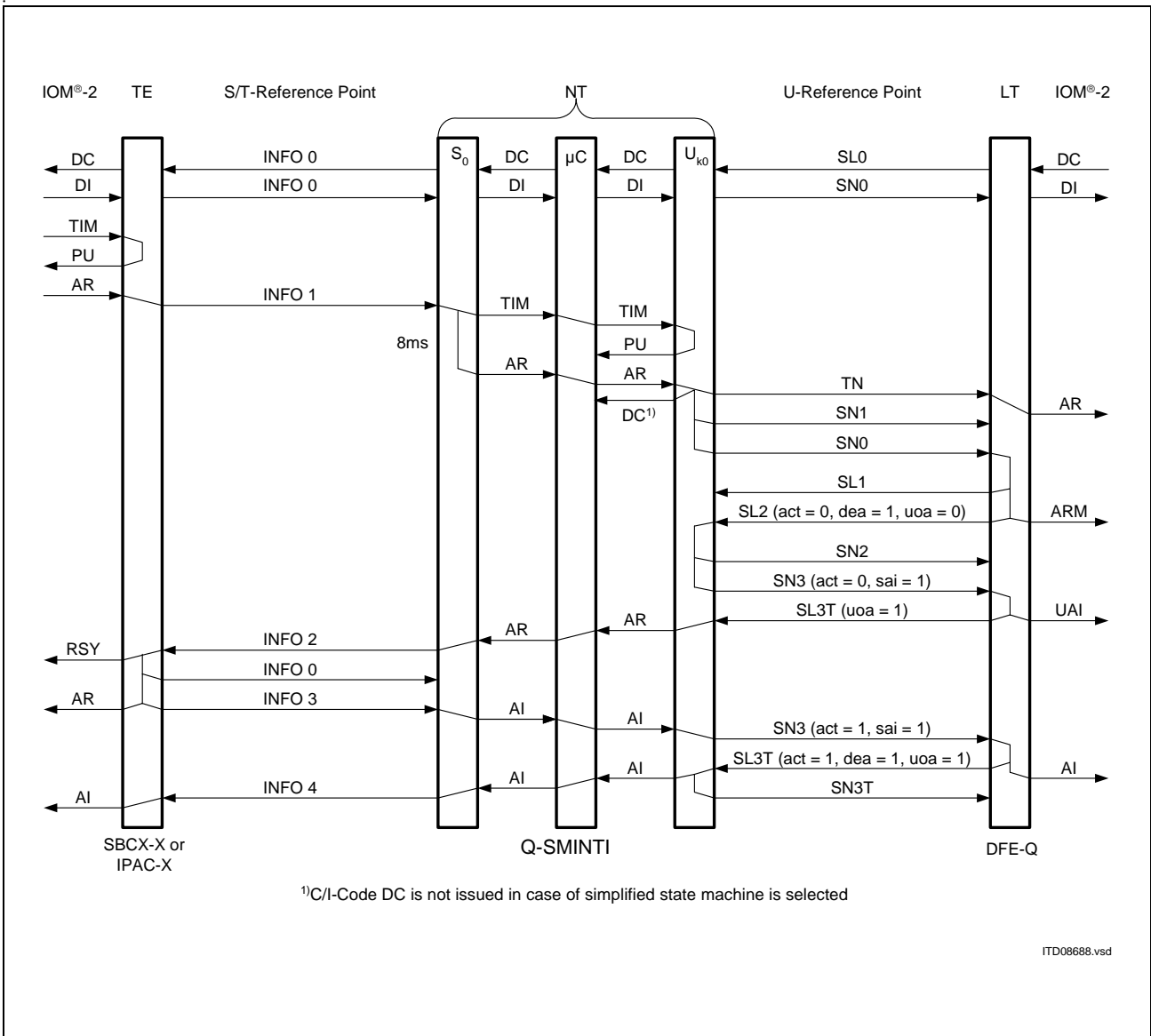

Figure 59 Complete Activation Initiated by TE

Operational Description

3.1.3 Complete Activation Initiated by NT

Figure 60 depicts the procedure if activation has been initiated by the Q-SMINT[®]I itself (e.g. after hook-off of a local analog phone).

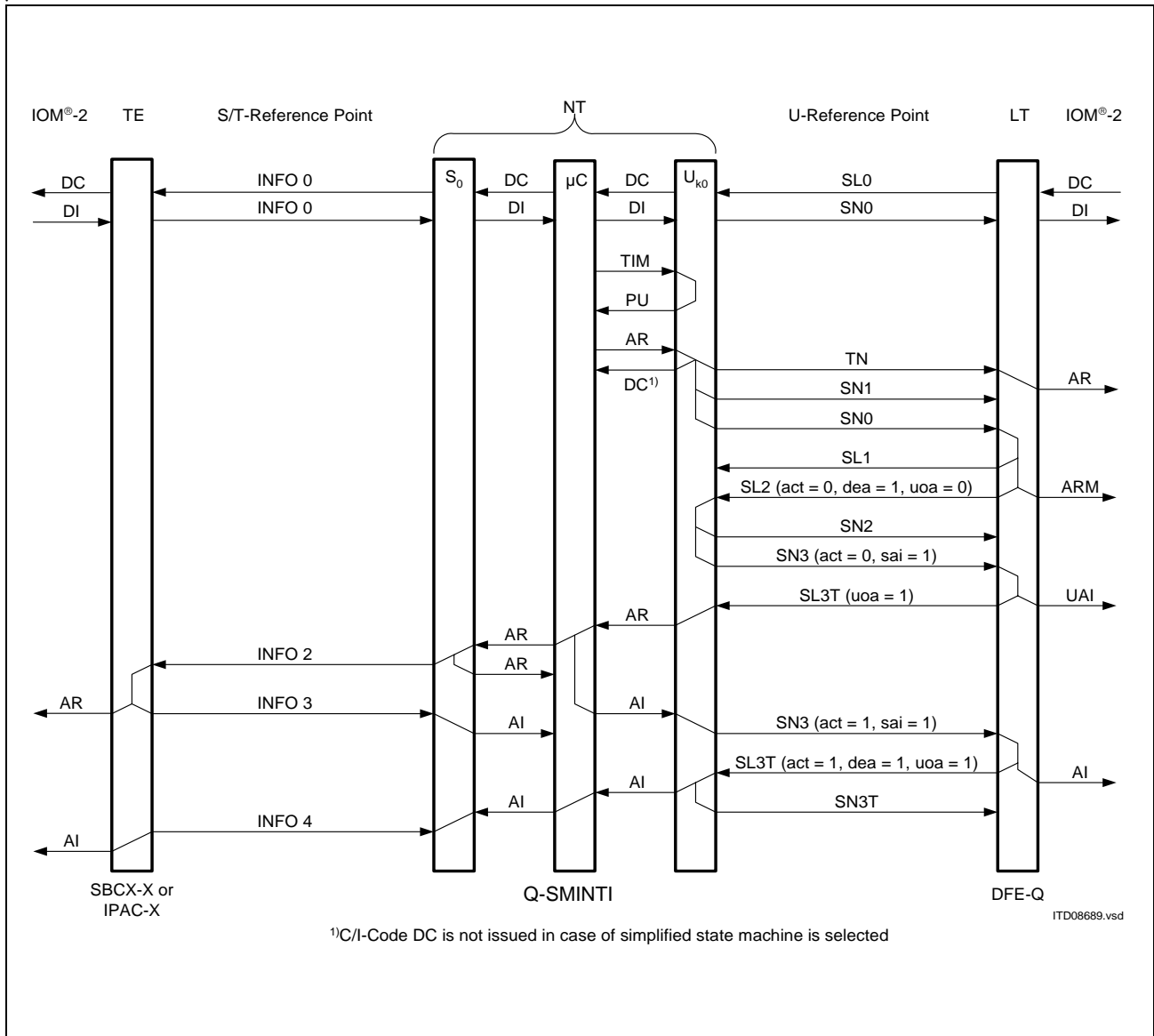

Figure 60 Complete Activation Initiated by Q-SMINT[®]I

Operational Description

3.1.4 Complete Deactivation

Figure 61 depicts the procedure if deactivation has been initiated. Deactivation of layer 1 is always initiated by the exchange.

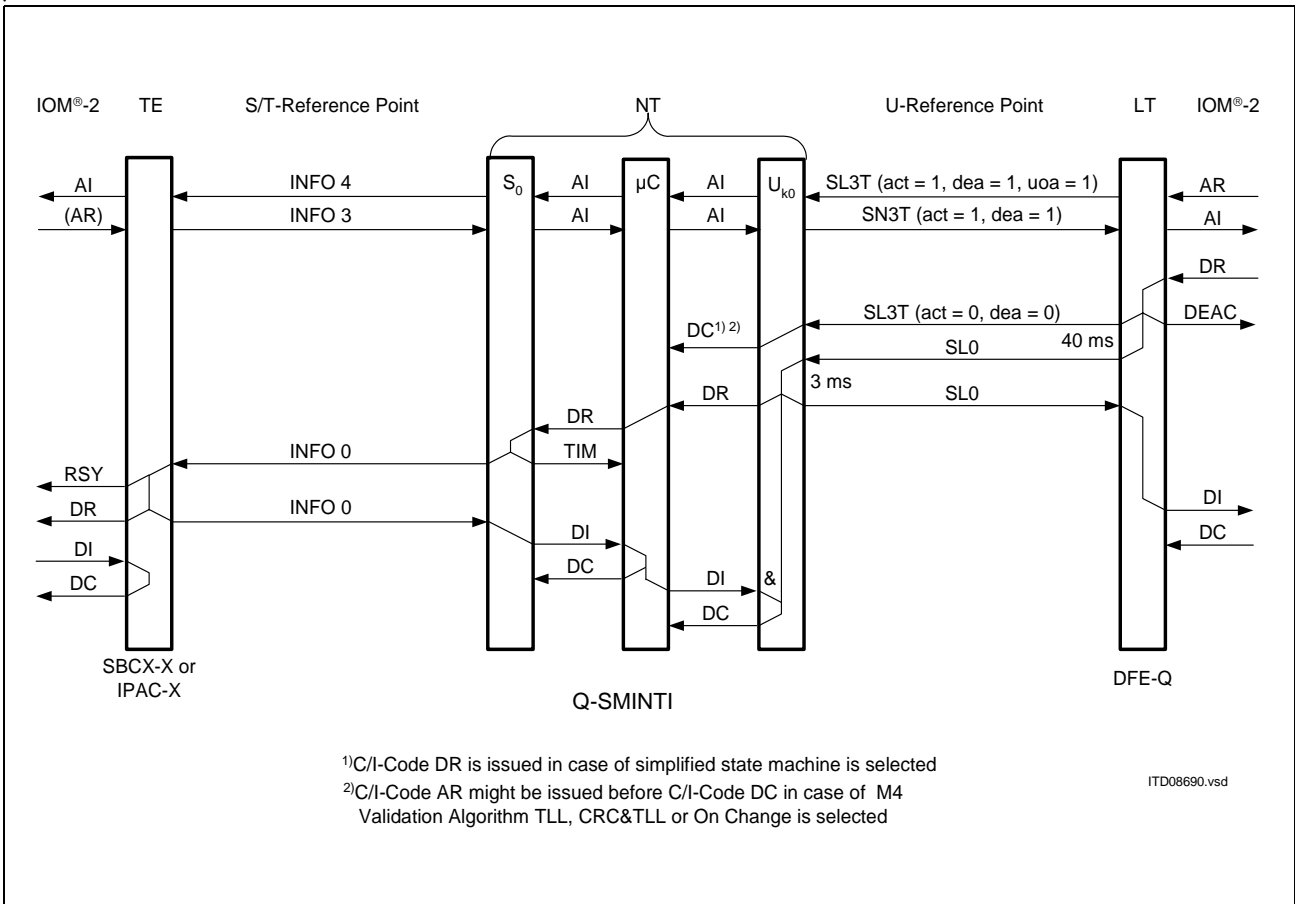

Figure 61 Complete Deactivation Initiated by Exchange

Operational Description

3.1.5 Loop 2

Figure 62 depicts the procedure if loop 2 is closed and opened.

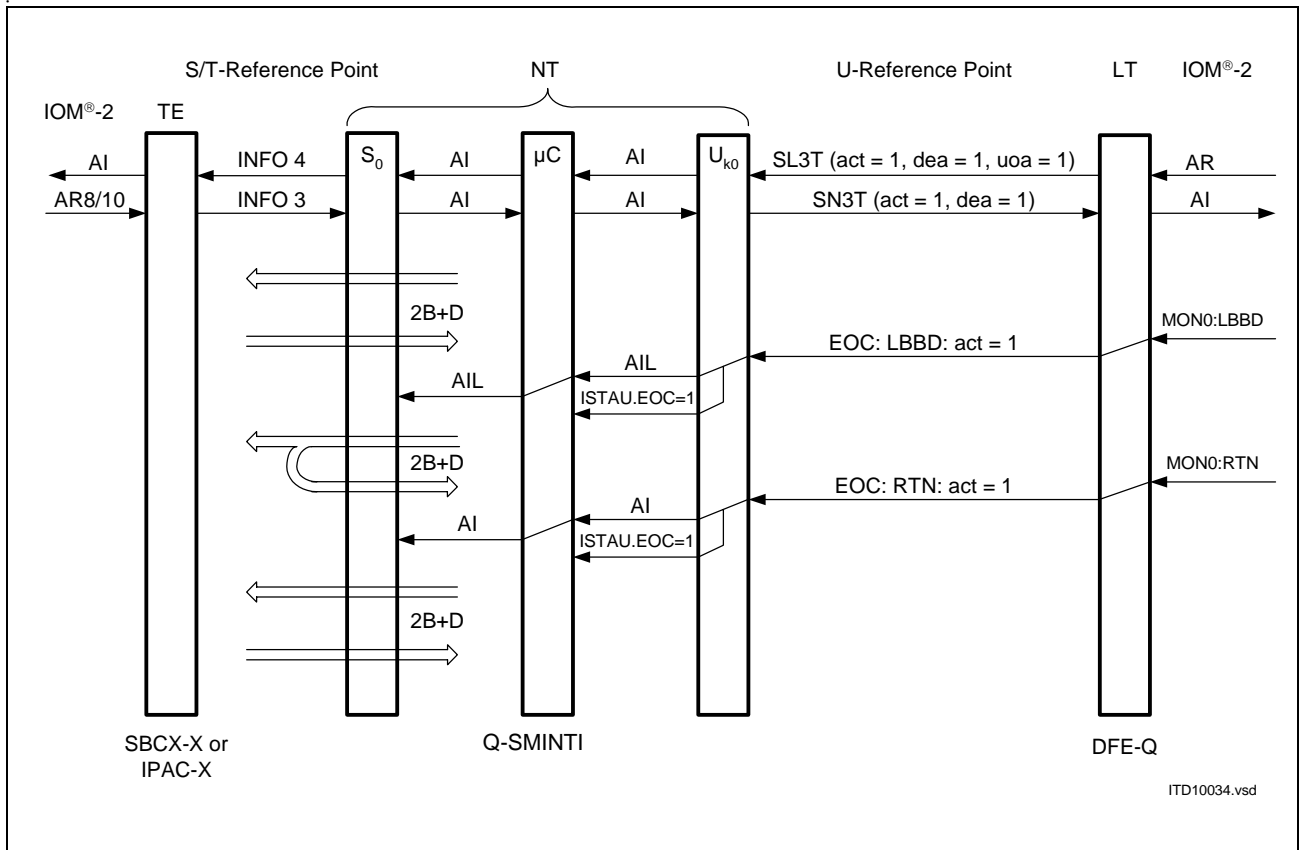

Figure 62 Loop 2

Operational Description

3.2 Layer 1 Loopbacks

Test loopbacks are specified by the national PTTs in order to facilitate the location of defect systems. Four different loopbacks are defined. The position of each loopback is illustrated in **Figure 63**.

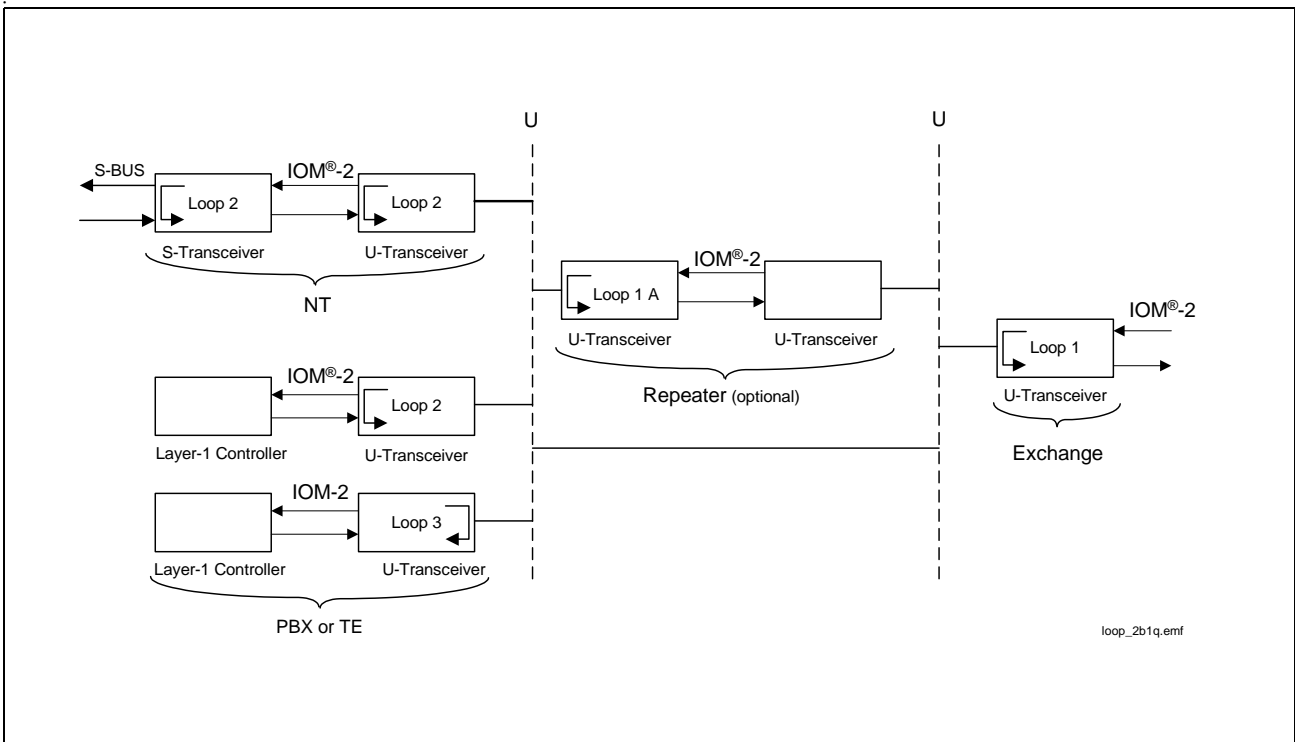

Figure 63 Test Loopbacks

Loopbacks #1, #1A and #2 are controlled by the exchange. Loopback #3 is controlled locally on the remote side. All four loopback types are transparent. This means all bits that are looped back will also be passed onwards in the normal manner. Only the data looped back internally is processed; signals on the receive pins are ignored. The propagation delay of actually looped B and D channels data must be identical in all loopbacks.

Besides the remote controlled loopback stimulation via the EOC channel, the Q-SMINT[®]I features also direct loopback control via its register set.

3.2.1 Analog Loopback U-Transceiver (No. 3)

Loopback #3 is closed by the U-transceiver as near to the U-interface as possible, i.e. the loop is closed in the analog part by short circuiting the output to the input. The signal on the line is ignored in this state. For this reason it is also called analog loopback. All analog signals will still be passed on to the U-interface.

Before an analog loopback is closed by the appropriate C/I-command ARL (activation request loopback 3), the U-transceiver shall have been reset.

Operational Description

In order to open an analog loopback correctly, force the U-transceiver into the RESET state. This ensures that the echo coefficients and equalizer coefficients will converge correctly when activating anew.

3.2.2 Analog Loop-Back S-Transceiver

The Q-SMINT[®]I provides test and diagnostic functions for the S/T interface:

The **internal local loop** (internal Loop A) is activated by a C/I command ARL or by setting the bit LP_A (Loop Analog) in the S_CMD register if the layer-1 statemachine is disabled.

The transmit data of the transmitter is looped back internally to the receiver. The data of the IOM[®]-2 input B- and D-channels are looped back to the output B- and D-channels. The S/T interface level detector is enabled, i.e. if a level is detected this will be reported by the Resynchronization Indication (RSY) but the loop function is not affected. Depending on the DIS_TX bit in the S_CONF2 register the internal local loop can be transparent or non transparent to the S/T line.

The **external local loop (external Loop A)** is activated in the same way as the internal local loop described above. Additionally the EXLP bit in the S_CONF0 register has to be programmed and the loop has to be closed externally as described in [Figure 64](#). The S/T interface level detector is disabled.

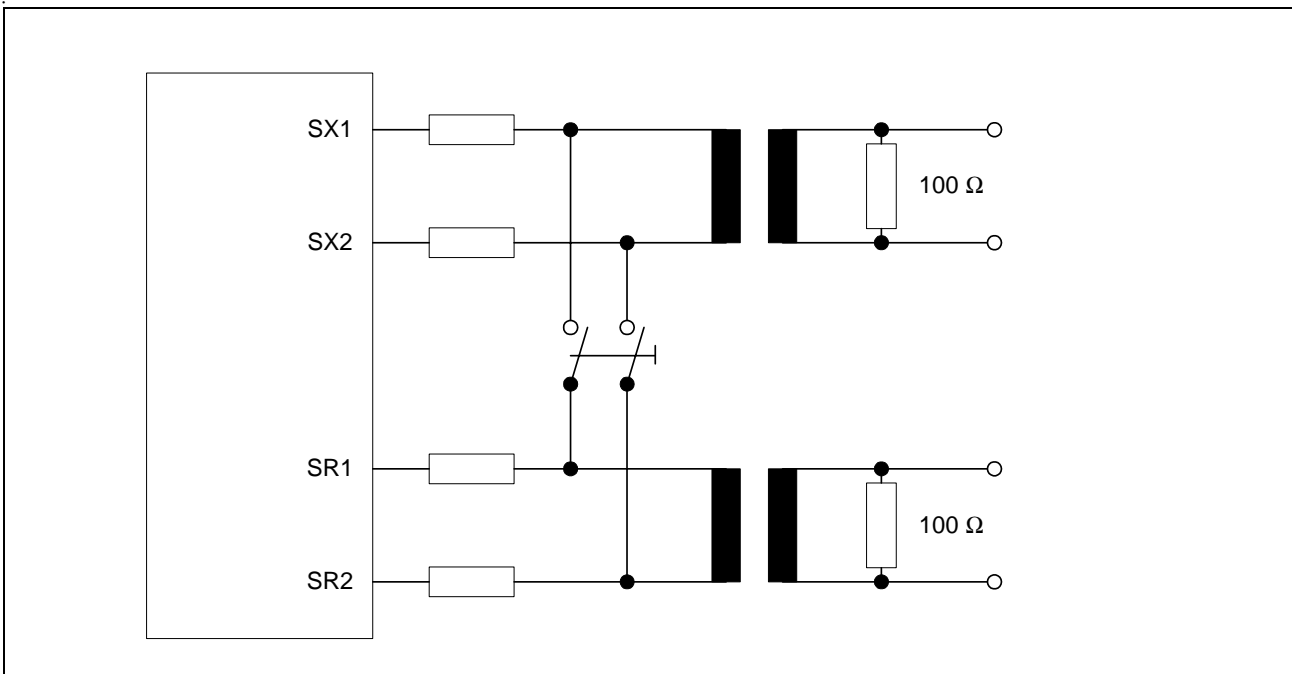

Figure 64 External Loop at the S/T-Interface

Operational Description

3.2.3 Loopback No.2

For loopback #2 several alternatives exist. Both the type of loopback and the location may vary. The following loopback types belong to the loopback-#2 category:

- complete loopback (B1,B2,D), in the U-transceiver
- complete loopback (B1,B2,D), in a downstream device
- B1-channel loopback, always performed in the U-transceiver
- B2-channel loopback, always performed in the U-transceiver

All loop variations performed by the U-transceiver are closed as near to the internal IOM[®]-2 interface as possible.

Normally loopback #2 is controlled by the exchange. The maintenance channel is used for this purpose. All loopback functions are latched. This allows channel B1 and channel B2 to be looped back simultaneously.

3.2.3.1 Complete Loopback

When receiving the request for a complete loopback, the U transceiver passes it on to the downstream device, e.g. the S-bus transceiver. This is achieved by issuing the C/I-code AIL in the “Transparent” state or C/I = ARL in states different than “Transparent” (note: this holds true only for the EOC automode). The U transceiver may be commanded to close the complete loopback itself.

Figure 65 illustrates the two options.

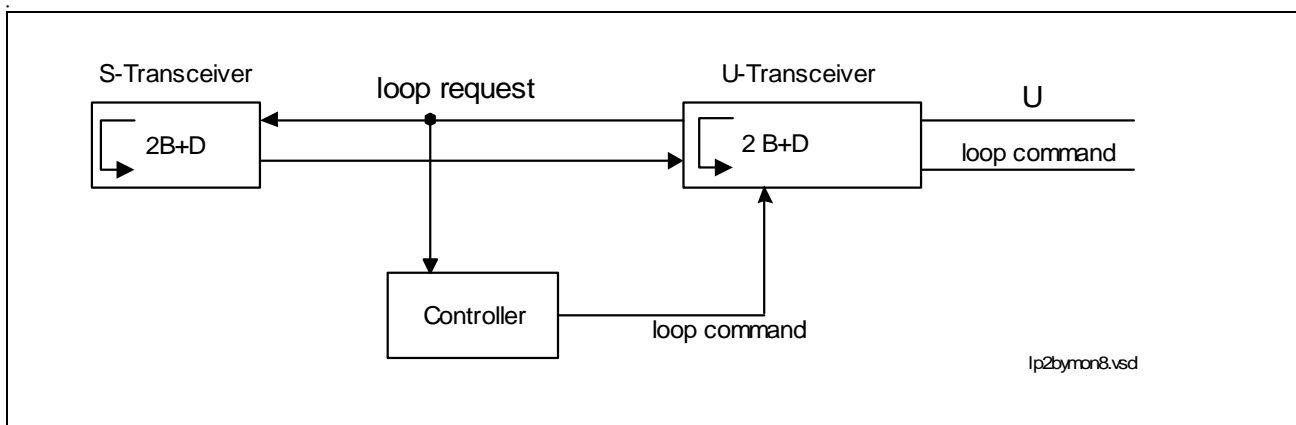

Figure 65 Complete Loopback Options in NT-Mode

The complete loopback is either opened under control of the exchange via the maintenance channel or locally controlled via the μ C. No reset is required for loopback #2. The line stays active and is ready for data transmission.

Operational Description

3.2.3.2 Loopback No.2 - Single Channel Loopbacks

Single channel loopbacks are always performed directly in the U-Transceiver. No difference between the B1-channel and the B2-channel loopback control procedure exists.

3.2.4 Local Loopbacks Featured By the LOOP Register

Besides the standardized remote loopbacks the U-transceiver features additional local loopbacks for enhanced test and debugging facilities. The local loopbacks that are featured by register LOOP are shown in [Figure 66](#). They are closed in the U-transceiver itself and can be activated regardless of the current operational status.

By the LOOP register it can be configured whether the loopback is closed only for the B1 and/or B2 or for 2B+D channels and whether the loopback is closed towards the internal IOM[®]-2 interface or towards the U-Interface.

By default the loopbacks are set to transparent mode. In transparent mode the data is both passed on and looped back. In non-transparent mode the data is not forwarded but substituted by 1s (idle code).

Besides the loopbacks in the system interface an additional digital loopback (DLB), the Framer/ Deframer loopback, is featured. It allows to test most digital functions of the U-transceiver besides the signal processing blocks.

Operational Description

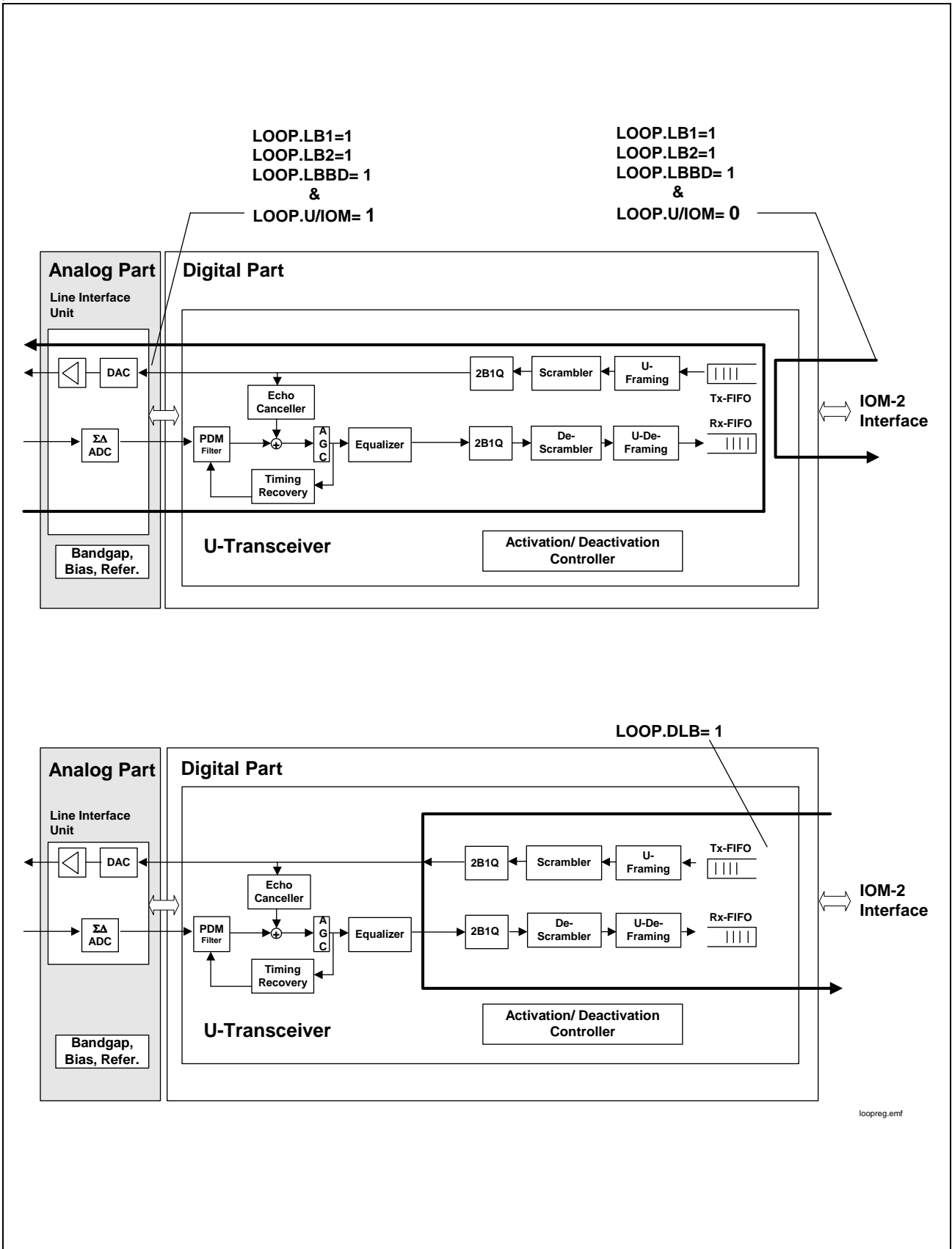

loopreg.emf

Figure 66 Loopbacks Featured by Register LOOP

3.3 External Circuitry

3.3.1 Power Supply Blocking Recommendation

The following blocking circuitry is suggested.

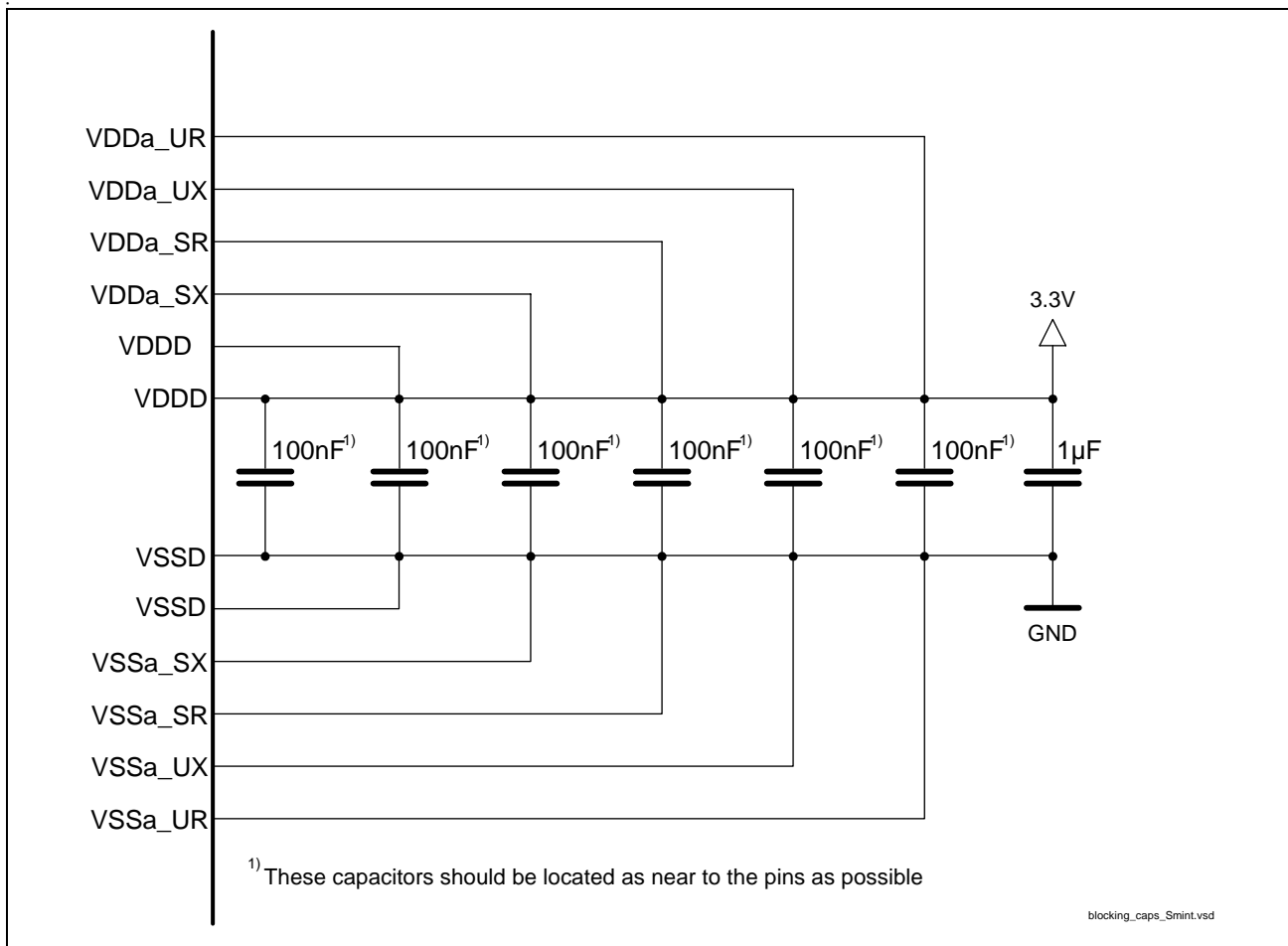

Figure 67 Power Supply Blocking

3.3.2 U-Transceiver

The Q-SMINT[®]I is connected to the twisted pair via a transformer. **Figure 68** shows the recommended external circuitry. The recommended protection circuitry is not displayed.

Note: The integrated hybrid as specified for Version 1.1 is no more available in Version 1.3 and an external hybrid is required.

Operational Description

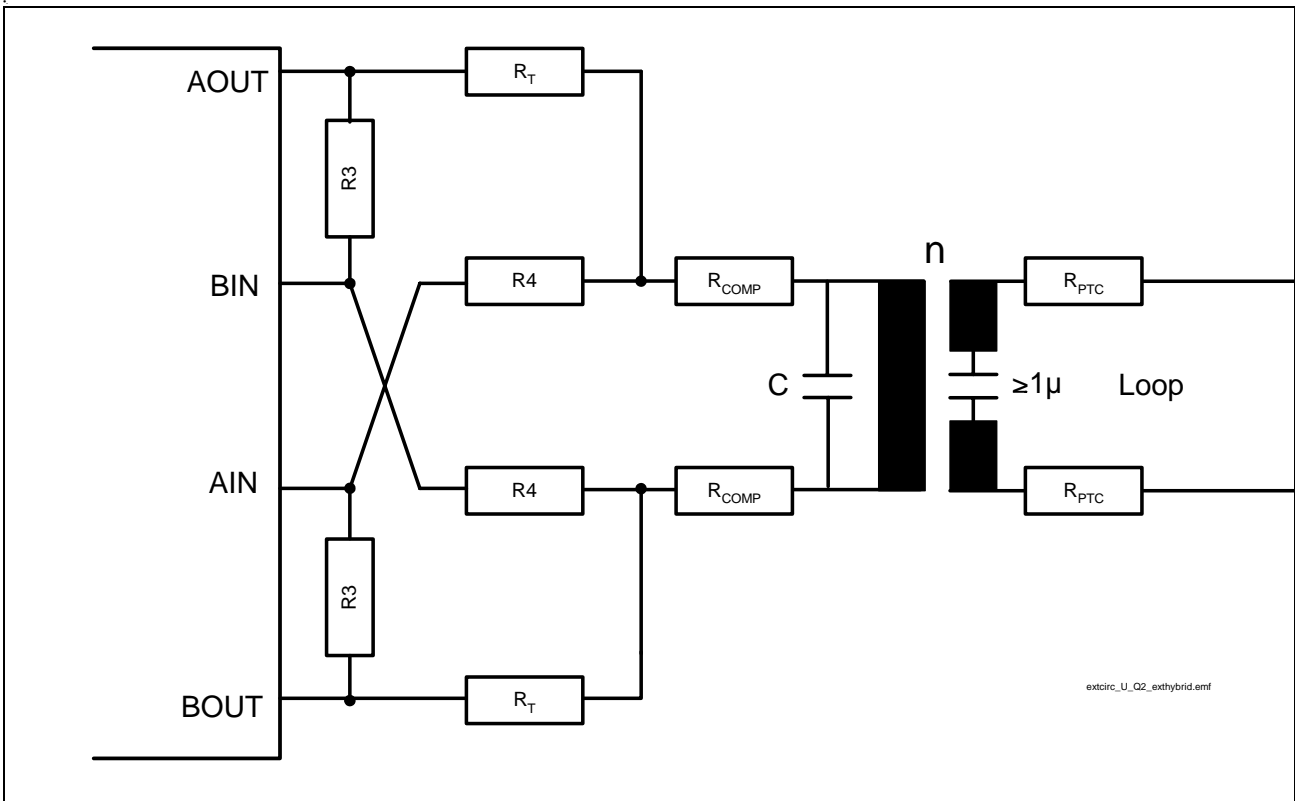

Figure 68 External Circuitry U-Transceiver

U-Transformer Parameters

The following Table 31 lists parameters of typical U-transformers:

Table 31 U-Transformer Parameters

U-Transformer Parameters	Symbol	Value	Unit
U-Transformer ratio; Device side : Line side	n	1 : 2	
Main inductance of windings on the line side	L_H	14.5	mH
Leakage inductance of windings on the line side	L_S	<75	μ H
Coupling capacitance between the windings on the device side and the windings on the line side	C_K	100	pF
DC resistance of the windings on device side	R_B	2.5 ¹⁾	Ω
DC resistance of the windings on line side	R_L	5 ¹⁾	Ω

¹⁾ R_B / R_L according to equation[2]

Operational Description

Resistors of the External Hybrid R3, R4 and R_T

R3 = 1.3 kΩ

R4 = 1.0 kΩ

R_T = 9.5 Ω

Resistors on the Line Side R_{P_{TC}} / Chip Side R_T

Optional use of up to 2x20 Ω resistors (2xR_{P_{TC}}) on the line side of the transformer requires compensation resistors R_{COMP} depending on R_{P_{TC}}:

$$2R_{PTC} + 8R_{COMP} = 40 \Omega \tag{1}$$

$$2R_{PTC} + 4(2R_{COMP} + 2R_T + R_{OUT} + R_B) + R_L = 135 \Omega \tag{2}$$

R_B, R_L : see [Table 31](#)

R_{OUT} : see [Table 38](#)

27 nF Capacitor C

To achieve optimum performance the 27 nF capacitor should be MKT. A Ceramic capacitor is not recommended.

Tolerances

- Rs: ±1%
- C=27 nF: ±10-20%
- L=14.5 mH: ±10%

3.3.3 S-Transceiver

In order to comply to the physical requirements of ITU recommendation I.430 and considering the national requirements concerning overvoltage protection and electromagnetic compatibility (EMC), the S-transceiver needs some additional circuitry.

S-Transformer Parameters

The following [Table 32](#) lists parameters of a typical S-transformer:

Table 32 S-Transformer Parameters

Transformer Parameters	Symbol	Value	Unit
Transformer ratio; Device side : Line side	n	2 : 1	
Main inductance of windings on the line side	L _H	typ. 30	mH
Leakage inductance of windings on the line side	L _S	typ. <3	μH

Operational Description

Transformer Parameters	Symbol	Value	Unit
Coupling capacitance between the windings on the device side and the windings on the line side	C_K	typ. <100	pF
DC resistance of the windings on device side	R_B	typ. 2.4	Ω
DC resistance of the windings on line side	R_L	typ. 1.4	Ω

Transmitter

The **transmitter** requires external resistors $R_{stx} = 47\Omega$ in order to adjust the output voltage to the pulse mask (nominal 750 mV according to ITU I.430, to be tested with the test mode "TM1") on the one hand and in order to meet the output impedance of minimum 20 Ω on the other hand (to be tested with the testmode 'Continuous Pulses') on the other hand.

Note: The resistance of the S-transformer must be taken into account when dimensioning the external resistors R_{stx} . If the transmit path contains additional components (e.g. a choke), then the resistance of these additional components must be taken into account, too.

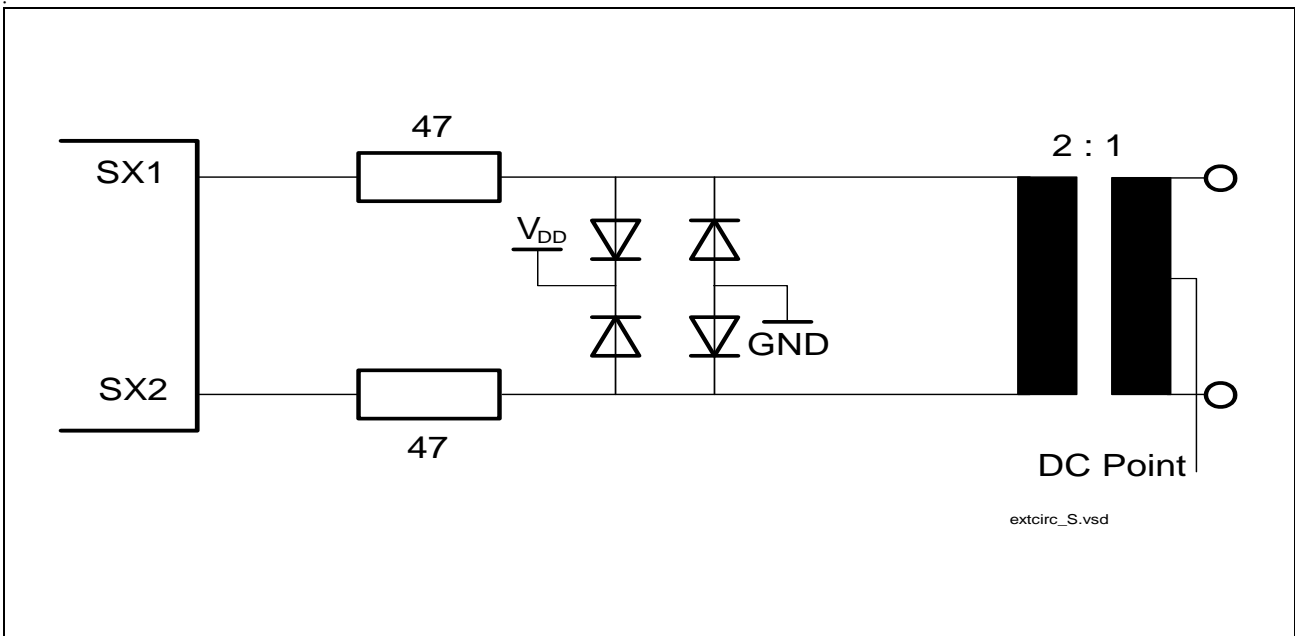

Figure 69 External Circuitry S-Interface Transmitter

Operational Description

Receiver

The **receiver** of the S-transceiver is symmetrical. 10 kΩ overall resistance are recommended in each receive path. It is preferable to split the resistance into two resistors for each line. This allows to place a high resistance between the transformer and the diode protection circuit (required to pass 96 kHz input impedance test of ITU I.430 [8] and ETS 300012-1). The remaining resistance (1.8 kΩ) protects the S-transceiver itself from input current peaks.

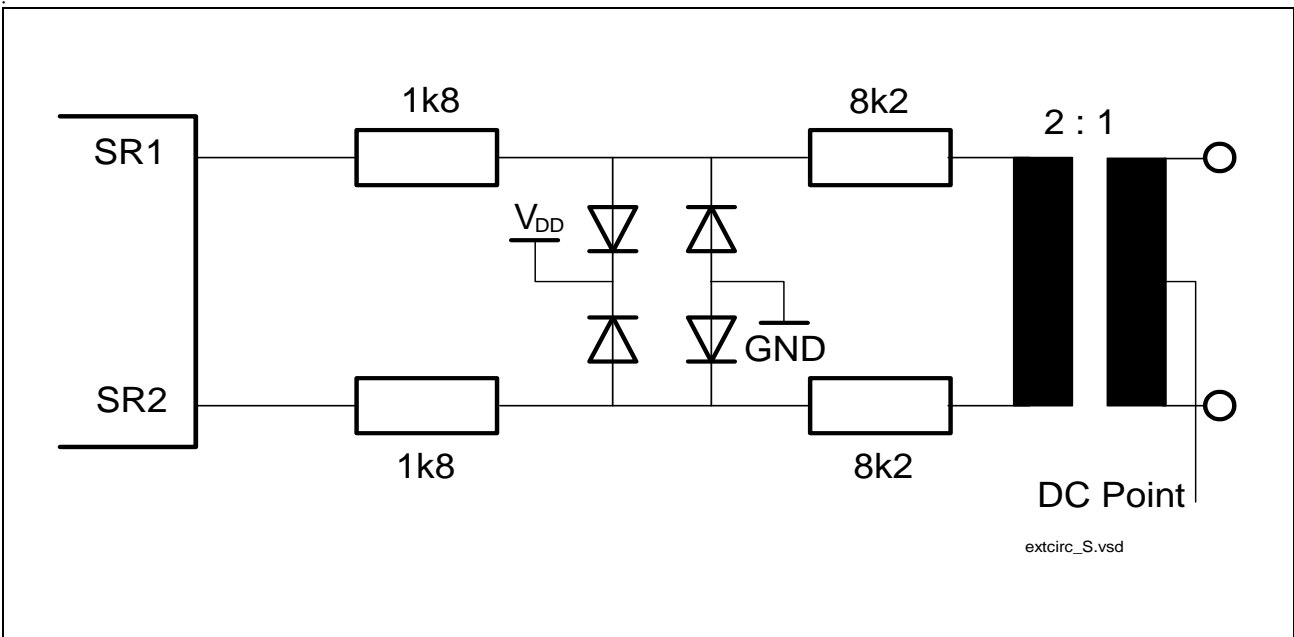

Figure 70 External Circuitry S-Interface Receiver

3.3.4 Oscillator Circuitry

Figure 71 illustrates the recommended oscillator circuit.

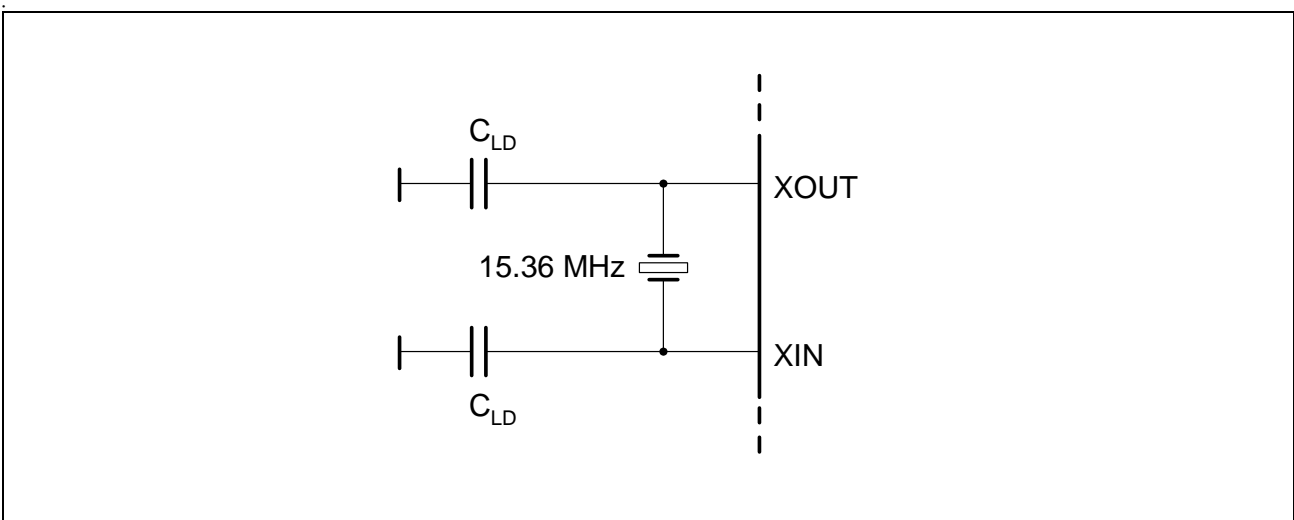

Figure 71 Crystal Oscillator

Operational Description

Table 33 Crystal Parameters

Parameter	Symbol	Limit Values	Unit
Frequency	f	15.36	MHz
Frequency calibration tolerance		+/-60	ppm
Load capacitance	C _L	20	pF
Max. resonance resistance	R1	20	Ω
Max. shunt capacitance	C ₀	7	pF
Oscillator mode		fundamental	

External Components and Parasitics

The load capacitance C_L is computed from the external capacitances C_{LD}, the parasitic capacitances C_{Par} (pin and PCB capacitances to ground and V_{DD}) and the stray capacitance C_{IO} between XIN and XOUT:

$$C_L = \frac{(C_{LD} + C_{Par}) \times (C_{LD} + C_{Par})}{(C_{LD} + C_{Par}) + (C_{LD} + C_{Par})} + C_{IO}$$

For a specific crystal the total load capacitance is predefined, so the equation must be solved for the external capacitances C_{LD}, which is usually the only variable to be determined by the circuit designer. Typical values for the capacitances C_{LD} connected to the crystal are 22 - 33 pF.

3.3.5 General

- low power LEDs
- MLT input supports
 - APC13112
 - AT&T LH1465AB
 - discrete as proposed by Infineon

4 Register Description

4.1 Address Space

7D _H	U-Transceiver
60 _H	Monitor Handler
5C _H	IOM [®] -2 Handler (CDA, TSDP, CR, STI)
40 _H	Interrupt, Global Registers
3C _H	S-Transceiver
30 _H	CI-Register
2E _H	MODEH-Register reserved
22 _H	
00 _H	

Figure 72 Address Space

Register Description

4.2 Interrupts

Special events in the Q-SMINT[®]I are indicated by means of a single interrupt output, which requests the host to read status information from the Q-SMINT[®]I or transfer data from/to the Q-SMINT[®]I.

Since only one $\overline{\text{INT}}$ request output is provided, the cause of an interrupt must be determined by the host reading the interrupt status registers of the Q-SMINT[®]I.

The structure of the interrupt status registers is shown in **Figure 73**.

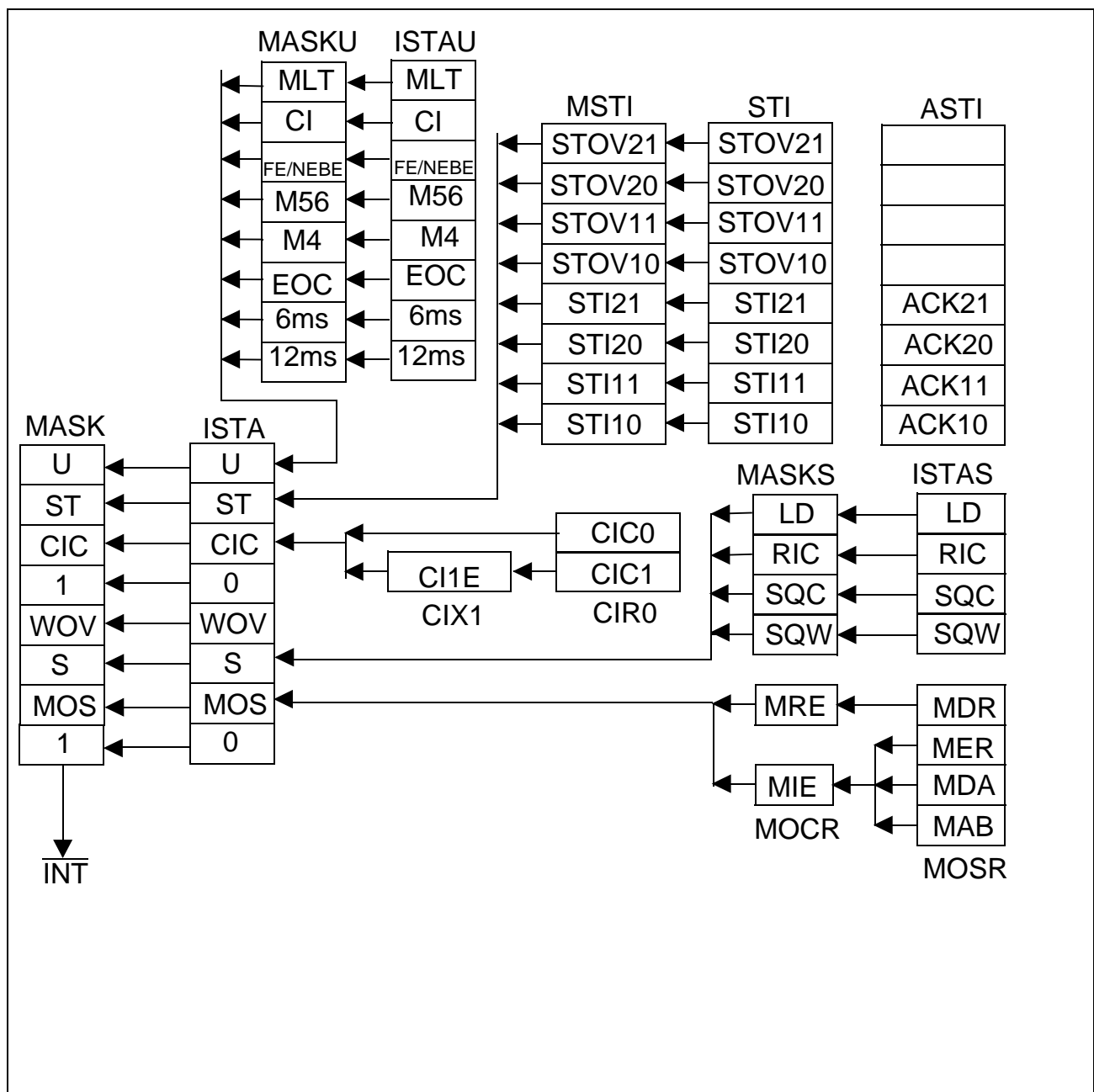

Figure 73 Q-SMINT[®]I Interrupt Status Registers

Register Description

After the Q-SMINT[®]I has requested an interrupt by setting its $\overline{\text{INT}}$ pin to low, the host must read first the Q-SMINT[®]I interrupt status register (ISTA) in the associated interrupt service routine. The $\overline{\text{INT}}$ pin of the Q-SMINT[®]I remains active until all interrupt sources are cleared. Therefore, it is possible that the INT pin is still active when the interrupt service routine is finished.

Each interrupt indication of the interrupt status registers can selectively be masked by setting the respective bit in the MASK register.

For some interrupt controllers or hosts it might be necessary to generate a new edge on the interrupt line to recognize pending interrupts. This can be done by masking all interrupts at the end of the interrupt service routine (writing FF_H into the MASK register) and writing back the old mask to the MASK register.

Register Description

4.3 Register Summary

r(0) = reserved, implemented as zero.

CI Handler

Name	7	6	5	4	3	2	1	0	ADDR	R/W	RES
MODEH	reserved								00 _H -21 _H		
	1	1	0	r(0)	0	DIM2	DIM1	DIM0	22 _H	R/W	C0 _H
	reserved								23 _H -2D _H		
CIR0	CODR0			CIC0	CIC1	S/G	BAS		2E _H	R	F3 _H
CIX0	CODX0			TBA2	TBA1	TBA0	BAC		2E _H	W	FE _H
CIR1	CODR1					CICW	CI1E		2F _H	R	FE _H
CIX1	CODX1					CICW	CI1E		2F _H	W	FE _H

Register Description
S-Transceiver

Name	7	6	5	4	3	2	1	0	ADDR	R/W	RES
S_CONF0	DIS_TR	BUS	EN_ICV	0	L1SW	0	EXLP	0	30 _H	R/W	40 _H
	reserved								31 _H		
S_CONF2	DIS_TX	0	0	0	0	0	0	0	32 _H	R/W	80 _H
S_STA	RINF		0	ICV	0	FSYN	0	LD	33 _H	R	00 _H
S_CMD	XINF			DPRIO	1	PD	LP_A	0	34 _H	R/W	08 _H
SQRR	MSYN	MFEN	0	0	SQR1	SQR2	SQR3	SQR4	35 _H	R	00 _H
SQXR	0	MFEN	0	0	SQX1	SQX2	SQX3	SQX4	35 _H	W	00 _H
	reserved								36 _H -37 _H		
ISTAS	0	x	x	x	LD	RIC	SQC	SQW	38 _H	R	00 _H
MASKS	1	1	1	1	LD	RIC	SQC	SQW	39 _H	R/W	FF _H
S_MODE	0	0	0	0	DCH_INH	MODE2-0			3A _H	R/W	02 _H
	reserved								3B _H		

Register Description

Interrupt, General Configuration

Name	7	6	5	4	3	2	1	0	ADDR	R/W	RES
ISTA	U	ST	CIC	0	WOV	S	MOS	0	3C _H	R	00 _H
MASK	U	ST	CIC	1	WOV	S	MOS	1	3C _H	W	FF _H
MODE1	MCLK		CDS	WTC1	WTC2	CFS	RSS2	RSS1	3D _H	R/W	04 _H
MODE2	LED2	LED1	LEDC	0	0	0	AMOD	PPSDX	3E _H	R/W	00 _H
ID	0	0	DESIGN						3F _H	R	01 _H
SRES	0	0	RES_ CI/TIC	0	0	0	RES_ S	RES_ U	3F _H	W	00 _H

Register Description

IOM Handler (Timeslot, Data Port Selection, CDA Data and CDA Control Register)

Name	7	6	5	4	3	2	1	0	ADDR	R/W	RES
CDA10	Controller Data Access Register								40 _H	R/W	FF _H
CDA11	Controller Data Access Register								41 _H	R/W	FF _H
CDA20	Controller Data Access Register								42 _H	R/W	FF _H
CDA21	Controller Data Access Register								43 _H	R/W	FF _H
CDA_ TSDP10	DPS	0	0	0	TSS				44 _H	R/W	00 _H
CDA_ TSDP11	DPS	0	0	0	TSS				45 _H	R/W	01 _H
CDA_ TSDP20	DPS	0	0	0	TSS				46 _H	R/W	80 _H
CDA_ TSDP21	DPS	0	0	0	TSS				47 _H	R/W	81 _H
	reserved								48 _H - 4B _H		
S_ TSDP_ B1	DPS	0	0	0	TSS				4C _H	R/W	84 _H
S_ TSDP_ B2	DPS	0	0	0	TSS				4D _H	R/W	85 _H
CDA1_ CR	0	0	EN_ TBM	EN_I1	EN_I0	EN_O1	EN_O0	SWAP	4E _H	R/W	00 _H
CDA2_ CR	0	0	EN_ TBM	EN_I1	EN_I0	EN_O1	EN_O0	SWAP	4F _H	R/W	00 _H

Register Description

IOM Handler (Control Registers, Synchronous Transfer Interrupt Control)

Name	7	6	5	4	3	2	1	0	ADDR	R/W	RES
	reserved								50 _H		
S_CR	1	CI_CS	EN_D	EN_B2R	EN_B1R	EN_B2X	EN_B1X	D_CS	51 _H	R/W	FF _H
CI_CR	DPS_CI1	EN_CI1	0	0	0	1	0		52 _H	R/W	04 _H
MON_CR	DPS	EN_MON	0	0	0	0	MCS		53 _H	R/W	40 _H
SDS1_CR	ENS_TSS	ENS_TSS+1	ENS_TSS+3	0	TSS				54 _H	R/W	00 _H
SDS2_CR	ENS_TSS	ENS_TSS+1	ENS_TSS+3	0	TSS				55 _H	R/W	00 _H
IOM_CR	SPU	0	0	TIC_DIS	EN_BCL	0	DIS_OD	DIS_IOM	56 _H	R/W	08 _H
MCDA	MCDA21		MCDA20		MCDA11		MCDA10		57 _H	R	FF _H
STI	STOV ₂₁	STOV ₂₀	STOV ₁₁	STOV ₁₀	STI ₂₁	STI ₂₀	STI ₁₁	STI ₁₀	58 _H	R	00 _H
ASTI	0	0	0	0	ACK ₂₁	ACK ₂₀	ACK ₁₁	ACK ₁₀	58 _H	W	00 _H
MSTI	STOV ₂₁	STOV ₂₀	STOV ₁₁	STOV ₁₀	STI ₂₁	STI ₂₀	STI ₁₁	STI ₁₀	59 _H	R/W	FF _H
	reserved								5A _H -5B _H		

Register Description

MONITOR Handler

Name	7	6	5	4	3	2	1	0	ADDR	R/W	RES
MOR	MONITOR Receive Data								5C _H	R	FF _H
MOX	MONITOR Transmit Data								5C _H	W	FF _H
MOSR	MDR	MER	MDA	MAB	0	0	0	0	5D _H	R	00 _H
MOCR	MRE	MRC	MIE	MXC	0	0	0	0	5E _H	R/W	00 _H
MSTA	0	0	0	0	0	MAC	0	TOUT	5F _H	R	00 _H
MCONF	0	0	0	0	0	0	0	TOUT	5F _H	W	00 _H

Register Description
Register Summary U-Transceiver

Name	7	6	5	4	3	2	1	0	ADDR	R/W	RES
OPMODE	0	UCI	FEBE	MLT	0	CI_SEL	0	0	60 _H	R*/W	14 _H
MFILT	M56 FILTER		M4 FILTER			EOC FILTER			61 _H	R*/W	14 _H
	reserved								62 _H		
EOCR	0	0	0	0	a1	a2	a3	d/m	63 _H	R	0F _H
	i1	i2	i3	i4	i5	i6	i7	i8	64 _H		FF _H
EOCW	0	0	0	0	a1	a2	a3	d/m	65 _H	W	01 _H
	i1	i2	i3	i4	i5	i6	i7	i8	66 _H		00 _H
M4RMASK	M4 Read Mask Bits								67 _H	R*/W	00 _H
M4WMASK	M4 Write Mask Bits								68 _H	R*/W	A8 _H
M4R	verified M4 bit data of last received superframe								69 _H	R	BE _H
M4W	M4 bit data to be send with next superframe								6A _H	R*/W	BE _H
M56R	0	MS2	MS1	NEBE	M61	M52	M51	FEBE	6B _H	R	1F _H
M56W	1	1	1	1	M61	M52	M51	FEBE	6C _H	W	FF _H
UCIR	0	0	0	0	C/I code output				6D _H	R	00 _H
UCIW	0	0	0	0	C/I code input				6E _H	W	01 _H
TEST	0	0	0	0	CCRC	+1 Tones	0	40 KHz	6F _H	R*/W	00 _H
LOOP	0	DLB	TRANS	U/IOM	1	LBBD	LB2	LB1	70 _H	R*/W	08 _H
FEBE	FEBE Counter Value								71 _H	R	00 _H
NEBE	NEBE Counter Value								72 _H	R	00 _H
	reserved								73 _H - 79 _H		

Register Description

ISTAU	MLT	CI	FEBE/ NEBE	M56	M4	EOC	6ms	12ms	7A _H	R	00 _H
MASKU	MLT	CI	FEBE/ NEBE	M56	M4	EOC	6ms	12ms	7B _H	R*/W	FF _H
	reserved								7C _H		
FW_ VERSION	FW Version Number								7D _H	R	6x _H
	reserved								7E _H - 7F _H		

*) read back function for test use

Note: Registers, which are denoted as 'reserved', may not be accessed by the μ C, neither for read nor for write operations.

4.4 Reset of U-Transceiver Functions During Deactivation or with C/I-Code RESET

The following U-transceiver registers are reset during deactivation or with software reset:

Table 34 Reset of U-Transceiver Functions During Deactivation or with C/I-Code RESET

Register	Reset to	Affected Bits
EOCR	0FFF _H	all bits
EOCW	0100 _H	all bits
M4R	BE _H	all bits
M4W	BE _H	all bits
M56R	1F _H	all bits are reset besides MS2 and MS1
M56W	FF _H	all bits
TEST		only bit CCRC is reset
LOOP		only the bits LBBD, LB2 and LB1 are reset

Register Description

4.5 U-Transceiver Mode Register Evaluation Timing

The point of time when mode settings are detected and executed differs with the mode register type. Two different behaviors can be classified:

- evaluation and execution after SW-reset (C/I= RES) or upon transition out of state 'Deactivated'
Note: Write access to these registers/bits is allowed only, while the state machine is in state Reset or Deactivated.
- immediate evaluation and execution

Below the mode registers are listed and grouped according to the different evaluation times as stated above.

Table 35 U-Transceiver Mode Register Evaluation Timing

Register	Affected Bits
----------	---------------

Registers Evaluated After SW-Reset or Upon Transition Out of State Deactivated

OPMODE	bit UCI, MLT
MFILT	complete register

Immediate Evaluation and Execution

OPMODE	bit FEBE, CI_SEL
M4RMASK	complete register
M4WMASK	complete register
TEST	complete register
LOOP	complete register
MASKU	complete register

Register Description

4.6 Detailed C/I Registers

4.6.1 MODEH - Mode Register IOM-2

MODEH read/write Address: 22_H

Value after reset: C0_H

7							0
1	1	0	r(0)	0	DIM2	DIM1	DIM0

DIM2-0 Digital Interface Modes

These bits define the characteristics of the IOM Data Ports (DU, DD). The DIM0 bit enables/disables the stop/go bit (S/G) evaluation. The DIM1 bit enables/disables the TIC bus access. The effect of the individual DIM bits is as follows:

- 0-0 = Stop/go bit evaluation is disabled
- 0-1 = Stop/go bit evaluation is enabled
- 00- = TIC bus access is enabled
- 01- = TIC bus access is disabled
- 1xx = Reserved

4.6.2 CIR0 - Command/Indication Receive 0

CIR0 read Address: 2E_H

Value after reset: F3_H

7					0
CODR0			CIC0	CIC1	S/G BAS

Register Description**CODR0** C/I0 Code Receive

Value of the received Command/Indication code. A C/I-code is loaded in CODR0 only after being the same in two consecutive IOM-frames and the previous code has been read from CIR0.

CIC0 C/I0 Code Change

0 = No change in the received Command/Indication code has been recognized

1 = A change in the received Command/Indication code has been recognized. This bit is set only when a new code is detected in two consecutive IOM-frames. It is reset by a read of CIR0.

CIC1 C/I1 Code Change

0 = No change in the received Command/Indication code has been recognized

1 = A change in the received Command/Indication code in IOM-channel 1 has been recognized. This bit is set when a new code is detected in one IOM-frame. It is reset by a read of CIR0.

S/G Stop/Go Bit Monitoring

Indicates the availability of the upstream D-channel;

0 = Go

1 = Stop

BAS Bus Access Status

Indicates the state of the TIC-bus:

0 = the Q-SMINT[®]I itself occupies the D- and C/I-channel

1 = another device occupies the D- and C/I-channel

Note: The CODR0 bits are updated every time a new C/I-code is detected in two consecutive IOM-frames. If several consecutive valid new codes are detected and CIR0 is not read, only the first and the last C/I code are made available in CIR0 at the first and second read of that register.

Register Description

4.6.3 CIX0 - Command/Indication Transmit 0

CIX0 write Address: 2E_H
 Value after reset: FE_H

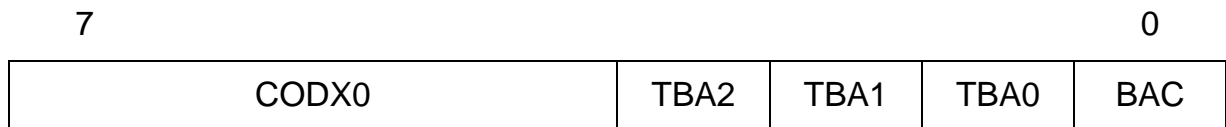

CODX0 C/I0-Code Transmit
 Code to be transmitted in the C/I-channel 0. The code is only transmitted if the TIC bus is occupied, otherwise “1s” are transmitted.

TBA2-0 TIC Bus Address
 Defines the individual address for the Q-SMINT[®]I on the IOM bus. This address is used to access the C/I- and D-channel on the IOM interface.
 Note: If only one device is liable to transmit in the C/I- and D-channels of the IOM it should always be given the address value ‘7’.

BAC Bus Access Control
 Only valid if the TIC-bus feature is enabled (MODE:DIM2-0).
 0 = inactive
 1 = The Q-SMINT[®]I will try to access the TIC-bus to occupy the C/I-channel even if no D-channel frame has to be transmitted. It should be reset when the access has been completed to grant a similar access to other devices transmitting in that IOM-channel.
 Note: Access is always granted by default to the Q-SMINT[®]I with TIC-Bus Address (TBA2-0, CIX0 register) ‘7’, which has the lowest priority in a bus configuration.

Register Description

4.6.4 CIR1 - Command/Indication Receive 1

CIR1 read Address: 2F_H

Value after reset: FE_H

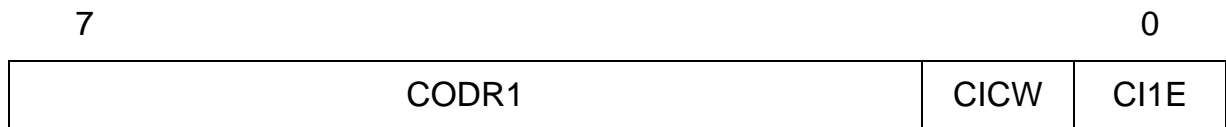

CODR1 C/I1-Code Receive

CICW C/I-Channel Width

Contains the read back value from CIX1 register (see below)

0 = 4 bit C/I1 channel width

1 = 6 bit C/I1 channel width

CI1E C/I1-channel Interrupt Enable

Contains the read back value from CIX1 register (see below)

0 = Interrupt generation ISTA.CIC of CIR0.CIC1 is masked

1 = Interrupt generation ISTA.CIC of CIR0.CIC1 is enabled

4.6.5 CIX1 - Command/Indication Transmit 1

CIX1 write Address: 2F_H

Value after reset: FE_H

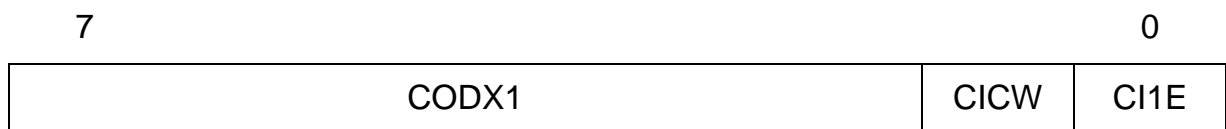

CODX1 C/I1-Code Transmit

Bits 5-0 of C/I-channel 1

CICW C/I-Channel Width

0 = 4 bit C/I1 channel width

Register Description

1 = 6 bit C/I1 channel width

The C/I1 handler always reads and writes 6-bit values but if 4-bit is selected, the higher two bits are ignored for interrupt generation. However, in write direction the full CODX1 code is transmitted, i.e. the host must write the higher two bits to "1".

C11E C/I1-channel Interrupt Enable

0 = Interrupt generation ISTA.CIC of CIR0.CIC1 is masked

1 = Interrupt generation ISTA.CIC of CIR0.CIC1 is enabled

4.7 Detailed S-Transceiver Registers

4.7.1 S_CONF0 - S-Transceiver Configuration Register 0

S_CONF0 read/write Address: 30_H

Value after reset: 40_H

7							0
DIS_TR	BUS	EN_ICV	0	L1SW	0	EXLP	0

DIS_TR Disable Transceiver

0 = All S-transceiver functions are enabled.

1 = All S-transceiver functions are disabled and powered down (analog and digital parts).

BUS Point-to-Point / Bus Selection

0 = Adaptive Timing (Point-to-Point, extended passive bus).

1 = Fixed Timing (Short passive bus), directly derived from transmit clock.

EN_ICV Enable Far End Code Violation

0 = normal operation.

Register Description

1 = ICV enabled. The receipt of at least one illegal code violation within one multi-frame according to ANSI T1.605 is indicated by the C/I indication '1011' (CVR) in two consecutive IOM frames.

L1SW Enable Layer 1 State Machine in Software

0 = Layer 1 state machine of the Q-SMINT[®]I is used.

1 = Layer 1 state machine is disabled. The functionality must be realized in software.

The commands are written to register S_CMD and the status read in the S_STA.

EXLP External Loop

In case the analog loopback is activated with C/I = ARL or with the LP_A bit in the S_CMD register the loop is a

0 = internal loop next to the line pins

1 = external loop which has to be closed between SR1/SR2 and SX1/SX2

Note: For the external loop the transmitter must be enabled (S_CONF2:DIS_TX = 0).

4.7.2 S_CONF2 - S-Transmitter Configuration Register 2

S_CONF2 read/write Address: 32_H

Value after reset: 80_H

7							0
DIS_TX	0	0	0	0	0	0	0

DIS_TX Disable Line Driver

0 = Transmitter is enabled

1 = Transmitter is disabled

Register Description

4.7.3 S_STA - S-Transceiver Status Register

S_STA read Address: 33_H

Value after reset: 00_H

7						0
RINF	0	ICV	0	FSYN	0	LD

Important: This register is used only if the Layer 1 state machine of the device is disabled (S_CONFO:L1SW = 1) and implemented in software! With the layer 1 state machine enabled, the signals from this register are automatically evaluated.

RINF Receiver INFO

- 00 = Received INFO 0 (no signal)
- 01 = Received any signal except INFO 0 or INFO 3
- 10 = reserved
- 11 = Received INFO 3

ICV Illegal Code Violation

- 0 = No illegal code violation is detected.
- 1 = Illegal code violation (ANSI T1.605) in data stream is detected.

FSYN Frame Synchronization State

- 0 = The S/T receiver is not synchronized.
- 1 = The S/T receiver has synchronized to the framing bit F.

LD Level Detection

- 0 = No receive signal has been detected on the line.
- 1 = Any receive signal has been detected on the line.

Register Description

4.7.4 S_CMD - S-Transceiver Command Register

S_CMD read/write Address: 34_H

Value after reset: 08_H

7	0
XINF	DPRIO 1 PD LP_A 0

Important: This register - except bit DPRIO - is writable only if the Layer 1 state machine of the device is disabled (S_CONF0.L1SW = 1) and implemented in software! With the device layer 1 state machine enabled, the signals from this register are automatically generated. DPRIO can also be written in intelligent NT mode.

XINF Transmit INFO
 000 = Transmit INFO 0
 001 = reserved
 010 = Transmit INFO 2
 011 = Transmit INFO 4
 100 = Send continuous pulses at 192 kbit/s alternating or 96 kHz rectangular, respectively (TM2)
 101 = Send single pulses at 4 kbit/s with alternating polarity corresponding to 2 kHz fundamental mode (TM1)
 11x = reserved

DPRIO D-Channel Priority
 0 = Priority class 1 for D channel access on IOM
 1 = Priority class 2 for D channel access on IOM

PD Power Down
 0 = The transceiver is set to operational mode
 1 = The transceiver is set to power down mode

LP_A Loop Analog
 The setting of this bit corresponds to the C/I command ARL.

Register Description

- 0 = Analog loop is open
- 1 = Analog loop is closed internally or externally according to the EXLP bit in the S_CONF0 register

4.7.5 SQRR - S/Q-Channel Receive Register

SQRR read Address: 35_H

Value after reset: 00_H

7							0
MSYN	MFEN	0	0	SQR1	SQR2	SQR3	SQR4

MSYN Multi-frame Synchronization State

- 0 = The S/T receiver has not synchronized to the received F_A and M bits
- 1 = The S/T receiver has synchronized to the received F_A and M bits

MFEN Multiframe Enable

Read-back of the MFEN bit of the SQXR register

- 0 = S/T multiframe is disabled
- 1 = S/T multiframe is enabled

SQR1-4 Received S/Q Bits

Received Q bits in frames 1, 6, 11 and 16

4.7.6 SQXR- S/Q-Channel Transmit Register

SQXR write Address: 35_H

Value after reset: 00_H

7							0
0	MFEN	0	0	SQX1	SQX2	SQX3	SQX4

Register Description

SQC S/Q-Channel Change
 0 = inactive
 1 = A change in the received 4-bit Q-channel has been detected. The new code can be read from the SQRx bits of registers SQRR within the next multiframe¹⁾. This bit is reset by a read access to the SQRR register.

SQW S/Q-Channel Writable
 0 = inactive
 1 = The S channel data for the next multiframe is writable. The register for the S bits to be transmitted has to be written within the next multiframe. This bit is reset by writing register SQXR. This timing signal is indicated with the start of every multiframe. Data which is written right after SQW-indication will be transmitted with the start of the following multiframe. Data which is written before SQW-indication is transmitted in the multiframe which is indicated by SQW.
 SQW and SQC could be generated at the same time.

¹⁾ Register SQRR stays valid as long as no code change has been received.

4.7.8 MASKS - Mask S-Transceiver Interrupt

MASKS read/write Address: 39_H
 Value after reset: FF_H

7							0
1	1	1	1	LD	RIC	SQC	SQW

Bit 3..0 Mask bits
 0 = The transceiver interrupts LD, RIC, SQC and SQW are enabled
 1 = The transceiver interrupts LD, RIC, SQC and SQW are masked

Register Description

4.7.9 S_MODE - S-Transceiver Mode

S_MODE read/write Address: 3A_H

Value after reset: 02_H

7					0
0	0	0	0	DCH_INH	MODE

DCH_ D-Channel Inhibit
INH

0 = inactive

1 = The S-transceiver blocks the access to the D-channel on S by inverting the E-bits.

MODE Mode Selection

000 = reserved

001 = reserved

010 = NT (without D-channel handler)

011 = LT-S (without D-channel handler)

110 Intelligent NT mode (with NT state machine and with D-channel handler)

111 Intelligent NT mode (with LT-S state machine and with D-channel handler)

100 reserved

101 reserved

Register Description

4.8 Interrupt and General Configuration Registers

4.8.1 ISTA - Interrupt Status Register

ISTA read Address: 3C_H
 Value after reset: 00_H

7							0
U	ST	CIC	0	WOV	S	MOS	0

- U** U-Transceiver Interrupt
 0 = inactive
 1 = An interrupt was generated by the U-transceiver. Read the ISTAU register.

- ST** Synchronous Transfer
 0 = inactive
 1 = This interrupt enables the microcontroller to lock on to the IOM[®]-2 timing, for synchronous transfers.

- CIC** C/I Channel Change
 0 = inactive
 1 = A change in C/I0 channel or C/I1 channel has been recognized. The actual value can be read from CIR0 or CIR1.
 0 = inactive

- WOV** Watchdog Timer Overflow
 0 = inactive
 1 = Signals the expiration of the watchdog timer, which means that the microcontroller has failed to set the watchdog timer control bits WTC1 and WTC2 (MODE1 register) in the correct manner. A reset out pulse on pin $\overline{\text{RSTO}}$ has been generated by the Q-SMINT[®].

- S** S-Transceiver Interrupt

Register Description

- 0 = inactive
- 1 = An interrupt was generated by the S-transceiver. Read the ISTAS register.

MOS MONITOR Status

- 0 = inactive
- 1 = A change in the MONITOR Status Register (MOSR) has occurred.
- 0 = inactive

Note: A read of the ISTA register clears only the WOV interrupt. The other interrupts are cleared by reading the corresponding status register.

4.8.2 MASK - Mask Register

MASK write Address: 3C_H
 Value after reset: FF_H

	7							0
	U	ST	CIC	1	WOV	S	MOS	1

Bit 7..0 Mask bits

- 0 = Interrupt is not masked
- 1 = Interrupt is masked

Each interrupt source in the ISTA register can be selectively masked by setting the corresponding bit in MASK to '1'. Masked interrupt status bits are not indicated when ISTA is read. Instead, they remain internally stored and pending, until the mask bit is reset to '0'.

Note: In the event of a C/I channel change, CIC is set in ISTA even if the corresponding mask bit in MASK is active, but no interrupt is generated.

Register Description

4.8.3 MODE1 - Mode1 Register

MODE1 read/write Address: 3D_H

Value after reset: 04_H

7							0
MCLK	CDS	WTC1	WTC2	CFS	RSS2	RSS1	

MCLK Master Clock Frequency

The Master Clock Frequency bits control the microcontroller clock output depending on MODE1.CDS = '0' or '1' (Table [Table 2.1.3](#)).

	MODE1.CDS = '0'	MODE1.CDS = '1'
00 =	3.84 MHz	7.68 MHz
01 =	0.96 MHz	1.92 MHz
10 =	7.68 MHz	15.36 MHz
11 =	disabled	disabled

CDS Clock Divider Selection

- 0 = The 15.36 MHz oscillator clock divided by two is input to the MCLK prescaler
- 1 = The 15.36 MHz oscillator clock is input to the MCLK prescaler.

WTC1, 2 Watchdog Timer Control 1, 2

After the watchdog timer mode has been selected (RSS = '11') the watchdog timer is started. During every time period of 128 ms the microcontroller has to program the WTC1 and WTC2 bit in the following sequence ([Chapter 2.2](#)):

- 10 first step
- 01 second step

to reset and restart the watchdog timer.

If not, the timer expires and a WOV-interrupt (ISTA Register) together with a reset out pulse on pin RSTO is generated.

The watchdog timer runs only when the internal IOM[®]-2 clocks are active, i.e. the watchdog timer is dead when bit CFS = 1 and the U and S-transceivers are in state power down.

Register Description

CFS Configuration Select

- 0 = The IOM[®]-2 interface clock and frame signals are always active, “Deactivated State” of the U-transceiver and the S-transceiver included.
- 1 = The IOM[®]-2 interface clocks and frame signals are inactive in the “Deactivated State” of the U-transceiver and the S-transceiver.

RSS2, RSS1 Reset Source Selection 2,1

The Q-SMINT[®]I reset sources can be selected according to the table below.

	C/I Code Change	Watchdog Timer	POR/UVD and \overline{RST}
00 =	--	--	x
01 =	\overline{RSTO} disabled (high impedance)		
10 =	x	--	x
11 =	--	x	x

4.8.4 MODE2 - Mode2 Register

MODE2 read/write Address: 3E_H

Value after reset: 00_H

7							0
LED2	LED1	LEDC	0	0	0	AMOD	PPSDX

LED2,1 LED Control on pin \overline{ACT}

- 00 = High
- 01 = flashing at 8 Hz
- 10 = flashing at 1 Hz
- 11 = Low

LEDC LED Control Enable

- 0 = LED is controlled by the state machines as defined in [Table 3](#).
- 1 = LED is controlled via bits LED2,1.

Register Description

AMOD Address Mode

Selects between direct and indirect register access of the parallel microcontroller interface.

- 0 = Indirect address mode is selected. The address line A0 is used to select between address (A0 = '0') and data (A0 = '1') register
- 1 = Direct address mode is selected. The address is applied to the address bus (A0-A6)

PPSDX Push/Pull Output for SDX

- 0 = The SDX pin has open drain characteristic
- 1 = The SDX pin has push/pull characteristic

4.8.5 ID - Identification Register

ID read Address: 3F_H

Value after reset: 01_H

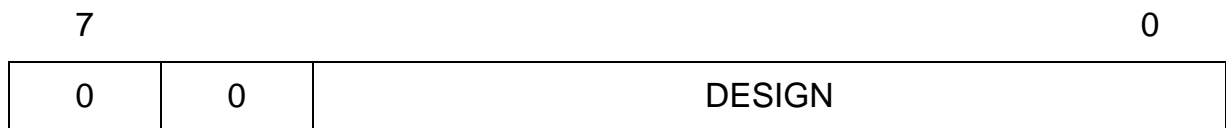

DESIGN Design Number

The design number (DESIGN) allows to identify different hardware designs¹⁾ of the Q-SMINT[®]I by software.

- 000000: Version 1.1
- 000001: Version 1.2
- 000001: Version 1.3

¹⁾ Distinction of different firmware versions is also possible by reading register (7D)_H in the address space of the U-transceiver (see [Chapter 4.11.19](#)).

Register Description

4.8.6 SRES - Software Reset Register

SRES write Address: 3F_H
 Value after reset: 00_H

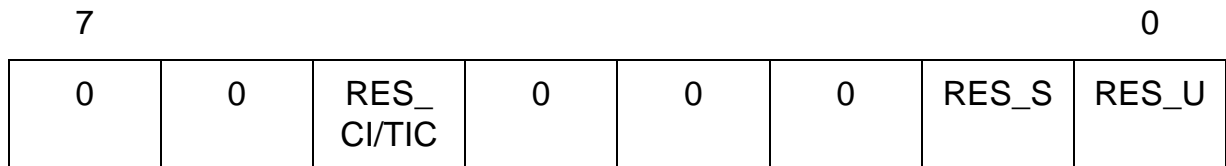

RES_xx Reset_xx
 0 = Deactivates the reset of the functional block xx
 1 = Activates the reset of the functional block xx.
 The reset state is activated as long as the bit is set to ‘1’

4.9 Detailed IOM[®]-2 Handler Registers

4.9.1 CDAXy - Controller Data Access Register xy

These registers are used for microcontroller access to the IOM[®]-2 timeslots as well as for timeslot manipulations. (e.g. loops, shifts, ... see also [“Controller Data Access \(CDA\)” on Page 31](#)).

CDAXy read/write Address: 40-43_H

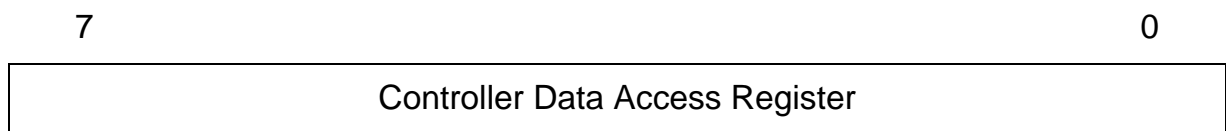

Data register CDAXy which can be accessed by the controller.

Register	Value after Reset	Register Address
CDA10	FF _H	40 _H
CDA11	FF _H	41 _H
CDA20	FF _H	42 _H
CDA21	FF _H	43 _H

Register Description

4.9.2 XXX_TSDPxy - Time Slot and Data Port Selection for CHxy

XXX_TSDPxy read/write Address: 44-4D_H



Register	Value after Reset	Register Address
CDA_TSDP10	00 _H (= output on B1-DD)	44 _H
CDA_TSDP11	01 _H (= output on B2-DD)	45 _H
CDA_TSDP20	80 _H (= output on B1-DU)	46 _H
CDA_TSDP21	81 _H (= output on B2-DU)	47 _H
	reserved	48-4B _H
S_TSDP_B1	84 _H (= output on TS4-DU)	4C _H
S_TSDP_B2	85 _H (= output on TS5-DU)	4D _H

This register determines the time slots and the data ports on the IOM[®]-2 Interface for the data channels xy of the functional units XXX (Controller Data Access (CDA) and S-transceiver (S)).

Note: The U-transceiver is always in IOM-2 channel 0.

DPS Data Port Selection

- 0 = The data channel xy of the functional unit XXX is output on DD.
The data channel xy of the functional unit XXX is input from DU.
- 1 = The data channel xy of the functional unit XXX is output on DU.
The data channel xy of the functional unit XXX is input from DD.

Note: For the CDA (controller data access) data the input is determined by the CDAX_x_CR.SWAP bit. If SWAP = '0' the input for the CDAX_y data is vice versa to the output setting for CDAX_y. If the SWAP = '1' the input from CDAX₀ is vice versa to the output setting of CDAX₁ and the input from CDAX₁ is vice versa to the output setting of CDAX₀.

TSS Timeslot Selection

Selects one of the 12 timeslots from 0...11 on the IOM[®]-2 interface for the data channels.

Register Description

4.9.3 CDAX_CR - Control Register Controller Data Access CH1x

CDAX_CR read/write Address: 4E-4F_H

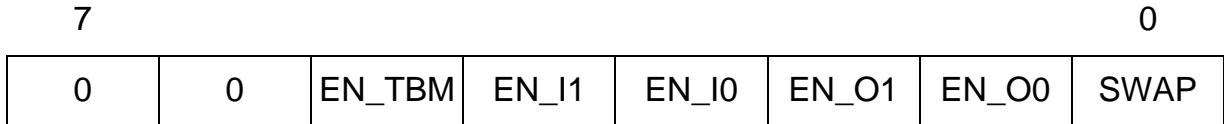

Register	Value after Reset	Register Address
CDA1_CR	00 _H	4E _H
CDA2_CR	00 _H	4F _H

EN_TBM Enable TIC Bus Monitoring

- 0 = The TIC bus monitoring is disabled
- 1 = The TIC bus monitoring with the CDAX0 register is enabled. The TSDPx0 register must be set to 08_H for monitoring from DU, or 88_H for monitoring from DD.

EN_I1, EN_I0 Enable Input CDAX1, CDAX0

- 0 = The input of the CDAX1, CDAX0 register is disabled
- 1 = The input of the CDAX1, CDAX0 register is enabled

EN_O1, EN_O0 Enable Output CDAX1, CDAX0

- 0 = The output of the CDAX1, CDAX0 register is disabled
- 1 = The output of the CDAX1, CDAX0 register is enabled

Register Description

SWAP Swap Inputs

- 0 = The time slot and data port for the input of the CDAXy register is defined by its own TSDPx_y register. The data port for the CDAXy input is vice versa to the output setting for CDAXy.
- 1 = The input (time slot and data port) of the CDAX0 is defined by the TSDP register of CDAX1 and the input of CDAX1 is defined by the TSDP register of CDAX0. The data port for the CDAX0 input is vice versa to the output setting for CDAX1. The data port for the CDAX1 input is vice versa to the output setting for CDAX0. The input definition for time slot and data port CDAX0 are thus swapped to CDAX1 and for CDAX1 to CDAX0. The outputs are not affected by the SWAP bit.

4.9.4 S_CR - Control Register S-Transceiver Data

S_CR read/write Address: 51_H
 Value after reset: FF_H

	7							0
1	CI_CS	EN_D	EN_B2R	EN_B1R	EN_B2X	EN_B1X	D_CS	

CI_CS C/I Channel Selection

This bit is used to select the IOM channel to which the S-transceiver C/I-channel is related to.

- 0 = C/I-channel in IOM-channel 0
- 1 = C/I-channel in IOM-channel 1

EN_D Enable Transceiver D-Channel Data

- 0 = The corresponding data path to the transceiver is disabled
- 1 = The corresponding data path to the transceiver is enabled.

EN_B2R Enable Transceiver B2 Receive Data (transmitter receives from IOM)

- 0 = The corresponding data path to the transceiver is disabled

Register Description

1 = The corresponding data path to the transceiver is enabled.

EN_B1R Enable Transceiver B1 Receive Data (transmitter receives from IOM)

0 = The corresponding data path to the transceiver is disabled

1 = The corresponding data path to the transceiver is enabled.

EN_B2X Enable Transceiver B2 Transmit Data (transmitter transmits to IOM)

0 = The corresponding data path to the transceiver is disabled

1 = The corresponding data path to the transceiver is enabled.

EN_B1X Enable Transceiver B1 Transmit Data (transmitter transmits to IOM)

0 = The corresponding data path to the transceiver is disabled

1 = The corresponding data path to the transceiver is enabled.

These bits are used to individually enable/disable the D-channel and the receive/transmit paths for the B-channels for the S-transceiver.

D_CS D Channel Selection

This bit is used to select the IOM channel to which the S-transceiver D-channel is related to.

0 = D-channel in IOM-channel 0

1 = D-channel in IOM-channel 1

4.9.5 CI_CR - Control Register for CI1 Data

CI_CR read/write Address: 52_H

Value after reset: 04_H

7							0
DPS_CI1	EN_CI1	0	0	0	1	0	

DPS_CI1 Data Port Selection CI1 Handler

0 = The CI1 data is output on DD and input from DU

1 = The CI1 data is output on DU and input from DD

Register Description

EN_CI1 Enable CI1 Handler

- 0 = CI1 data access is disabled
- 1 = CI1 data access is enabled

Note: The timeslot for the C/I1 handler cannot be programmed but is fixed to IOM channel 1.

4.9.6 MON_CR - Control Register Monitor Data

MON_CR read/write Address: 53_H

Value after reset: 40_H

	7						0
DPS	EN_MON	0	0	0	0	MCS	

DPS Data Port Selection

- 0 = The Monitor data is output on DD and input from DU
- 1 = The Monitor data is output on DU and input from DD

EN_MON Enable Output

- 0 = The Monitor data input and output is disabled
- 1 = The Monitor data input and output is enabled

MCS MONITOR Channel Selection

- 00 = The MONITOR data is output on MON0
- 01 = The MONITOR data is output on MON1
- 10 = The MONITOR data is output on MON2
- 11 = Not defined

Register Description

4.9.9 IOM_CR - Control Register IOM Data

IOM_CR read/write Address: 56_H

Value after reset: 08_H

7							0
SPU	0	0	TIC_DIS	EN_BCL	0	DIS_OD	DIS_IOM

- SPU** Software Power UP
- 0 = The DU line is normally used for transmitting data.
 - 1 = Setting this bit to '1' will pull the DU line to low. This will enforce the Q-SMINT[®]I and other connected layer 1 devices to deliver IOM-clocking.
- TIC_DIS** TIC Bus Disable
- 0 = The last octet of the last IOM time slot (TS 11) is used as TIC bus.
 - 1 = The TIC bus is disabled. The last octet of the last IOM time slot (TS 11) can be used like any other time slot. This means that the timeslots TIC, A/B, S/G and BAC are not available any more.
- EN_BCL** Enable Bit Clock BCL
- 0 = The BCL clock is disabled (output is high impedant)
 - 1 = The BCL clock is enabled
- DIS_OD** Disable Open Drain
- 0 = IOM outputs are open drain driver
 - 1 = IOM outputs are push pull driver
- DIS_IOM** Disable IOM
- DIS_IOM should be set to '1' if external devices connected to the IOM interface should be "disconnected" e.g. for power saving purposes. However, the Q-SMINT[®]I internal operation is independent of the DIS_IOM bit.

Register Description

- 0 = The IOM interface is enabled
- 1 = The IOM interface is disabled (FSC, DCL, clock outputs have high impedance; DU, DD data line inputs are switched off and outputs are high impedant)

4.9.10 MCDA - Monitoring CDA Bits

MCDA read Address: 57_H
 Value after reset: FF_H

7						0	
MCDA21		MCDA20		MCDA11		MCDA10	
Bit7	Bit6	Bit7	Bit6	Bit7	Bit6	Bit7	Bit6

MCDA_{xy} Monitoring CDA_{xy} Bits

Bit 7 and Bit 6 of the CDA_{xy} registers are mapped into the MCDA register. This can be used for monitoring the D-channel bits on DU and DD and the “Echo bits” on the TIC bus with the same register.

4.9.11 STI - Synchronous Transfer Interrupt

STI read Address: 58_H
 Value after reset: 00_H

7								0			
STOV21	STOV20	STOV11	STOV10	STI21	STI20	STI11	STI10				

For all interrupts in the STI register the following logical states are applied

- 0 = Interrupt has not occurred
- 1 = Interrupt has occurred

STOV_{xy} Synchronous Transfer Overflow Interrupt

Register Description

Enabled STOV interrupts for a certain STI_{xy} interrupt are generated when the STI_{xy} has not been acknowledged in time via the ACK_{xy} bit in the ASTI register. This must be one (for DPS = '0') or zero (for DPS = '1') BCL clock cycles before the time slot which is selected for the STOV.

STI_{xy} Synchronous Transfer Interrupt

Depending on the DPS bit in the corresponding TSDP_{xy} register the Synchronous Transfer Interrupt STI_{xy} is generated two (for DPS = '0') or one (for DPS = '1') BCL clock cycles after the selected time slot (TSDP_{xy}.TSS).

Note: STOV_{xy} and ACK_{xy} are useful for synchronizing microcontroller accesses and receive/transmit operations. One BCL clock is equivalent to two DCL clocks.

4.9.12 ASTI - Acknowledge Synchronous Transfer Interrupt

ASTI write Address: 58_H
Value after reset: 00_H

7							0
0	0	0	0	ACK21	ACK20	ACK11	ACK10

ACK_{xy} Acknowledge Synchronous Transfer Interrupt

After a STI_{xy} interrupt the microcontroller has to acknowledge the interrupt by setting the corresponding ACK_{xy} bit.

0 = No activity is initiated

1 = Sets the acknowledge bit ACK_{xy} for a STI_{xy} interrupt

4.9.13 MSTI - Mask Synchronous Transfer Interrupt

MSTI read/write Address: 59_H
Value after reset: FF_H

7							0
STOV21	STOV20	STOV11	STOV10	STI21	STI20	STI11	STI10

Register Description

For the MSTI register the following logical states are applied:

- 0 = Interrupt is not masked
- 1 = Interrupt is masked

STOVxy Mask Synchronous Transfer Overflow xy
Mask bits for the corresponding STOVxy interrupt bits.

STlxy Synchronous Transfer Interrupt xy
Mask bits for the corresponding STlxy interrupt bits.

4.10 Detailed MONITOR Handler Registers

4.10.1 MOR - MONITOR Receive Channel

MOR read Address: 5C_H

Value after reset: FF_H

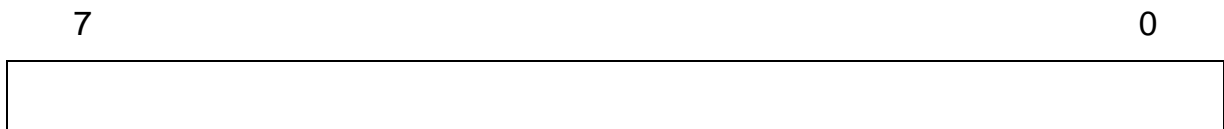

Contains the MONITOR data received in the IOM[®]-2 MONITOR channel according to the MONITOR channel protocol. The MONITOR channel (0,1,2) can be selected by setting the monitor channel select bit MON_CR.MCS.

4.10.2 MOX - MONITOR Transmit Channel

MOX write Address: 5C_H

Value after reset: FF_H

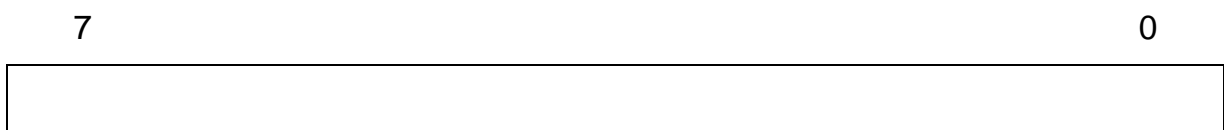

Contains the MONITOR data to be transmitted in IOM[®]-2 MONITOR channel according to the MONITOR channel protocol. The MONITOR channel (0,1,2) can be selected by setting the monitor channel select bit MON_CR.MCS

Register Description

4.10.3 MOSR - MONITOR Interrupt Status Register

MOSR read Address: 5D_H
 Value after reset: 00_H

7							0
MDR	MER	MDA	MAB	0	0	0	0

MDR MONITOR channel Data Received
 0 = inactive
 1 = MONITOR channel Data Received

MER MONITOR channel End of Reception
 0 = inactive
 1 = MONITOR channel End of Reception

MDA MONITOR channel Data Acknowledged
 The remote end has acknowledged the MONITOR byte being transmitted.
 0 = inactive
 1 = MONITOR channel Data Acknowledged

MAB MONITOR channel Data Abort
 0 = inactive
 1 = MONITOR channel Data Abort

4.10.4 MOCR - MONITOR Control Register

MOCR read/write Address: 5E_H
 Value after reset: 00_H

7							0
MRE	MRC	MIE	MXC	0	0	0	0

Register Description

MRE MONITOR Receive Interrupt Enable

- 0 = MONITOR interrupt status MDR generation is masked.
- 1 = MONITOR interrupt status MDR generation is enabled.

MRC MR Bit Control

Determines the value of the MR bit:

- 0 = MR is always '1'. In addition, the MDR interrupt is blocked, except for the first byte of a packet (if MRE = 1).
- 1 = MR is internally controlled by the Q-SMINT[®]I according to MONITOR channel protocol. In addition, the MDR interrupt is enabled for all received bytes according to the MONITOR channel protocol (if MRE = 1).

MIE MONITOR Interrupt Enable

- 0 = MONITOR interrupt status MER, MDA, MAB generation is masked
- 1 = MONITOR interrupt status MER, MDA, MAB generation is enabled

MXC MX Bit Control

Determines the value of the MX bit:

- 0 = The MX bit is always '1'.
- 1 = The MX bit is internally controlled by the Q-SMINT[®]I according to MONITOR channel protocol.

4.10.5 MSTA - MONITOR Status Register

MSTA read Address: 5F_H
 Value after reset: 00_H

	7							0
	0	0	0	0	0	MAC	0	TOUT

Register Description

MAC MONITOR Transmit Channel Active
 0 = No data transmission in the MONITOR channel
 1 = The data transmission in the MONITOR channel is in progress.

TOUT Time-Out
 Read-back value of the TOUT bit
 0 = The monitor time-out function is disabled
 1 = The monitor time-out function is enabled

4.10.6 MCONF - MONITOR Configuration Register

MCONF write Address: 5F_H
 Value after reset: 00_H

7							0
0	0	0	0	0	0	0	TOUT

TOUT Time-Out
 0 = The monitor time-out function is disabled
 1 = The monitor time-out function is enabled

4.11 Detailed U-Transceiver Registers

4.11.1 OPMODE - Operation Mode Register

The **Operation Mode** register determines the operating mode of the U-transceiver.

OPMODE read*/write Address: 60_H
 Reset Value: 14_H

7	6	5	4	3	2	1	0
0	UCI	FEBE	MLT	0	CI_SEL	0	0

Register Description

- UCI** Enable/Disable μ C Control of C/I Codes
 0 = μ C control disabled - C/I codes are exchanged via IOM[®]-2
 Read access to register UCIR by the μ P is still possible
 1 = μ C control enabled - C/I codes are exchanged via UCIR and UCIW registers
 In this case, the according C/I-channel on IOM[®]-2 is idle '1111'
- FEBE** Enable/Disable External Write Access to FEBE Bit in Register M56W
 0 = external access to FEBE bit disabled - FEBE bit is controlled by internal FEBE counter
 1 = external access to FEBE bit enabled - FEBE bit is controlled by external microprocessor
- MLT** Enable/Disable Metallic Loop Termination Function
 MLT status is reflected in bit MS2 and MS1 in register M56R
 0 = MLT disabled
 1 = MLT enabled
- CI_SEL** C/I Code Output Selection
 by CI_SEL the user can switch:
 – between the standard C/I indications of the NT state machine as implemented in today's IEC-Q versions or
 – newly defined C/I code indications which facilitates control and debugging
 0 = Standard NT state machine compliant to NT state machine of today's IEC-Q V4.3-V5.3
 1 = Simplified NT state machine output of newly defined C/I code indications for enhanced activation/deactivation control and debugging facilities

4.11.2 MFILT - M Bit Filter Options

The **M Bit Filter** register defines the validation algorithm received Maintenance channel bits (EOC, M4, M56) of the U-interface have to undergo before they are approved and passed on to the μ C.

MFILT read*/write Address: 61_H
 Reset Value: 14_H

Register Description

7	6	5	4	3	2	1	0
M56 FILTER			M4 FILTER			EOC FILTER	

M56 FILTER controls the validation mode of the spare bits (M51, M52, M61) **on a per bit base** (see [Chapter 2.4.4.3](#)).

X0 = Apply **same filter** to M5 and M6 bit data as programmed for M4 bit data.

X1 = **On Change**

M4 Filter 3-bit field which controls the validation mode of the M4 bits **on a per bit base** (see [Chapter 2.4.4.1](#)).

x00 = **On Change**

x01 = **TLL coverage** of M4 bit data

x10 = **CRC coverage** of M4 bit data

x11 = **CRC and TLL coverage** of M4 bit data

0xx = M4 bits **towards state machine** are **covered by TLL**.

1xx = M4 bits **towards state machine** are checked by the same validation algorithm as programmed for the reporting to the system interface (see [Chapter 2.4.4.2](#)).

EOC FILTER 3-bit field which controls the processing of EOC messages and its verification algorithm (see [Chapter 2.4.3.3](#)).

100 = **EOC automatic mode**

001 = **EOC transparent mode without any filtering**

010 = **EOC transparent mode with 'on change' filtering**

011 = **EOC transparent mode with Triple-Last-Look (TLL) Filtering**

4.11.3 EOCR - EOC Read Register

The **EOC Read** register contains the last verified EOC message (M1-M3 bits) according to the verification criterion selected in MFILT.EOC FILTER.

EOCR read Address: 63_H

Reset Value: 0FFF_H

Register Description

15	14	13	12	11	10	9	8
0	0	0	0	a1	a2	a3	d/m
7	6	5	4	3	2	1	0
i1	i2	i3	i4	i5	i6	i7	i8

EOC Embedded Operations Channel (see [Chapter 2.4.3](#))

a1 .. a3 address field

d/m data/ message indicator

i1 .. i8 information field,

4.11.4 EOCW - EOC Write Register

Via the **EOC Write** register, the EOC message (M1-M3 bits) of the next available U superframe can be sent and it will be repeated until a new value is written to EOCW, or the line is deactivated.

Access to the EOCW register is reasonably only if the EOC channel is operated in 'Transparent mode', otherwise conflicts with the internal EOC processor may occur.

EOCW **write** Address: 65_H

Reset Value: 0100_H

15	14	13	12	11	10	9	8
0	0	0	0	a1	a2	a3	d/m
7	6	5	4	3	2	1	0
i1	i2	i3	i4	i5	i6	i7	i8

Register Description

a1 .. a3 address field

d/m data/ message indicator

i1 .. i8 information field (8 codes are reserved by ANSI/ETSI for diagnostic and loopback functions)

4.11.5 M4RMASK - M4 Read Mask Register

Via the **M4 Read Mask** register, the user can selectively control which M4 bit changes are reported via interrupt requests.

M4RMASK read^{*)}/write Address: 67_H
 Reset Value: 00_H

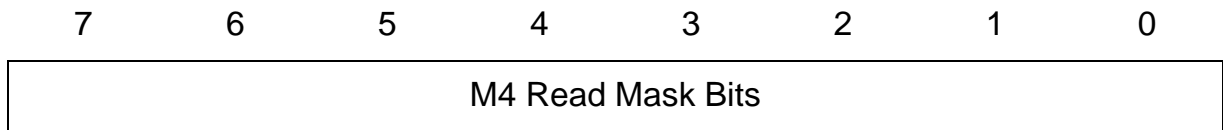

Bit 0..7

- 0 = M4 bit change indication by interrupt active
- 1 = M4 bit change indication by interrupt masked

4.11.6 M4WMASK - M4 Write Mask Register

Access to the **M4 Write Mask** register (M4W) is controlled by the **M4WMASK** register. By means of the M4WMASK register the user can control on a per bit base which M4 bits are controlled by the user and which are controlled by the state machine.

M4WMASK read^{*)}/write Address: 68_H
 Reset Value: A8_H

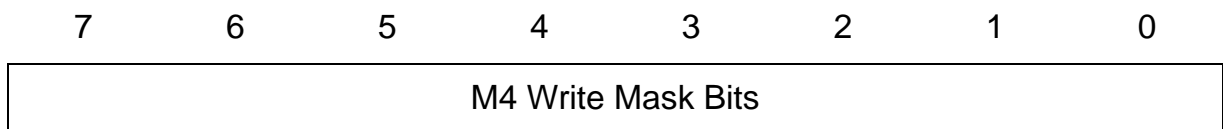

Register Description

Bit 0..7

- 0 = M4 bit is controlled by state machine/ external pins (PS1,2)
- 1 = M4 bit is controlled by μ C

Bit 6 Partial Activation Control External/Automatic,

function corresponds to the MON-8 commands PACE and PACA

- 0 = SAI bit is controlled and UOA bit is evaluated by state machine
- 1 = SAI bit is controlled via the μ C, UOA=1 is reported to the state machine

4.11.7 M4R - M4 Read

The Read **M4** bit register contains the last received and verified M4 bit data.

M4R **read** Address: 69_H

Reset Value: BE_H

7	6	5	4	3	2	1	0
AIB	UOA	M46	M45	M44	SCO	DEA	ACT

AIB Interruption (according to ANSI)

- 0 = indicates interruption
- 1 = inactive

UOA U Activation Only

- 0 = indicates that only U is activated
- 1 = inactive

SCO Start-on-Command Only Bit

indicates whether the DLC network will deactivate the loop between calls (defined in Bellcore TR-NWT000397)

- 0 = Start-on-Command-Only mode active, in LULT mode the U-transceiver shall initiate the start-up procedure only upon command from the network ('AR' primitive)

Register Description

1 = normal mode,
if the U-transceiver is operated within a DCL configuration as LULT
it shall start operation as soon as power is applied

DEA Deactivation Bit

0 = LT informs NT that it will turn off
1 = inactive

ACT Activation Bit

0 = layer 2 not established
1 = signals layer 2 ready for communication

4.11.8 M4W - M4 Write Register

Via the **M4** bit **Write** register the M4 bits of the next available U-superframe and subsequent ones can be controlled. The value is latched and transmitted until a new value is set.

M4W **write** Address: 6A_H
Reset Value: BE_H

7	6	5	4	3	2	1	0
NIB	SAI	M46	CSO	NTM	PS2	PS1	ACT

NIB Network Indication Bit

0 = no function (reserved for network use)
1 = no function (reserved for network use)

SAI S Activity Indicator

0 = S-interface is deactivated
1 = S-interface is activated

CSO Cold Start Only

0 = NT is capable to perform warm starts
1 = NT activation with cold start only

Register Description

NEBE Near-End Block Error
 0 = Near-End Block Error has occurred
 1 = no Near-End Block Error has occurred

M61, M52, M51 Received Spare Bits of last U superframe (M51, M52 and M61 have no effect on the Q-SMINT®I).

FEBE Far-End Block Error
 0 = Far-End Block Error has occurred
 1 = no Far-End Block Error has occurred

4.11.10 M56W - M56 Write Register

Via the **M56** bit **Write** register, the M5 and M6 bits of the next available superframe can be set. The value is latched and transmitted as long as a new value is set or the function is disabled. The FEBE bit can only be set and controlled externally if OPMODE.FEBE is set to '1'.

M56W write Address: 6C_H

Reset Value: FF_H

7	6	5	4	3	2	1	0
1	1	1	1	M61	M52	M51	FEBE

M61, M52, M51 Transmitted Spare Bits to next U superframe (M51, M52 and M61 have no effect on the Q-SMINT®I).

FEBE Far-End Block Error
 0 = Far-End Block Error has occurred
 1 = no Far-End Block Error has occurred

4.11.11 UCIR - C/I Code Read Register

Via the **U**-transceiver **C/I** code **Read** register a microcontroller can access the C/I code that is output from the state machine.

Register Description

UCIR **read** Address: 6D_H

Reset Value: 00_H

7	6	5	4	3	2	1	0
0	0	0	0	C/I code output			

4.11.12 UCIW - C/I Code Write Register

The **U**-transceiver **C/I** code **Write** register allows a microcontroller to control the state of the U-transceiver. To enable this function bit UCI in register OPMODE must be set to '1' before.

UCIW **write** Address: 6E_H

Reset Value: 01_H

7	6	5	4	3	2	1	0
0	0	0	0	C/I code input			

4.11.13 TEST - Test Register

The **Test** register sets the U-transceiver in the desired test mode.

TEST **read*/write** Address: 6F_H

Reset Value: 00_H

7	6	5	4	3	2	1	0
0	0	0	0	CCRC	+1 tones	0	40kHz

- CCRC** Send Corrupt CRC
 0 = inactive
 1 = send corrupt (inverted) CRCs

- +1 tones** Send +/-1 Pulses Instead of +/-3
 0 = issues +/-3 pulses during 40 kHz tone generation or in SSP mode

Register Description

1 = issues +/-1 pulses

40kHz 40 kHz Test Signal

0 = issues single pulses in state 'Test'

1 = issues a 40 kHz test signal in state 'Test'

4.11.14 LOOP - Loop Back Register

The **Loop** register controls the digital loopbacks of the U-transceiver. The analog loopback (No. 3) is closed by C/I= 'ARL'.

Note: If the EOC automatic mode is selected (MFILT.EOC Filter = '100'), then register LOOP is accessed by the internal EOC processor:

EOC-command 'LB1' ('LB2') sets LOOP.U/IOM and LOOP.LB1 (LOOP.LB2)

EOC-command 'RTN' resets LOOP.LB1, LOOP.LB2 and LOOP.LBBD

LOOP read^{*)}/write Address: 70_H

Reset Value: 08_H

7	6	5	4	3	2	1	0
0	DLB	TRANS	U/IOM	1	LBBD	LB2	LB1

DLB Close Framer/Deframer Loopback

- the loopback is closed at the analog/digital interface
- prerequisite is that LB1, LB2, LBBD and U/IOM[®] are set to '0'
- only user data is looped and no maintenance data is looped back¹⁾

0 = Framer/Deframer loopback open

1 = Framer/Deframer loopback closed

TRANS Transparent/ Non-Transparent Loopback

- in transparent mode user data is both passed on and looped back, whereas in non-transparent mode data is not forwarded but substituted by '1's (idle code) and just looped back²⁾
- if LBBD, LB2, LB1 is closed towards the IOM[®] interface and bit TRANS is set to '0' then the state machine has to be put into state 'Transparent' first (e.g. by C/I = DT) before data is output on the U-interface
- bit TRANS has no effect on DLB and the analog loopback (ARL operates always in transparent mode)

Register Description

- 0 = sets transparent loop mode for LBBD, LB2, LB1
- 1 = sets non-transparent mode for LBBD, LB2, LB1
'1's are sent on the IOM[®]-2/PCM interface in the corresponding time-slot

- U/IOM** Close LBBD, LB2, LB1 Towards U or Towards IOM[®]
- Switch that selects whether loopback LB1, LB2 or LBBD is closed towards U or towards IOM[®]-2
 - the setting affects all test loops, LBBD, LB2 and LB1
 - an individual selection for LBBD, LB2, LB1 is not possible
- 0 = LB1, LB2, LBBD loops are closed from IOM[®]-2 to IOM[®]-2
 - 1 = LB1, LB2, LBBD loops are closed from U to U

- LBBD** Close Complete Loop (B1, B2, D) Near the System Interface
the direction towards the loop is closed is determined by bit 'U/IOM'
- 0 = complete loopback open
 - 1 = complete loopback closed

- LB2** Close Loop B2 Near the System Interface
the direction towards the loop is closed is determined by bit 'U/IOM'
- 0 = loopback B2 open
 - 1 = loopback B2 closed

- LB1** Close Loop B1 Near the System Interface
the direction towards the loop is closed is determined by bit 'U/IOM'
- 0 = loopback B1 open
 - 1 = loopback B1 closed

- 1) If in state Transparent the DLB-loopback is closed from IOM- to IOM, then C/I-code 'DC' instead of 'AI' is issued on the IOM[®]-2-interface.
- 2) If in state Transparent the non-transparent LBBD-loopback is closed from U- to U, then C/I-code 'DC' instead of 'AI' is issued on the IOM[®]-2-interface. However, the correct C/I-code 'AI' can be read from register UCIR.

4.11.15 FEBE - Far End Block Error Counter Register

The **Far End Block Error Counter Register** contains the FEBE value. If the register is read out it is automatically reset to '0'.

Register Description

FEBE read Address: 71_H

Reset Value: 00_H

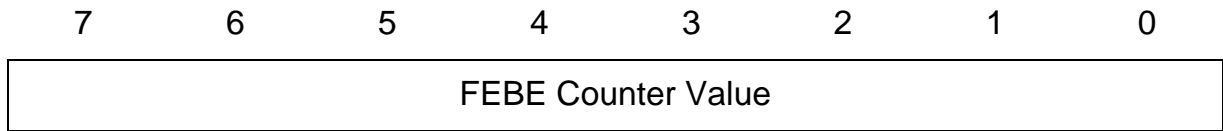

4.11.16 NEBE - Near End Block Error Counter Register

The **Near End Block Error Counter Register** contains the NEBE value. If the register is read out it is automatically reset to '0'.

NEBE read Address: 72_H

Reset Value: 00_H

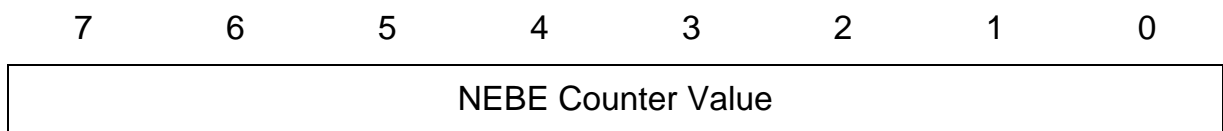

4.11.17 ISTAU - Interrupt Status Register U-Interface

The **Interrupt Status register U-interface** generates an interrupt for the unmasked interrupt flags. Refer to [Chapter 2.4.12](#) for details on masking and clearing of interrupt flags. For the timing of the interrupt flags ISTAU(3:0) refer to [Chapter 2.4.2.4](#).

ISTAU read Address: 7A_H

Reset Value: 00_H

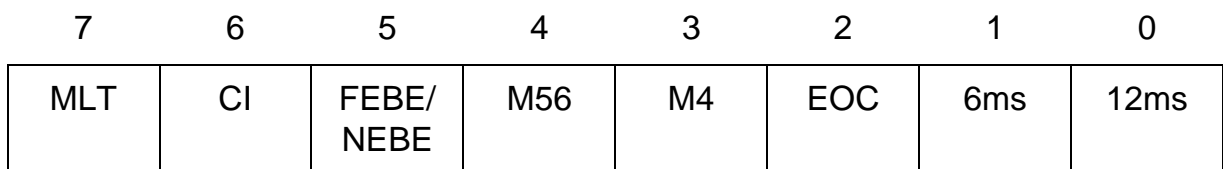

MLT MLT interrupt indication
 0 = inactive
 1 = MLT interrupt has occurred

Register Description

- CI** C/I code indication
the CI interrupt is generated independently on OPMODE.UCI
0 = inactive
1 = CI code change has occurred
- FEBE/NEBE** Far End/Near End Block Error indication
register M56R notifies whether a FEBE or NEBE has been detected
0 = inactive
1 = FEBE/NEBE occurred
- M56** Validated new M56 bit data received from U-interface
0 = inactive
1 = change of any M5, M6 bit has been detected in receive direction
- M4** Validated new M4 bit data received from U-interface
0 = inactive
1 = change of any M4 bit has been detected in receive direction
- EOC** Validated new EOC data received from U-interface
0 = inactive
1 = new EOC message has been received and acknowledged from U
- 6 ms** 6 ms timer for the transmission of EOC commands on U
0 = inactive
1 = indicates when a EOC command is going to be issued on U
- 12 ms** Superframe marker (each 12 ms) is going to be issued on U in transmit direction
Bellcore test requirement: SR-NWT-002397
0 = inactive
1 = indicates when a SF marker is going to be transmitted on U

4.11.18 MASKU - Mask Register U-Interface

The Interrupt **Mask** register **U-Interface** selectively masks each interrupt source in the ISTAU register by setting the corresponding bit to '1'.

Register Description

MASKU

read^{*)}/write

Address: 7B_H

Reset Value: FF_H

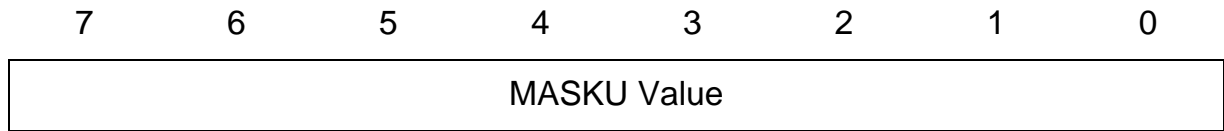

Bit 0..7 Mask bits

0 = interrupt active

1 = interrupt masked

4.11.19 FW_VERSION

FW_VERSION Register contains the Firmware Version number

FW_VERSION

read

Address: 7D_H

Reset value: 6x_H

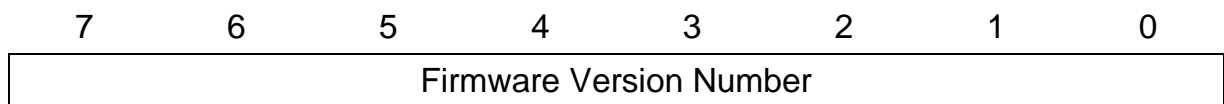

Version 1.2 : 6D_H

Version 1.3 : 6C_H

Electrical Characteristics

5 Electrical Characteristics

5.1 Absolute Maximum Ratings

Parameter	Symbol	Limit Values	Unit
Ambient temperature under bias	T_A	-40 to 85	°C
Storage temperature	T_{STG}	- 65 to 150	°C
Maximum Voltage on V_{DD}	V_{DD}	4.2	V
Maximum Voltage on any pin with respect to ground	V_S	-0.3 to $V_{DD} + 3.3$ (max. < 5.5)	V

ESD integrity (according EIA/JESD22-A114B (HBM)): 2 kV

Note: Stress above those listed here may cause permanent damage to the device. Exposure to absolute maximum ratings conditions for extended periods may affect device reliability.

Line Overload Protection

The Q-SMINT[®]I is compliant to ESD tests according to ANSI / EOS / ESD-S 5.1-1993 (CDM), EIA/JESD22-A114B (HBM) and to Latch-up tests according to JEDEC EIA / JESD78. From these tests the following max. input currents are derived ([Table 36](#)):

Table 36 Maximum Input Currents

Test	Pulse Width	Current	Remarks
ESD	100 ns	1.3 A	3 repetitions
Latch-up	5 ms	+/-200 mA	2 repetitions, respectively
DC	--	10 mA	

Electrical Characteristics
5.2 DC Characteristics
 $V_{DD}/V_{DDA} = 3.3 \text{ V} \pm 5\% ; V_{SS}/V_{SSA} = 0 \text{ V}; T_A = -40 \text{ to } 85 \text{ }^\circ\text{C}$

Digital Pins	Parameter	Symbol	Limit Values		Unit	Test Condition
			min.	max.		
All	Input low voltage	V_{IL}	-0.3	0.8	V	
	Input high voltage	V_{IH}	2.0	5.25	V	
All except DD/DU ACT, LP2I MCLK	Output low voltage	V_{OL1}		0.45	V	$I_{OL1} = 3.0 \text{ mA}$
	Output high voltage	V_{OH1}	2.4		V	$I_{OH1} = 3.0 \text{ mA}$
DD/DU ACT, LP2I MCLK	Output low voltage	V_{OL2}		0.45	V	$I_{OL2} = 4.0 \text{ mA}$
	Output high voltage (DD/DU push-pull)	V_{OH2}	2.4		V	$I_{OH2} = 4.0 \text{ mA}$
All	Input leakage current	I_{LI}		10	μA	$0 \text{ V} \leq V_{IN} \leq V_{DD}$
	Output leakage current	I_{LO}		10	μA	$0 \text{ V} \leq V_{IN} \leq V_{DD}$
Analog Pins						
AIN, BIN	Input leakage current	I_{LI}		70	μA	$0 \text{ V} \leq V_{IN} \leq V_D$ D

Table 37 S-Transceiver Characteristics

Pin	Parameter	Symbol	Limit Values			Unit	Test Condition
			min.	typ.	max.		
SX1,2	Absolute value of output pulse amplitude ($V_{SX2} - V_{SX1}$)	V_X	2.03	2.2	2.31	V	$R_L = 50 \Omega$
SX1,2	S-Transmitter output impedance	Z_X	10	34		k Ω	see ¹⁾
			0				see ²⁾³⁾
SR1,2	S-Receiver input impedance	Z_R	10 100			k Ω Ω	$V_{DD} = 3.3 \text{ V}$ $V_{DD} = 0 \text{ V}$

¹⁾ Requirement ITU-T I.430, chapter 8.5.1.1a): 'At all times except when transmitting a binary zero, the output impedance, in the frequency range of 2kHz to 1 MHz, shall exceed the impedance indicated by the template in Figure 11. The requirement is applicable with an applied sinusoidal voltage of 100 mV (r.m.s value)'

Electrical Characteristics

- 2) Requirement ITU-T I.430, chapter 8.5.1.1b): 'When transmitting a binary zero, the output impedance shall be $> 20 \Omega$.'; Must be met by external circuitry.
- 3) Requirement ITU-T I.430, chapter 8.5.1.1b), Note: 'The output impedance limit shall apply for a nominal load impedance (resistive) of 50Ω . The output impedance for each nominal load shall be defined by determining the peak pulse amplitude for loads equal to the nominal value $\pm 10\%$. The peak amplitude shall be defined as the the amplitude at the midpoint of a pulse. The limitation applies for pulses of both polarities.'

Table 38 U-Transceiver Characteristics

	Limit Values			Unit
	min.	typ.	max.	
Receive Path				
Signal / (noise + total harmonic distortion) ¹⁾	65 ²⁾			dB
DC-level at AD-output	45	50	55	% ³⁾
Threshold of level detect (measured between AIN and BIN with respect to zero signal)	4	5	16 (PEF 82912)	mV peak
			9 (PEF 82913)	
Input impedance AIN/BIN	80			k Ω
Transmit Path				
Signal / (noise + total harmonic distortion) ⁴⁾	70			dB
Common mode DC-level	1.61	1.65	1.69	V
Offset between AOUT and BOUT			35	mV
Absolute peak voltage for a single +3 or -3 pulse measured between AOUT and BOUT ⁵⁾	2.42	2.5	2.58	V
Output impedance AOUT/BOUT:				
Power-up		0.8	1.5	Ω
Power-down		3	6	Ω

1) Test conditions: 1.4 Vpp differential sine wave as input on AIN/BIN with long range (low, critical range).

2) Versions PEF 8x913 with enhanced performance of the U-interface are tested with tightened limit values

3) The percentage of the "1"-values in the PDM-signal.

4) Interpretation and test conditions: The sum of noise and total harmonic distortion, weighted with a low pass filter 0 to 80 kHz, is at least 70 dB below the signal for an evenly distributed but otherwise random sequence of +3, +1, -1, -3.

5) The signal amplitude measured over a period of 1 min. varies less than 1%.

Electrical Characteristics

5.3 Capacitances

$T_A = 25\text{ }^\circ\text{C}$, $3.3\text{ V} \pm 5\%$ $V_{SSA} = 0\text{ V}$, $V_{SSD} = 0\text{ V}$, $f_c = 1\text{ MHz}$, unmeasured pins grounded.

Table 39 Pin Capacitances

Parameter	Symbol	Limit Values		Unit	Remarks
		min.	max.		
Digital pads: Input Capacitance	C_{IN}		7	pF	
I/O Capacitance	$C_{I/O}$		7	pF	
Analog pads: Load Capacitance	C_L		3	pF	pin AIN, BIN

5.4 Power Consumption

Power Consumption

$V_{DD}=3.3\text{ V}$, $V_{SS}=0\text{ V}$, Inputs at V_{SS}/V_{DD} , no LED connected, 50% bin. zeros, no output loads except SX1,2 ($50\text{ }\Omega^1$)

Parameter	Limit Values			Unit	Test Condition
	min.	typ.	max.		
Operational U and S enabled, IOM [®] -2 off		235		mW	U: ETSI loop 1 (0 m)
		200		mW	U: ETSI Loop 2.(typical line)
Power Down		15		mW	

¹⁾ $50\text{ }\Omega$ ($2 \times TR$) on the S-bus.

5.5 Supply Voltages

$V_{DD_D} = + V_{dd} \pm 5\%$

$V_{DD_A} = + V_{dd} \pm 5\%$

The maximum sinusoidal ripple on VDD is specified in the following figure:

Electrical Characteristics

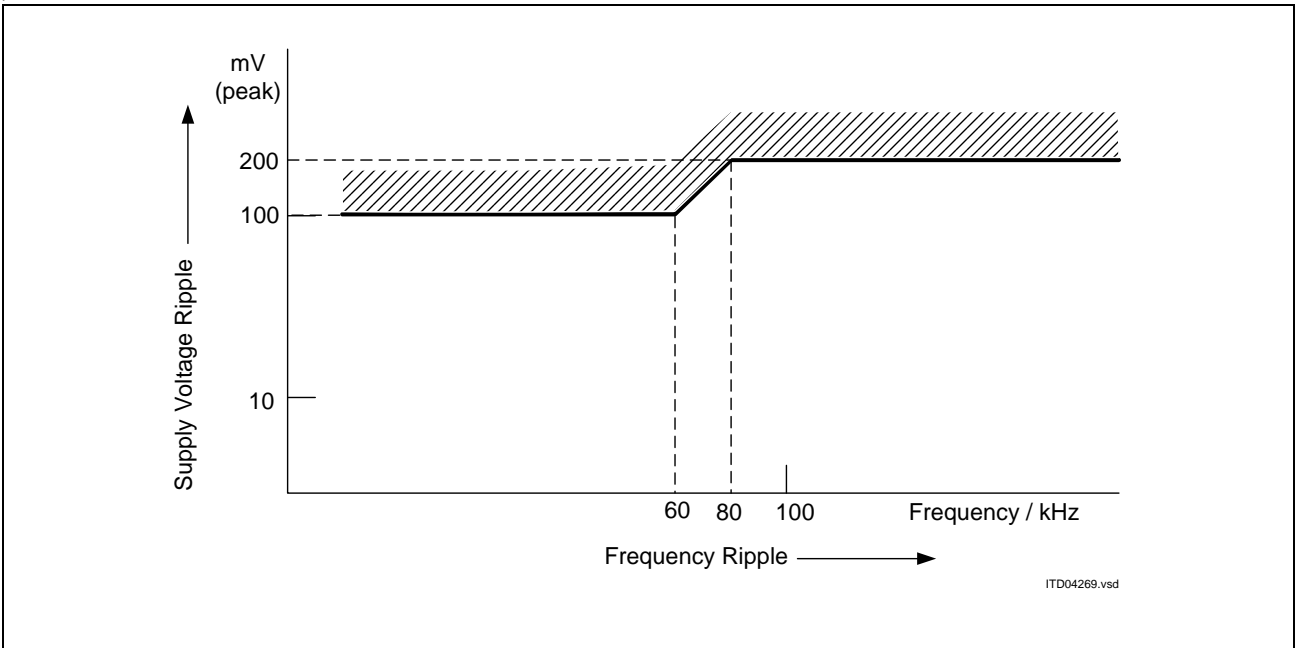

Figure 74 Maximum Sinusoidal Ripple on Supply Voltage

Electrical Characteristics

5.6 AC Characteristics

$T_A = -40$ to $85\text{ }^\circ\text{C}$, $V_{DD} = 3.3\text{ V} \pm 5\%$

Inputs are driven to 2.4 V for a logical "1" and to 0.4 V for a logical "0". Timing measurements are made at 2.0 V for a logical "1" and 0.8 V for a logical "0". The AC testing input/output waveforms are shown in **Figure 75**.

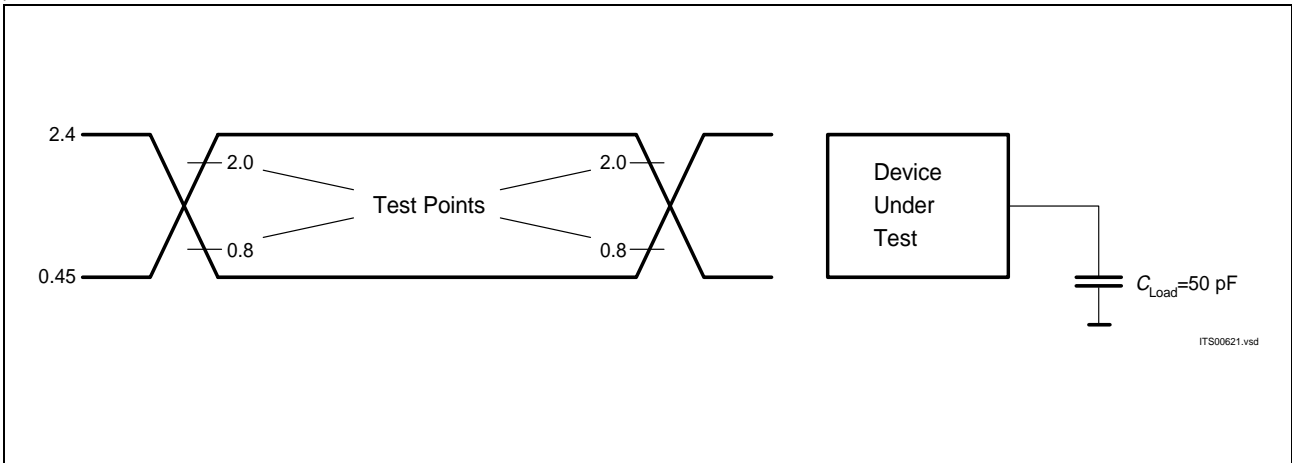

Figure 75 Input/Output Waveform for AC Tests

Parameter	Symbol	Limit values		Unit
		Min	Max	
All Output Pins				
Fall time			30	ns
Rise time			30	ns

Electrical Characteristics

5.6.1 IOM[®]-2 Interface

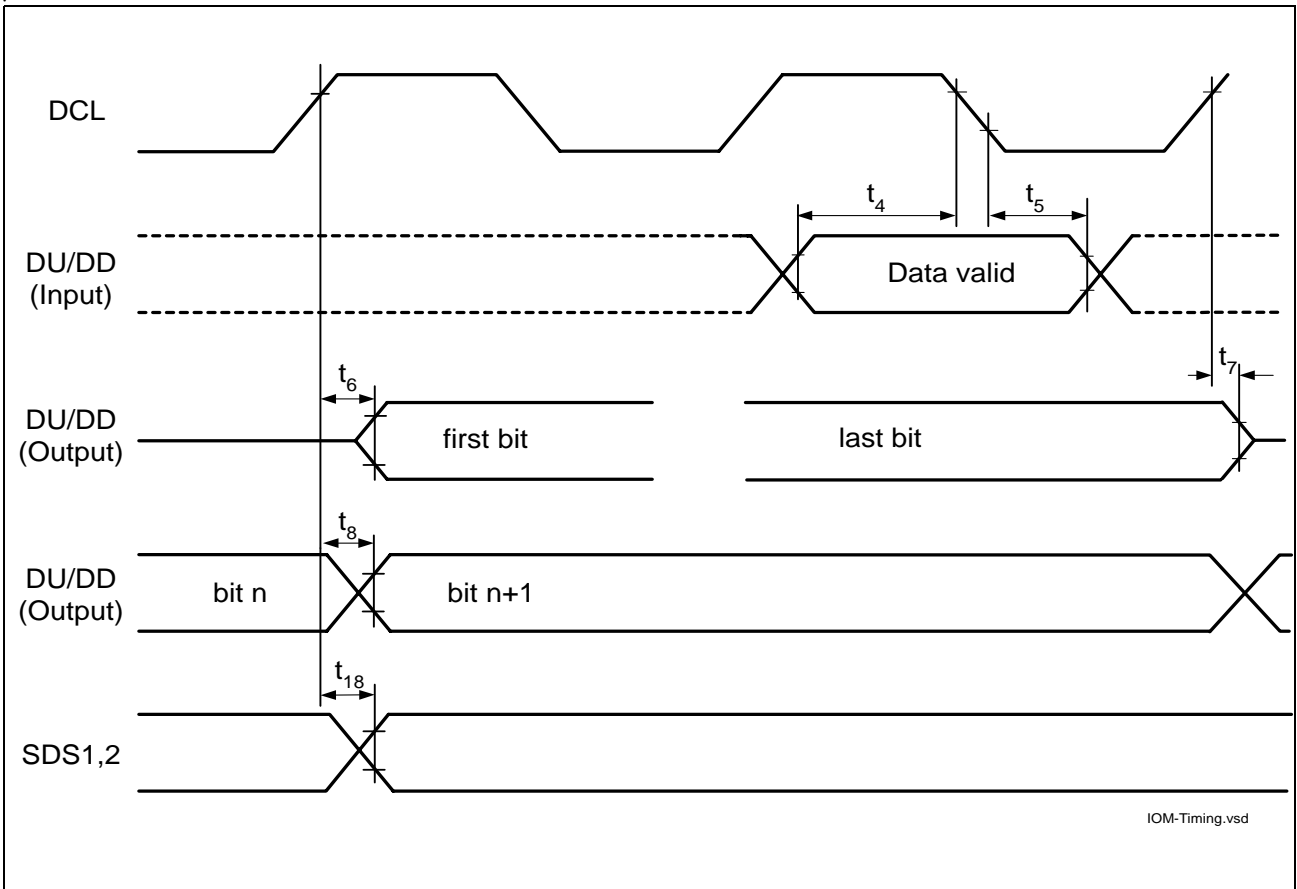

Figure 76 IOM[®]-2 Interface - Bit Synchronization Timing

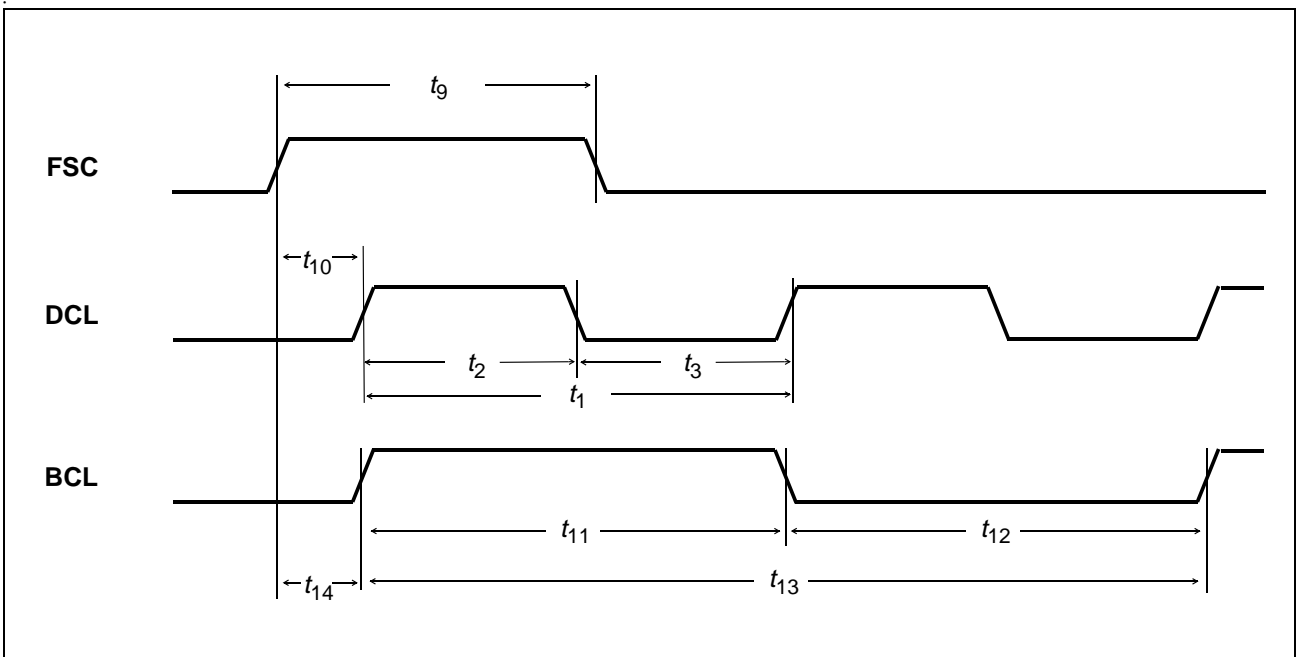

Figure 77 IOM[®]-2 Interface - Frame Synchronization Timing

Electrical Characteristics

Parameter IOM [®] -2 Interface	Symbol	Limit values			Unit
		Min	Typ	Max	
DCL period	t_1	565	651	735	ns
DCL high	t_2	200	310	420	ns
DCL low	t_3	200	310	420	ns
Input data setup	t_4	20			ns
Input data hold	t_5	20			ns
Output data from high impedance to active (FSC high or other than first timeslot)	t_6			100	ns
Output data from active to high impedance	t_7			100	ns
Output data delay from clock	t_8			80	ns
FSC high	t_9		50% of FSC cycle time		ns
FSC advance to DCL	t_{10}	65	130	195	ns
BCL high	t_{11}	565	651	735	ns
BCL low	t_{12}	565	651	735	ns
BCL period	t_{13}	1130	1302	1470	ns
FSC advance to BCL	t_{14}	65	130	195	ns
DCL, FSC rise/fall	t_{15}			30	ns
Data out fall ($C_L = 50$ pF, $R = 2$ k Ω to V_{DD} , open drain)	t_{16}			200	ns
Data out rise/fall ($C_L = 50$ pF, tristate)	t_{17}			150	ns
Strobe Signal Delay	t_{18}			120	ns

Note: At the start and end of a reset period, a frame jump may occur. This results in a DCL, BCL and FSC high time of min. 130 ns after this specific event.

Electrical Characteristics

5.6.2 Serial μ P Interface

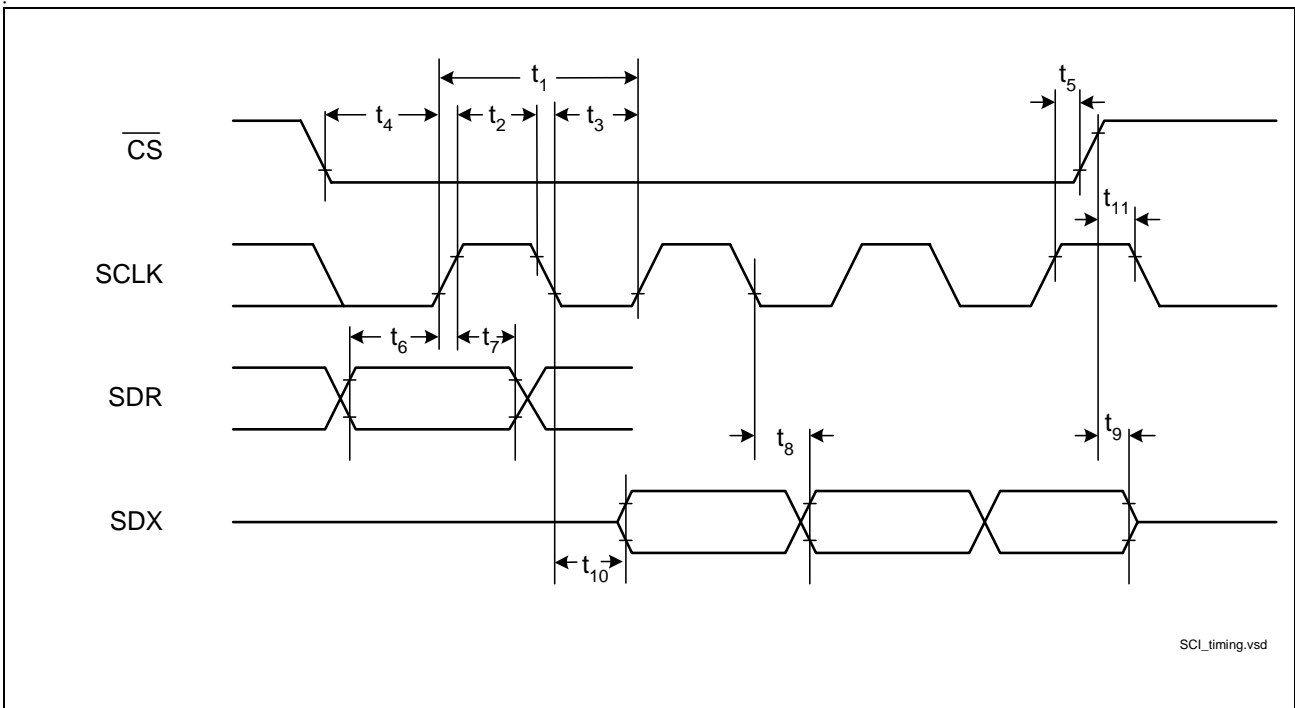

Figure 78 Serial Control Interface

Parameter SCI Interface	Symbol	Limit values		Unit
		Min	Max	
SCLK cycle time	t_1	200		ns
SCLK high time	t_2	80		ns
SCLK low time	t_3	80		ns
$\overline{\text{CS}}$ setup time	t_4	20		ns
$\overline{\text{CS}}$ hold time	t_5	10		ns
SDR setup time	t_6	15		ns
SDR hold time	t_7	15		ns
SDX data out delay	t_8		60	ns
$\overline{\text{CS}}$ high to SDX tristate	t_9		40	ns
SCLK to SDX active	t_{10}		60	ns
$\overline{\text{CS}}$ high to SCLK	t_{11}	10		ns

Electrical Characteristics

5.6.3 Parallel μ P Interface

Siemens/Intel Bus Mode

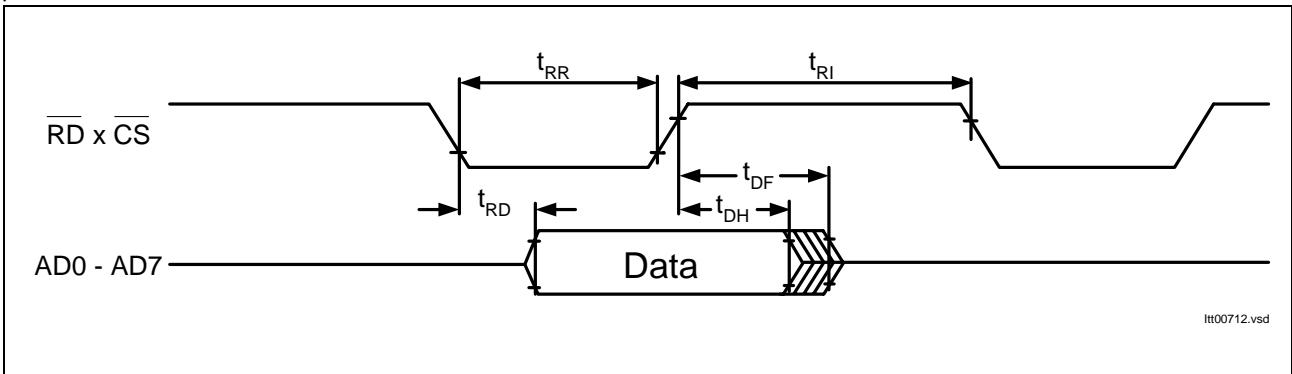

Figure 79 Microprocessor Read Cycle

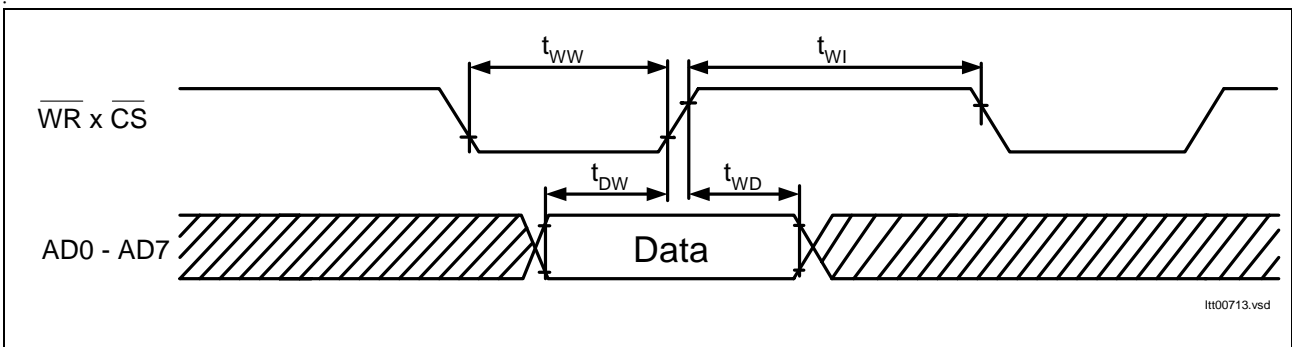

Figure 80 Microprocessor Write Cycle

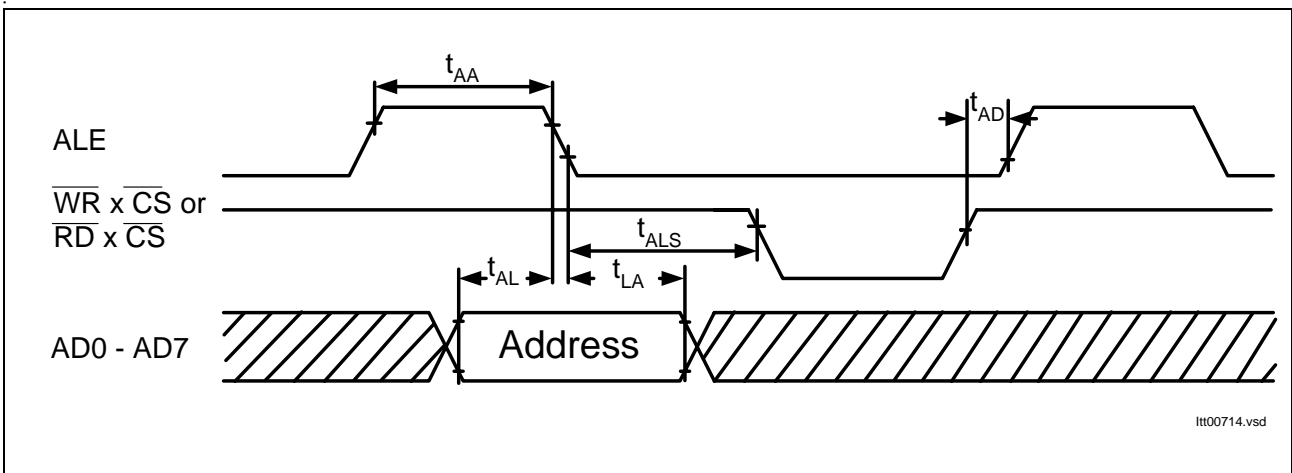

Figure 81 Multiplexed Address Timing

Electrical Characteristics

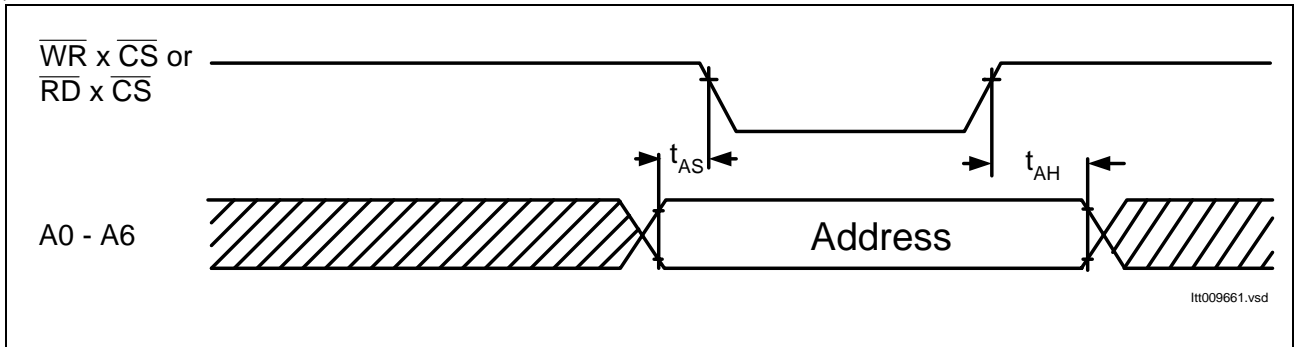

Figure 82 Non-Multiplexed Address Timing

Motorola Bus Mode

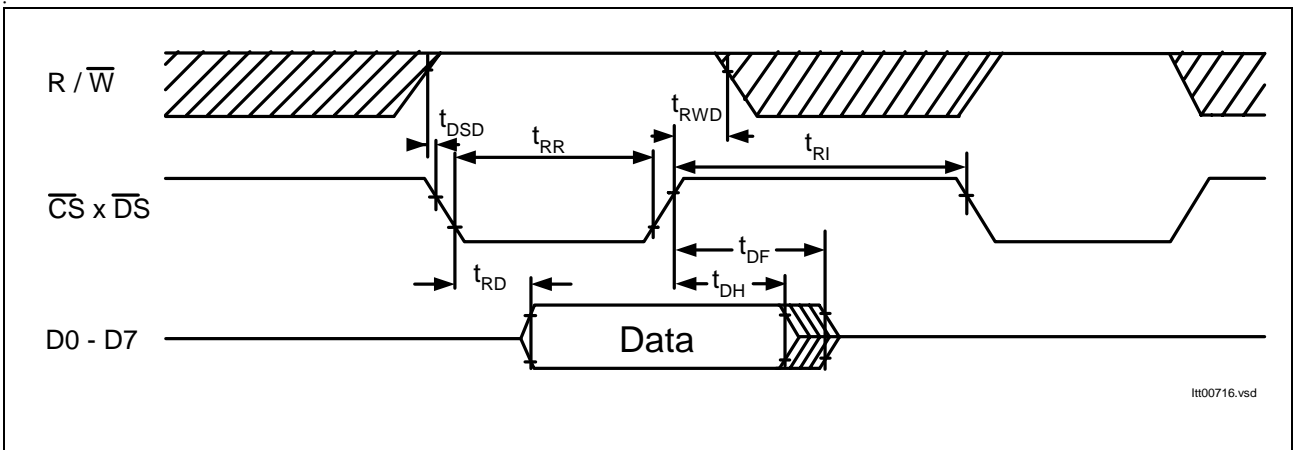

Figure 83 Microprocessor Read Timing

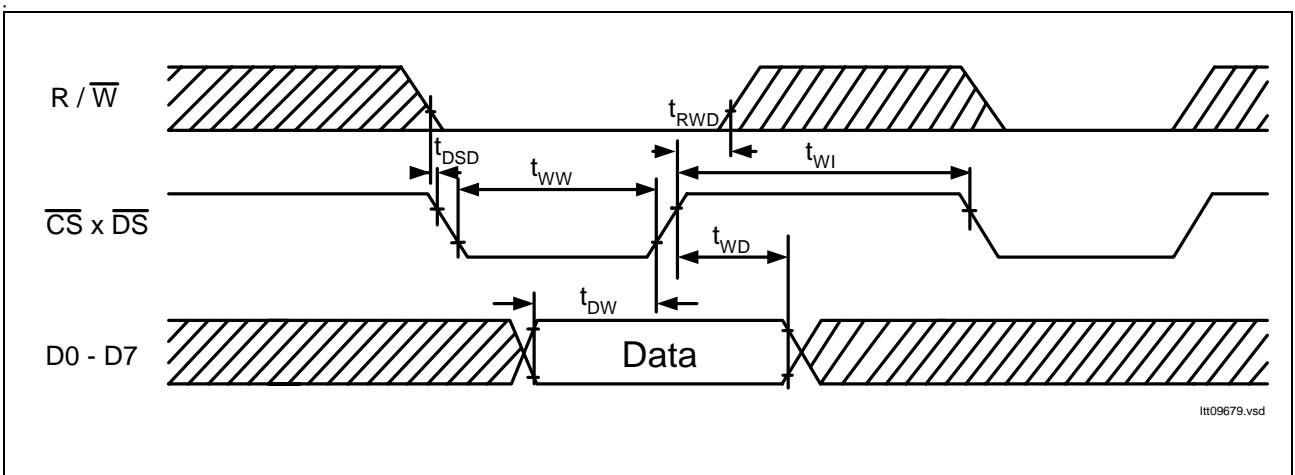

Figure 84 Microprocessor Write Cycle

Electrical Characteristics

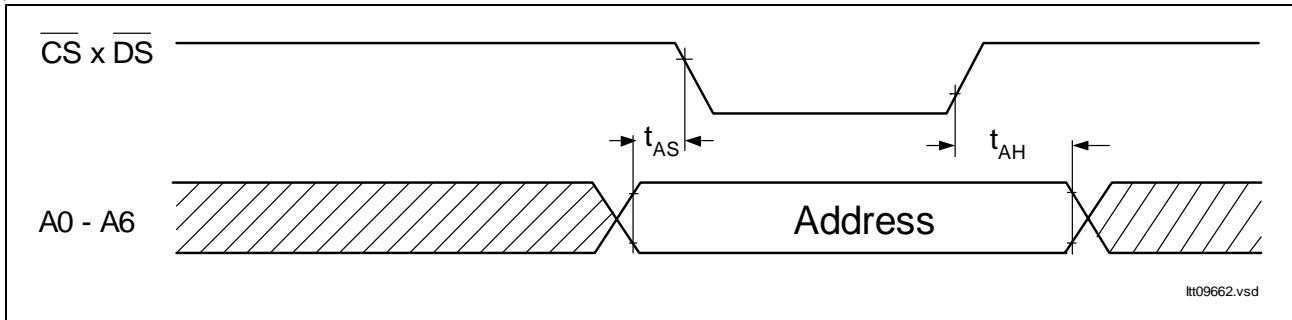

Figure 85 Non-Multiplexed Address Timing

Microprocessor Interface Timing

Parameter	Symbol	Limit Values		Unit
		min.	max.	
ALE pulse width	t_{AA}	20		ns
Address setup time to ALE	t_{AL}	10		ns
Address hold time from ALE	t_{LA}	10		ns
Address latch setup time to \overline{WR} , \overline{RD}	t_{ALS}	10		ns
Address setup time	t_{AS}	10		ns
Address hold time	t_{AH}	10		ns
ALE guard time	t_{AD}	10		ns
\overline{DS} delay after R/\overline{W} setup	t_{DSD}	10		ns
\overline{RD} pulse width	t_{RR}	80		ns
Data output delay from \overline{RD}	t_{RD}		80	ns
Data hold from \overline{RD}	t_{DH}	0		ns
Data float from \overline{RD}	t_{DF}		25	ns
\overline{RD} control interval ¹⁾	t_{RI}	70		ns
\overline{W} pulse width	t_{WW}	60		ns
Data setup time to $\overline{W} \times \overline{CS}$	t_{DW}	10		ns
Data hold time $\overline{W} \times \overline{CS}$	t_{WD}	10		ns
\overline{W} control interval	t_{WI}	70		ns
R/\overline{W} hold from $\overline{CS} \times \overline{DS}$ inactive	t_{RWD}	10		ns

¹⁾ control interval: t_{RI} is minimal 70ns for all registers except ISTAU, FEBE and NEBE. However, the time between two consecutive read accesses to one of the registers ISTAU, FEBE or NEBE, respectively, must be longer than 330ns. This does not limit t_{RI} of read sequences, which involve intermediate read access to other registers, as for instance: ISTAU -(t_{RI})- ISTA -(t_{RI})- ISTAH -(t_{RI})- ISTAU.

Electrical Characteristics

5.6.4 Reset

Table 40 Reset Input Signal Characteristics

Parameter	Symbol	Limit Values			Unit	Test Conditions
		min.	typ.	max.		
Length of active low state	$\overline{t_{RST}}$	4			ms	Power On the 4 ms are assumed to be long enough for the oscillator to run correctly
		2 x DCL clock cycles + 400 ns				After Power On
Delay time for μC access after \overline{RST} rising edge	$t_{\mu\text{C}}$	500			ns	

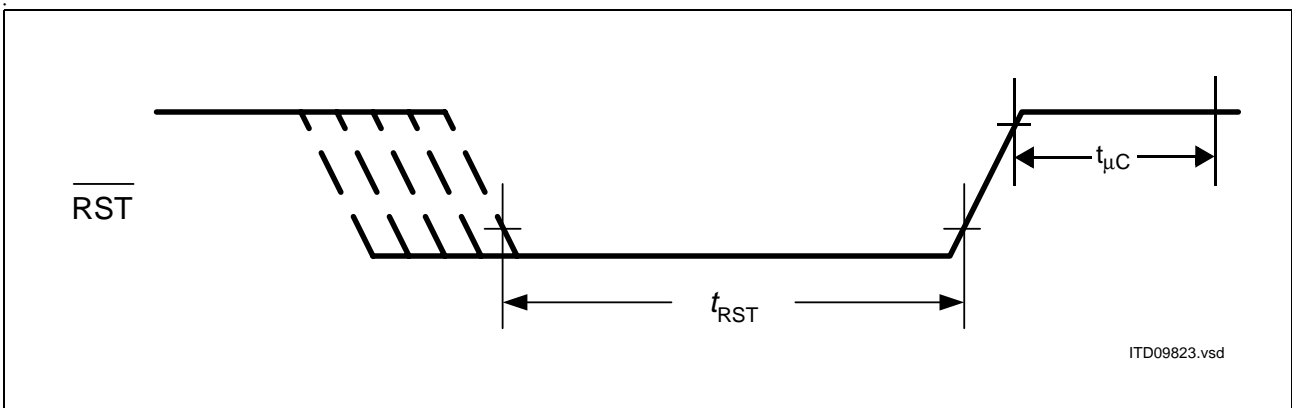

Figure 86 Reset Input Signal

Electrical Characteristics

5.6.5 Undervoltage Detection Characteristics

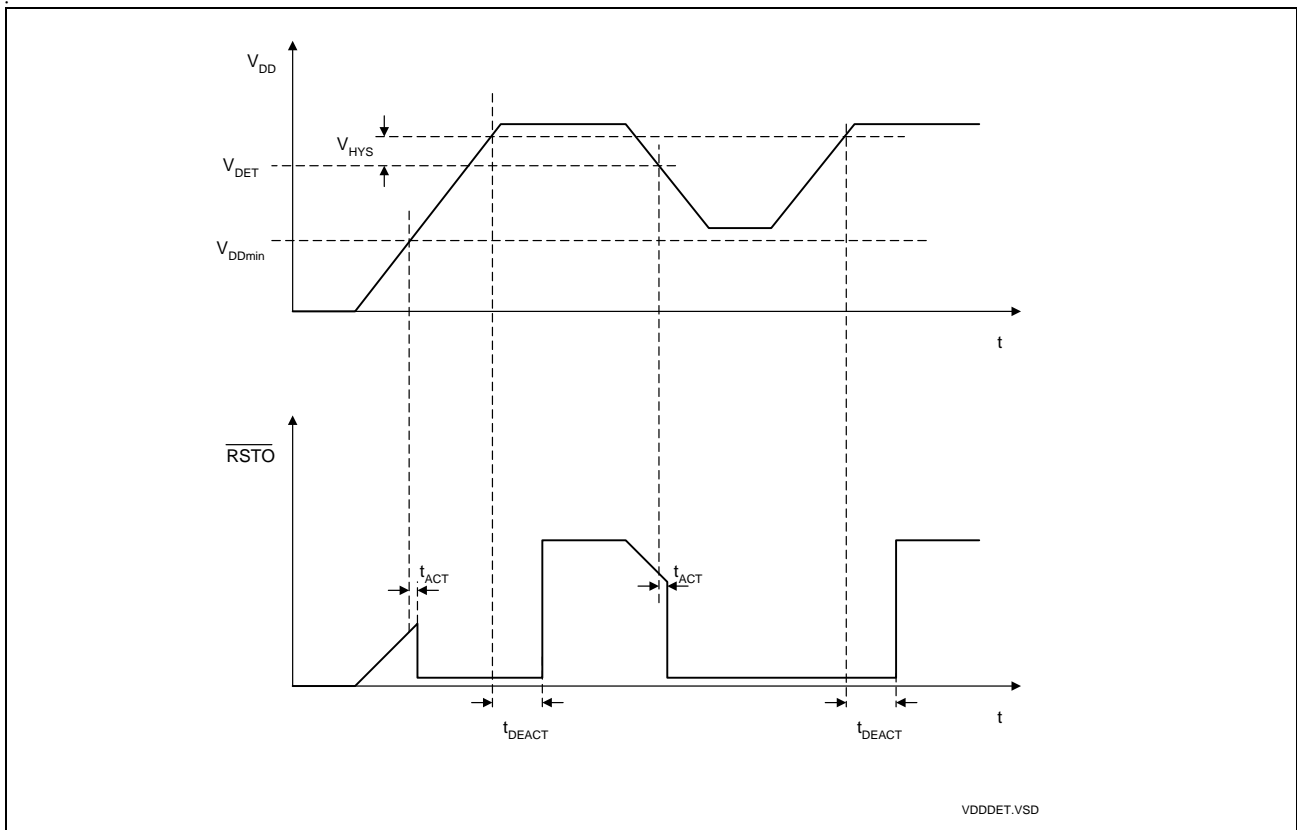

Figure 87 Undervoltage Control Timing

Table 41 Parameters of the UVD/POR Circuit

 $V_{DD} = 3.3 \text{ V} \pm 5 \%$; $V_{SS} = 0 \text{ V}$; $T_A = -40 \text{ to } 85 \text{ }^\circ\text{C}$

Parameter	Symbol	Limit Values			Unit	Test Condition
		min.	typ.	max.		
Detection Threshold ¹⁾	V_{DET}	2.7	2.8	2.92	V	$V_{DD} = 3.3 \text{ V} \pm 5 \%$
Hysteresis	V_{Hys}	30		90	mV	
Max. rising/falling V_{DD} edge for activation/deactivation of UVD	dV_{DD}/dt			0.1	V/ μs	
Max. rising V_{DD} for power-on ²⁾				0.1	V/ms	
Min. operating voltage	V_{DDmin}	1.5			V	

Electrical Characteristics

$V_{DD} = 3.3\text{ V} \pm 5\%$; $V_{SS} = 0\text{ V}$; $T_A = -40\text{ to }85\text{ }^\circ\text{C}$

Parameter	Symbol	Limit Values			Unit	Test Condition
		min.	typ.	max.		
Delay for activation of $\overline{\text{RSTO}}$	t_{ACT}			10	μs	
Delay for deactivation of $\overline{\text{RSTO}}$	t_{DEACT}		64		ms	

- 1) The Detection Threshold V_{DET} is far below the specified supply voltage range of analog and digital parts of the Q-SMINT[®]I. Therefore, the board designer must take into account that a range of voltages is existing, where neither performance and functionality of the Q-SMINT[®]I are guaranteed, nor a reset is generated.
- 2) If the integrated Power-On Reset of the Q-SMINTI is selected ($\overline{\text{VDDDET}} = '0'$) and the supply voltage V_{DD} is ramped up from 0V to 3.3V +/- 5%, then the Q-SMINTI is kept in reset during $V_{\text{DDmin}} < V_{\text{DD}} < V_{\text{DET}} + V_{\text{Hys}}$. V_{DD} must be ramped up so slowly that the Q-SMINTI leaves the reset state after the oscillator circuit has already finished start-up. The start-up time of the oscillator circuit is typically in the range between 3ms and 12ms.

6 Package Outlines

Plastic Package, P-MQFP-64
(Metric Quad Flat Package)

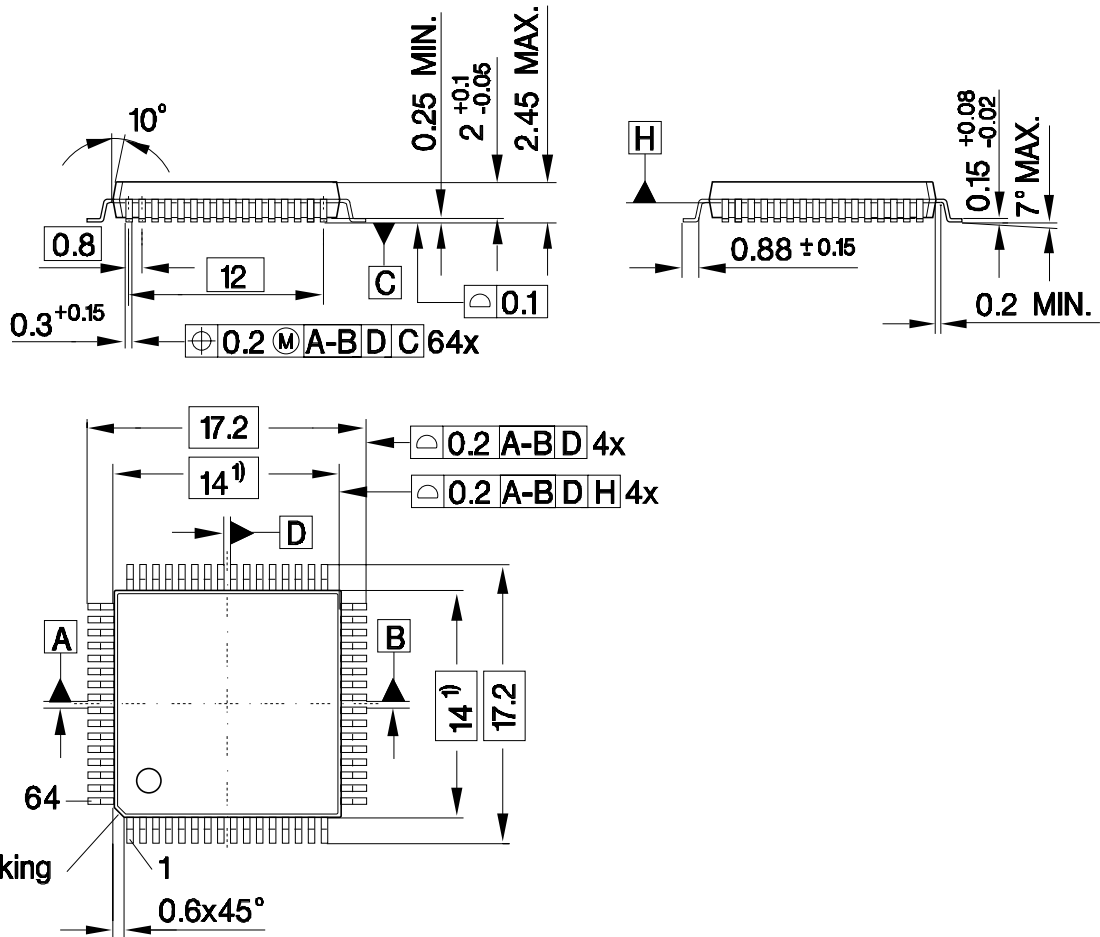

1) Does not include plastic or metal protrusion of 0.25 max. per side

Appendix: Differences between Q- and T-SMINT,I

7 Appendix: Differences between Q- and T-SMINT[®]I

The Q- and T-SMINT[®]I have been designed to be as compatible as possible. However, some differences between them are unavoidable due to the different line codes 2B1Q and 4B3T used for data transmission on the U_{k0} line.

Especially the pin compatibility between Q- and T-SMINT[®]I allows for one single PCB design for both series with only some mounting differences. The μ C software can distinguish between the Q- and T-series by reading the identification register via the IOM[®]-2 (MONITOR channel identification command) or the μ C interface (register ID.DESIGN), respectively.

The following chapter summarizes the main differences between the Q- and T-SMINT[®]I.

7.1 Pinning

Table 42 Pin Definitions and Functions

	Pin T/MQFP-64	Q-SMINT [®] I: 2B1Q	T-SMINT [®] I: 4B3T
	16	Metallic Termination Input (MTI)	Tie to '1'
	55	Power Status (primary) (PS1)	Tie to '1'
	41	Power Status (secondary) (PS2)	Tie to '1'

Appendix: Differences between Q- and T-SMINT,I

7.2 U-Transceiver

7.2.1 U-Interface Conformity

Table 43 Related Documents to the U-Interface

	Q-SMINT [®] I: 2B1Q	T-SMINT [®] I: 4B3T
ETSI: TS 102 080	conform to annex A compliant to 10 ms interruptions	conform to annex B
ANSI: T1.601-1998 (Revision of ANSI T1.601- 1992)	conform MLT input and decode logic	not required
CNET: ST/LAA/ELR/DNP/ 822	conform	not required
RC7355E	conform	not required
FTZ-Richtlinie 1 TR 220	not required	conform

Appendix: Differences between Q- and T-SMINT,I

7.2.2 U-Transceiver State Machines

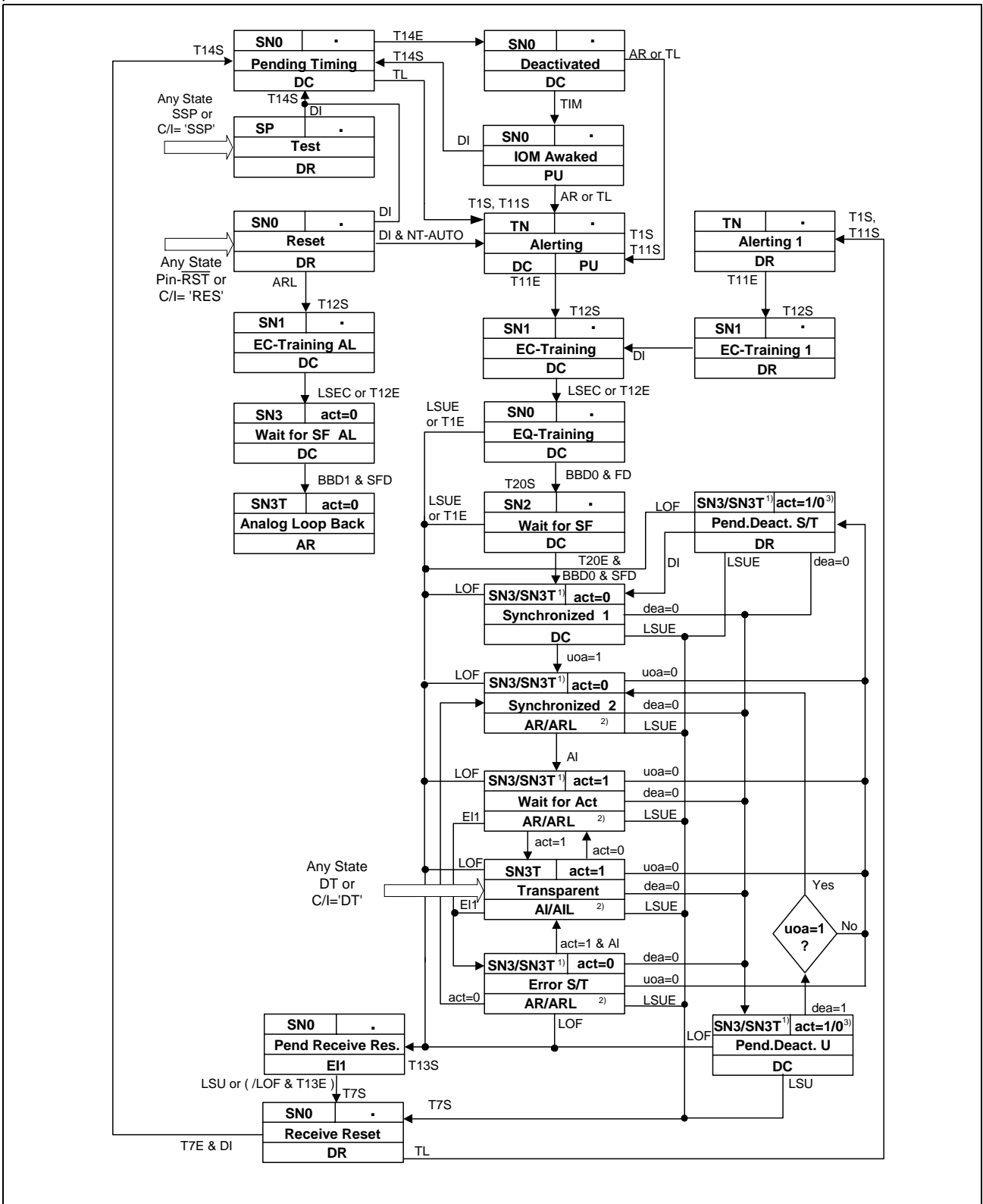

Figure 88 INTC-Q Compatible State Machine Q-SMINT® I: 2B1Q

Appendix: Differences between Q- and T-SMINT, I

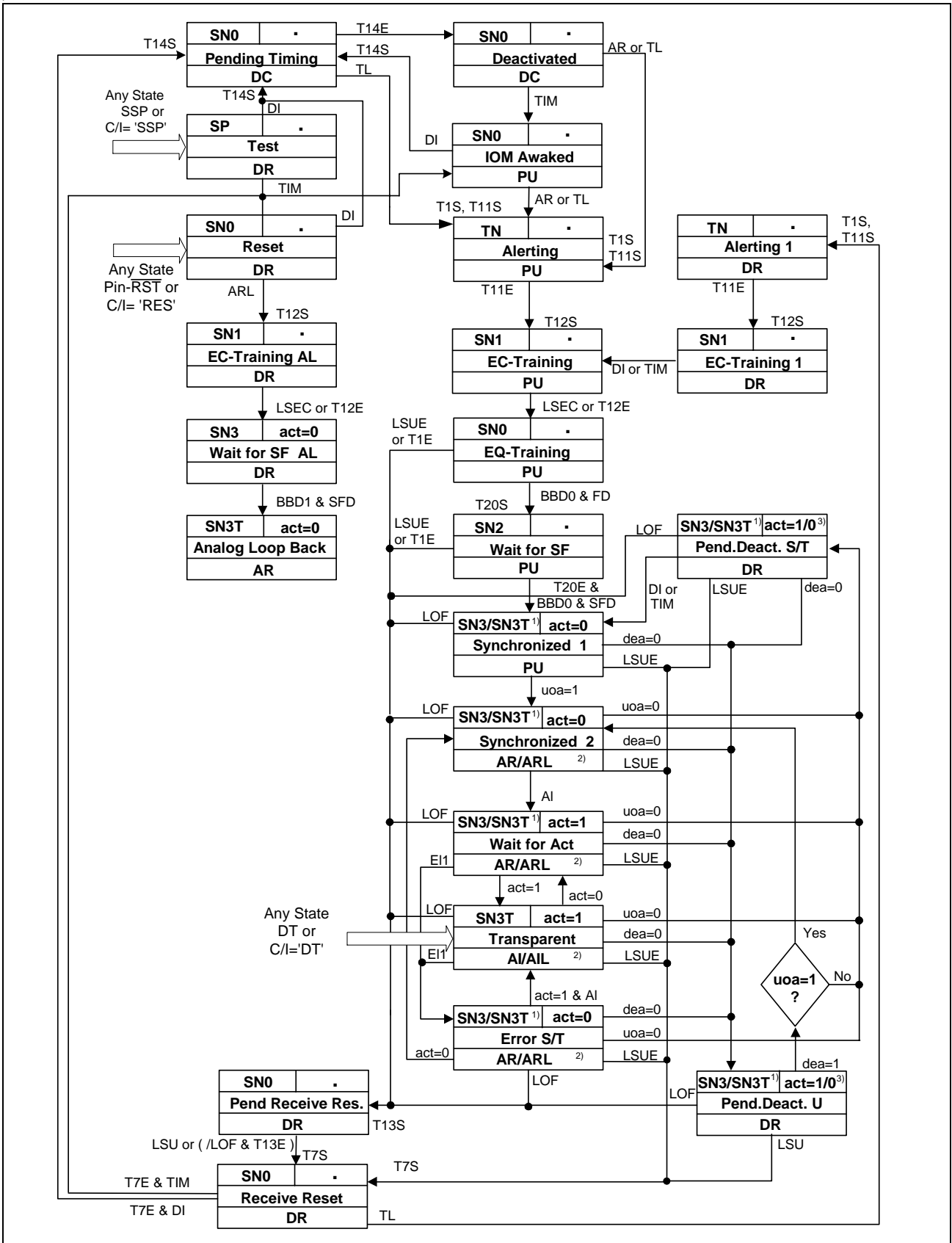
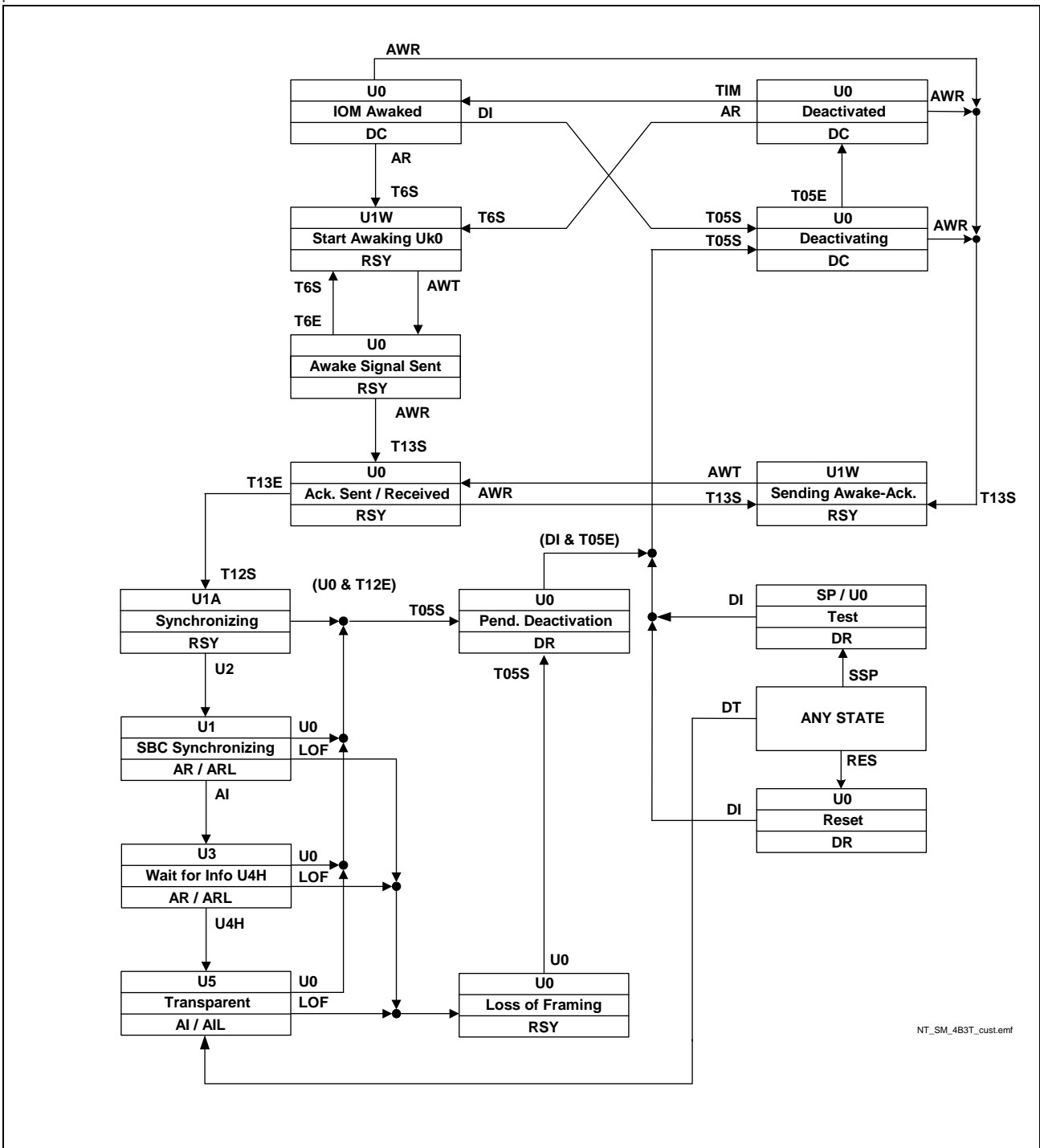

Figure 89 Simplified State Machine Q-SMINT® I: 2B1Q

Appendix: Differences between Q- and T-SMINT,I



NT_SM_4B3T_cust.emf

Figure 90 IEC-T/NTC-T Compatible State Machine T-SMINT®I: 4B3T

Both the Q- and the T-SMINT®I U-transceiver can be controlled via state machines, which are compatible to those defined for the old NT generation INTC-Q and NTC-T. Additionally, the Q-SMINT®I possesses a newly defined, so called ‘simplified’ state machine. This simplified state machine can be used optionally instead of the INTC-Q compatible state machine and eases the U-transceiver control by software. Such a simplified state machine is not available for the T-SMINT®I.

Appendix: Differences between Q- and T-SMINT,I

7.2.3 Command/Indication Codes

Table 44 C/I Codes

Code	Q-SMINT [®] I: 2B1Q		T-SMINT [®] I: 4B3T	
	IN	OUT	IN	OUT
0000	TIM	DR	TIM	DR
0001	RES	–	–	–
0010	–	–	–	–
0011	–	–	–	–
0100	EI1	EI1	–	RSY
0101	SSP	–	SSP	–
0110	DT	–	DT	–
0111	–	PU	–	–
1000	AR	AR	AR	AR
1001	–	–	–	–
1010	ARL	ARL	–	ARL
1011	–	–	–	–
1100	AI	AI	AI	AI
1101	–	–	RES	–
1110	–	AIL	–	AIL
1111	DI	DC	DI	DC

Appendix: Differences between Q- and T-SMINT,I

7.2.4 Interrupt Structure

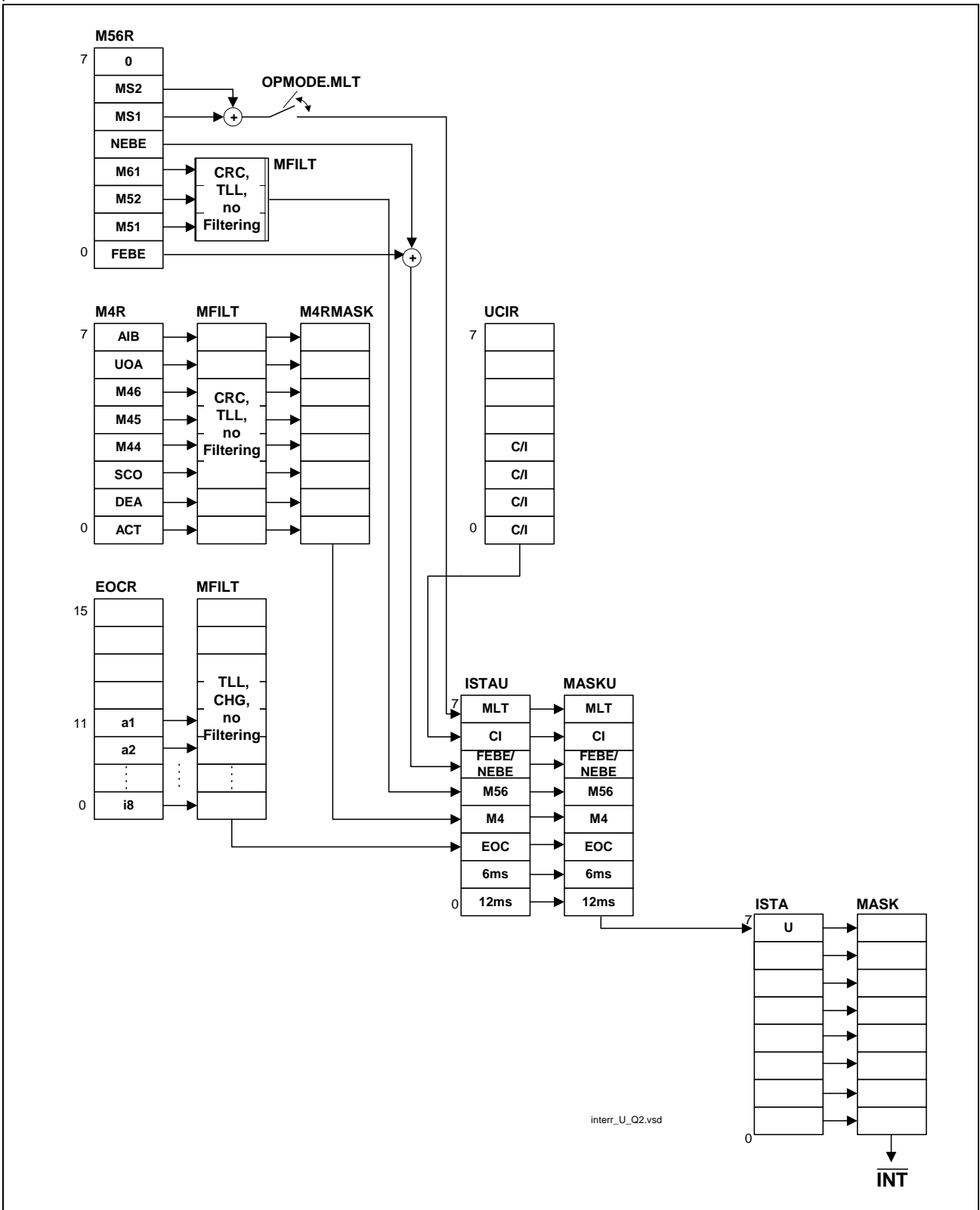

Figure 91 Interrupt Structure U-Transceiver Q-SMINT® I: 2B1Q

Appendix: Differences between Q- and T-SMINT,I

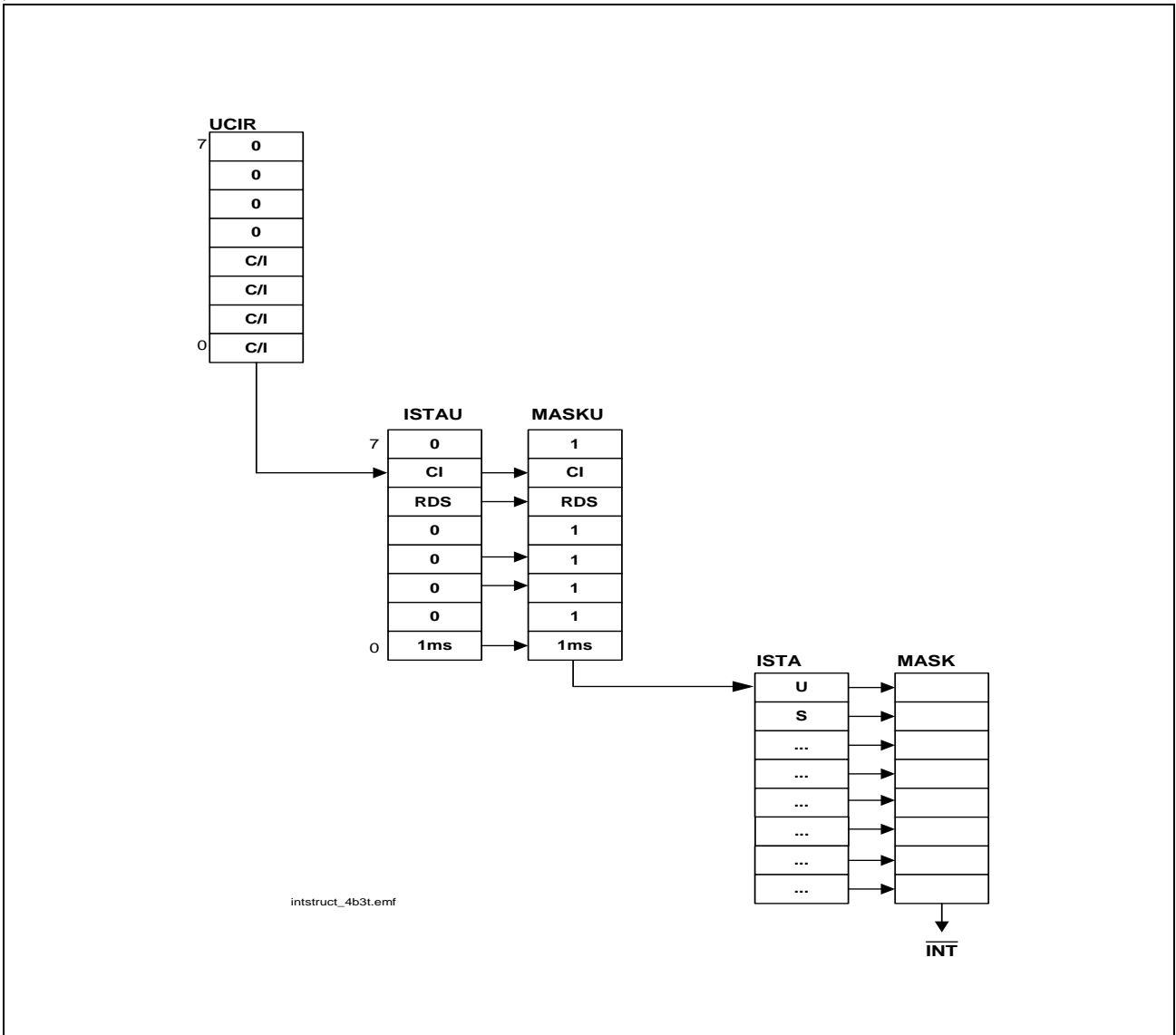

Figure 92 Interrupt Structure U-Transceiver T-SMINT[®]I: 4B3T

Appendix: Differences between Q- and T-SMINT,I

7.2.5 Register Summary U-Transceiver

U-Interface Registers Q-SMINT® I: 2B1Q

Name	7	6	5	4	3	2	1	0	ADDR	R/W	RES
OPMODE	0	UCI	FEBE	MLT	0	CI_SEL	0	0	60 _H	R*/W	14 _H
MFILT	M56 FILTER		M4 FILTER			EOC FILTER			61 _H	R*/W	14 _H
	reserved								62 _H		
EOCR	0	0	0	0	a1	a2	a3	d/m	63 _H	R	0F
	i1	i2	i3	i4	i5	i6	i7	i8	64 _H		FF _H
EOCW	0	0	0	0	a1	a2	a3	d/m	65 _H	W	01 _H
	i1	i2	i3	i4	i5	i6	i7	i8	66 _H		00 _H
M4RMASK	M4 Read Mask Bits								67 _H	R*/W	00 _H
M4WMASK	M4 Write Mask Bits								68 _H	R*/W	A8 _H
M4R	verified M4 bit data of last received superframe								69 _H	R	BE _H
M4W	M4 bit data to be send with next superframe								6A _H	R*/W	BE _H
M56R	0	MS2	MS1	NEBE	M61	M52	M51	FEBE	6B _H	R	1F _H
M56W	1	1	1	1	M61	M52	M51	FEBE	6C _H	W	FF _H
UCIR	0	0	0	0	C/I code output				6D _H	R	00 _H
UCIW	0	0	0	0	C/I code input				6E _H	W	01 _H
TEST	0	0	0	0	CCRC	+1 Tones	0	40 KHz	6F _H	R*/W	00 _H
LOOP	0	DLB	TRANS	U/IOM®	1	LBBD	LB2	LB1	70 _H	R*/W	08 _H
FEBE	FEBE Counter Value								71 _H	R	00 _H
NEBE	NEBE Counter Value								72 _H	R	00 _H
	reserved								73 _H - 79 _H		

Appendix: Differences between Q- and T-SMINT,I

Name	7	6	5	4	3	2	1	0	ADDR	R/W	RES
ISTAU	MLT	CI	FEBE/ NEBE	M56	M4	EOC	6ms	12ms	7A _H	R	00 _H
MASKU	MLT	CI	FEBE/ NEBE	M56	M4	EOC	6ms	12ms	7B _H	R*/W	FF _H
	reserved								7C _H		
FW_ VERSION	FW Version Number								7D _H	R	6x _H
	reserved								7E _H 7F _H		

**Appendix: Differences between Q- and T-SMINT, I
U-Interface Registers T-SMINT[®]I: 4B3T**

Name	7	6	5	4	3	2	1	0	ADDR	R/W	RES
OPMODE	0	UCI	0	0	0	0	0	0	60 _H	R*/W	00 _H
	reserved								61 _H - 6C _H		
UCIR	0	0	0	0	C/I code output				6D _H	R	00 _H
UCIW	0	0	0	0	C/I code input				6E _H	W	01 _H
	reserved								6F _H		
LOOP	0	DLB	TRANSU/IOM [®]	1	LBBD	LB2	LB1		70 _H	R*/W	08 _H
	reserved								71 _H		
RDS	Block Error Counter Value								72 _H	R	00 _H
	reserved								73 _H - 79 _H		
ISTAU	0	CI	RDS	0	0	0	0	1 ms	7A _H	R	00 _H
MASKU	1	CI	RDS	1	1	1	1	1 ms	7B _H	R*/W	FF _H
	reserved								7C _H		
FW_ VERSION	FW Version Number								7D _H	R	3x _H
	reserved								7E _H - 7F _H		

Appendix: Differences between Q- and T-SMINT,I

7.3 External Circuitry

The external circuitry of the Q- and T-SMINT[®]I is equivalent; however, some external components of the U-transceiver hybrid must be dimensioned different for 2B1Q and 4B3T. All information on the external circuitry is preliminary and may be changed in future documents.

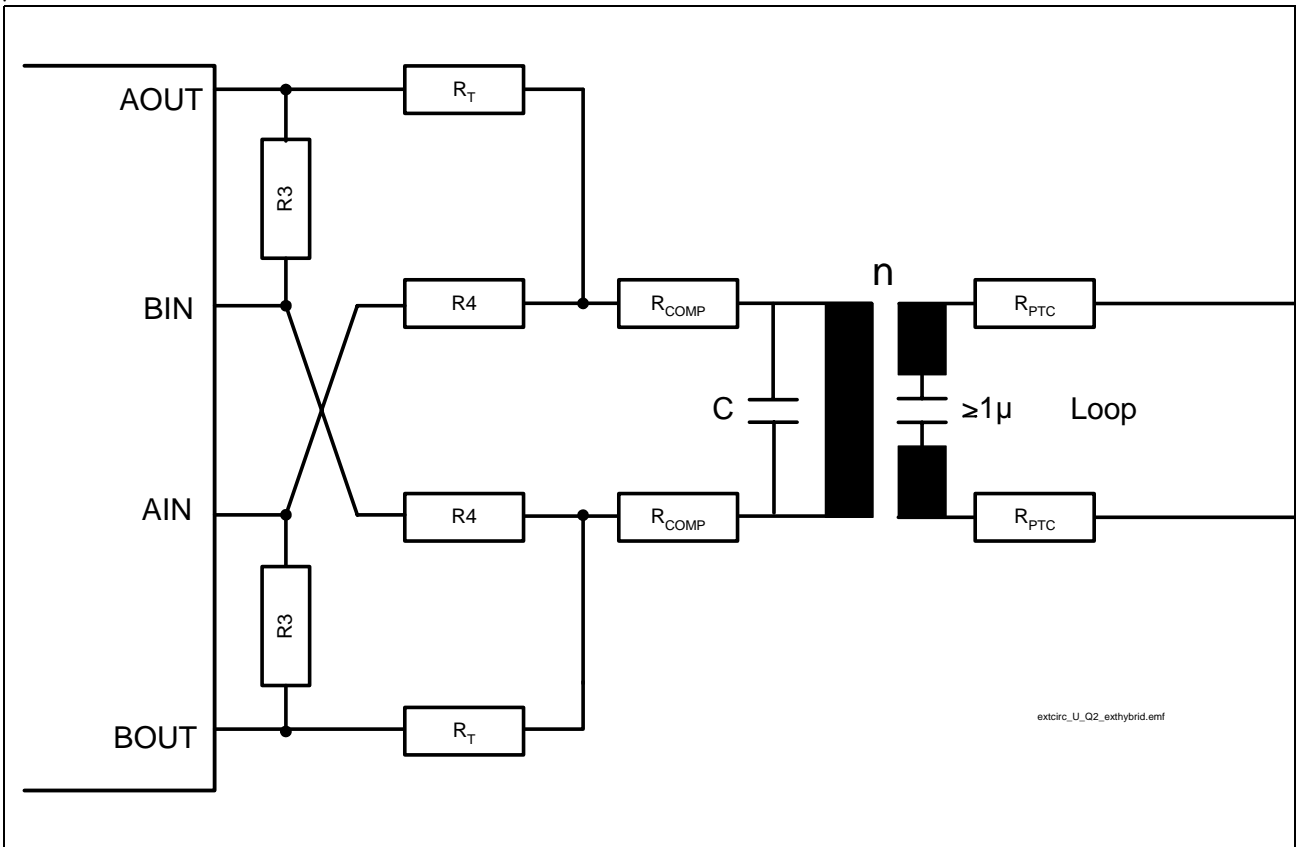

Figure 93 External Circuitry Q- and T-SMINT[®]I

Note: the necessary protection circuitry is not displayed in [Figure 93](#).

Appendix: Differences between Q- and T-SMINT,I

Table 45 **Dimensions of External Components**

Component	Q-SMINT® I: 2B1Q	T-SMINT® I: 4B3T
Transformer: Ratio	1:2	1:1.6
Main Inductivity	14.5 mH	7.5 mH
Resistance R3	1.3 kΩ	1.75 kΩ
Resistance R4	1.0 kΩ	1.0 kΩ
Resistance R _T	9.5 Ω	25 Ω
Capacitor C	27 nF	15 nF
R _{PTC} and R _{Comp}	$2R_{PTC} + 8R_{Comp} = 40 \Omega$	$n^2 \times (2R_{COMP} + R_B) + R_L = 20\Omega$

8 Index

A

Absolute Maximum Ratings 194
Address Space 136

B

Block Diagram 7
Block Error Counters 81

C

C/I Channel
 Detailed Registers 148
 Functional Description 50
C/I Codes
 S-Transceiver 109
 U-Transceiver 83
Controller Data Access (CDA) 31
Cyclic Redundancy Check 79

D

DC Characteristics 195
D-Channel Access Control
 Functional Description 52
 State Machine 56
Differences between Q- and T-SMINT 211

E

EOC 67
External Circuitry
 S-Transceiver 132
 U-Transceiver 130

F

Features 3

I

Identification
 via Monitor Channel 48
 via Register Access 164
Interrupts 137
IOM[®]-2 Interface

AC Characteristics 200
Activation/Deactivation 59
Detailed Registers 165
Frame Structure 28
Functional Description 28

L

Layer 1
 Activation/Deactivation 120
 Loopbacks 125
LED Pins 13
Line Overload Protection 194

M

Maintenance Channel 64
Metallic Loop Termination 99
Microcontroller Clock Generation 24
Microcontroller Interfaces
 Interface Selection 17
 Parallel Microcontroller Interface 22
 Serial Control Interface (SCI) 18
Monitor Channel
 Detailed Registers 176
 Error Treatment 46
 Functional Description 42
 Handshake Procedure 42
 Interrupt Logic 49
 Time-Out Procedure 49

O

Oscillator Circuitry 134
Overhead Bits 75

P

Package Outlines 209
Parallel Microcontroller Interface
 AC-Characteristics 203
 Functional Description 22
Pin Configuration 6
Pin Definitions and Functions 8
Power Consumption 197
Power Supply Blocking 130
Power-On Reset 27, 207

R

Register Summary 139

Reset

 Generation 25

 Input Signal Characteristics 206

 Power-On Reset 27, 207

 Under Voltage Detection 27, 207

S

S/Q Channels 105

Scrambling/ Descrambling 83

Serial Control Interface (SCI)

 AC-Characteristics 202

 Functional Description 18

Serial Data Strobe Signal 41

Stop/Go Bit Handling 54

S-Transceiver

 Detailed Registers 152

 Functional Description 103

 State Machine, LT-S 115

 State Machine, NT 111

Supply Voltages 197

Synchronous Transfer 37

System Integration 14

T

Test Modes 14

TIC Bus Handling 53

U

U-Interface Hybrid 130

Under Voltage Detection 27, 207

U-Transceiver

 Detailed Registers 179

 Functional Description 60

 State Machine, Simplified NT 95

 State Machine, Standard NT 87

W

Watchdog Timer 26

Infineon goes for Business Excellence

“Business excellence means intelligent approaches and clearly defined processes, which are both constantly under review and ultimately lead to good operating results.

Better operating results and business excellence mean less idleness and wastefulness for all of us, more professional success, more accurate information, a better overview and, thereby, less frustration and more satisfaction.”

Dr. Ulrich Schumacher

<http://www.infineon.com>

Published by Infineon Technologies AG

Looking for pricing, stock, or lifecycle information?

Click below to explore more details on WIN SOURCE:

-  [View PEF 80912 H V1.4 on WIN SOURCE](#)
-  [Infineon Technologies](#) Information

Optimize Your Supply Chain with WIN SOURCE Solutions

-  Global Sourcing Solution
-  Obsolete Management
-  Cost Control Management
-  Shortage Management
-  Alternative Solution
-  Excess Inventory Management