



# THE DATASHEET OF BPD1003



## Backplanes for the T Series

## BPD Series BPF Series

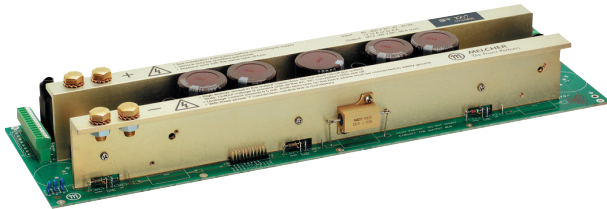

### Summary

The backplane types BPF 1000 and BPD 1000 have been designed for fast and simple set-up of 19" rack-mounted power supply systems powered by AC-DC converters of the T series. Battery charger systems, telecom rectifiers, and modular power bus systems can easily be configured with n+1 redundancy if required. Three T units can be plugged into one backplane providing up to 1.6 kW output power.

Since for such applications the status of the power bus is of importance rather than the output status of a single AC-DC converter, T units with option D should be chosen enabling remote bus voltage sensing.

The backplane concept allows quick system assembly. When fitted in the rack all input and output terminals are readily accessible from the rear. The AC input is designed for single or 3-phase operation. The monitoring signals and the control signal inputs and outputs are available from a screw terminal strip. System specific signal combination is possible with different jumper settings. The backplane fulfills in this way the function of a controller unit.

The layout of the backplane and the hot plug-in capability of the AC-DC converters allow system expansion under load (e.g. from 550 W up to 1.6 kW) by simply inserting further T units into the rack. Larger system power extension is just a matter of interlinking the DC output rails and signal

### 19"/3U Rack-Systems

- Easy configuration of telecom rectifiers, battery chargers and power bus systems
- Provides controller function
- 1.6 kW maximum power
- Single or triple phase connection
- Redundant configuration possible

outputs of two or more racks.

The backplanes are available in 2 basic versions:

- BPD 1000  
A front-end version, fitted with decoupling diodes in each positive line to the DC bus, for systems with 2 or more T units in parallel or n+1 redundancy.
- BPF 1000  
A battery charger version, in which each output is fitted with a fuse in the positive line to the DC bus, for battery charging or rectifier systems with two or more T units in parallel or n+1 redundancy.

For minimum electromagnetic emission at the input, both the BPD and the BPF versions are fitted with input filters. Should project specific requirements demand enhanced hold-up time or lower output ripple (low frequency ripple) than specified for the individual AC-DC converters, both basic backplane versions are available with additional output capacitors.

**Important:** The necessity to provide a cover over the live parts at the mains input (High Voltage) or over the DC bus bars (Energy Danger), preventing accidental contact during installation, start-up of a system, or maintenance depends on the final installation as well as on the applicable safety requirements. However, it is the responsibility of the installer or user to provide such a safety cover to assure the compliance with the relevant and applicable safety standards.

### Table of Contents

	Page		Page
Summary .....	1	Electromagnetic Compatibility (EMC) .....	7
Type Survey and Key Data .....	2	System Integration .....	8
Functional Description .....	2	Mechanical Data .....	10
Mains Input Section .....	4	Safety and Installation Instructions .....	10
Output Section .....	5		

## Type Survey and Key Data

Table 1: Type survey

AC Input 85...255 V AC 1 or 3 phase (Y)	Input filters <sup>1</sup>	Output capacitors (reduced 100 Hz output ripple) <sup>2</sup>	Preload	Application
BPD 1002 BPD 1003	x x	– 90 mF	– –	Front-end, fitted with diodes
BPF 1004 BPF 1007 BPF 1006	x x x	– 50 mF 90 mF	x x x	Battery charger, fitted with fuses
19" Rack, 3 U				Rack for systems with up to 3 T units

<sup>1</sup> See also: *Electromagnetic Compatibility*.

<sup>2</sup> Please refer to: *Dimensioning Example of a Battery Charger System in Single Phase Connection*

<sup>3</sup> Only for LT units and 120/208 V mains. See fig.: *Mains input arrangement*.

Model numbers highlighted in yellow or shaded are not recommended for new designs.

## Functional Description

The backplane is divided into 3 sections, each one fitted with an H15 female connector for one T unit, with the mains input section and the DC output section separated from each other.

The layout of the standard backplanes gives the user the flexibility to operate the system either in single phase or in 3-phase (Y) configuration. Connection to the mains is achieved via the 6-pole connector (X1). With the wire jumpers B10/20/30 in Y-position (standard configuration) each T unit is connected between its defined input line and the neutral. (Changing of the configuration by the customer is not recommended.) An input filter, provided in the supply line to each T unit minimizes the conducted noise at the input of the system. The positive output of each T unit is separately fed to the common power bus and is decoupled depending upon the backplane type, either by a fuse (F11/21/31) or by a decoupling diode (D11/21/31). The fuses (cartridge type) are externally accessible from the frontside. The BPF versions are fitted with a common preload (R25). Additional output capacitors (up to 3 per

output, 10 mF each) further reduce the low frequency output ripple and provide enhanced hold-up time.

All relevant monitoring signals as well as control signal inputs and outputs are accessible at the signal terminal strip (X5). The jumper strip (X3) allows system specific signals according to different jumper settings. An auxiliary circuit (protected by a fuse F1, rated T1A, 250 V, 5 – 20 mm) allows a relay to be directly driven for system specific control functions.

Each T unit provides an individually adjustable power down signal enabling bus status monitoring at different voltage levels. The threshold values can be set at the soldering tabs  $D_{set}$  (R13/14, R23/24 and R33/34).

Note: If a power system is operated with 3 T units per backplane, connection to the mains in a 3-phase configuration (Y or  $\Delta$ ) will provide equal load distribution on the input lines. Furthermore the low frequency ripple at the output of the T units is compensated to zero as long as all 3 T units are in operation.

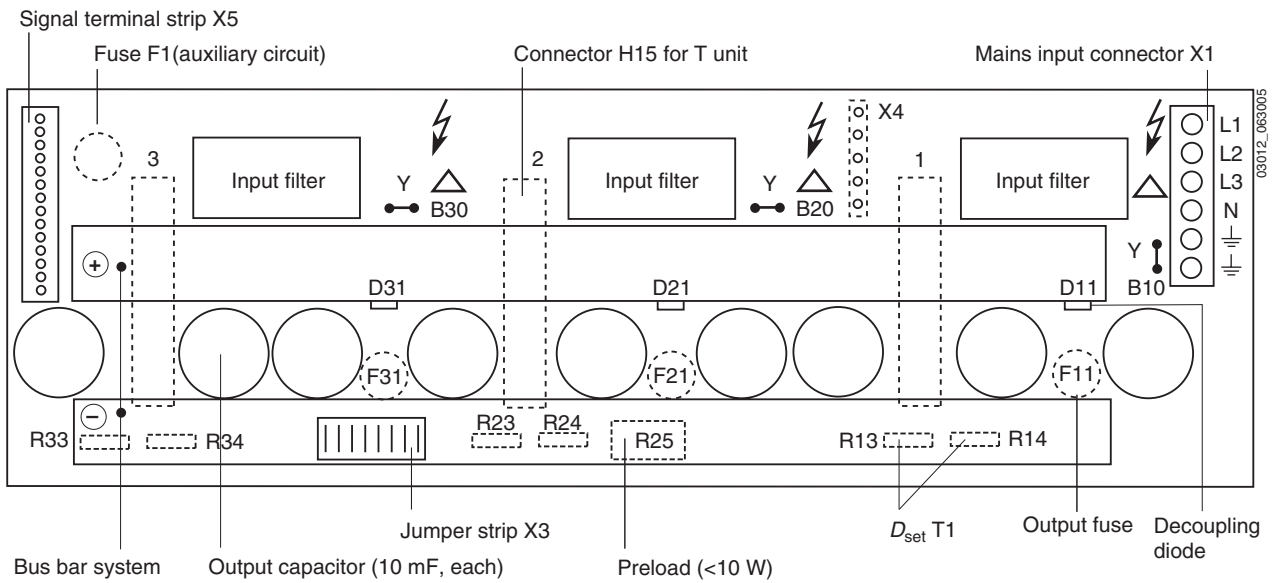

**Fig. 1**  
*Backplane, view from the rear*

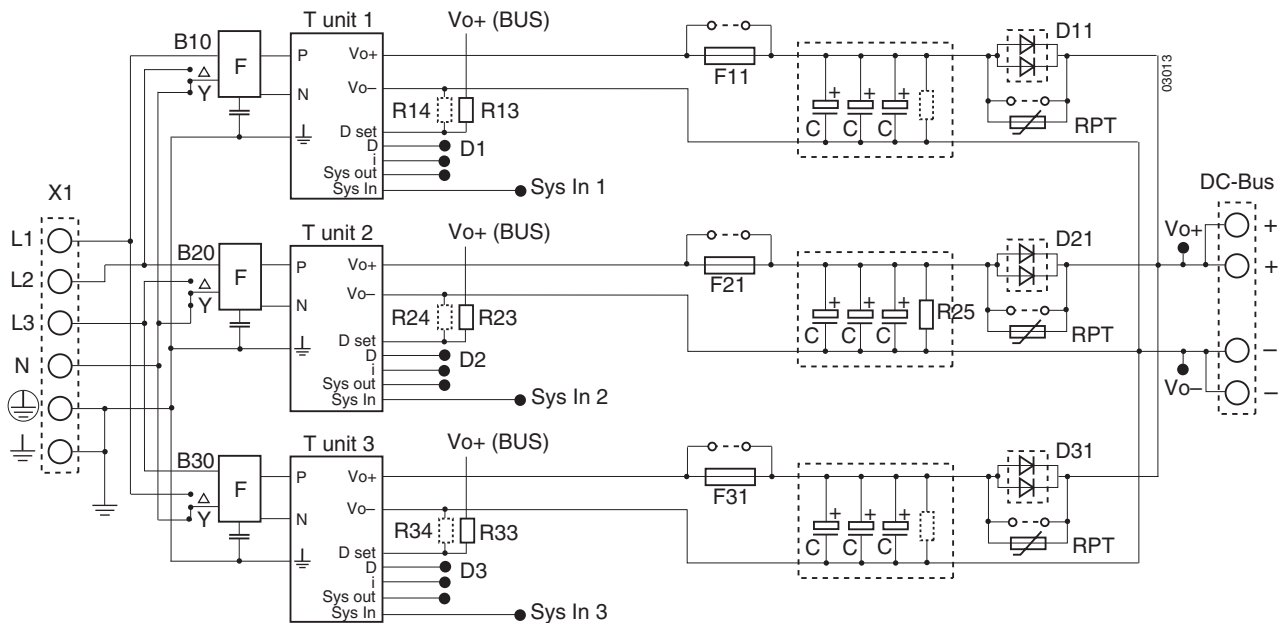

**Fig. 2**  
*Block diagram of backplane*  
F11, 21, 31 fitted to BPF types. D11, 21, 31 fitted to BPD types.

**Mains Input Section**

**Connection to the Mains**

Connection to the mains shall be made via the 6-pole screw terminal connector (X1), located on the right-hand side of the backplane (view from the rear).

For single-phase operation the terminals (L1, L2, and L3) at the female connector X1 should be connected together. The T-series has two AC input voltage ranges. The LT units are optimized for the 230 V mains, the UT units for the 120 V mains. (See also: *T series*)

Table 2: Mains input arrangement

Mains voltage Phase-Earth/Phase-Phase	Single phase L, N, ⊕	3-phase (Y) L1, L2, L3, N, ⊕	Phase - phase (Δ) L1, L2, ⊕	3-phase (Δ) L1, L2, L3, ⊕
230/400 V	LT types	LT types	Not allowed	Not allowed
120/208 V		LT types UT types	LT types only External fuses required	With special backplane BPF 1037 and LT types only

**Single-phase/3-phase (Y) Configuration**

Standard backplane version (Y-configuration)

The layout of the standard backplanes allows operation of the system either in single phase or in 3-phase (Y) configuration. In both configurations each T unit on the backplane is connected between its defined phase and neutral. For single phase operation the AC-input terminals (L1, L2 and L3) should be connected together at the female connector. Connections to neutral and to ground are mandatory. (See also fig.: *Single phase configuration* as well as fig.: *3-phase (Y) configuration*.) Equal load distribution on the input lines at 3-phase configuration will compensate the low frequency ripple at the output to zero.

**Phase to Phase Configuration**

With standard backplane version (Y-configuration)

For LT units exclusively

The layout of the standard backplanes also allows phase-to-phase connection at low mains voltage 208 V e.g. USA, providing full output power from the LT units. In such cases one of the two input lines (L1 or L2) should be connected to the N-terminal at the AC input connector instead of the neutral line. The neutral line is not connected. For safety reasons an external fuse should be fitted in each input line. Connection to the ground is mandatory.

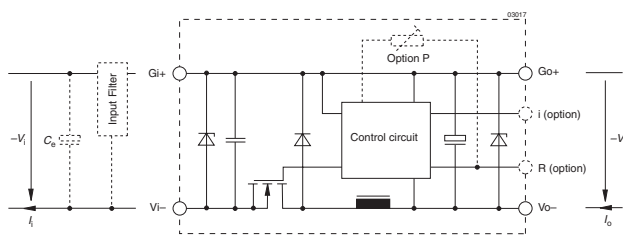

Fig. 3  
Single phase configuration L, N  
230 V mains: LT-types

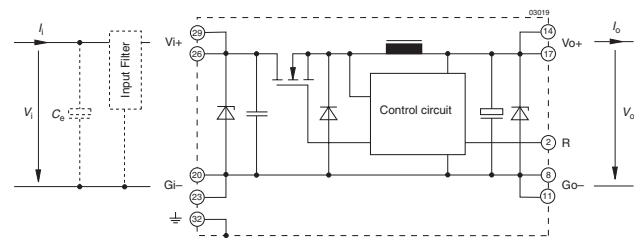

Fig. 5  
Phase to phase configuration L1, L2  
120/208 V mains (e.g. USA): LT types only.  
Not applicable for UT types.

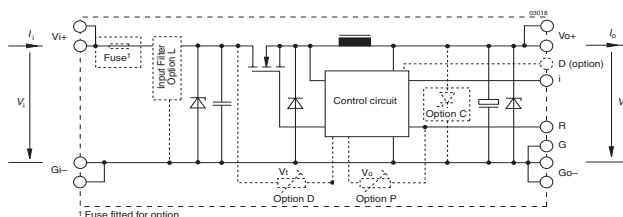

Fig. 4  
3-phase (Y) configuration L1, L2, L3, N  
230/400V mains: LT-types  
120/208V mains: UT-types, LT-types<sup>1</sup>  
<sup>1</sup> Reduced output power with LT types

### 3-phase ( $\Delta$ ) Configuration

With special backplane version BPF 1037

( $\Delta$  configuration) for LT units exclusively

Low mains 120/208 V

The input section of the 3 LT units is wired in a  $\Delta$ -connection enabling full output power of the LT units at low mains input voltage 120/208 V.

Backplanes in 3-phase ( $\Delta$ ) configuration are available on request. Modifications to the backplane in the field from "Y" to " $\Delta$ "-configuration (and vice versa) are not recommended. Maximum nominal input voltage: 230 V<sub>rms</sub> + 10%, phase-to-phase. Higher input voltages may damage the LTs as well as the backplane. Connection to the mains should strictly be done according to fig.: *3-phase ( $\Delta$ ) configuration*. Wrong connection at the input may damage the LT units as well as the backplane. An external fuse needs to be installed into each input line.

### Output Section

#### Power Bus

The backplane is fitted with a generously dimensioned bus bar system. Each bus bar (4 mm thick Alu alloy profile, identified with its polarity) is fitted with 2 captive nuts (M 6) serving as connection points to the load as well as to the battery system. Depending upon the application either the positive or the negative pole of the battery may be earthed.

For application specific requirements such as reduced ripple current, reduced low frequency ripple voltage, enhanced hold-up time or heavy pulse loads, the backplanes are available with additional output capacitors (see table: *Type Survey*). The output capacitors are mounted between the positive and the negative bus rails.

#### Front-end Version

To provide maximum system reliability especially with n+1 redundant systems, each positive output path is fitted with a decoupling diode mounted onto the positive bus rail. The diodes D11, D21 and D31 prevent a possible Power Down on the power bus in the case of a short-circuit across the output of one of the T units. To maintain the signalling functions of the T unit(s) in the case of a single inhibit or a single mains phase failure, a PTC in parallel to the decoupling diode allows a small reverse current from the DC bus supplying the control functions of the affected T unit.

#### Battery Charger Version

Direct battery charging or powering battery buffered systems require an adequate float charge voltage over the specified temperature range. Decoupling diodes should be avoided due to their voltage drop, affecting the float charge voltage of the battery. To maintain system redundancy adequately rated fuses (F11, F21 and F31, rated F20A minimum, 250 V, 6.3 – 32 mm each) are mounted in each positive output line. In the case of a short circuit across the output of one of the T units the relevant fuse will blow, interrupting the reverse short circuit current supplied by the battery and the remaining T units.

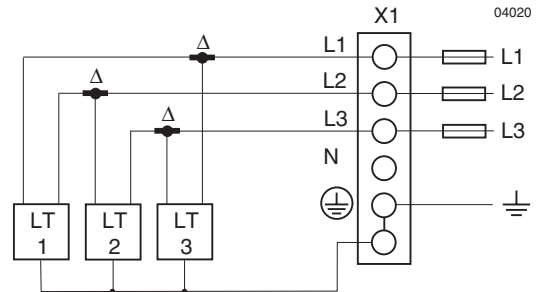

Fig. 6  
3-phase ( $\Delta$ ) configuration, L1, L2, L3  
120/208 V mains (e.g. USA) LT types only.  
Not applicable for UT types.

#### Power Down Signal (D1, D2, D3)

The power down signal monitors the voltage level of the bus bar system. Depending upon the application it may be advantageous to use the power down signal D1 and D2 in a redundant configuration and the third signal (D3) as a separate warning signal at a higher threshold level. For such a configuration the jumpers of X3 should be set in the positions  $\mathfrak{R}D - D1$  and  $\mathfrak{R}D - D2$ . (See fig.: *Jumper strip (X3), Signal meshing*.)

For individual adjustment of the power down level see also: *System Integration*.

#### Inhibit

The output of a T unit may be enabled or disabled by the inhibit input signal. Moreover the output voltage can be controlled with an external temperature sensor connected to this input. If just the inhibit function is used, the units can be individually inhibited. If the output voltage is temperature controlled the same sensor signal should control all units in the rack and the jumpers of X3 should be set in all 3 inhibit positions,  $\mathfrak{R}i - i1$ ,  $\mathfrak{R}i - i2$  and  $\mathfrak{R}i - i3$  (See fig.: *Jumper strip (X3), Signal meshing*.)

#### System Good Signal (Sys In 1, 2, 3/Sys Out 1, 2, 3)

The System Good signal can be used either for status monitoring of each individual T unit or as a combined signal for status monitoring of the whole system. For overall system status monitoring jumpers should be set in the positions Si1-So2, Si2-So3 (See fig. *Jumper strip (X3), Signal meshing*.)

The System Good input of the first T unit in a system (T3) should be referenced to the negative output. This can be done either on the jumper strip X3 with a jumper in position  $\perp - Si3$  (See fig.: *Jumper strip (X3), Signal meshing*.) or directly at the terminal strip X5, by connecting Sys In 3 to Vo-. (See also: *System Integration*.)

**Interface for Remote Signalling and Control**

A signal terminal strip (X5) allows interfacing with the customer's control system.

Each of the signals can be made available as an individual signal or as a combined signal.

Table 3: Terminal strip X5

Connector X5	Signal allocation	Description
1	Vo-	Supply Vo-
2	Sys In 3	Sys Good input T3
3	Sys In 2	Sys Good input T2
4	Sys In 1	Sys Good input T1
5	Sys Out 3	Sys Good output T3
6	Sys Out 2	Sys Good output T2
7	Sys Out 1	Sys Good output T1
8	i3/Ucr	Inhibit T3/Ucr
9	i2/Ucr	Inhibit T2/Ucr
10	i1/Ucr	Inhibit T1/Ucr
11	D3	Power Down T3
12	D2	Power Down T2
13	D1	Power Down T1
14	Vo+	Supply Vo+

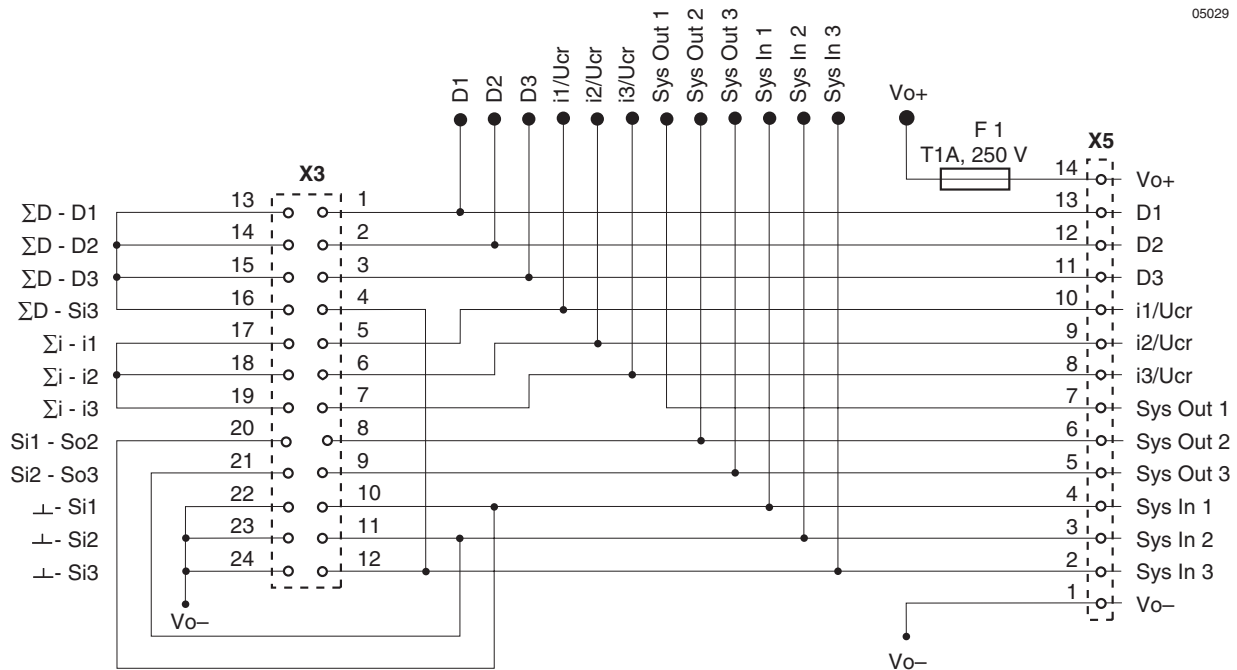

Fig. 7  
Jumper strip (X3), signal meshing

## Electromagnetic Compatibility (EMC)

### Conducted Emission

The battery charger units can be operated in 3 different modes, depending on the load:

- Output voltage regulation
- Output power limitation
- Output current limitation

See also data sheet: *T series*.

In output voltage regulation mode, the conducted noise at the input of the T units is below level B according to CISPR 11/22/EN 55011/55022.

In output power and output current limitation mode, e.g. in the case of charging heavily discharged batteries, the conducted noise may be above level B, but below level A

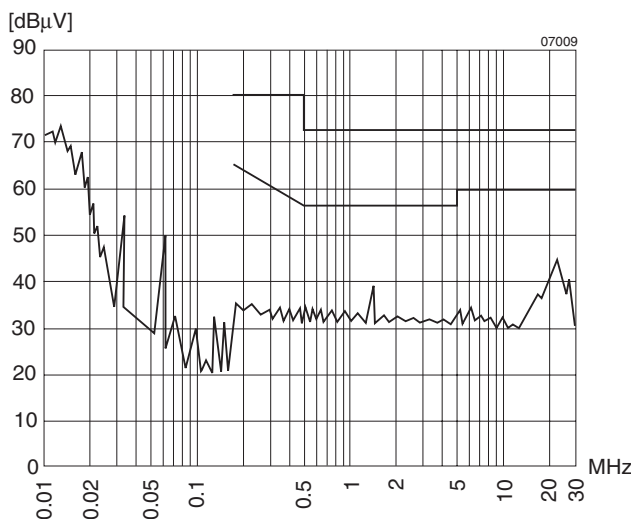
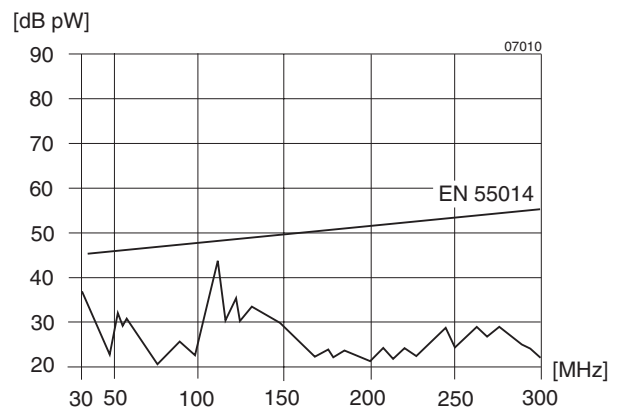

**Fig. 8**  
Typical disturbance voltage (quasi-peak) at the input of a backplane fitted with 3 LT units, input filters and 5 additional output capacitors (10 mF each) according to CISPR11/22 and EN 55011/22, measured at  $U_{i\text{ nom}}$  and  $I_{o\text{ nom}}$ .

### Radiated Emission

To keep the radiated noise of the T units as low as possible they should be mounted into a conductive chromatinized 19" rack, fitted with front panels and the backplane earth connected to the rack.

For integration into non-conductive 19" racks, special front panels with conductive nuts are available on request.



**Fig. 9**  
Typical radiated electromagnetic power (quasi peak) at system input and output of a backplane fitted with 3 LT units, input filters and 5 additional output capacitors (10 mF each) according to CISPR 14 and EN 55014, measured at  $U_{i\text{ nom}}$  and  $I_{o\text{ nom}}$ .

## System Integration

### Mains Input Voltage Monitoring

The T unit interprets a mains failure as a system error, indicated by the red Error LED together with a System Good failure signal. Should a dedicated mains failure identification be required this signal would have to be established externally.

Available signals/signal combinations (Please also refer to the: *T series* data sheet):

The T unit provides two open collector signals, System Good and Power Down.

The System Good signal monitors the operational function of a single T unit. In case of reduced available output power due to a mains failure, a T unit failure or inhibit, the signal changes from low to high impedance.

In systems with battery back-up or with n+1 redundancy the failure of one single unit does not cause a failure of the system as the required output power is still available either from the battery or from the remaining T units. To indicate the status of the whole system, the System Good signals of all 3 units should be connected in series on the backplane.

The System Good output can be combined with similar outputs of other DC-DC converters such as CQ units, integrating the additional information into the overall system status signal.

If only the system status of the T unit is to be monitored, Sys In should be wired to Vo-.

The Power Down signal monitors the output voltage level of the bus bar system. The threshold levels of the 3 possible signals can be individually adjusted by means of resistors

R 13/14...R 33/34 (see: *T series* data sheet) and be used for:

- Save data
- Disconnecting the load or part of it
- Performing a battery test

In systems with battery back-up it may be desirable to extend system operation in case of long term mains failures by disconnecting an uncritical part of the load at a certain bus voltage level, triggered by one of the 3 possible power down signals. The 2 remaining signals can be set to the low battery discharge level to get a redundant signal (wired AND) for finally disconnecting the critical part of the load.

**Note:** The Power Down signal has an enlarged hysteresis of approximately 6 V for T 1740 units and 3.5 V for T 1240 units.

The Power Down signal(s) can be combined with the System Good signal to give a wired AND (see: *T series* data sheet). In such cases the resulting alarm only becomes active as a result of a mains failure or a converter failure together with a heavily discharged battery.

### Battery Selection

When selecting a battery, the following aspects should be considered:

1. Batteries are normally specified at 20°C.  
Steady operation at higher temperatures will shorten the life time of a battery. For every 10 K temperature increase the battery lifetime is halved.
2. Worst case considerations with regard to the necessary battery capacity should include operation at the lowest possible temperature and highest possible discharge current, since under such conditions a substantial capacity drop has to be expected.
3. The capacity of a battery deteriorates with time. Therefore decisions on battery capacity should be based upon 20% ageing loss.
4. Consult the battery manufacturer for correct layout of the battery system.

### Selecting the Right Battery and Backplane Configuration

As mentioned in the T series data sheet the power factor correction at the input of the T unit generates a ripple voltage at the output of twice the input frequency, causing a ripple current into the connected battery.

For most battery types the low frequency ripple current should not exceed 5 A<sub>rms</sub> per 100 Ah (0.05 C). Some manufacturers (with newer battery technology) specify 10 A<sub>rms</sub> per 100 Ah (0.1 C).

Excessive ripple current can increase the battery temperature and reduces the battery lifetime. For a single-phase system additional output capacitors may be necessary depending upon the selected battery type.

**Note:** With the T units symmetrically connected to a 3-phase (Y) mains supply the low frequency output ripple is virtually zero, only a high frequency ripple and noise of <100 mV<sub>pp</sub> at the switching frequency of 65.5 kHz remains.

**Dimensioning Example of a Battery Charger System in Single-Phase Connection**

Battery charger system in single-phase connection:  
230 V, 50 Hz, load: 1 kW, battery back-up: 3 h

Battery charger:  
3 LT 1740 , n+1 redundant configuration, 1.6 kW

Conditions:  
 $T_A = -10$  to  $40^\circ\text{C}$  for both, charger and battery

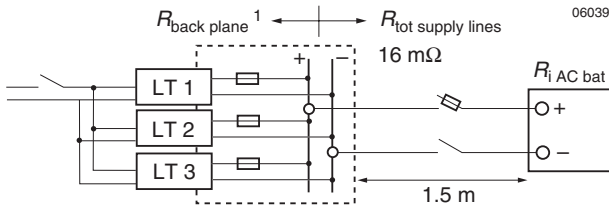

<sup>1</sup> The resistance on the backplane ( $R_{\text{back plane}}$ ) is already taken into account in the following two graphs.

**Fig. 10**  
System set-up

Battery specification (at  $20^\circ\text{C}$ ):

- 24 cells, 2.23 V/cell, float charge voltage 53.5 V
- Permissible ripple current  $I_{\text{rms bat}}$ : 0.05 C (5% of battery capacity)
- Temperature coefficient  $-3$  mV/K per cell
- Max. discharge current 20 A
- Capacity at  $-10^\circ\text{C}$  and 0.2 C discharge: 70%

Calculation of battery size:

Load 20 A, back-up 3 h, ageing loss 20% therefore ageing factor 0.8, derating factor for temperature and discharge current 0.7

$$Q_{\text{bat}} [\text{Ah}] = I_{\text{load}} \cdot t_{\text{back-up}} / (f_{\text{ageing}} \cdot f_{T_A/\text{discharge}}) = 20 [\text{A}] \cdot 3 [\text{h}] / (0.8 \cdot 0.7) = 107 [\text{Ah}]$$

next closest battery configuration: 120 Ah or 95 Ah

Decision: Battery with 95 Ah ( $R_{i \text{ DC}}: 28 \text{ m}\Omega$ )

Calculation of the ripple current:

The ripple current to the battery can either be measured or calculated. The diagrams allow a good estimation of the relationship between the ripple current to the battery  $I_{\text{rms bat}}$  and the load current  $I_{\text{Load}}$  of a given system resistance  $R_{\text{Sys}}$ . The system resistance is the sum of the resistance of the supply and the AC resistance of the battery.

The AC resistance is defined as the relationship between the AC voltage and the AC current to the battery measured with a capacitively coupled 100 Hz AC source. In the example the system resistance is:

$$R_{\text{Sys}} = R_{\text{supply rms}} + R_{i \text{ AC bat}} = 16 \text{ m}\Omega + 16 \text{ m}\Omega = 32 \text{ m}\Omega$$

Permissible ripple current:

$$I_{\text{rms bat}} = 0.05 \cdot 95 \text{ Ah} = 4.75 \text{ A}_{\text{rms}}$$

Calculated ripple current:

With 3 LT 1740 without capacitance on the backplane

$$I_{\text{rms bat}} = I_{\text{load}} \cdot \text{factor } y = 19 \text{ A} \cdot 0.198 = 3.76 \text{ A}_{\text{rms}} = 0.04 \text{ C}$$

With 3 LT 1740 and 50 mF on the backplane

$$I_{\text{rms bat}} = 19 \text{ A} \cdot 0.16 = 3.04 \text{ A}_{\text{rms}} = 0.032 \text{ C}$$

With 3 LT 1740 and 90 mF on the backplane

$$I_{\text{rms bat}} = 19 \text{ A} \cdot 0.13 = 2.47 \text{ A}_{\text{rms}} = 0.026 \text{ C}$$

All three examples give a value below the permissible ripple current.

Additional capacitance on the backplane not only reduces the AC ripple on the battery, but stabilizes the output voltage during fast load changes.

Where the ripple current should be reduced even more, the system resistance  $R_{\text{Sys}}$  could be increased with a special choke set into the battery supply line. For further information please contact Power-One.

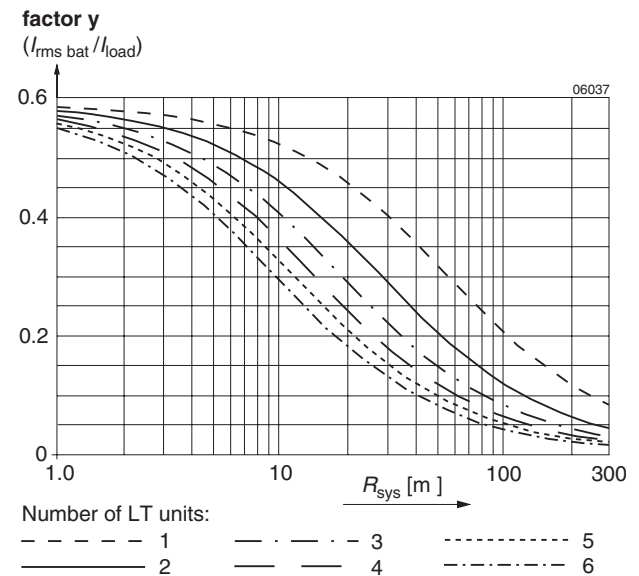

**Fig. 11**  
 $I_{\text{rms bat}}/I_{\text{load}}$  versus system resistance ( $R_{\text{Sys}}$ ). Up to 6 T units in parallel, without additional output capacitors

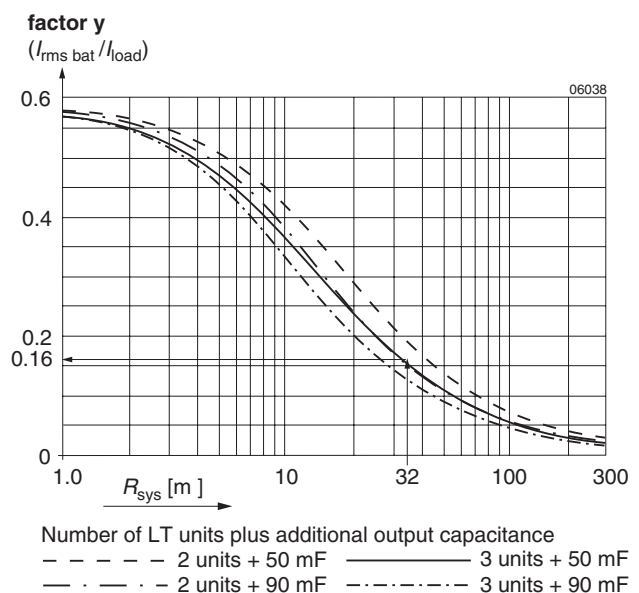

**Fig. 12**  
 $I_{\text{rms bat}}/I_{\text{load}}$  versus system resistance ( $R_{\text{Sys}}$ ). 2 and 3 T units in parallel, with additional output capacitors

**Mechanical Data**

Dimensions in mm. Tolerances  $\pm 0.3$  mm unless otherwise indicated.

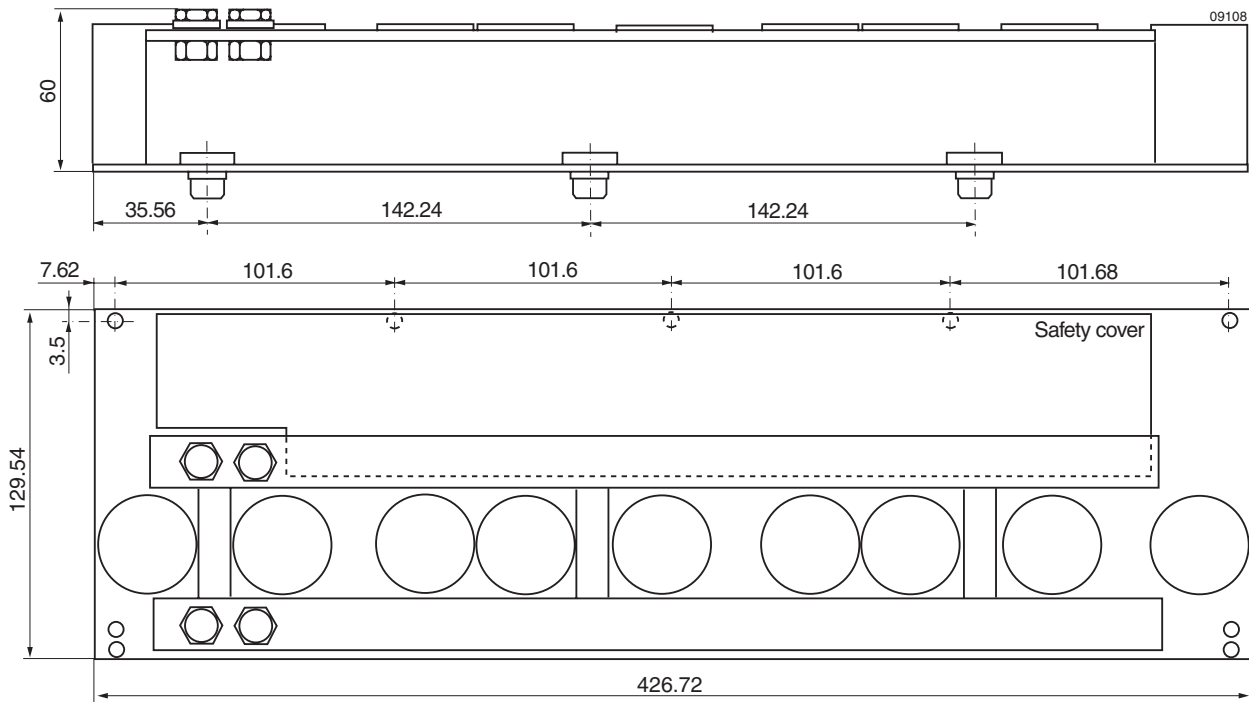

Fig. 13  
Backplane for 19" rack, weight: 1.7 kg

## Safety and Installation Instructions

### Transportation

For transportation use standard Power-One packaging material.

Racks fitted with backplanes are not designed for transportation with the T series AC-DC converters fitted into the racks.

### Connector Pin Allocation

The power output is provided via the two bus bars, the positive one designated Vo+, the negative one Vo-. The following pin allocation tables define the electrical potentials and the physical pin positions on the connectors of the backplanes.

Table 4: Pin allocation of the mains input connector X1

Pin no.	Electrical determination	Pin designation
1	Input phase 1	L1
2	Input phase 2	L2
3	Input phase 3	L3
4	Input neutral	N
5	Protective earth	⊕
6	Protective earth	⊕

Input connector X1 is provided with a matching male connector at delivery. Standard configuration: Pins 1, 2 and 3 are interconnected (for single phase operation).

Table 5: Pin allocation of the signal terminal strip X5

Pin no.	Electrical determination	Pin designation
1	Supply negative (return potential)	Vo-
2	Sys good input of T unit no. 3	Sys In 3
3	Sys good input of T unit no. 2	Sys In 2
4	Sys good input of T unit no. 1	Sys In 1
5	Sys good output of T unit no. 3	Sys Out 3
6	Sys good output of T unit no. 2	Sys Out 2
7	Sys good output of T unit no. 1	Sys Out 1
8	Inhibit or Ucr of T unit no. 3	i3/Ucr
9	Inhibit or Ucr of T unit no. 2	i2/Ucr
10	Inhibit or Ucr of T unit no. 1	i3/Ucr
11	Power down of T unit no. 3	D3
12	Power down of T unit no. 2	D2
13	Power down of T unit no. 1	D1
14	Supply positive	Vo+

The signal terminal strip X5 is provided with a matching female connector at delivery.

The jumper strip X3 is provided with 12 jumpers at delivery.

The pin allocation of the jumper strip is described in fig. Jumper strip (X3), signal meshing.

### Installation Instruction

The BPD/BPF series backplanes are components, intended exclusively for inclusion within other equipment by an industrial assembly operation or by professional installers. Installation must strictly follow the national safety regulations in compliance with the enclosure, mounting, creepage, clearance, casualty, markings and segregation requirements of the end-use application. See also: *Technical Information: Installation and Application.*

**Caution:** It is the responsibility of the design engineer and of the installer to define and apply a safety concept for the whole system which is provided with a Power-One backplane. The following are under the aspects which have to be considered:

- Consult the T-series AC-DC converters data sheet prior to connecting the system to the mains.
- The necessity to provide a cover over the live parts at the mains input (hazardous voltage) or over the DC-bus bars (energy hazard), preventing accidental contact during installation, start-up of a system or maintenance, depends on the final installation as well as on the applicable safety requirements.
- Service should be carried out by qualified personnel only.
- Fuses should be replaced with the same types only.
- The earth terminal on the backplane must be connected to safety ground.
- Backplanes in 3-phase (Δ) configuration are available on request. Modifications to the backplane in the field from "Y"- to "Δ"-configuration (and vice versa) are not recommended.
- The maximum nominal input voltage is 230 V<sub>rms</sub> +10%. Higher input voltages may damage the T series AC-DC converters as well as the backplane.
- Empty spaces in a rack should be covered by a dummy front panel.

**Caution:** Prior to handling, the backplane must be disconnected from mains and from other sources (e.g. batteries). Check for hazardous voltages and hazardous energy before and after altering any connections. Hazardous energy levels may be present at the output terminals even after the mains input voltage has been disconnected from the unit. This is indicated by the red error LEDs of the T series AC-DC converters. It is the responsibility of the installer to prevent an unwanted short-circuit across the output of the backplane, of the battery and of each T series AC-DC converter. In case of a short circuit across the output of a T unit, all LEDs will be off, although the mains may be present.

The backplanes are intended for stationary applications. They shall be installed in 19" racks according to DIN 41494.

Install the backplanes vertically, the mains input connector X1 being on the right hand side of the backplane (view from the back) and make sure that there is sufficient airflow available for convection cooling of the T-series AC-DC converters.

Mechanical fixing shall be made via 10 screws M2.5 – 10 and 10 nuts M2.5. When mounting a backplane to a rack, fit two T units into the H 15 female connectors on the backplane prior to fixing the backplane to the rack. This ensures correct positioning of the female connectors on the backplane with respect to the given position of the male connectors of the T units in the rack. With the backplane improperly positioned, the connectors of the T units and the female connectors on the backplane may be damaged. In order to maintain correct positioning, use all the available mounting holes.

Connection to the supply system shall be made via the 6-pole screw terminal connector X1 according to: *Connector Pin Allocation* and *Mechanical Data*.

The connector X1 of the backplanes (class I equipment) is provided with two protective earth terminals (⊕), which are reliably connected with the protective earth pins of the connectors for the T units. For safety reasons it is essential to connect at minimum one of these terminals with the protective earth of the supply system. Since the earth leakage current exceeds 3.5 mA, the system must be permanently connected or it must be pluggable equipment type B according to IEC/EN 60950. The earth connection must be performed before connecting the supply.

To maintain good electrical connection, the AC input, earth and signal to the terminal strip wiring should be secured, using tie wraps, to prevent stress upon the wires and the connectors.

Refer to *Mains Input Section* to ensure that phase and neutral configuration matches with the backplane and T series AC-DC converter types. Wrong connection at the input may damage the T series AC-DC converters as well as the backplane. Standard backplanes are designed for a 3-phase system in Y connection with a phase to neutral voltage of 230 V or 120 V where connection to neutral is mandatory. Integration into a 3-phase system in Δ configuration (120/208 V and without connection to neutral) is only possible with LT AC-DC converters together with the special backplane BPF 1037.

For safety reasons, a mains switch for line interruption is required.

The backplane does not provide any input fuses. The input fuses of the T series AC-DC converters in the connection from the L terminal are designed to protect the units in case of overcurrent and may not be able to satisfy all customer requirements. An external input fuse suitable for the application and in compliance with the local requirements in the wiring to each phase and to the neutral terminal may therefore be necessary to ensure compliance with local requirements. A second fuse in the wiring to each input terminal is needed if:

- Standard backplanes are used in phase to phase configuration
- Local requirements demand an individual fuse in each source line
- Neutral to earth impedance is high or undefined

- Phase and neutral of the mains are not defined or cannot be assigned to the corresponding terminals (L to phase and N to neutral).

**Important:** Do not open the modules, or guarantee will be invalidated.

#### **Additional Information for Installation of Battery Charger Systems:**

Reverse polarity connection of the battery may damage the battery, the backplane(s) and the battery chargers.

Prior to putting a system into operation, check whether the position of the cell voltage selector switch of each T series AC-DC converter corresponds to the required battery cell voltage.

For battery maintenance please contact the battery manufacturer.

Exchanging a battery should always include the whole battery bank. New batteries should be of the same type, with the same cell voltage and temperature coefficient.

For expansion of battery systems contact the battery manufacturer.

For battery location and connection please refer to VDE 0510, part 2.

In battery charger systems, safety standards demand that a battery can be completely disconnected from the power system including the battery system ground. Depending upon the project specific requirements, disconnecting may either occur by a manually operated switch with fuses, or automatically by means of a circuit breaker.

**Caution:** Care should be taken during system set-up or after maintenance when connecting a battery to the power bus of a backplane (BPF types) fitted with fuses. The T series AC-DC converter system with the backplanes should be switched to the mains prior to connecting the battery to the power bus, since the reverse current from the battery into the uncharged output capacitors of the T units and the backplane may damage the fuses.

Make sure that there is sufficient airflow available for convection cooling. This should be verified by measuring the case temperature of each T series AC-DC converter when the complete backplane is installed and operated in the end-use application. The maximum specified case temperature  $T_{C\ max}$  of the T series AC-DC converters must not be exceeded.

Ensure that a unit failure (e.g. by an internal short-circuit) does not result in a hazardous condition. See also: *Safety of operator accessible output circuit*.

#### **Standards and approvals**

All backplanes correspond to class I equipment.

They have been designed in accordance with UL 1950, CAN/CSA C22.2 No. 950-95 and IEC/EN 60950 standards. Safety approvals are not provided.

The units have been evaluated for:

- Building in
- Basic insulation between input and earth, based on 250 V AC
- Double or reinforced insulation between input and output, based on 250 V AC
- Operational insulation between output and earth
- The use in a pollution degree 2 environment
- Connecting the input to a primary circuit with a maximum transient rating of 2500 V (overvoltage class III based on a 110 V primary circuit, overvoltage class II based on a 230 V primary circuit).

### Troubleshooting

See also: *T series AC-DC converters data sheet Functional Features.*

- All T-series AC-DC converters are operating, all Sys OK LEDs are OFF.
  - Sys In is not referenced to Vo–
- 3-phase AC input, Y-configuration. One T unit indicates Error.
  - single T unit failure or
  - single T unit inhibit or
  - single phase mains failure
- All System OK LEDs are OFF, all T units indicate Error.
  - mains failure or
  - all T units inhibited, e.g. battery test or less likely
  - all T units have a failure
- The red Error LED of one of the T units is ON.
  - T unit with Error LED ON has an overtemperature, the output is automatically re-enabled when the temperature drops below the limit.
- The red Error LED flickers.
  - overvoltage disturbance from the mains.
- One of the T units has all LEDs OFF.
  - short circuit across output of a T unit.
- All Sys OK LEDs ON, at one T unit the Uo OK LED is ON. The remaining T unit are below the threshold level of the power down signal with the LED Uo OK OFF.
  - a fuse on the backplane damaged, relevant T unit with Uo OK ON.
- All LEDs at the T units are OFF, mains is apparent.
  - short circuit across the power bus
- Single phase AC input. Only one T unit is in operation.
  - wire jumpers on mains input connector X1 not connected to L2/ L3 input terminals
- All Sys Good and Uo OK LEDs are ON, no output power.
  - output not connected to the system
- All T units are operating. One or several T units indicate Error with the Uo OK LEDs OFF although the bus voltage is present.
  - Dset not referenced to Vo+

### Protection Degree

The protection degree of the backplanes is IP 00.

### Isolation

The electric strength test is performed as factory test in accordance with IEC/EN 60950 and UL 1950 and should not be repeated in the field. Power-One will not honor any guarantee claims resulting from electric strength field tests.

The electric strength test is performed as factory test in accordance with IEC/EN 60950 and UL 1950. Nor this test nor the insulation resistance measuring should be repeated in the field. Power-One will not honor any guarantee claims resulting from field tests with high voltages.

**Important:** The backplane must carry the safety covers, which prevent from touching conductive parts. Such covers are mounted on both sides of the printed circuit board and over the bus bars. Removing the protection covers will provoke danger of high voltage or high energy impact! Testing by applying AC voltages will result in high and dangerous leakage currents flowing through the Y-capacitors (see fig.: *Block diagram of backplane*).

Table 6: Isolation

Characteristic		Input to earth	Input to output	Output to earth	Unit
Electric strength test voltage	Required according to IEC/EN 60950	1.5	3.0	0.5	kV <sub>rms</sub>
		2.1	4.2	0.7	kV DC
	Actual factory test 1 s	2.8	4.2	1.4	
	AC test voltage equivalent to actual factory test	2.0	3.0	1.0	kV <sub>rms</sub>
Insulation resistance at 500 V DC		>300	>300	>300	MΩ

For creepage distances and clearances refer to: *Technical Information: Safety*.

### Leakage Currents in AC-DC operation

Leakage currents flow due to internal leakage capacitance and RFI suppression Y-capacitors. The current values are proportional to the mains voltage and nearly proportional to the mains frequency. They are specified at the maximum operating input voltage, where phase, neutral and protective earth are correctly connected as required for class I equipment.

Under test conditions, the leakage current flows through a measuring instrument (MI) as described in fig.: *Measuring instrument for earth leakage current tests*, which takes into account impedance and sensitivity of a person touching unearthed accessible parts. The current value is calculated by dividing the measured voltage by 500 Ω. If inputs and/or outputs of backplanes are connected in parallel, their individual leakage currents are added.

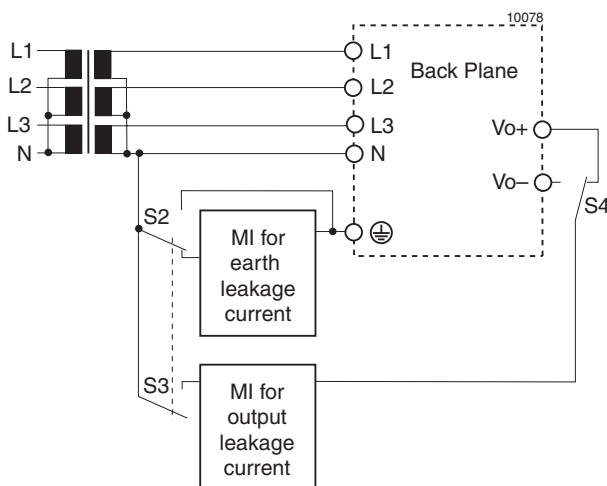

Fig. 15  
Test set-up for leakage current tests on class I equipment in phase-to-phase or 3-phase configuration of backplanes fitted with LT units.

S2/3 select either the earth or output leakage current measurements, S4 selects the leakage current measurements of either the positive or negative output.

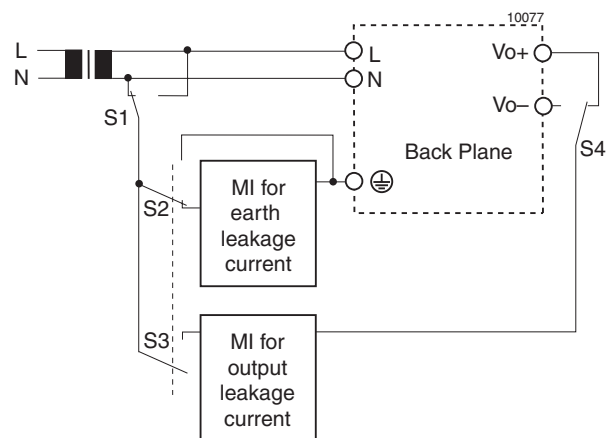

Fig. 14  
Test set-up for leakage current tests on class I equipment in single phase configuration.

S1 is used to simulate the interchanging of phase and neutral, S2/3 select either the earth or output leakage current measurements, S4 selects the leakage current measurement of either the positive or negative output.

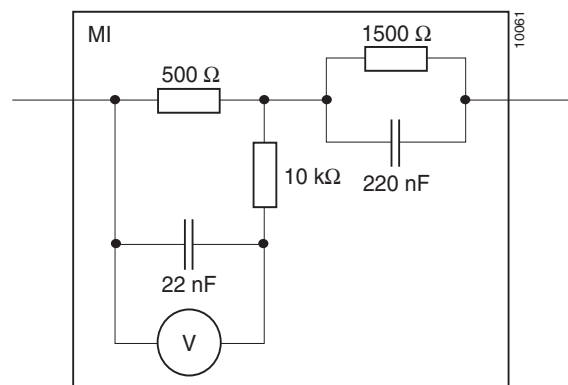

Fig. 16  
Measuring instrument (MI) for earth leakage current tests according to IEC/EN 60950, Annex D.

Table 7: Leakage currents in single phase configuration (= worst case)

Characteristic		Backplane without T unit	Backplane with one T unit	Backplane with two T units	Backplane with three T units	Unit
Earth leakage current	Permissible according to IEC/EN 60950	5% of the input current per phase <sup>1</sup>				–
	Specified value at 255 V, 50 Hz <sup>2</sup>	2.6	4.4	6.2	7.9	mA
	Specified value at 127 V, 60 Hz <sup>2</sup>	1.6	2.6	3.7	4.7	
Output leakage current	Permissible according to IEC/EN 60950	0.25	0.25	0.25	0.25	
Output leakage current	Specified value at 255 V, 50 Hz	–	<0.1	<0.1	<0.1	
	Specified value at 127 V, 60 Hz	–	<0.1	<0.1	<0.1	

<sup>1</sup> If the value exceeds 3.5 mA, equipment must be pluggable equipment type B or permanently connected, according to IEC/EN 60950.

<sup>2</sup> In best case configuration (3-phase), earth leakage currents compensate to 0 mA.

### Safety of operator accessible output circuit

If the output circuit of an AC-DC converter is operator accessible, it shall be an SELV circuit according to IEC/EN 60950 related safety standards.

The following table shows a possible installation configuration, compliance with which causes the output circuit of the AC-DC converter to be an SELV circuit according to IEC/EN 60950 up to a configured output

voltage of 56.5 V.

However, it is the sole responsibility of the installer to assure the compliance with the relevant and applicable safety regulations. More information is given in: *Technical Information: Safety*.

Table 8: Safety concept leading to an SELV circuit



Conditions	AC-DC converter	Installation	Result
<b>Supply voltage</b>	<b>Grade of isolation between input and output, provided by the AC-DC converter</b>	<b>Measures to achieve the resulting safety status of the output circuit</b>	<b>Safety status of the AC-DC converter output circuit</b>
Mains ≤250 V AC	Double or reinforced	Installation according to the applicable standards	SELV circuit

NUCLEAR AND MEDICAL APPLICATIONS - Power-One products are not designed, intended for use in, or authorized for use as critical components in life support systems, equipment used in hazardous environments, or nuclear control systems without the express written consent of the respective divisional president of Power-One, Inc.

TECHNICAL REVISIONS - The appearance of products, including safety agency certifications pictured on labels, may change depending on the date manufactured. Specifications are subject to change without notice.

## Looking for pricing, stock, or lifecycle information?

Click below to explore more details on WIN SOURCE:

-  [View BPD1003 on WIN SOURCE](#)
-  [Bel Power Solutions Information](#)

## Optimize Your Supply Chain with WIN SOURCE Solutions

-  Global Sourcing Solution
-  Obsolete Management
-  Cost Control Management
-  Shortage Management
-  Alternative Solution
-  Excess Inventory Management