



THE DATASHEET OF PAM8901JER



Description

The PAM8901 / PAM8908 stereo headphone driver is designed for portable equipment where board space is at a premium. The PAM8901 / PAM8908 uses a unique, patent pending architecture to produce a ground-referenced output from a single supply, eliminating the need for large DC-blocking capacitors, saving cost, board space, and component height.

The PAM8901 / PAM8908 delivers up to 25mW per channel into a 16Ω load and has low 0.03% THD+N. A high power-supply rejection ratio (80dB at 1kHz) allows this device to operate from noisy digital supplies without an additional linear regulator.

The PAM8901 / PAM8908 operates from a single supply from 2.5V to 5.5V, has short-circuit and over temperature protection. Shutdown mode reduces supply current to less than 1μA.

Features

- Patent Pending 3 Phase Power Line Shift Charge Pump Eliminates Need for DC-Blocking Capacitors
- TrueCapFree Architecture, Output Biased at 0V (System Ground)
- Excellent Low Frequency Fidelity
- 80dB PSRR at 1kHz
- Less than 1μA Shutdown Current
- Support Both Fully Differential and Single-Ended Inputs
- Short Circuit and Over Temperature Protection
- Selectable Gain Settings: -6dB, 0dB, 3dB and 6dB
- Available in Space Saving Packages: U-QFN3030-16 (Type US)
- Lead Free and Green Devices Available (RoHS Compliant)
- **Totally Lead-Free & Fully RoHS Compliant (Notes 1 & 2)**
- **Halogen and Antimony Free. "Green Device (Note 3)**

Pin Assignments

(Top View)

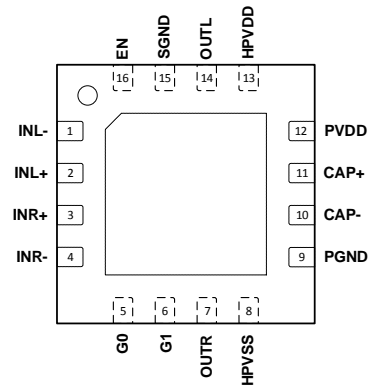

U-QFN3030-16 (Type US)

(Top View)

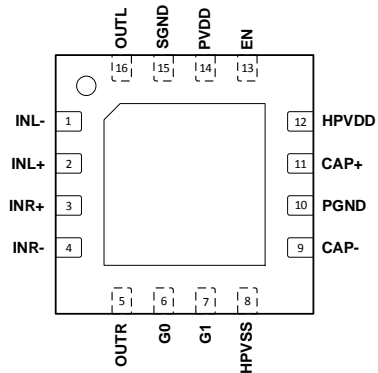

U-QFN3030-16 (Type US)

Applications

- Smart Phones/Cellular Phones
- Notebook Computers
- Portable DVD Player
- Personal Digital Assistants (PDAs)
- Electronic Dictionaries
- Digital Still Cameras
- Portable Gaming

Notes: 1. No purposely added lead. Fully EU Directive 2002/95/EC (RoHS) & 2011/65/EU (RoHS 2) compliant.
 2. See http://www.diodes.com/quality/lead_free.html for more information about Diodes Incorporated's definitions of Halogen- and Antimony-free, "Green" and Lead-free.
 3. Halogen- and Antimony-free "Green" products are defined as those which contain <900ppm bromine, <900ppm chlorine (<1500ppm total Br + Cl) and <1000ppm antimony compounds.

Typical Applications Circuit

Typical Application Configuration with Differential Input Signals

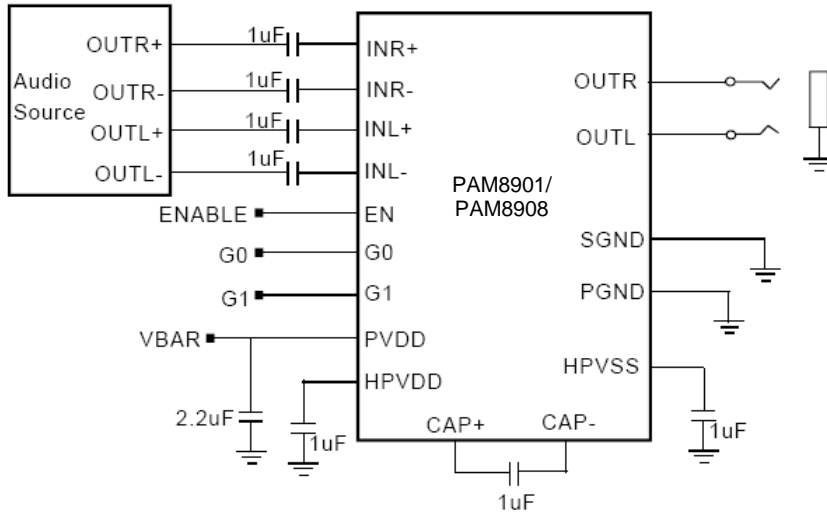

Typical Application Configuration with Single-Ended Input Signal

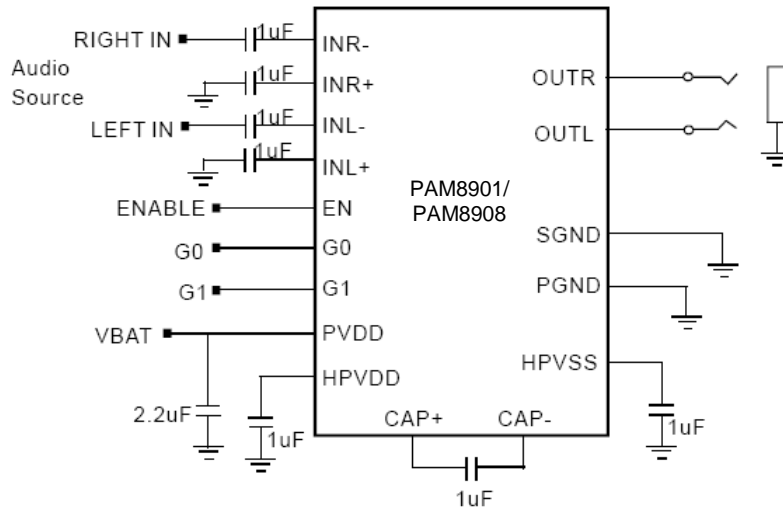

NEW PRODUCT

Pin Descriptions

Pin Number		Pin Name	I/O/P	Function
PAM8901	PAM8908			
1	1	INL-	I	Inverting left input for differential signals.
2	2	INL+	I	Non-inverting left input for differential signals.
3	3	INR+	I	Inverting right input for differential signals.
4	4	INR-	I	Non-inverting right input for differential signals.
5	6	G0	I	Gain select bit 0
6	7	G1	I	Gain select bit 1
7	5	OUTR	O	Right headphone amplifier output. Connect to right terminal of headphone jack.
8	8	HPVSS	P	Charge pump output and negative power supply for output amplifiers; connect 1 μ F capacitor to GND
9	10	PGND	P	Power Ground
10	9	CAP-	O	Charge pump negative flying cap.
11	11	CAP+	O	Charge pump positive flying cap.
12	14	PVDD	P	Power V _{DD} .
13	12	HPVDD	O	Positive power supply for headphone amplifiers. Charge pump positive half V _{DD} output.
14	16	OUTL	O	Left headphone amplifier output. Connect to left terminal of headphone jack.
15	15	SGND	I	Amplifier reference voltage.
16	13	EN	I	Amplifier enabled. Connect to logic low to shutdown; connect to logic high to activate

Functional Block Diagram

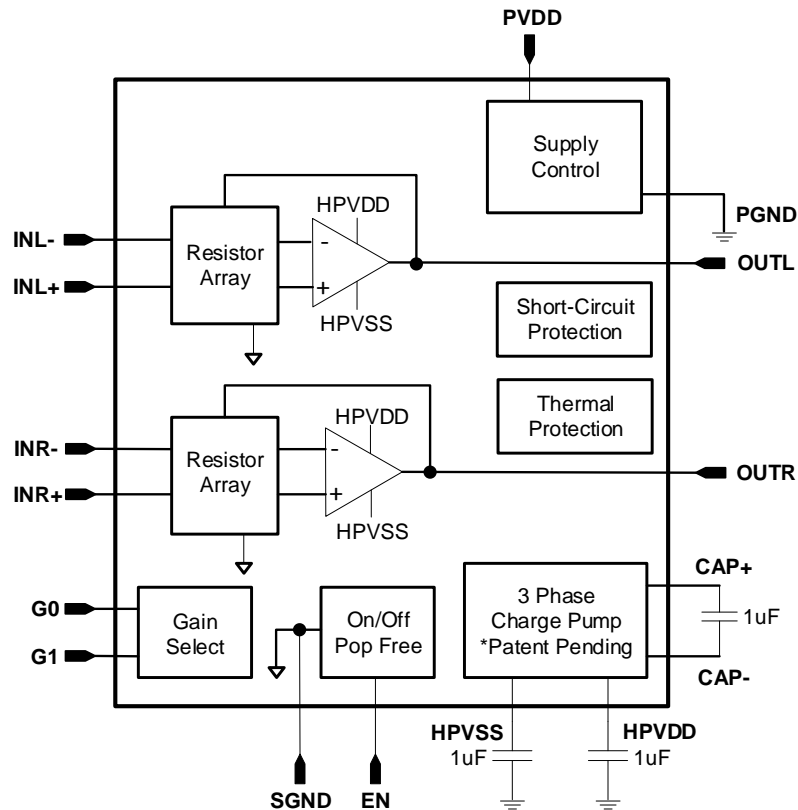

Absolute Maximum Ratings (@T_A = +25°C, unless otherwise specified.) (Note 4)

These are stress ratings only and functional operation is not implied. Exposure to absolute maximum ratings for prolonged time periods may affect device reliability. All voltages are with respect to ground.

Parameter	Rating	Unit
Supply Voltage (PV _{DD})	6.0	V
Input Voltage (INR+, INR-, INL+, INL-)	HPV _{SS} -0.3 to HPV _{DD} +0.3	V
Control Interface Voltage (G0, G1, EN)	-0.3 to PV _{DD} +0.3	V
Storage Temperature	-65 to +150	°C
Maximum Junction Temperature	+150	
Soldering Temperature	+250, 10sec	

Note: 4. Stresses greater than the 'Absolute Maximum Ratings' specified above may cause permanent damage to the device. These are stress ratings only; functional operation of the device at these or any other conditions exceeding those indicated in this specification is not implied. Device reliability may be affected by exposure to absolute maximum rating conditions for extended periods of time.

Recommended Operating Conditions (@T_A = +25°C, unless otherwise specified.)

Symbol	Parameter	Rating	Unit
V _{DD}	Supply Voltage Range	2.5 to 5.5	V
T _A	Ambient Temperature Range	-40 to +85	°C
T _J	Junction Temperature Range	-40 to +125	

Thermal Information (@T_A = +25°C, unless otherwise specified.)

Symbol	Parameter	Package	Max	Unit
θ _{JA}	Thermal Resistance (Junction to Ambient)	U-QFN3030-16 (Type US)	35	°C/W
θ _{JC}	Thermal Resistance (Junction to Case)	U-QFN3030-16 (Type US)	14	°C/W

Electrical Characteristics (@ $T_A = +25^\circ\text{C}$, $PV_{DD} = 3.6\text{V}$, $R_L = 16\Omega$, unless otherwise specified.)

Symbol	Parameter	Test Conditions	Min	Typ	Max	Units
PV_{DD}	Supply Voltage	—	2.5	—	5.5	V
I_Q	Quiescent Current	EN = PV_{DD} , No Load	—	4	—	mA
P_O	Output Power per Channel	THD = 1%, f = 1kHz, $R_L = 16\Omega$	—	35	—	mW
		THD = 1%, f = 1kHz, $R_L = 32\Omega$	—	25	—	mW
I_{SD}	Shutdown Current	EN = 0V, $PV_{DD} = 2.5\text{V to } 5.5\text{V}$	—	0.1	1	μA
V_{IH}	EN High Level Input Voltage	—	1.4	—	—	V
V_{IL}	EN Low Level Voltage	—	—	—	0.6	V
V_{GH}	G0, G1 High Level Input Voltage	—	1.4	—	—	V
V_{GL}	G0, G1 Low Level Voltage	—	—	—	0.6	V
V_{OS}	Output Offset Voltage	—	—	1	5	mV
AV	Closed-Loop Voltage Gain	G0 = 0V, G1 = 0V	—	-6	—	dB
		G0 = PV_{DD} , G1 = 0V	—	0	—	dB
		G0 = 0V, G1 = PV_{DD}	—	3	—	dB
		G0 = PV_{DD} , G1 = PV_{DD}	—	6	—	dB
PSRR	Power Supply Rejection Ratio	Input A C-GND, f = 1kHz, $V_{PP} = 200\text{mV}$	—	75	—	dB
THD+N	Total Harmonic Distortion Plus Noise	$P_O = 20\text{mW}$, f = 1kHz	—	0.03	—	%
SNR	Signal to Noise Ratio	$P_O = 20\text{mW}$, into 16Ω	—	100	—	dB
EN	Noise Output Voltage	A-Weighted	—	10	—	μV_{RMS}
CS	Crosstalk	$P_O = 15\text{mW}$, f = 1kHz	—	80	—	dB
f_{osc}	Charge Pump Switching Frequency	—	1.2	1.5	1.8	MHz
t_{ON}	Start-Up Time	EN from low to high	—	0.4	—	Ms
OTP	Thermal Shutdown	Threshold	—	+150	—	$^\circ\text{C}$
OTPH	Thermal Shutdown Hysteresis	Hysteresis	—	+20	—	$^\circ\text{C}$

Typical Performance Characteristics (@ $T_A = +25^\circ\text{C}$, $P_{VDD} = 3.6\text{V}$, $f = 1\text{kHz}$, Gain = 6dB, unless otherwise specified.)

NEW PRODUCT

1. THD+N vs Output Power

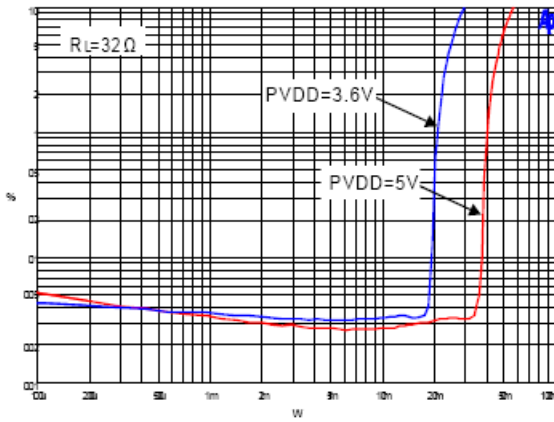

2. THD+N vs Output Power

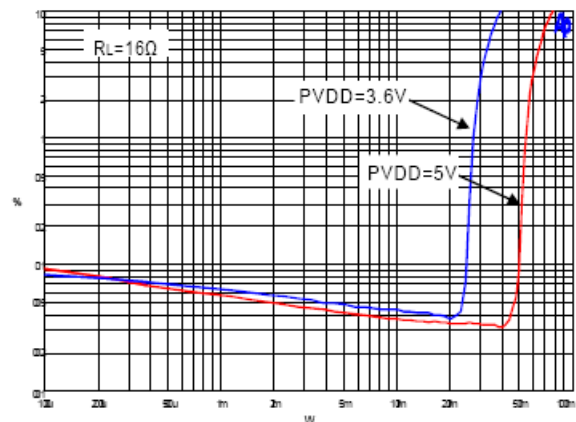

3. THD+N vs Frequency

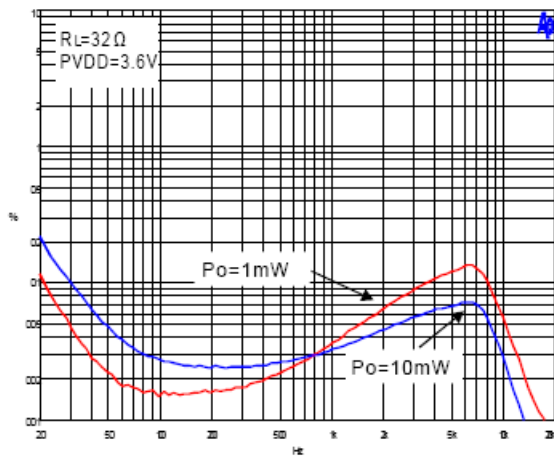

4. THD+N vs Frequency

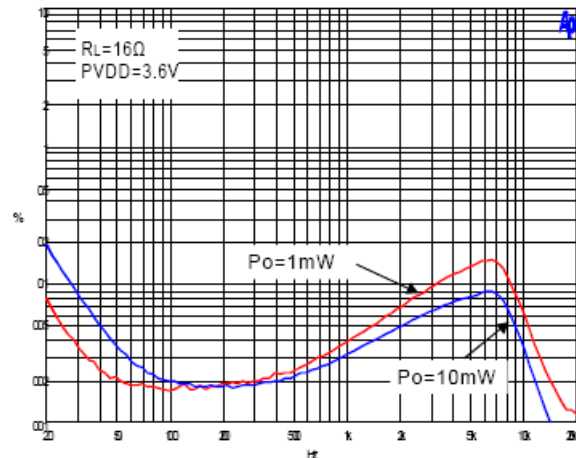

5. Frequency Response

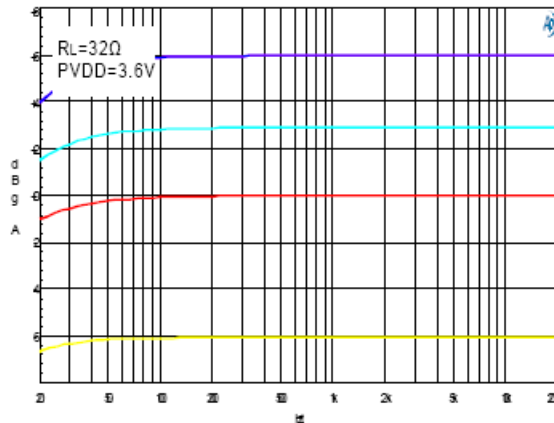

6. Frequency Response

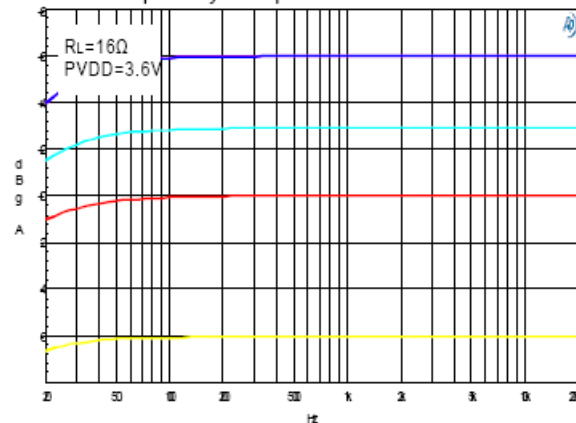

Typical Performance Characteristics (Cont.) (@ $T_A = +25^\circ\text{C}$, $P_{VDD} = 3.6\text{V}$, $f = 1\text{kHz}$, Gain = 6dB, unless otherwise specified.)

NEW PRODUCT

7. Crosstalk

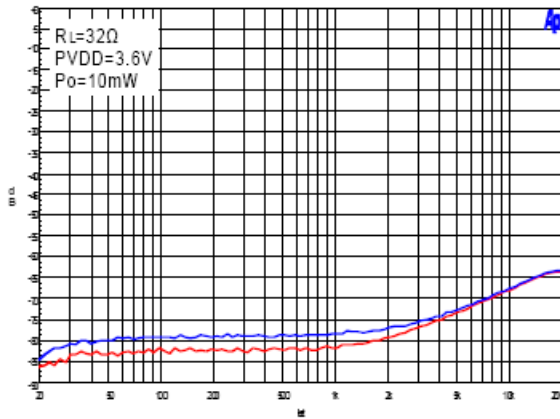

8. Crosstalk

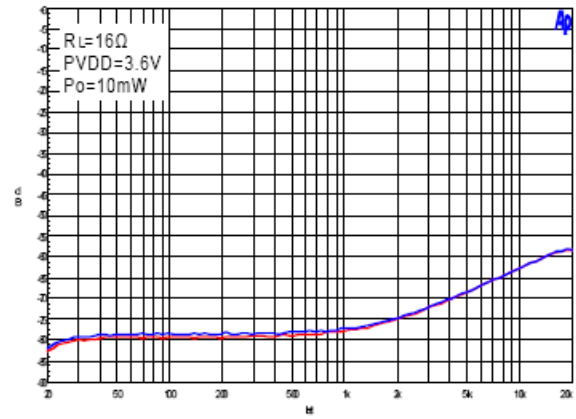

9. PSRR

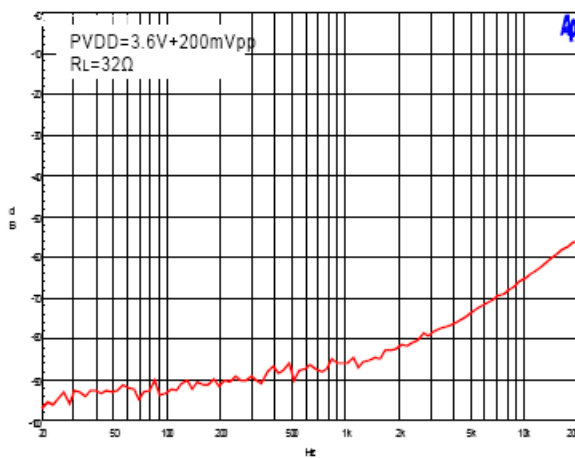

10. PSRR

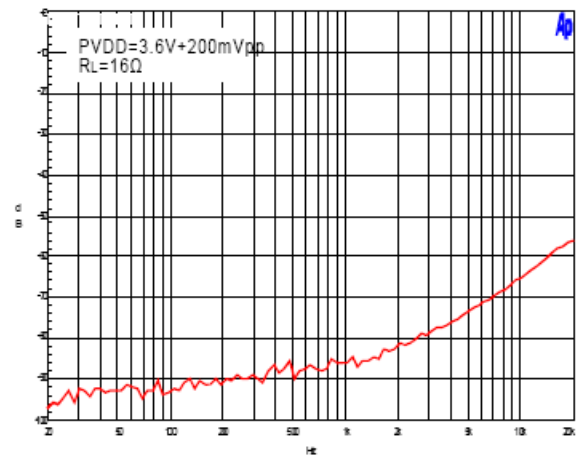

11. FFT Noise

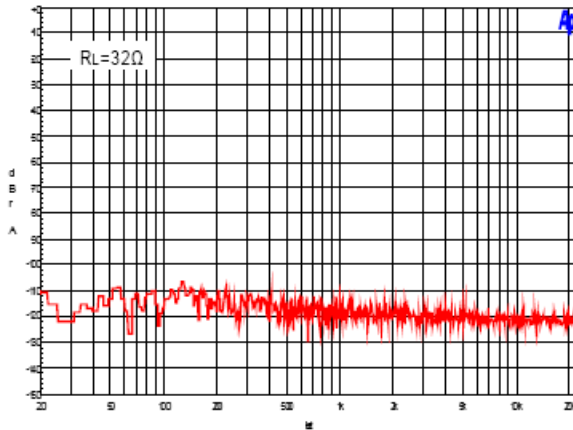

12. FFT Noise

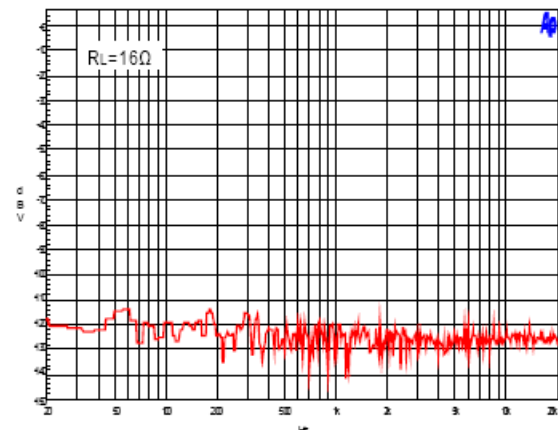

Typical Performance Characteristics (Cont.) (@ $T_A = +25^\circ\text{C}$, $C_{IN} = 10\mu\text{F}$, $C_O = 10\mu\text{F}$, $L = 4.7\mu\text{H}$, unless otherwise specified.)

13. Start up with signal

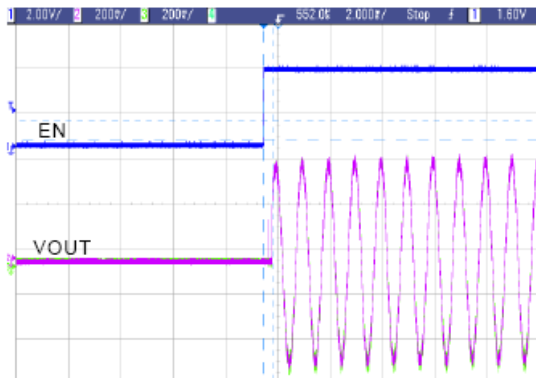

14. Shutdown with signal

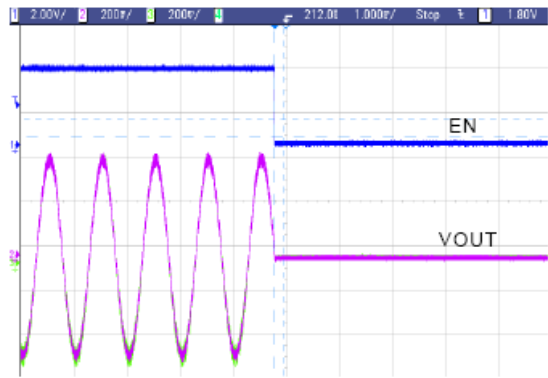

15. Start up without signal

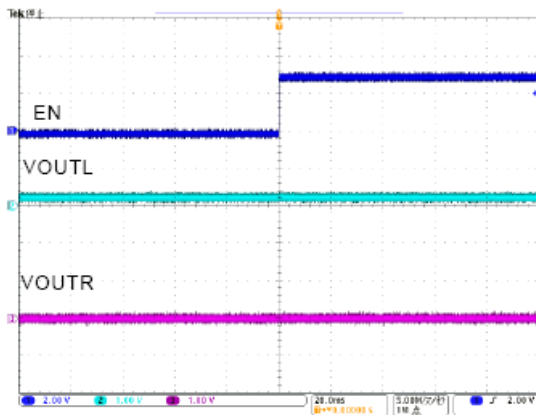

16. Shutdown without signal

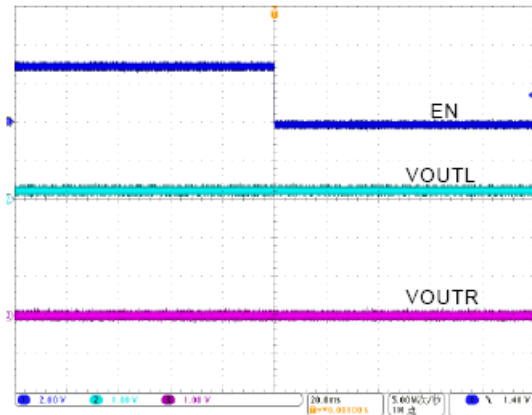

17. Output Voltage vs Supply Voltage

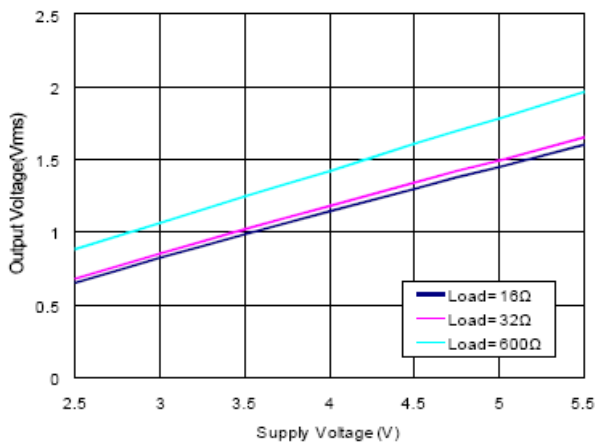

Application Information

The basic PAM8901 / PAM8908 application circuit is shown in page 2.

Gain Control

The PAM8901 / PAM8908 has four gain settings which are controlled with pins G0 and G1. The following table gives an overview of the gain function.

G0 Voltage	G1 Voltage	Amplifier Gain
≤0.6V	≤0.6V	-6dB
≥1.4V	≤0.6V	0dB
≤0.6V	≥1.4V	3dB
≥1.4V	≥1.4V	6dB

Input Coupling Capacitors

Input coupling capacitors block any DC bias from the audio source and ensure maximum dynamic range. Input coupling capacitors also minimize PAM8901 / PAM8908 turn-on pop to an inaudible level. The input capacitors are in series with PAM8901 / PAM8908 internal input resistors, creating a high-pass filter. The following Equation calculates the highpass filter corner frequency.

$$f_c = \frac{1}{2\pi R_{IN} C_{IN}}$$

The input impedance, R_{IN} , is dependent on device gain. Larger input capacitors decrease the corner frequency. See the following table for input impedance values.

G0 Voltage	G1 Voltage	R_{IN}
≤0.6V	≤0.6V	26.4kΩ
≥1.4V	≤0.6V	19.8kΩ
≤0.6V	≥1.4V	16.5kΩ
≥1.4V	≥1.4V	13.2kΩ

For a given high-pass cutoff frequency, the minimum input coupling capacitor is found as:

$$C_{IN} = \frac{1}{2\pi f_c R_{IN}}$$

Example: Design for a 20Hz corner frequency with a PAM8901 / PAM8908 gain of +6dB. The input impedance table gives R_{IN} as 13.2kΩ. The C_{IN} Equation shows the input coupling capacitors must be at least 0.6μF to achieve a 20Hz highpass corner frequency. Choose a 0.68μF standard value capacitor for each PAM8901 / PAM8908 input (X5R material or better is required for best performance).

Charge Pump Flying Capacitor, HPVDD Capacitor and HPVSS Capacitor

The PAM8901 / PAM8908 uses a built-in charge pump to generate a positive and negative voltage supply for the headphone amplifiers. The charge pump flying capacitor connects between CAP+ and CAP-. It transfers charge to generate the positive and negative supply voltage. The HPVDD capacitor or HPVSS capacitor must be at least equal in or larger than value to the flying capacitor to allow maximum charge transfer. Use low equivalent-series-resistance (ESR) ceramic capacitors (X5R material or better is required for best performance) to maximize charge pump efficiency. Typical values are 1μF for the HPVDD, HPVSS and flying capacitors.

Power Supply Decoupling Capacitors

The PAM8901 / PAM8908 TrueCapFree headphone amplifier requires adequate power supply decoupling to ensure that output noise and total harmonic distortion (THD) remain low. Use good low equivalent-series-resistance (ESR) ceramic capacitors (X5R material or better is required for best performance). Place a 2.2μF capacitor within 5mm of the PVDD pin. Reducing the distance between the decoupling capacitor and PVDD minimizes parasitic inductance and resistance, improving PAM8901 / PAM8908 supply rejection performance. Use 0402 or smaller size capacitors if possible.

Application Information (Cont.)

Power Supply Sequencing

Use input coupling capacitors to ensure inaudible turn-on pop. Activate the PAM8901 / PAM8908 after all audio sources have been activated and their output voltages have settled. On powerdown, deactivate the PAM8901 / PAM8908 before deactivating the audio input source. The EN pin controls device shutdown: Set to 0.6V or lower to deactivate the PAM8901 / PAM8908; set to 1.4V or higher to activate.

TrueCapFree Headphone Amplifiers

The TrueCapFree amplifier architecture operates from a single supply voltage and uses two internal charge pumps to generate a positive supply and a rail for the headphone amplifier. The output voltages are centered around 0V and are capable of positive and negative voltage swings as shown in the following drawing.

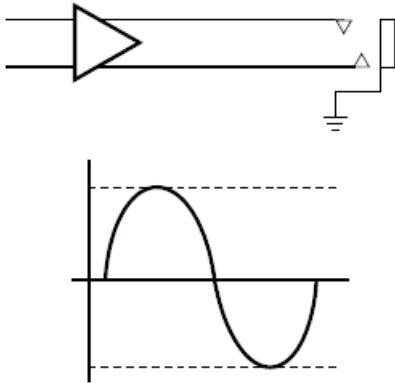

TrueCapFree amplifiers require no output DC-blocking capacitors. The headphone connector shield pin connects to ground and will interface with headphones and non-headphone accessories. The PAM8901 / PAM8908 is a TrueCapFree amplifier.

LAYOUT RECOMMENDATIONS

Exposed Pad on PAM8901 / PAM8908

Solder the exposed metal pad on the PAM8901 / PAM8908 U-QFN3030-16 (Type US) package to the landing pad on the PCB. Connect the landing pad to ground or leave it electrically unconnected (floating). Do not connect the landing pad to PVDD or to any other power supply voltage. If the pad is grounded, it must be connected to the same ground as the PGND. Soldering the thermal pad is required for mechanical reliability and enhances thermal conductivity of the package.

GND Connections

The SGND pin is an input reference and must be connected to the headphone ground connector pin. This ensures no turn-on pop and minimizes output offset voltage. Do not connect more than $\pm 0.3V$ to SGND.

PGND is a power ground. Connect supply decoupling capacitors for PVDD, HPVDD, and HPVSS to PGND.

Power Supply Connections

Connect the supply voltage to the PVDD pin and decouple it with an X5R or better capacitor. Place both PVDD capacitors within 5mm of PVDD pin on the PAM8901 / PAM8908. Ensure that the ground connection of PVDD capacitor has a minimum length return path to the device. Failure to properly decouple the PAM8901 / PAM8908 may degrade audio or EMC performance.

Ordering Information

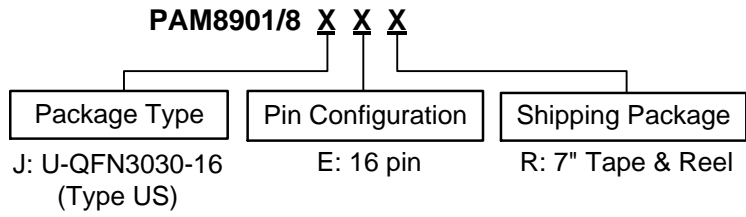

Part Number	Package Type	Standard Package
PAM8901JER	U-QFN3030-16 (Type US)	3000 Units/ Tape & Reel
PAM8908JER	U-QFN3030-16 (Type US)	3000 Units/ Tape & Reel

Marking Information

(Top View)

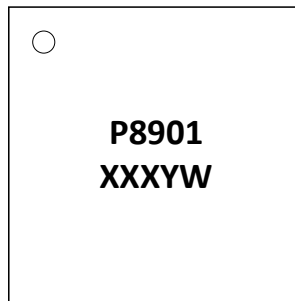

U-QFN3030-16 (Type US)

XXX : Internal Code
Y: Year
W: Weak

(Top View)



U-QFN3030-16 (Type US)

XXX : Internal Code
Y: Year
W: Weak

Package Outline Dimensions

Please see <http://www.diodes.com/package-outlines.html> for the latest version.

U-QFN3030-16 (Type US)

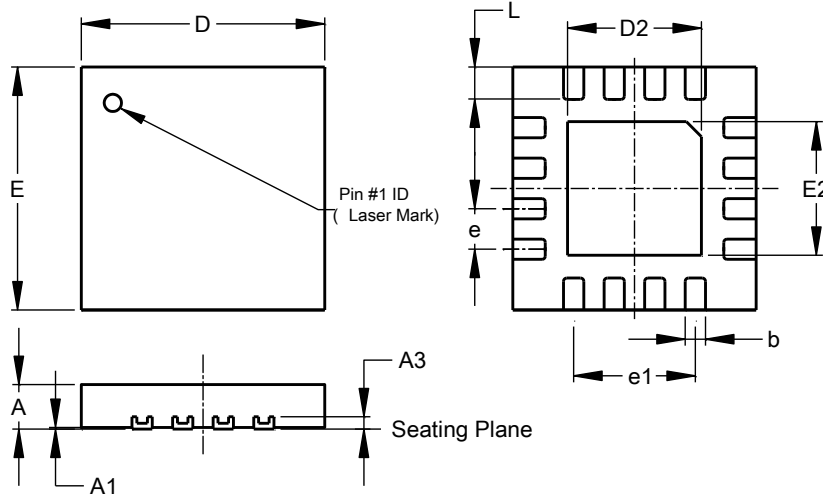

U-QFN3030-16 (Type US)			
Dim	Min	Max	Typ
A	0.500	0.600	0.550
A1	0.000	0.050	--
A3	0.152 REF		
b	0.200	0.300	0.250
D	2.950	3.050	3.000
D2	1.600	1.700	1.650
e	0.500 BSC		
e1	1.500 REF		
E	2.950	3.050	3.000
E2	1.600	1.700	1.650
L	0.350	0.450	0.400
All Dimensions in mm			

Suggested Pad Layout

Please see <http://www.diodes.com/package-outlines.html> for the latest version.

U-QFN3030-16 (Type US)

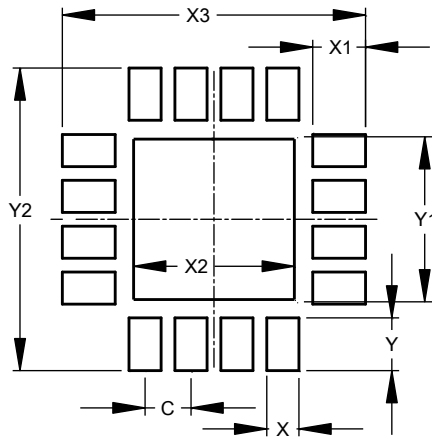

Dimensions	Value (in mm)
C	0.500
X	0.350
X1	0.570
X2	1.800
X3	3.300
Y	0.570
Y1	1.800
Y2	3.300

IMPORTANT NOTICE

DIODES INCORPORATED MAKES NO WARRANTY OF ANY KIND, EXPRESS OR IMPLIED, WITH REGARDS TO THIS DOCUMENT, INCLUDING, BUT NOT LIMITED TO, THE IMPLIED WARRANTIES OF MERCHANTABILITY AND FITNESS FOR A PARTICULAR PURPOSE (AND THEIR EQUIVALENTS UNDER THE LAWS OF ANY JURISDICTION).

Diodes Incorporated and its subsidiaries reserve the right to make modifications, enhancements, improvements, corrections or other changes without further notice to this document and any product described herein. Diodes Incorporated does not assume any liability arising out of the application or use of this document or any product described herein; neither does Diodes Incorporated convey any license under its patent or trademark rights, nor the rights of others. Any Customer or user of this document or products described herein in such applications shall assume all risks of such use and will agree to hold Diodes Incorporated and all the companies whose products are represented on Diodes Incorporated website, harmless against all damages.

Diodes Incorporated does not warrant or accept any liability whatsoever in respect of any products purchased through unauthorized sales channel. Should Customers purchase or use Diodes Incorporated products for any unintended or unauthorized application, Customers shall indemnify and hold Diodes Incorporated and its representatives harmless against all claims, damages, expenses, and attorney fees arising out of, directly or indirectly, any claim of personal injury or death associated with such unintended or unauthorized application.

Products described herein may be covered by one or more United States, international or foreign patents pending. Product names and markings noted herein may also be covered by one or more United States, international or foreign trademarks.

This document is written in English but may be translated into multiple languages for reference. Only the English version of this document is the final and determinative format released by Diodes Incorporated.

LIFE SUPPORT

Diodes Incorporated products are specifically not authorized for use as critical components in life support devices or systems without the express written approval of the Chief Executive Officer of Diodes Incorporated. As used herein:

A. Life support devices or systems are devices or systems which:

1. are intended to implant into the body, or
2. support or sustain life and whose failure to perform when properly used in accordance with instructions for use provided in the labeling can be reasonably expected to result in significant injury to the user.

B. A critical component is any component in a life support device or system whose failure to perform can be reasonably expected to cause the failure of the life support device or to affect its safety or effectiveness.

Customers represent that they have all necessary expertise in the safety and regulatory ramifications of their life support devices or systems, and acknowledge and agree that they are solely responsible for all legal, regulatory and safety-related requirements concerning their products and any use of Diodes Incorporated products in such safety-critical, life support devices or systems, notwithstanding any devices- or systems-related information or support that may be provided by Diodes Incorporated. Further, Customers must fully indemnify Diodes Incorporated and its representatives against any damages arising out of the use of Diodes Incorporated products in such safety-critical, life support devices or systems.

Copyright © 2016, Diodes Incorporated

www.diodes.com

Looking for pricing, stock, or lifecycle information?

Click below to explore more details on WIN SOURCE:

 [View PAM8901JER on WIN SOURCE](#)

 [Diodes Incorporated](#) Information

Optimize Your Supply Chain with WIN SOURCE Solutions

-  Global Sourcing Solution
-  Obsolete Management
-  Cost Control Management
-  Shortage Management
-  Alternative Solution
-  Excess Inventory Management