

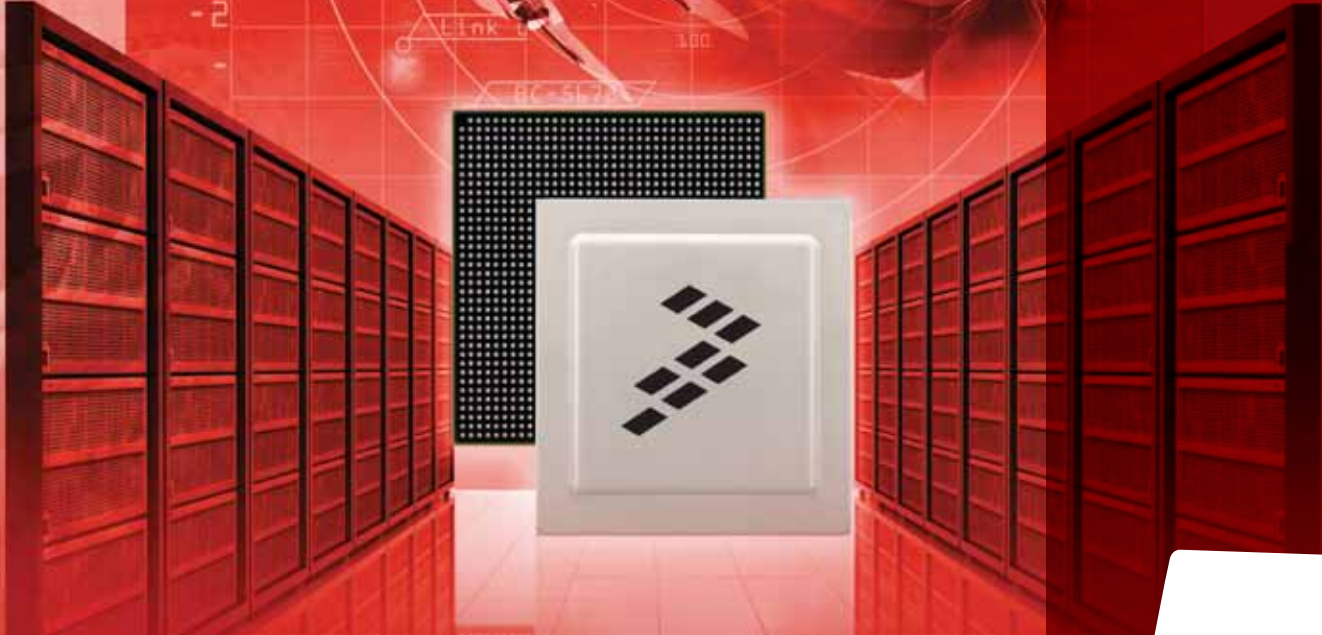

**THE DATASHEET OF
P2041NSN7PNC**





Application Brief

QorIQ P2040/P2041, P3 and P5 Series

High-performance
multicore processors



freescale.com/QorIQ



QorIQ Communications Platform: Scalable Processing Performance

Ideal for networking infrastructure, telecom, industrial control, storage, control plane, aerospace/defense and test and measurement applications, Freescale QorIQ communications platforms are the next-generation evolution of our leading PowerQUICC communications processors. Based on high-performance e500mc and e5500 cores built on Power Architecture® technology, QorIQ platforms enable a new era of networking innovation that meets reliability, security and quality-of-service needs for the most demanding networking and industrial applications.

We have expanded the performance range of the QorIQ communications processor product lines with the introduction of the quad-core QorIQ P2040/P2041 and P3 platforms, and the 64-bit QorIQ P5 platform. These processors deliver unprecedented performance power for a wide variety of applications.

The new QorIQ P2040/P2041 and P3041 processors expand the reach of the Freescale P4 platform into lower power applications. Manufactured in 45 nm silicon-on-insulator process technology, these processors offer optimal integration and new intellectual property that delivers improved functionality for end products. The P2040/P2041 and P3041 processors integrate four e500mc cores based on Power Architecture technology running up to 1.5 GHz within 12 watts, and deliver about 2.5 DMIPS/MHz. Key features include a three-level cache hierarchy for optimized latencies, a hardware hypervisor for robust support of multiple operating systems within the device, a trusted boot architecture to ensure code is not tampered with or reverse engineered and efficient data path handling in the form of the Data Path Acceleration Architecture (DPAA).

The P5 family of processors offers our highest single-threaded performance for next-generation embedded control plane

applications. With frequencies scaling to 2.4 GHz, the P5040 delivers an impressive 28,800 DMIPs in 25 watts typical power. The 64-bit e5500 core enables customers to address up to 64 GB of flat memory space, eliminating the 4 GB memory limitation in 32-bit architecture, and provides customers with 64-bit capabilities that are important in computational intensive applications such as image processing, security and statistical computing. The P5 devices are capable of pin compatibility with each other and also with the P4 and P3 devices. This enables seamless roadmap scaling from mid-range quad cores to high-end octals to high-end duals.

Manufactured in 45 nm process technology, the P5040, P5021, P5020 and P5010 devices integrate a RAID 5/6 engine to accelerate parity calculations for storage applications, making it ideal for enterprise storage area networks (SAN) and enterprise network attached storage (NAS) solutions.

The P5020, P3041, P2040 and P2041 all support Serial RapidIO (V1.3 + 2.1) for higher bandwidth and a message manager to support Type 9 (data streaming) and improved Type 11 (messaging) transactions. The P5 and P3 families and the P204x support integrated serial advanced technology attachment (SATA) 2.0, PCI-E Gen 2 controllers, 10 Gigabit Ethernet, 1 Gigabit Ethernet with support for 1.0 and 2.5 Gb/s SGMII and two USB 2.0 with integrated PHYs to provide a highly integrated, high-performance processor ideal for networking, industrial and data center applications.

The QorIQ P2041 and P2040 processors are similar to the P3041 but have a lower cost, power, performance and functionality. These devices are pin compatible.

The DPAA is common across this product line, as well as some members of the P1 family (such as the P1023 and P1027). As a result, products in all five levels of the QorIQ family are software compatible, enabling easy migration across a range of applications, scaling from consumer pizza boxes to core routers.

P2040/P2041, P3041 Key Features and Benefits

| Key Features | Benefits |
|--------------------------------------|--|
| Four high-performance cores | <ul style="list-style-type: none"> Supports flexible allocation of resources to control and data plane, with hypervisor enabling robust AMP implementation Up to 1.5 GHz cores enable high-performance control plane |
| High-performance acceleration | <ul style="list-style-type: none"> DPAA offloads CPU for upper layer functions |
| Trust architecture | <ul style="list-style-type: none"> Key to establishing a trusted secure system Prevents unauthorized code from being run on a system Key to clone prevention |
| Flexible SerDes configuration | <ul style="list-style-type: none"> Many options for multiplexing across PCIe, SGMII, 2.5 Gb/s SGMII, XAUI, SRIO, SATA |
| Serial RapidIO improvements | <ul style="list-style-type: none"> Supporting up to 5 GHz for high control and data throughput RapidIO® message manager (RMan) allows packets (Type 9 and 11) to plug directly into DPAA for greater CPU offload |
| Dual SATA | <ul style="list-style-type: none"> Board cost savings by integrating high-capacity disk storage interface |

P5 Key Features and Benefits

| Features | Benefits |
|--|--|
| 64-bit e5500 core | <ul style="list-style-type: none"> Up to 64 GB addressable memory space Supports up to 2.2 GHz CPU frequency, capable of scaling up to 2.4 GHz Hybrid 32-bit mode to support legacy software and transition to 64-bit architecture |
| Application-specific accelerators | <ul style="list-style-type: none"> DPAA offloads the cores from the need to perform common packet-handling tasks RAID5/6 calculates parity for network attached storage and direct attached storage applications Optimum performance/power |
| Intelligent integration | <ul style="list-style-type: none"> Integrated memory controllers XAUI, SGMII, PCI Express, SATA and Aurora high-speed interconnects Multiple 1 GigE and 10 GigE |
| Hardware hypervisor | <ul style="list-style-type: none"> Enables safe and autonomous operation of multiple individual operating systems Facilitates resource sharing and partitioning |
| Trusted boot | <ul style="list-style-type: none"> Secure boot ensures that the system begins executing trusted code Key to establishing a trusted secure system |
| Scalable processor family | <ul style="list-style-type: none"> Ability to supply from single-core to quad-core devices in pin-compatible packages “Future-proof” support by allowing today’s single core applications to seamlessly scale to dual- and quad-core support for subsequent generations Allows applications to take advantage of 64-bit core performance while maintaining critical power budgets |

Networking

Many changes have occurred in the networking infrastructure market over the last few years—and many more are coming. In recent years, major advances in information communication technologies, combined with the rapid growth of global networks such as the Internet, have transformed businesses and markets. The network is the foundation of every IT infrastructure, and as a result, many enterprises are now investing in new business applications and services that expand the use and reliability of the network and play a critical role in day-to-day operations, creating significant wealth and economic growth worldwide. This growth has been made possible by the combination of dramatic increases in the power and versatility of technologies, with significantly reduced costs and creative application of tools and networks in all aspects of the economy and society. Claiming the number 1 position for wired and wireless markets with over 300 million communications processors shipped, Freescale is leading innovation in next-generation networking infrastructure. With Power Architecture technology-based devices including PowerQUICC and QorIQ communications platforms, our networking portfolio is unmatched in breadth. Combined with our enablement ecosystem and strategic alliance partners, we can help you build full system solutions in the pursuit of a smarter, more connected world.

To meet demand for high-performance and power-conscious applications while providing a roadmap for the next-generation networking embedded market, Freescale provides—in its broad portfolio of industry-leading QorIQ P2040/P2041, P3041 and P5 series processors—excellent features for networking applications, combining higher CPU performance with hardware hypervisor for robust virtualization support and DPAA, while the PCI Express, DDR3/3L and SRIO interfaces offer versatility and convenience. Networking applications also enjoy the benefits of dual SATA ports, providing high-speed, cost-effective storage options for statistics or large databases, and 2.5 Gb/s SGMII Ethernet interfaces, enabling the next step in performance connectivity to switches.

freescale.com/QorIQ



Integrated Access Router (IAD)

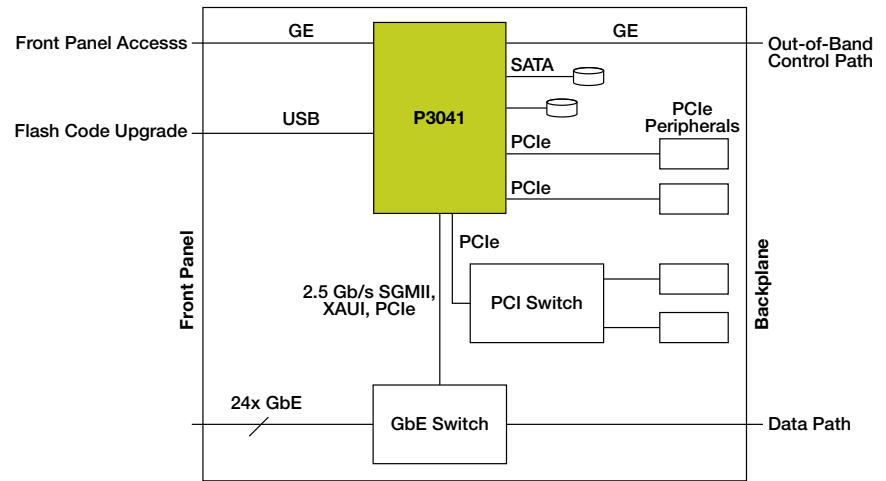

Freescale Technology

Applications

- Integrated access routers
- Enterprise switching
- Line cards combined control and data plane
- Security gateways
- Universal threat management security appliances
- SSL, IPSec, firewall

Market Features

- Dual SATA ports provide high-speed, cost-effective storage options for statistics or large databases
- Hypervisor support for safe partitioning of control and data plane
- 2.5 Gb/s Ethernet enables the next step in performance connectivity to switches
- Efficient core means less processing power is required
- SEC and PME for value-added services
- Broad range of third-party embedded OS supported
- Trusted boot for IP protection
- PCI Express interfaces enable multiple flexible I/O options
- Long product life cycles

Storage

The rapid expansion of high-performance information processing and transmission among millions of applications has fueled the growth of the storage market. As well as supporting a brisk growth rate, the storage market is continually diversifying to serve emerging markets. Market drivers include:

- Rapidly increasing volumes of business data that need secure storage, including email, web content, video and other e-business material
- Disaster recovery from power outages, fires and severe natural calamities
- Government regulations, such as notification and retention policies
- Explosive growth in sophisticated home information, communication and entertainment systems
- Increased downloads of personal and premium content within the home network

Freescale supplies embedded processor solutions to address the integrated performance needs in three storage market areas: SAN, NAS and digital media server. These solutions range from high-performance host processors to cost-optimized SoC architectures with integrated redundant array of independent drives (RAID), engines and SATA interfaces.

Servicing enterprise and small/medium business markets, SAN systems require high-performance processors with high I/O bandwidth and increased PCIe performance. The host processor controls data movement from the network to RAID ASICs, TCP/IP or iSCSI protocol offload and provides virtualization support and management control. The P5 family of processors offer a RAID 5/6 accelerator for use in SAN and NAS. The RAID 5/6 accelerator performs the parity calculation using a configurable Galois field polynomial and supports a data integrity field, making it ideal for use in high-performance, high-reliability storage applications.



SAN RAID Controller

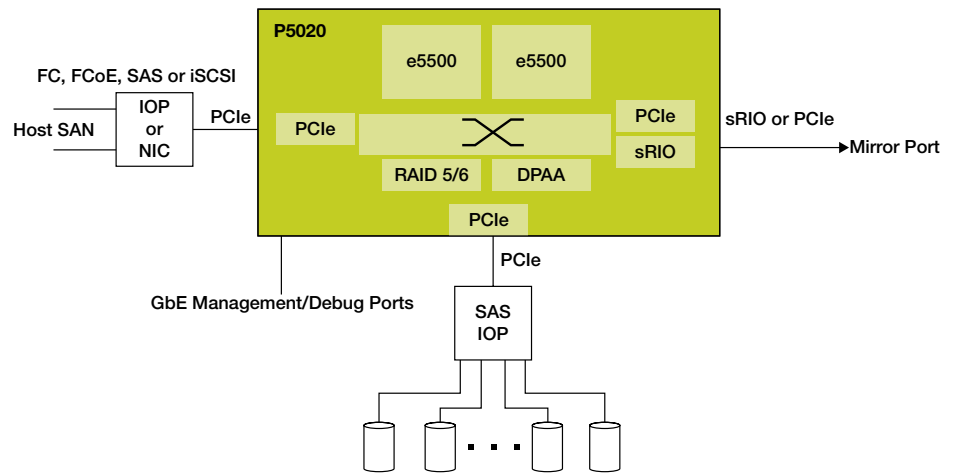

Freescale Technology

Applications

- SAN
- Enterprise NAS
- Unified storage

Market Features

- RAID 5/6 accelerator
- Integrated dual SATA interface
- High-speed line rate GbE and 10 GbE networking
- High-speed memory
- High levels of SoC integration
- DPAA
- Broad range of third-party embedded OS supported

Telecommunications

Telecommunications is one of the fastest growing industries in the world. Telecommunications carriers are expanding their data transmission capabilities by replacing copper wires with fiber optic cables. In some areas, carriers are extending fiber optic cable to residential customers, enabling them to offer cable television, video-on-demand, faster high-speed Internet and conventional telephone communications over a single line.

The growth and innovation of the telecom industry has enabled people to communicate across the globe and access endless amounts of information over the Internet.

Broadband services are becoming faster and easier to access with fiber-optic networks and wireless services like WiMax and LTE. These technologies allow faster data transmission and better Internet access in an effort to make wireless Internet carriers more competitive in a market that includes wired technologies. With faster connection speeds, wireless carriers can transmit music, videos, applications and other content that can be downloaded and played on cellular phones, giving users mobile access to large amounts of data. In addition, as use of this mobile technology increases, wireless companies continue to develop the next generation of technologies that will allow even faster data transmission.

To help meet today's demanding requirements, telecommunication solutions must provide greater intelligence, higher bandwidth, wide connectivity, scalability and faster time to market. The P2040/P2041 and P3041 processors integrate the features and performance required to meet the needs of telecommunication applications, including SGMII and PCIe to reduce system interconnect costs. In addition, Freescale offers dual Serial RapidIO ports (up to 5 GHz) which can be used for redundancy or multiple connections, both to the backplane or the DSP farm. With improved Type 11 messaging and new support for Type 9 data streaming, the Serial RapidIO interconnect can now be used as a control plane interface and to achieve its intended potential as a highly efficient data path.



Base Station

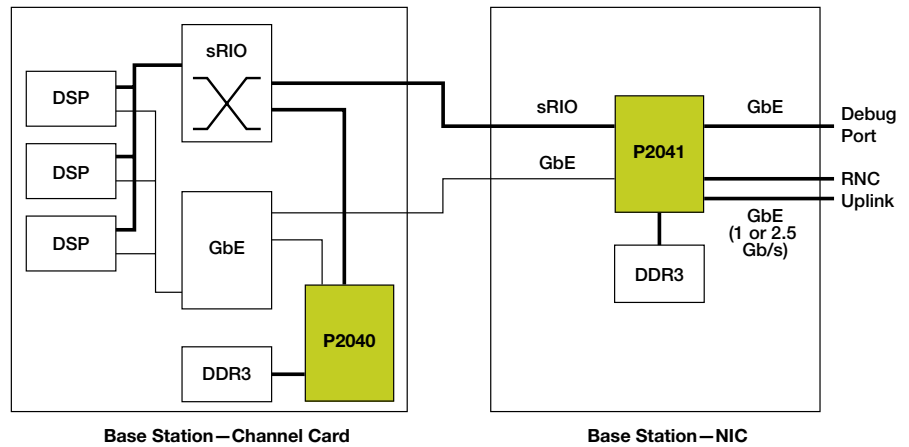

Freescale Technology

Applications

- LTE/WiMax base stations
 - Channel cards
 - Network interface cards (NIC)
- General-purpose compute blades

Market Features

- Dual Serial RapidIO ports (up to 5 GHz) for redundancy or multiple connections
- Type 9 and 11 messaging in the SRIO interfaces for DSP connectivity
- Integration of control and data plane on single multicore with hardware-assisted application acceleration
- Encryption for Kasumi, Snow3G and IPSec
- Support of dominant DDR3/3L memory
- Integrated SerDes reduces system interconnect costs
- Four e500mc cores running up to 1.5 GHz provide computing power needed for high-performance and compute-intensive applications

Industrial

In today's industrial market, new technology provides many opportunities for system developers to successfully address ever-evolving challenges. Freescale delivers embedded industrial solutions engineered to meet the environmental, longevity and energy efficiency requirements of connected industrial applications. We are fulfilling our industrial customers' needs to meet the growing requirements for more intelligent and cost-effective industrial solutions for the industrial control and networking, defense and aerospace, test and measurement, robotics and control plane markets.

Aerospace and Defense

With human lives at stake, devices must be reliable, durable and efficient in aerospace and defense applications. QorIQ processors meet the performance, safety and security criteria mandated by these markets. QorIQ P5 devices deliver highly integrated solutions that combine high-speed I/O, multiple memory controllers and secure boot options as well as a sophisticated security engine to help designers reduce space, weight and power while ensuring security within their application.

We understand that time in market is as important as time to market. Through our Product Longevity Program, QorIQ processors provide the 10+ year lifetime required for these applications. We are committed to continue technology advancements, providing cost-effective, reliable, field-proven solutions for the defense and commercial aerospace markets.

Robotics

Today, robots are in widespread use, performing jobs more reliably, accurately and more cost effectively than humans. As technology becomes more complex and refined, many industrial applications require increasing intelligence. Through the use of precisely controlled mechanisms, sophisticated robotics perform tasks either autonomously or networked with other systems. Robots are provided with large amounts of data which is processed with computation-intensive algorithms. Multitasking embedded solutions—providing high levels of real-time computing performance—are needed to fulfill robotic application requirements.



Control Plane Processor for a Router

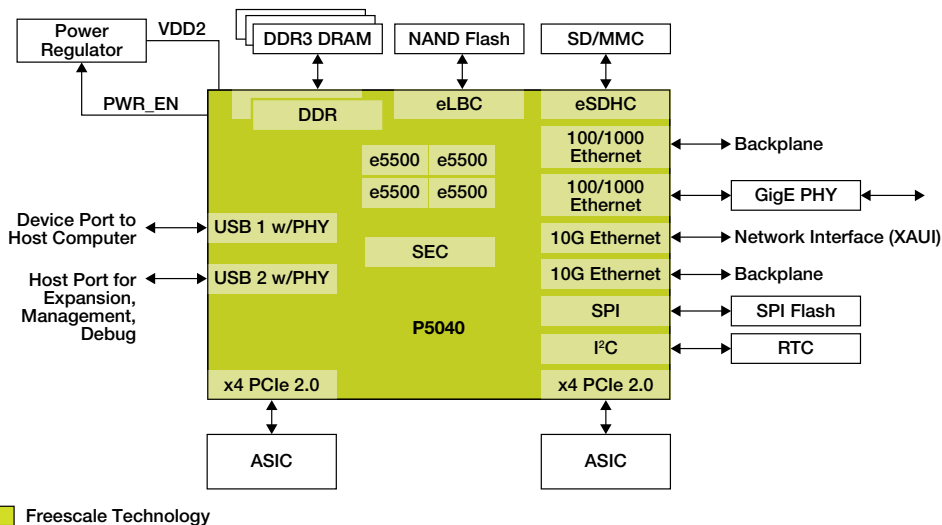

Built using high-performance Power Architecture cores, the P2040/P2041, P3041 and P5 series of processors are well suited for computationally intensive industrial and consumer applications.

Applications

- Factory automation
- Robotics
- Test and measurement
- Defense and aerospace
- Multifunction printers
- Embedded board solutions
- Control plane

Market Features

- High-performance classic double-precision floating point unit
- Dual Serial RapidIO port support for redundant backplanes (not on P5040/21)
- High-frequency, seven-stage pipeline processors
- Hardware hypervisor
- IEEE® 1588 support for nanosecond-level clock accuracy
- Control and networking processing for factory automation gateways
- UART interfaces with support for RS232 and RS485 for legacy serial interfaces with prevalence on factory floor
- Long product life cycles
- Broad range of third-party embedded OS support

QorIQ Family

| | P2040/P2041 | P3041 | P5020/P5010 | P5040/P5021 |
|----------------------------|---|---|--|--|
| CPU frequency range | 667–1500 MHz | 1200–1500 MHz | 1600–2000 MHz | 1800–2400 MHz |
| MIPS | 12,000/15,000 | 15,000 | 6,000/12,000 | 10,800/28,800 |
| Cache (I/D) | 32/32 KB | 32/32 KB | 32/32 KB | 32/32 KB |
| Cache L2 | N/A (P2040) /128 KB/core (P2041) | 128 KB/core | 512 KB/core | 512 KB/core |
| Cache L3 | 1 MB | 1 MB | 2 MB | 2 MB |
| DDR controller | 64-bit DDR3/3L | 64-bit DDR3/3L | Dual 64-bit DDR3/3L | Dual 64-bit DDR3/3L |
| DDR data rate (GHz) | 1.2/1.333 GHz | 1.333 GHz | 1.333 GHz | Up to 1.6 GHz |
| PCI Express | 3 gen 2.0 | 4 gen 2.0 | 4 gen 2.0 | 3 gen 2.0 |
| USB 2.0 | 2 | 2 | 2 | 2 |
| SATA 2.0 | 2 | 2 | 2 | 2 |
| SRIO 1.3 + 2.1 | 2 | 2 | 2 | N/A |
| GbE | 5 x GbE/5 x GbE, 1 x 10 GbE | 5 x GbE, 1 x 10 GbE | 5 x GbE, 1 x 10 GbE | 10 x 1 GbE, 2 x 10 GbE |
| SerDes | 10 lanes @ 5 GHz | 18 lanes @ 5 GHz | 18 lanes @ 5 GHz | 20 lanes @ 5 GHz |
| FPU | Double precision | Double precision | Double precision (IEEE 754 compliant) | Double precision (IEEE 754 compliant) |
| Accelerators | Data path: SEC 4.2, PME 2.1, RMan | Data path: SEC 4.2, PME 2.1, RMan | Data path: SEC 4.2, PME 2.1, RMan, RAID 5/6 | Data path: SEC 5.0, RAID 5/6 |
| Package | 780 FCPBGA | 1295 FCPBGA | 1295 FCPBGA | 1295 FCPBGA |
| Process technology | 45 nm SOI | 45 nm SOI | 45 nm SOI | 45 nm SOI |
| Estimated max power | 12.7/18.2 W | 18.2 W | <30 W | <45 W |
| Other features | SPI, 4 x I ² C, 2 x DUART, CoreNet, SD/MMC, DMA, hardware hypervisor | SPI, 4 x I ² C, 2 x DUART, CoreNet, SD/MMC, DMA, hardware hypervisor | SPI, 4 x I ² C, 2 x DUART, CoreNet, SD/MMC, DMA, hardware hypervisor, IFC | SPI, 4 x I ² C, 2 x DUART, CoreNet, SD/MMC, DMA, hardware hypervisor, IFC |



Freescale Technical Support

Freescale prides itself on world-class support. Assistance is available at freescale.com/support.

Technical Information Center

The engineers in our Technical Information Center offer assistance via phone or online to meet the specific needs of customers around the world.

Local Technical Support

Our Field Application Engineers are located close to our direct customers and are available for direct contact and visits to customer sites.

FAQs

Our vast knowledge base of frequently asked questions (FAQs) is online to offer support 24 hours a day, seven days a week and is updated and maintained by product experts.

Technical Documents

Available at freescale.com.

- Engineering bulletins
- Reference manuals
- Data sheets

Freescale Forums

Our forums are moderated by product experts and feature discussions on Freescale MCUs and development tools, allowing you to communicate your ideas on a global scale.

This brochure is not intended to represent the entire Freescale portfolio of QorIQ products. Contact us to discuss what we can do for your application.

For additional information about Freescale QorIQ communications processors, please visit freescale.com/QorIQ



Looking for pricing, stock, or lifecycle information?

Click below to explore more details on WIN SOURCE:

 [View P2041NSN7PNC on WIN SOURCE](#)

 [NXP / Nexperia Information](#)

Optimize Your Supply Chain with WIN SOURCE Solutions

-  Global Sourcing Solution
-  Obsolete Management
-  Cost Control Management
-  Shortage Management
-  Alternative Solution
-  Excess Inventory Management