



**THE DATASHEET OF  
OPA4277MDTEP**



## OPA4277-EP High Precision Operational Amplifier

### 1 Features

- Ultra-Low Offset Voltage: 10  $\mu\text{V}$
- Ultra-Low Drift:  $\pm 0.1 \mu\text{V}/^\circ\text{C}$
- High Open-Loop Gain: 134 dB
- High Common-Mode Rejection: 140 dB
- High-Power Supply Rejection: 130 dB
- Low Bias Current: 1-nA Max
- Wide Supply Range:  $\pm 2$  to  $\pm 18$  V
- Low Quiescent Current: 800  $\mu\text{A}$ /Amplifier
- Supports Defense, Aerospace, and Medical Applications
  - Controlled Baseline
  - One Assembly and Test Site
  - One Fabrication Site
  - Available in Military ( $-55^\circ\text{C}$  to  $125^\circ\text{C}$ ) Temperature Range
  - Extended Product Life Cycle
  - Extended Product-Change Notification
  - Product Traceability

### 2 Applications

- Transducer Amplifier
- Bridge Amplifier
- Temperature Measurements
- Strain Gage Amplifier
- Precision Integrator
- Battery Powered Instruments
- Test Equipment

### 3 Description

The OPA4277-EP precision operational amplifier replaces the industry standard OP-177. It offers improved noise, wider output voltage swing, and is twice as fast with half the quiescent current. Features include ultra-low offset voltage and drift, low bias current, high common-mode rejection, and high power supply rejection.

The OPA4277-EP operates from  $\pm 2$ - to  $\pm 18$ -V supplies with excellent performance. Unlike most operational amplifiers which are specified at only one supply voltage, the OPA4277-EP precision operational amplifier is specified for real-world applications; a single limit applies over the  $\pm 5$ - to  $\pm 15$ -V supply range. High performance is maintained as the amplifier swings to the specified limits. Because the initial offset voltage ( $\pm 20$ - $\mu\text{V}$  max) is so low, user adjustment is usually not required.

The OPA4277-EP is easy to use and free from phase inversion and overload problems found in some operational amplifiers. It is stable in unity gain and provides excellent dynamic behavior over a wide range of load conditions. The OPA4277-EP features completely independent circuitry for lowest crosstalk and freedom from interaction, even when overdriven or overloaded.

#### Device Information<sup>(1)</sup>

PART NUMBER	PACKAGE	BODY SIZE (NOM)
OPA4277MDTEP	SOIC (14)	3.91 mm x 8.65 mm

(1) For all available packages, see the orderable addendum at the end of the data sheet.

#### Simplified Schematic

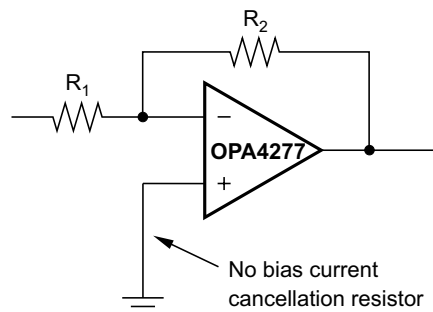

## Table of Contents

<b>1 Features</b> .....	<b>1</b>	7.2 Functional Block Diagram .....	<b>10</b>
<b>2 Applications</b> .....	<b>1</b>	7.3 Feature Description .....	<b>10</b>
<b>3 Description</b> .....	<b>1</b>	<b>8 Application and Implementation</b> .....	<b>11</b>
<b>4 Revision History</b> .....	<b>2</b>	8.1 Application Information .....	<b>11</b>
<b>5 Pin Configuration and Functions</b> .....	<b>3</b>	8.2 Typical Application .....	<b>11</b>
<b>6 Specifications</b> .....	<b>4</b>	<b>9 Power Supply Recommendations</b> .....	<b>14</b>
6.1 Absolute Maximum Ratings .....	<b>4</b>	<b>10 Layout</b> .....	<b>14</b>
6.2 Handling Ratings .....	<b>4</b>	10.1 Layout Guidelines .....	<b>14</b>
6.3 Recommended Operating Conditions .....	<b>4</b>	10.2 Layout Example .....	<b>15</b>
6.4 Thermal Information .....	<b>4</b>	<b>11 Device and Documentation Support</b> .....	<b>16</b>
6.5 Electrical Characteristics .....	<b>5</b>	11.1 Trademarks .....	<b>16</b>
6.6 Typical Characteristics .....	<b>6</b>	11.2 Electrostatic Discharge Caution .....	<b>16</b>
<b>7 Detailed Description</b> .....	<b>10</b>	11.3 Glossary .....	<b>16</b>
7.1 Overview .....	<b>10</b>	<b>12 Mechanical, Packaging, and Orderable Information</b> .....	<b>16</b>

## 4 Revision History

DATE	REVISION	NOTES
November 2014	*	Initial release.

## 5 Pin Configuration and Functions

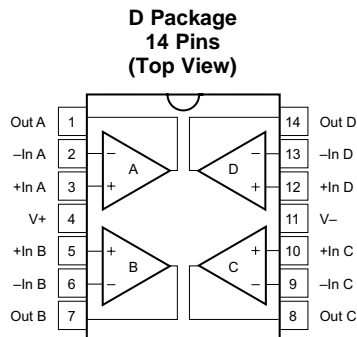

**Pin Functions**

PIN		I/O	DESCRIPTION
NAME	NO.		
OUT A	1	O	Amplifier output A
-IN A	2	I	Inverting amplifier input A
+IN A	3	I	Noninverting amplifier input A
V+	4	P	Positive amplifier power supply input
+IN B	5	I	Noninverting amplifier input B
-IN B	6	I	Inverting amplifier input B
OUT B	7	O	Amplifier output B
OUT C	8	O	Amplifier output C
-IN C	9	I	Inverting amplifier input C
+IN C	10	I	Noninverting amplifier input C
V-	11	P	Negative amplifier power supply input
+IN D	12	I	Noninverting amplifier input D
-IN D	13	I	Inverting amplifier input D
OUT D	14	O	Amplifier output D

## 6 Specifications

### 6.1 Absolute Maximum Ratings

over operating free-air temperature (unless otherwise noted) <sup>(1)</sup>

	MIN	MAX	UNIT
Supply voltage		36	V
Input voltage	(V <sub>-</sub> ) - 0.7	(V <sub>+</sub> ) + 0.7	V
Output short circuit	Continuous		
Operating temperature	-55	125	°C
Junction temperature		150	°C
Lead temperature (soldering, 10 s)		300	°C

(1) Stresses beyond those listed under *Absolute Maximum Ratings* may cause permanent damage to the device. These are stress ratings only, which do not imply functional operation of the device at these or any other conditions beyond those indicated under *Recommended Operating Conditions*. Exposure to absolute-maximum-rated conditions for extended periods may affect device reliability.

### 6.2 Handling Ratings

	MIN	MAX	UNIT
T <sub>stg</sub> Storage temperature range	-55	125	°C
V <sub>(ESD)</sub> Electrostatic discharge	Human body model (HBM), per ANSI/ESDA/JEDEC JS-001, all pins <sup>(1)</sup>		V
	Machine model (MM)		
	-2000	2000	
	-100	100	

(1) JEDEC document JEP155 states that 500-V HBM allows safe manufacturing with a standard ESD control process.

### 6.3 Recommended Operating Conditions

over operating free-air temperature range (unless otherwise noted)

	MIN	MAX	UNIT
Dual supply voltage	±5	±15	V
T <sub>J</sub> Operating junction temperature	-55	125	°C

### 6.4 Thermal Information

THERMAL METRIC <sup>(1)</sup>		OPA4277-EP	UNIT
		D (14 PINS)	
R <sub>θJA</sub>	Junction-to-ambient thermal resistance	66.3	°C/W
R <sub>θJC(top)</sub>	Junction-to-case (top) thermal resistance	19.3	
R <sub>θJB</sub>	Junction-to-board thermal resistance	26.8	
ψ <sub>JT</sub>	Junction-to-top characterization parameter	2.1	
ψ <sub>JB</sub>	Junction-to-board characterization parameter	26.2	
R <sub>θJC(bot)</sub>	Junction-to-case (bottom) thermal resistance	N/A	

(1) For more information about traditional and new thermal metrics, see the *IC Package Thermal Metrics* application report, [SPRA953](#).

## 6.5 Electrical Characteristics

At  $T_J = 25^\circ\text{C}$ , and  $R_L = 2\text{ k}\Omega$ ,  $V_S = \pm 5$  to  $\pm 15\text{ V}$  (unless otherwise noted)

PARAMETER		TEST CONDITIONS	MIN	TYP	MAX	UNIT
<b>OFFSET VOLTAGE</b>						
$V_{OS}$	Input offset voltage			$\pm 20$	$\pm 65$	$\mu\text{V}$
	Input offset voltage over temperature	$T_J = -55^\circ\text{C}$ to $125^\circ\text{C}$			$\pm 140$	
$dV_{OS}/dT$	Input offset voltage drift			$\pm 0.15$		$\mu\text{V}/^\circ\text{C}$
PSRR	Input offset voltage	vs time		0.2		$\mu\text{V}/\text{mo}$
		vs power supply, $V_S = \pm 2$ to $\pm 18\text{ V}$		$\pm 0.3$	$\pm 1$	$\mu\text{V}/\text{V}$
		$T_J = -55^\circ\text{C}$ to $125^\circ\text{C}$ ; $V_S = \pm 2$ to $\pm 18\text{ V}$				$\pm 1$
	Channel separation	dc		0.1		$\mu\text{V}/\text{V}$
<b>INPUT BIAS CURRENT</b>						
$I_B$	Input bias current			$\pm 0.5$	$\pm 2.8$	nA
		$T_J = -55^\circ\text{C}$ to $125^\circ\text{C}$				
$I_{OS}$	Input offset current			$\pm 0.5$	$\pm 2.8$	nA
		$T_J = -55^\circ\text{C}$ to $125^\circ\text{C}$				
<b>NOISE</b>						
	Input voltage noise	$f = 0.1$ to $10\text{ Hz}$		0.22		$\mu\text{V}_{pp}$
$e_n$	Input voltage noise density	$f = 10\text{ Hz}$		12		$\text{nV}/\sqrt{\text{Hz}}$
		$f = 100\text{ Hz}$		8		
		$f = 1\text{ kHz}$		8		
		$f = 10\text{ kHz}$		8		
$i_n$	Current noise density	$f = 1\text{ kHz}$		0.2		$\text{pA}/\sqrt{\text{Hz}}$
<b>INPUT VOLTAGE</b>						
$V_{CM}$	Common-mode voltage range		$(V-) + 2$		$(V+) - 2$	V
CMRR	Common-mode rejection	$V_{CM} = (V-) + 2\text{ V}$ to $(V+) - 2\text{ V}$	115	140		dB
		$T_J = -55^\circ\text{C}$ to $125^\circ\text{C}$ ; $V_{CM} = (V-) + 2\text{ V}$ to $(V+) - 2\text{ V}$	115			
<b>INPUT IMPEDANCE</b>						
	Differential			$100 \parallel 3$		$\text{M}\Omega \parallel \text{pF}$
	Common mode	$V_{CM} = (V-) + 2\text{ V}$ to $(V+) - 2\text{ V}$		$250 \parallel 3$		$\text{G}\Omega \parallel \text{pF}$
<b>OPEN-LOOP GAIN</b>						
$A_{OL}$	Open-loop voltage gain	$V_O = (V-) + 0.5\text{ V}$ to $(V+) - 1.2\text{ V}$ , $R_L = 10\text{ k}\Omega$		140		dB
		$V_O = (V-) + 1.5\text{ V}$ to $(V+) - 1.5\text{ V}$ , $R_L = 2\text{ k}\Omega$	126	134		
		$T_J = -55^\circ\text{C}$ to $125^\circ\text{C}$ ; $V_O = (V-) + 1.5\text{ V}$ to $(V+) - 1.5\text{ V}$ , $R_L = 2\text{ k}\Omega$	126			
<b>FREQUENCY RESPONSE</b>						
GBW	Gain-bandwidth product			1		MHz
SR	Slew rate			0.8		$\text{V}/\mu\text{s}$
	Setting time	0.1%, $V_S = \pm 15\text{ V}$ , $G = 1$ , 10-V step		14		$\mu\text{s}$
		0.01%, $V_S = \pm 15\text{ V}$ , $G = 1$ , 10-V step		16		
THD + N	Total harmonic distortion + noise	1 kHz, $G = 1$ , $V_O = 3.5\text{ V}_{rms}$		0.002%		

### Electrical Characteristics (continued)

At  $T_J = 25^\circ\text{C}$ , and  $R_L = 2\text{ k}\Omega$ ,  $V_S = \pm 5$  to  $\pm 15\text{ V}$  (unless otherwise noted)

PARAMETER		TEST CONDITIONS	MIN	TYP	MAX	UNIT
<b>OUTPUT</b>						
$V_O$	Voltage output	$T_J = -55^\circ\text{C}$ to $125^\circ\text{C}$ ; $R_L = 10\text{ k}\Omega$	$(V_-) + 0.5$		$(V_+) - 1.2$	V
		$T_J = -55^\circ\text{C}$ to $125^\circ\text{C}$ ; $R_L = 2\text{ k}\Omega$	$(V_-) + 1.5$		$(V_+) - 1.5$	
$I_{SC}$	Short-circuit current			$\pm 35$		mA
$C_{LOAD}$	Capacitive load drive			See <a href="#">Typical Characteristics</a>		
<b>POWER SUPPLY</b>						
$V_S$	Specified voltage		$\pm 5$		$\pm 15$	V
	Operating voltage		$\pm 2$		$\pm 18$	V
$I_Q$	Quiescent current (per amplifier)	$I_O = 0$		$\pm 790$	$\pm 825$	$\mu\text{A}$
		$T_J = -55^\circ\text{C}$ to $125^\circ\text{C}$ ; $I_O = 0$			$\pm 900$	

### 6.6 Typical Characteristics

At  $T_J = 25^\circ\text{C}$ ,  $V_S = \pm 15\text{ V}$ , and  $R_L = 2\text{ k}\Omega$ , unless otherwise noted.

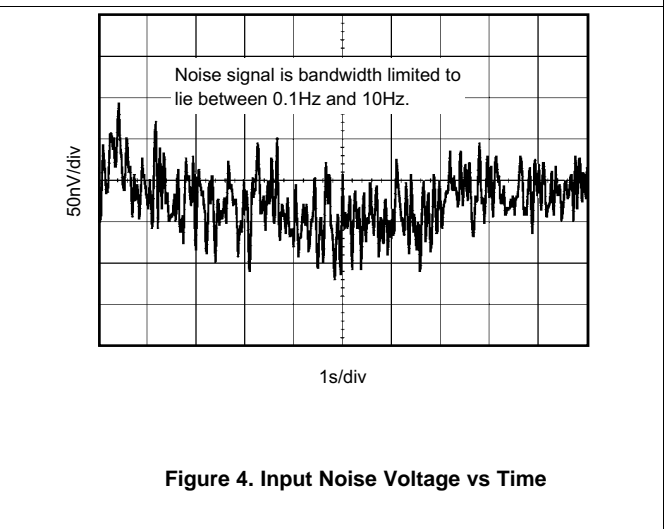
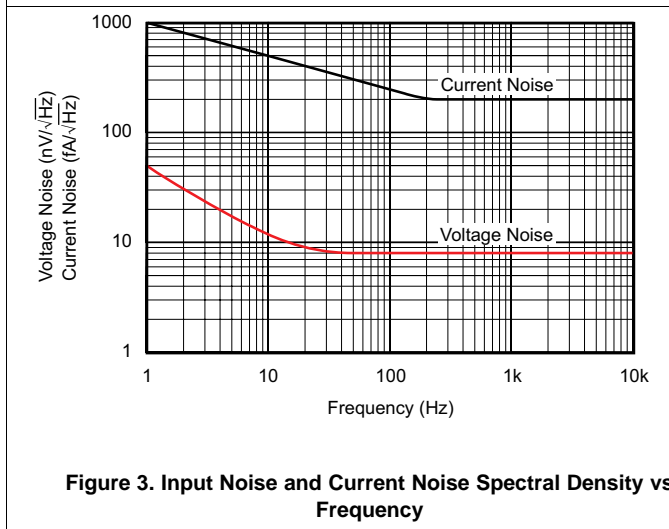
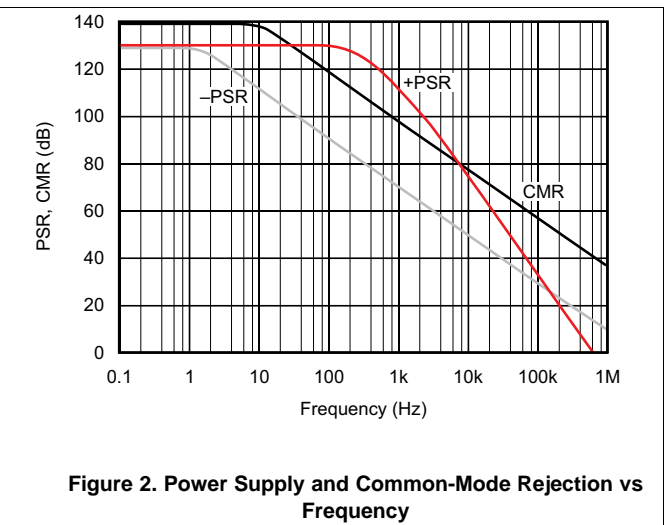
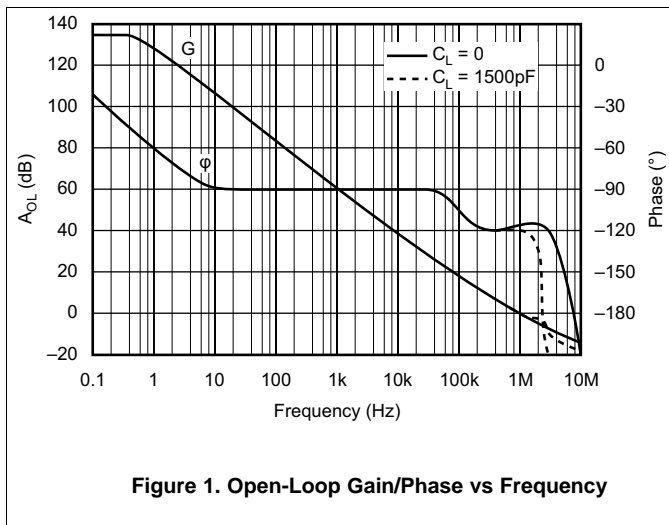

Typical Characteristics (continued)

At  $T_J = 25^\circ\text{C}$ ,  $V_S = \pm 15\text{ V}$ , and  $R_L = 2\text{ k}\Omega$ , unless otherwise noted.

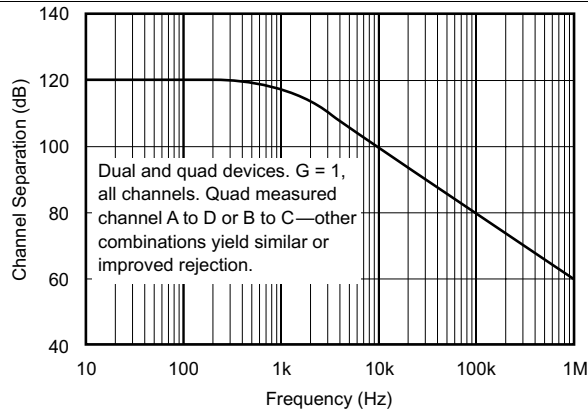
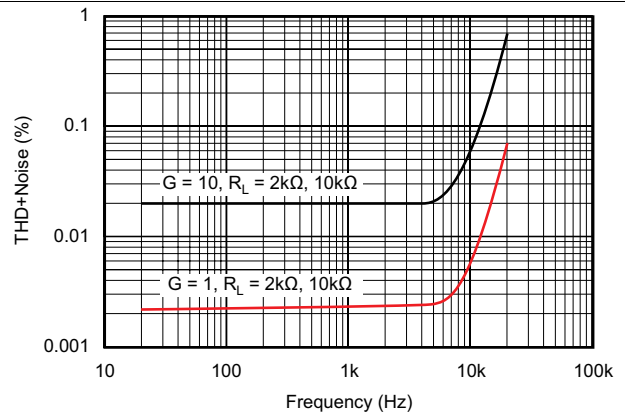

Figure 5. Channel Separation vs Frequency



$V_{OUT} = 3.5\text{ Vrms}$

Figure 6. Total Harmonic Distortion + Noise vs Frequency

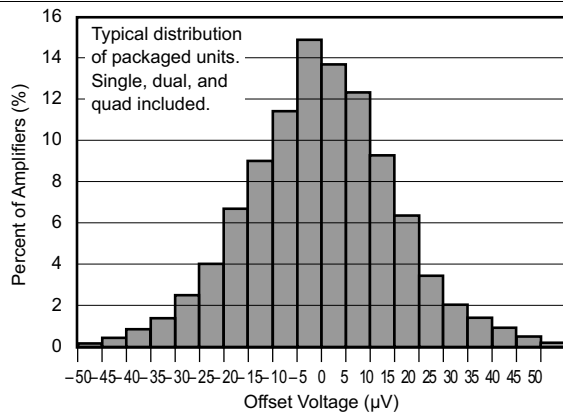

Figure 7. Offset Voltage Production Distribution

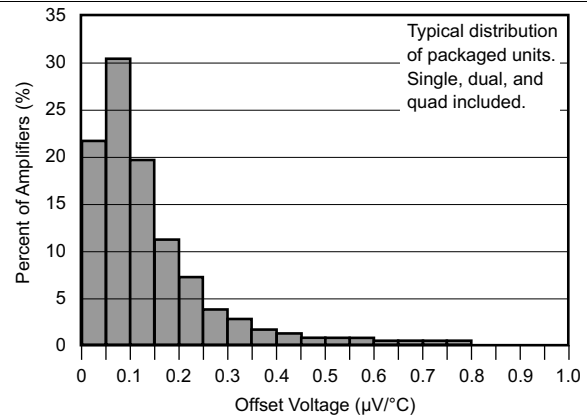

Figure 8. Offset Voltage Drift Production Distribution

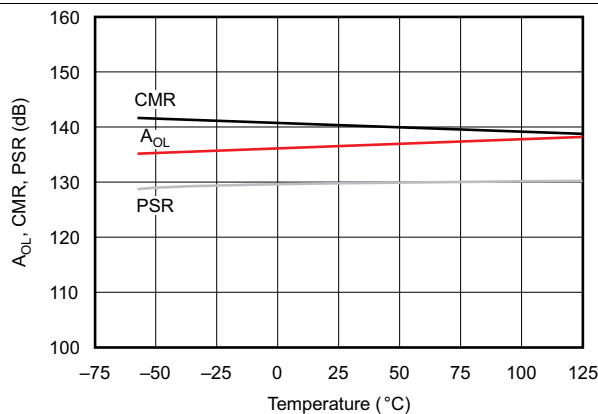

Figure 9.  $A_{OL}$ , CMR, PSR vs Temperature

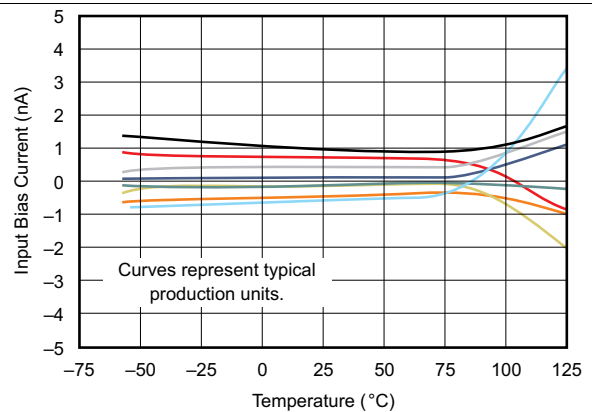

Figure 10. Input Bias Current vs Temperature

Typical Characteristics (continued)

At  $T_J = 25^\circ\text{C}$ ,  $V_S = \pm 15\text{ V}$ , and  $R_L = 2\text{ k}\Omega$ , unless otherwise noted.

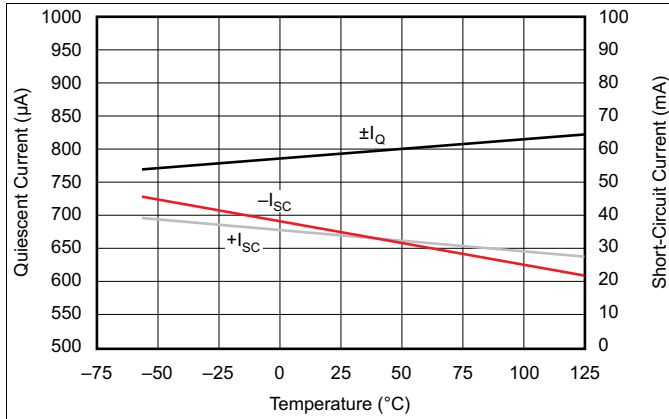

Figure 11. Quiescent Current and Short-Circuit Current vs Temperature

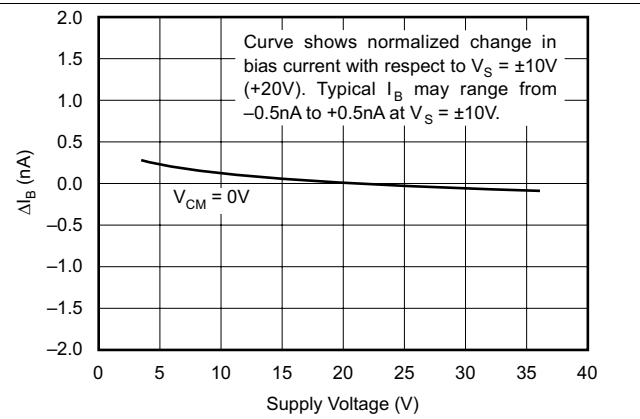

Figure 12. Change in Input Bias Current vs Power Supply Voltage

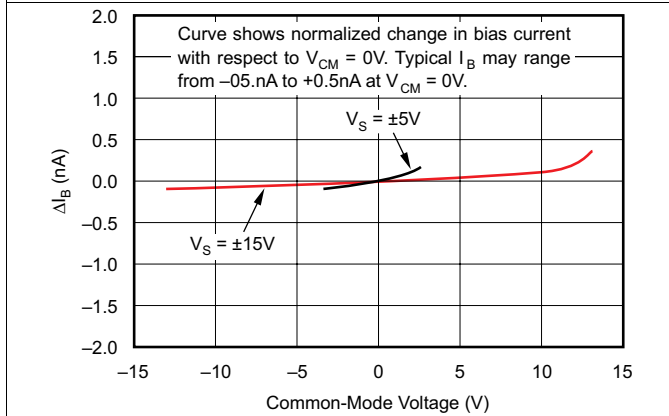

Figure 13. Change in Input Bias Current vs Common-Mode Voltage

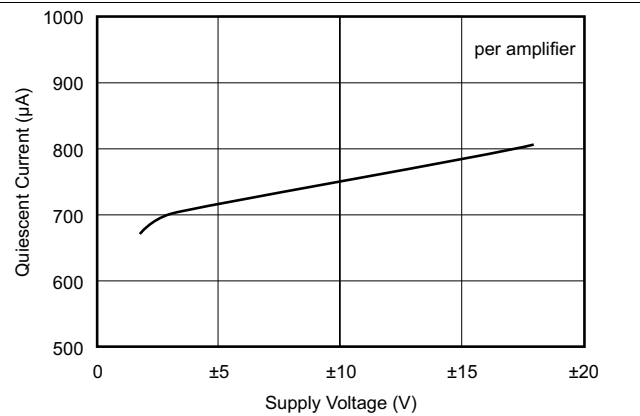

Figure 14. Quiescent Current vs Supply Voltage

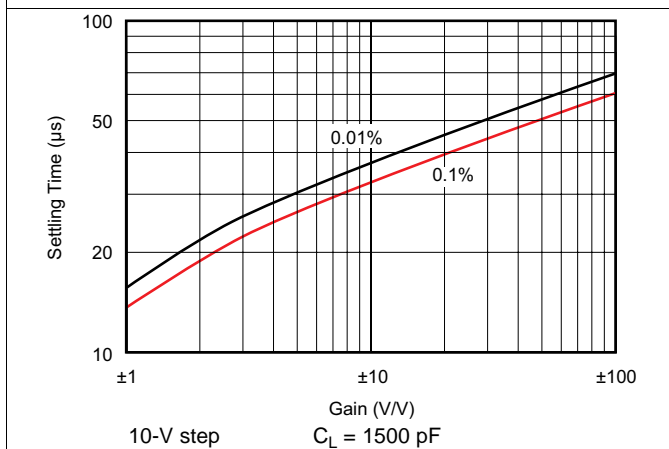

Figure 15. Settling Time vs Closed-Loop Gain

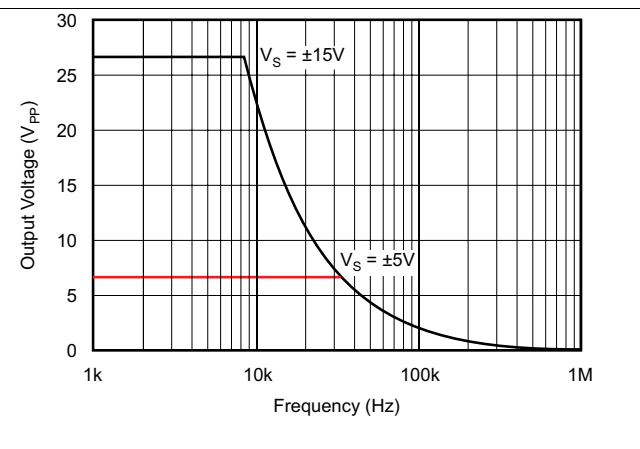

Figure 16. Maximum Output Voltage vs Frequency

Typical Characteristics (continued)

At  $T_J = 25^\circ\text{C}$ ,  $V_S = \pm 15\text{ V}$ , and  $R_L = 2\text{ k}\Omega$ , unless otherwise noted.

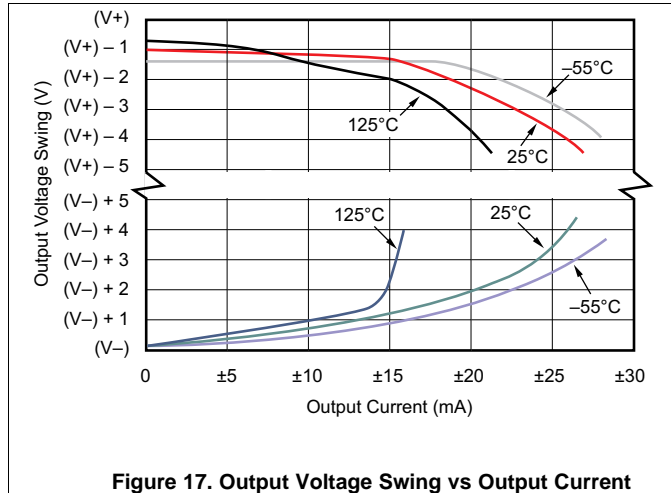

Figure 17. Output Voltage Swing vs Output Current

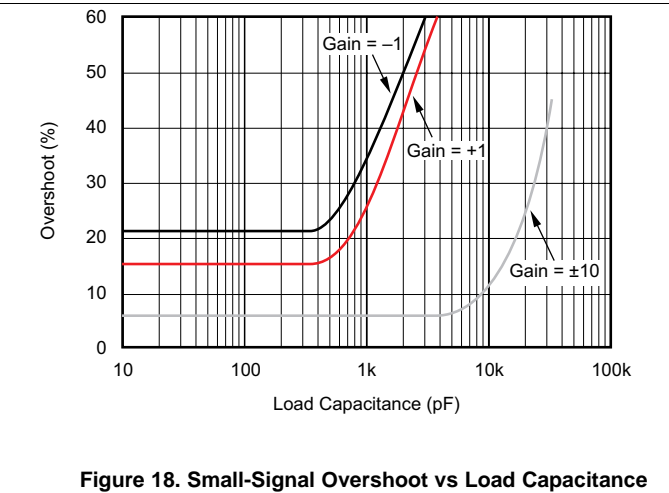

Figure 18. Small-Signal Overshoot vs Load Capacitance

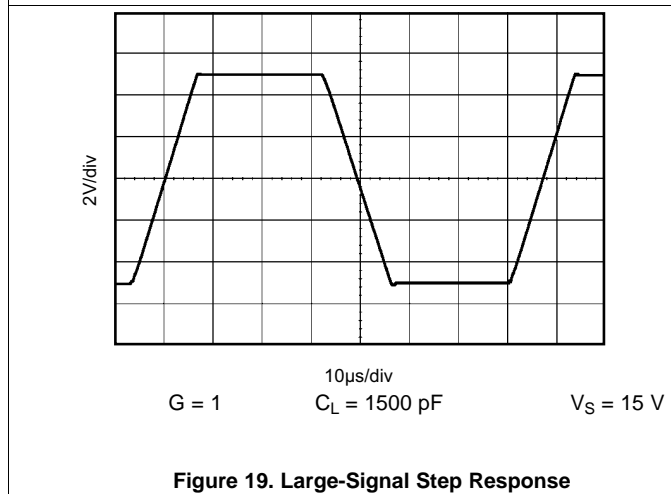

Figure 19. Large-Signal Step Response

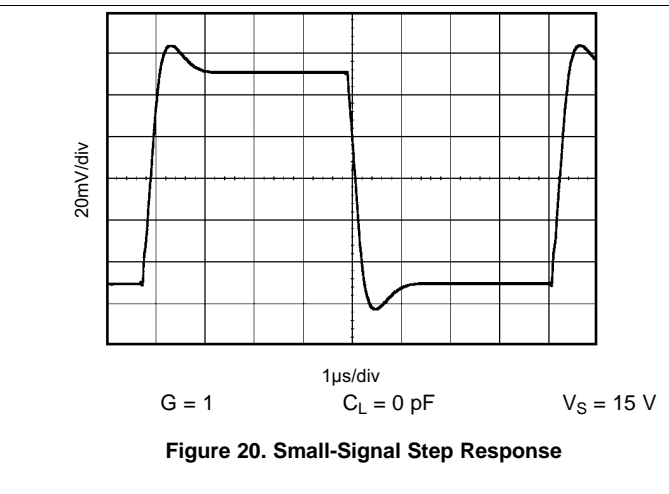

Figure 20. Small-Signal Step Response

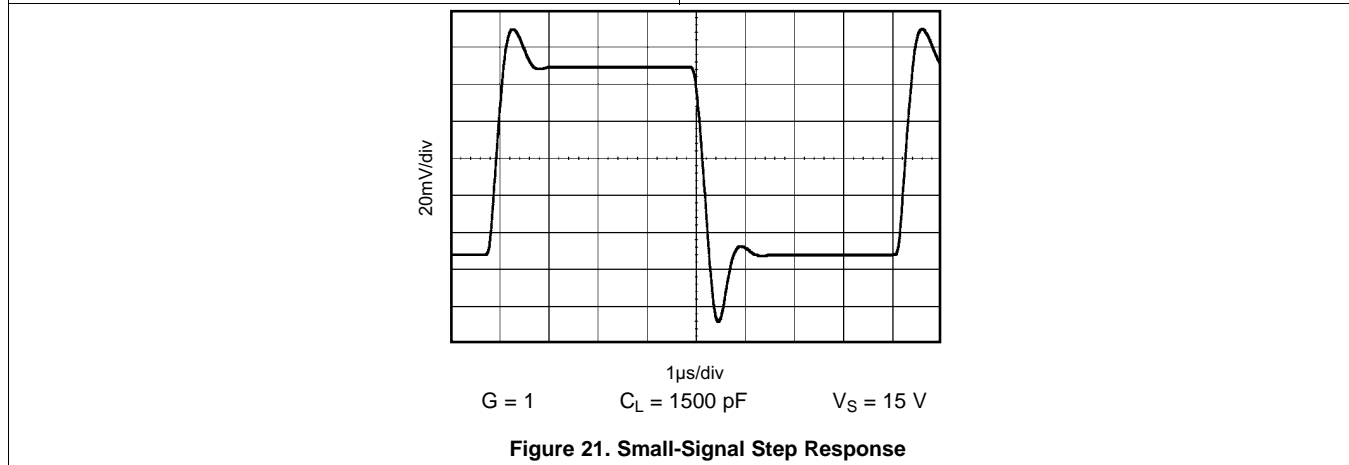

Figure 21. Small-Signal Step Response

## 7 Detailed Description

### 7.1 Overview

The OPA4277-EP precision operational amplifier replaces the industry standard OP-177. It offers improved noise, wider output voltage swing, and is twice as fast with half the quiescent current. Features include ultra-low offset voltage and drift, low bias current, high common-mode rejection, and high power supply rejection.

### 7.2 Functional Block Diagram

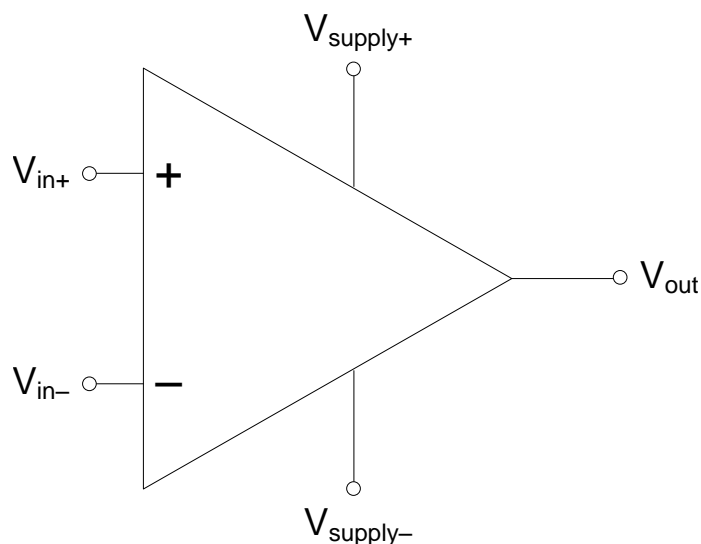

### 7.3 Feature Description

The OPA4277-EP operates from  $\pm 2$ - to  $\pm 18$ -V supplies with excellent performance. Unlike most operational amplifiers which are specified at only one supply voltage, the OPA4277-EP precision operational amplifier is specified for real-world applications; a single limit applies over the  $\pm 5$ - to  $\pm 15$ -V supply range. High performance is maintained as the amplifier swings to the specified limits. Because the initial offset voltage ( $\pm 50 \mu\text{V}$  max) is so low, user adjustment is usually not required.

## 8 Application and Implementation

### NOTE

Information in the following applications sections is not part of the TI component specification, and TI does not warrant its accuracy or completeness. TI's customers are responsible for determining suitability of components for their purposes. Customers should validate and test their design implementation to confirm system functionality.

### 8.1 Application Information

The OPA4277 is unity-gain stable and free from unexpected output phase reversal, making it easy to use in a wide range of applications. Applications with noisy or high-impedance power supplies may require decoupling capacitors close to the device pins. In most cases, 0.1- $\mu$ F capacitors are adequate.

### 8.2 Typical Application

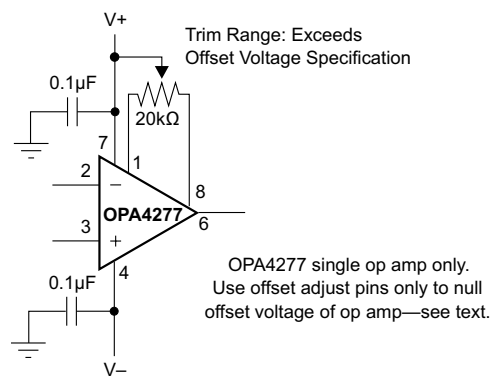

Figure 22. OPA4277 Offset Voltage Trim Circuit

#### 8.2.1 Design Requirements

For the thermocouple low-offset, low-drift loop measurement with diode cold junction compensation (see Figure 25), Table 1 lists the design parameters needed with gain = 50.

$$G = 1 + \frac{2R_F}{R} = 50 \quad (1)$$

Table 1. Design Parameters

DESIGN PARAMETER	EXAMPLE VALUE
$R_F$	10 k $\Omega$
$R$	412 $\Omega$

#### 8.2.2 Detailed Design Procedure

##### 8.2.2.1 Offset Voltage Adjustment

The OPA27 is laser-trimmed for very-low offset voltage and drift so most circuits do not require external adjustment. However, offset voltage trim connections are provided on pins 1 and 8. The user can adjust offset voltage by connecting a potentiometer as shown in Figure 22. Only use this adjustment to null the offset of the operational amplifier. This adjustment should not be used to compensate for offsets created elsewhere in a system because this can introduce additional temperature drift.

### 8.2.2.2 Input Protection

The inputs of the OPA4277 are protected with 1-kΩ series input resistors and diode clamps. The inputs can withstand ±30-V differential inputs without damage. The protection diodes conduct current when the inputs are overdriven. This may disturb the slewing behavior of unity-gain follower applications, but will not damage the operational amplifier.

### 8.2.2.3 Input Bias Current Cancellation

The input stage base current of the OPA4277 is internally compensated with an equal and opposite cancellation circuit. The resulting input bias current is the difference between the input stage base current and the cancellation current. This residual input bias current can be positive or negative.

When the bias current is canceled in this manner, the input bias current and input offset current are approximately the same magnitude. As a result, it is not necessary to use a bias current cancellation resistor, as is often done with other operational amplifiers (see [Figure 23](#)). A resistor added to cancel input bias current errors may actually increase offset voltage and noise.

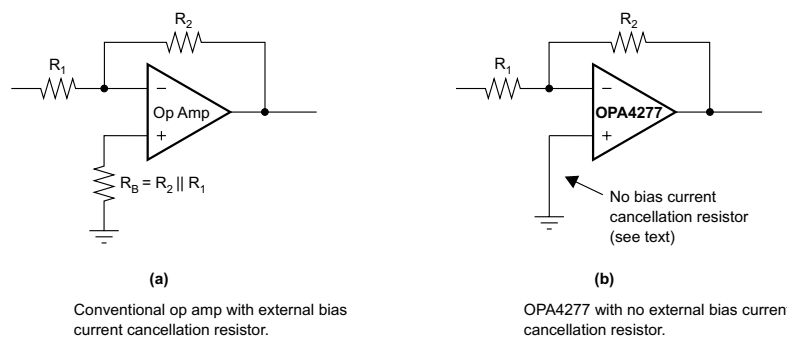

**Figure 23. Input Bias Current Cancellation**

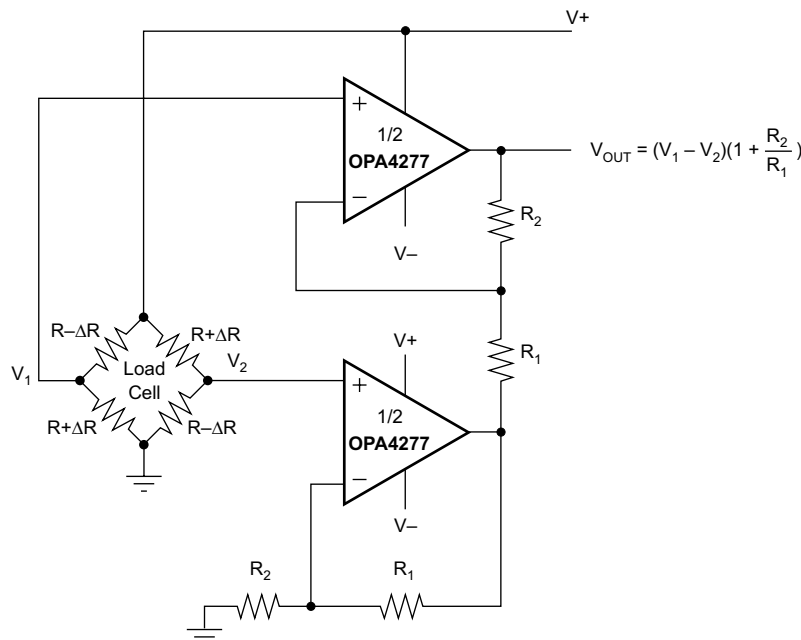

For integrated solution see: INA126, INA2126 (dual)  
 INA125 (on-board reference)  
 INA122 (single-supply)

**Figure 24. Load Cell Amplifier**

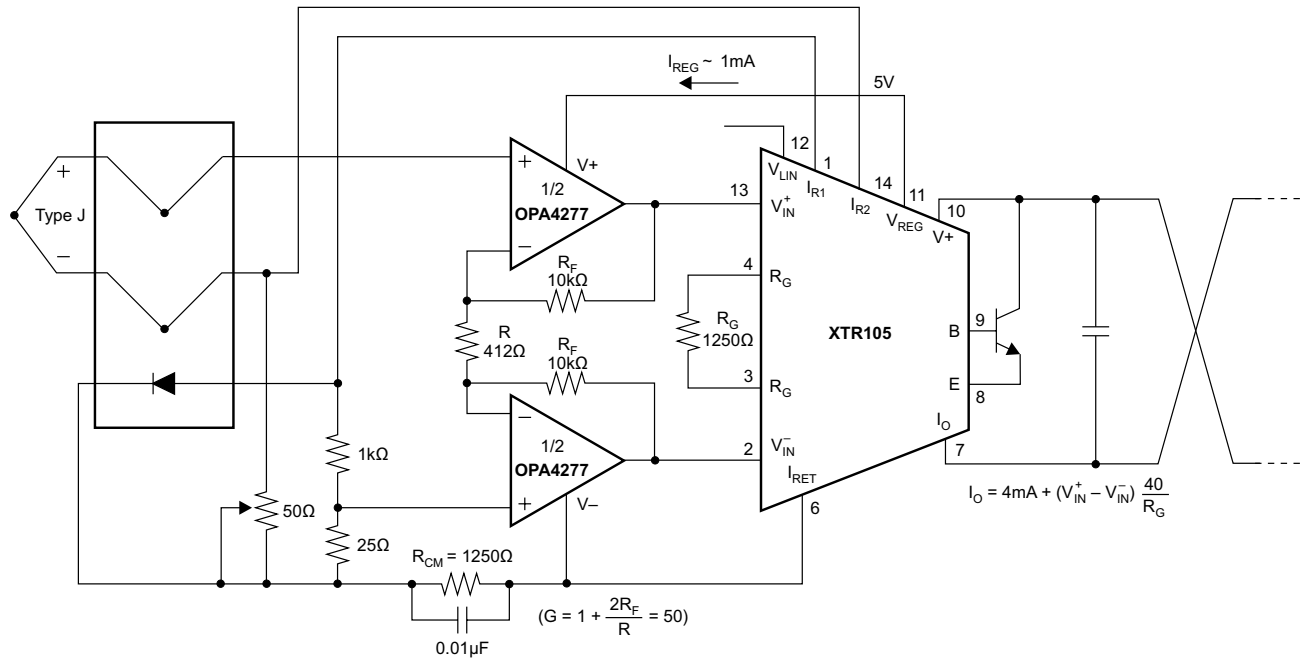

Figure 25. Thermocouple Low Offset, Low Drift Loop Measurement With Diode Cold Junction Compensation

8.2.3 Application Curve

At  $T_J = 25^\circ\text{C}$ ,  $V_S = \pm 15\text{ V}$ , and  $R_L = 2\text{ k}\Omega$ , unless otherwise noted.

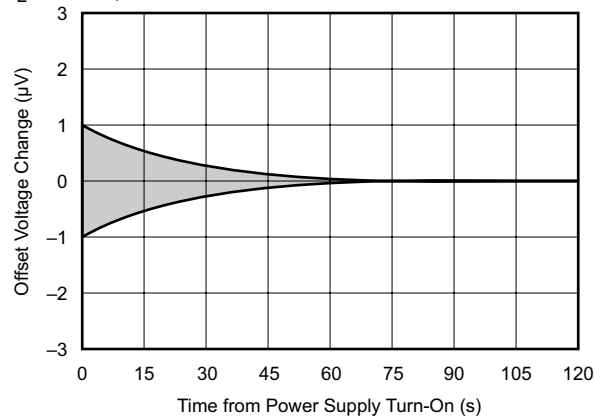

Figure 26. Warm-Up Offset Voltage Drift

## 9 Power Supply Recommendations

OPA4277 operates from  $\pm 2$ - to  $\pm 18$ -V supplies with excellent performance. Unlike most operational amplifiers which are specified at only one supply voltage, the OPA4277 is specified for real-world applications; a single limit applies over the  $\pm 5$ - to  $\pm 15$ -V supply range. This allows a customer operating at  $V_S = \pm 10$  V to have the same assured performance as a customer using  $\pm 15$ -V supplies. In addition, key parameters are assured over the specified temperature range,  $-55^\circ\text{C}$  to  $125^\circ\text{C}$ . Most behavior remains unchanged through the full operating voltage range ( $\pm 2$  to  $\pm 18$  V). Parameters which vary significantly with operating voltage or temperature are shown in the typical performance curves.

## 10 Layout

### 10.1 Layout Guidelines

The leadframe die pad should be soldered to a thermal pad on the PCB. Mechanical drawings located in [Mechanical, Packaging, and Orderable Information](#) show the physical dimensions for the package and pad.

Soldering the exposed pad significantly improves board-level reliability during temperature cycling, key push, package shear, and similar board-level tests. Even with applications that have low-power dissipation, the exposed pad must be soldered to the PCB to provide structural integrity and long-term reliability.

The OPA4277 has very-low offset voltage and drift. To achieve highest performance, optimize circuit layout and mechanical conditions. Offset voltage and drift can be degraded by small thermoelectric potentials at the operational amplifier inputs. Connections of dissimilar metals generate thermal potential, which can degrade the ultimate performance of the OPA4277. Cancel these thermal potentials by assuring that they are equal in both input terminals.

- Keep the thermal mass of the connections made to the two input terminals similar.
- Locate heat sources as far as possible from the critical input circuitry.
- Shield operational amplifier and input circuitry from air currents such as cooling fans.

## 10.2 Layout Example

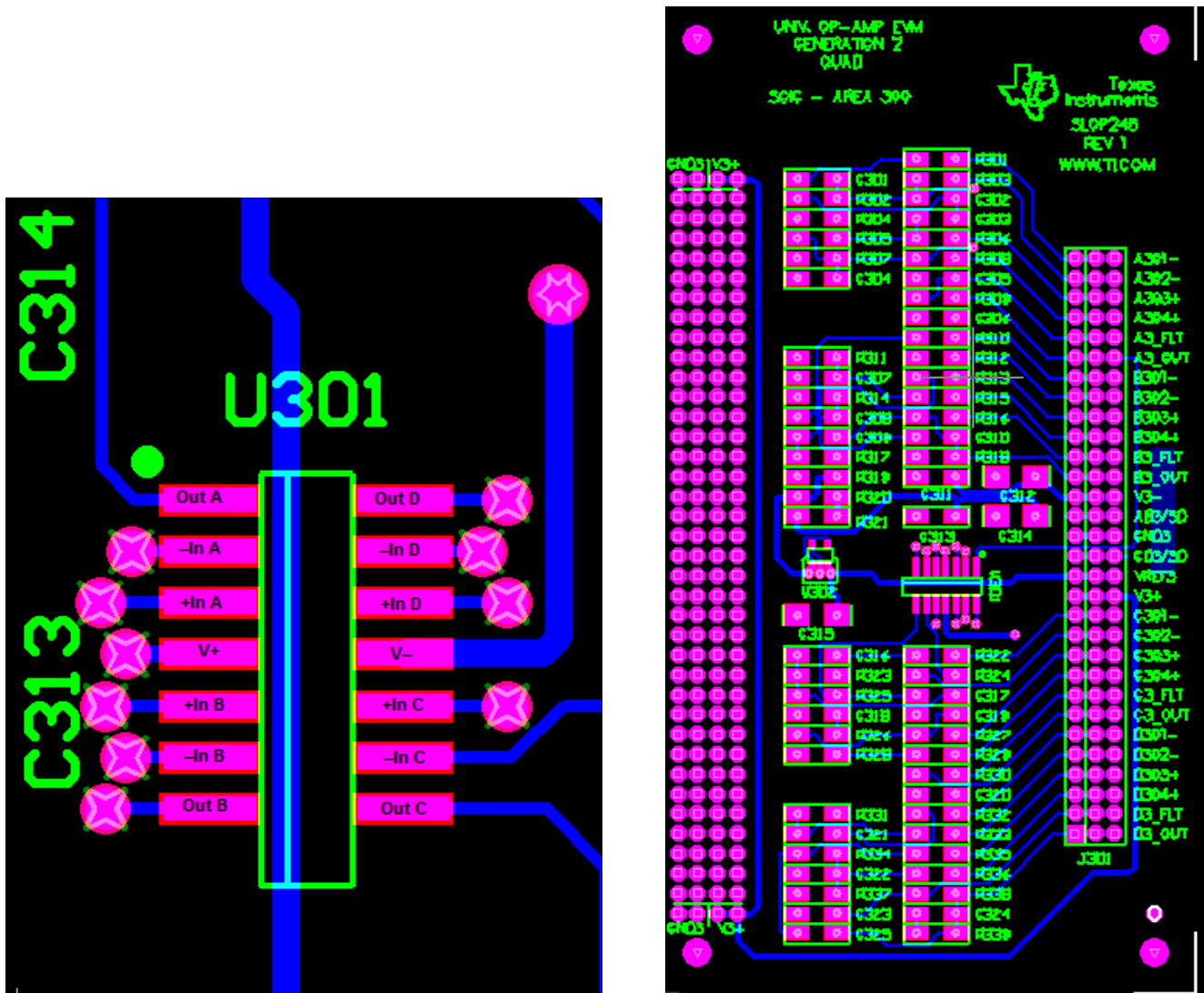

Figure 27. Board Layout Example

## 11 Device and Documentation Support

### 11.1 Trademarks

All trademarks are the property of their respective owners.

### 11.2 Electrostatic Discharge Caution



These devices have limited built-in ESD protection. The leads should be shorted together or the device placed in conductive foam during storage or handling to prevent electrostatic damage to the MOS gates.

### 11.3 Glossary

[SLYZ022](#) — *TI Glossary*.

This glossary lists and explains terms, acronyms, and definitions.

## 12 Mechanical, Packaging, and Orderable Information

The following pages include mechanical, packaging, and orderable information. This information is the most current data available for the designated devices. This data is subject to change without notice and revision of this document. For browser-based versions of this data sheet, refer to the left-hand navigation.

## PACKAGING INFORMATION

Orderable Device	Status (1)	Package Type	Package Drawing	Pins	Package Qty	Eco Plan (2)	Lead/Ball Finish (6)	MSL Peak Temp (3)	Op Temp (°C)	Device Marking (4/5)	Samples
OPA4277MDREP	PREVIEW	SOIC	D	14	2500	Green (RoHS & no Sb/Br)	CU NIPDAU-DCC	Level-3-260C-168 HR	-55 to 125	OPA4277EP	
OPA4277MDTEP	ACTIVE	SOIC	D	14	250	Green (RoHS & no Sb/Br)	CU NIPDAU-DCC	Level-3-260C-168 HR	-55 to 125	OPA4277EP	Samples
V62/14625-01XE	ACTIVE	SOIC	D	14	250	Green (RoHS & no Sb/Br)	CU NIPDAU-DCC	Level-3-260C-168 HR	-55 to 125	OPA4277EP	Samples

(1) The marketing status values are defined as follows:

**ACTIVE:** Product device recommended for new designs.

**LIFEBUY:** TI has announced that the device will be discontinued, and a lifetime-buy period is in effect.

**NRND:** Not recommended for new designs. Device is in production to support existing customers, but TI does not recommend using this part in a new design.

**PREVIEW:** Device has been announced but is not in production. Samples may or may not be available.

**OBsolete:** TI has discontinued the production of the device.

(2) Eco Plan - The planned eco-friendly classification: Pb-Free (RoHS), Pb-Free (RoHS Exempt), or Green (RoHS & no Sb/Br) - please check <http://www.ti.com/productcontent> for the latest availability information and additional product content details.

**TBD:** The Pb-Free/Green conversion plan has not been defined.

**Pb-Free (RoHS):** TI's terms "Lead-Free" or "Pb-Free" mean semiconductor products that are compatible with the current RoHS requirements for all 6 substances, including the requirement that lead not exceed 0.1% by weight in homogeneous materials. Where designed to be soldered at high temperatures, TI Pb-Free products are suitable for use in specified lead-free processes.

**Pb-Free (RoHS Exempt):** This component has a RoHS exemption for either 1) lead-based flip-chip solder bumps used between the die and package, or 2) lead-based die adhesive used between the die and leadframe. The component is otherwise considered Pb-Free (RoHS compatible) as defined above.

**Green (RoHS & no Sb/Br):** TI defines "Green" to mean Pb-Free (RoHS compatible), and free of Bromine (Br) and Antimony (Sb) based flame retardants (Br or Sb do not exceed 0.1% by weight in homogeneous material)

(3) MSL, Peak Temp. - The Moisture Sensitivity Level rating according to the JEDEC industry standard classifications, and peak solder temperature.

(4) There may be additional marking, which relates to the logo, the lot trace code information, or the environmental category on the device.

(5) Multiple Device Markings will be inside parentheses. Only one Device Marking contained in parentheses and separated by a "~" will appear on a device. If a line is indented then it is a continuation of the previous line and the two combined represent the entire Device Marking for that device.

(6) Lead/Ball Finish - Orderable Devices may have multiple material finish options. Finish options are separated by a vertical ruled line. Lead/Ball Finish values may wrap to two lines if the finish value exceeds the maximum column width.

**Important Information and Disclaimer:** The information provided on this page represents TI's knowledge and belief as of the date that it is provided. TI bases its knowledge and belief on information provided by third parties, and makes no representation or warranty as to the accuracy of such information. Efforts are underway to better integrate information from third parties. TI has taken and

continues to take reasonable steps to provide representative and accurate information but may not have conducted destructive testing or chemical analysis on incoming materials and chemicals. TI and TI suppliers consider certain information to be proprietary, and thus CAS numbers and other limited information may not be available for release.

In no event shall TI's liability arising out of such information exceed the total purchase price of the TI part(s) at issue in this document sold by TI to Customer on an annual basis.

**OTHER QUALIFIED VERSIONS OF OPA4277-EP :**

- Catalog: [OPA4277](#)

**NOTE: Qualified Version Definitions:**

- Catalog - TI's standard catalog product

## TAPE AND REEL INFORMATION

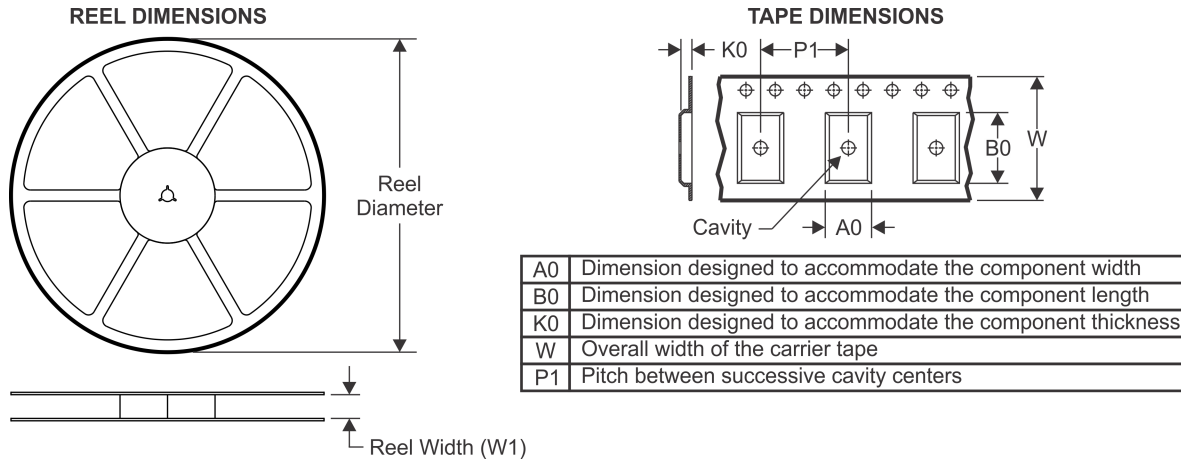

### QUADRANT ASSIGNMENTS FOR PIN 1 ORIENTATION IN TAPE



\*All dimensions are nominal

Device	Package Type	Package Drawing	Pins	SPQ	Reel Diameter (mm)	Reel Width W1 (mm)	A0 (mm)	B0 (mm)	K0 (mm)	P1 (mm)	W (mm)	Pin1 Quadrant
OPA4277MDTEP	SOIC	D	14	250	180.0	16.4	6.5	9.0	2.1	8.0	16.0	Q1

TAPE AND REEL BOX DIMENSIONS



\*All dimensions are nominal

Device	Package Type	Package Drawing	Pins	SPQ	Length (mm)	Width (mm)	Height (mm)
OPA4277MDTEP	SOIC	D	14	250	210.0	185.0	35.0



D (R-PDSO-G14)

PLASTIC SMALL OUTLINE



4211283-3/E 08/12

- NOTES:
- All linear dimensions are in millimeters.
  - This drawing is subject to change without notice.
  - Publication IPC-7351 is recommended for alternate designs.
  - Laser cutting apertures with trapezoidal walls and also rounding corners will offer better paste release. Customers should contact their board assembly site for stencil design recommendations. Refer to IPC-7525 for other stencil recommendations.
  - Customers should contact their board fabrication site for solder mask tolerances between and around signal pads.

## IMPORTANT NOTICE AND DISCLAIMER

TI PROVIDES TECHNICAL AND RELIABILITY DATA (INCLUDING DATASHEETS), DESIGN RESOURCES (INCLUDING REFERENCE DESIGNS), APPLICATION OR OTHER DESIGN ADVICE, WEB TOOLS, SAFETY INFORMATION, AND OTHER RESOURCES "AS IS" AND WITH ALL FAULTS, AND DISCLAIMS ALL WARRANTIES, EXPRESS AND IMPLIED, INCLUDING WITHOUT LIMITATION ANY IMPLIED WARRANTIES OF MERCHANTABILITY, FITNESS FOR A PARTICULAR PURPOSE OR NON-INFRINGEMENT OF THIRD PARTY INTELLECTUAL PROPERTY RIGHTS.

These resources are intended for skilled developers designing with TI products. You are solely responsible for (1) selecting the appropriate TI products for your application, (2) designing, validating and testing your application, and (3) ensuring your application meets applicable standards, and any other safety, security, or other requirements. These resources are subject to change without notice. TI grants you permission to use these resources only for development of an application that uses the TI products described in the resource. Other reproduction and display of these resources is prohibited. No license is granted to any other TI intellectual property right or to any third party intellectual property right. TI disclaims responsibility for, and you will fully indemnify TI and its representatives against, any claims, damages, costs, losses, and liabilities arising out of your use of these resources.

TI's products are provided subject to TI's Terms of Sale ([www.ti.com/legal/termsofsale.html](http://www.ti.com/legal/termsofsale.html)) or other applicable terms available either on [ti.com](http://ti.com) or provided in conjunction with such TI products. TI's provision of these resources does not expand or otherwise alter TI's applicable warranties or warranty disclaimers for TI products.

Mailing Address: Texas Instruments, Post Office Box 655303, Dallas, Texas 75265  
Copyright © 2019, Texas Instruments Incorporated

## Looking for pricing, stock, or lifecycle information?

Click below to explore more details on WIN SOURCE:

 [View OPA4277MDTEP](#) on WIN SOURCE

 [Texas Instruments](#) Information

## Optimize Your Supply Chain with WIN SOURCE Solutions

-  Global Sourcing Solution
-  Obsolete Management
-  Cost Control Management
-  Shortage Management
-  Alternative Solution
-  Excess Inventory Management