



THE DATASHEET OF NUC130RD2CN





ARM Cortex™-M0

32-BIT MICROCONTROLLER

**NuMicro™ NUC100 Series
NUC130/NUC140
Technical Reference Manual**

The information described in this document is the exclusive intellectual property of Nuvoton Technology Corporation and shall not be reproduced without permission from Nuvoton.

Nuvoton is providing this document only for reference purposes of NuMicro microcontroller based system design. Nuvoton assumes no responsibility for errors or omissions.

All data and specifications are subject to change without notice.

For additional information or questions, please contact: Nuvoton Technology Corporation.



Table of Contents

LIST OF FIGURES.....	7
LIST OF TABLES.....	11
1 GENERAL DESCRIPTION.....	12
2 FEATURES.....	13
2.1 NuMicro™ NUC130 Features – Automotive Line.....	13
2.2 NuMicro™ NUC140 Features – Connectivity Line.....	17
3 PARTS INFORMATION LIST AND PIN CONFIGURATION.....	21
3.1 NuMicro™ NUC130 Products Selection Guide.....	21
3.1.1 NuMicro™ NUC130 Automotive Line Selection Guide.....	21
3.2 NuMicro™ NUC140 Products Selection Guide.....	22
3.2.1 NuMicro™ NUC140 Connectivity Line Selection Guide.....	22
3.3 Pin Configuration.....	23
3.3.1 NuMicro™ NUC130/NUC140 Pin Diagram.....	23
3.4 Pin Description.....	29
3.4.1 NuMicro™ NUC130/NUC140 Pin Description.....	29
4 BLOCK DIAGRAM.....	45
4.1 NuMicro™NUC130/NUC140 Block Diagram.....	45
4.1.1 NuMicro™ NUC130 Block Diagram.....	45
4.1.2 NuMicro™ NUC140 Block Diagram.....	46
5 FUNCTIONAL DESCRIPTION.....	47
5.1 ARM® Cortex™-M0 Core.....	47
5.2 System Manager.....	49
5.2.1 Overview.....	49
5.2.2 System Reset.....	49
5.2.3 System Power Distribution.....	50
5.2.4 System Memory Map.....	52
5.2.5 System Manager Control Registers.....	54
5.2.6 System Timer (SysTick).....	89
5.2.7 Nested Vectored Interrupt Controller (NVIC).....	94
5.2.8 System Control Register.....	119
5.3 Clock Controller.....	127
5.3.1 Overview.....	127
5.3.2 Clock Generator.....	129
5.3.3 System Clock and SysTick Clock.....	130
5.3.4 Peripherals Clock.....	131
5.3.5 Power-down Mode Clock.....	131
5.3.6 Frequency Divider Output.....	132
5.3.7 Register Map.....	133
5.3.8 Register Description.....	134
5.4 USB Device Controller (USB).....	152



5.4.1	Overview	152
5.4.2	Features	152
5.4.3	Block Diagram	153
5.4.4	Functional Description	154
5.4.5	Register and Memory Map	158
5.4.6	Register Description	160
5.5	General Purpose I/O (GPIO)	177
5.5.1	Overview	177
5.5.2	Features	177
5.5.3	Functional Description	178
5.5.4	Register Map	181
5.5.5	Register Description	186
5.6	I ² C Serial Interface Controller (Master/Slave) (I ² C)	200
5.6.1	Overview	200
5.6.2	Features	201
5.6.3	Functional Description	202
5.6.4	Protocol Registers	205
5.6.5	Register Map	209
5.6.6	Register Description	210
5.6.7	Operation Modes	218
5.7	PWM Generator and Capture Timer (PWM)	224
5.7.1	Overview	224
5.7.2	Features	225
5.7.3	Block Diagram	226
5.7.4	Functional Description	230
5.7.5	Register Map	238
5.7.6	Register Description	241
5.8	Real Time Clock (RTC)	263
5.8.1	Overview	263
5.8.2	Features	263
5.8.3	Block Diagram	264
5.8.4	Functional Description	265
5.8.5	Register Map	267
5.8.6	Register Description	268
5.9	Serial Peripheral Interface (SPI)	282
5.9.1	Overview	282
5.9.2	Features	282
5.9.3	Block Diagram	283
5.9.4	Functional Description	284
5.9.5	Timing Diagram	291
5.9.6	Programming Examples	293
5.9.7	Register Map	296
5.9.8	Register Description	297
5.10	Timer Controller (TMR)	309
5.10.1	Overview	309



5.10.2	Features	309
5.10.3	Block Diagram	310
5.10.4	Functional Description	311
5.10.5	Register Map	314
5.10.6	Register Description	316
5.11	Watchdog Timer (WDT)	325
5.11.1	Overview	325
5.11.2	Features	327
5.11.3	Block Diagram	327
5.11.4	Register Map	328
5.11.5	Register Description	329
5.12	UART Interface Controller (UART)	331
5.12.1	Overview	331
5.12.2	Features	333
5.12.3	Block Diagram	334
5.12.4	IrDA Mode	337
5.12.5	LIN (Local Interconnection Network) Mode	339
5.12.6	RS-485 Function Mode	340
5.12.7	Register Map	342
5.12.8	Register Description	344
5.13	Controller Area Network (CAN)	370
5.13.1	Overview	370
5.13.2	Features	370
5.13.3	Block Diagram	371
5.13.4	Functional Description	372
5.13.5	Test Mode	373
5.13.6	CAN Communications	375
5.13.7	Register Description	395
5.13.8	Register Map	395
5.13.9	CAN Interface Reset State	396
5.14	PS/2 Device Controller (PS2D)	435
5.14.1	Overview	435
5.14.2	Features	435
5.14.3	Block Diagram	436
5.14.4	Functional Description	437
5.14.5	Register Map	442
5.14.6	Register Description	443
5.15	I ² S Controller (I ² S)	450
5.15.1	Overview	450
5.15.2	Features	450
5.15.3	Block Diagram	451
5.15.4	Functional Description	452
5.15.5	Register Map	454
5.15.6	Register Description	455
5.16	Analog-to-Digital Converter (ADC)	467



5.16.1	Overview	467
5.16.2	Features	467
5.16.3	Block Diagram	468
5.16.4	Functional Description	469
5.16.5	Register Map	475
5.16.6	Register Description	476
5.17	Analog Comparator (CMP)	490
5.17.1	Overview	490
5.17.2	Features	490
5.17.3	Block Diagram	490
5.17.4	Functional Description	492
5.17.5	Register Map	493
5.17.6	Register Description	494
5.18	PDMA Controller (PDMA)	497
5.18.1	Overview	497
5.18.2	Features	497
5.18.3	Block Diagram	498
5.18.4	Functional Description	499
5.18.5	Register Map	500
5.18.6	Register Description	501
5.19	External Bus Interface (EBI)	522
5.19.1	Overview	522
5.19.2	Features	522
5.19.3	Block Diagram	523
5.19.4	Functional Description	523
5.19.5	Register Map	529
5.19.6	Register Description	529
6	FLASH MEMORY CONTROLLER (FMC)	532
6.1	Overview	532
6.2	Features	532
6.3	Block Diagram	533
6.4	Flash Memory Organization	534
6.5	Boot Selection	536
6.6	Data Flash	536
6.7	User Configuration	537
6.8	In System Program (ISP)	540
6.8.1	ISP Procedure	540
6.9	Flash Control Register Map	543
6.10	Flash Control Register Description	544
7	ELECTRICAL CHARACTERISTICS	552
7.1	Absolute Maximum Ratings	552
7.2	DC Electrical Characteristics	553



	7.2.1	NuMicro™ NUC130/NUC140 DC Electrical Characteristics.....	553
7.3		AC Electrical Characteristics	558
	7.3.1	External 4 ~ 24 MHz High Speed Oscillator.....	558
	7.3.2	External 4 ~ 24 MHz High Speed Crystal.....	558
	7.3.3	External 32.768 kHz Low Speed Crystal.....	559
	7.3.4	Internal 22.1184 MHz High Speed Oscillator	559
	7.3.5	Internal 10 kHz Low Speed Oscillator	559
7.4		Analog Characteristics	560
	7.4.1	12-bit SARADC Specifications	560
	7.4.2	LDO and Power Management Specifications	561
	7.4.3	Low Voltage Reset Specifications.....	562
	7.4.4	Brown-out Detector Specifications	562
	7.4.5	Power-on Reset (5V) Specifications	562
	7.4.6	Temperature Sensor Specifications	563
	7.4.7	Comparator Specifications	563
	7.4.8	USB PHY Specifications	564
7.5		Flash DC Electrical Characteristics	565
7.6		SPI Dynamic Characteristics	566
8		PACKAGE DIMENSIONS	568
	8.1	100L LQFP (14x14x1.4 mm footprint 2.0 mm).....	568
	8.2	64L LQFP (10x10x1.4mm footprint 2.0 mm).....	569
	8.3	48L LQFP (7x7x1.4 mm footprint 2.0 mm).....	570
9		REVISION HISTORY	572

List of Figures

Figure 3-1 NuMicro™ NUC100 Series Selection Code	22
Figure 3-2 NuMicro™ NUC130 LQFP 100-pin Assignment.....	23
Figure 3-3 NuMicro™ NUC130 LQFP 64-pin Assignment.....	24
Figure 3-4 NuMicro™ NUC130 LQFP 48-pin Assignment.....	25
Figure 3-5 NuMicro™ NUC140 LQFP 100-pin Assignment.....	26
Figure 3-6 NuMicro™ NUC140 LQFP 64-pin Assignment.....	27
Figure 3-7 NuMicro™ NUC140 LQFP 48-pin Assignment.....	28
Figure 4-1 NuMicro™ NUC130 Block Diagram	45
Figure 4-2 NuMicro™ NUC140 Block Diagram	46
Figure 5-1 Functional Controller Diagram.....	47
Figure 5-2 NuMicro™ NUC140 Power Distribution Diagram	50
Figure 5-3 NuMicro™ NUC130 Power Distribution Diagram	51
Figure 5-4 Clock Generator Global View Diagram.....	128
Figure 5-5 Clock Generator Block Diagram	129
Figure 5-6 System Clock Block Diagram	130
Figure 5-7 SysTick Clock Control Block Diagram	130
Figure 5-8 Clock Source of Frequency Divider	132
Figure 5-9 Block Diagram of Frequency Divider	132
Figure 5-10 USB Block Diagram	153
Figure 5-11 Wake-up Interrupt Operation Flow	155
Figure 5-12 Endpoint SRAM Structure	156
Figure 5-13 Setup Transaction followed by Data in Transaction.....	157
Figure 5-14 Data Out Transfer	158
Figure 5-15 Push-Pull Output.....	178
Figure 5-16 Open-Drain Output.....	179
Figure 5-17 Quasi-bidirectional I/O Mode	179
Figure 5-18 I ² C Bus Timing	200
Figure 5-19 I ² C Protocol.....	202
Figure 5-20 Master Transmits Data to Slave	202
Figure 5-21 Master Reads Data from Slave	202
Figure 5-22 START and STOP Conditions.....	203
Figure 5-23 Bit Transfer on I ² C Bus.....	204
Figure 5-24 Acknowledge on I ² C Bus.....	204

Figure 5-25 I ² C Data Shifting Direction	206
Figure 5-26: I ² C Time-out Count Block Diagram.....	208
Figure 5-27 Legend for the Following Five Figures.....	218
Figure 5-28 Master Transmitter Mode	219
Figure 5-29 Master Receiver Mode	220
Figure 5-30 Slave Receiver Mode	221
Figure 5-31 Slave Transmitter Mode	222
Figure 5-32 GC Mode	223
Figure 5-34 PWM Generator 0 Architecture Diagram	226
Figure 5-35 PWM Generator 2 Clock Source Control.....	227
Figure 5-36 PWM Generator 2 Architecture Diagram	227
Figure 5-37 PWM Generator 4 Clock Source Control.....	228
Figure 5-38 PWM Generator 4 Architecture Diagram	228
Figure 5-39 PWM Generator 6 Clock Source Control.....	229
Figure 5-40 PWM Generator 6 Architecture Diagram	229
Figure 5-41 Legend of Internal Comparator Output of PWM-Timer	230
Figure 5-42 PWM-Timer Operation Timing.....	231
Figure 5-43 PWM Double Buffering Illustration.....	232
Figure 5-44 PWM Controller Output Duty Ratio.....	233
Figure 5-45 Paired-PWM Output with Dead Zone Generation Operation	233
Figure 5-46 Capture Operation Timing	234
Figure 5-47 PWM Group A PWM-Timer Interrupt Architecture Diagram	235
Figure 5-48 PWM Group B PWM-Timer Interrupt Architecture Diagram	235
Figure 5-49 RTC Block Diagram	264
Figure 5-50 SPI Block Diagram	283
Figure 5-51 SPI Master Mode Application Block Diagram	284
Figure 5-52 SPI Slave Mode Application Block Diagram	284
Figure 5-53 Variable Serial Clock Frequency	286
Figure 5-54 32-Bit in One Transaction.....	286
Figure 5-55 Two Transactions in One Transfer (Burst Mode).....	287
Figure 5-56 Byte Reorder.....	288
Figure 5-58 Two Bits Transfer Mode (Slave Mode)	290
Figure 5-59 SPI Timing in Master Mode	291
Figure 5-60 SPI Timing in Master Mode (Alternate Phase of SPICLK)	292
Figure 5-61 SPI Timing in Slave Mode.....	292
Figure 5-62 SPI Timing in Slave Mode (Alternate Phase of SPICLK)	293



Figure 5-63 Timer Controller Block Diagram	310
Figure 5-64 Clock Source of Timer Controller	310
Figure 5-65 Continuous Counting Mode	312
Figure 5-66 Timing of Interrupt and Reset Signal	326
Figure 5-67 Watchdog Timer Clock Control.....	327
Figure 5-68 Watchdog Timer Block Diagram.....	327
Figure 5-69 UART Clock Control Diagram.....	334
Figure 5-70 UART Block Diagram	334
Figure 5-71 Auto Flow Control Block Diagram.....	336
Figure 5-72 IrDA Block Diagram.....	337
Figure 5-73 IrDA TX/RX Timing Diagram	338
Figure 5-74 Structure of LIN Frame.....	339
Figure 5-75 Structure of RS-485 Frame	341
Figure 5-76 CAN Peripheral Block Diagram	371
Figure 5-77 CAN Core in Silent Mode	373
Figure 5-78 CAN Core in Loop Back Mode	374
Figure 5-79 CAN Core in Loop Back Mode Combined with Silent Mode	374
Figure 5-80 Data Transfer between IFn Registers and Message.....	377
Figure 5-81 Application Software Handling of a FIFO Buffer	382
Figure 5-82 Bit Timing	384
Figure 5-83 Propagation Time Segment.....	386
Figure 5-84 Synchronization on “late” and “early” Edges	388
Figure 5-85 Filtering of Short Dominant Spikes	389
Figure 5-86 Structure of the CAN Core’s CAN Protocol Controller	391
Figure 5-87 PS/2 Device Block Diagram	436
Figure 5-88 Data Format of Device-to-Host.....	438
Figure 5-89 Data Format of Host-to-Device	438
Figure 5-90 PS/2 Bit Data Format	439
Figure 5-91 PS/2 Bus Timing	439
Figure 5-92 PS/2 Data Format	441
Figure 5-93 I ² S Clock Control Diagram.....	451
Figure 5-94 I ² S Controller Block Diagram.....	451
Figure 5-95 I ² S Bus Timing Diagram (Format =0).....	452
Figure 5-96 MSB Justified Timing Diagram (Format=1).....	452
Figure 5-97 FIFO contents for various I ² S modes.....	453
Figure 5-98 ADC Controller Block Diagram	468



Figure 5-99 ADC Converter Self-Calibration Timing Diagram	469
Figure 5-100 ADC Clock Control	470
Figure 5-101 Single Mode Conversion Timing Diagram	470
Figure 5-102 Single-Cycle Scan on Enabled Channels Timing Diagram	471
Figure 5-103 Continuous Scan on Enabled Channels Timing Diagram	472
Figure 5-105 A/D Controller Interrupt	474
Figure 5-106 ADC Single-end Input Conversion Voltage and Conversion Result Mapping Diagram	478
Figure 5-107 ADC Differential Input Conversion Voltage and Conversion Result Mapping Diagram	478
Figure 5-108 Analog Comparator Block Diagram	491
Figure 5-109 Comparator Controller Interrupt Sources	492
Figure 5-110 PDMA Controller Block Diagram	498
Figure 5-111 EBI Block Diagram	523
Figure 5-112 Connection of 16-bit EBI Data Width with 16-bit Device	524
Figure 5-113 Connection of 8-bit EBI Data Width with 8-bit Device	524
Figure 5-114 Timing Control Waveform for 16-bit Data Width	526
Figure 5-115 Timing Control Waveform for 8-bit Data Width	527
Figure 5-116 Timing Control Waveform for Insert Idle Cycle	528
Figure 6-1 Flash Memory Control Block Diagram	533
Figure 6-2 Flash Memory Organization	535
Figure 6-3 Flash Memory Structure	536
Figure 7-1 Typical Crystal Application Circuit	559
Figure 7-3 SPI Slave Dynamic Characteristics Timing	567



List of Tables

Table 1-1 Connectivity Support Table	12
Table 5-1 Address Space Assignments for On-Chip Controllers	53
Table 5-2 Exception Model.....	95
Table 5-3 System Interrupt Map	96
Table 5-4 Vector Table Format.....	97
Table 5-5 Power-down Mode Control Table	136
Table 5-6 I ² C Status Code Description Table	207
Table 5-7 Byte Order and Byte Suspend Conditions	289
Table 5-8 Watchdog Timeout Interval Selection	326
Table 5-9 UART Baud Rate Equation.....	331
Table 5-10 UART Baud Rate Setting Table.....	332
Table 5-11 UART Interrupt Sources and Flags Table in DMA Mode.....	362
Table 5-12 UART Interrupt Sources and Flags Table in Software Mode	362
Table 5-13 Baud Rate Equation Table	365
Table 5-14 Initialization of a Transmit Object.....	379
Table 5-16 CAN Bit Time Parameters	385
Table 5-17 CAN Register Map for Each Bit Function	399
Table 5-18 Error Codes.....	403
Table 5-19 Source of Interrupts.....	406
Table 5-20 IF1 and IF2 Message Interface Register	410
Table 5-21 Structure of a Message Object in Message Memory	424
Table 6-1 Memory Address Map	534
Table 6-2 ISP Mode	542



1 GENERAL DESCRIPTION

The NuMicro™ NUC100 Series 32-bit microcontroller is embedded with ARM® Cortex™-M0 core for industrial control and applications that need rich communication interfaces. The Cortex™-M0 is the newest ARM® embedded processor with 32-bit performance and at a cost equivalent to traditional 8-bit microcontroller. The NuMicro™ NUC100 Series includes NUC100, NUC120, NUC130 and NUC140 product lines.

The NuMicro™ NUC130 Automotive Line with CAN function is embedded with Cortex™-M0 core running up to 50 MHz with 32K/64K/128K bytes embedded flash, 4K/8K/16K bytes embedded SRAM, and 4 Kbytes loader ROM for the ISP. The NUC130 is also equipped with plenty of peripheral devices, such as Timers, Watchdog Timer, RTC, PDMA, UART, SPI, I²C, I²S, PWM Timer, GPIO, LIN, CAN, PS/2, 12-bit ADC, Analog Comparator, Low Voltage Reset Controller and Brown-out Detector.

The NuMicro™ NUC140 Connectivity Line with USB 2.0 full-speed and CAN functions is embedded with Cortex™-M0 core running up to 50 MHz with 32K/64K/128K bytes embedded flash, 4K/8K/16K bytes embedded SRAM, and 4 Kbytes loader ROM for the ISP. The NUC140 is also equipped with plenty of peripheral devices, such as Timers, Watchdog Timer, RTC, PDMA, UART, SPI, I²C, I²S, PWM Timer, GPIO, LIN, CAN, PS/2, USB 2.0 FS Device, 12-bit ADC, Analog Comparator, Low Voltage Reset Controller and Brown-out Detector.

Product Line	UART	SPI	I ² C	USB	LIN	CAN	PS/2	I ² S
NUC100	•	•	•				•	•
NUC120	•	•	•	•			•	•
NUC130	•	•	•		•	•	•	•
NUC140	•	•	•	•	•	•	•	•

Table 1-1 Connectivity Support Table



2 FEATURES

The equipped features are dependent on the product line and their sub products.

2.1 NuMicro™ NUC130 Features – Automotive Line

- Core
 - ARM® Cortex™-M0 core running up to 50 MHz
 - One 24-bit system timer
 - Supports low power sleep mode
 - Single-cycle 32-bit hardware multiplier
 - NVIC for the 32 interrupt inputs, each with 4-levels of priority
 - Serial Wire Debug supports with 2 watchpoints/4 breakpoints
- Build-in LDO for wide operating voltage ranges from 2.5 V to 5.5 V
- Flash Memory
 - 32K/64K/128K bytes Flash for program code
 - 4KB flash for ISP loader
 - Supports In-system program (ISP) application code update
 - 512 byte page erase for flash
 - Configurable data flash address and size for 128KB system, fixed 4KB data flash for the 32KB and 64KB system
 - Supports 2 wire ICP update through SWD/ICE interface
 - Supports fast parallel programming mode by external programmer
- SRAM Memory
 - 4K/8K/16K bytes embedded SRAM
 - Supports PDMA mode
- PDMA (Peripheral DMA)
 - Supports 9 channels PDMA for automatic data transfer between SRAM and peripherals
- Clock Control
 - Flexible selection for different applications
 - Built-in 22.1184 MHz high speed OSC for system operation
 - ◆ Trimmed to $\pm 1\%$ at $+25\text{ }^{\circ}\text{C}$ and $V_{DD} = 5\text{ V}$
 - ◆ Trimmed to $\pm 3\%$ at $-40\text{ }^{\circ}\text{C} \sim +85\text{ }^{\circ}\text{C}$ and $V_{DD} = 2.5\text{ V} \sim 5.5\text{ V}$
 - Built-in 10 kHz low speed OSC for Watchdog Timer and Wake-up operation
 - Supports one PLL, up to 50 MHz, for high performance system operation
 - External 4~24 MHz high speed crystal input for precise timing operation
 - External 32.768 kHz low speed crystal input for RTC function and low power system operation
- GPIO
 - Four I/O modes:
 - ◆ Quasi bi-direction
 - ◆ Push-Pull output
 - ◆ Open-Drain output
 - ◆ Input only with high impedance
 - TTL/Schmitt trigger input selectable
 - I/O pin configured as interrupt source with edge/level setting
 - Supports High Driver and High Sink I/O mode
- Timer

- Supports 4 sets of 32-bit timers with 24-bit up-timer and one 8-bit pre-scale counter
- Independent clock source for each timer
- Provides one-shot, periodic, toggle and continuous counting operation modes
- Support event counting function
- Support input capture function
- Watchdog Timer
 - Multiple clock sources
 - 8 selectable time out period from 1.6ms ~ 26.0sec (depending on clock source)
 - Wake-up from Power-down or Idle mode
 - Interrupt or reset selectable on watchdog time-out
- RTC
 - Supports software compensation by setting frequency compensate register (FCR)
 - Supports RTC counter (second, minute, hour) and calendar counter (day, month, year)
 - Supports Alarm registers (second, minute, hour, day, month, year)
 - Selectable 12-hour or 24-hour mode
 - Automatic leap year recognition
 - Supports periodic time tick interrupt with 8 period options 1/128, 1/64, 1/32, 1/16, 1/8, 1/4, 1/2 and 1 second
 - Supports wake-up function
- PWM/Capture
 - Up to four built-in 16-bit PWM generators providing eight PWM outputs or four complementary paired PWM outputs
 - Each PWM generator equipped with one clock source selector, one clock divider, one 8-bit prescaler and one Dead-Zone generator for complementary paired PWM
 - Up to eight 16-bit digital Capture timers (shared with PWM timers) provide eight rising/falling capture inputs
 - Supports Capture interrupt
- UART
 - Up to three UART controllers
 - UART ports with flow control (TXD, RXD, CTS and RTS)
 - UART0 with 64-byte FIFO is for high speed
 - UART1/2(optional) with 16-byte FIFO for standard device
 - Supports IrDA (SIR) and LIN function
 - Supports RS-485 9-bit mode and direction control.
 - Programmable baud-rate generator up to 1/16 system clock
 - Supports PDMA mode
- SPI
 - Up to four sets of SPI controller
 - Supports SPI master/Slave mode
 - Full duplex synchronous serial data transfer
 - Variable length of transfer data from 8 to 32 bits
 - MSB or LSB first data transfer
 - Rx and Tx on both rising or falling edge of serial clock independently
 - Two slave/device select lines when it is used as the master, and 1 slave/device select line when it is used as the slave
 - Supports byte suspend mode in 32-bit transmission
 - Supports PDMA mode
 - Supports three wire, no slave select signal, bi-direction interface



- I²C
 - Up to two sets of I²C device
 - Master/Slave mode
 - Bidirectional data transfer between masters and slaves
 - Multi-master bus (no central master)
 - Arbitration between simultaneously transmitting masters without corruption of serial data on the bus
 - Serial clock synchronization allows devices with different bit rates to communicate via one serial bus
 - Serial clock synchronization used as a handshake mechanism to suspend and resume serial transfer
 - Programmable clocks allow versatile rate control
 - Supports multiple address recognition (four slave address with mask option)
- I²S
 - Interface with external audio CODEC
 - Operated as either Master or Slave mode
 - Capable of handling 8-, 16-, 24- and 32-bit word sizes
 - Mono and stereo audio data supported
 - I²S and MSB justified data format supported
 - Two 8 word FIFO data buffers are provided, one for transmit and one for receive
 - Generates interrupt requests when buffer levels cross a programmable boundary
 - Supports two DMA requests, one for transmit and one for receive
- PS/2 Device Controller
 - Host communication inhibit and request to send detection
 - Reception frame error detection
 - Programmable 1 to 16 bytes transmit buffer to reduce CPU intervention
 - Double buffer for data reception
 - S/W override bus
- CAN 2.0
 - Supports CAN protocol version 2.0 part A and B
 - Bit rates up to 1M bit/s
 - 32 Message Objects
 - Each Message Object has its own identifier mask
 - Programmable FIFO mode (concatenation of Message Object)
 - Maskable interrupt
 - Disabled Automatic Re-transmission mode for Time Triggered CAN applications
 - Supports Power-down wake-up function
- EBI (External bus interface) support (100-pin and 64-pin Package Only)
 - Accessible space: 64KB in 8-bit mode or 128KB in 16-bit mode
 - Supports 8-/16-bit data width
 - Supports byte write in 16-bit data width mode
- ADC
 - 12-bit SAR ADC with 700K SPS
 - Up to 8-ch single-end input or 4-ch differential input
 - Single scan/single cycle scan/continuous scan
 - Each channel with individual result register
 - Scan on enabled channels
 - Threshold voltage detection
 - Conversion start by software programming or external input
 - Supports PDMA mode



- Analog Comparator
 - Up to two analog comparator
 - External input or internal band-gap voltage selectable at negative node
 - Interrupt when compare result change
 - Power-down wake-up
- One built-in temperature sensor with 1°C resolution
- Brown-out detector
 - With 4 levels: 4.5 V/3.8 V/2.7 V/2.2 V
 - Supports Brown-out Interrupt and Reset option
- Low Voltage Reset
 - Threshold voltage levels: 2.0 V
- Operating Temperature: -40°C~85°C
- Packages:
 - All Green package (RoHS)
 - LQFP 100-pin / 64-pin / 48-pin



2.2 NuMicro™ NUC140 Features – Connectivity Line

- Core
 - ARM® Cortex™-M0 core runs up to 50 MHz
 - One 24-bit system timer
 - Supports low power sleep mode
 - Single-cycle 32-bit hardware multiplier
 - NVIC for the 32 interrupt inputs, each with 4-levels of priority
 - Serial Wire Debug supports with 2 watchpoints/4 breakpoints
- Build-in LDO for wide operating voltage ranges from 2.5 V to 5.5 V
- Flash Memory
 - 32K/64K/128K bytes Flash for program code
 - 4KB flash for ISP loader
 - Support In-system program (ISP) application code update
 - 512 byte page erase for flash
 - Configurable data flash address and size for 128KB system, fixed 4KB data flash for the 32KB and 64KB system
 - Support 2 wire ICP update through SWD/ICE interface
 - Support fast parallel programming mode by external programmer
- SRAM Memory
 - 4K/8K/16K bytes embedded SRAM
 - Support PDMA mode
- PDMA (Peripheral DMA)
 - Support 9 channels PDMA for automatic data transfer between SRAM and peripherals
- Clock Control
 - Flexible selection for different applications
 - Built-in 22.1184 MHz high speed OSC for system operation
 - ◆ Trimmed to $\pm 1\%$ at $+25\text{ }^{\circ}\text{C}$ and $V_{DD} = 5\text{ V}$
 - ◆ Trimmed to $\pm 3\%$ at $-40\text{ }^{\circ}\text{C} \sim +85\text{ }^{\circ}\text{C}$ and $V_{DD} = 2.5\text{ V} \sim 5.5\text{ V}$
 - Built-in 10 kHz low speed OSC for Watchdog Timer and Wake-up operation
 - Support one PLL, up to 50 MHz, for high performance system operation
 - External 4~24 MHz high speed crystal input for USB and precise timing operation
 - External 32.768 kHz low speed crystal input for RTC function and low power system operation
- GPIO
 - Four I/O modes:
 - ◆ Quasi bi-direction
 - ◆ Push-Pull output
 - ◆ Open-Drain output
 - ◆ Input only with high impedance
 - TTL/Schmitt trigger input selectable
 - I/O pin configured as interrupt source with edge/level setting
 - Supports High Driver and High Sink I/O mode
- Timer
 - Supports 4 sets of 32-bit timers with 24-bit up-timer and one 8-bit pre-scale counter
 - Independent clock source for each timer



- Provides one-shot, periodic, toggle and continuous counting operation modes
- Supports event counting function
- Supports input capture function
- Watchdog Timer
 - Multiple clock sources
 - 8 selectable time out period from 1.6ms ~ 26.0sec (depending on clock source)
 - Wake-up from Power-down or Idle mode
 - Interrupt or reset selectable on watchdog time-out
- RTC
 - Support software compensation by setting frequency compensate register (FCR)
 - Support RTC counter (second, minute, hour) and calendar counter (day, month, year)
 - Support Alarm registers (second, minute, hour, day, month, year)
 - Selectable 12-hour or 24-hour mode
 - Automatic leap year recognition
 - Support periodic time tick interrupt with 8 period options 1/128, 1/64, 1/32, 1/16, 1/8, 1/4, 1/2 and 1 second
 - Support wake-up function
- PWM/Capture
 - Built-in up to four 16-bit PWM generators provide eight PWM outputs or four complementary paired PWM outputs
 - Each PWM generator equipped with one clock source selector, one clock divider, one 8-bit prescaler and one Dead-Zone generator for complementary paired PWM
 - Up to eight 16-bit digital Capture timers (shared with PWM timers) provide eight rising/falling capture inputs
 - Support Capture interrupt
- UART
 - Up to three UART controllers
 - UART ports with flow control (TXD, RXD, CTS and RTS)
 - UART0 with 64-byte FIFO is for high speed
 - UART1/2(optional) with 16-byte FIFO for standard device
 - Support IrDA (SIR) and LIN function
 - Support RS-485 9-bit mode and direction control.
 - Programmable baud-rate generator up to 1/16 system clock
 - Support PDMA mode
- SPI
 - Up to four sets of SPI controller
 - Supports SPI master/Slave mode
 - Full duplex synchronous serial data transfer
 - Variable length of transfer data from 8 to 32 bits
 - MSB or LSB first data transfer
 - Rx and Tx on both rising or falling edge of serial clock independently
 - 2 slave/device select lines when it is as the master, and 1 slave/device select line when it is as the slave
 - Support byte suspend mode in 32-bit transmission
 - Support PDMA mode
 - Support three wire, no slave select signal, bi-direction interface



- I²C
 - Up to two sets of I²C device
 - Master/Slave mode
 - Bidirectional data transfer between masters and slaves
 - Multi-master bus (no central master)
 - Arbitration between simultaneously transmitting masters without corruption of serial data on the bus
 - Serial clock synchronization allows devices with different bit rates to communicate via one serial bus
 - Serial clock synchronization used as a handshake mechanism to suspend and resume serial transfer
 - Programmable clocks allow versatile rate control
 - Support multiple address recognition (four slave addresses with mask option)
- I²S
 - Interface with external audio CODEC
 - Operated as either Master or Slave mode
 - Capable of handling 8-, 16-, 24- and 32-bit word sizes
 - Mono and stereo audio data supported
 - I²S and MSB justified data format supported
 - Two 8 word FIFO data buffers are provided, one for transmit and one for receive
 - Generates interrupt requests when buffer levels cross a programmable boundary
 - Support two DMA requests, one for transmit and one for receive
- CAN 2.0
 - Supports CAN protocol version 2.0 part A and B
 - Bit rates up to 1M bit/s
 - 32 Message Objects
 - Each Message Object has its own identifier mask
 - Programmable FIFO mode (concatenation of Message Object)
 - Maskable interrupt
 - Disabled Automatic Re-transmission mode for Time Triggered CAN applications
 - Support power down wake-up function
- PS/2 Device Controller
 - Host communication inhibit and request to send detection
 - Reception frame error detection
 - Programmable 1 to 16 bytes transmit buffer to reduce CPU intervention
 - Double buffer for data reception
 - S/W override bus
- USB 2.0 Full-Speed Device
 - One set of USB 2.0 FS Device 12Mbps
 - On-chip USB Transceiver
 - Provide 1 interrupt source with 4 interrupt events
 - Support Control, Bulk In/Out, Interrupt and Isochronous transfers
 - Auto suspend function when no bus signaling for 3 ms
 - Provide 6 programmable endpoints
 - Include 512 Bytes internal SRAM as USB buffer
 - Provide remote wake-up capability
- EBI (External bus interface) support (100-pin and 64-pin Package Only)
 - Accessible space: 64KB in 8-bit mode or 128KB in 16-bit mode
 - Support 8-/16-bit data width
 - Support byte write in 16-bit data width mode



- ADC
 - 12-bit SAR ADC with 700K SPS
 - Up to 8-ch single-end input or 4-ch differential input
 - Single scan/single cycle scan/continuous scan
 - Each channel with individual result register
 - Scan on enabled channels
 - Threshold voltage detection
 - Conversion start by software programming or external input
 - Support PDMA Mode
- Analog Comparator
 - Up to two analog comparators
 - External input or internal band-gap voltage selectable at negative node
 - Interrupt when compare result change
 - Power down wake-up
- One built-in temperature sensor with 1°C resolution
- Brown-out detector
 - With 4 levels: 4.5 V/3.8 V/2.7 V/2.2 V
 - Support Brown-out Interrupt and Reset option
- Low Voltage Reset
 - Threshold voltage levels: 2.0 V
- Operating Temperature: -40°C~85°C
- Packages:
 - All Green package (RoHS)
 - LQFP 100-pin / 64-pin / 48-pin



3 PARTS INFORMATION LIST AND PIN CONFIGURATION

3.1 NuMicro™ NUC130 Products Selection Guide

3.1.1 NuMicro™ NUC130 Automotive Line Selection Guide

Part number	APROM	RAM	Data Flash	ISP Loader ROM	I/O	Timer	Connectivity						I ² S	Comp.	PWM	ADC	RTC	EBI	ISP ICP	Package
							UART	SPI	I ² C	USB	LIN	CAN								
NUC130LC1CN	32 KB	4 KB	4 KB	4 KB	up to 35	4x32-bit	3	1	2	-	2	1	1	1	4	8x12-bit	v	-	v	LQFP48
NUC130LD2CN	64 KB	8 KB	4 KB	4 KB	up to 35	4x32-bit	3	1	2	-	2	1	1	1	4	8x12-bit	v	-	v	LQFP48
NUC130LE3CN	128 KB	16 KB	Definable	4 KB	up to 35	4x32-bit	3	1	2	-	2	1	1	1	4	8x12-bit	v	-	v	LQFP48
NUC130RC1CN	32 KB	4 KB	4 KB	4 KB	up to 49	4x32-bit	3	2	2	-	2	1	1	2	6	8x12-bit	v	v	v	LQFP64
NUC130RD2CN	64 KB	8 KB	4 KB	4 KB	up to 49	4x32-bit	3	2	2	-	2	1	1	2	6	8x12-bit	v	v	v	LQFP64
NUC130RE3CN	128 KB	16 KB	Definable	4 KB	up to 49	4x32-bit	3	2	2	-	2	1	1	2	6	8x12-bit	v	v	v	LQFP64
NUC130VE3CN	128 KB	16 KB	Definable	4 KB	up to 80	4x32-bit	3	4	2	-	2	1	1	2	8	8x12-bit	v	v	v	LQFP100



3.2 NuMicro™ NUC140 Products Selection Guide

3.2.1 NuMicro™ NUC140 Connectivity Line Selection Guide

Part number	APROM	RAM	Data Flash	ISP Loader ROM	I/O	Timer	Connectivity					I ² S	Comp.	PWM	ADC	RTC	EBI	ISP ICP	Package	
							UART	SPI	I ² C	USB	LIN									CAN
NUC140LC1CN	32 KB	4 KB	4 KB	4 KB	up to 31	4x32-bit	2	1	2	1	2	1	1	1	4	8x12-bit	v	-	v	LQFP48
NUC140LD2CN	64 KB	8 KB	4 KB	4 KB	up to 31	4x32-bit	2	1	2	1	2	1	1	1	4	8x12-bit	v	-	v	LQFP48
NUC140LE3CN	128 KB	16 KB	Definable	4 KB	up to 31	4x32-bit	2	1	2	1	2	1	1	1	4	8x12-bit	v	-	v	LQFP48
NUC140RC1CN	32 KB	4 KB	4 KB	4 KB	up to 45	4x32-bit	3	2	2	1	2	1	1	2	4	8x12-bit	v	v	v	LQFP64
NUC140RD2CN	64 KB	8 KB	4 KB	4 KB	up to 45	4x32-bit	3	2	2	1	2	1	1	2	4	8x12-bit	v	v	v	LQFP64
NUC140RE3CN	128 KB	16 KB	Definable	4 KB	up to 45	4x32-bit	3	2	2	1	2	1	1	2	4	8x12-bit	v	v	v	LQFP64
NUC140VE3CN	128 KB	16 KB	Definable	4 KB	up to 76	4x32-bit	3	4	2	1	2	1	1	2	8	8x12-bit	v	v	v	LQFP100

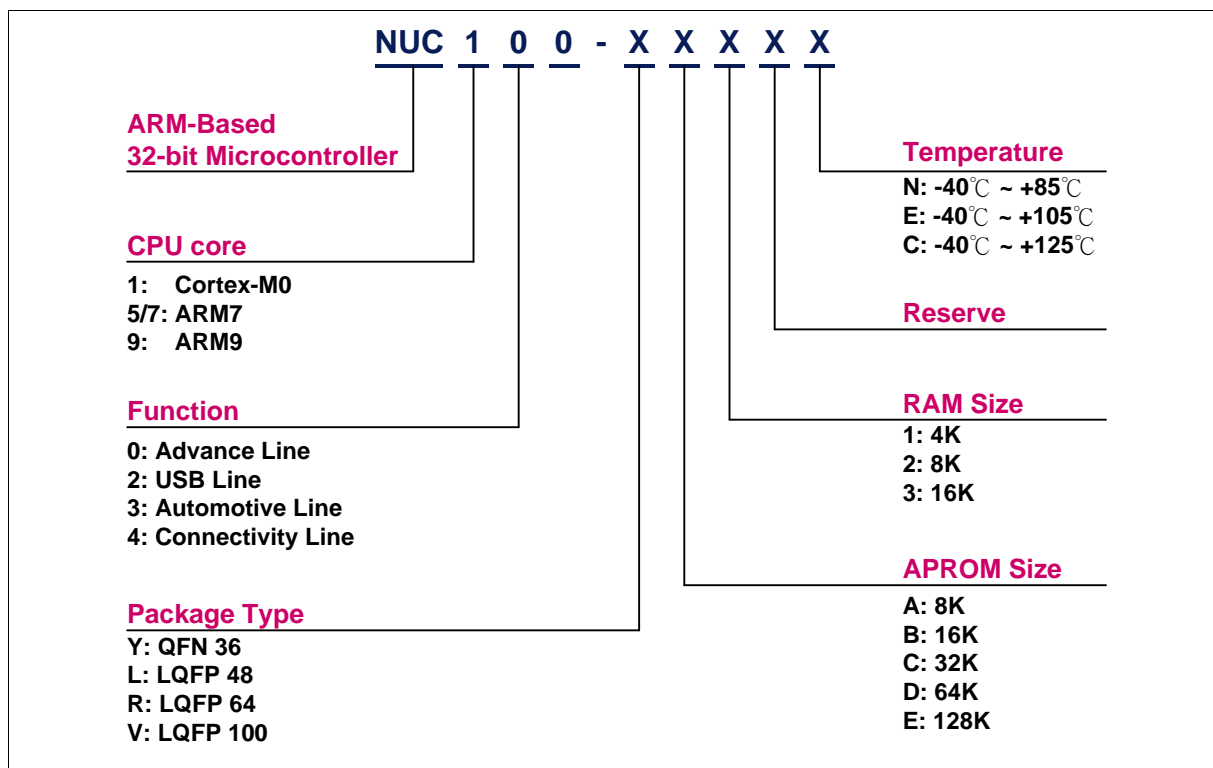

Figure 3-1 NuMicro™ NUC100 Series Selection Code



3.3 Pin Configuration

3.3.1 NuMicro™ NUC130/NUC140 Pin Diagram

3.3.1.1 NuMicro™ NUC130 LQFP 100 pin

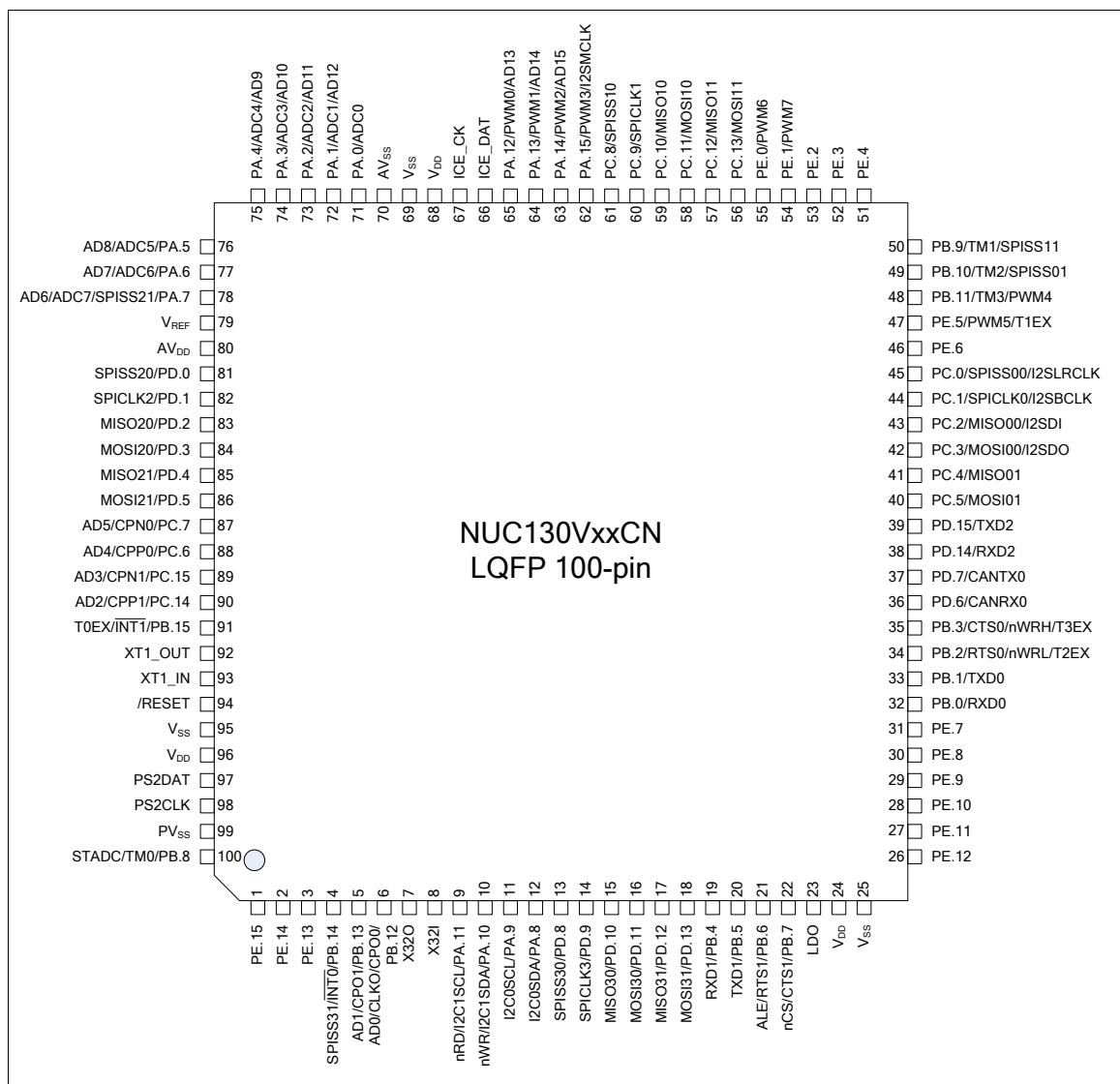

Figure 3-2 NuMicro™ NUC130 LQFP 100-pin Assignment



3.3.1.2 NuMicro™ NUC130 LQFP 64 pin

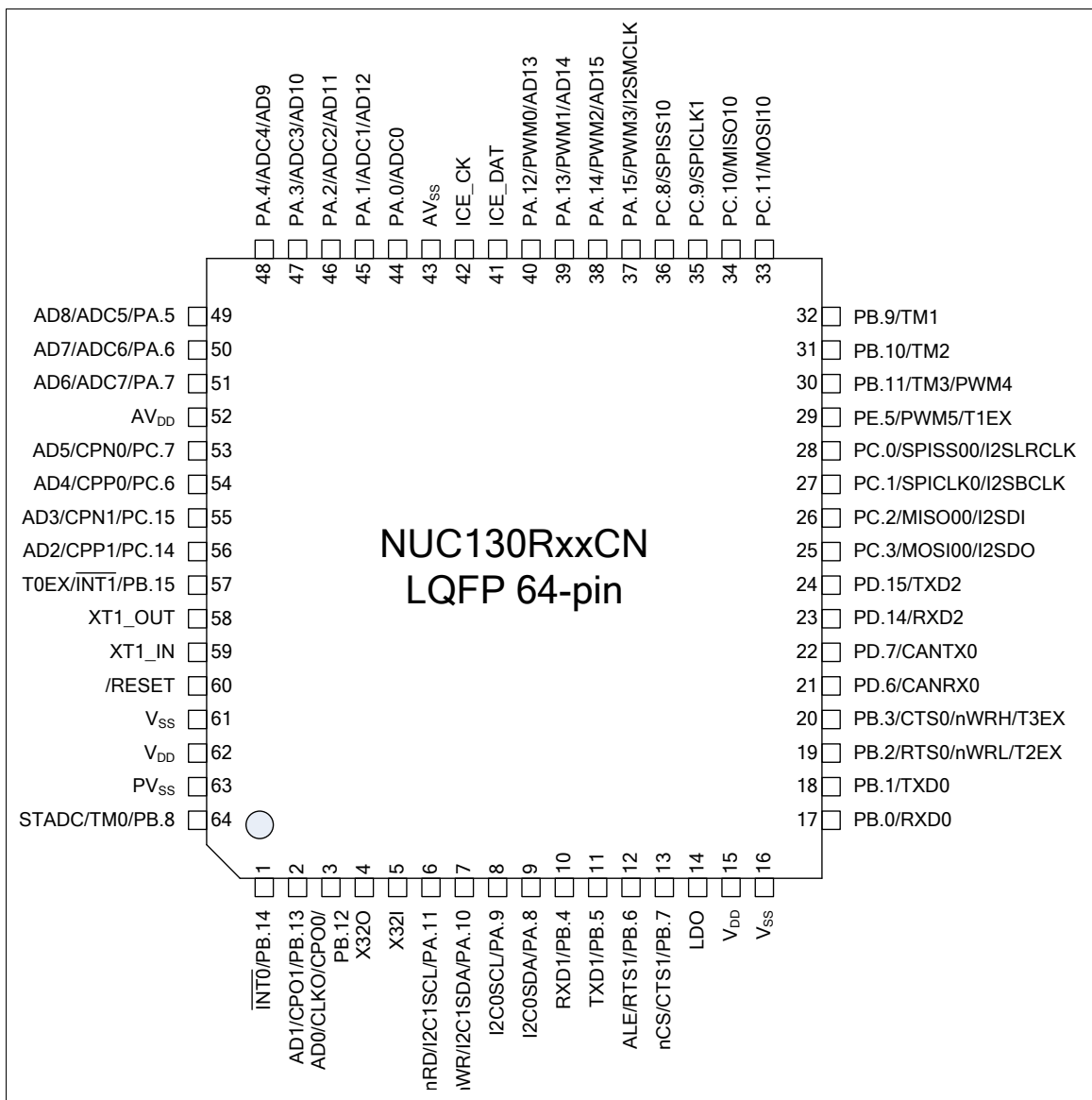

Figure 3-3 NuMicro™ NUC130 LQFP 64-pin Assignment



3.3.1.3 NuMicro™ NUC130 LQFP 48 pin

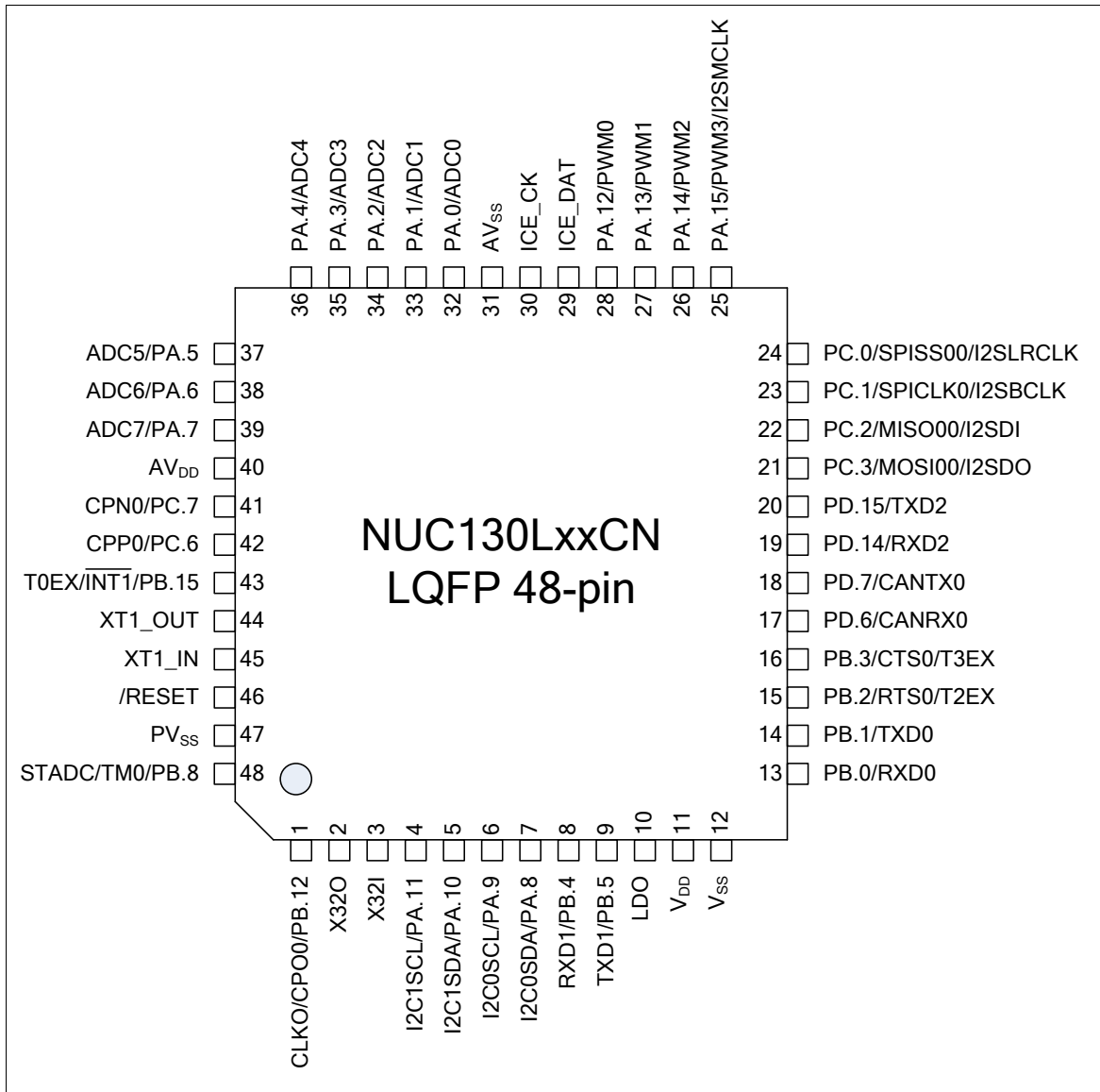

Figure 3-4 NuMicro™ NUC130 LQFP 48-pin Assignment



3.3.1.4 NuMicro™ NUC140 LQFP 100 pin

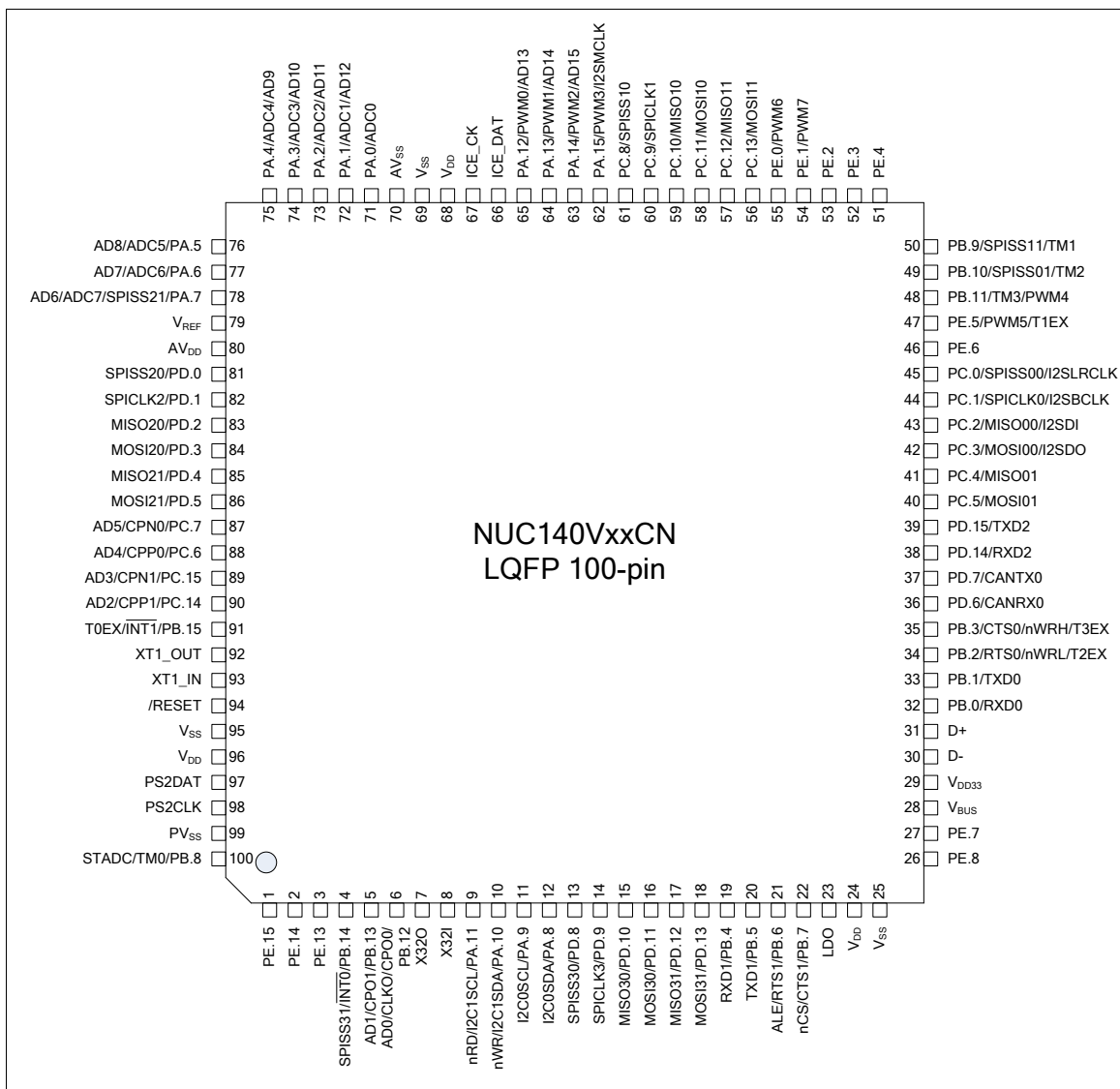

Figure 3-5 NuMicro™ NUC140 LQFP 100-pin Assignment



3.3.1.5 NuMicro™ NUC140 LQFP 64 pin

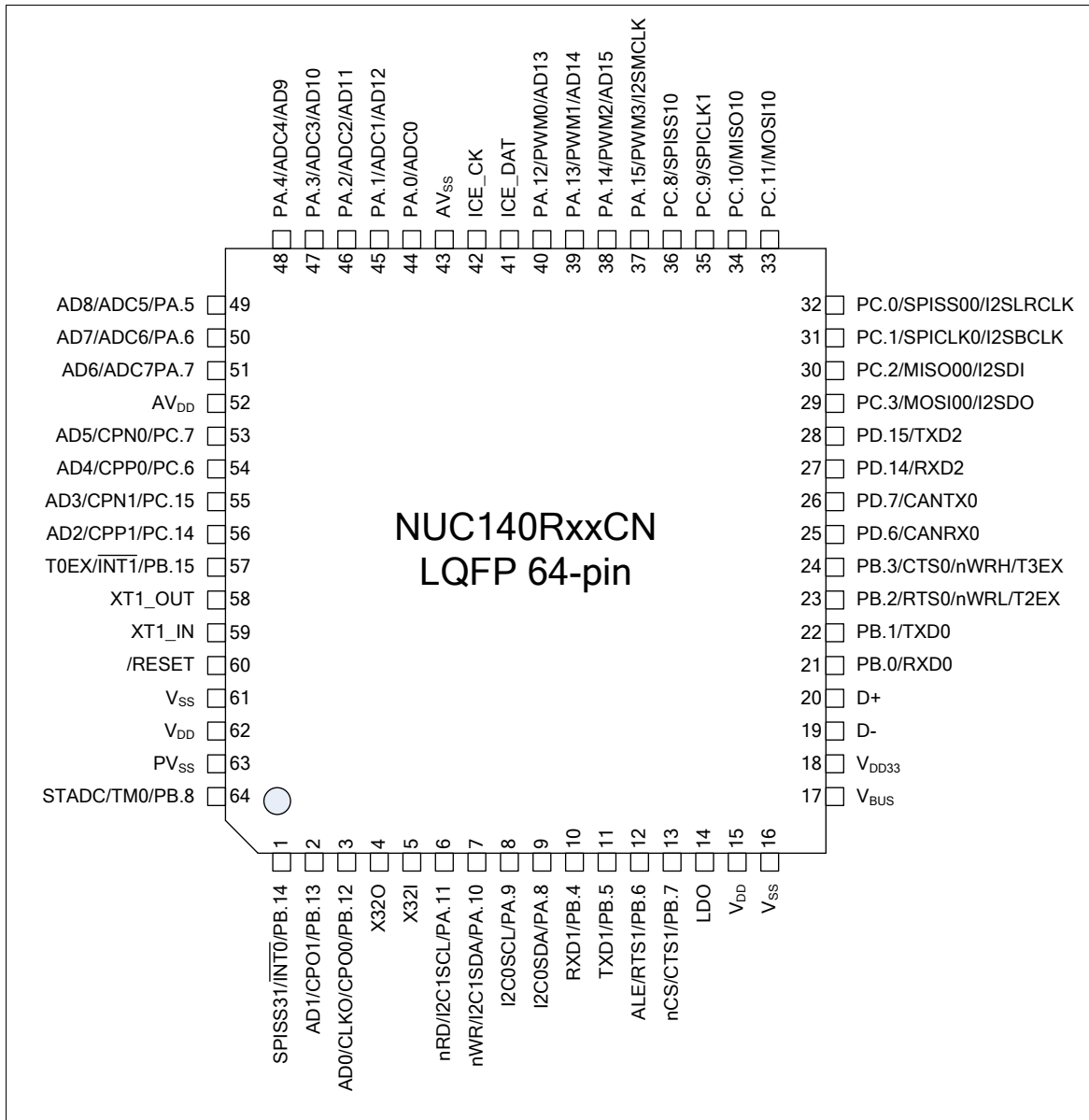

Figure 3-6 NuMicro™ NUC140 LQFP 64-pin Assignment



3.3.1.6 NuMicro™ NUC140 LQFP 48 pin

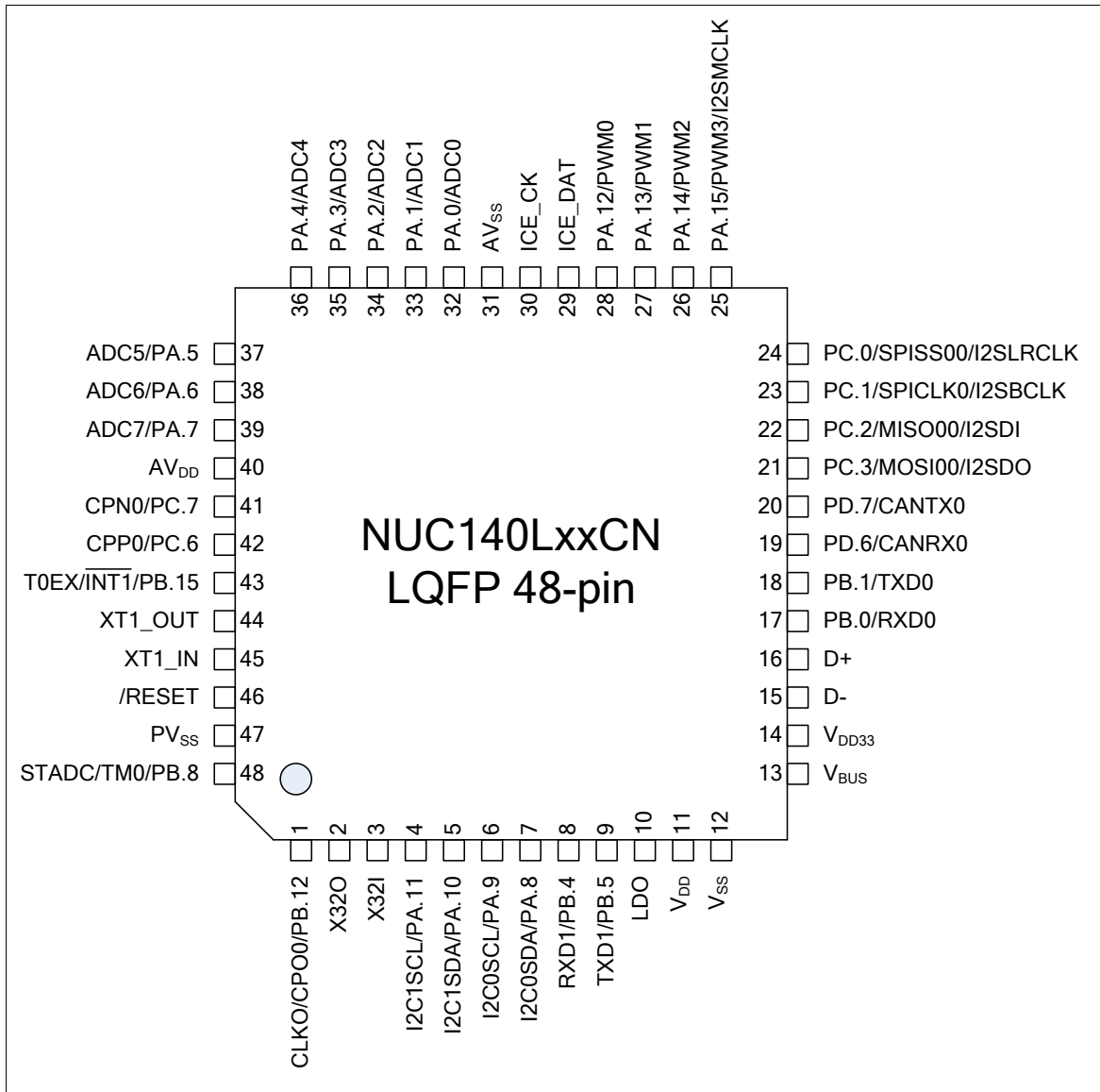

Figure 3-7 NuMicro™ NUC140 LQFP 48-pin Assignment



3.4 Pin Description

3.4.1 NuMicro™ NUC130/NUC140 Pin Description

3.4.1.1 NuMicro™ NUC130 Pin Description

Pin No.			Pin Name	Type	Description
LQFP 100-pin	LQFP 64-pin	LQFP 48-pin			
1			PE.15	I/O	Digital GPIO pin
2			PE.14	I/O	Digital GPIO pin
3			PE.13	I/O	Digital GPIO pin
4	1		PB.14	I/O	Digital GPIO pin
			/INT0	I	/INT0: External interrupt1 input pin
			SPISS31	I/O	SPISS31: SPI3 2 nd slave select pin
5	2		PB.13	I/O	Digital GPIO pin
			CPO1	O	Comparator1 output pin
			AD1	I/O	EBI Address/Data bus bit1
6	3	1	PB.12	I/O	Digital GPIO pin
			CPO0	O	Comparator0 output pin
			CLKO	O	Frequency Divider output pin
			AD0	I/O	EBI Address/Data bus bit0
7	4	2	X32O	O	External 32.768 kHz low speed crystal output pin
8	5	3	X32I	I	External 32.768 kHz low speed crystal input pin
9	6	4	PA.11	I/O	Digital GPIO pin
			I2C1SCL	I/O	I2C1SCL: I ² C1 clock pin
		nRD	O	EBI read enable output pin	
10	7	5	PA.10	I/O	Digital GPIO pin
			I2C1SDA	I/O	I2C1SDA: I ² C1 data I/O pin
		nWR	O	EBI write enable output pin	
11	8	6	PA.9	I/O	Digital GPIO pin
			I2C0SCL	I/O	I2C0SCL: I ² C0 clock pin
12	9	7	PA.8	I/O	Digital GPIO pin
			I2C0SDA	I/O	I2C0SDA: I ² C0 data I/O pin
13			PD.8	I/O	Digital GPIO pin



Pin No.			Pin Name	Type	Description
LQFP 100-pin	LQFP 64-pin	LQFP 48-pin			
			SPISS30	I/O	SPISS30: SPI3 slave select pin
14			PD.9	I/O	Digital GPIO pin
			SPICLK3	I/O	SPICLK3: SPI3 serial clock pin
15			PD.10	I/O	Digital GPIO pin
			MISO30	I/O	MISO30: SPI3 MISO (Master In, Slave Out) pin
16			PD.11	I/O	Digital GPIO pin
			MOSI30	I/O	MOSI30: SPI3 MOSI (Master Out, Slave In) pin
17			PD.12	I/O	Digital GPIO pin
			MISO31	I/O	MISO31: SPI3 2 nd MISO (Master In, Slave Out) pin
18			PD.13	I/O	Digital GPIO pin
			MOSI31	I/O	MOSI31: SPI3 2 nd MOSI (Master Out, Slave In) pin
19	10	8	PB.4	I/O	Digital GPIO pin
			RXD1	I	RXD1: Data receiver input pin for UART1
20	11	9	PB.5	I/O	Digital GPIO pin
			TXD1	O	TXD1: Data transmitter output pin for UART1
21	12		PB.6	I/O	Digital GPIO pin
			RTS1	O	RTS1: Request to Send output pin for UART1
			ALE	O	EBI address latch enable output pin
22	13		PB.7	I/O	Digital GPIO pin
			CTS1	I	CTS1: Clear to send input pin for UART1
			nCS	O	EBI chip select enable output pin
23	14	10	LDO	P	LDO output pin
24	15	11	V _{DD}	P	Power supply for I/O ports and LDO source for internal PLL and digital function
25	16	12	V _{SS}	P	Ground
26			PE.12	I/O	Digital GPIO pin
27			PE.11	I/O	Digital GPIO pin
28			PE.10	I/O	Digital GPIO pin
29			PE.9	I/O	Digital GPIO pin
30			PE.8	I/O	Digital GPIO pin



Pin No.			Pin Name	Type	Description
LQFP 100-pin	LQFP 64-pin	LQFP 48-pin			
31			PE.7	I/O	Digital GPIO pin
32	17	13	PB.0	I/O	Digital GPIO pin
			RXD0	I	RXD0: Data receiver input pin for UART0
33	18	14	PB.1	I/O	Digital GPIO pin
			TXD0	O	TXD0: Data transmitter output pin for UART0
34	19	15	PB.2	I/O	Digital GPIO pin
			RTS0	O	RTS0: Request to Send output pin for UART0
			nWRL	O	EBI low byte write enable output pin
			T2EX	I	Timer2 external capture input pin
35	20	16	PB.3	I/O	Digital GPIO pin
			CTS0	I	CTS0: Clear to Send input pin for UART0
			nWRH	O	EBI high byte write enable output pin
			T3EX	I	Timer3 external capture input pin
36	21	17	PD.6	I/O	Digital GPIO pin
			CANRX0	I	CAN Bus0 RX Input
37	22	18	PD.7	I/O	Digital GPIO pin
			CANTX0	O	CAN Bus0 TX Output
38	23	19	PD.14	I/O	Digital GPIO pin
			RXD2	I	RXD2: Data receiver input pin for UART2
39	24	20	PD.15	I/O	Digital GPIO pin
			TXD2	O	TXD2: Data transmitter output pin for UART2
40			PC.5	I/O	Digital GPIO pin
			MOSI01	I/O	MOSI01: SPI0 2 nd MOSI (Master Out, Slave In) pin
41			PC.4	I/O	Digital GPIO pin
			MISO01	I/O	MISO01: SPI0 2 nd MISO (Master In, Slave Out) pin
42	25	21	PC.3	I/O	Digital GPIO pin
			MOSI00	I/O	MOSI00: SPI0 MOSI (Master Out, Slave In) pin
			I2SDO	O	I2SDO: I ² S data output
43	26	22	PC.2	I/O	Digital GPIO pin
			MISO00	I/O	MISO00: SPI0 MISO (Master In, Slave Out) pin



Pin No.			Pin Name	Type	Description
LQFP 100-pin	LQFP 64-pin	LQFP 48-pin			
			I2SDI	I	I2SDI: I ² S data input
44	27	23	PC.1	I/O	Digital GPIO pin
			SPICLK0	I/O	SPICLK0: SPI0 serial clock pin
			I2SBCLK	I/O	I2SBCLK: I ² S bit clock pin
45	28	24	PC.0	I/O	Digital GPIO pin
			SPISS00	I/O	SPISS00: SPI0 slave select pin
			I2SLRCLK	I/O	I2SLRCLK: I ² S left right channel clock
46			PE.6	I/O	Digital GPIO pin
47	29		PE.5	I/O	Digital GPIO pin
			PWM5	I/O	PWM5: PWM output/Capture input
			T1EX	I	Timer1 external capture input
48	30		PB.11	I/O	Digital GPIO pin
			TM3	I/O	TM3: Timer3 event counter input / toggle output
			PWM4	I/O	PWM4: PWM output/Capture input
49	31		PB.10	I/O	Digital GPIO pin
			TM2	I/O	TM2: Timer2 event counter input / toggle output
				SPISS01	I/O
50	32		PB.9	I/O	Digital GPIO pin
			TM1	I/O	TM1: Timer1 event counter input / toggle output
				SPISS11	I/O
51			PE.4	I/O	Digital GPIO pin
52			PE.3	I/O	Digital GPIO pin
53			PE.2	I/O	Digital GPIO pin
54			PE.1	I/O	Digital GPIO pin
			PWM7	I/O	PWM7: PWM output/Capture input
55			PE.0	I/O	Digital GPIO pin
			PWM6	I/O	PWM6: PWM output/Capture input
56			PC.13	I/O	Digital GPIO pin
			MOSI11	I/O	MOSI11: SPI1 2 nd MOSI (Master Out, Slave In) pin
57			PC.12	I/O	Digital GPIO pin



Pin No.			Pin Name	Type	Description
LQFP 100-pin	LQFP 64-pin	LQFP 48-pin			
			MISO11	I/O	MISO11: SPI1 2 nd MISO (Master In, Slave Out) pin
58	33		PC.11	I/O	Digital GPIO pin
			MOSI10	I/O	MOSI10: SPI1 MOSI (Master Out, Slave In) pin
59	34		PC.10	I/O	Digital GPIO pin
			MISO10	I/O	MISO10: SPI1 MISO (Master In, Slave Out) pin
60	35		PC.9	I/O	Digital GPIO pin
			SPICLK1	I/O	SPICLK1: SPI1 serial clock pin
61	36		PC.8	I/O	Digital GPIO pin
			SPISS10	I/O	SPISS10: SPI1 slave select pin
			MCLK	O	EBI clock output
62	37	25	PA.15	I/O	Digital GPIO pin
			PWM3	I/O	PWM3: PWM output/Capture input
			I2SMCLK	O	I2SMCLK: I ² S master clock output pin
63	38	26	PA.14	I/O	Digital GPIO pin
			PWM2	I/O	PWM2: PWM output/Capture input
			AD15	I/O	EBI Address/Data bus bit15
64	39	27	PA.13	I/O	Digital GPIO pin
			PWM1	I/O	PWM1: PWM output/Capture input
			AD14	I/O	EBI Address/Data bus bit14
65	40	28	PA.12	I/O	Digital GPIO pin
			PWM0	I/O	PWM0: PWM output/Capture input
			AD13	I/O	EBI Address/Data bus bit13
66	41	29	ICE_DAT	I/O	Serial Wired Debugger Data pin
67	42	30	ICE_CK	I	Serial Wired Debugger Clock pin
68			V _{DD}	P	Power supply for I/O ports and LDO source for internal PLL and digital circuit
69			V _{SS}	P	Ground
70	43	31	AV _{SS}	AP	Ground Pin for analog circuit
71	44	32	PA.0	I/O	Digital GPIO pin
			ADC0	AI	ADC0: ADC analog input



Pin No.			Pin Name	Type	Description
LQFP 100-pin	LQFP 64-pin	LQFP 48-pin			
72	45	33	PA.1	I/O	Digital GPIO pin
			ADC1	AI	ADC1: ADC analog input
			AD12	I/O	EBI Address/Data bus bit12
73	46	34	PA.2	I/O	Digital GPIO pin
			ADC2	AI	ADC2: ADC analog input
			AD11	I/O	EBI Address/Data bus bit11
74	47	35	PA.3	I/O	Digital GPIO pin
			ADC3	AI	ADC3: ADC analog input
			AD10	I/O	EBI Address/Data bus bit10
75	48	36	PA.4	I/O	Digital GPIO pin
			ADC4	AI	ADC4: ADC analog input
			AD9	I/O	EBI Address/Data bus bit9
76	49	37	PA.5	I/O	Digital GPIO pin
			ADC5	AI	ADC5: ADC analog input
			AD8	I/O	EBI Address/Data bus bit8
77	50	38	PA.6	I/O	Digital GPIO pin
			ADC6	AI	ADC6: ADC analog input
			AD7	I/O	EBI Address/Data bus bit7
78	51	39	PA.7	I/O	Digital GPIO pin
			ADC7	AI	ADC7: ADC analog input
			SPISS21	I/O	SPISS21: SPI2 2 nd slave select pin
			AD6	I/O	EBI Address/Data bus bit6
79			VREF	AP	Voltage reference input for ADC
80	52	40	AV _{DD}	AP	Power supply for internal analog circuit
81			PD.0	I/O	Digital GPIO pin
			SPISS20	I/O	SPISS20: SPI2 slave select pin
82			PD.1	I/O	Digital GPIO pin
			SPICLK2	I/O	SPICLK2: SPI2 serial clock pin
83			PD.2	I/O	Digital GPIO pin
			MISO20	I/O	MISO20: SPI2 MISO (Master In, Slave Out) pin



Pin No.			Pin Name	Type	Description
LQFP 100-pin	LQFP 64-pin	LQFP 48-pin			
84			PD.3	I/O	Digital GPIO pin
			MOSI20	I/O	MOSI20: SPI2 MOSI (Master Out, Slave In) pin
85			PD.4	I/O	Digital GPIO pin
			MISO21	I/O	MISO21: SPI2 2 nd MISO (Master In, Slave Out) pin
86			PD.5	I/O	Digital GPIO pin
			MOSI21	I/O	MOSI21: SPI2 2 nd MOSI (Master Out, Slave In) pin
87	53	41	PC.7	I/O	Digital GPIO pin
			CPN0	AI	CPN0: Comparator0 Negative input pin
			AD5	I/O	EBI Address/Data bus bit5
88	54	42	PC.6	I/O	Digital GPIO pin
			CPP0	AI	CPP0: Comparator0 Positive input pin
			AD4	I/O	EBI Address/Data bus bit4
89	55		PC.15	I/O	Digital GPIO pin
			CPN1	AI	CPN1: Comparator1 Negative input pin
			AD3	I/O	EBI Address/Data bus bit3
90	56		PC.14	I/O	Digital GPIO pin
			CPP1	AI	CPP1: Comparator1 Positive input pin
			AD2	I/O	EBI Address/Data bus bit2
91	57	43	PB.15	I/O	Digital GPIO pin
			/INT1	I	/INT1: External interrupt0 input pin
			T0EX	I	Timer0 external capture input
92	58	44	XT1_OUT	O	External 4~24 MHz high speed crystal output pin
93	59	45	XT1_IN	I	External 4~24 MHz high speed crystal input pin
94	60	46	/RESET	I	External reset input: Low active, set this pin low reset chip to initial state. With internal pull-up.
95	61		V _{SS}	P	Ground
96	62		V _{DD}	P	Power supply for I/O ports and LDO source for internal PLL and digital circuit
97			PS2DAT	I/O	PS/2 Data pin
98			PS2CLK	I/O	PS/2 clock pin
99	63	47	PV _{SS}	P	PLL Ground



Pin No.			Pin Name	Type	Description
LQFP 100-pin	LQFP 64-pin	LQFP 48-pin			
100	64	48	PB.8	I/O	Digital GPIO pin
			STADC	I	STADC: ADC external trigger input.
			TM0	I/O	TM0: Timer0 event counter input / toggle output

Note: Pin Type: I = Digital Input, O = Digital Output; AI = Analog Input; P = Power Pin; AP = Analog Power



3.4.1.2 NuMicro™ NUC140 Pin Description

Pin No.			Pin Name	Type	Description
LQFP 100-pin	LQFP 64-pin	LQFP 48-pin			
1			PE.15	I/O	Digital GPIO pin
2			PE.14	I/O	Digital GPIO pin
3			PE.13	I/O	Digital GPIO pin
4	1		PB.14	I/O	Digital GPIO pin
			/INT0	I	/INT0: External interrupt1 input pin
			SPISS31	I/O	SPISS31: SPI3 2 nd slave select pin
5	2		PB.13	I/O	Digital GPIO pin
			CPO1	O	Comparator1 output pin
			AD1	I/O	EBI Address/Data bus bit1
6	3	1	PB.12	I/O	Digital GPIO pin
			CPO0	O	Comparator0 output pin
			CLKO	O	Frequency Divider output pin
			AD0	I/O	EBI Address/Data bus bit0
7	4	2	X32O	O	External 32.768 kHz low speed crystal output pin
8	5	3	X32I	I	External 32.768 kHz low speed crystal input pin
9	6	4	PA.11	I/O	Digital GPIO pin
			I2C1SCL	I/O	I2C1SCL: I ² C1 clock pin
		nRD	O	EBI read enable output pin	
10	7	5	PA.10	I/O	Digital GPIO pin
			I2C1SDA	I/O	I2C1SDA: I ² C1 data I/O pin
		nWR	O	EBI write enable output pin	
11	8	6	PA.9	I/O	Digital GPIO pin
			I2C0SCL	I/O	I2C0SCL: I ² C0 clock pin
12	9	7	PA.8	I/O	Digital GPIO pin
			I2C0SDA	I/O	I2C0SDA: I ² C0 data I/O pin
13			PD.8	I/O	Digital GPIO pin
			SPISS30	I/O	SPISS30: SPI3 slave select pin
14			PD.9	I/O	Digital GPIO pin
			SPICLK3	I/O	SPICLK3: SPI3 serial clock pin



Pin No.			Pin Name	Type	Description
LQFP 100-pin	LQFP 64-pin	LQFP 48-pin			
15			PD.10	I/O	Digital GPIO pin
			MISO30	I/O	MISO30: SPI3 MISO (Master In, Slave Out) pin
16			PD.11	I/O	Digital GPIO pin
			MOSI30	I/O	MOSI30: SPI3 MOSI (Master Out, Slave In) pin
17			PD.12	I/O	Digital GPIO pin
			MISO31	I/O	MISO31: SPI3 2 nd MISO (Master In, Slave Out) pin
18			PD.13	I/O	Digital GPIO pin
			MOSI31	I/O	MOSI31: SPI3 2 nd MOSI (Master Out, Slave In) pin
19	10	8	PB.4	I/O	Digital GPIO pin
			RXD1	I	RXD1: Data receiver input pin for UART1
20	11	9	PB.5	I/O	Digital GPIO pin
			TXD1	O	TXD1: Data transmitter output pin for UART1
21	12		PB.6	I/O	Digital GPIO pin
			RTS1	O	RTS1: Request to Send output pin for UART1
			ALE	O	EBI address latch enable output pin
22	13		PB.7	I/O	Digital GPIO pin
			CTS1	I	CTS1: Clear to Send input pin for UART1
			nCS	O	EBI chip select enable output pin
23	14	10	LDO	P	LDO output pin
24	15	11	V _{DD}	P	Power supply for I/O ports and LDO source for internal PLL and digital function
25	16	12	V _{SS}	P	Ground
26			PE.8	I/O	Digital GPIO pin
27			PE.7	I/O	Digital GPIO pin
28	17	13	V _{BUS}	USB	POWER SUPPLY: From USB Host or HUB.
29	18	14	V _{DD33}	USB	Internal Power Regulator Output 3.3 V Decoupling Pin
30	19	15	D-	USB	USB Differential Signal D-
31	20	16	D+	USB	USB Differential Signal D+
32	21	17	PB.0	I/O	Digital GPIO pin
			RXD0	I	RXD0: Data receiver input pin for UART0



Pin No.			Pin Name	Type	Description
LQFP 100-pin	LQFP 64-pin	LQFP 48-pin			
33	22	18	PB.1	I/O	Digital GPIO pin
			TXD0	O	TXD0: Data transmitter output pin for UART0
34	23		PB.2	I/O	Digital GPIO pin
			RTS0	O	RTS0: Request to Send output pin for UART0
			nWRL	O	EBI low byte write enable output pin
			T2EX	I	Timer2 external capture input pin
35	24		PB.3	I/O	Digital GPIO pin
			CTS0	I	CTS0: Clear to Send input pin for UART0
			nWRH	O	EBI high byte write enable output pin
			T3EX	I	Timer3 external capture input pin
36	25	19	PD.6	I/O	Digital GPIO pin
			CANRX0	I	CAN Bus0 RX Input
37	26	20	PD.7	I/O	Digital GPIO pin
			CANTX0	O	CAN Bus0 TX Output
38	27		PD.14	I/O	Digital GPIO pin
			RXD2	I	RXD2: Data receiver input pin for UART2
39	28		PD.15	I/O	Digital GPIO pin
			TXD2	O	TXD2: Data transmitter output pin for UART2
40			PC.5	I/O	Digital GPIO pin
			MOSI01	I/O	MOSI01: SPI0 2 nd MOSI (Master Out, Slave In) pin
41			PC.4	I/O	Digital GPIO pin
			MISO01	I/O	MISO01: SPI0 2 nd MISO (Master In, Slave Out) pin
42	29	21	PC.3	I/O	Digital GPIO pin
			MOSI00	I/O	MOSI00: SPI0 MOSI (Master Out, Slave In) pin
			I2SDO	O	I2SDO: I ² S data output
43	30	22	PC.2	I/O	Digital GPIO pin
			MISO00	I/O	MISO00: SPI0 MISO (Master In, Slave Out) pin
			I2SDI	I	I2SDI: I ² S data input
44	31	23	PC.1	I/O	Digital GPIO pin
			SPICLK0	I/O	SPICLK0: SPI0 serial clock pin



Pin No.			Pin Name	Type	Description
LQFP 100-pin	LQFP 64-pin	LQFP 48-pin			
			I2SBCLK	I/O	I2SBCLK: I ² S bit clock pin
45	32	24	PC.0	I/O	Digital GPIO pin
			SPISS00	I/O	SPISS00: SPI0 slave select pin
			I2SLRCLK	I/O	I2SLRCLK: I ² S left right channel clock
46			PE.6	I/O	Digital GPIO pin
47			PE.5	I/O	Digital GPIO pin
			PWM5	I/O	PWM5: PWM output/Capture input
			T1EX	I	Timer1 external capture input pin
48			PB.11	I/O	Digital GPIO pin
			TM3	I/O	TM3: Timer3 event counter input / toggle output
			PWM4	I/O	PWM4: PWM output/Capture input
49			PB.10	I/O	Digital GPIO pin
			TM2	I/O	TM2: Timer2 event counter input / toggle output
			SPISS01	I/O	SPISS01: SPI0 2 nd slave select pin
50			PB.9	I/O	Digital GPIO pin
			TM1	I/O	TM1: Timer1 event counter input / toggle output
			SPISS11	I/O	SPISS11: SPI1 2 nd slave select pin
51			PE.4	I/O	Digital GPIO pin
52			PE.3	I/O	Digital GPIO pin
53			PE.2	I/O	Digital GPIO pin
54			PE.1	I/O	Digital GPIO pin
			PWM7	I/O	PWM7: PWM output/Capture input
55			PE.0	I/O	Digital GPIO pin
			PWM6	I/O	PWM6: PWM output/Capture input
56			PC.13	I/O	Digital GPIO pin
			MOSI11	I/O	MOSI11: SPI1 2 nd MOSI (Master Out, Slave In) pin
57			PC.12	I/O	Digital GPIO pin
			MISO11	I/O	MISO11: SPI1 2 nd MISO (Master In, Slave Out) pin
58	33		PC.11	I/O	Digital GPIO pin



Pin No.			Pin Name	Type	Description
LQFP 100-pin	LQFP 64-pin	LQFP 48-pin			
			MOSI10	I/O	MOSI10: SPI1 MOSI (Master Out, Slave In) pin
59	34		PC.10	I/O	Digital GPIO pin
			MISO10	I/O	MISO10: SPI1 MISO (Master In, Slave Out) pin
60	35		PC.9	I/O	Digital GPIO pin
			SPICLK1	I/O	SPICLK1: SPI1 serial clock pin
61	36		PC.8	I/O	Digital GPIO pin
			SPISS10	I/O	SPISS10: SPI1 slave select pin
			MCLK	O	EBI clock output
62	37	25	PA.15	I/O	Digital GPIO pin
			PWM3	I/O	PWM3: PWM output/Capture input
			I2SMCLK	O	I2SMCLK: I ² S master clock output pin
63	38	26	PA.14	I/O	Digital GPIO pin
			PWM2	I/O	PWM2: PWM output/Capture input
			AD15	I/O	EBI Address/Data bus bit15
64	39	27	PA.13	I/O	Digital GPIO pin
			PWM1	I/O	PWM1: PWM output/Capture input
			AD14	I/O	EBI Address/Data bus bit14
65	40	28	PA.12	I/O	Digital GPIO pin
			PWM0	I/O	PWM0: PWM output/Capture input
			AD13	I/O	EBI Address/Data bus bit13
66	41	29	ICE_DAT	I/O	Serial Wired Debugger Data pin
67	42	30	ICE_CK	I	Serial Wired Debugger Clock pin
68			V _{DD}	P	Power supply for I/O ports and LDO source for internal PLL and digital circuit
69			V _{SS}	P	Ground
70	43	31	AV _{SS}	AP	Ground Pin for analog circuit
71	44	32	PA.0	I/O	Digital GPIO pin
			ADC0	AI	ADC0: ADC analog input
72	45	33	PA.1	I/O	Digital GPIO pin
			ADC1	AI	ADC1: ADC analog input



Pin No.			Pin Name	Type	Description
LQFP 100-pin	LQFP 64-pin	LQFP 48-pin			
			AD12	I/O	EBI Address/Data bus bit12
73	46	34	PA.2	I/O	Digital GPIO pin
			ADC2	AI	ADC2: ADC analog input
			AD11	I/O	EBI Address/Data bus bit11
74	47	35	PA.3	I/O	Digital GPIO pin
			ADC3	AI	ADC3: ADC analog input
			AD10	I/O	EBI Address/Data bus bit10
75	48	36	PA.4	I/O	Digital GPIO pin
			ADC4	AI	ADC4: ADC analog input
			AD9	I/O	EBI Address/Data bus bit9
76	49	37	PA.5	I/O	Digital GPIO pin
			ADC5	AI	ADC5: ADC analog input
			AD8	I/O	EBI Address/Data bus bit8
77	50	38	PA.6	I/O	Digital GPIO pin
			ADC6	AI	ADC6: ADC analog input
			AD7	I/O	EBI Address/Data bus bit7
78	51	39	PA.7	I/O	Digital GPIO pin
			ADC7	AI	ADC7: ADC analog input
			SPISS21	I/O	SPISS21: SPI2 2 nd slave select pin
			AD6	I/O	EBI Address/Data bus bit6
79			VREF	AP	Voltage reference input for ADC
80	52	40	AV _{DD}	AP	Power supply for internal analog circuit
81			PD.0	I/O	Digital GPIO pin
			SPISS20	I/O	SPISS20: SPI2 slave select pin
82			PD.1	I/O	Digital GPIO pin
			SPICLK2	I/O	SPICLK2: SPI2 serial clock pin
83			PD.2	I/O	Digital GPIO pin
			MISO20	I/O	MISO20: SPI2 MISO (Master In, Slave Out) pin
84			PD.3	I/O	Digital GPIO pin
			MOSI20	I/O	MOSI20: SPI2 MOSI (Master Out, Slave In) pin



Pin No.			Pin Name	Type	Description
LQFP 100-pin	LQFP 64-pin	LQFP 48-pin			
85			PD.4	I/O	Digital GPIO pin
			MISO21	I/O	MISO21: SPI2 2 nd MISO (Master In, Slave Out) pin
86			PD.5	I/O	Digital GPIO pin
			MOSI21	I/O	MOSI21: SPI2 2 nd MOSI (Master Out, Slave In) pin
87	53	41	PC.7	I/O	Digital GPIO pin
			CPN0	AI	CPN0: Comparator0 Negative input pin
			AD5	I/O	EBI Address/Data bus bit 5
88	54	42	PC.6	I/O	Digital GPIO pin
			CPP0	AI	CPP0: Comparator0 Positive input pin
			AD4	I/O	EBI Address/Data bus bit 4
89	55		PC.15	I/O	Digital GPIO pin
			CPN1	AI	CPN1: Comparator1 Negative input pin
			AD3	I/O	EBI Address/Data bus bit 3
90	56		PC.14	I/O	Digital GPIO pin
			CPP1	AI	CPP1: Comparator1 Positive input pin
			AD2	I/O	EBI Address/Data bus bit 2
91	57	43	PB.15	I/O	Digital GPIO pin
			/INT1	I	/INT1: External interrupt0 input pin
			T0EX	I	Timer 0 external capture input pin
92	58	44	XT1_OUT	O	External 4~24 MHz high speed crystal output pin
93	59	45	XT1_IN	I	External 4~24 MHz high speed crystal input pin
94	60	46	/RESET	I	External reset input: Low active, set this pin low reset chip to initial state. With internal pull-up.
95	61		V _{SS}	P	Ground
96	62		V _{DD}	P	Power supply for I/O ports and LDO source for internal PLL and digital circuit
97			PS2DAT	I/O	PS/2 Data pin
98			PS2CLK	I/O	PS/2 clock pin
99	63	47	PV _{SS}	P	PLL Ground
100	64	48	PB.8	I/O	Digital GPIO pin
			STADC	I	STADC: ADC external trigger input.



Pin No.			Pin Name	Type	Description
LQFP 100-pin	LQFP 64-pin	LQFP 48-pin			
			TM0	I/O	TM0: Timer0 event counter input / toggle output

Note: Pin Type: I = Digital Input, O = Digital Output; AI = Analog Input; P = Power Pin; AP = Analog Power



4 BLOCK DIAGRAM

4.1 NuMicro™ NUC130/NUC140 Block Diagram

4.1.1 NuMicro™ NUC130 Block Diagram

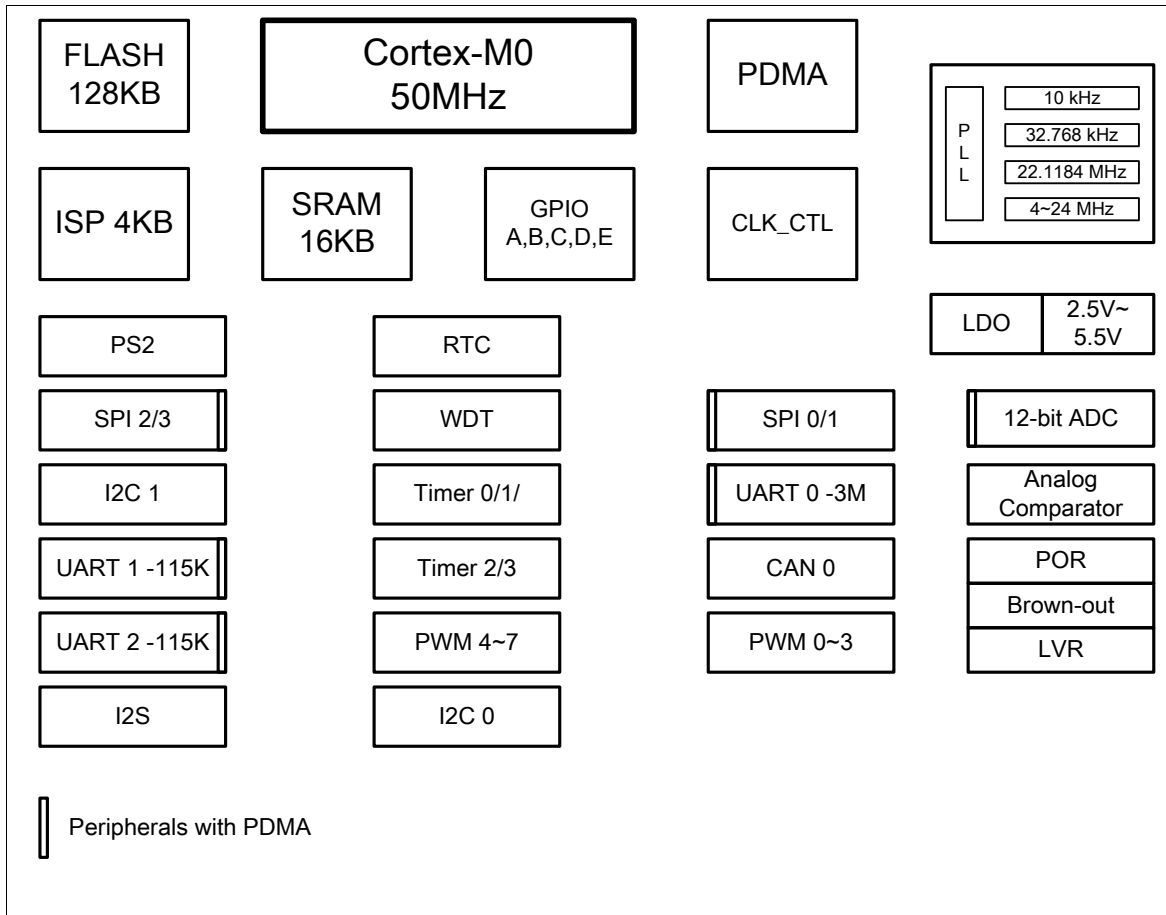

Figure 4-1 NuMicro™ NUC130 Block Diagram



4.1.2 NuMicro™ NUC140 Block Diagram

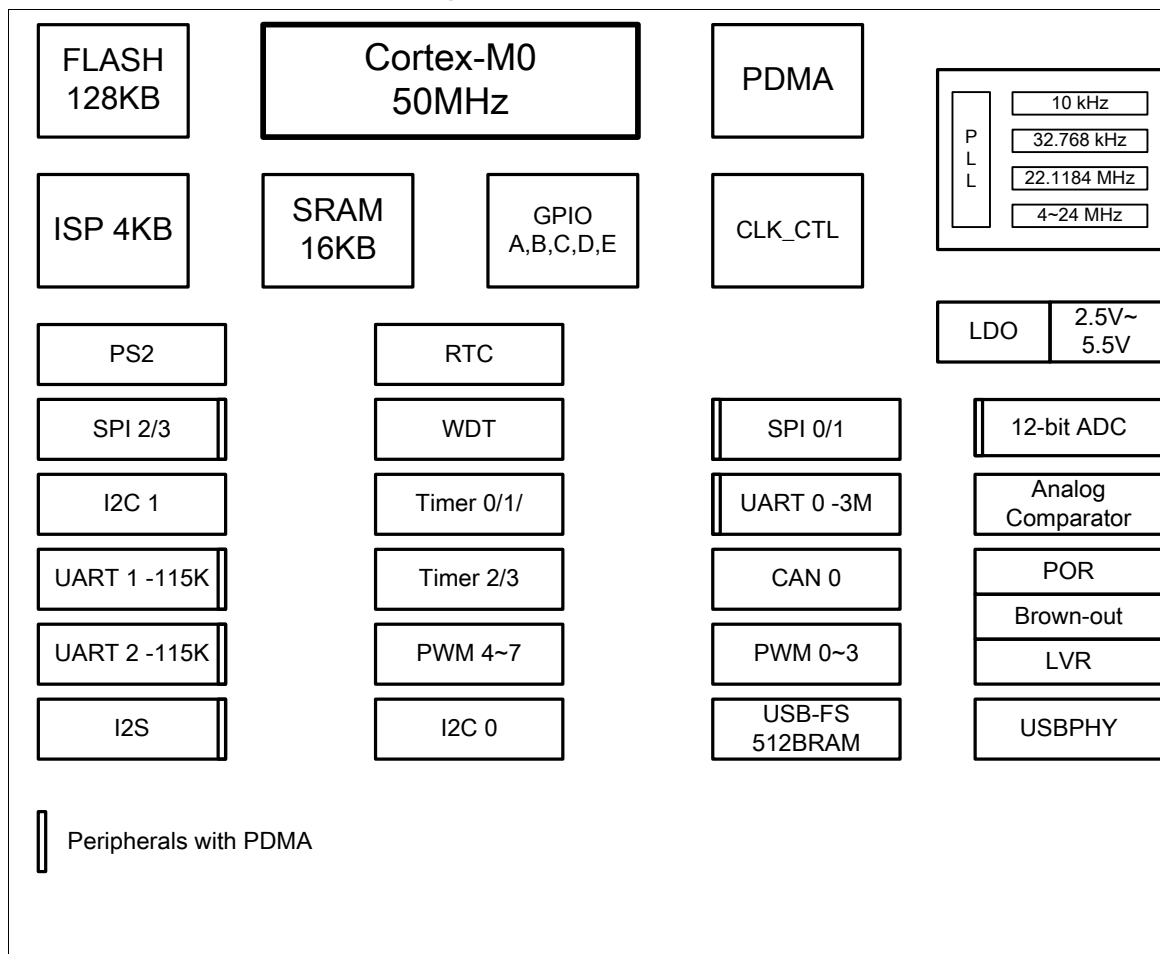

Figure 4-2 NuMicro™ NUC140 Block Diagram

5 FUNCTIONAL DESCRIPTION

5.1 ARM® Cortex™-M0 Core

The Cortex™-M0 processor is a configurable, multistage, 32-bit RISC processor. It has an AMBA AHB-Lite interface and includes an NVIC component. It also has optional hardware debug functionality. The processor can execute Thumb code and is compatible with other Cortex-M profile processor. The profile supports two modes - Thread mode and Handler mode. Handler mode is entered as a result of an exception. An exception return can only be issued in Handler mode. Thread mode is entered on Reset, and can be entered as a result of an exception return. Figure 5-1 shows the functional controller of processor.

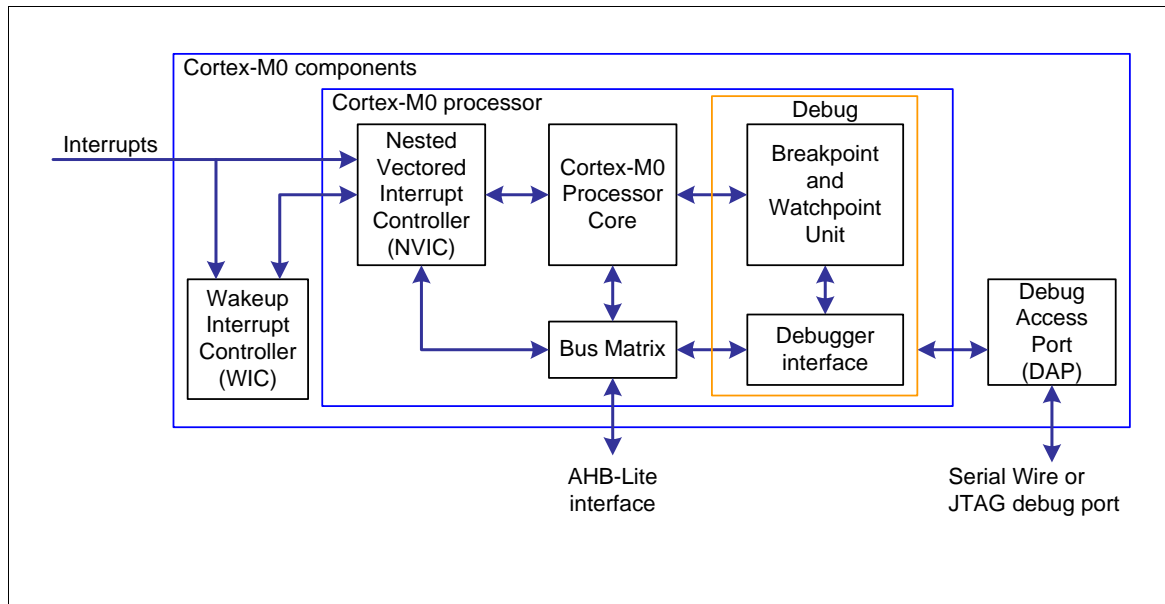

Figure 5-1 Functional Controller Diagram

The implemented device provides the following features:

- A low gate count processor:
 - ◆ ARMv6-M Thumb® instruction set
 - ◆ Thumb-2 technology
 - ◆ ARMv6-M compliant 24-bit SysTick timer
 - ◆ A 32-bit hardware multiplier
 - ◆ Supports little-endian data accesses
 - ◆ Capable of having deterministic, fixed-latency, interrupt handling
 - ◆ Load/store-multiples and multicycle-multiplies that can be abandoned and restarted to facilitate rapid interrupt handling
 - ◆ C Application Binary Interface compliant exception model. This is the ARMv6-M, C Application Binary Interface (C-ABI) compliant exception model that enables the use of pure C functions as interrupt handlers
 - ◆ Low power sleep mode entry using Wait For Interrupt (WFI), Wait For Event

(WFE) instructions, or the return from interrupt sleep-on-exit feature

- NVIC:
 - ◆ 32 external interrupt inputs, each with four levels of priority
 - ◆ Dedicated Non-Maskable Interrupt (NMI) input.
 - ◆ Supported for both level-sensitive and pulse-sensitive interrupt lines
 - ◆ Wake-up Interrupt Controller (WIC), providing ultra-low power sleep mode support
- Debug support:
 - ◆ Four hardware breakpoints
 - ◆ Two watchpoints
 - ◆ Program Counter Sampling Register (PCSR) for non-intrusive code profiling
 - ◆ Single step and vector catch capabilities
- Bus interfaces:
 - ◆ Single 32-bit AMBA-3 AHB-Lite system interface that provides simple integration to all system peripherals and memory
 - ◆ Single 32-bit slave port that supports DAP (Debug Access Port)



5.2 System Manager

5.2.1 Overview

This chapter includes the following sections:

- System Resets
- System Memory Map
- System management registers for Part Number ID, chip reset and on-chip controllers reset , multi-functional pin control
- System Timer (SysTick)
- Nested Vectored Interrupt Controller (NVIC)
- System Control registers

5.2.2 System Reset

The system reset can be issued by one of the below listed events. For these reset event flags can be read by RSTSRC register.

- Power-on Reset
- Low level on the /RESET pin
- Watchdog Time Out Reset
- Low Voltage Reset
- Brown-out Detector Reset
- CPU Reset
- System Reset

System Reset and Power-On Reset all reset the whole chip including all peripherals. The difference between System Reset and Power-On Reset is external crystal circuit and ISPCON.BS bit. System Reset does not reset external crystal circuit and ISPCON.BS bit, but Power-On Reset does.

5.2.3 System Power Distribution

In this chip, the power distribution is divided into three segments.

- Analog power from AV_{DD} and AV_{SS} provides the power for analog components operation.
- Digital power from V_{DD} and V_{SS} supplies the power to the internal regulator which provides a fixed 2.5 V power for digital operation and I/O pins.
- USB transceiver power from V_{BUS} offers the power for operating the USB transceiver. (For NuMicro™ NUC140 only)

The outputs of internal voltage regulators, LDO and V_{DD33} , require an external capacitor which should be located close to the corresponding pin. Analog power (AV_{DD}) should be the same voltage level of the digital power (V_{DD}). Figure 5-2 shows the power distribution of NuMicro™ NUC140 and Figure 5-3 shows the power distribution of NuMicro™ NUC130.

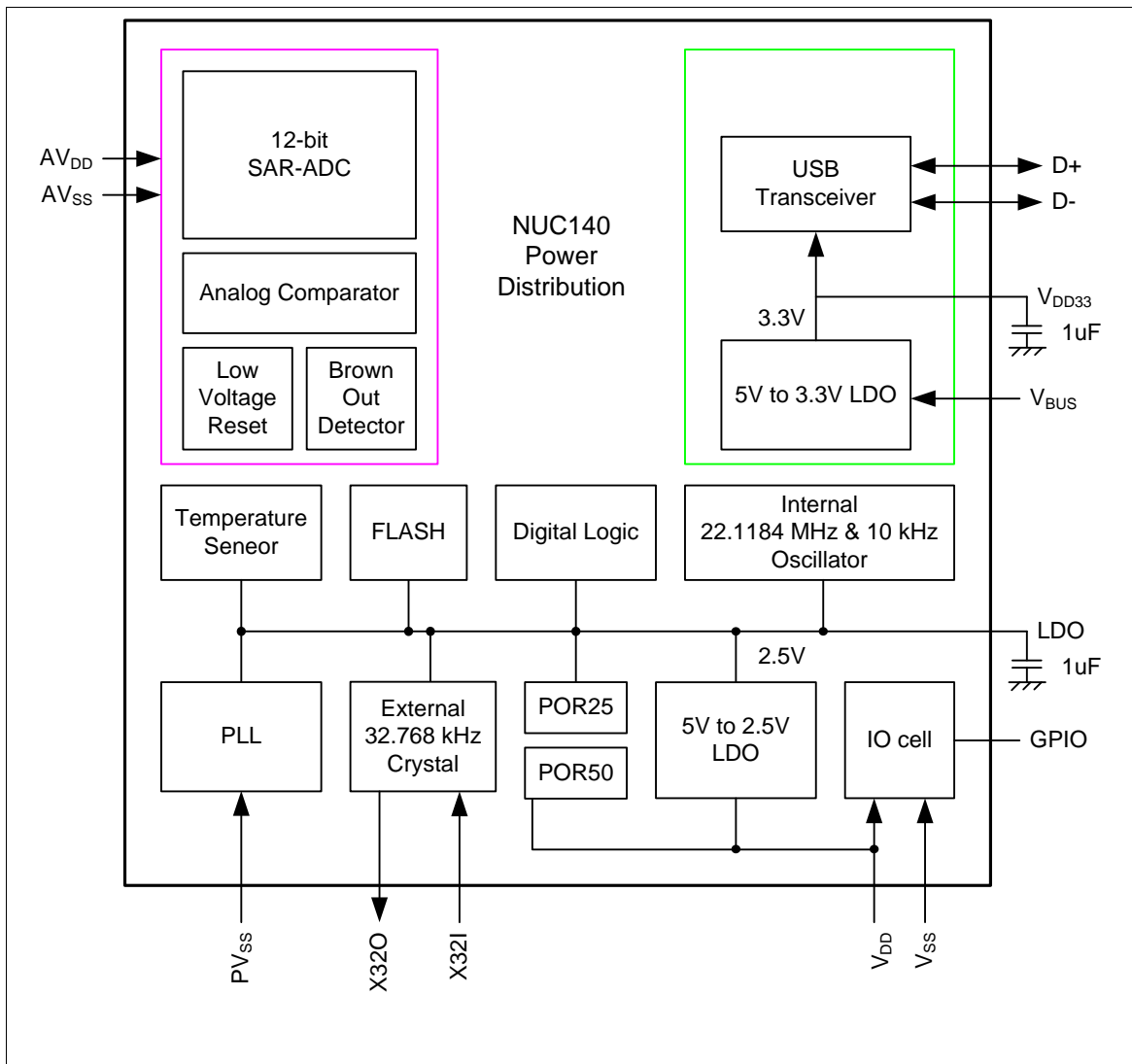

Figure 5-2 NuMicro™ NUC140 Power Distribution Diagram

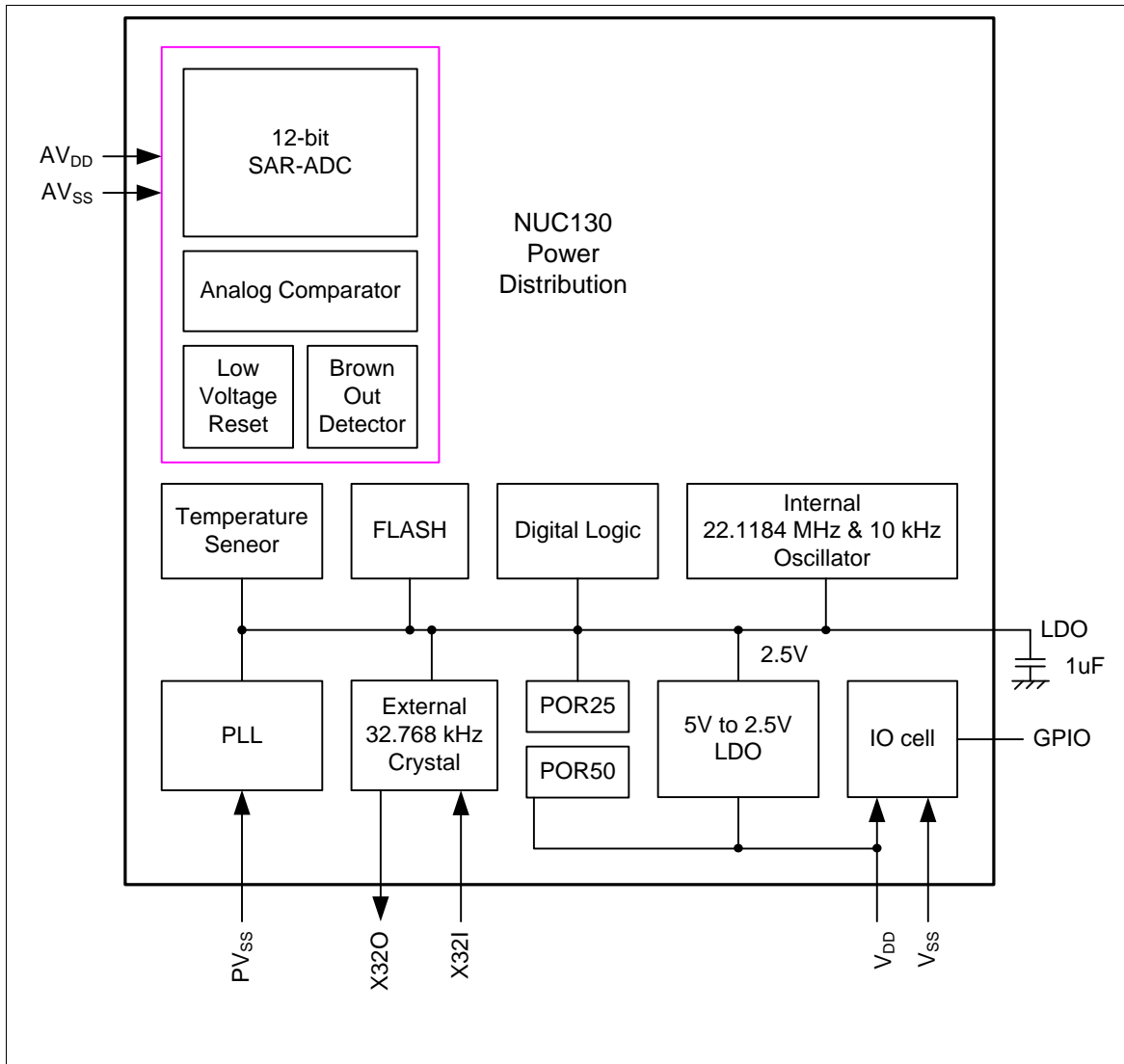

Figure 5-3 NuMicro™ NUC130 Power Distribution Diagram



5.2.4 System Memory Map

The NuMicro™ NUC100 Series provides 4G-byte addressing space. The memory locations assigned to each on-chip controllers are shown in the following table. The detailed register definition, memory space, and programming detailed will be described in the following sections for each on-chip peripherals. The NuMicro™ NUC100 Series only supports little-endian data format.

Address Space	Token	Controllers
Flash and SRAM Memory Space		
0x0000_0000 – 0x0001_FFFF	FLASH_BA	FLASH Memory Space (128KB)
0x2000_0000 – 0x2000_3FFF	SRAM_BA	SRAM Memory Space (16KB)
0x6000_0000 – 0x6001_FFFF	EXTMEM_BA	External Memory Space (128KB)
AHB Controllers Space (0x5000_0000 – 0x501F_FFFF)		
0x5000_0000 – 0x5000_01FF	GCR_BA	System Global Control Registers
0x5000_0200 – 0x5000_02FF	CLK_BA	Clock Control Registers
0x5000_0300 – 0x5000_03FF	INT_BA	Interrupt Multiplexer Control Registers
0x5000_4000 – 0x5000_7FFF	GPIO_BA	GPIO Control Registers
0x5000_8000 – 0x5000_BFFF	PDMA_BA	Peripheral DMA Control Registers
0x5000_C000 – 0x5000_FFFF	FMC_BA	Flash Memory Control Registers
0x5001_0000 – 0x5001_03FF	EBI_BA	External Bus Interface Control Registers
APB1 Controllers Space (0x4000_0000 ~ 0x400F_FFFF)		
0x4000_4000 – 0x4000_7FFF	WDT_BA	Watchdog Timer Control Registers
0x4000_8000 – 0x4000_BFFF	RTC_BA	Real Time Clock (RTC) Control Register
0x4001_0000 – 0x4001_3FFF	TMR01_BA	Timer0/Timer1 Control Registers
0x4002_0000 – 0x4002_3FFF	I2C0_BA	I ² C0 Interface Control Registers
0x4003_0000 – 0x4003_3FFF	SPIO_BA	SPIO with master/slave function Control Registers
0x4003_4000 – 0x4003_7FFF	SPI1_BA	SPI1 with master/slave function Control Registers
0x4004_0000 – 0x4004_3FFF	PWMA_BA	PWM0/1/2/3 Control Registers
0x4005_0000 – 0x4005_3FFF	UART0_BA	UART0 Control Registers
0x4006_0000 – 0x4006_3FFF	USBD_BA	USB 2.0 FS device Controller Registers
0x400D_0000 – 0x400D_3FFF	ACMP_BA	Analog Comparator Control Registers



0x400E_0000 – 0x400E_FFFF	ADC_BA	Analog-Digital-Converter (ADC) Control Registers
APB2 Controllers Space (0x4010_0000 ~ 0x401F_FFFF)		
0x4010_0000 – 0x4010_3FFF	PS2_BA	PS/2 Interface Control Registers
0x4011_0000 – 0x4011_3FFF	TMR23_BA	Timer2/Timer3 Control Registers
0x4012_0000 – 0x4012_3FFF	I2C1_BA	I ² C1 Interface Control Registers
0x4013_0000 – 0x4013_3FFF	SPI2_BA	SPI2 with master/slave function Control Registers
0x4013_4000 – 0x4013_7FFF	SPI3_BA	SPI3 with master/slave function Control Registers
0x4014_0000 – 0x4014_3FFF	PWMB_BA	PWM4/5/6/7 Control Registers
0x4015_0000 – 0x4015_3FFF	UART1_BA	UART1 Control Registers
0x4015_4000 – 0x4015_7FFF	UART2_BA	UART2 Control Registers
0x4018_0000 – 0x4018_3FFF	CAN0_BA	CAN0 Bus Control Registers
0x401A_0000 – 0x401A_3FFF	I2S_BA	I ² S Interface Control Registers
System Controllers Space (0xE000_E000 ~ 0xE000_EFFF)		
0xE000_E010 – 0xE000_E0FF	SCS_BA	System Timer Control Registers
0xE000_E100 – 0xE000_ECFF	SCS_BA	External Interrupt Controller Control Registers
0xE000_ED00 – 0xE000_ED8F	SCS_BA	System Control Registers

Table 5-1 Address Space Assignments for On-Chip Controllers



5.2.5 System Manager Control Registers

R: read only, W: write only, R/W: both read and write

Register	Offset	R/W	Description	Reset Value
GCR Base Address:				
GCR_BA = 0x5000_0000				
PDID	GCR_BA+0x00	R	Part Device Identification Number Register	0x0014_0018 ^[1]
RSTSRC	GCR_BA+0x04	R/W	System Reset Source Register	0x0000_00XX
IPRSTC1	GCR_BA+0x08	R/W	IP Reset Control Register1	0x0000_0000
IPRSTC2	GCR_BA+0x0C	R/W	IP Reset Control Register2	0x0000_0000
BODCR	GCR_BA+0x18	R/W	Brown-out Detector Control Register	0x0000_008X
TEMPCR	GCR_BA+0x1C	R/W	Temperature Sensor Control Register	0x0000_0000
PORCR	GCR_BA+0x24	R/W	Power-On-Reset Controller Register	0x0000_00XX
GPA_MFP	GCR_BA+0x30	R/W	GPIOA Multiple Function and Input Type Control Register	0x0000_0000
GPB_MFP	GCR_BA+0x34	R/W	GPIOB Multiple Function and Input Type Control Register	0x0000_0000
GPC_MFP	GCR_BA+0x38	R/W	GPIOC Multiple Function and Input Type Control Register	0x0000_0000
GPD_MFP	GCR_BA+0x3C	R/W	GPIOD Multiple Function and Input Type Control Register	0x0000_0000
GPE_MFP	GCR_BA+0x40	R/W	GPIOE Multiple Function and Input Type Control Register	0x0000_0000
ALT_MFP	GCR_BA+0x50	R/W	Alternative Multiple Function Pin Control Register	0x0000_0000
REGWRPROT	GCR_BA+0x100	R/W	Register Write Protect register	0x0000_0000

Note: [1] Depends on part number.



Part Device ID Code Register (PDID)

Register	Offset	R/W	Description	Reset Value
PDID	GCR_BA+0x00	R	Part Device Identification Number Register	0x0014_0018 ^[1]

[1] Each part number has a unique default reset value.

31	30	29	28	27	26	25	24
PDID[31:24]							
23	22	21	20	19	18	17	16
PDID[23:16]							
15	14	13	12	11	10	9	8
PDID[15:8]							
7	6	5	4	3	2	1	0
PDID[7:0]							

Bits	Description
[31:0]	<p>PDID</p> <p>Part Device Identification Number</p> <p>This register reflects device part number code. SW can read this register to identify which device is used.</p>

NuMicro NUC130/NUC140™ Series	Part Device Identification Number
NUC130LC1CN	0x20013008
NUC130LD2CN	0x20013004
NUC130LE3CN	0x20013000
NUC130RC1CN	0x20013017
NUC130RD2CN	0x20013013
NUC130RE3CN	0x20013009
NUC130VE3CN	0x20013018
NUC140LC1CN	0x20014008
NUC140LD2CN	0x20014004
NUC140LE3CN	0x20014000
NUC140RC1CN	0x20014017
NUC140RD2CN	0x20014013
NUC140RE3CN	0x20014009
NUC140VE3CN	0x20014018



System Reset Source Register (RSTSRC)

This register provides specific information for software to identify this chip's reset source from last operation.

Register	Offset	R/W	Description	Reset Value
RSTSRC	GCR_BA+0x04	R/W	System Reset Source Register	0x0000_00XX

31	30	29	28	27	26	25	24
Reserved							
23	22	21	20	19	18	17	16
Reserved							
15	14	13	12	11	10	9	8
Reserved							
7	6	5	4	3	2	1	0
RSTS_CPU	Reserved	RSTS_SYS	RSTS_BOD	RSTS_LVR	RSTS_WDT	RSTS_RESE T	RSTS_POR

Bits	Description
[31:8]	Reserved Reserved
[7]	RSTS_CPU The RSTS_CPU flag is set by hardware if software writes CPU_RST (IPRSTC1[1]) 1 to reset Cortex-M0 CPU kernel and Flash memory controller (FMC). 1 = The Cortex-M0 CPU kernel and FMC are reset by software setting CPU_RST to 1. 0 = No reset from CPU Software can write 1 to clear this bit to 0.
[6]	Reserved Reserved
[5]	RSTS_SYS The RSTS_SYS flag is set by the "reset signal" from the Cortex_M0 kernel to indicate the previous reset source. 1 = The Cortex_M0 had issued the reset signal to reset the system by software writing 1 to bit SYSRESETREQ(AIRC[R2], Application Interrupt and Reset Control Register, address = 0xE000ED0C) in system control registers of Cortex_M0 kernel. 0 = No reset from Cortex_M0 Software can write 1 to clear this bit to 0.
[4]	RSTS_BOD The RSTS_BOD flag is set by the "reset signal" from the Brown-out-Detector to indicate the previous reset source. 1 = The BOD had issued the reset signal to reset the system 0 = No reset from BOD Software can write 1 to clear this bit to 0.
[3]	RSTS_LVR The RSTS_LVR flag is set by the "reset signal" from the Low-Voltage-Reset controller to indicate the previous reset source. 1 = The LVR controller had issued the reset signal to reset the system.



		<p>0 = No reset from LVR</p> <p>Software can write 1 to clear this bit to 0.</p>
[2]	RSTS_WDT	<p>The RSTS_WDT flag is set by the “reset signal” from the watchdog timer to indicate the previous reset source.</p> <p>1 = The watchdog timer had issued the reset signal to reset the system.</p> <p>0 = No reset from watchdog timer</p> <p>Software can write 1 to clear this bit to 0.</p>
[1]	RSTS_RESET	<p>The RSTS_RESET flag is set by the “reset signal” from the /RESET pin to indicate the previous reset source.</p> <p>1 = The Pin /RESET had issued the reset signal to reset the system.</p> <p>0 = No reset from /RESET pin</p> <p>Software can write 1 to clear this bit to 0.</p>
[0]	RSTS_POR	<p>The RSTS_POR flag is set by the “reset signal” from the Power-On Reset (POR) controller or bit CHIP_RST (IPRSTC1[0]) to indicate the previous reset source.</p> <p>1 = The Power-On Reset (POR) or CHIP_RST had issued the reset signal to reset the system.</p> <p>0 = No reset from POR or CHIP_RST</p> <p>Software can write 1 to clear this bit to 0.</p>



Peripheral Reset Control Register1 (IPRSTC1)

Register	Offset	R/W	Description	Reset Value
IPRSTC1	GCR_BA+0x08	R/W	IP Reset Control Register1	0x0000_0000

31	30	29	28	27	26	25	24
Reserved							
23	22	21	20	19	18	17	16
Reserved							
15	14	13	12	11	10	9	8
Reserved							
7	6	5	4	3	2	1	0
Reserved				EBI_RST	PDMA_RST	CPU_RST	CHIP_RST

Bits	Description
[31:4]	Reserved Reserved
[3]	<p>EBI_RST</p> <p>EBI Controller Reset (write-protection bit in NUC130/NUC140 100-pin and 64-pin package)</p> <p>Set this bit to 1 will generate a reset signal to the EBI. User need to set this bit to 0 to release from the reset state.</p> <p>This bit is the protected bit, It means programming this bit needs to write "59h", "16h", "88h" to address 0x5000_0100 to disable register protection. Refer to the register REGWRPROT at address GCR_BA+0x100</p> <p>1 = EBI controller reset 0 = EBI controller normal operation</p>
[2]	<p>PDMA_RST</p> <p>PDMA Controller Reset (write-protection bit in NUC130/NUC140)</p> <p>Setting this bit to 1 will generate a reset signal to the PDMA. User need to set this bit to 0 to release from reset state.</p> <p>This bit is the protected bit, It means programming this bit needs to write "59h", "16h", "88h" to address 0x5000_0100 to disable register protection. Refer to the register REGWRPROT at address GCR_BA+0x100.</p> <p>1 = PDMA controller reset 0 = PDMA controller normal operation</p>
[1]	<p>CPU_RST</p> <p>CPU kernel one shot reset (Write-protection Bit)</p> <p>Setting this bit will only reset the CPU kernel and Flash Memory Controller(FMC), and this bit will automatically return to 0 after the 2 clock cycles</p> <p>This bit is the protected bit, It means programming this bit needs to write "59h", "16h", "88h" to address 0x5000_0100 to disable register protection. Refer to the register REGWRPROT at address GCR_BA+0x100</p> <p>1 = CPU one shot reset 0 = CPU normal operation</p>
[0]	<p>CHIP_RST</p> <p>CHIP one shot reset (Write-protection Bit)</p>



		<p>Setting this bit will reset the whole chip, including CPU kernel and all peripherals, and this bit will automatically return to 0 after the 2 clock cycles.</p> <p>The CHIP_RST is same as the POR reset, all the chip controllers is reset and the chip setting from flash are also reload.</p> <p>About the difference between CHIP_RST and SYSRESETREQ, please refer to section 5.2.2</p> <p>This bit is the protected bit. It means programming this bit needs to write "59h", "16h", "88h" to address 0x5000_0100 to disable register protection. Refer to the register REGWRPROT at address GCR_BA+0x100</p> <p>1 = CHIP one shot reset 0 = CHIP normal operation</p>
--	--	--



Peripheral Reset Control Register2 (IPRSTC2)

Setting these bits 1 will generate asynchronous reset signals to the corresponding IP controller. Users need to set these bits to 0 to release corresponding IP controller from reset state

Register	Offset	R/W	Description	Reset Value
IPRSTC2	GCR_BA+0x0C	R/W	IP Reset Control Register2	0x0000_0000

31	30	29	28	27	26	25	24
Reserved		I2S_RST	ADC_RST	USB_D_RST	Reserved		CAN0_RST
23	22	21	20	19	18	17	16
PS2_RST	ACMP_RST	PWM47_RST	PWM03_RST	Reserved	UART2_RST	UART1_RST	UART0_RST
15	14	13	12	11	10	9	8
SPI3_RST	SPI2_RST	SPI1_RST	SPI0_RST	Reserved		I2C1_RST	I2C0_RST
7	6	5	4	3	2	1	0
Reserved		TMR3_RST	TMR2_RST	TMR1_RST	TMR0_RST	GPIO_RST	Reserved

Bits	Description	
[31:30]	Reserved	Reserved
[29]	I2S_RST	I²S Controller Reset 1 = I ² S controller reset 0 = I ² S controller normal operation
[28]	ADC_RST	ADC Controller Reset 1 = ADC controller reset 0 = ADC controller normal operation
[27]	USB_D_RST	USB Device Controller Reset 1 = USB device controller reset 0 = USB device controller normal operation
[26:25]	Reserved	Reserved
[24]	CAN0_RST	CAN0 Controller Reset 1 = CAN0 controller reset 0 = CAN0 controller normal operation
[23]	PS2_RST	PS/2 Controller Reset 1 = PS/2 controller reset 0 = PS/2 controller normal operation
[22]	ACMP_RST	Analog Comparator Controller Reset 1 = Analog Comparator controller reset 0 = Analog Comparator controller normal operation



[21]	PWM47_RST	PWM47 controller Reset 1 = PWM47 controller reset 0 = PWM47 controller normal operation
[20]	PWM03_RST	PWM03 controller Reset 1 = PWM03 controller reset 0 = PWM03 controller normal operation
[19]	Reserved	Reserved
[18]	UART2_RST	UART2 controller Reset 1 = UART2 controller reset 0 = UART2 controller normal operation
[17]	UART1_RST	UART1 controller Reset 1 = UART1 controller reset 0 = UART1 controller normal operation
[16]	UART0_RST	UART0 controller Reset 1 = UART0 controller reset 0 = UART0 controller normal operation
[15]	SPI3_RST	SPI3 controller Reset 1 = SPI3 controller reset 0 = SPI3 controller normal operation
[14]	SPI2_RST	SPI2 controller Reset 1 = SPI2 controller reset 0 = SPI2 controller normal operation
[13]	SPI1_RST	SPI1 controller Reset 1 = SPI1 controller reset 0 = SPI1 controller normal operation
[12]	SPI0_RST	SPI0 controller Reset 1 = SPI0 controller reset 0 = SPI0 controller normal operation
[11:10]	Reserved	Reserved
[9]	I2C1_RST	I²C1 controller Reset 1 = I ² C1 controller reset 0 = I ² C1 controller normal operation
[8]	I2C0_RST	I²C0 controller Reset 1 = I ² C0 controller reset 0 = I ² C0 controller normal operation
[7:6]	Reserved	Reserved
[5]	TMR3_RST	Timer3 controller Reset 1 = Timer3 controller reset



		0 = Timer3 controller normal operation
[4]	TMR2_RST	Timer2 controller Reset 1 = Timer2 controller reset 0 = Timer2 controller normal operation
[3]	TMR1_RST	Timer1 controller Reset 1 = Timer1 controller reset 0 = Timer1 controller normal operation
[2]	TMR0_RST	Timer0 controller Reset 1 = Timer0 controller reset 0 = Timer0 controller normal operation
[1]	GPIO_RST	GPIO controller Reset 1 = GPIO controller reset 0 = GPIO controller normal operation
[0]	Reserved	Reserved



Brown-out Detector Control Register (BODCR)

Partial of the BODCR control registers values are initiated by the flash configuration and partial bits are write-protected bit. Programming write-protected bits needs to write “59h”, “16h”, “88h” to address 0x5000_0100 to disable register protection. Refer to the register REGWRPROT at address GCR_BA+0x100

Register	Offset	R/W	Description	Reset Value
BODCR	GCR_BA+0x18	R/W	Brown-out Detector Control Register	0x0000_008X

31	30	29	28	27	26	25	24
Reserved							
23	22	21	20	19	18	17	16
Reserved							
15	14	13	12	11	10	9	8
Reserved							
7	6	5	4	3	2	1	0
LVR_EN	BOD_OUT	BOD_LPM	BOD_INTF	BOD_RSTEN	BOD_VL		BOD_EN

Bits	Description	
[31:8]	Reserved	Reserved
[7]	LVR_EN	<p>Low Voltage Reset Enable (Write-protection Bit)</p> <p>The LVR function reset the chip when the input power voltage is lower than LVR circuit setting. LVR function is enabled by default.</p> <p>1 = Low Voltage Reset function Enabled. After enabling the bit, the LVR function will be active with 100uS delay for LVR output stable (Default).</p> <p>0 = Low Voltage Reset function Disabled</p> <p>This bit is the protected bit. It means programming this needs to write “59h”, “16h”, “88h” to address 0x5000_0100 to disable register protection. Refer to the register REGWRPROT at address GCR_BA+0x100</p>
[6]	BOD_OUT	<p>Brown-out Detector Output Status</p> <p>1 = Brown-out Detector output status is 1. It means the detected voltage is lower than BOD_VL setting. If the BOD_EN is 0, BOD function disabled, this bit always responds 0</p> <p>0 = Brown-out Detector output status is 0. It means the detected voltage is higher than BOD_VL setting or BOD_EN is 0</p>
[5]	BOD_LPM	<p>Brown-out Detector Low Power Mode (Write-protection Bit)</p> <p>1 = BOD low power mode Enabled</p> <p>0 = BOD operated in Normal mode (default)</p> <p>The BOD consumes about 100 uA in normal mode, the low power mode can reduce the current to about 1/10 but slow the BOD response.</p> <p>This bit is the protected bit. It means programming this needs to write “59h”, “16h”, “88h” to address 0x5000_0100 to disable register protection. Refer to the register REGWRPROT at address GCR_BA+0x100.</p>



[4]	BOD_INTF	<p>Brown-out Detector Interrupt Flag</p> <p>1 = When Brown-out Detector detects the V_{DD} is dropped down through the voltage of BOD_VL setting or the V_{DD} is raised up through the voltage of BOD_VL setting, this bit is set to 1 and the Brown-out interrupt is requested if Brown-out interrupt is enabled.</p> <p>0 = Brown-out Detector does not detect any voltage draft at V_{DD} down through or up through the voltage of BOD_VL setting.</p> <p>Software can write 1 to clear this bit to 0.</p>															
[3]	BOD_RSTEN	<p>Brown-out Reset Enable (Write-protection Bit)</p> <p>1 = Brown-out “RESET” function Enabled</p> <p>While the Brown-out Detector function is enabled (BOD_EN high) and BOD reset function is enabled (BOD_RSTEN high), BOD will assert a signal to reset chip when the detected voltage is lower than the threshold (BOD_OUT high).</p> <p>0 = Brown-out “INTERRUPT” function Enable</p> <p>While the BOD function is enabled (BOD_EN high) and BOD interrupt function is enabled (BOD_RSTEN low), BOD will assert an interrupt if BOD_OUT is high. BOD interrupt will keep till to the BOD_EN set to 0. BOD interrupt can be blocked by disabling the NVIC BOD interrupt or disabling BOD function (set BOD_EN low).</p> <p>The default value is set by flash controller user configuration register config0 bit[20].</p> <p>This bit is the protected bit. It means programming this needs to write “59h”, “16h”, “88h” to address 0x5000_0100 to disable register protection. Refer to the register REGWRPROT at address GCR_BA+0x100.</p>															
[2:1]	BOD_VL	<p>Brown-out Detector Threshold Voltage Selection (Write-protection Bits)</p> <p>The default value is set by flash controller user configuration register config0 bit[22:21]</p> <p>This bit is the protected bit. It means programming this needs to write “59h”, “16h”, “88h” to address 0x5000_0100 to disable register protection. Refer to the register REGWRPROT at address GCR_BA+0x100.</p> <table border="1" style="width: 100%; border-collapse: collapse; margin-top: 10px;"> <thead> <tr> <th style="text-align: center;">BOV_VL[1]</th> <th style="text-align: center;">BOV_VL[0]</th> <th style="text-align: center;">Brown-out Voltage</th> </tr> </thead> <tbody> <tr> <td style="text-align: center;">1</td> <td style="text-align: center;">1</td> <td style="text-align: center;">4.5 V</td> </tr> <tr> <td style="text-align: center;">1</td> <td style="text-align: center;">0</td> <td style="text-align: center;">3.8 V</td> </tr> <tr> <td style="text-align: center;">0</td> <td style="text-align: center;">1</td> <td style="text-align: center;">2.7 V</td> </tr> <tr> <td style="text-align: center;">0</td> <td style="text-align: center;">0</td> <td style="text-align: center;">2.2 V</td> </tr> </tbody> </table>	BOV_VL[1]	BOV_VL[0]	Brown-out Voltage	1	1	4.5 V	1	0	3.8 V	0	1	2.7 V	0	0	2.2 V
BOV_VL[1]	BOV_VL[0]	Brown-out Voltage															
1	1	4.5 V															
1	0	3.8 V															
0	1	2.7 V															
0	0	2.2 V															
[0]	BOD_EN	<p>Brown-out Detector Enable (Write-protection Bit)</p> <p>The default value is set by flash controller user configuration register config0 bit[23]</p> <p>1 = Brown-out Detector function Enabled</p> <p>0 = Brown-out Detector function Disabled</p> <p>This bit is the protected bit. It means programming this needs to write “59h”, “16h”, “88h” to address 0x5000_0100 to disable register protection. Refer to the register REGWRPROT at address GCR_BA+0x100.</p>															



Temperature Sensor Control Register (TEMPCR)

Register	Offset	R/W	Description	Reset Value
TEMPCR	GCR_BA+0x1C	R/W	Temperature Sensor Control Register	0x0000_0000

31	30	29	28	27	26	25	24
Reserved							
23	22	21	20	19	18	17	16
Reserved							
15	14	13	12	11	10	9	8
Reserved							
7	6	5	4	3	2	1	0
Reserved							VTEMP_EN

Bits	Description
[31:1]	Reserved
[0]	<p>VTEMP_EN</p> <p>Temperature sensor Enable This bit is used to enable/disable temperature sensor function. 1 = Temperature sensor function Enabled. 0 = Temperature sensor function Disabled (Default).</p> <p>After this bit is set to 1, the value of temperature can get from ADC conversion result by ADC channel selecting channel 7 and alternative multiplexer channel selecting temperature sensor. Detail ADC conversion function. Please refer to ADC function chapter.</p>



Power-On-Reset Control Register (PORCR)

Register	Offset	R/W	Description	Reset Value
PORCR	GCR_BA+0x24	R/W	Power-On-Reset Controller Register	0x0000_00XX

31	30	29	28	27	26	25	24
Reserved							
23	22	21	20	19	18	17	16
Reserved							
15	14	13	12	11	10	9	8
POR_DIS_CODE[15:8]							
7	6	5	4	3	2	1	0
POR_DIS_CODE[7:0]							

Bits	Description	
[31:16]	Reserved	Reserved
[15:0]	POR_DIS_CODE	<p>Power-on-Reset Enable Control (Write-protection Bits)</p> <p>When powered on, the POR circuit generates a reset signal to reset the whole chip function, but noise on the power may cause the POR active again. User can disable internal POR circuit to avoid unpredictable noise to cause chip reset by writing 0x5AA5 to this field.</p> <p>The POR function will be active again when this field is set to another value or chip is reset by other reset source, including: /RESET, Watchdog, LVR reset, BOD reset, ICE reset command and the software-chip reset function</p> <p>This bit is the protected bit. It means programming this needs to write "59h", "16h", "88h" to address 0x5000_0100 to disable register protection. Refer to the register REGWRPROT at address GCR_BA+0x100.</p>



Multiple Function Pin GPIOA Control Register (GPA_MFP)

Register	Offset	R/W	Description	Reset Value
GPA_MFP	GCR_BA+0x30	R/W	GPIOA Multiple Function and Input Type Control Register	0x0000_0000

31	30	29	28	27	26	25	24
GPA_TYPE[15:8]							
23	22	21	20	19	18	17	16
GPA_TYPE[7:0]							
15	14	13	12	11	10	9	8
GPA_MFP[15:8]							
7	6	5	4	3	2	1	0
GPA_MFP[7:0]							

Bits	Description				
[31:16]	GPA_TYPEn 1 = GPIOA[15:0] I/O input Schmitt Trigger function Enabled. 0 = GPIOA[15:0] I/O input Schmitt Trigger function Disabled.				
[15]	GPA_MFP15	PA.15 Pin Function Selection The pin function depends on GPA_MFP15 and PA15_I2SMCLK (ALT_MFP[9]).			
		PA15_I2SMCLK	GPA_MFP[15]	PA.15 Function	
		0	0	GPIO	
		0	1	PWM3 (PWM)	
1	1	I2SMCLK (I ² S)			
[14]	GPA_MFP14	PA.14 Pin Function Selection The pin function depends on GPA_MFP14 and EBI_HB_EN[7] (ALT_MFP[23]) and EBI_EN (ALT_MFP[11]).			
		EBI_HB_EN[7]	EBI_EN	GPA_MFP[14]	PA.14 Function
		0	0	0	GPIO
		0	0	1	PWM2 (PWM)
1	1	1	AD15 (EBI AD bus bit 15)		
[13]	GPA_MFP13	PA.13 Pin Function Selection The pin function depends on GPA_MFP13 and EBI_HB_EN[6] (ALT_MFP[22]) and EBI_EN (ALT_MFP[11]).			
		EBI_HB_EN[6]	EBI_EN	GPA_MFP[13]	PA.13 Function
		0	0	0	GPIO
		0	0	1	PWM1 (PWM)



		1	1	1	AD14 (EBI AD bus bit 14)
[12]	GPA_MFP12	PA.12 Pin Function Selection			
		The pin function depends on GPA_MFP12 and EBI_HB_EN[5] (ALT_MFP[21]) and EBI_EN (ALT_MFP[11]).			
		EBI_HB_EN[5]	EBI_EN	GPA_MFP[12]	PA.12 Function
		0	0	0	GPIO
		0	0	1	PWM0 (PWM)
		1	1	1	AD13 (EBI AD bus bit 13)
[11]	GPA_MFP11	PA.11 Pin Function Selection			
		The pin function depends on GPA_MFP11 and EBI_EN (ALT_MFP[11]).			
		EBI_EN	GPA_MFP[11]	PA.11 Function	
		0	0	GPIO	
		0	1	SCL1 (I ² C)	
		1	1	nRD (EBI)	
[10]	GPA_MFP10	PA.10 Pin Function Selection			
		The pin function depends on GPA_MFP10 and EBI_EN (ALT_MFP[11]).			
		EBI_EN	GPA_MFP[10]	PA.10 Function	
		0	0	GPIO	
		0	1	SDA1 (I ² C)	
		1	1	nWR (EBI)	
[9]	GPA_MFP9	PA.9 Pin Function Selection			
		1 = The I ² C0 SCL function is selected to the pin PA.9			
		0 = The GPIOA[9] is selected to the pin PA.9			
[8]	GPA_MFP8	PA.8 Pin Function Selection			
		1 = The I ² C0 SDA function is selected to the pin PA.8			
		0 = The GPIOA[8] is selected to the pin PA.8			
[7]	GPA_MFP7	PA.7 Pin Function Selection			
		The pin function depends on GPA_MFP7 and PA7_S21 (ALT_MFP[2]) and EBI_EN (ALT_MFP[11]).			
		EBI_EN	PA7_S21	GPA_MFP[7]	PA.7 Function
		0	0	0	GPIO
		0	0	1	ADC7 (ADC)
		0	1	SPISS21 (SPI2)	
		1	0	1	AD6 (EBI AD bus bit 6)
[6]	GPA_MFP6	PA.6 Pin Function Selection			
		The pin function depends on GPA_MFP6 and EBI_EN (ALT_MFP[11]).			
		EBI_EN	GPA_MFP[6]	PA.6 Function	



		0	0	GPIO	
		0	1	ADC6 (ADC)	
		1	1	AD7 (EBI AD bus bit 7)	
[5]	GPA_MFP5	PA.5 Pin Function Selection The pin function depends on GPA_MFP5 and EBI_HB_EN[0] (ALT_MFP[16]) and EBI_EN (ALT_MFP[11]).			
		EBI_HB_EN[0]	EBI_EN	GPA_MFP[5]	PA.5 function
		0	0	0	GPIO
		0	0	1	ADC5 (ADC)
		1	1	1	AD8 (EBI AD bus bit 8)
[4]	GPA_MFP4	PA.4 Pin Function Selection The pin function depends on GPA_MFP4 and EBI_HB_EN[1] (ALT_MFP[17]) and EBI_EN (ALT_MFP[11]).			
		EBI_HB_EN[1]	EBI_EN	GPA_MFP[4]	PA.4 function
		0	0	0	GPIO
		0	0	1	ADC4 (ADC)
		1	1	1	AD9 (EBI AD bus bit 9)
[3]	GPA_MFP3	PA.3 Pin Function Selection The pin function depends on GPA_MFP3 and EBI_HB_EN[2] (ALT_MFP[18]) and EBI_EN (ALT_MFP[11]).			
		EBI_HB_EN[2]	EBI_EN	GPA_MFP[3]	PA.3 function
		0	0	0	GPIO
		0	0	1	ADC3 (ADC)
		1	1	1	AD10 (EBI AD bus bit 10)
[2]	GPA_MFP2	PA.2 Pin Function Selection The pin function depends on GPA_MFP2 and EBI_HB_EN[3] (ALT_MFP[19]) and EBI_EN (ALT_MFP[11]).			
		EBI_HB_EN[3]	EBI_EN	GPA_MFP[2]	PA.2 function
		0	0	0	GPIO
		0	0	1	ADC2 (ADC)
		1	1	1	AD11 (EBI AD bus bit 11)
[1]	GPA_MFP1	PA.1 Pin Function Selection The pin function depends on GPA_MFP1 and EBI_HB_EN[4] (ALT_MFP[20]) and EBI_EN (ALT_MFP[11]).			
		EBI_HB_EN[4]	EBI_EN	GPA_MFP[1]	PA.1 function
		0	0	0	GPIO
		0	0	1	ADC1 (ADC)
		1	1	1	AD12 (EBI AD bus bit 12)



[0]	GPA_MFP0	PA.0 Pin Function Selection 1 = The ADC0 (Analog-to-Digital converter channel 0) function is selected to the pin PA.0 0 = The GPIOA[0] is selected to the pin PA.0
-----	-----------------	---



Multiple Function Pin GPIOB Control Register (GPB_MFP)

Register	Offset	R/W	Description	Reset Value
GPB_MFP	GCR_BA+0x34	R/W	GPIOB Multiple Function and Input Type Control Register	0x0000_0000

31	30	29	28	27	26	25	24
GPB_TYPE[15:8]							
23	22	21	20	19	18	17	16
GPB_TYPE[7:0]							
15	14	13	12	11	10	9	8
GPB_MFP[15:8]							
7	6	5	4	3	2	1	0
GPB_MFP[7:0]							

Bits	Description													
[31:16]	GPB_TYPE_n	1 = GPIOB[15:0] I/O input Schmitt Trigger function Enabled. 0 = GPIOB[15:0] I/O input Schmitt Trigger function Disabled.												
[15]	GPB_MFP15	<p>PB.15 Pin Function Selection The pin function depends on GPB_MFP15 and PB15_T0EX (ALT_MFP[24])</p> <table border="1" style="width: 100%; text-align: center;"> <thead> <tr> <th>PB15_T0EX</th> <th>GPB_MFP[15]</th> <th>PB.15 Function</th> </tr> </thead> <tbody> <tr> <td>0</td> <td>0</td> <td>GPIO</td> </tr> <tr> <td>0</td> <td>1</td> <td>/INT1</td> </tr> <tr> <td>1</td> <td>1</td> <td>T0EX (TMR0)</td> </tr> </tbody> </table>	PB15_T0EX	GPB_MFP[15]	PB.15 Function	0	0	GPIO	0	1	/INT1	1	1	T0EX (TMR0)
PB15_T0EX	GPB_MFP[15]	PB.15 Function												
0	0	GPIO												
0	1	/INT1												
1	1	T0EX (TMR0)												
[14]	GPB_MFP14	<p>PB.14 Pin Function Selection The pin function depends on GPB_MFP14 and PB14_S31 (ALT_MFP[3])</p> <table border="1" style="width: 100%; text-align: center;"> <thead> <tr> <th>PB14_S31</th> <th>GPB_MFP[14]</th> <th>PB.14 Function</th> </tr> </thead> <tbody> <tr> <td>0</td> <td>0</td> <td>GPIO</td> </tr> <tr> <td>0</td> <td>1</td> <td>/INT0</td> </tr> <tr> <td>1</td> <td>1</td> <td>SPISS31 (SPI3)</td> </tr> </tbody> </table>	PB14_S31	GPB_MFP[14]	PB.14 Function	0	0	GPIO	0	1	/INT0	1	1	SPISS31 (SPI3)
PB14_S31	GPB_MFP[14]	PB.14 Function												
0	0	GPIO												
0	1	/INT0												
1	1	SPISS31 (SPI3)												
[13]	GPB_MFP13	<p>PB.13 Pin Function Selection The pin function depends on GPB_MFP13 and EBI_EN (ALT_MFP[11]).</p> <table border="1" style="width: 100%; text-align: center;"> <thead> <tr> <th>EBI_EN</th> <th>GPB_MFP[13]</th> <th>PB.13 Function</th> </tr> </thead> <tbody> <tr> <td>0</td> <td>0</td> <td>GPIO</td> </tr> <tr> <td>0</td> <td>1</td> <td>CPO1 (CMP)</td> </tr> <tr> <td>1</td> <td>1</td> <td>AD1 (EBI AD bus bit 1)</td> </tr> </tbody> </table>	EBI_EN	GPB_MFP[13]	PB.13 Function	0	0	GPIO	0	1	CPO1 (CMP)	1	1	AD1 (EBI AD bus bit 1)
EBI_EN	GPB_MFP[13]	PB.13 Function												
0	0	GPIO												
0	1	CPO1 (CMP)												
1	1	AD1 (EBI AD bus bit 1)												
[12]	GPB_MFP12	PB.12 Pin Function Selection												



		<p>The pin function depends on GPB_MFP12 and PB12_CLKO (ALT_MFP[10]) and EBI_EN (ALT_MFP[11]).</p> <table border="1"> <thead> <tr> <th>EBI_EN</th> <th>PB12_CLKO</th> <th>GPB_MFP[12]</th> <th>PB.12 Function</th> </tr> </thead> <tbody> <tr> <td>0</td> <td>0</td> <td>0</td> <td>GPIO</td> </tr> <tr> <td>0</td> <td>0</td> <td>1</td> <td>CPO0 (CMP)</td> </tr> <tr> <td>0</td> <td>1</td> <td>1</td> <td>CLKO (Clock Driver output)</td> </tr> <tr> <td>1</td> <td>0</td> <td>1</td> <td>AD0 (EBI AD bus bit 0)</td> </tr> </tbody> </table>	EBI_EN	PB12_CLKO	GPB_MFP[12]	PB.12 Function	0	0	0	GPIO	0	0	1	CPO0 (CMP)	0	1	1	CLKO (Clock Driver output)	1	0	1	AD0 (EBI AD bus bit 0)
EBI_EN	PB12_CLKO	GPB_MFP[12]	PB.12 Function																			
0	0	0	GPIO																			
0	0	1	CPO0 (CMP)																			
0	1	1	CLKO (Clock Driver output)																			
1	0	1	AD0 (EBI AD bus bit 0)																			
[11]	GPB_MFP11	<p>PB.11 Pin Function Selection The pin function depends on GPB_MFP11 and PB11_PWM4 (ALT_MFP[4]).</p> <table border="1"> <thead> <tr> <th>PB11_PWM4</th> <th>GPB_MFP[11]</th> <th>PB.11 Function</th> </tr> </thead> <tbody> <tr> <td>0</td> <td>0</td> <td>GPIO</td> </tr> <tr> <td>0</td> <td>1</td> <td>TM3</td> </tr> <tr> <td>1</td> <td>1</td> <td>PWM4 (PWM)</td> </tr> </tbody> </table>	PB11_PWM4	GPB_MFP[11]	PB.11 Function	0	0	GPIO	0	1	TM3	1	1	PWM4 (PWM)								
PB11_PWM4	GPB_MFP[11]	PB.11 Function																				
0	0	GPIO																				
0	1	TM3																				
1	1	PWM4 (PWM)																				
[10]	GPB_MFP10	<p>PB.10 Pin Function Selection The pin function depends on GPB_MFP10 and PB10_S01 (ALT_MFP[0]).</p> <table border="1"> <thead> <tr> <th>PB10_S01</th> <th>GPB_MFP[10]</th> <th>PB.10 Function</th> </tr> </thead> <tbody> <tr> <td>0</td> <td>0</td> <td>GPIO</td> </tr> <tr> <td>0</td> <td>1</td> <td>TM2</td> </tr> <tr> <td>1</td> <td>1</td> <td>SPISS01 (SPI0)</td> </tr> </tbody> </table>	PB10_S01	GPB_MFP[10]	PB.10 Function	0	0	GPIO	0	1	TM2	1	1	SPISS01 (SPI0)								
PB10_S01	GPB_MFP[10]	PB.10 Function																				
0	0	GPIO																				
0	1	TM2																				
1	1	SPISS01 (SPI0)																				
[9]	GPB_MFP9	<p>PB.9 Pin Function Selection The pin function depends on GPB_MFP9 and PB9_S11 (ALT_MFP[1]).</p> <table border="1"> <thead> <tr> <th>PB9_S11</th> <th>GPB_MFP[9]</th> <th>PB.9 Function</th> </tr> </thead> <tbody> <tr> <td>0</td> <td>0</td> <td>GPIO</td> </tr> <tr> <td>0</td> <td>1</td> <td>TM1</td> </tr> <tr> <td>1</td> <td>1</td> <td>SPISS11 (SPI1)</td> </tr> </tbody> </table>	PB9_S11	GPB_MFP[9]	PB.9 Function	0	0	GPIO	0	1	TM1	1	1	SPISS11 (SPI1)								
PB9_S11	GPB_MFP[9]	PB.9 Function																				
0	0	GPIO																				
0	1	TM1																				
1	1	SPISS11 (SPI1)																				
[8]	GPB_MFP8	<p>PB.8 Pin Function Selection 1 = The TM0 (Timer/Counter external trigger clock input) function is selected to the pin PB.8 0 = The GPIOB[8] is selected to the pin PB.8</p>																				
[7]	GPB_MFP7	<p>PB.7 Pin Function Selection The pin function depends on GPB_MFP7 and EBI_EN (ALT_MFP[11]).</p> <table border="1"> <thead> <tr> <th>EBI_EN</th> <th>GPB_MFP[7]</th> <th>PB.7 Function</th> </tr> </thead> <tbody> <tr> <td>0</td> <td>0</td> <td>GPIO</td> </tr> <tr> <td>0</td> <td>1</td> <td>CTS1 (UART1)</td> </tr> <tr> <td>1</td> <td>1</td> <td>nCS (EBI)</td> </tr> </tbody> </table>	EBI_EN	GPB_MFP[7]	PB.7 Function	0	0	GPIO	0	1	CTS1 (UART1)	1	1	nCS (EBI)								
EBI_EN	GPB_MFP[7]	PB.7 Function																				
0	0	GPIO																				
0	1	CTS1 (UART1)																				
1	1	nCS (EBI)																				
[6]	GPB_MFP6	<p>PB.6 Pin Function Selection The pin function depends on GPB_MFP6 and EBI_EN (ALT_MFP[11]).</p>																				



		EBI_EN	GPB_MFP[6]	PB.6 Function		
		0	0	GPIO		
		0	1	RTS1 (UART1)		
		1	1	ALE (EBI)		
[5]	GPB_MFP5	PB.5 Pin Function Selection 1 = The UART1 TXD function is selected to the pin PB.5 0 = The GPIOB[5] is selected to the pin PB.5				
[4]	GPB_MFP4	PB.4 Pin Function Selection 1 = The UART1 RXD function is selected to the pin PB.4 0 = The GPIOB[4] is selected to the pin PB.4				
[3]	GPB_MFP3	PB.3 Pin Function Selection The pin function depends on GPB_MFP3 and EBI_nWRH_EN (ALT_MFP[14]) and EBI_EN (ALT_MFP[11]) and PB3_T3EX (ALT_MFP[27]).				
		EBI_nWRH_EN	EBI_EN	GPB_MFP[3]	PB3_T3EX	PB.3 Function
		0	0	0	0	GPIO
		0	0	1	0	CTS0 (UART0)
		1	1	1	0	nWRH (EBI write high byte enable)
0	0	1	1	T3EX (TMR3)		
[2]	GPB_MFP2	PB.2 Pin Function Selection The pin function depends on GPB_MFP2 and EBI_nWRL_EN (ALT_MFP[13]) and EBI_EN (ALT_MFP[11]) and PB2_T2EX (ALT_MFP[26]).				
		EBI_nWRL_EN	EBI_EN	GPB_MFP[2]	PB2_T2EX	PB.2 Function
		0	0	0	0	GPIO
		0	0	1	0	RTS0 (UART0)
		1	1	1	0	nWRL (EBI write low byte enable)
0	0	1	1	T2EX (TMR2)		
[1]	GPB_MFP1	PB.1 Pin Function Selection 1 = The UART0 TXD function is selected to the pin PB.1 0 = The GPIOB[1] is selected to the pin PB.1				
[0]	GPB_MFP0	PB.0 Pin Function Selection 1 = The UART0 RXD function is selected to the pin PB.0 0 = The GPIOB[0] is selected to the pin PB.0				



Multiple Function Pin GPIOC Control Register (GPC_MFP)

Register	Offset	R/W	Description	Reset Value
GPC_MFP	GCR_BA+0x38	R/W	GPIOC Multiple Function and Input Type Control Register	0x0000_0000

31	30	29	28	27	26	25	24
GPC_TYPE[15:8]							
23	22	21	20	19	18	17	16
GPC_TYPE[7:0]							
15	14	13	12	11	10	9	8
GPC_MFP[15:8]							
7	6	5	4	3	2	1	0
GPC_MFP[7:0]							

Bits	Description			
[31:16]	GPC_TYPEn	1 = GPIOC[15:0] I/O input Schmitt Trigger function Enabled. 0 = GPIOC[15:0] I/O input Schmitt Trigger function Disabled.		
[15]	GPC_MFP15	PC.15 Pin Function Selection The pin function depends on GPC_MFP15 and EBI_EN (ALT_MFP[11]).		
		EBI_EN	GPC_MFP[15]	PC.15 Function
		0	0	GPIO
		0	1	CPN1 (CMP)
1	1	AD3 (EBI AD bus bit 3)		
[14]	GPC_MFP14	PC.14 Pin Function Selection The pin function depends on GPC_MFP14 and EBI_EN (ALT_MFP[11]).		
		EBI_EN	GPC_MFP[14]	PC.14 Function
		0	0	GPIO
		0	1	CPP1 (CMP)
1	1	AD2 (EBI AD bus bit 2)		
[13]	GPC_MFP13	PC.13 Pin Function Selection 1 = The SPI1 MOSI1 (master output, slave input pin-1) function is selected to the pin PC.13 0 = The GPIOC[13] is selected to the pin PC.13		
[12]	GPC_MFP12	PC.12 Pin Function Selection 1 = The SPI1 MISO1 (master input, slave output pin-1) function is selected to the pin PC.12 0 = The GPIOC[12] is selected to the pin PC.12		



[11]	GPC_MFP11	<p>PC.11 Pin Function Selection</p> <p>1 = The SPI1 MOSI0 (master output, slave input pin-0) function is selected to the pin PC.11</p> <p>0 = The GPIOC[11] is selected to the pin PC.11</p>																
[10]	GPC_MFP10	<p>PC.10 Pin Function Selection</p> <p>1 = The SPI1 MISO0 (master input, slave output pin-0) function is selected to the pin PC.10</p> <p>0 = The GPIOC[10] is selected to the pin PC.10</p>																
[9]	GPC_MFP9	<p>PC.9 Pin Function Selection</p> <p>1 = The SPI1 SPICLK function is selected to the pin PC.9</p> <p>0 = The GPIOC[9] is selected to the pin PC.9</p>																
[8]	GPC_MFP8	<p>PC.8 Pin Function Selection</p> <p>The pin function depends on GPC_MFP8 and EBI_MCLK_EN (ALT_MFP[12]) and EBI_EN (ALT_MFP[11]).</p> <table border="1" style="width: 100%; border-collapse: collapse;"> <thead> <tr> <th style="width: 15%;">EBI_MCLK_EN</th> <th style="width: 15%;">EBI_EN</th> <th style="width: 15%;">GPC_MFP[8]</th> <th style="width: 55%;">PC.8 Function</th> </tr> </thead> <tbody> <tr> <td style="text-align: center;">0</td> <td style="text-align: center;">0</td> <td style="text-align: center;">0</td> <td>GPIO</td> </tr> <tr> <td style="text-align: center;">0</td> <td style="text-align: center;">0</td> <td style="text-align: center;">1</td> <td>SPISS10 (SPI1)</td> </tr> <tr> <td style="text-align: center;">1</td> <td style="text-align: center;">1</td> <td style="text-align: center;">1</td> <td>MCLK (EBI Clock output)</td> </tr> </tbody> </table>	EBI_MCLK_EN	EBI_EN	GPC_MFP[8]	PC.8 Function	0	0	0	GPIO	0	0	1	SPISS10 (SPI1)	1	1	1	MCLK (EBI Clock output)
EBI_MCLK_EN	EBI_EN	GPC_MFP[8]	PC.8 Function															
0	0	0	GPIO															
0	0	1	SPISS10 (SPI1)															
1	1	1	MCLK (EBI Clock output)															
[7]	GPC_MFP7	<p>PC.7 Pin Function Selection</p> <p>The pin function depends on GPC_MFP7 and EBI_EN (ALT_MFP[11]).</p> <table border="1" style="width: 100%; border-collapse: collapse;"> <thead> <tr> <th style="width: 15%;">EBI_EN</th> <th style="width: 15%;">GPC_MFP[7]</th> <th style="width: 70%;">PC.7 Function</th> </tr> </thead> <tbody> <tr> <td style="text-align: center;">0</td> <td style="text-align: center;">0</td> <td>GPIO</td> </tr> <tr> <td style="text-align: center;">0</td> <td style="text-align: center;">1</td> <td>CPN0 (CMP)</td> </tr> <tr> <td style="text-align: center;">1</td> <td style="text-align: center;">1</td> <td>AD5 (EBI AD bus bit 5)</td> </tr> </tbody> </table>	EBI_EN	GPC_MFP[7]	PC.7 Function	0	0	GPIO	0	1	CPN0 (CMP)	1	1	AD5 (EBI AD bus bit 5)				
EBI_EN	GPC_MFP[7]	PC.7 Function																
0	0	GPIO																
0	1	CPN0 (CMP)																
1	1	AD5 (EBI AD bus bit 5)																
[6]	GPC_MFP6	<p>PC.6 Pin Function Selection</p> <p>The pin function depends on GPC_MFP6 and EBI_EN (ALT_MFP[11]).</p> <table border="1" style="width: 100%; border-collapse: collapse;"> <thead> <tr> <th style="width: 15%;">EBI_EN</th> <th style="width: 15%;">GPC_MFP[6]</th> <th style="width: 70%;">PC.6 Function</th> </tr> </thead> <tbody> <tr> <td style="text-align: center;">0</td> <td style="text-align: center;">0</td> <td>GPIO</td> </tr> <tr> <td style="text-align: center;">0</td> <td style="text-align: center;">1</td> <td>CPP0 (CMP)</td> </tr> <tr> <td style="text-align: center;">1</td> <td style="text-align: center;">1</td> <td>AD4 (EBI AD bus bit 4)</td> </tr> </tbody> </table>	EBI_EN	GPC_MFP[6]	PC.6 Function	0	0	GPIO	0	1	CPP0 (CMP)	1	1	AD4 (EBI AD bus bit 4)				
EBI_EN	GPC_MFP[6]	PC.6 Function																
0	0	GPIO																
0	1	CPP0 (CMP)																
1	1	AD4 (EBI AD bus bit 4)																
[5]	GPC_MFP5	<p>PC.5 Pin Function Selection</p> <p>1 = The SPI0 MOSI1 (master output, slave input pin-1) function is selected to the pin PC.5</p> <p>0 = The GPIOC[5] is selected to the pin PC.5</p>																
[4]	GPC_MFP4	<p>PC.4 Pin Function Selection</p> <p>1 = The SPI0 MISO1 (master input, slave output pin-1) function is selected to the pin PC.4</p> <p>0 = The GPIOC[4] is selected to the pin PC.4</p>																
[3]	GPC_MFP3	<p>PC.3 Pin Function Selection</p> <p>Bits PC3_I2SDO (ALT_MFP[8]) and GPC_MFP[3] determine the PC.3 function.</p>																



		PC3_I2SDO	GPC_MFP[3]	PC.3 Function
		0	0	GPIO
		0	1	MOSI00 (SPI0)
		1	1	I2SDO (I ² S)
[2]	GPC_MFP2	PC.2 Pin Function Selection Bits PC2_I2SDI (ALT_MFP[7]) and GPC_MFP[2] determine the PC.2 function.		
		PC2_I2SDI	GPC_MFP[2]	PC.2 Function
		0	0	GPIO
		0	1	MISO00 (SPI0)
		1	1	I2SDI (I ² S)
[1]	GPC_MFP1	PC.1 Pin Function Selection Bits PC1_I2SBCLK (ALT_MFP[6]) and GPC_MFP[1] determine the PC.1 function.		
		PC1_I2SBCLK	GPC_MFP[1]	PC.1 Function
		0	0	GPIO
		0	1	SPICLK0 (SPI0)
		1	1	I2SBCLK (I ² S)
[0]	GPC_MFP0	PC.0 Pin Function Selection Bits PC0_I2SLRCLK (ALT_MFP[5]) and GPC_MFP[0] determine the PC.0 function.		
		PC0_I2SLRCLK	GPC_MFP[0]	PC.0 Function
		0	0	GPIO
		0	1	SPISS00 (SPI0)
		1	1	I2SLRCLK (I ² S)



Multiple Function Pin GPIOD Control Register (GPD_MFP)

Register	Offset	R/W	Description	Reset Value
GPD_MFP	GCR_BA+0x3C	R/W	GPIOD Multiple Function and Input Type Control Register	0x0000_0000

31	30	29	28	27	26	25	24
GPD_TYPE[15:8]							
23	22	21	20	19	18	17	16
GPD_TYPE[7:0]							
15	14	13	12	11	10	9	8
GPD_MFP[15:8]							
7	6	5	4	3	2	1	0
GPD_MFP[7:0]							

Bits	Description	
[31:16]	GPD_TYPEn	1 = GPIOD[15:0] I/O input Schmitt Trigger function Enabled. 0 = GPIOD[15:0] I/O input Schmitt Trigger function Disabled.
[15]	GPD_MFP15	PD.15 Pin Function Selection 1 = The UART2 TXD function is selected to the pin PD.15 0 = The GPIOD[15] selected to the pin PD.15
[14]	GPD_MFP14	PD.14 Pin Function Selection 1 = The UART2 RXD function is selected to the pin PD.14 0 = The GPIOD[14] selected to the pin PD.14
[13]	GPD_MFP13	PD.13 Pin Function Selection 1 = The SPI3 MOSI1 (master output, slave input pin-1) function is selected to the pin PD.13 0 = The GPIOD[13] is selected to the pin PD.13
[12]	GPD_MFP12	PD.12 Pin Function Selection 1 = The SPI3 MISO1 (master input, slave output pin-1) function is selected to the pin PD.12 0 = The GPIOD[12] is selected to the pin PD.12
[11]	GPD_MFP11	PD.11 Pin Function Selection 1 = The SPI3 MOSI0 (master output, slave input pin-0) function is selected to the pin PD.11 0 = The GPIOD[11] is selected to the pin PD.11
[10]	GPD_MFP10	PD.10 Pin Function Selection 1 = The SPI3 MISO0 (master input, slave output pin-0) function is selected to the pin PD.10 0 = The GPIOD[10] is selected to the pin PD.10



[9]	GPD_MFP9	PD.9 Pin Function Selection 1 = The SPI3 SPICLK function is selected to the pin PD.9 0 = The GPIOD[9] is selected to the pin PD.9
[8]	GPD_MFP8	PD.8 Pin Function Selection 1 = The SPI3 SS30 function is selected to the pin PD8 0 = The GPIOD[8] is selected to the pin PD8
[7]	GPD_MFP7	PD.7 Pin Function Selection 1 = The CAN0 TX function is selected to the pin PD.7 0 = The GPIOD[7] is selected to the pin PD.7
[6]	GPD_MFP6	PD.6 Pin Function Selection 1 = The CAN0 RX function is selected to the pin PD.6 0 = The GPIOD[6] is selected to the pin PD.6
[5]	GPD_MFP5	PD.5 Pin Function Selection 1 = The SPI2 MOSI1 (master output, slave input pin-1) function is selected to the pin PD.5 0 = The GPIOD[5] is selected to the pin PD.5
[4]	GPD_MFP4	PD.4 Pin Function Selection 1 = The SPI2 MISO1 (master input, slave output pin-1) function is selected to the pin PD.4 0 = The GPIOD[4] is selected to the pin PD.4
[3]	GPD_MFP3	PD.3 Pin Function Selection 1 = The SPI2 MOSI0 (master output, slave input pin-0) function is selected to the pin PD.3 0 = The GPIOD[3] is selected to the pin PD.3
[2]	GPD_MFP2	PD.2 Pin Function Selection 1 = The SPI2 MISO0 (master input, slave output pin-0) function is selected to the pin PD.2 0 = The GPIOD[2] is selected to the pin PD.2
[1]	GPD_MFP1	PD.1 Pin Function Selection 1 = The SPI2 SPICLK function is selected to the pin PD.1 0 = The GPIOD[1] is selected to the pin PD.1
[0]	GPD_MFP0	PD.0 Pin Function Selection 1 = The SPI2 SS20 function is selected to the pin PD.0 0 = The GPIOD[0] is selected to the pin PD.0



Multiple Function Pin GPIOE Control Register (GPE_MFP)

Register	Offset	R/W	Description	Reset Value
GPE_MFP	GCR_BA+0x40	R/W	GPIOE Multiple Function and Input Type Control Register	0x0000_0000

31	30	29	28	27	26	25	24
GPE_TYPE[15:8]							
23	22	21	20	19	18	17	16
GPE_TYPE[7:0]							
15	14	13	12	11	10	9	8
Reserved							
7	6	5	4	3	2	1	0
Reserved		GPE_MFP5	Reserved			GPE_MFP1	GPE_MFP0

Bits	Description													
[31:16]	GPE_TYPEn	1 = GPIOE[15:0] I/O input Schmitt Trigger function Enabled. 0 = GPIOE[15:0] I/O input Schmitt Trigger function Disabled.												
[15:6]	Reserved	Reserved												
[5]	GPE_MFP5	PE.5 Pin Function Selection The pin function depends on GPE_MFP5 and PE5_T1EX (ALT_MFP[25])												
		<table border="1" style="width: 100%; border-collapse: collapse;"> <thead> <tr> <th style="width: 20%;">PE5_T1EX</th> <th style="width: 20%;">GPE_MFP[5]</th> <th style="width: 60%;">PE.5 Function</th> </tr> </thead> <tbody> <tr> <td style="text-align: center;">0</td> <td style="text-align: center;">0</td> <td>GPIO</td> </tr> <tr> <td style="text-align: center;">0</td> <td style="text-align: center;">1</td> <td>PWM5 (PWM)</td> </tr> <tr> <td style="text-align: center;">1</td> <td style="text-align: center;">1</td> <td>T1EX (TMR1)</td> </tr> </tbody> </table>	PE5_T1EX	GPE_MFP[5]	PE.5 Function	0	0	GPIO	0	1	PWM5 (PWM)	1	1	T1EX (TMR1)
		PE5_T1EX	GPE_MFP[5]	PE.5 Function										
		0	0	GPIO										
0	1	PWM5 (PWM)												
1	1	T1EX (TMR1)												
Reserved														
[4:2]	Reserved	Reserved												
[1]	GPE_MFP1	PE.1 Pin Function Selection 1 = The PWM7 function is selected to the pin PE.1 0 = The GPIOE[1] is selected to the pin PE.1												
[0]	GPE_MFP0	PE.0 Pin Function Selection 1 = The PWM6 function is selected to the pin PE.0 0 = The GPIOE[0] is selected to the pin PE.0												



Alternative Multiple Function Pin Control Register (ALT_MFP)

Register	Offset	R/W	Description	Reset Value
ALT_MFP	GCR_BA+0x50	R/W	Alternative Multiple Function Pin Control Register	0x0000_0000

31	30	29	28	27	26	25	24
Reserved				PB3_T3EX	PB2_T2EX	PE5_T1EX	PB15_T0EX
23	22	21	20	19	18	17	16
EBI_HB_EN							
15	14	13	12	11	10	9	8
Reserved	EBI_nWRH_EN	EBI_nWRL_EN	EBI_MCLK_EN	EBI_EN	PB12_CLKO	PA15_I2SMCLK	PC3_I2SDO
7	6	5	4	3	2	1	0
PC2_I2SDI	PC1_I2SBCLK	PC0_I2SLRLK	PB11_PWM4	PB14_S31	PA7_S21	PB9_S11	PB10_S01

Bits	Description	Description																									
[31:24]	Reserved	Reserved																									
[27]	PB3_T3EX	Bits GPB_MFP3 and EBI_nWRH_EN (ALT_MFP[14]) and EBI_EN (ALT_MFP[11]) and PB3_T3EX (ALT_MFP[27]) determine the PB.3 function.																									
		<table border="1" style="width: 100%; text-align: center;"> <thead> <tr> <th>EBI_nWRH_EN</th> <th>EBI_EN</th> <th>GPB_MFP[3]</th> <th>PB3_T3EX</th> <th>PB.3 Function</th> </tr> </thead> <tbody> <tr> <td>0</td> <td>0</td> <td>0</td> <td>0</td> <td>GPIO</td> </tr> <tr> <td>0</td> <td>0</td> <td>1</td> <td>1</td> <td>CTS0 (UART0)</td> </tr> <tr> <td>1</td> <td>1</td> <td>1</td> <td>1</td> <td>nWRH (EBI write high byte enable)</td> </tr> <tr> <td>0</td> <td>0</td> <td>1</td> <td>1</td> <td>T3EX (TMR3)</td> </tr> </tbody> </table>	EBI_nWRH_EN	EBI_EN	GPB_MFP[3]	PB3_T3EX	PB.3 Function	0	0	0	0	GPIO	0	0	1	1	CTS0 (UART0)	1	1	1	1	nWRH (EBI write high byte enable)	0	0	1	1	T3EX (TMR3)
		EBI_nWRH_EN	EBI_EN	GPB_MFP[3]	PB3_T3EX	PB.3 Function																					
		0	0	0	0	GPIO																					
		0	0	1	1	CTS0 (UART0)																					
1	1	1	1	nWRH (EBI write high byte enable)																							
0	0	1	1	T3EX (TMR3)																							
[26]	PB2_T2EX	Bits GPB_MFP2 and EBI_nWRL_EN (ALT_MFP[13]) and EBI_EN (ALT_MFP[11]) and PB2_T2EX (ALT_MFP[26]) determine the PB.2 function.																									
		<table border="1" style="width: 100%; text-align: center;"> <thead> <tr> <th>EBI_nWRL_EN</th> <th>EBI_EN</th> <th>GPB_MFP[2]</th> <th>PB2_T2EX</th> <th>PB.2 Function</th> </tr> </thead> <tbody> <tr> <td>0</td> <td>0</td> <td>0</td> <td>0</td> <td>GPIO</td> </tr> <tr> <td>0</td> <td>0</td> <td>1</td> <td>0</td> <td>RTS0 (UART0)</td> </tr> <tr> <td>1</td> <td>1</td> <td>1</td> <td>0</td> <td>nWRL (EBI write low byte enable)</td> </tr> <tr> <td>0</td> <td>0</td> <td>1</td> <td>1</td> <td>T2EX (TMR2)</td> </tr> </tbody> </table>	EBI_nWRL_EN	EBI_EN	GPB_MFP[2]	PB2_T2EX	PB.2 Function	0	0	0	0	GPIO	0	0	1	0	RTS0 (UART0)	1	1	1	0	nWRL (EBI write low byte enable)	0	0	1	1	T2EX (TMR2)
		EBI_nWRL_EN	EBI_EN	GPB_MFP[2]	PB2_T2EX	PB.2 Function																					
		0	0	0	0	GPIO																					
		0	0	1	0	RTS0 (UART0)																					
1	1	1	0	nWRL (EBI write low byte enable)																							
0	0	1	1	T2EX (TMR2)																							
[25]	PE5_T1EX	Bits GPE_MFP5 and PE5_T1EX (ALT_MFP[25]) determine the PE.5 function.																									
		<table border="1" style="width: 100%; text-align: center;"> <thead> <tr> <th>PE5_T1EX</th> <th>GPE_MFP[5]</th> <th>PE.5 Function</th> </tr> </thead> <tbody> <tr> <td>0</td> <td>0</td> <td>GPIO</td> </tr> </tbody> </table>	PE5_T1EX	GPE_MFP[5]	PE.5 Function	0	0	GPIO																			
		PE5_T1EX	GPE_MFP[5]	PE.5 Function																							
0	0	GPIO																									



		0	1	PWM5 (PWM)	
		1	1	T1EX (TMR1)	
[24]	PB15_T0EX	Bits GPB_MFP15 and PB15_T0EX (ALT_MFP[24]) determine the PB.15 function.			
		PB15_T0EX	GPB_MFP[15]	PB.15 Function	
		0	0	GPIO	
		0	1	/INT1	
		1	1	T0EX (TMR0)	
[23]	EBI_HB_EN[7]	EBI_HB_EN is use to switch GPIO function to EBI address/data bus high byte (AD[15:8]), EBI_HB_EN, EBI_EN and corresponding GPx_MFP[y] determine the Px.y function. Bits EBI_HB_EN[7], EBI_EN and GPA_MFP[14] determine the PA.14 function.			
		EBI_HB_EN[7]	EBI_EN	GPA_MFP[14]	PA.14 Function
		0	0	0	GPIO
		0	0	1	PWM2 (PWM)
		1	1	1	AD15 (EBI AD bus bit 15)
[22]	EBI_HB_EN[6]	Bits EBI_HB_EN[6], EBI_EN and GPA_MFP[13] determine the PA.13 function.			
		EBI_HB_EN[6]	EBI_EN	GPA_MFP[13]	PA.13 Function
		0	0	0	GPIO
		0	0	1	PWM1 (PWM)
		1	1	1	AD14 (EBI AD bus bit 14)
[21]	EBI_HB_EN[5]	Bits EBI_HB_EN[5], EBI_EN and GPA_MFP[12] determine the PA.12 function.			
		EBI_HB_EN[5]	EBI_EN	GPA_MFP[12]	PA.12 Function
		0	0	0	GPIO
		0	0	1	PWM0 (PWM)
		1	1	1	AD13 (EBI AD bus bit 13)
[20]	EBI_HB_EN[4]	Bits EBI_HB_EN[4], EBI_EN and GPA_MFP[1] determine the PA.1 function.			
		EBI_HB_EN[4]	EBI_EN	GPA_MFP[1]	PA.1 Function
		0	0	0	GPIO
		0	0	1	ADC1 (ADC)
		1	1	1	AD12 (EBI AD bus bit 12)
[19]	EBI_HB_EN[3]	Bits EBI_HB_EN[3], EBI_EN and GPA_MFP[2] determine the PA.2 function.			
		EBI_HB_EN[3]	EBI_EN	GPA_MFP[2]	PA.2 Function
		0	0	0	GPIO
		0	0	1	ADC2 (ADC)
		1	1	1	AD11 (EBI AD bus bit 11)
[18]	EBI_HB_EN[2]	Bits EBI_HB_EN[2], EBI_EN and GPA_MFP[3] determine the PA.3 function.			



		EBI_HB_EN[2]	EBI_EN	GPA_MFP[3]	PA.3 Function
		0	0	0	GPIO
		0	0	1	ADC3 (ADC)
		1	1	1	AD10 (EBI AD bus bit 10)
[17]	EBI_HB_EN[1]	Bits EBI_HB_EN[1], EBI_EN and GPA_MFP[4] determine the PA.4 function.			
		EBI_HB_EN[1]	EBI_EN	GPA_MFP[4]	PA.4 Function
		0	0	0	GPIO
		0	0	1	ADC4 (ADC)
		1	1	1	AD9 (EBI AD bus bit 9)
[16]	EBI_HB_EN[0]	Bits EBI_HB_EN[0], EBI_EN and GPA_MFP[5] determine the PA.5 function.			
		EBI_HB_EN[0]	EBI_EN	GPA_MFP[5]	PA.5 Function
		0	0	0	GPIO
		0	0	1	ADC5 (ADC)
		1	1	1	AD8 (EBI AD bus bit 8)
[15]	Reserved	Reserved			
[14]	EBI_nWRH_EN	Bits EBI_nWRH_EN, EBI_EN and GPB_MFP[3] determine the PB.3 function.			
		EBI_nWRH_EN	EBI_EN	GPB_MFP[3]	PB.3 Function
		0	0	0	GPIO
		0	0	1	CTS0 (UART0)
		1	1	1	nWRH (EBI write high byte enable)
[13]	EBI_nWRL_EN	Bits EBI_nWRL_EN, EBI_EN and GPB_MFP[2] determine the PB.2 function.			
		EBI_nWRL_EN	EBI_EN	GPB_MFP[2]	PB.2 Function
		0	0	0	GPIO
		0	0	1	RTS0 (UART0)
		1	1	1	nWRL (EBI write low byte enable)
[12]	EBI_MCLK_EN	Bits EBI_MCLK_EN, EBI_EN and GPC_MFP[8] determine the PC.8 function.			
		EBI_MCLK_EN	EBI_EN	GPC_MFP[8]	PC.8 Function
		0	0	0	GPIO
		0	0	1	SPISS10 (SPI1)
		1	1	1	MCLK (EBI Clock output)
[11]	EBI_EN	EBI_EN is use to switch GPIO function to EBI function (AD[15:0], ALE, RE, WE, CS, MCLK), it need additional registers EBI_EN[7:0] and EBI_MCLK_EN for some GPIO to switch to EBI function(AD[15:8], MCLK)			
		EBI_EN	GPA_MFP[6]	PA.6 Function	



0	0	GPIO	
0	1	ADC5 (ADC)	
1	1	AD7 (EBI AD bus bit 7)	
EBI_EN GPA_MFP[7] PA.7 Function			
0	0	GPIO	
0	1	ADC7 (ADC)	
1	1	AD6 (EBI AD bus bit 6)	
EBI_EN GPC_MFP[7] PC.7 Function			
0	0	GPIO	
0	1	CPN0 (CMP)	
1	1	AD5 (EBI AD bus bit 5)	
EBI_EN GPC_MFP[6] PC.6 Function			
0	0	GPIO	
0	1	CPP0 (CMP)	
1	1	AD4 (EBI AD bus bit 4)	
EBI_EN GPC_MFP[15] PC.15 Function			
0	0	GPIO	
0	1	CPN1 (CMP)	
1	1	AD3 (EBI AD bus bit 3)	
EBI_EN GPC_MFP[14] PC.14 Function			
0	0	GPIO	
0	1	CPP1 (CMP)	
1	1	AD2 (EBI AD bus bit 2)	
EBI_EN GPB_MFP[13] PB.13 Function			
0	0	GPIO	
0	1	CPO1 (CMP)	
1	1	AD1 (EBI AD bus bit 1)	
EBI_EN PB12_CLKO GPB_MFP[12] PB.12 Function			



		0	0	0	GPIO
		0	0	1	CPO0 (CMP)
		0	1	1	CLKO (Clock Driver output)
		1	1	1	AD0 (EBI AD bus bit 0)
		EBI_EN	GPA_MFP[11]	PA.11 Function	
		0	0	GPIO	
		0	1	SCL1 (I ² C)	
		1	1	nRD (EBI)	
		EBI_EN	GPA_MFP[10]	PA.10 Function	
		0	0	GPIO	
		0	1	SDA1 (I ² C)	
		1	1	nWR (EBI)	
		EBI_EN	GPB_MFP[6]	PB.6 Function	
		0	0	GPIO	
		0	1	RTS1 (UART1)	
		1	1	ALE (EBI)	
EBI_EN	GPB_MFP[7]	PB.7 Function			
0	0	GPIO			
0	1	CTS1 (UART1)			
1	1	nCS (EBI)			
[10]	PB12_CLKO	Bits PB12_CLKO, GPB_MFP[12] and EBI_EN (ALT_MFP[11]) determine the PB.12 function.			
		EBI_EN	PB12_CLKO	GPB_MFP[12]	PB.12 Function
		0	0	0	GPIO
		0	0	1	CPO0 (CMP)
		0	1	1	CLKO (Clock Driver output)
		1	1	1	AD0 (EBI AD bus bit 0)
[9]	PA15_I2SMCLK	Bits PA15_I2SMCLK and GPA_MFP[15] determine the PA.15 function.			
		PA15_I2SMCLK	GPA_MFP[15]	PA.15 Function	
		0	0	GPIO	
		0	1	PWM3 (PWM)	



		1	1	I2SMCLK (I ² S)	
[8]	PC3_I2SDO	Bits PC3_I2SDO and GPC_MFP[3] determine the PC.3 function.			
		PC3_I2SDO	GPC_MFP[3]	PC.3 Function	
		0	0	GPIO	
		0	1	MOSI00 (SPI0)	
		1	1	I2SDO (I ² S)	
[7]	PC2_I2SDI	Bits PC2_I2SDI and GPC_MFP[2] determine the PC.2 function.			
		PC2_I2SDI	GPC_MFP[2]	PC.2 Function	
		0	0	GPIO	
		0	1	MISO00 (SPI0)	
		1	1	I2SDI (I ² S)	
[6]	PC1_I2SBCLK	Bits PC1_I2SBCLK and GPC_MFP[1] determine the PC.1 function.			
		PC1_I2SBCLK	GPC_MFP[1]	PC.1 Function	
		0	0	GPIO	
		0	1	SPICLK0 (SPI0)	
		1	1	I2SBCLK (I ² S)	
[5]	PC0_I2SLRCLK	Bits PC0_I2SLRCLK and GPC_MFP[0] determine the PC.0 function.			
		PC0_I2SLRCLK	GPC_MFP[0]	PC.0 Function	
		0	0	GPIO	
		0	1	SPISS00 (SPI0)	
		1	1	I2SLRCLK (I ² S)	
[4]	PB11_PWM4	Bits PB11_PWM4 and GPB_MFP[11] determine the PB.11 function.			
		PB11_PWM4	GPB_MFP[11]	PB.11 Function	
		0	0	GPIO	
		0	1	TM3	
		1	1	PWM4 (PWM)	
[3]	PB14_S31	Bits PB14_S31 and GPB_MFP[14] determine the PB.14 function.			
		PB14_S31	GPB_MFP[14]	PB.14 Function	
		0	0	GPIO	
		0	1	/INT0	
		1	1	SPISS31 (SPI3)	
[2]	PA7_S21	Bits PA7_S21, GPA_MFP[7] and EBI_EN (ALT_MFP[11]).determine the PA.7 function.			
		EBI_EN	PA7_S21	GPA_MFP[7]	PA.7 Function
		0	0	0	GPIO



		0	0	1	ADC7 (ADC)
		0	1	1	SPISS21 (SPI2)
		1	0	1	AD6 (EBI AD bus bit 6)
[1]	PB9_S11	Bits PB9_S11 and GPB_MFP[9] determine the PB.9 function.			
		PB9_S11	GPB_MFP[9]	PB.9 Function	
		0	0	GPIO	
		0	1	TM1	
		1	1	SPISS11 (SPI1)	
[0]	PB10_S01	Bits PB10_S01 and GPB_MFP[10] determine the PB.10 function.			
		PB10_S01	GPB_MFP[10]	PB.10 Function	
		0	0	GPIO	
		0	1	TM2	
		1	1	SPISS01 (SPI0)	



Register Write-Protection Control Register (REGWRPROT)

Some of the system control registers need to be protected to avoid inadvertent write and disturb the chip operation. These system control registers are protected after the power on reset till user to disable register protection. For user to program these protected registers, a register protection disable sequence needs to be followed by a special programming. The register protection disable sequence is writing the data “59h”, “16h” “88h” to the register REGWRPROT address at 0x5000_0100 continuously. Any different data value, different sequence or any other write to other address during these three data writing will abort the whole sequence.

After the protection is disabled, user can check the protection disable bit at address 0x5000_0100 bit0, 1 is protection disable, and 0 is protection enable. Then user can update the target protected register value and then write any data to the address “0x5000_0100” to enable register protection.

This register is write for disable/enable register protection and read for the REGPROTDIS status

Register	Offset	R/W	Description	Reset Value
REGWRPROT	GCR_BA+0x100	R/W	Register Write Protect register	0x0000_0000

31	30	29	28	27	26	25	24
Reserved							
23	22	21	20	19	18	17	16
Reserved							
15	14	13	12	11	10	9	8
Reserved							
7	6	5	4	3	2	1	0
REGWRPROT[7:1]							REGWRPROT [0] REGPROTDIS

Bits	Description
[31:16]	Reserved
[7:0]	<p>REGWRPROT</p> <p>Register Write-Protection Code (Write Only)</p> <p>Some registers have write-protection function. Writing these registers have to disable the protected function by writing the sequence value “59h”, “16h”, “88h” to this field. After this sequence is completed, the REGPROTDIS bit will be set to 1 and write-protection registers can be normal write.</p>
[0]	<p>REGPROTDIS</p> <p>Register Write-Protection Disable index (Read only)</p> <p>1 = Write-protection Disabled for writing protected registers</p> <p>0 = Write-protection Enabled for writing protected registers. Any write to the protected register is ignored.</p> <p>The Protected registers are:</p> <p>IPRSTC1: address 0x5000_0008</p> <p>BODCR: address 0x5000_0018</p> <p>PORCR: address 0x5000_0024</p>



		<p>PWRCON: address 0x5000_0200 (bit[6] is not protected for power wake-up interrupt clear)</p> <p>APBCLK bit[0]: address 0x5000_0208 (bit[0] is watchdog clock enable)</p> <p>CLKSELO: address 0x5000_0210 (for HCLK and CPU STCLK clock source select)</p> <p>CLKSEL1 bit[1:0]: address 0x5000_0214 (for watchdog clock source select)</p> <p>NMI_SEL bit[8]: address 0x5000_0380 (for NMI_EN clock source select)</p> <p>ISPCON: address 0x5000_C000 (Flash ISP Control register)</p> <p>ISPTRG: address 0x5000_C010 (ISP Trigger Control register)</p> <p>WTCR: address 0x4000_4000</p> <p>FATCON: address 0x5000_C018</p>
--	--	--



5.2.6 System Timer (SysTick)

The Cortex-M0 includes an integrated system timer, SysTick. SysTick provides a simple, 24-bit clear-on-write, decrementing, wrap-on-zero counter with a flexible control mechanism. The counter can be used as a Real Time Operating System (RTOS) tick timer or as a simple counter.

When system timer is enabled, it will count down from the value in the SysTick Current Value Register (SYST_CVR) to 0, and reload (wrap) to the value in the SysTick Reload Value Register (SYST_RVR) on the next clock cycle, then decrement on subsequent clocks. When the counter transitions to 0, the COUNTFLAG status bit is set. The COUNTFLAG bit clears on reads.

The SYST_CVR value is UNKNOWN on reset. Software should write to the register to clear it to 0 before enabling the feature. This ensures the timer will count from the SYST_RVR value rather than an arbitrary value when it is enabled.

If the SYST_RVR is zero, the timer will be maintained with a current value of zero after it is reloaded with this value. This mechanism can be used to disable the feature independently from the timer enable bit.

For more detailed information, please refer to the “ARM® Cortex™-M0 Technical Reference Manual” and “ARM® v6-M Architecture Reference Manual”.



5.2.6.1 System Timer Control Register Map

R: read only, W: write only, R/W: both read and write

Register	Offset	R/W	Description	Reset Value
SCS Base Address:				
SCS_BA = 0xE000_E000				
SYST_CSR	SCS_BA+0x10	R/W	SysTick Control and Status Register	0x0000_0000
SYST_RVR	SCS_BA+0x14	R/W	SysTick Reload Value Register	0xFFFF_FFFF
SYST_CVR	SCS_BA+0x18	R/W	SysTick Current Value Register	0xFFFF_FFFF



5.2.6.2 System Timer Control Register Description

SysTick Control and Status (SYST_CSR)

Register	Offset	R/W	Description	Reset Value
SYST_CSR	SCS_BA+0x10	R/W	SysTick Control and Status Register	0x0000_0000

31	30	29	28	27	26	25	24
Reserved							
23	22	21	20	19	18	17	16
Reserved							COUNTFLAG
15	14	13	12	11	10	9	8
Reserved							
7	6	5	4	3	2	1	0
Reserved					CLKSRC	TICKINT	ENABLE

Bits	Description	
[31:17]	Reserved	Reserved
[16]	COUNTFLAG	Returns 1 if timer counted to 0 since last time this register was read. COUNTFLAG is set by a count transition from 1 to 0. COUNTFLAG is cleared on read or by a write to the Current Value register.
[15:3]	Reserved	Reserved
[2]	CLKSRC	1 = Core clock used for SysTick. 0 = Clock source is (optional) external reference clock
[1]	TICKINT	1 = Counting down to 0 will cause the SysTick exception to be pended. Clearing the SysTick Current Value register by a register write in software will not cause SysTick to be pended. 0 = Counting down to 0 does not cause the SysTick exception to be pended. Software can use COUNTFLAG to determine if a count to 0 has occurred.
[0]	ENABLE	1 = Counter will operate in a multi-shot manner 0 = Counter Disabled



SysTick Reload Value Register (SYST_RVR)

Register	Offset	R/W	Description	Reset Value
SYST_RVR	SCS_BA+0x14	R/W	SysTick Reload Value Register	0xFFFF_FFFF

31	30	29	28	27	26	25	24
Reserved							
23	22	21	20	19	18	17	16
RELOAD[23:16]							
15	14	13	12	11	10	9	8
RELOAD[15:8]							
7	6	5	4	3	2	1	0
RELOAD[7:0]							

Bits	Description	
[31:24]	Reserved	Reserved
[23:0]	RELOAD	Value to load into the Current Value register when the counter reaches 0.



SysTick Current Value Register (SYST_CVR)

Register	Offset	R/W	Description	Reset Value
SYST_CVR	SCS_BA+0x18	R/W	SysTick Current Value Register	0xFFFF_XXXX

31	30	29	28	27	26	25	24
Reserved							
23	22	21	20	19	18	17	16
CURRENT [23:16]							
15	14	13	12	11	10	9	8
CURRENT [15:8]							
7	6	5	4	3	2	1	0
CURRENT[7:0]							

Bits	Description	
[31:24]	Reserved	Reserved
[23:0]	CURRENT	Current counter value. This is the value of the counter at the time it is sampled. The counter does not provide read-modify-write protection. The register is write-clear. A software write of any value will clear the register to 0.

5.2.7 Nested Vectored Interrupt Controller (NVIC)

The Cortex-M0 provides an interrupt controller as an integral part of the exception mode, named as “Nested Vectored Interrupt Controller (NVIC)”. It is closely coupled to the processor kernel and provides following features:

- Nested and Vectored interrupt support
- Automatic processor state saving and restoration
- Reduced and deterministic interrupt latency

The NVIC prioritizes and handles all supported exceptions. All exceptions are handled in “Handler Mode”. This NVIC architecture supports 32 (IRQ[31:0]) discrete interrupts with 4 levels of priority. All of the interrupts and most of the system exceptions can be configured to different priority levels. When an interrupt occurs, the NVIC will compare the priority of the new interrupt to the current running one’s priority. If the priority of the new interrupt is higher than the current one, the new interrupt handler will override the current handler.

When any interrupts is accepted, the starting address of the interrupt service routine (ISR) is fetched from a vector table in memory. There is no need to determine which interrupt is accepted and branch to the starting address of the correlated ISR by software. While the starting address is fetched, NVIC will also automatically save processor state including the registers “PC, PSR, LR, R0~R3, R12” to the stack. At the end of the ISR, the NVIC will restore the mentioned registers from stack and resume the normal execution. Thus it will take less and deterministic time to process the interrupt request.

The NVIC supports “Tail Chaining” which handles back-to-back interrupts efficiently without the overhead of states saving and restoration and therefore reduces delay time in switching to pending ISR at the end of current ISR. The NVIC also supports “Late Arrival” which improves the efficiency of concurrent ISRs. When a higher priority interrupt request occurs before the current ISR starts to execute (at the stage of state saving and starting address fetching), the NVIC will give priority to the higher one without delay penalty. Thus it advances the real-time capability.

For more detailed information, please refer to the documents “ARM® Cortex™-M0 Technical Reference Manual” and “ARM® v6-M Architecture Reference Manual”.



5.2.7.1 Exception Model and System Interrupt Map

Table 5-2 lists the exception model supported by NuMicro™ NUC100 Series. Software can set four levels of priority on some of these exceptions as well as on all interrupts. The highest user-configurable priority is denoted as “0” and the lowest priority is denoted as “3”. The default priority of all the user-configurable interrupts is “0”. Note that priority “0” is treated as the fourth priority on the system, after three system exceptions “Reset”, “NMI” and “Hard Fault”.

Exception Name	Vector Number	Priority
Reset	1	-3
NMI	2	-2
Hard Fault	3	-1
Reserved	4 ~ 10	Reserved
SVCAll	11	Configurable
Reserved	12 ~ 13	Reserved
PendSV	14	Configurable
SysTick	15	Configurable
Interrupt (IRQ0 ~ IRQ31)	16 ~ 47	Configurable

Table 5-2 Exception Model

Vector Number	Interrupt Number (Bit in Interrupt Registers)	Interrupt Name	Source IP	Interrupt description
0 ~ 15	-	-	-	System exceptions
16	0	BOD_OUT	Brown-out	Brown-out low voltage detected interrupt
17	1	WDT_INT	WDT	Watchdog Timer interrupt
18	2	EINT0	GPIO	External signal interrupt from PB.14 pin
19	3	EINT1	GPIO	External signal interrupt from PB.15 pin
20	4	GPAB_INT	GPIO	External signal interrupt from PA[15:0]/PB[13:0]
21	5	GPCDE_INT	GPIO	External interrupt from PC[15:0]/PD[15:0]/PE[15:0]
22	6	PWMA_INT	PWM0~3	PWM0, PWM1, PWM2 and PWM3 interrupt
23	7	PWMB_INT	PWM4~7	PWM4, PWM5, PWM6 and PWM7 interrupt
24	8	TMR0_INT	TMR0	Timer 0 interrupt
25	9	TMR1_INT	TMR1	Timer 1 interrupt
26	10	TMR2_INT	TMR2	Timer 2 interrupt



27	11	TMR3_INT	TMR3	Timer 3 interrupt
28	12	UART02_INT	UART0/2	UART0 and UART2 interrupt
29	13	UART1_INT	UART1	UART1 interrupt
30	14	SPI0_INT	SPI0	SPI0 interrupt
31	15	SPI1_INT	SPI1	SPI1 interrupt
32	16	SPI2_INT	SPI2	SPI2 interrupt
33	17	SPI3_INT	SPI3	SPI3 interrupt
34	18	I2C0_INT	I ² C0	I ² C0 interrupt
35	19	I2C1_INT	I ² C1	I ² C1 interrupt
36	20	CAN0_INT	CAN0	CAN0 interrupt
37	21	Reserved	Reserved	Reserved
38	22	Reserved	Reserved	Reserved
39	23	USB_INT	USBD	USB 2.0 FS Device interrupt
40	24	PS2_INT	PS/2	PS/2 interrupt
41	25	ACMP_INT	ACMP	Analog Comparator-0 or Comaprator-1 interrupt
42	26	PDMA_INT	PDMA	PDMA interrupt
43	27	I2S_INT	I ² S	I ² S interrupt
44	28	PWRWU_INT	CLKC	Clock controller interrupt for chip wake-up from Power-down state
45	29	ADC_INT	ADC	ADC interrupt
46	30	Reserved	Reserved	Reserved
47	31	RTC_INT	RTC	Real time clock interrupt

Table 5-3 System Interrupt Map



5.2.7.2 Vector Table

When any interrupts is accepted, the processor will automatically fetch the starting address of the interrupt service routine (ISR) from a vector table in memory. For ARMv6-M, the vector table base address is fixed at 0x00000000. The vector table contains the initialization value for the stack pointer on reset, and the entry point addresses for all exception handlers. The vector number on previous page defines the order of entries in the vector table associated with exception handler entry as illustrated in previous section.

Vector Table Word Offset	Description
0	SP_main – The Main stack pointer
Vector Number	Exception Entry Pointer using that Vector Number

Table 5-4 Vector Table Format

5.2.7.3 Operation Description

NVIC interrupts can be enabled and disabled by writing to their corresponding Interrupt Set-Enable or Interrupt Clear-Enable register bit-field. The registers use a write-1-to-enable and write-1-to-clear policy, both registers reading back the current enabled state of the corresponding interrupts. When an interrupt is disabled, interrupt assertion will cause the interrupt to become Pending, however, the interrupt will not activate. If an interrupt is Active when it is disabled, it remains in its Active state until cleared by reset or an exception return. Clearing the enable bit prevents new activations of the associated interrupt.

NVIC interrupts can be pended/un-pended using a complementary pair of registers to those used to enable/disable the interrupts, named the Set-Pending Register and Clear-Pending Register respectively. The registers use a write-1-to-enable and write-1-to-clear policy, both registers reading back the current pended state of the corresponding interrupts. The Clear-Pending Register has no effect on the execution status of an Active interrupt.

NVIC interrupts are prioritized by updating an 8-bit field within a 32-bit register (each register supporting four interrupts).

The general registers associated with the NVIC are all accessible from a block of memory in the System Control Space and will be described in next section.



5.2.7.4 NVIC Control Registers

R: read only, W: write only, R/W: both read and write

Register	Offset	R/W	Description	Reset Value
SCS Base Address:				
SCS_BA = 0xE000_E000				
NVIC_ISER	SCS_BA+0x100	R/W	IRQ0 ~ IRQ31 Set-Enable Control Register	0x0000_0000
NVIC_ICER	SCS_BA+0x180	R/W	IRQ0 ~ IRQ31 Clear-Enable Control Register	0x0000_0000
NVIC_ISPR	SCS_BA+0x200	R/W	IRQ0 ~ IRQ31 Set-Pending Control Register	0x0000_0000
NVIC_ICPR	SCS_BA+0x280	R/W	IRQ0 ~ IRQ31 Clear-Pending Control Register	0x0000_0000
NVIC_IPR0	SCS_BA+0x400	R/W	IRQ0 ~ IRQ3 Interrupt Priority Control Register	0x0000_0000
NVIC_IPR1	SCS_BA+0x404	R/W	IRQ4 ~ IRQ7 Interrupt Priority Control Register	0x0000_0000
NVIC_IPR2	SCS_BA+0x408	R/W	IRQ8 ~ IRQ11 Interrupt Priority Control Register	0x0000_0000
NVIC_IPR3	SCS_BA+0x40C	R/W	IRQ12 ~ IRQ15 Interrupt Priority Control Register	0x0000_0000
NVIC_IPR4	SCS_BA+0x410	R/W	IRQ16 ~ IRQ19 Interrupt Priority Control Register	0x0000_0000
NVIC_IPR5	SCS_BA+0x414	R/W	IRQ20 ~ IRQ23 Interrupt Priority Control Register	0x0000_0000
NVIC_IPR6	SCS_BA+0x418	R/W	IRQ24 ~ IRQ27 Interrupt Priority Control Register	0x0000_0000
NVIC_IPR7	SCS_BA+0x41C	R/W	IRQ28 ~ IRQ31 Interrupt Priority Control Register	0x0000_0000



IRQ0 ~ IRQ31 Set-Enable Control Register (NVIC_IUSER)

Register	Offset	R/W	Description	Reset Value
NVIC_IUSER	SCS_BA+0x100	R/W	IRQ0 ~ IRQ31 Set-Enable Control Register	0x0000_0000

31	30	29	28	27	26	25	24
SETENA[31:24]							
23	22	21	20	19	18	17	16
SETENA [23:16]							
15	14	13	12	11	10	9	8
SETENA [15:8]							
7	6	5	4	3	2	1	0
SETENA[7:0]							

Bits	Description
[31:0]	<p>SETENA</p> <p>Enable one or more interrupts within a group of 32. Each bit represents an interrupt number from IRQ0 ~ IRQ31 (Vector number from 16 ~ 47).</p> <p>Writing 1 will enable the associated interrupt.</p> <p>Writing 0 has no effect.</p> <p>The register reads back with the current enable state.</p>



IRQ0 ~ IRQ31 Clear-Enable Control Register (NVIC_ICER)

Register	Offset	R/W	Description	Reset Value
NVIC_ICER	SCS_BA+0x180	R/W	IRQ0 ~ IRQ31 Clear-Enable Control Register	0x0000_0000

31	30	29	28	27	26	25	24
CLRENA[31:24]							
23	22	21	20	19	18	17	16
CLRENA [23:16]							
15	14	13	12	11	10	9	8
CLRENA [15:8]							
7	6	5	4	3	2	1	0
CLRENA[7:0]							

Bits	Description
[31:0]	<p>CLRENA</p> <p>Disable one or more interrupts within a group of 32. Each bit represents an interrupt number from IRQ0 ~ IRQ31 (Vector number from 16 ~ 47).</p> <p>Writing 1 will disable the associated interrupt.</p> <p>Writing 0 has no effect.</p> <p>The register reads back with the current enable state.</p>



IRQ0 ~ IRQ31 Set-Pending Control Register (NVIC_ISPR)

Register	Offset	R/W	Description	Reset Value
NVIC_ISPR	SCS_BA+0x200	R/W	IRQ0 ~ IRQ31 Set-Pending Control Register	0x0000_0000

31	30	29	28	27	26	25	24
SETPEND[31:24]							
23	22	21	20	19	18	17	16
SETPEND [23:16]							
15	14	13	12	11	10	9	8
SETPEND [15:8]							
7	6	5	4	3	2	1	0
SETPEND [7:0]							

Bits	Description
[31:0]	<p>SETPEND</p> <p>Writing 1 to a bit to set pending state of the associated interrupt under software control. Each bit represents an interrupt number from IRQ0 ~ IRQ31 (Vector number from 16 ~ 47).</p> <p>Writing 0 has no effect.</p> <p>The register reads back with the current pending state.</p>



IRQ0 ~ IRQ31 Clear-Pending Control Register (NVIC_ICPR)

Register	Offset	R/W	Description	Reset Value
NVIC_ICPR	SCS_BA+0x280	R/W	IRQ0 ~ IRQ31 Clear-Pending Control Register	0x0000_0000

31	30	29	28	27	26	25	24
CLRPEND [31:24]							
23	22	21	20	19	18	17	16
CLRPEND [23:16]							
15	14	13	12	11	10	9	8
CLRPEND [15:8]							
7	6	5	4	3	2	1	0
CLRPEND [7:0]							

Bits	Description
[31:0]	<p>CLRPEND</p> <p>Writing 1 to a bit to remove the pending state of associated interrupt under software control. Each bit represents an interrupt number from IRQ0 ~ IRQ31 (Vector number from 16 ~ 47).</p> <p>Writing 0 has no effect.</p> <p>The register reads back with the current pending state.</p>



IRQ0 ~ IRQ3 Interrupt Priority Register (NVIC_IPRO)

Register	Offset	R/W	Description	Reset Value
NVIC_IPRO	SCS_BA+0x400	R/W	IRQ0 ~ IRQ3 Interrupt Priority Control Register	0x0000_0000

31	30	29	28	27	26	25	24
PRI_3		Reserved					
23	22	21	20	19	18	17	16
PRI_2		Reserved					
15	14	13	12	11	10	9	8
PRI_1		Reserved					
7	6	5	4	3	2	1	0
PRI_0		Reserved					

Bits	Description	
[31:30]	PRI_3	Priority of IRQ3 "0" denotes the highest priority and "3" denotes lowest priority
[29:24]	Reserved	Reserved
[23:22]	PRI_2	Priority of IRQ2 "0" denotes the highest priority and "3" denotes lowest priority
[21:16]	Reserved	Reserved
[15:14]	PRI_1	Priority of IRQ1 "0" denotes the highest priority and "3" denotes lowest priority
[13:8]	Reserved	Reserved
[7:6]	PRI_0	Priority of IRQ0 "0" denotes the highest priority and "3" denotes lowest priority
[5:0]	Reserved	Reserved



IRQ4 ~ IRQ7 Interrupt Priority Register (NVIC IPR1)

Register	Offset	R/W	Description	Reset Value
NVIC_IPR1	SCS_BA+0x404	R/W	IRQ4 ~ IRQ7 Interrupt Priority Control Register	0x0000_0000

31	30	29	28	27	26	25	24
PRI_7		Reserved					
23	22	21	20	19	18	17	16
PRI_6		Reserved					
15	14	13	12	11	10	9	8
PRI_5		Reserved					
7	6	5	4	3	2	1	0
PRI_4		Reserved					

Bits	Description	
[31:30]	PRI_7	Priority of IRQ7 "0" denotes the highest priority and "3" denotes lowest priority
[29:24]	Reserved	Reserved
[23:22]	PRI_6	Priority of IRQ6 "0" denotes the highest priority and "3" denotes lowest priority
[21:16]	Reserved	Reserved
[15:14]	PRI_5	Priority of IRQ5 "0" denotes the highest priority and "3" denotes lowest priority
[13:8]	Reserved	Reserved
[7:6]	PRI_4	Priority of IRQ4 "0" denotes the highest priority and "3" denotes lowest priority
[5:0]	Reserved	Reserved



IRQ8 ~ IRQ11 Interrupt Priority Register (NVIC_IPR2)

Register	Offset	R/W	Description	Reset Value
NVIC_IPR2	SCS_BA+0x408	R/W	IRQ8 ~ IRQ11 Interrupt Priority Control Register	0x0000_0000

31	30	29	28	27	26	25	24
PRI_11		Reserved					
23	22	21	20	19	18	17	16
PRI_10		Reserved					
15	14	13	12	11	10	9	8
PRI_9		Reserved					
7	6	5	4	3	2	1	0
PRI_8		Reserved					

Bits	Description	
[31:30]	PRI_11	Priority of IRQ11 "0" denotes the highest priority and "3" denotes lowest priority
[29:24]	Reserved	Reserved
[23:22]	PRI_10	Priority of IRQ10 "0" denotes the highest priority and "3" denotes lowest priority
[21:16]	Reserved	Reserved
[15:14]	PRI_9	Priority of IRQ9 "0" denotes the highest priority and "3" denotes lowest priority
[13:8]	Reserved	Reserved
[7:6]	PRI_8	Priority of IRQ8 "0" denotes the highest priority and "3" denotes lowest priority
[5:0]	Reserved	Reserved



IRQ12 ~ IRQ15 Interrupt Priority Register (NVIC_IPR3)

Register	Offset	R/W	Description	Reset Value
NVIC_IPR3	SCS_BA+0x40C	R/W	IRQ12 ~ IRQ15 Interrupt Priority Control Register	0x0000_0000

31	30	29	28	27	26	25	24
PRI_15		Reserved					
23	22	21	20	19	18	17	16
PRI_14		Reserved					
15	14	13	12	11	10	9	8
PRI_13		Reserved					
7	6	5	4	3	2	1	0
PRI_12		Reserved					

Bits	Description	
[31:30]	PRI_15	Priority of IRQ15 "0" denotes the highest priority and "3" denotes lowest priority
[29:24]	Reserved	Reserved
[23:22]	PRI_14	Priority of IRQ14 "0" denotes the highest priority and "3" denotes lowest priority
[21:16]	Reserved	Reserved
[15:14]	PRI_13	Priority of IRQ13 "0" denotes the highest priority and "3" denotes lowest priority
[13:8]	Reserved	Reserved
[7:6]	PRI_12	Priority of IRQ12 "0" denotes the highest priority and "3" denotes lowest priority
[5:0]	Reserved	Reserved



IRQ16 ~ IRQ19 Interrupt Priority Register (NVIC_IPR4)

Register	Offset	R/W	Description	Reset Value
NVIC_IPR4	SCS_BA+0x410	R/W	IRQ16 ~ IRQ19 Interrupt Priority Control Register	0x0000_0000

31	30	29	28	27	26	25	24
PRI_19		Reserved					
23	22	21	20	19	18	17	16
PRI_18		Reserved					
15	14	13	12	11	10	9	8
PRI_17		Reserved					
7	6	5	4	3	2	1	0
PRI_16		Reserved					

Bits	Description	
[31:30]	PRI_19	Priority of IRQ19 "0" denotes the highest priority and "3" denotes lowest priority
[29:24]	Reserved	Reserved
[23:22]	PRI_18	Priority of IRQ18 "0" denotes the highest priority and "3" denotes lowest priority
[21:16]	Reserved	Reserved
[15:14]	PRI_17	Priority of IRQ17 "0" denotes the highest priority and "3" denotes lowest priority
[13:8]	Reserved	Reserved
[7:6]	PRI_16	Priority of IRQ16 "0" denotes the highest priority and "3" denotes lowest priority
[5:0]	Reserved	Reserved



IRQ20 ~ IRQ23 Interrupt Priority Register (NVIC_IPR5)

Register	Offset	R/W	Description	Reset Value
NVIC_IPR5	SCS_BA+0x414	R/W	IRQ20 ~ IRQ23 Interrupt Priority Control Register	0x0000_0000

31	30	29	28	27	26	25	24
PRI_23		Reserved					
23	22	21	20	19	18	17	16
PRI_22		Reserved					
15	14	13	12	11	10	9	8
PRI_21		Reserved					
7	6	5	4	3	2	1	0
PRI_20		Reserved					

Bits	Description	
[31:30]	PRI_23	Priority of IRQ23 "0" denotes the highest priority and "3" denotes lowest priority
[29:24]	Reserved	Reserved
[23:22]	PRI_22	Priority of IRQ22 "0" denotes the highest priority and "3" denotes lowest priority
[21:16]	Reserved	Reserved
[15:14]	PRI_21	Priority of IRQ21 "0" denotes the highest priority and "3" denotes lowest priority
[13:8]	Reserved	Reserved
[7:6]	PRI_20	Priority of IRQ20 "0" denotes the highest priority and "3" denotes lowest priority
[5:0]	Reserved	Reserved



IRQ24 ~ IRQ27 Interrupt Priority Register (NVIC_IPR6)

Register	Offset	R/W	Description	Reset Value
NVIC_IPR6	SCS_BA+0x418	R/W	IRQ24 ~ IRQ27 Interrupt Priority Control Register	0x0000_0000

31	30	29	28	27	26	25	24
PRI_27		Reserved					
23	22	21	20	19	18	17	16
PRI_26		Reserved					
15	14	13	12	11	10	9	8
PRI_25		Reserved					
7	6	5	4	3	2	1	0
PRI_24		Reserved					

Bits	Description	
[31:30]	PRI_27	Priority of IRQ27 "0" denotes the highest priority and "3" denotes lowest priority
[29:24]	Reserved	Reserved
[23:22]	PRI_26	Priority of IRQ26 "0" denotes the highest priority and "3" denotes lowest priority
[21:16]	Reserved	Reserved
[15:14]	PRI_25	Priority of IRQ25 "0" denotes the highest priority and "3" denotes lowest priority
[13:8]	Reserved	Reserved
[7:6]	PRI_24	Priority of IRQ24 "0" denotes the highest priority and "3" denotes lowest priority
[5:0]	Reserved	Reserved



IRQ28 ~ IRQ31 Interrupt Priority Register (NVIC_IPR7)

Register	Offset	R/W	Description	Reset Value
NVIC_IPR7	SCS_BA+0x41C	R/W	IRQ28 ~ IRQ31 Interrupt Priority Control Register	0x0000_0000

31	30	29	28	27	26	25	24
PRI_31		Reserved					
23	22	21	20	19	18	17	16
PRI_30		Reserved					
15	14	13	12	11	10	9	8
PRI_29		Reserved					
7	6	5	4	3	2	1	0
PRI_28		Reserved					

Bits	Description	
[31:30]	PRI_31	Priority of IRQ31 "0" denotes the highest priority and "3" denotes lowest priority
[29:24]	Reserved	Reserved
[23:22]	PRI_30	Priority of IRQ30 "0" denotes the highest priority and "3" denotes lowest priority
[21:16]	Reserved	Reserved
[15:14]	PRI_29	Priority of IRQ29 "0" denotes the highest priority and "3" denotes lowest priority
[13:8]	Reserved	Reserved
[7:6]	PRI_28	Priority of IRQ28 "0" denotes the highest priority and "3" denotes lowest priority
[5:0]	Reserved	Reserved



5.2.7.5 Interrupt Source Control Registers

Besides the interrupt control registers associated with the NVIC, the NuMicro™ NUC100 Series also implement some specific control registers to facilitate the interrupt functions, including “interrupt source identification”, “NMI source selection” and “interrupt test mode”. They are described as below.

R: read only, **W:** write only, **R/W:** both read and write

Register	Offset	R/W	Description	Reset Value
INT Base Address:				
INT_BA = 0x5000_0300				
IRQ0_SRC	INT_BA+0x00	R	IRQ0 (BOD) interrupt source identity	0xFFFF_FFFF
IRQ1_SRC	INT_BA+0x04	R	IRQ1 (WDT) interrupt source identity	0xFFFF_FFFF
IRQ2_SRC	INT_BA+0x08	R	IRQ2 (EINT0) interrupt source identity	0xFFFF_FFFF
IRQ3_SRC	INT_BA+0x0C	R	IRQ3 (EINT1) interrupt source identity	0xFFFF_FFFF
IRQ4_SRC	INT_BA+0x10	R	IRQ4 (GPA/B) interrupt source identity	0xFFFF_FFFF
IRQ5_SRC	INT_BA+0x14	R	IRQ5 (GPC/D/E) interrupt source identity	0xFFFF_FFFF
IRQ6_SRC	INT_BA+0x18	R	IRQ6 (PWMA) interrupt source identity	0xFFFF_FFFF
IRQ7_SRC	INT_BA+0x1C	R	IRQ7 (PWMB) interrupt source identity	0xFFFF_FFFF
IRQ8_SRC	INT_BA+0x20	R	IRQ8 (TMR0) interrupt source identity	0xFFFF_FFFF
IRQ9_SRC	INT_BA+0x24	R	IRQ9 (TMR1) interrupt source identity	0xFFFF_FFFF
IRQ10_SRC	INT_BA+0x28	R	IRQ10 (TMR2) interrupt source identity	0xFFFF_FFFF
IRQ11_SRC	INT_BA+0x2C	R	IRQ11 (TMR3) interrupt source identity	0xFFFF_FFFF
IRQ12_SRC	INT_BA+0x30	R	IRQ12 (UART0) interrupt source identity	0xFFFF_FFFF
IRQ13_SRC	INT_BA+0x34	R	IRQ13 (UART1) interrupt source identity	0xFFFF_FFFF
IRQ14_SRC	INT_BA+0x38	R	IRQ14 (SPI0) interrupt source identity	0xFFFF_FFFF
IRQ15_SRC	INT_BA+0x3C	R	IRQ15 (SPI1) interrupt source identity	0xFFFF_FFFF
IRQ16_SRC	INT_BA+0x40	R	IRQ16 (SPI2) interrupt source identity	0xFFFF_FFFF
IRQ17_SRC	INT_BA+0x44	R	IRQ17 (SPI3) interrupt source identity	0xFFFF_FFFF
IRQ18_SRC	INT_BA+0x48	R	IRQ18 (I ² C0) interrupt source identity	0xFFFF_FFFF
IRQ19_SRC	INT_BA+0x4C	R	IRQ19 (I ² C1) interrupt source identity	0xFFFF_FFFF
IRQ20_SRC	INT_BA+0x50	R	IRQ20 (CAN0) interrupt source identity	0xFFFF_FFFF
IRQ21_SRC	INT_BA+0x54	R	IRQ21 (Reserved) interrupt source identity	0xFFFF_FFFF
IRQ22_SRC	INT_BA+0x58	R	IRQ22 (Reserved) interrupt source identity	0xFFFF_FFFF



IRQ23_SRC	INT_BA+0x5C	R	IRQ23 (USBD) interrupt source identity	0xFFFF_FFFF
IRQ24_SRC	INT_BA+0x60	R	IRQ24 (PS/2) interrupt source identity	0xFFFF_FFFF
IRQ25_SRC	INT_BA+0x64	R	IRQ25 (ACMP) interrupt source identity	0xFFFF_FFFF
IRQ26_SRC	INT_BA+0x68	R	IRQ26 (PDMA) interrupt source identity	0xFFFF_FFFF
IRQ27_SRC	INT_BA+0x6C	R	IRQ27 (I ² S) interrupt source identity	0xFFFF_FFFF
IRQ28_SRC	INT_BA+0x70	R	IRQ28 (PWRWU) interrupt source identity	0xFFFF_FFFF
IRQ29_SRC	INT_BA+0x74	R	IRQ29 (ADC) interrupt source identity	0xFFFF_FFFF
IRQ30_SRC	INT_BA+0x78	R	IRQ30 (Reserved) interrupt source identity	0xFFFF_FFFF
IRQ31_SRC	INT_BA+0x7C	R	IRQ31 (RTC) interrupt source identity	0xFFFF_FFFF
NMI_SEL	INT_BA+0x80	R/W	NMI source interrupt select control register	0x0000_0000
MCU_IRQ	INT_BA+0x84	R/W	MCU IRQ Number identity register	0x0000_0000



Interrupt Source Identity Register (IRQn_SRC)

Register	Offset	R/W	Description	Reset Value
IRQ0_SRC	INT_BA+0x00	R	IRQ0 (BOD) interrupt source identity	0xFFFF_XXXX
IRQ1_SRC	INT_BA+0x04	R	IRQ1 (WDT) interrupt source identity	0xFFFF_XXXX
IRQ2_SRC	INT_BA+0x08	R	IRQ2 (EINT0) interrupt source identity	0xFFFF_XXXX
IRQ3_SRC	INT_BA+0x0C	R	IRQ3 (EINT1) interrupt source identity	0xFFFF_XXXX
IRQ4_SRC	INT_BA+0x10	R	IRQ4 (GPA/B) interrupt source identity	0xFFFF_XXXX
IRQ5_SRC	INT_BA+0x14	R	IRQ5 (GPC/D/E) interrupt source identity	0xFFFF_XXXX
IRQ6_SRC	INT_BA+0x18	R	IRQ6 (PWMA) interrupt source identity	0xFFFF_XXXX
IRQ7_SRC	INT_BA+0x1C	R	IRQ7 (PWMB) interrupt source identity	0xFFFF_XXXX
IRQ8_SRC	INT_BA+0x20	R	IRQ8 (TMR0) interrupt source identity	0xFFFF_XXXX
IRQ9_SRC	INT_BA+0x24	R	IRQ9 (TMR1) interrupt source identity	0xFFFF_XXXX
IRQ10_SRC	INT_BA+0x28	R	IRQ10 (TMR2) interrupt source identity	0xFFFF_XXXX
IRQ11_SRC	INT_BA+0x2C	R	IRQ11 (TMR3) interrupt source identity	0xFFFF_XXXX
IRQ12_SRC	INT_BA+0x30	R	IRQ12 (UART0) interrupt source identity	0xFFFF_XXXX
IRQ13_SRC	INT_BA+0x34	R	IRQ13 (UART1) interrupt source identity	0xFFFF_XXXX
IRQ14_SRC	INT_BA+0x38	R	IRQ14 (SPI0) interrupt source identity	0xFFFF_XXXX
IRQ15_SRC	INT_BA+0x3C	R	IRQ15 (SPI1) interrupt source identity	0xFFFF_XXXX
IRQ16_SRC	INT_BA+0x40	R	IRQ16 (SPI2) interrupt source identity	0xFFFF_XXXX
IRQ17_SRC	INT_BA+0x44	R	IRQ17 (SPI3) interrupt source identity	0xFFFF_XXXX
IRQ18_SRC	INT_BA+0x48	R	IRQ18 (I ² C0) interrupt source identity	0xFFFF_XXXX
IRQ19_SRC	INT_BA+0x4C	R	IRQ19 (I ² C1) interrupt source identity	0xFFFF_XXXX
IRQ20_SRC	INT_BA+0x50	R	IRQ20 (CAN0) interrupt source identity	0xFFFF_XXXX
IRQ21_SRC	INT_BA+0x54	R	IRQ21 (Reserved) interrupt source identity	0xFFFF_XXXX
IRQ22_SRC	INT_BA+0x58	R	IRQ22 (Reserved) interrupt source identity	0xFFFF_XXXX
IRQ23_SRC	INT_BA+0x5C	R	IRQ23 (USBD) interrupt source identity	0xFFFF_XXXX
IRQ24_SRC	INT_BA+0x60	R	IRQ24 (PS/2) interrupt source identity	0xFFFF_XXXX
IRQ25_SRC	INT_BA+0x64	R	IRQ25 (ACMP) interrupt source identity	0xFFFF_XXXX
IRQ26_SRC	INT_BA+0x68	R	IRQ26 (PDMA) interrupt source identity	0xFFFF_XXXX
IRQ27_SRC	INT_BA+0x6C	R	IRQ27 (I ² S) interrupt source identity	0xFFFF_XXXX
IRQ28_SRC	INT_BA+0x70	R	IRQ28 (PWRWU) interrupt source identity	0xFFFF_XXXX



IRQ29_SRC	INT_BA+0x74	R	IRQ29 (ADC) interrupt source identity	0XXXXX_XXXX
IRQ30_SRC	INT_BA+0x78	R	IRQ30 (Reserved) interrupt source identity	0XXXXX_XXXX
IRQ31_SRC	INT_BA+0x7C	R	IRQ31 (RTC) interrupt source identity	0XXXXX_XXXX

31	30	29	28	27	26	25	24
Reserved							
23	22	21	20	19	18	17	16
Reserved							
15	14	13	12	11	10	9	8
Reserved							
7	6	5	4	3	2	1	0
Reserved				INT_SRC[3]	INT_SRC[2:0]		

Bits	Description	
[31:4]	-	Reserved
[3:0]	INT_SRC	Interrupt Source Define the interrupt sources for interrupt event.

Bits	Address	INT-No.	Description
[2:0]	INT_BA+0x00	0	Bit2: 0 Bit1: 0 Bit0: BOD_INT
[2:0]	INT_BA+0x04	1	Bit2: 0 Bit1: 0 Bit0: WDT_INT
[2:0]	INT_BA+0x08	2	Bit2: 0 Bit1: 0 Bit0: EINT0 – external interrupt 0 from PB.14
[2:0]	INT_BA+0x0C	3	Bit2: 0 Bit1: 0 Bit0: EINT1 – external interrupt 1 from PB.15
[2:0]	INT_BA+0x10	4	Bit2: 0 Bit1: GPB_INT Bit0: GPA_INT
[2:0]	INT_BA+0x14	5	Bit2: GPE_INT



			Bit1: GPD_INT Bit0: GPC_INT
[3:0]	INT_BA+0x18	6	Bit3: PWM3_INT Bit2: PWM2_INT Bit1: PWM1_INT Bit0: PWM0_INT
[3:0]	INT_BA+0x1C	7	Bit3: PWM7_INT Bit2: PWM6_INT Bit1: PWM5_INT Bit0: PWM4_INT
[2:0]	INT_BA+0x20	8	Bit2: 0 Bit1: 0 Bit0: TMR0_INT
[2:0]	INT_BA+0x24	9	Bit2: 0 Bit1: 0 Bit0: TMR1_INT
[2:0]	INT_BA+0x28	10	Bit2: 0 Bit1: 0 Bit0: TMR2_INT
[2:0]	INT_BA+0x2C	11	Bit2: 0 Bit1: 0 Bit0: TMR3_INT
[2:0]	INT_BA+0x30	12	Bit2: 0 Bit1: URT2_INT Bit0: URT0_INT
[2:0]	INT_BA+0x34	13	Bit2: 0 Bit1: 0 Bit0: URT1_INT
[2:0]	INT_BA+0x38	14	Bit2: 0 Bit1: 0 Bit0: SPI0_INT
[2:0]	INT_BA+0x3C	15	Bit2: 0 Bit1: 0 Bit0: SPI1_INT
[2:0]	INT_BA+0x40	16	Bit2: 0 Bit1: 0 Bit0: SPI2_INT
[2:0]	INT_BA+0x44	17	Bit2: 0 Bit1: 0



			Bit0: SPI3_INT
[2:0]	INT_BA+0x48	18	Bit2: 0 Bit1: 0 Bit0: I2C0_INT
[2:0]	INT_BA+0x4C	19	Bit2: 0 Bit1: 0 Bit0: I2C1_INT
[2:0]	INT_BA+0x50	20	Bit2: 0 Bit1: 0 Bit0: CAN0_INT
[2:0]	INT_BA+0x54	21	Reserved
[2:0]	INT_BA+0x58	22	Reserved
[2:0]	INT_BA+0x5C	23	Bit2: 0 Bit1: 0 Bit0: USB_INT
[2:0]	INT_BA+0x60	24	Bit2: 0 Bit1: 0 Bit0: PS2_INT
[2:0]	INT_BA+0x64	25	Bit2: 0 Bit1: 0 Bit0: ACMP_INT
[2:0]	INT_BA+0x68	26	Bit2: 0 Bit1: 0 Bit0: PDMA_INT
[2:0]	INT_BA+0x6C	27	Bit2: 0 Bit1: 0 Bit0: I2S_INT
[2:0]	INT_BA+0x70	28	Bit2: 0 Bit1: 0 Bit0: PWRWU_INT
[2:0]	INT_BA+0x74	29	Bit2: 0 Bit1: 0 Bit0: ADC_INT
[2:0]	INT_BA+0x78	30	Reserved
[2:0]	INT_BA+0x7C	31	Bit2: 0 Bit1: 0 Bit0: RTC_INT



NMI Interrupt Source Select Control Register (NMI_SEL)

Register	Offset	R/W	Description	Reset Value
NMI_SEL	INT_BA+0x80	R/W	NMI source interrupt select control register	0x0000_0000

31	30	29	28	27	26	25	24
Reserved							
23	22	21	20	19	18	17	16
Reserved							
15	14	13	12	11	10	9	8
Reserved							NMI_EN
7	6	5	4	3	2	1	0
Reserved			NMI_SEL[4:0]				

Bits	Description	
[31:8]	Reserved	Reserved
[8]	NMI_EN	<p>NMI Interrupt Enable (Write-protection Bit)</p> <p>1 = NMI interrupt Enabled</p> <p>0 = NMI interrupt Disabled</p> <p>This bit is the protected bit, which means programming this needs to write "59h", "16h", "88h" to address 0x5000_0100 to disable register protection. Refer to the register REGWRPROT at address GCR_BA+0x100</p>
[7:5]	Reserved	Reserved
[4:0]	NMI_SEL	<p>NMI Interrupt Source Selection</p> <p>The NMI interrupt to Cortex-M0 can be selected from one of the peripheral interrupt by setting NMI_SEL.</p>



MCU Interrupt Request Source Register (MCU_IRQ)

Register	Offset	R/W	Description	Reset Value
MCU_IRQ	INT_BA+0x84	R/W	MCU IRQ Number identity register	0x0000_0000

31	30	29	28	27	26	25	24
MCU_IRQ[31:24]							
23	22	21	20	19	18	17	16
MCU_IRQ[23:16]							
15	14	13	12	11	10	9	8
MCU_IRQ[15:8]							
7	6	5	4	3	2	1	0
MCU_IRQ[7:0]							

Bits	Description
[31:0]	<p>MCU IRQ Source Register</p> <p>The MCU_IRQ collects all the interrupts from the peripherals and generates the synchronous interrupt to Cortex-M0. There are two modes to generate interrupt to Cortex-M0, the normal mode and test mode.</p> <p>The MCU_IRQ collects all interrupts from each peripheral and synchronizes them then interrupts the Cortex-M0.</p> <p>When the MCU_IRQ[n] is 0: Set MCU_IRQ[n] 1 will generate an interrupt to Cortex_M0 NVIC[n].</p> <p>When the MCU_IRQ[n] is 1 (mean an interrupt is assert), set 1 to the MCU_IRQ[n] will clear the interrupt and set MCU_IRQ[n] 0 : no any effect</p>



5.2.8 System Control Register

Cortex-M0 status and operating mode control are managed by System Control Registers. Including CPUID, Cortex-M0 interrupt priority and Cortex-M0 power management can be controlled through these system control register

For more detailed information, please refer to the documents “ARM® Cortex™-M0 Technical Reference Manual” and “ARM® v6-M Architecture Reference Manual”.

R: read only, W: write only, R/W: both read and write

Register	Offset	R/W	Description	Reset Value
SCS Base Address:				
SCS_BA = 0xE000_E000				
CPUID	SCS_BA+0xD00	R	CPUID Register	0x410C_C200
ICSR	SCS_BA+0xD04	R/W	Interrupt Control and State Register	0x0000_0000
AIRCR	SCS_BA+0xD0C	R/W	Application Interrupt and Reset Control Register	0xFA05_0000
SCR	SCS_BA+0xD10	R/W	System Control Register	0x0000_0000
SHPR2	SCS_BA+0xD1C	R/W	System Handler Priority Register 2	0x0000_0000
SHPR3	SCS_BA+0xD20	R/W	System Handler Priority Register 3	0x0000_0000



CPUID Register (CPUID)

Register	Offset	R/W	Description	Reset Value
CPUID	SCS_BA+0xD00	R	CPUID Register	0x410C_C200

31	30	29	28	27	26	25	24
IMPLEMENTER[7:0]							
23	22	21	20	19	18	17	16
Reserved				PART[3:0]			
15	14	13	12	11	10	9	8
PARTNO[11:4]							
7	6	5	4	3	2	1	0
PARTNO[3:0]				REVISION[3:0]			

Bits	Description	
[31:24]	IMPLEMENTER	Implementer code assigned by ARM. (ARM = 0x41)
[23:20]	Reserved	Reserved
[19:16]	PART	Reads as 0xC for ARMv6-M parts
[15:4]	PARTNO	Reads as 0xC20.
[3:0]	REVISION	Reads as 0x0



Interrupt Control State Register (ICSR)

Register	Offset	R/W	Description	Reset Value
ICSR	SCS_BA+0xD04	R/W	Interrupt Control and State Register	0x0000_0000

31	30	29	28	27	26	25	24
NMIPENDSET	Reserved		PENDSVSET	PENDSVCLR	PENDSTSET	PENDSTCLR	Reserved
23	22	21	20	19	18	17	16
ISRPREEMPT	ISRPENDING	Reserved				VECTPENDING[5:4]	
15	14	13	12	11	10	9	8
VECTPENDING[3:0]				Reserved			
7	6	5	4	3	2	1	0
Reserved		VECTACTIVE[5:0]					

Bits	Description
[31]	<p>NMIPENDSET</p> <p>NMI set-pending bit</p> <p>Write:</p> <p>0 = no effect</p> <p>1 = changes NMI exception state to pending.</p> <p>Read:</p> <p>0 = NMI exception is not pending</p> <p>1 = NMI exception is pending.</p> <p>Because NMI is the highest-priority exception, normally the processor enters the NMI exception handler as soon as it detects a write of 1 to this bit. Entering the handler then clears this bit to 0. This means a read of this bit by the NMI exception handler returns 1 only if the NMI signal is reasserted while the processor is executing that handler.</p>
[30:29]	<p>Reserved</p> <p>Reserved</p>
[28]	<p>PENDSVSET</p> <p>PendSV set-pending bit.</p> <p>Write:</p> <p>0 = no effect</p> <p>1 = changes PendSV exception state to pending.</p> <p>Read:</p> <p>0 = PendSV exception is not pending</p> <p>1 = PendSV exception is pending.</p> <p>Writing 1 to this bit is the only way to set the PendSV exception state to pending.</p>
[27]	<p>PENDSVCLR</p> <p>PendSV clear-pending bit.</p> <p>Write:</p> <p>0 = no effect</p>



		<p>1 = removes the pending state from the PendSV exception.</p> <p>This is a write only bit. When you want to clear PENDSV bit, you must “write 0 to PENDSVSET and write 1 to PENDSVCLR” at the same time.</p>
[26]	PENDSTSET	<p>SysTick exception set-pending bit.</p> <p>Write:</p> <p>0 = no effect</p> <p>1 = changes SysTick exception state to pending.</p> <p>Read:</p> <p>0 = SysTick exception is not pending</p> <p>1 = SysTick exception is pending.</p>
[25]	PENDSTCLR	<p>SysTick exception clear-pending bit.</p> <p>Write:</p> <p>0 = no effect</p> <p>1 = removes the pending state from the SysTick exception.</p> <p>This is a write only bit. When you want to clear PENDST bit, you must “write 0 to PENDSTSET and write 1 to PENDSTCLR” at the same time.</p>
[24]	Reserved	Reserved
[23]	ISRPREEMPT	<p>If set, a pending exception will be serviced on exit from the debug halt state.</p> <p>This is a read only bit.</p>
[22]	ISR_PENDING	<p>Interrupt pending flag, excluding NMI and Faults:</p> <p>0 = interrupt not pending</p> <p>1 = interrupt pending.</p> <p>This is a read only bit.</p>
[21:18]	Reserved	Reserved
[17:12]	VECTPENDING	<p>Indicates the exception number of the highest priority pending enabled exception:</p> <p>0 = no pending exceptions</p> <p>Nonzero = the exception number of the highest priority pending enabled exception.</p>
[11:6]	Reserved	Reserved
[5:0]	VECTACTIVE	<p>Contains the active exception number</p> <p>0 = Thread mode</p> <p>Nonzero = The exception number of the currently active exception.</p>



Application Interrupt and Reset Control Register (AIRCR)

Register	Offset	R/W	Description	Reset Value
AIRCR	SCS_BA+0xD0C	R/W	Application Interrupt and Reset Control Register	0xFA05_0000

31	30	29	28	27	26	25	24
VECTORKEY[15:8]							
23	22	21	20	19	18	17	16
VECTORKEY[7:0]							
15	14	13	12	11	10	9	8
Reserved							
7	6	5	4	3	2	1	0
Reserved					SYSRESETR EQ	VECTCLKAC TIVE	Reserved

Bits	Description	
[31:16]	VECTORKEY	When writing this register, this field should be 0x05FA, otherwise the write action will be unpredictable.
[15:3]	Reserved	Reserved
[2]	SYSRESETR EQ	Writing this bit 1 will cause a reset signal to be asserted to the chip to indicate a reset is requested. The bit is a write only bit and self-clears as part of the reset sequence.
[1]	VECTCLRACTIVE	Set this bit to 1 will clear all active state information for fixed and configurable exceptions. The bit is a write only bit and can only be written when the core is halted. Note: It is the debugger's responsibility to re-initialize the stack.
[0]	Reserved	Reserved



System Control Register (SCR)

Register	Offset	R/W	Description	Reset Value
SCR	SCS_BA+0xD10	R/W	System Control Register	0x0000_0000

31	30	29	28	27	26	25	24
Reserved							
23	22	21	20	19	18	17	16
Reserved							
15	14	13	12	11	10	9	8
Reserved							
7	6	5	4	3	2	1	0
Reserved			SEVONPEND	Reserved	SLEEPDEEP	SLEEPONEXIT	Reserved

Bits	Description	
[31:5]	Reserved	Reserved
[4]	SEVONPEND	<p>Send Event on Pending bit:</p> <p>0 = only enabled interrupts or events can wakeup the processor, disabled interrupts are excluded</p> <p>1 = enabled events and all interrupts, including disabled interrupts, can wakeup the processor.</p> <p>When an event or interrupt enters pending state, the event signal wakes up the processor from WFE. If the processor is not waiting for an event, the event is registered and affects the next WFE.</p> <p>The processor also wakes up on execution of an SEV instruction or an external event.</p>
[3]	Reserved	Reserved
[2]	SLEEPDEEP	<p>Controls whether the processor uses sleep or deep sleep as its low power mode:</p> <p>0 = sleep</p> <p>1 = deep sleep</p>
[1]	SLEEPONEXIT	<p>Indicates sleep-on-exit when returning from Handler mode to Thread mode:</p> <p>0 = do not sleep when returning to Thread mode.</p> <p>1 = enter sleep, or deep sleep, on return from an ISR to Thread mode.</p> <p>Setting this bit to 1 enables an interrupt driven application to avoid returning to an empty main application.</p>
[0]	Reserved	Reserved



System Handler Priority Register 2 (SHPR2)

Register	Offset	R/W	Description	Reset Value
SHPR2	SCS_BA+0xD1C	R/W	System Handler Priority Register 2	0x0000_0000

31	30	29	28	27	26	25	24
PRI_11		Reserved					
23	22	21	20	19	18	17	16
Reserved							
15	14	13	12	11	10	9	8
Reserved							
7	6	5	4	3	2	1	0
Reserved							

Bits	Description	
[31:30]	PRI_11	Priority of system handler 11 – SVCall “0” denotes the highest priority and “3” denotes lowest priority
[29:0]	Reserved	Reserved



System Handler Priority Register 3 (SHPR3)

Register	Offset	R/W	Description	Reset Value
SHPR3	SCS_BA+0xD20	R/W	System Handler Priority Register 3	0x0000_0000

31	30	29	28	27	26	25	24
PRI_15		Reserved					
23	22	21	20	19	18	17	16
PRI_14		Reserved					
15	14	13	12	11	10	9	8
Reserved							
7	6	5	4	3	2	1	0
Reserved							

Bits	Description	
[31:30]	PRI_15	Priority of system handler 15 – SysTick “0” denotes the highest priority and “3” denotes lowest priority
[29:24]	Reserved	Reserved
[23:22]	PRI_14	Priority of system handler 14 – PendSV “0” denotes the highest priority and “3” denotes lowest priority
[21:0]	Reserved	Reserved



5.3 Clock Controller

5.3.1 Overview

The clock controller generates the clocks for the whole chip, including system clocks and all peripheral clocks. The clock controller also implements the power control function with the individually clock ON/OFF control, clock source selection and a clock divider. The chip will not enter Power-down mode until CPU sets the power down enable bit (PWR_DOWN_EN) and Cortex-M0 core executes the WFI instruction. After that, chip enters Power-down mode and wait for wake-up interrupt source triggered to leave Power-down mode. In Power-down mode, the clock controller turns off the external 4~24 MHz high speed crystal and internal 22.1184 MHz high speed oscillator to reduce the overall system power consumption.

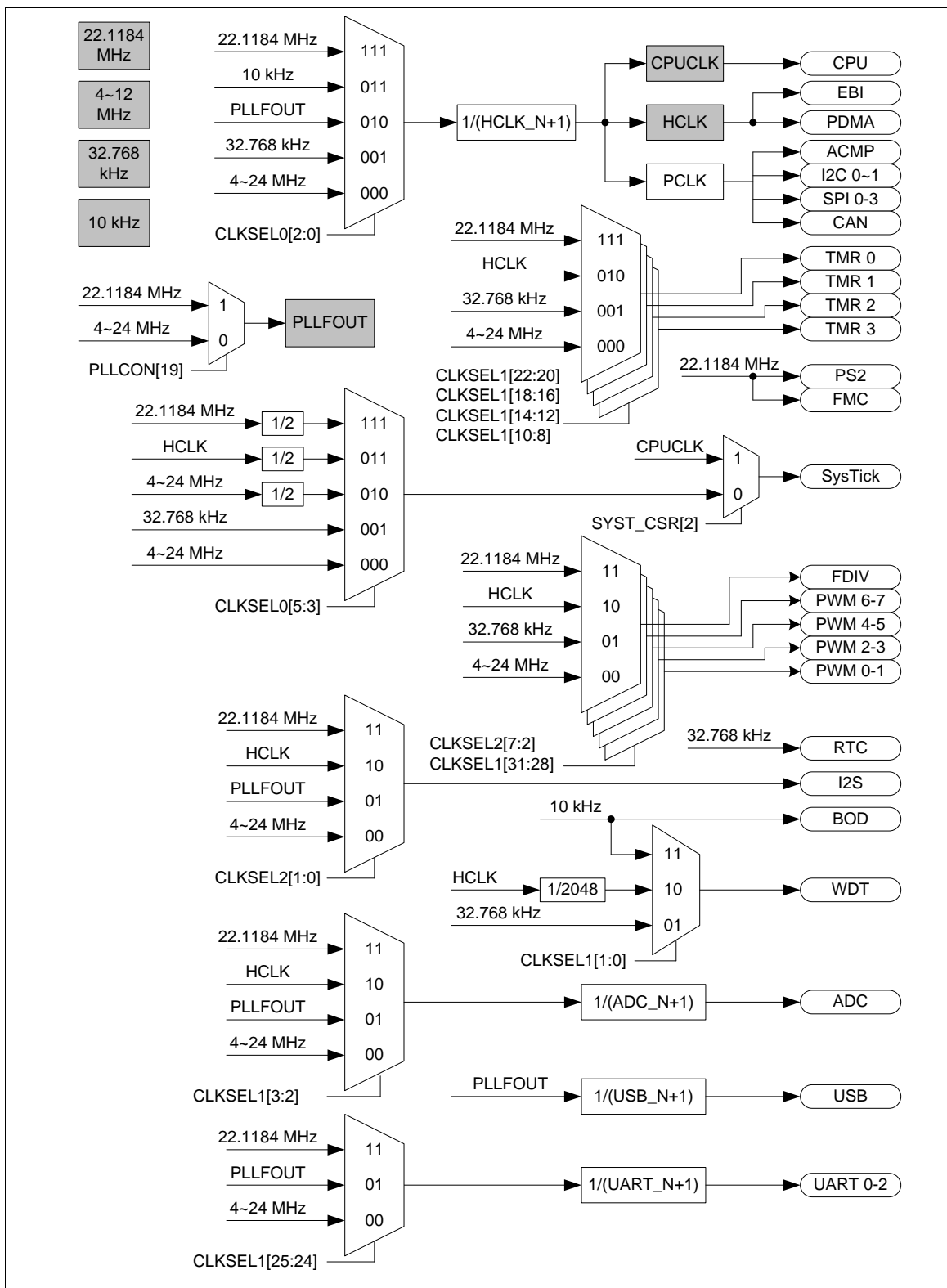

Figure 5-4 Clock Generator Global View Diagram

5.3.2 Clock Generator

The clock generator consists of 5 clock sources which are listed below:

- One external 32.768 kHz low speed crystal
- One external 4~24 MHz high speed crystal
- One programmable PLL FOUT(PLL source consists of external 4~24 MHz high speed crystal and internal 22.1184 MHz high speed oscillator)
- One internal 22.1184 MHz high speed oscillator
- One internal 10 kHz low speed oscillator

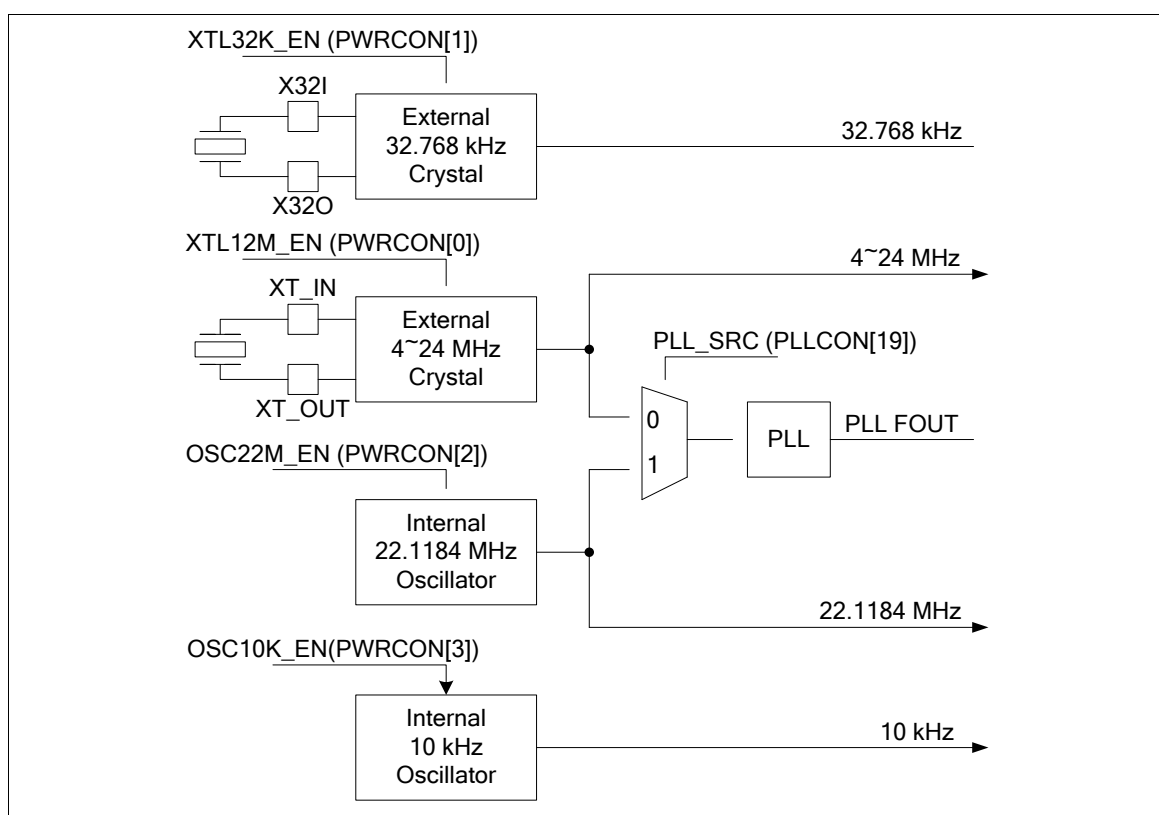

Figure 5-5 Clock Generator Block Diagram

5.3.3 System Clock and SysTick Clock

The system clock has 5 clock sources which were generated from clock generator block. The clock source switch depends on the register HCLK_S (CLKSEL0[2:0]). The block diagram is shown in Figure 5-6.

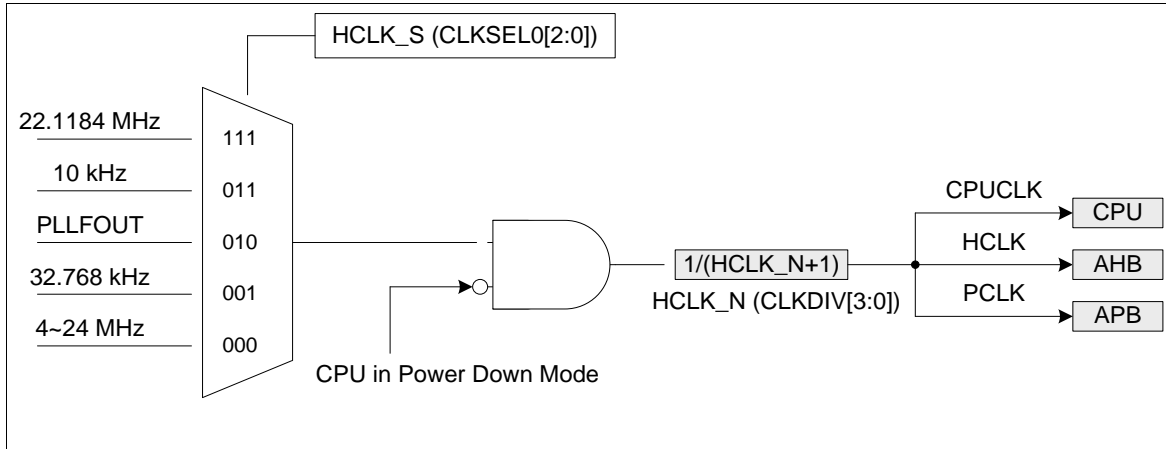

Figure 5-6 System Clock Block Diagram

The clock source of SysTick in Cortex-M0 core can use CPU clock or external clock (SYST_CSR[2]). If using external clock, the SysTick clock (STCLK) has 5 clock sources. The clock source switch depends on the setting of the register STCLK_S (CLKSEL0[5:3]). The block diagram is shown in Figure 5-7.

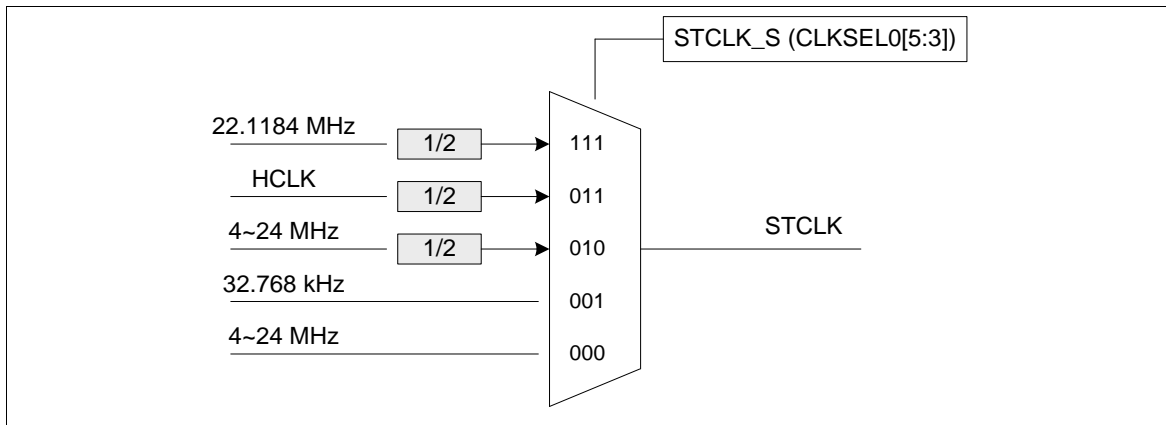

Figure 5-7 SysTick Clock Control Block Diagram



5.3.4 Peripherals Clock

The peripherals clock had different clock source switch setting which depends on the different peripheral. Please refer the CLKSEL1 and CLKSEL2 register description in 5.3.7.

5.3.5 Power-down Mode Clock

When chip enters into Power-down mode, system clocks, some clock sources, and some peripheral clocks will be disabled. Some clock sources and peripherals clock are still active in Power-down mode.

The clocks still active are listed below:

- Clock Generator
 - ◆ Internal 10 kHz low speed oscillator clock
 - ◆ External 32.768 kHz low speed crystal clock
- Peripherals Clock (When these IP adopt external 32.768 kHz low speed crystal or 10 kHz low speed oscillator as clock source)

5.3.6 Frequency Divider Output

This device is equipped a power-of-2 frequency divider which is composed by 16 chained divide-by-2 shift registers. One of the 16 shift register outputs selected by a sixteen to one multiplexer is reflected to CLKO function pin. Therefore there are 16 options of power-of-2 divided clocks with the frequency from $F_{in}/2^1$ to $F_{in}/2^{16}$ where F_{in} is input clock frequency to the clock divider.

The output formula is $F_{out} = F_{in}/2^{(N+1)}$, where F_{in} is the input clock frequency, F_{out} is the clock divider output frequency and N is the 4-bit value in FSEL (FRQDIV[3:0]).

When writing 1 to DIVIDER_EN (FRQDIV[4]), the chained counter starts to count. When writing 0 to DIVIDER_EN (FRQDIV[4]), the chained counter continuously runs till divided clock reaches low state and stay in low state.

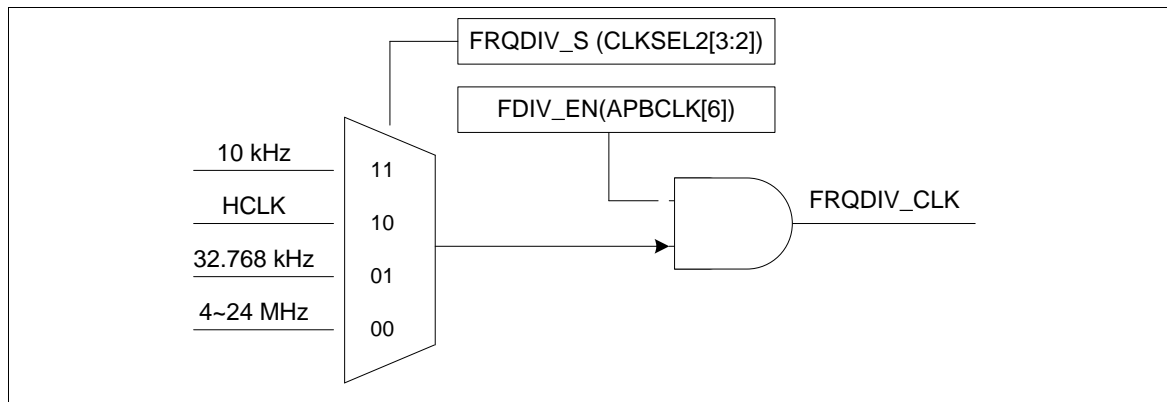

Figure 5-8 Clock Source of Frequency Divider

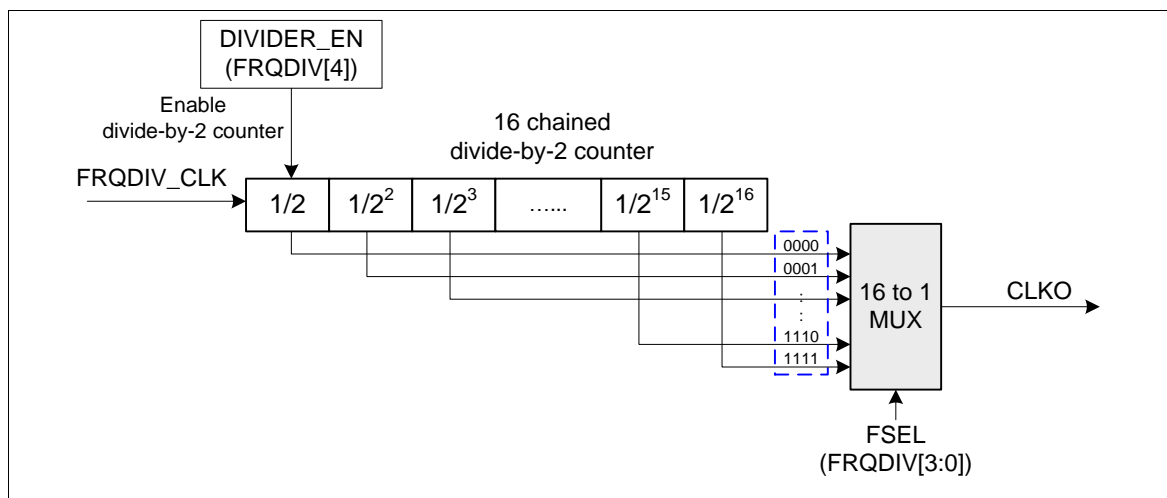

Figure 5-9 Block Diagram of Frequency Divider



5.3.7 Register Map

R: read only, W: write only, R/W: both read and write

Register	Offset	R/W	Description	Reset Value
CLK Base Address:				
CLK_BA = 0x5000_0200				
PWRCON	CLK_BA+0x00	R/W	System Power Down Control Register	0x0000_001X
AHBCLK	CLK_BA+0x04	R/W	AHB Devices Clock Enable Control Register	0x0000_000D
APBCLK	CLK_BA+0x08	R/W	APB Devices Clock Enable Control Register	0x0000_000X
CLKSTATUS	CLK_BA+0x0C	R/W	Clock status monitor Register	0x0000_00XX
CLKSEL0	CLK_BA+0x10	R/W	Clock Source Select Control Register 0	0x0000_003X
CLKSEL1	CLK_BA+0x14	R/W	Clock Source Select Control Register 1	0xFFFF_FFFF
CLKSEL2	CLK_BA+0x1C	R/W	Clock Source Select Control Register 2	0x0000_00FF
CLKDIV	CLK_BA+0x18	R/W	Clock Divider Number Register	0x0000_0000
PLLCON	CLK_BA+0x20	R/W	PLL Control Register	0x0005_C22E
FRQDIV	CLK_BA+0x24	R/W	Frequency Divider Control Register	0x0000_0000



5.3.8 Register Description

Power Down Control Register (PWRCON)

Except the BIT[6], all the other bits are protected, program these bits need to write “59h”, “16h”, “88h” to address 0x5000_0100 to disable register protection. Refer to the register REGWRPROT at address GCR_BA+0x100

Register	Offset	R/W	Description	Reset Value
PWRCON	CLK_BA+0x00	R/W	System Power Down Control Register	0x0000_001X

31	30	29	28	27	26	25	24
Reserved							
23	22	21	20	19	18	17	16
Reserved							
15	14	13	12	11	10	9	8
Reserved							PD_WAIT_CPU
7	6	5	4	3	2	1	0
PWR_DOWN_EN	PD_WU_STS	PD_WU_INT_EN	PD_WU_DLY	OSC10K_EN	OSC22M_EN	XTL32K_EN	XTL12M_EN

Bits	Description
[31:9]	Reserved Reserve
[8]	PD_WAIT_CPU This Bit Control the Power Down Entry Condition (Write-protection Bit) 1 = Chip enters Power-down mode when the both PD_WAIT_CPU and PWR_DOWN_EN bits are set to 1 and CPU run WFI instruction. 0 = Chip enters Power-down mode when the PWR_DOWN_EN bit is set to 1
[7]	PWR_DOWN_EN System Power Down Enable Bit (Write-protection Bit) When this bit is set to 1, the Power-down mode is enabled and chip power down behavior will depend on the PD_WAIT_CPU bit (a) If the PD_WAIT_CPU is 0, then the chip enters Power-down mode immediately after the PWR_DOWN_EN bit set. (b) if the PD_WAIT_CPU is 1, then the chip keeps active till the CPU sleep mode is also active and then the chip enters Power-down mode When chip wakes up from Power-down mode, this bit is auto cleared. Users need to set this bit again for next power down. In Power-down mode, external 4~24 MHz high speed crystal and the internal 22.1184 MHz high speed oscillator will be disabled in this mode, but the external 32.768 kHz low speed crystal and internal 10 kHz low speed oscillator are not controlled by Power-down mode. In Power-down mode, the PLL and system clock are disabled, and ignored the clock source selection. The clocks of peripheral are not controlled by Power-down mode, if the peripheral clock source is from external 32.768 kHz low speed crystal or the



		<p>internal 10 kHz low speed oscillator.</p> <p>1 = Chip enters the Power-down mode instant or wait CPU sleep command WFI</p> <p>0 = Chip operating normally or chip in idle mode because of WFI command</p>
[6]	PD_WU_STS	<p>Power-down Mode Wake-up Interrupt Status</p> <p>Set by “power down wake-up event”, it indicates that resume from Power-down mode”</p> <p>The flag is set if the GPIO, USB, UART, WDT, CAN, ACMP, BOD or RTC wake-up occurred</p> <p>Write 1 to clear the bit to 0.</p> <p>Note: This bit is working only if PD_WU_INT_EN (PWRCON[5]) set to 1.</p>
[5]	PD_WU_INT_EN	<p>Power-down Mode Wake-up Interrupt Enable (Write-protection Bit)</p> <p>0 = Disabled</p> <p>1 = Enabled</p> <p>The interrupt will occur when both PD_WU_STS and PD_WU_INT_EN are high.</p>
[4]	PD_WU_DLY	<p>Enable the Wake-up Delay Counter (Write-protection Bit)</p> <p>When the chip wakes up from Power-down mode, the clock control will delay certain clock cycles to wait system clock stable.</p> <p>The delayed clock cycle is 4096 clock cycles when chip work at external 4~24 MHz high speed crystal, and 256 clock cycles when chip work at internal 22.1184 MHz high speed oscillator.</p> <p>1 = Clock cycles delay Enabled</p> <p>0 = Clock cycles delay Disabled</p>
[3]	OSC10K_EN	<p>Internal 10 kHz Low Speed Oscillator Enable (Write-protection Bit)</p> <p>1 = Internal 10 kHz low speed oscillator Enabled</p> <p>0 = Internal 10 kHz low speed oscillator Disabled</p>
[2]	OSC22M_EN	<p>Internal 22.1184 MHz High Speed Oscillator Enable (Write-protection Bit)</p> <p>1 = Internal 22.1184 MHz high speed oscillator Enabled</p> <p>0 = Internal 22.1184 MHz high speed oscillator Disabled</p>
[1]	XTL32K_EN	<p>External 32.768 kHz Low Speed Crystal Enable (Write-protection Bit)</p> <p>1 = External 32.768 kHz low speed crystal Enabled (Normal operation)</p> <p>0 = External 32.768 kHz low speed crystal Disabled</p>
[0]	XTL12M_EN	<p>External 4~24 MHz High Speed Crystal Enable (Write-protection Bit)</p> <p>The default bit value is set by flash controller user configuration register config0 [26:24]. When the default clock source is from external 4~24 MHz high speed crystal, this bit is set to 1 automatically</p> <p>1 = External 4~24 MHz high speed crystal Enabled</p> <p>0 = External 4~24 MHz high speed crystal Disabled</p>



Register/Instruction Mode	PWR_DOWN_EN	PD_WAIT_CPU	CPU run WFI instruction	Clock Disable
Normal Operation	0	0	NO	All clocks are disabled by control register
Idle Mode (CPU Entry Sleep Mode)	0	x	YES	Only CPU clock is disabled
Power-down Mode	1	0	NO	Most clocks are disabled except 10 kHz/32.768 kHz, only RTC/WDT/Timer/PWM peripheral clock are still enabled.
Power-down Mode (CPU Entry Deep Sleep Mode)	1	1	YES	Most clocks are disabled except 10 kHz/32.768 kHz, only RTC/WDT/Timer/PWM peripheral clock are still enabled.

Table 5-5 Power-down Mode Control Table

When chip enters Power-down mode, user can wake up chip by some interrupt sources. User should enable related interrupt sources and NVIC IRQ enable bits (NVIC_ISER) before set PWR_DOWN_EN bit in PWRCON[7] to ensure chip can enter power down and be woken-up successfully.



AHB Devices Clock Enable Control Register (AHBCLK)

These bits for this register are used to enable/disable clock for system clock PDMA clock and EBI clock.

Register	Offset	R/W	Description	Reset Value
AHBCLK	CLK_BA+0x04	R/W	AHB Devices Clock Enable Control Register	0x0000_000D

31	30	29	28	27	26	25	24
Reserved							
23	22	21	20	19	18	17	16
Reserved							
15	14	13	12	11	10	9	8
Reserved							
7	6	5	4	3	2	1	0
Reserved				EBI_EN	ISP_EN	PDMA_EN	Reserved

Bits	Description	
[31:4]	Reserved	Reserved
[3]	EBI_EN	EBI Controller Clock Enable Control 1 = EBI engine clock Enabled. 0 = EBI engine clock Disabled.
[2]	ISP_EN	Flash ISP Controller Clock Enable Control 1 = Flash ISP engine clock Enabled 0 = Flash ISP engine clock Disabled
[1]	PDMA_EN	PDMA Controller Clock Enable Control 1 = PDMA engine clock Enabled. 0 = PDMA engine clock Disabled.
[0]	Reserved	Reserved



APB Devices Clock Enable Control Register (APBCLK)

These bits of this register are used to enable/disable clock for peripheral controller clocks.

Register	Offset	R/W	Description	Reset Value
APBCLK	CLK_BA+0x08	R/W	APB Devices Clock Enable Control Register	0x0000_000X

31	30	29	28	27	26	25	24
PS2_EN	ACMP_EN	I2S_EN	ADC_EN	USBD_EN	Reserved		CAN0_EN
23	22	21	20	19	18	17	16
PWM67_EN	PWM45_EN	PWM23_EN	PWM01_EN	Reserved	UART2_EN	UART1_EN	UART0_EN
15	14	13	12	11	10	9	8
SPI3_EN	SPI2_EN	SPI1_EN	SPI0_EN	Reserved		I2C1_EN	I2C0_EN
7	6	5	4	3	2	1	0
Reserved	FDIV_EN	TMR3_EN	TMR2_EN	TMR1_EN	TMR0_EN	RTC_EN	WDT_EN

Bits	Description	
[31]	PS2_EN	PS/2 Clock Enable 1 = PS/2 clock Enabled. 0 = PS/2 clock Disabled.
[30]	ACMP_EN	Analog Comparator Clock Enable 1 = Analog Comparator Clock Enabled. 0 = Analog Comparator Clock Disabled.
[29]	I2S_EN	I²S Clock Enable 1 = I ² S Clock Enabled. 0 = I ² S Clock Disabled.
[28]	ADC_EN	Analog-Digital-Converter (ADC) Clock Enable 1 = ADC clock Enabled. 0 = ADC clock Disabled.
[27]	USBD_EN	USB 2.0 FS Device Controller Clock Enable 1 = USB clock Enabled. 0 = USB clock Disabled.
[26:25]	Reserved	Reserved
[24]	CAN0_EN	CAN Bus Controller-0 Clock Enable 1 = CAN0 clock Enabled. 0 = CAN0 clock Disabled.
[23]	PWM67_EN	PWM_67 Clock Enable 1 = PWM67 clock Enabled.



		0 = PWM67 clock Disabled.
[22]	PWM45_EN	PWM_45 Clock Enable 1 = PWM45 clock Enabled. 0 = PWM45 clock Disabled.
[21]	PWM23_EN	PWM_23 Clock Enable 1 = PWM23 clock Enabled. 0 = PWM23 clock Disabled.
[20]	PWM01_EN	PWM_01 Clock Enable 1 = PWM01 clock Enabled. 0 = PWM01 clock Disabled.
[19]	Reserved	Reserved
[18]	UART2_EN	UART2 Clock Enable 1 = UART2 clock Enabled. 0 = UART2 clock Disabled.
[17]	UART1_EN	UART1 Clock Enable 1 = UART1 clock Enabled. 0 = UART1 clock Disabled.
[16]	UART0_EN	UART0 Clock Enable 1 = UART0 clock Enabled. 0 = UART0 clock Disabled.
[15]	SPI3_EN	SPI3 Clock Enable 1 = SPI3 clock Enabled. 0 = SPI3 clock Disabled.
[14]	SPI2_EN	SPI2 Clock Enable 1 = SPI2 clock Enabled. 0 = SPI2 clock Disabled.
[13]	SPI1_EN	SPI1 Clock Enable 1 = SPI1 clock Enabled 0 = SPI1 clock Disabled
[12]	SPI0_EN	SPI0 Clock Enable 1 = SPI0 clock Enabled. 0 = SPI0 clock Disabled.
[11:10]	Reserved	Reserved
[9]	I2C1_EN	I²C1 Clock Enable 1 = I ² C1 clock Enabled. 0 = I ² C1 clock Disabled.
[8]	I2C0_EN	I²C0 Clock Enable 1 = I ² C0 clock Enabled. 0 = I ² C0 clock Disabled.



[7]	Reserved	Reserved
[6]	FDIV_EN	Frequency Divider Output Clock Enable 1 = FDIV clock Enabled. 0 = FDIV clock Disabled.
[5]	TMR3_EN	Timer3 Clock Enable 1 = Timer3 clock Enabled 0 = Timer3 clock Disabled
[4]	TMR2_EN	Timer2 Clock Enable 1 = Timer2 clock Enabled 0 = Timer2 clock Disabled
[3]	TMR1_EN	Timer1 Clock Enable 1 = Timer1 clock Enabled 0 = Timer1 clock Disabled
[2]	TMR0_EN	Timer0 Clock Enable 1 = Timer0 clock Enabled 0 = Timer0 clock Disabled
[1]	RTC_EN	Real-Time-Clock APB interface Clock Enable This bit is used to control the RTC APB clock only, The RTC engine clock source is from the external 32.768 kHz low speed crystal. 1 = RTC clock Enabled 0 = RTC clock Disabled
[0]	WDT_EN	Watchdog Timer Clock Enable (Write-protection Bit) This bit is the protected bit. It means programming this needs to write "59h", "16h", "88h" to address 0x5000_0100 to disable register protection. Refer to the register REGWRPROT at address GCR_BA+0x100. 1 = Watchdog Timer Clock Enabled 0 = Watchdog Timer Clock Disabled



Clock status Register (CLKSTATUS)

These bits of this register are used to monitor if the chip clock source stable or not, and whether clock switch failed.

Register	Offset	R/W	Description	Reset Value
CLKSTATUS	CLK_BA+0x0C	R/W	Clock status monitor Register	0x0000_00XX

31	30	29	28	27	26	25	24
Reserved							
23	22	21	20	19	18	17	16
Reserved							
15	14	13	12	11	10	9	8
Reserved							
7	6	5	4	3	2	1	0
CLK_SW_FAIL	Reserved		OSC22M_STB	OSC10K_STB	PLL_STB	XTL32K_STB	XTL12M_STB

Bits	Description
[31:8]	Reserved
[7]	<p>CLK_SW_FAIL</p> <p>Clock Switching Fail Flag 1 = Clock switching failure 0 = Clock switching success</p> <p>This bit is updated when software switches system clock source. If switch target clock is stable, this bit will be set to 0. If switch target clock is not stable, this bit will be set to 1.</p> <p>Write 1 to clear the bit to 0.</p>
[6:5]	Reserved
[4]	<p>OSC22M_STB</p> <p>Internal 22.1184 MHz High Speed Oscillator Clock Source Stable Flag 1 = Internal 22.1184 MHz high speed oscillator clock is stable 0 = Internal 22.1184 MHz high speed oscillator clock is not stable or disabled</p> <p>This is read only bit</p>
[3]	<p>OSC10K_STB</p> <p>Internal 10 kHz Low Speed Oscillator Clock Source Stable Flag 1 = Internal 10 kHz low speed oscillator clock is stable 0 = Internal 10 kHz low speed oscillator clock is not stable or disabled</p> <p>This is read only bit</p>
[2]	<p>PLL_STB</p> <p>Internal PLL Clock Source Stable Flag 1 = Internal PLL clock is stable 0 = Internal PLL clock is not stable or disabled</p> <p>This bit is read only.</p>



[1]	XTL32K_STB	External 32.768 kHz Low Speed Crystal Clock Source Stable Flag 1 = External 32.768 kHz low speed crystal clock is stable 0 = External 32.768 kHz low speed crystal clock is not stable or disabled This bit is read only.
[0]	XTL12M_STB	External 4~24 MHz High Speed Crystal Clock Source Stable Flag 1 = External 4~24 MHz high speed crystal clock is stable 0 = External 4~24 MHz high speed crystal clock is not stable or disabled This bit is read only.



Clock Source Select Control Register 0 (CLKSEL0)

Register	Offset	R/W	Description	Reset Value
CLKSEL0	CLK_BA+0x10	R/W	Clock Source Select Control Register 0	0x0000_003X

31	30	29	28	27	26	25	24
Reserved							
23	22	21	20	19	18	17	16
Reserved							
15	14	13	12	11	10	9	8
Reserved							
7	6	5	4	3	2	1	0
Reserved		STCLK_S			HCLK_S		

Bits	Description
[31:6]	Reserved
[5:3]	<p>STCLK_S</p> <p>Cortex_M0 SysTick Clock Source Selection (Write-protection Bits) If SYST_CSR[2]=0, SysTick uses listed clock source below These bits are protected bit. It means programming this bit needs to write "59h", "16h", "88h" to address 0x5000_0100 to disable register protection. Refer to the register REGWRPROT at address GCR_BA+0x100.</p> <p>000 = Clock source from external 4~24 MHz high speed crystal clock 001 = Clock source from external 32.768 kHz low speed crystal clock 010 = Clock source from external 4~24 MHz high speed crystal clock/2 011 = Clock source from HCLK/2 111 = Clock source from internal 22.1184 MHz high speed oscillator clock/2</p>
[2:0]	<p>HCLK_S</p> <p>HCLK Clock Source Selection (Write-protection Bits)</p> <ol style="list-style-type: none"> Before clock switching, the related clock sources (both pre-select and new-select) must be turn on The 3-bit default value is reloaded from the value of CFOSC (Config0[26:24]) in user configuration register of Flash controller by any reset. Therefore the default value is either 000b or 111b. These bits are protected bit. It means programming this bit needs to write "59h", "16h", "88h" to address 0x5000_0100 to disable register protection. Refer to the register REGWRPROT at address GCR_BA+0x100. <p>000 = Clock source from external 4~24 MHz high speed crystal clock 001 = Clock source from external 32.768 kHz low speed crystal clock 010 = Clock source from PLL clock 011 = Clock source from internal 10 kHz low speed oscillator clock 111 = Clock source from internal 22.1184 MHz high speed oscillator clock</p>



Clock Source Select Control Register 1 (CLKSEL1)

Before clock switching, the related clock sources (pre-select and new-select) must be turned on.

Register	Offset	R/W	Description	Reset Value
CLKSEL1	CLK_BA+0x14	R/W	Clock Source Select Control Register 1	0xFFFF_FFFF

31	30	29	28	27	26	25	24
PWM23_S		PWM01_S		Reserved		UART_S	
23	22	21	20	19	18	17	16
Reserved	TMR3_S			Reserved	TMR2_S		
15	14	13	12	11	10	9	8
Reserved	TMR1_S			Reserved	TMR0_S		
7	6	5	4	3	2	1	0
Reserved				ADC_S		WDT_S	

Bits	Description
[31:30]	<p>PWM23_S</p> <p>PWM2 and PWM3 clock source select PWM2 and PWM3 uses the same Engine clock source, both of them use the same prescaler</p> <p>00 = Clock source from external 4~24 MHz high speed crystal clock 01 = Clock source from external 32.768 kHz low speed crystal clock 10 = Clock source from HCLK 11 = Clock source from internal 22.1184 MHz high speed oscillator clock</p>
[29:28]	<p>PWM01_S</p> <p>PWM0 and PWM1 clock source select PWM0 and PWM1 uses the same Engine clock source, both of them use the same prescaler</p> <p>00 = Clock source from external 4~24 MHz high speed crystal clock 01 = Clock source from external 32.768 kHz low speed crystal clock 10 = Clock source from HCLK 11 = Clock source from internal 22.1184 MHz high speed oscillator clock</p>
[27:26]	Reserved Reserved
[25:24]	<p>UART_S</p> <p>UART clock source select 00 = Clock source from external 4~24 MHz high speed crystal clock 01 = Clock source from PLL clock 11 = Clock source from internal 22.1184 MHz high speed oscillator clock</p>
[23]	Reserved Reserved
[22:20]	<p>TMR3_S</p> <p>TIMER3 clock source select 000 = Clock source from external 4~24 MHz high speed crystal clock</p>



		001 = Clock source from external 32.768 kHz low speed crystal clock 010 = Clock source from HCLK 111 = Clock source from internal 22.1184 MHz high speed oscillator clock
[19]	Reserved	Reserved
[18:16]	TMR2_S	TIMER2 clock source select 000 = Clock source from external 4~24 MHz high speed crystal clock 001 = Clock source from external 32.768 kHz low speed crystal clock 010 = Clock source from HCLK 111 = Clock source from internal 22.1184 MHz high speed oscillator clock
[15]	Reserved	Reserved
[14:12]	TMR1_S	TIMER1 clock source select 000 = Clock source from external 4~24 MHz high speed crystal clock 001 = Clock source from external 32.768 kHz low speed crystal clock 010 = Clock source from HCLK 111 = Clock source from internal 22.1184 MHz high speed oscillator clock
[11]	Reserved	Reserved
[10:8]	TMR0_S	TIMER0 clock source select 000 = Clock source from external 4~24 MHz high speed crystal clock 001 = Clock source from external 32.768 kHz low speed crystal clock 010 = Clock source from HCLK 111 = Clock source from internal 22.1184 MHz high speed oscillator clock
[7:4]	Reserved	Reserved
[3:2]	ADC_S	ADC clock source select 00 = Clock source from external 4~24 MHz high speed crystal clock 01 = Clock source from PLL clock 10 = Clock source from HCLK 11 = Clock source from internal 22.1184 MHz high speed oscillator clock
[1:0]	WDT_S	Watchdog Timer Clock Source Selection (Write-protection Bits) These bits are protected bit, program this need to write "59h", "16h", "88h" to address 0x5000_0100 to disable register protection. Refer to the register REGWRPROT at address GCR_BA+0x100. 01 = Clock source from external 32.768 kHz low speed crystal clock 10 = Clock source from HCLK/2048 clock 11 = Clock source from internal 10 kHz low speed oscillator clock



Clock Source Select Control Register 2 (CLKSEL2)

Before clock switching, the related clock sources (pre-select and new-select) must be turned on.

Register	Offset	R/W	Description	Reset Value
CLKSEL2	CLK_BA+0x1C	R/W	Clock Source Select Control Register 2	0x0000_00FF

31	30	29	28	27	26	25	24
Reserved							
23	22	21	20	19	18	17	16
Reserved							
15	14	13	12	11	10	9	8
Reserved							
7	6	5	4	3	2	1	0
PWM67_S		PWM45_S		FRQDIV_S		I2S_S	

Bits	Description
[31:8]	Reserved Reserved
[7:6]	PWM67_S PWM6 and PWM7 Clock Source Select PWM6 and PWM7 used the same Engine clock source, both of them use the same prescaler 00 = Clock source from external 4~24 MHz high speed crystal clock 01 = Clock source from external 32.768 kHz low speed crystal clock 10 = Clock source from HCLK 11 = Clock source from internal 22.1184 MHz high speed oscillator clock
[5:4]	PWM45_S PWM4 and PWM5 Clock Source Select PWM4 and PWM5 used the same Engine clock source, both of them use the same prescaler 00 = Clock source from external 4~24 MHz high speed crystal clock 01 = Clock source from external 32.768 kHz low speed crystal clock 10 = Clock source from HCLK 11 = Clock source from internal 22.1184 MHz high speed oscillator clock
[3:2]	FRQDIV_S Clock Divider Clock Source Select 00 = Clock source from external 4~24 MHz high speed crystal clock 01 = Clock source from external 32.768 kHz low speed crystal clock 10 = Clock source from HCLK 11 = Clock source from internal 22.1184 MHz high speed oscillator clock
[1:0]	I2S_S I²S Clock Source Select 00 = Clock source from external 4~24 MHz high speed crystal clock 01 = Clock source from PLL clock



		10 = Clock source from HCLK 11 = Clock source from internal 22.1184 MHz high speed oscillator clock
--	--	--



Clock Divider Register (CLKDIV)

Register	Offset	R/W	Description	Reset Value
CLKDIV	CLK_BA+0x18	R/W	Clock Divider Number Register	0x0000_0000

31	30	29	28	27	26	25	24
Reserved							
23	22	21	20	19	18	17	16
ADC_N							
15	14	13	12	11	10	9	8
Reserved				UART_N			
7	6	5	4	3	2	1	0
USB_N				HCLK_N			

Bits	Description	
[31:24]	Reserved	Reserved
[23:16]	ADC_N	ADC clock divide number from ADC clock source The ADC clock frequency = (ADC clock source frequency) / (ADC_N + 1)
[15:12]	Reserved	Reserved
[11:8]	UART_N	UART clock divide number from UART clock source The UART clock frequency = (UART clock source frequency) / (UART_N + 1)
[7:4]	USB_N	USB clock divide number from PLL clock The USB clock frequency = (PLL frequency) / (USB_N + 1)
[3:0]	HCLK_N	HCLK clock divide number from HCLK clock source The HCLK clock frequency = (HCLK clock source frequency) / (HCLK_N + 1)



PLL Control Register (PLLCON)

The PLL reference clock input is from the external 4~24 MHz high speed crystal clock input or from the internal 22.1184 MHz high speed oscillator. These registers are use to control the PLL output frequency and PLL operating mode

Register	Offset	R/W	Description	Reset Value
PLLCON	CLK_BA+0x20	R/W	PLL Control Register	0x0005_C22E

31	30	29	28	27	26	25	24
Reserved							
23	22	21	20	19	18	17	16
Reserved				PLL_SRC	OE	BP	PD
15	14	13	12	11	10	9	8
OUT_DV		IN_DV					FB_DV
7	6	5	4	3	2	1	0
FB_DV							

Bits	Description	
[31:20]	Reserved	Reserved
[19]	PLL_SRC	PLL Source Clock Select 1 = PLL source clock from internal 22.1184 MHz high speed oscillator 0 = PLL source clock from external 4~24 MHz high speed crystal
[18]	OE	PLL OE (FOUT enable) pin Control 0 = PLL FOUT enable 1 = PLL FOUT is fixed low
[17]	BP	PLL Bypass Control 0 = PLL is in normal mode (Default) 1 = PLL clock output is same as clock input (XTALin)
[16]	PD	Power-down Mode If set the PWR_DOWN_EN bit to 1 in PWRCON register, the PLL will enter Power-down mode too. 0 = PLL is in normal mode 1 = PLL is in Power-down mode (Default)
[15:14]	OUT_DV	PLL Output Divider Control Pins Refer to the formulas below the table.
[13:9]	IN_DV	PLL Input Divider Control Pins Refer to the formulas below the table.
[8:0]	FB_DV	PLL Feedback Divider Control Pins



		Refer to the formulas below the table.
--	--	--

Output Clock Frequency Setting

$$F_{OUT} = F_{IN} \times \frac{NF}{NR} \times \frac{1}{NO}$$

Constraint:

1. $3.2MHz < F_{IN} < 150MHz$

2. $800KHz < \frac{F_{IN}}{2 * NR} < 8MHz$

$100MHz < F_{CO} = F_{IN} \times \frac{NF}{NR} < 200MHz$

3. $120MHz < F_{CO}$ is preferred

Symbol	Description
<i>F_{OUT}</i>	Output Clock Frequency
<i>F_{IN}</i>	Input (Reference) Clock Frequency
<i>NR</i>	Input Divider (IN_DV + 2)
<i>NF</i>	Feedback Divider (FB_DV + 2)
<i>NO</i>	OUT_DV = "00" : NO = 1 OUT_DV = "01" : NO = 2 OUT_DV = "10" : NO = 2 OUT_DV = "11" : NO = 4

Default Frequency Setting

The default value : 0xC22E

F_{IN} = 12 MHz

NR = (1+2) = 3

NF = (46+2) = 48

NO = 4

F_{OUT} = 12/4 x 48 x 1/3 = 48 MHz



Frequency Divider Control Register (FRQDIV)

Register	Offset	R/W	Description	Reset Value
FRQDIV	CLK_BA+0x24	R/W	Frequency Divider Control Register	0x0000_0000

31	30	29	28	27	26	25	24
Reserved							
23	22	21	20	19	18	17	16
Reserved							
15	14	13	12	11	10	9	8
Reserved							
7	6	5	4	3	2	1	0
Reserved			DIVIDER_EN	FSEL			

Bits	Description	
[31:5]	Reserved	Reserved
[4]	DIVIDER_EN	Frequency Divider Enable Bit 0 = Frequency Divider Disabled. 1 = Frequency Divider Enabled.
[3:0]	FSEL	Divider Output Frequency Selection Bits The formula of output frequency is $F_{out} = F_{in}/2^{(N+1)}$ F _{in} is the input clock frequency. F _{out} is the frequency of divider output clock. N is the 4-bit value of FSEL[3:0].

5.4 USB Device Controller (USB)

5.4.1 Overview

There is one set of USB 2.0 full-speed device controller and transceiver in this device, which is compliant with the USB 2.0 full-speed device specification and supports control/bulk/interrupt/isochronous transfer types.

In this device controller, there are two main interfaces: APB bus and USB bus that come from the USB PHY transceiver. For the APB bus, the CPU can program control registers through it. There are 512 bytes internal SRAM as data buffer in this controller. For IN or OUT transfer, it is necessary to write data to SRAM or read data from SRAM through the APB interface or SIE. Users need to set the effective starting address of SRAM for each endpoint buffer through “buffer segmentation register (USB_BUFSEGx)”.

There are 6 endpoints in this controller. Each of the endpoint can be configured as IN or OUT endpoint. All the operations including Control, Bulk, Interrupt and Isochronous transfer are implemented in this block. The block of ENDPOINT CONTROL is also used to manage the data sequential synchronization, endpoint states, current start address, transaction status, and data buffer status for each endpoint.

There are four different interrupt events in this controller, including wake-up function, device plug-in or plug-out event, USB events, such as IN ACK, OUT ACK etc, and BUS events, such as suspend and resume, etc. Any event will cause an interrupt, and users just need to check the related event flags in interrupt event status register (USB_INTSTS) to acknowledge what kind of interrupt occurring, and then check the related USB Endpoint Status Register (USB_EPSTS) to acknowledge what kind of event occurring in this endpoint.

A software-disable function is also supported for this USB controller. It is used to simulate the disconnection of this device from the host. If user enables DRVSE0 bit (USB_DRVSE0), the USB controller will force the output of USB_DP and USB_DM to level low and its function is disabled. After the DRVSE0 bit is disabled, host will enumerate the USB device again.

Also refer to *Universal Serial Bus Specification Revision 1.1*.

5.4.2 Features

This Universal Serial Bus (USB) performs a serial interface with a single connector type for attaching all USB peripherals to the host system. Following is the feature listing of this USB.

- Compliant with USB 2.0 Full-Speed specification
- Provides 1 interrupt vector with 4 different interrupt events (WAKEUP, FLDET, USB and BUS)
- Supports Control/Bulk/Interrupt/Isochronous transfer type
- Supports suspend function when no bus activity existing for 3 ms
- Provides 6 endpoints for configurable Control/Bulk/Interrupt/Isochronous transfer types and maximum 512 bytes buffer size
- Provides remote wake-up capability



5.4.3 Block Diagram

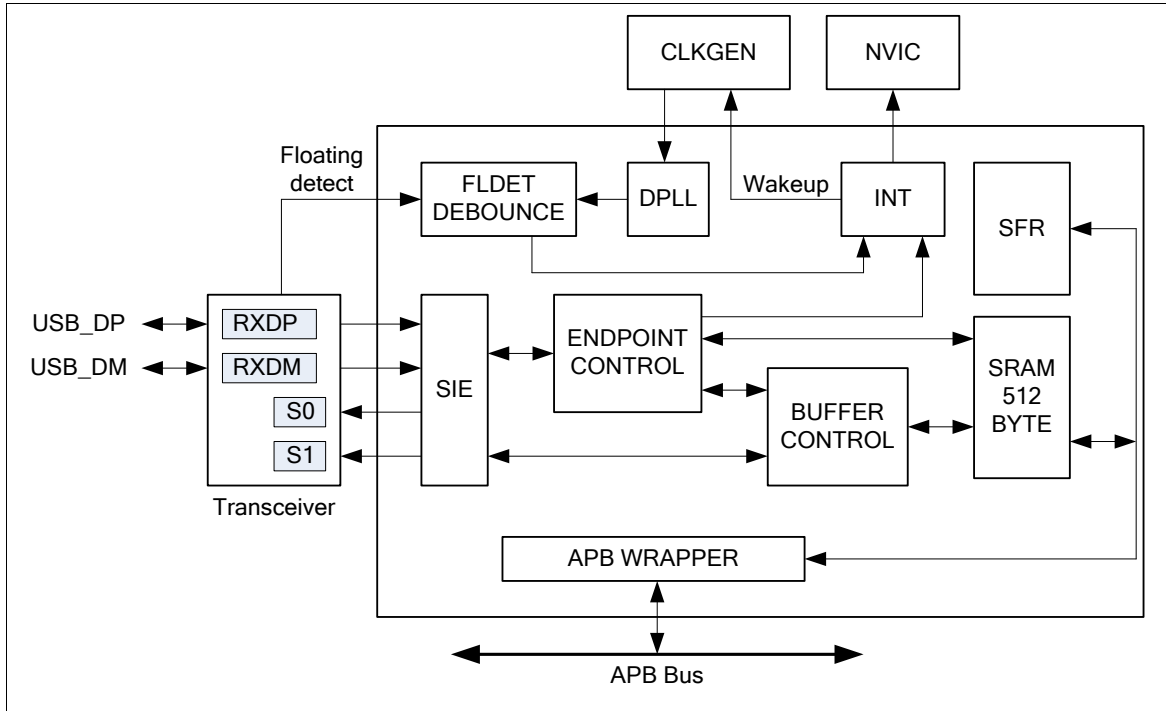

Figure 5-10 USB Block Diagram

5.4.4 Functional Description

5.4.4.1 SIE (Serial Interface Engine)

The Serial Interface Engine (SIE) is the front-end of the device controller and handles most of the USB packet protocol. The SIE typically comprehends signaling up to the transaction level. The functions that the SIE handles include:

- Packet recognition, transaction sequencing
- SOP, EOP, RESET, RESUME signal detection/generation
- Clock/Data separation
- NRZI Data encoding/decoding and bit-stuffing
- CRC generation and checking (for Token and Data)
- Packet ID (PID) generation and checking/ decoding
- Serial-Parallel/ Parallel-Serial conversion

5.4.4.2 Endpoint Control

There are 6 endpoints in the controller. Each of the endpoints can be configured as Control, Bulk, Interrupt, or Isochronous transfer type. All the operations including Control, Bulk, Interrupt and Isochronous transfer are implemented in this block. It is also used to manage the data sequential synchronization, endpoint state control, current endpoint start address, current transaction status, and data buffer status in each endpoint.

5.4.4.3 Digital Phase Lock Loop

The bit rate of USB data is 12 MHz. The DPLL use the 48 MHz which comes from the clock controller to lock the input data RXDP and RXDM. The 12 MHz bit rate clock is also converted from DPLL.

5.4.4.4 Floating De-bounce

A USB device may be plug-in or plug-out from the USB host. In order to monitor the state of a USB device when it is detached from the USB host, the device controller provides hardware de-bounce for USB floating detect interrupt to avoid bounce problems on USB plug-in or unplug. Floating detect interrupt appears about 10 ms later than USB plug-in or plug-out. A user can acknowledge USB plug-in/plug-out by reading register "USB_FLDET". The flag in "FLDET" represents the current state on the bus without de-bounce. If the FLDET is 1, it means the controller has plug-in the USB. If the user polling this flag to check USB state, he/she must add software de-bounce if necessary.

5.4.4.5 Interrupt

This USB provides 1 interrupt vector with 4 interrupt events (WAKEUP, FLDET, USB and BUS). The WAKEUP event is used to wake-up the system clock when Power-down mode is enabled. (The power mode function is defined in system power down control register, PWRCON). The FLDET event is used for USB plug-in or unplug. The USB event notifies users of some USB requests, such as IN ACK, OUT ACK etc., and the BUS event notifies users of some bus events, like suspend, resume, etc. User must set related bits in the interrupt enable register (USB_INTEN) of USB Device Controller to enable USB interrupts.

Wake-up interrupt is only present when the chip enters Power-down mode and then wake-up event had happened. After the chip enters Power-down mode, any change on USB_DP and USB_DM can wake-up this chip (provided that USB wake-up function is enabled). If this change is not intentionally, no interrupt but wake-up interrupt will occur. After USB wake-up, this interrupt will occur when no other USB interrupt events are present for more than 20ms. The following figure is the control flow of wake-up interrupt.

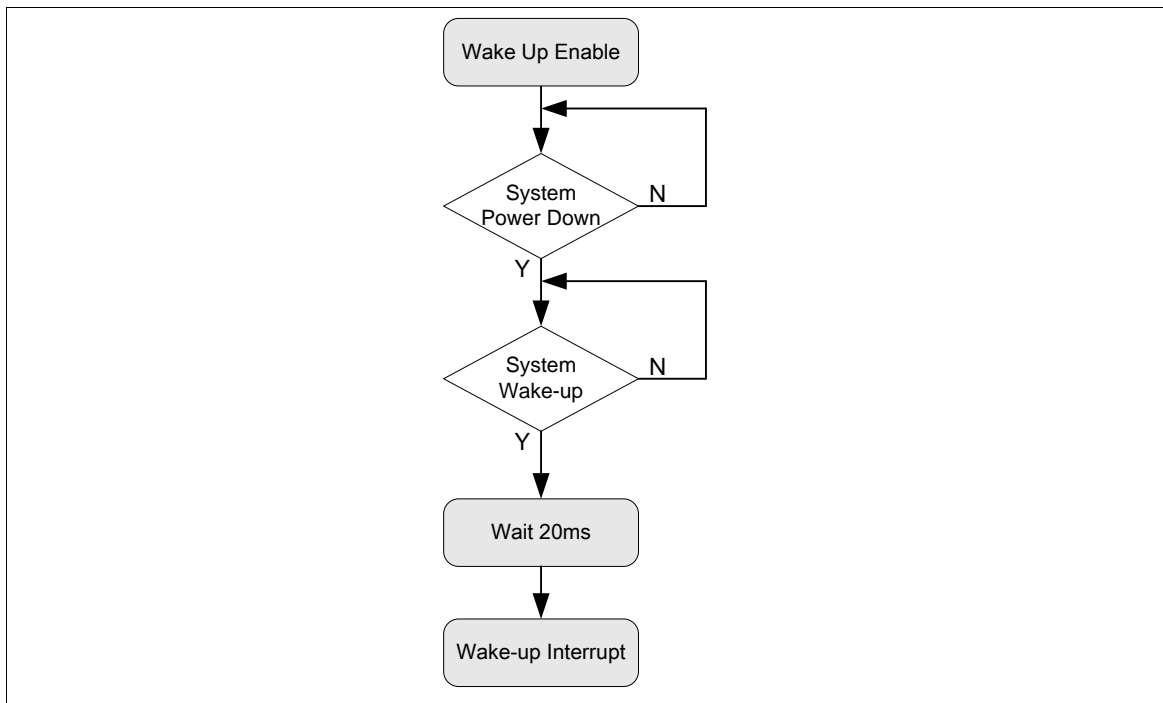

Figure 5-11 Wake-up Interrupt Operation Flow

USB interrupt is used to notify users of any USB event on the bus, and a user can read EPSTS (USB_EPSTS[25:8]) and EPEVT5~0 (USB_INTSTS[21:16]) to know what kind of request is to which endpoint and take necessary responses.

Same as USB interrupt, BUS interrupt notifies users of some bus events, like USB reset, suspend, time-out, and resume. A user can read USB_ATTR to acknowledge bus events.

5.4.4.6 Power Saving

USB turns off PHY transceiver automatically to save power while this chip enters Power-down mode. Furthermore, a user can write 0 into USB_ATTR[4] to turn off PHY under special circumstances like suspend to save power.



5.4.4.7 Buffer Control

There is 512 bytes SRAM in the controller and the 6 endpoints share this buffer. The user shall configure each endpoint's effective starting address in the buffer segmentation register before the USB function active. The BUFFER CONTROL block is used to control each endpoint's effective starting address and its SRAM size is defined in the MXPLD register.

Figure 5-12 depicts the starting address for each endpoint according the content of USB_BUFSEGx and USB_MXPLDx registers. If the USB_BUFSEG0 is programmed as 0x08h and USB_MXPLD0 is set as 0x40h, the SRAM size of endpoint 0 is start from USB_BA+0x108h and end in USB_BA+0x148h. (**Note:** the USB SRAM base is USB_BA+0x100h).

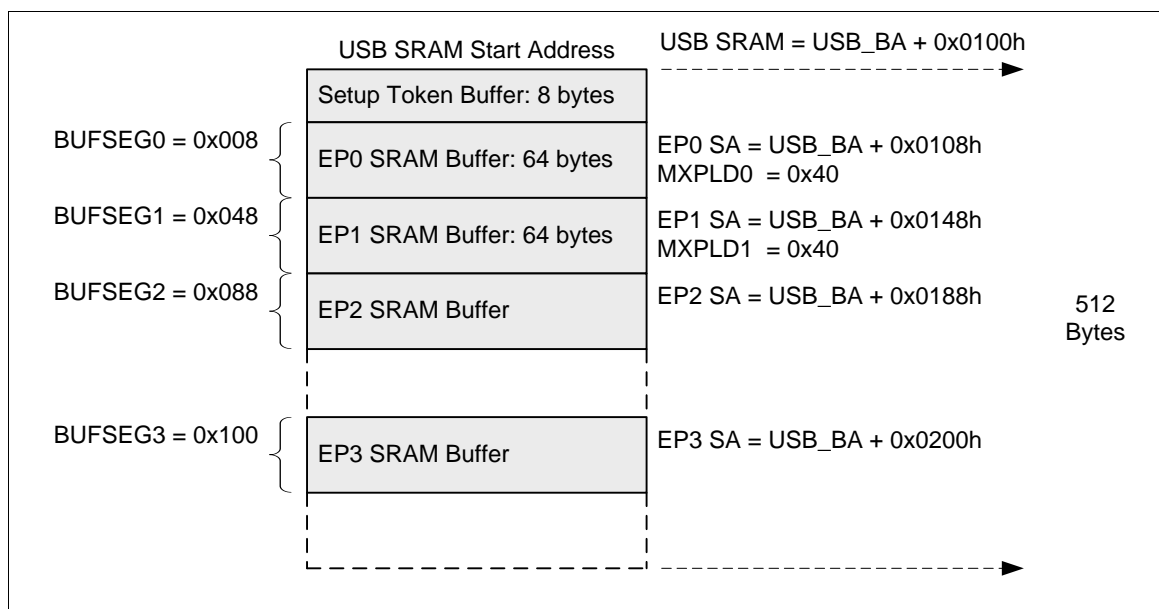

Figure 5-12 Endpoint SRAM Structure



5.4.4.8 Handling Transactions with USB Device Peripheral

User can use interrupt or polling USB_INTSTS to monitor the USB Transactions, when transactions occur, USB_INTSTS will be set by hardware and send an interrupt request to CPU (if related interrupt enabled), or user can polling USB_INTSTS to get these events without interrupt. The following is the control flow with interrupt enable.

When USB host has requested data from device controller, users need to prepare related data into the specified endpoint buffer in advance. After buffering the required data, users need to write the actual data length in the specified MAXPLD register. Once this register is written, the internal signal "In_Rdy" will be asserted and the buffering data will be transmitted immediately after receiving associated IN token from Host. Note that after transferring the specified data, the signal "In_Rdy" will de-assert automatically by hardware.

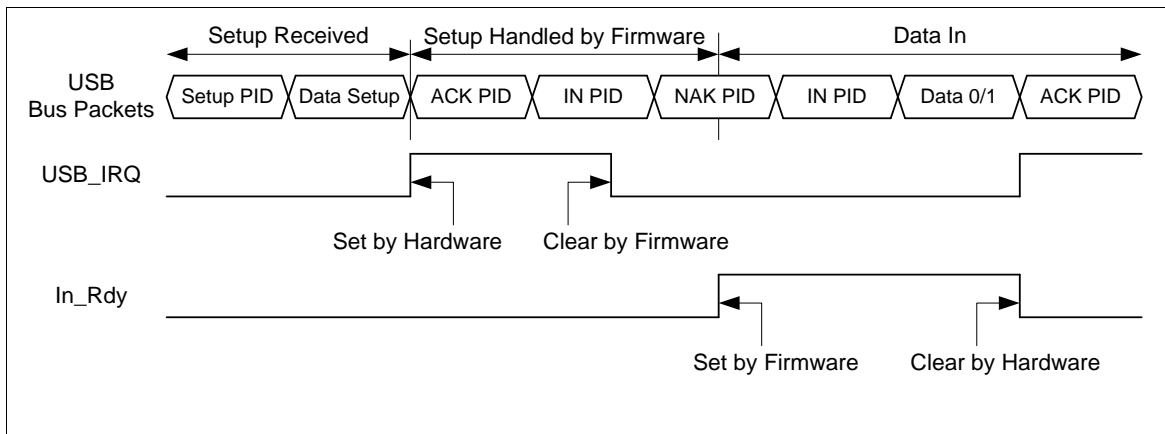

Figure 5-13 Setup Transaction followed by Data in Transaction

Alternatively, when USB host wants to transmit data to the OUT endpoint in the device controller, hardware will buffer these data to the specified endpoint buffer. After this transaction is completed, hardware will record the data length in related MAXPLD register and de-assert the signal "Out_Rdy". This will avoid hardware accepting next transaction until users move out current data in the related endpoint buffer. Once users have processed this transaction, the related register "MAXPLD" needs to be written by firmware to assert the signal "Out_Rdy" again to accept next transaction.

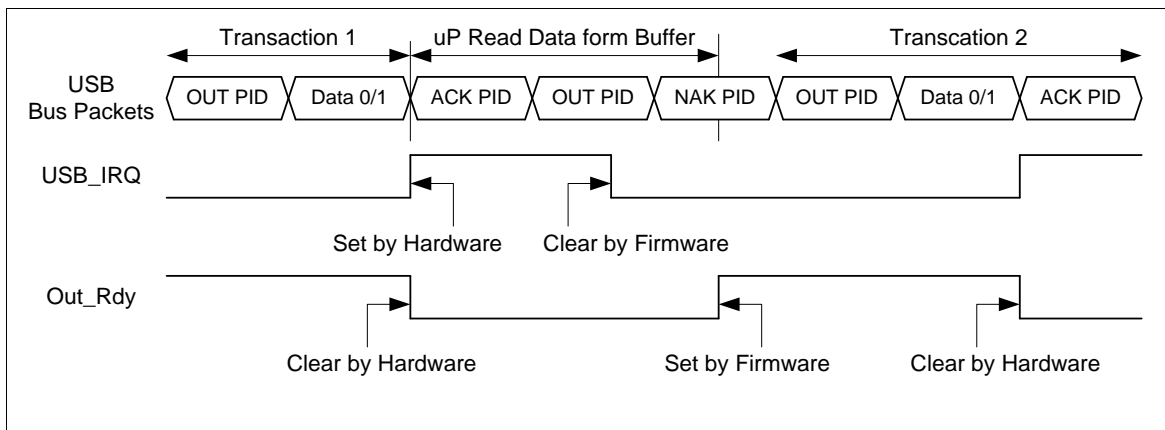



Figure 5-14 Data Out Transfer

5.4.5 Register and Memory Map

R: read only, W: write only, R/W: both read and write

Register	Offset	R/W	Description	Reset Value
USB Base Address:				
USB_BA = 0x4006_0000				
USB_INTEN	USB_BA+0x000	R/W	USB Interrupt Enable Register	0x0000_0000
USB_INTSTS	USB_BA+0x004	R/W	USB Interrupt Event Status Register	0x0000_0000
USB_FADDR	USB_BA+0x008	R/W	USB Device Function Address Register	0x0000_0000
USB_EPSTS	USB_BA+0x00C	R	USB Endpoint Status Register	0x0000_0000
USB_ATTR	USB_BA+0x010	R/W	USB Bus Status and Attribution Register	0x0000_0040
USB_FLDET	USB_BA+0x014	R	USB Floating Detected Register	0x0000_0000
USB_STBUFSEG	USB_BA+0x018	R/W	Setup Token Buffer Segmentation Register	0x0000_0000
USB_BUFSEG0	USB_BA+0x020	R/W	Endpoint 0 Buffer Segmentation Register	0x0000_0000
USB_MXPLD0	USB_BA+0x024	R/W	Endpoint 0 Maximal Payload Register	0x0000_0000
USB_CFG0	USB_BA+0x028	R/W	Endpoint 0 Configuration Register	0x0000_0000
USB_CFGP0	USB_BA+0x02C	R/W	Endpoint 0 Set Stall and Clear In/Out Ready Control Register	0x0000_0000
USB_BUFSEG1	USB_BA+0x030	R/W	Endpoint 1 Buffer Segmentation Register	0x0000_0000
USB_MXPLD1	USB_BA+0x034	R/W	Endpoint 1 Maximal Payload Register	0x0000_0000
USB_CFG1	USB_BA+0x038	R/W	Endpoint 1 Configuration Register	0x0000_0000
USB_CFGP1	USB_BA+0x03C	R/W	Endpoint 1 Set Stall and Clear In/Out Ready Control Register	0x0000_0000
USB_BUFSEG2	USB_BA+0x040	R/W	Endpoint 2 Buffer Segmentation Register	0x0000_0000
USB_MXPLD2	USB_BA+0x044	R/W	Endpoint 2 Maximal Payload Register	0x0000_0000
USB_CFG2	USB_BA+0x048	R/W	Endpoint 2 Configuration Register	0x0000_0000
USB_CFGP2	USB_BA+0x04C	R/W	Endpoint 2 Set Stall and Clear In/Out Ready Control Register	0x0000_0000
USB_BUFSEG3	USB_BA+0x050	R/W	Endpoint 3 Buffer Segmentation Register	0x0000_0000
USB_MXPLD3	USB_BA+0x054	R/W	Endpoint 3 Maximal Payload Register	0x0000_0000
USB_CFG3	USB_BA+0x058	R/W	Endpoint 3 Configuration Register	0x0000_0000
USB_CFGP3	USB_BA+0x05C	R/W	Endpoint 3 Set Stall and Clear In/Out Ready Control Register	0x0000_0000



USB_BUFSEG4	USB_BA+0x060	R/W	Endpoint 4 Buffer Segmentation Register	0x0000_0000
USB_MXPLD4	USB_BA+0x064	R/W	Endpoint 4 Maximal Payload Register	0x0000_0000
USB_CFG4	USB_BA+0x068	R/W	Endpoint 4 Configuration Register	0x0000_0000
USB_CFGP4	USB_BA+0x06C	R/W	Endpoint 4 Set Stall and Clear In/Out Ready Control Register	0x0000_0000
USB_BUFSEG5	USB_BA+0x070	R/W	Endpoint 5 Buffer Segmentation Register	0x0000_0000
USB_MXPLD5	USB_BA+0x074	R/W	Endpoint 5 Maximal Payload Register	0x0000_0000
USB_CFG5	USB_BA+0x078	R/W	Endpoint 5 Configuration Register	0x0000_0000
USB_CFGP5	USB_BA+0x07C	R/W	Endpoint 5 Set Stall and Clear In/Out Ready Control Register	0x0000_0000
USB_DRVSE0	USB_BA+0x090	R/W	USB Drive SE0 Control Register	0x0000_0001

Memory Type	Address	Size	Description
USB_BA = 0x4006_0000			
SRAM	USB_BA+0x100	512 Bytes	The SRAM is used for the entire endpoints buffer. Refer to section 5.4.4.7 for the endpoint SRAM structure and its description.
	~ USB_BA+0x2FF		



5.4.6 Register Description

USB Interrupt Enable Register (USB_INTEN)

Register	Offset	R/W	Description	Reset Value
USB_INTEN	USB_BA+0x000	R/W	USB Interrupt Enable Register	0x0000_0000

31	30	29	28	27	26	25	24
Reserved							
23	22	21	20	19	18	17	16
Reserved							
15	14	13	12	11	10	9	8
INNAK_EN	Reserved						WAKEUP_EN
7	6	5	4	3	2	1	0
Reserved				WAKEUP_IE	FLDET_IE	USB_IE	BUS_IE

Bits	Description	Description
[31:16]	Reserved	Reserved
[15]	INNAK_EN	<p>Active NAK Function and Its Status in IN Token</p> <p>1 = NAK status is updated to the endpoint status register, USB_EPSTS, when it is set to 1 and there is NAK response in IN token. It also enable the interrupt event when the device responds NAK after receiving IN token</p> <p>0 = NAK status is not updated to the endpoint status register when it is set to 0. It also disables the interrupt event when device responds to NAK after receiving the IN token.</p>
[14:9]	Reserved	Reserved
[8]	WAKEUP_EN	<p>Wake-up Function Enable</p> <p>1 = USB wake-up function Enabled.</p> <p>0 = USB wake-up function Disabled.</p>
[7:4]	Reserved	Reserved
[3]	WAKEUP_IE	<p>USB Wake-up Interrupt Enable</p> <p>1 = Wake-up Interrupt Enabled</p> <p>0 = Wake-up Interrupt Disabled</p>
[2]	FLDET_IE	<p>Floating Detected Interrupt Enable</p> <p>1 = Floating detect Interrupt Enabled.</p> <p>0 = Floating detect Interrupt Disabled.</p>
[1]	USB_IE	<p>USB Event Interrupt Enable</p> <p>1 = USB event interrupt Enabled.</p> <p>0 = USB event interrupt Disabled.</p>



[0]	BUS_IE	Bus Event Interrupt Enable 1 = BUS event interrupt Enabled. 0 = BUS event interrupt Disabled.
-----	---------------	--



USB Interrupt Event Status Register (USB_INTSTS)

This register is USB Interrupt Event Status register; clear by write '1' to the corresponding bit.

Register	Offset	R/W	Description	Reset Value
USB_INTSTS	USB_BA+0x004	R/W	USB Interrupt Event Status Register	0x0000_0000

31	30	29	28	27	26	25	24
SETUP		Reserved					
23	22	21	20	19	18	17	16
Reserved		EPEVT5	EPEVT4	EPEVT3	EPEVT2	EPEVT1	EPEVT0
15	14	13	12	11	10	9	8
Reserved							
7	6	5	4	3	2	1	0
Reserved				WAKEUP_ST S	FLDET_ST S	USB_ST S	BUS_ST S

Bits	Description
[31]	SETUP Setup Event Status 1 = Setup event occurred, cleared by write 1 to USB_INTSTS[31] 0 = No Setup event
[30:22]	Reserved
[21]	EPEVT5 Endpoint 5's USB Event Status 1 = USB event occurred on Endpoint 5, check USB_EPSTS[25:23] to know which kind of USB event was occurred, cleared by write 1 to USB_INTSTS[21] or USB_INTSTS[1] 0 = No event occurred in endpoint 5
[20]	EPEVT4 Endpoint 4's USB Event Status 1 = USB event occurred on Endpoint 4, check USB_EPSTS[22:20] to know which kind of USB event was occurred, cleared by write 1 to USB_INTSTS[20] or USB_INTSTS[1] 0 = No event occurred in endpoint 4
[19]	EPEVT3 Endpoint 3's USB Event Status 1 = USB event occurred on Endpoint 3, check USB_EPSTS[19:17] to know which kind of USB event was occurred, cleared by write 1 to USB_INTSTS[19] or USB_INTSTS[1] 0 = No event occurred in endpoint 3
[18]	EPEVT2 Endpoint 2's USB Event Status 1 = USB event occurred on Endpoint 2, check USB_EPSTS[16:14] to know which kind of USB event was occurred, cleared by write 1 to USB_INTSTS[18] or USB_INTSTS[1] 0 = No event occurred in endpoint 2



[17]	EPEVT1	<p>Endpoint 1's USB Event Status</p> <p>1 = USB event occurred on Endpoint 1, check USB_EPSTS[13:11] to know which kind of USB event was occurred, cleared by write 1 to USB_INTSTS[17] or USB_INTSTS[1]</p> <p>0 = No event occurred in endpoint 1</p>
[16]	EPEVT0	<p>Endpoint 0's USB Event Status</p> <p>1 = USB event occurred on Endpoint 0, check USB_EPSTS[10:8] to know which kind of USB event was occurred, cleared by write 1 to USB_INTSTS[16] or USB_INTSTS[1]</p> <p>0 = No event occurred in endpoint 0</p>
[15:4]	Reserved	Reserved
[3]	WAKEUP_STS	<p>Wake-up Interrupt Status</p> <p>1 = Wake-up event occurred, cleared by write 1 to USB_INTSTS[3]</p> <p>0 = No Wake-up event is occurred</p>
[2]	FLDET_STS	<p>Floating Detected Interrupt Status</p> <p>1 = There is attached/detached event in the USB bus and it is cleared by write 1 to USB_INTSTS[2].</p> <p>0 = There is not attached/detached event in the USB</p>
[1]	USB_STS	<p>USB event Interrupt Status</p> <p>The USB event includes the Setup Token, IN Token, OUT ACK, ISO IN, or ISO OUT events in the bus.</p> <p>1 = USB event occurred, check EPSTS0~5[2:0] to know which kind of USB event was occurred, cleared by write 1 to USB_INTSTS[1] or EPSTS0~5 and SETUP (USB_INTSTS[31])</p> <p>0 = No any USB event is occurred</p>
[0]	BUS_STS	<p>BUS Interrupt Status</p> <p>The BUS event means that there is one of the suspense or the resume function in the bus.</p> <p>1 = Bus event occurred; check USB_ATTR[3:0] to know which kind of bus event was occurred, cleared by write 1 to USB_INTSTS[0].</p> <p>0 = No any BUS event is occurred</p>



USB Device Function Address Register (USB_FADDR)

A seven-bit value uses as the address of a device on the USB BUS.

Register	Offset	R/W	Description	Reset Value
USB_FADDR	USB_BA+0x008	R/W	USB Device Function Address Register	0x0000_0000

31	30	29	28	27	26	25	24
Reserved							
23	22	21	20	19	18	17	16
Reserved							
15	14	13	12	11	10	9	8
Reserved							
7	6	5	4	3	2	1	0
Reserved	FADDR						

Bits	Description	
[31:7]	Reserved	Reserved
[6:0]	FADDR	USB device's Function Address



USB Endpoint Status Register (USB_EPSTS)

Register	Offset	R/W	Description	Reset Value
USB_EPSTS	USB_BA+0x00C	R	USB Endpoint Status Register	0x0000_0000

31	30	29	28	27	26	25	24
Reserved						EPSTS5[2:1]	
23	22	21	20	19	18	17	16
EPSTS5[0]	EPSTS4[2:0]			EPSTS3[2:0]			EPSTS2[2]
15	14	13	12	11	10	9	8
EPSTS2[1:0]		EPSTS1[2:0]			EPSTS0[2:0]		
7	6	5	4	3	2	1	0
OVERRUN	Reserved						

Bits	Description
[31:26]	Reserved Reserved
[25:23]	EPSTS5 Endpoint 5 Bus Status These bits are used to indicate the current status of this endpoint 000 = In ACK 001 = In NAK 010 = Out Packet Data0 ACK 110 = Out Packet Data1 ACK 011 = Setup ACK 111 = Isochronous transfer end
[22:20]	EPSTS4 Endpoint 4 Bus Status These bits are used to indicate the current status of this endpoint 000 = In ACK 001 = In NAK 010 = Out Packet Data0 ACK 110 = Out Packet Data1 ACK 011 = Setup ACK 111 = Isochronous transfer end
[19:17]	EPSTS3 Endpoint 3 Bus Status These bits are used to indicate the current status of this endpoint 000 = In ACK 001 = In NAK 010 = Out Packet Data0 ACK 110 = Out Packet Data1 ACK



		011 = Setup ACK 111 = Isochronous transfer end
[16:14]	EPSTS2	Endpoint 2 Bus Status These bits are used to indicate the current status of this endpoint 000 = In ACK 001 = In NAK 010 = Out Packet Data0 ACK 110 = Out Packet Data1 ACK 011 = Setup ACK 111 = Isochronous transfer end
[13:11]	EPSTS1	Endpoint 1 Bus Status These bits are used to indicate the current status of this endpoint 000 = In ACK 001 = In NAK 010 = Out Packet Data0 ACK 110 = Out Packet Data1 ACK 011 = Setup ACK 111 = Isochronous transfer end
[10:8]	EPSTS0	Endpoint 0 Bus Status These bits are used to indicate the current status of this endpoint 000 = In ACK 001 = In NAK 010 = Out Packet Data0 ACK 110 = Out Packet Data1 ACK 011 = Setup ACK 111 = Isochronous transfer end
[7]	OVERRUN	Overrun It indicates that the received data is over the maximum payload number or not. 1 = It indicates that the Out Data more than the Max Payload in MXPLD register or the Setup Data more than 8 Bytes 0 = No overrun
[6:0]	Reserved	Reserved



USB Bus Status and Attribution Register (USB_ATTR)

Register	Offset	R/W	Description	Reset Value
USB_ATTR	USB_BA+0x010	R/W	USB Bus Status and Attribution Register	0x0000_0040

31	30	29	28	27	26	25	24
Reserved							
23	22	21	20	19	18	17	16
Reserved							
15	14	13	12	11	10	9	8
Reserved					BYTEM	PWRDN	DPPU_EN
7	6	5	4	3	2	1	0
USB_EN	Reserved	RWAKEUP	PHY_EN	TIMEOUT	RESUME	SUSPEND	USBRST

Bits	Description	
[31:11]	Reserved	Reserved
[10]	BYTEM	CPU access USB SRAM Size Mode Select 1 = Byte Mode: The size of the transfer from CPU to USB SRAM can be Byte only. 0 = Word Mode: The size of the transfer from CPU to USB SRAM can be Word only.
[9]	PWRDN	Power down PHY Transceiver, low active 1 = Turn-on related circuit of PHY transceiver 0 = Power down related circuit of PHY transceiver
[8]	DPPU_EN	Pull-up resistor on USB_DP enable 1 = The pull-up resistor in USB_DP bus active 0 = Disabled the pull-up resistor in USB_DP bus
[7]	USB_EN	USB Controller Enable 1 = USB Controller Enabled 0 = USB Controller Disabled
[6]	Reserved	Reserved
[5]	RWAKEUP	Remote wake-up 1 = Force USB bus to K (USB_DP low, USB_DM: high) state, used for remote wake-up 0 = Release the USB bus from K state
[4]	PHY_EN	PHY Transceiver Function Enable 1 = PHY transceiver function Enabled 0 = PHY transceiver function Disabled
[3]	TIMEOUT	Time Out Status



		<p>1 = Bus no any response more than 18 bits time</p> <p>0 = No time out</p> <p>It is a read only bit.</p>
[2]	RESUME	<p>Resume Status</p> <p>1 = Resume from suspend</p> <p>0 = No bus resume</p> <p>It is a read only bit.</p>
[1]	SUSPEND	<p>Suspend Status</p> <p>1 = Bus idle more than 3ms, either cable is plugged off or host is sleeping</p> <p>0 = Bus no suspend</p> <p>It is a read only bit.</p>
[0]	USBRST	<p>USB Reset Status</p> <p>1 = Bus reset when SE0 (single-ended 0) more than 2.5us</p> <p>0 = Bus no reset</p> <p>It is a read only bit.</p>



Floating detection Register (USB FLDET)

Register	Offset	R/W	Description	Reset Value
USB_FLDET	USB_BA+0x014	R	USB Floating Detected Register	0x0000_0000

31	30	29	28	27	26	25	24
Reserved							
23	22	21	20	19	18	17	16
Reserved							
15	14	13	12	11	10	9	8
Reserved							
7	6	5	4	3	2	1	0
Reserved							FLDET

Bits	Description	
[31:1]	Reserved	Reserved
[0]	FLDET	Device Floating Detected 1 = When the controller is attached into the BUS, this bit will be set as 1 0 = The controller didn't attached into the USB host



Buffer Segmentation Register (USB_STBUFSEG)

For Setup token only.

Register	Offset	R/W	Description	Reset Value
USB_STBUFSEG	USB_BA+0x018	R/W	Setup Token Buffer Segmentation Register	0x0000_0000

31	30	29	28	27	26	25	24
Reserved							
23	22	21	20	19	18	17	16
Reserved							
15	14	13	12	11	10	9	8
Reserved							STBUFSEG[8]
7	6	5	4	3	2	1	0
STBUFSEG[7:3]					Reserved		

Bits	Description	
[31:9]	Reserved	Reserved
[8:3]	STBUFSEG	It is used to indicate the offset address for the Setup token with the USB SRAM starting address. The effective starting address is USB_SRAM address + { STBUFSEG[8:3], 3'b000} Where the USB_SRAM address = USB_BA+0x100h. Note: It is used for Setup token only.
[2:0]	Reserved	Reserved



Buffer Segmentation Register (USB_BUFSEGx)

Register	Offset	R/W	Description	Reset Value
USB_BUFSEG0	USB_BA+0x020	R/W	Endpoint 0 Buffer Segmentation Register	0x0000_0000
USB_BUFSEG1	USB_BA+0x030	R/W	Endpoint 1 Buffer Segmentation Register	0x0000_0000
USB_BUFSEG2	USB_BA+0x040	R/W	Endpoint 2 Buffer Segmentation Register	0x0000_0000
USB_BUFSEG3	USB_BA+0x050	R/W	Endpoint 3 Buffer Segmentation Register	0x0000_0000
USB_BUFSEG4	USB_BA+0x060	R/W	Endpoint 4 Buffer Segmentation Register	0x0000_0000
USB_BUFSEG5	USB_BA+0x070	R/W	Endpoint 5 Buffer Segmentation Register	0x0000_0000

31	30	29	28	27	26	25	24
Reserved							
23	22	21	20	19	18	17	16
Reserved							
15	14	13	12	11	10	9	8
Reserved							BUFSEG[8]
7	6	5	4	3	2	1	0
BUFSEG[7:3]					Reserved		

Bits	Description	
[31:9]	Reserved	Reserved
[8:3]	BUFSEG	It is used to indicate the offset address for each endpoint with the USB SRAM starting address. The effective starting address of the endpoint is USB_SRAM address + { BUFSEG[8:3], 3'b000} Where the USB_SRAM address = USB_BA+0x100h. Refer to section 5.4.4.7 for the endpoint SRAM structure and its description.
[2:0]	Reserved	Reserved



Maximal Payload Register (USB MXPLDx)

Register	Offset	R/W	Description	Reset Value
USB_MXPLD0	USB_BA+0x024	R/W	Endpoint 0 Maximal Payload Register	0x0000_0000
USB_MXPLD1	USB_BA+0x034	R/W	Endpoint 1 Maximal Payload Register	0x0000_0000
USB_MXPLD2	USB_BA+0x044	R/W	Endpoint 2 Maximal Payload Register	0x0000_0000
USB_MXPLD3	USB_BA+0x054	R/W	Endpoint 3 Maximal Payload Register	0x0000_0000
USB_MXPLD4	USB_BA+0x064	R/W	Endpoint 4 Maximal Payload Register	0x0000_0000
USB_MXPLD5	USB_BA+0x074	R/W	Endpoint 5 Maximal Payload Register	0x0000_0000

31	30	29	28	27	26	25	24
Reserved							
23	22	21	20	19	18	17	16
Reserved							
15	14	13	12	11	10	9	8
Reserved							MXPLD[8]
7	6	5	4	3	2	1	0
MXPLD[7:0]							

Bits	Description	
[31:9]	Reserved	Reserved
[8:0]	MXPLD	<p>Maximal Payload</p> <p>It is used to define the data length which is transmitted to host (IN token) or the actual data length which is received from the host (OUT token). It also used to indicate that the endpoint is ready to be transmitted in IN token or received in OUT token.</p> <p>(1). When the register is written by CPU, For IN token, the value of MXPLD is used to define the data length to be transmitted and indicate the data buffer is ready.</p> <p>For OUT token, it means that the controller is ready to receive data from the host and the value of MXPLD is the maximal data length comes from host.</p> <p>(2). When the register is read by CPU, For IN token, the value of MXPLD is indicated the data length be transmitted to host</p> <p>For OUT token, the value of MXPLD is indicated the actual data length receiving from host.</p> <p>Note that once MXPLD is written, the data packets will be transmitted/received immediately after IN/OUT token arrived.</p>



Configuration Register (USB_CFGx)

Register	Offset	R/W	Description	Reset Value
USB_CFG0	USB_BA+0x028	R/W	Endpoint 0 Configuration Register	0x0000_0000
USB_CFG1	USB_BA+0x038	R/W	Endpoint 1 Configuration Register	0x0000_0000
USB_CFG2	USB_BA+0x048	R/W	Endpoint 2 Configuration Register	0x0000_0000
USB_CFG3	USB_BA+0x058	R/W	Endpoint 3 Configuration Register	0x0000_0000
USB_CFG4	USB_BA+0x068	R/W	Endpoint 4 Configuration Register	0x0000_0000
USB_CFG5	USB_BA+0x078	R/W	Endpoint 5 Configuration Register	0x0000_0000

31	30	29	28	27	26	25	24
Reserved							
23	22	21	20	19	18	17	16
Reserved							
15	14	13	12	11	10	9	8
Reserved						CSTALL	Reserved
7	6	5	4	3	2	1	0
DSQ_SYNC	STATE		ISOCH	EP_NUM			

Bits	Description	
[31:10]	Reserved	Reserved
[9]	CSTALL	Clear STALL Response 1 = Clear the device to response STALL handshake in setup stage 0 = Disabled the device to clear the STALL handshake in setup stage
[8]	Reserved	Reserved
[7]	DSQ_SYNC	Data Sequence Synchronization 1 = DATA1 PID 0 = DATA0 PID It is used to specify the DATA0 or DATA1 PID in the following IN token transaction. HW will toggle automatically in IN token base on the bit.
[6:5]	STATE	Endpoint STATE 00 = Endpoint is disabled 01 = Out endpoint 10 = IN endpoint 11 = Undefined
[4]	ISOCH	Isochronous Endpoint



		<p>This bit is used to set the endpoint as Isochronous endpoint, no handshake.</p> <p>1 = Isochronous endpoint</p> <p>0 = No Isochronous endpoint</p>
[3:0]	EP_NUM	<p>Endpoint Number</p> <p>These bits are used to define the endpoint number of the current endpoint</p>



Extra Configuration Register (USB_CFGPx)

Register	Offset	R/W	Description	Reset Value
USB_CFGP0	USB_BA+0x02C	R/W	Endpoint 0 Set Stall and Clear In/Out Ready Control Register	0x0000_0000
USB_CFGP1	USB_BA+0x03C	R/W	Endpoint 1 Set Stall and Clear In/Out Ready Control Register	0x0000_0000
USB_CFGP2	USB_BA+0x04C	R/W	Endpoint 2 Set Stall and Clear In/Out Ready Control Register	0x0000_0000
USB_CFGP3	USB_BA+0x05C	R/W	Endpoint 3 Set Stall and Clear In/Out Ready Control Register	0x0000_0000
USB_CFGP4	USB_BA+0x06C	R/W	Endpoint 4 Set Stall and Clear In/Out Ready Control Register	0x0000_0000
USB_CFGP5	USB_BA+0x07C	R/W	Endpoint 5 Set Stall and Clear In/Out Ready Control Register	0x0000_0000

31	30	29	28	27	26	25	24
Reserved							
23	22	21	20	19	18	17	16
Reserved							
15	14	13	12	11	10	9	8
Reserved							
7	6	5	4	3	2	1	0
Reserved						SSTALL	CLRRDY

Bits	Description	
[31:2]	Reserved	Reserved
[1]	SSTALL	<p>Set STALL</p> <p>1 = Set the device to respond STALL automatically</p> <p>0 = The device to response STALL Disabled</p>
[0]	CLRRDY	<p>Clear Ready</p> <p>When the MXPLD register is set by user, it means that the endpoint is ready to transmit or receive data. If the user wants to turn off this transaction before the transaction start, users can set this bit to 1 to turn it off and it is auto clear to 0.</p> <p>For IN token, write '1' is used to clear the IN token had ready to transmit the data to USB.</p> <p>For OUT token, write '1' is used to clear the OUT token had ready to receive the data from USB.</p> <p>This bit is write 1 only and it is always 0 when it was read back.</p>



USB Drive SE0 Register (USB_DRVSE0)

Register	Offset	R/W	Description	Reset Value
USB_DRVSE0	USB_BA+0x090	R/W	USB Drive SE0 Control Register	0x0000_0001

31	30	29	28	27	26	25	24
Reserved							
23	22	21	20	19	18	17	16
Reserved							
15	14	13	12	11	10	9	8
Reserved							
7	6	5	4	3	2	1	0
Reserved							DRVSE0

Bits	Description
[31:1]	Reserved
[0]	<p>DRVSE0</p> <p>Drive Single Ended Zero in USB Bus</p> <p>The Single Ended Zero (SE0) is when both lines (USB_DP and USB_DM) are being pulled low.</p> <p>1 = Force USB PHY transceiver to drive SE0</p> <p>0 = None</p>



5.5 General Purpose I/O (GPIO)

5.5.1 Overview

The NuMicro™ NUC130/NUC140 has up to 80 General Purpose I/O pins that can be shared with other function pins depending on the chip configuration. These 80 pins are arranged in 5 ports named with GPIOA, GPIOB, GPIOC, GPIOD and GPIOE. Each port has maximum 16 pins. Each one of the 80 pins is independent and has the corresponding register bits to control the pin mode function and data.

The I/O type of each of I/O pins can be configured by software individually as input, output, open-drain or quasi-bidirectional mode. After reset, the I/O type of all pins stay in quasi-bidirectional mode and port data register GPIOx_DOUT[15:0] resets to 0x0000_FFFF. Each I/O pin has a very weak individual pull-up resistor which is about 110 K Ω ~300 K Ω for V_{DD} is from 5.0 V to 2.5 V.

5.5.2 Features

- Four I/O modes:
 - ◆ Quasi bi-direction
 - ◆ Push-Pull output
 - ◆ Open-Drain output
 - ◆ Input only with high impedance
- TTL/Schmitt trigger input selectable
- I/O pin configured as interrupt source with edge/level setting
- Supports High Driver and High Sink I/O mode

5.5.3 Functional Description

5.5.3.1 Input Mode Explanation

Set GPIOx_PMD (PMDn[1:0]) to 00b the GPIOx port [n] pin is in Input mode and the I/O pin is in tri-state (high impedance) without output drive capability. The GPIOx_PIN value reflects the status of the corresponding port pins.

5.5.3.2 Output Mode Explanation

Set GPIOx_PMD (PMDn[1:0]) to 01b the GPIOx port [n] pin is in Output mode and the I/O pin supports digital output function with source/sink current capability. The bit value in the corresponding bit [n] of GPIOx_DOUT is driven on the pin.

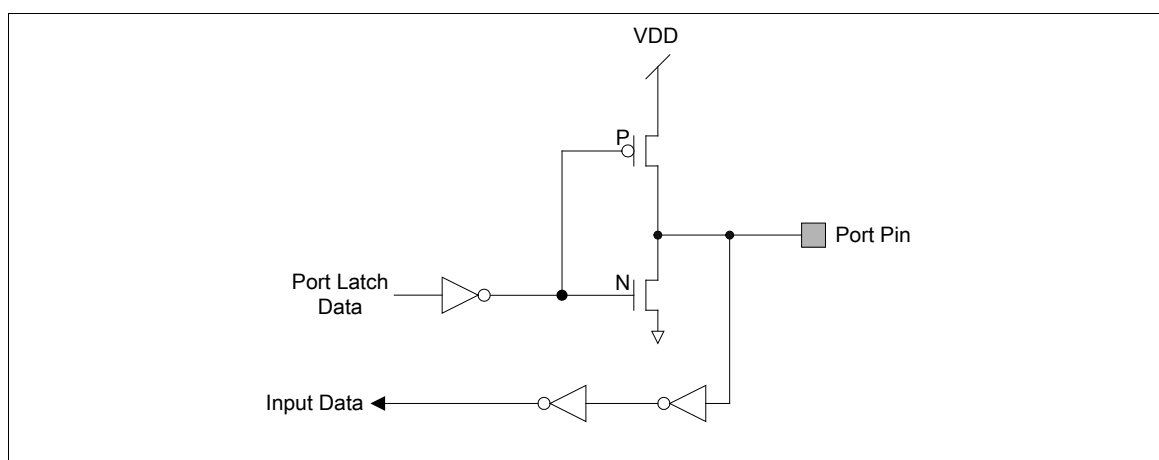

Figure 5-15 Push-Pull Output



5.5.3.3 Open-Drain Mode Explanation

Set GPIOx_PMD (PMDn[1:0]) to 10b the GPIOx port [n] pin is in Open-Drain mode and the digital output function of I/O pin supports only sink current capability, an additional pull-up resistor is needed for driving high state. If the bit value in the corresponding bit [n] of GPIOx_DOUT is 0, the pin drive a “low” output on the pin. If the bit value in the corresponding bit [n] of GPIOx_DOUT is 1, the pin output drives high that is controlled by external pull high resistor.

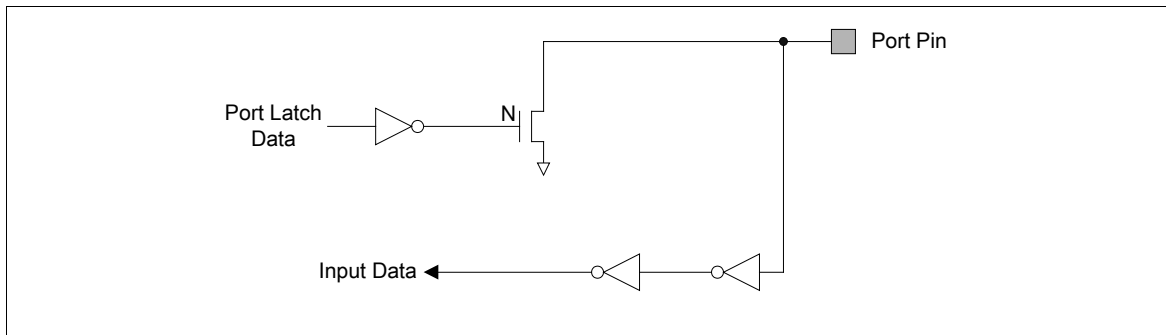

Figure 5-16 Open-Drain Output

5.5.3.4 Quasi-bidirectional Mode Explanation

Set GPIOx_PMD (PMDn[1:0]) to 11b the GPIOx port [n] pin is in Quasi-bidirectional mode and the I/O pin supports digital output and input function at the same time but the source current is only up to hundreds uA. Before the digital input function is performed the corresponding bit in GPIOx_DOUT must be set to 1. The quasi-bidirectional output is common on the 80C51 and most of its derivatives. If the bit value in the corresponding bit [n] of GPIOx_DOUT is 0, the pin drive a “low” output on the pin. If the bit value in the corresponding bit [n] of GPIOx_DOUT is 1, the pin will check the pin value. If pin value is high, no action takes. If pin state is low, then pin will drive strong high with 2 clock cycles on the pin and then disable the strong output drive and then the pin status is control by internal pull-up resistor. Note that the source current capability in quasi-bidirectional mode is only about 200 uA to 30 uA for V_{DD} is form 5.0 V to 2.5 V.

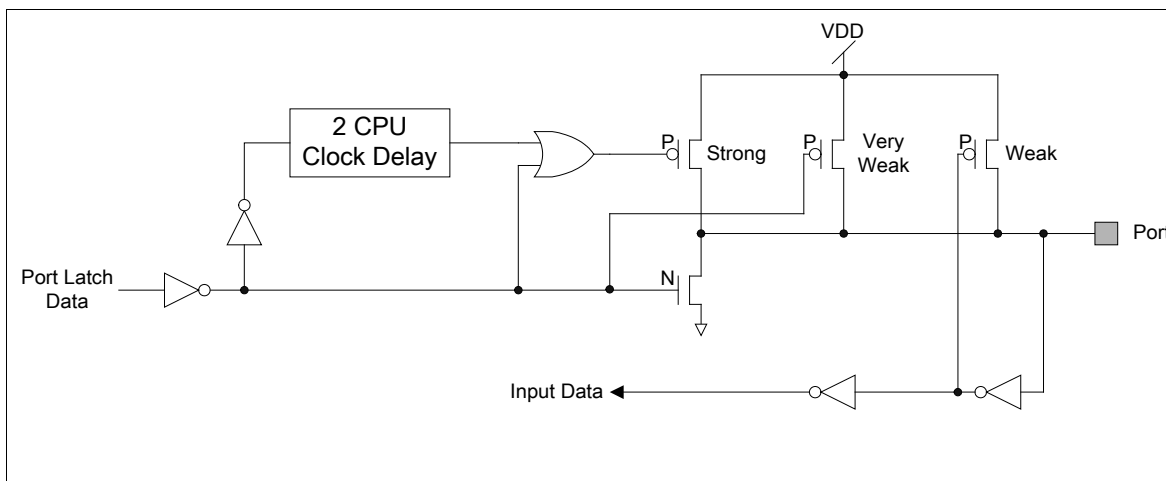

Figure 5-17 Quasi-bidirectional I/O Mode

5.5.3.5 GPIO Interrupt and wakeup function

Each GPIO pin can be set as chip interrupt source by setting correlative GPIOx_IEN bit and GPIOx_IMD. There are four types of interrupt condition can be selected: low level trigger, high level trigger, falling edge trigger and rising edge trigger. For edge trigger condition, user can enable input signal de-bounce function to prevent unexpected interrupt happened which caused by noise. The de-bounce clock source and sampling cycle can be set through DEBOUNCE register.

The GPIO can also be the chip wakeup source when chip enters Idle mode or Power-down mode. The setting of wakeup trigger condition is the same as GPIO interrupt trigger, but there are two things need to be noticed if using GPIO as chip wakeup source

1. To ensure the I/O status before entering Power-down mode

If using toggle GPIO to wakeup system, user must to make sure the I/O status before entering to idle mode or Power-down mode according to the relative wakeup settings.

For example, if configure the wakeup event occurred by I/O rising edge/high level trigger, user must make sure the I/O status of specified pin is at low level before entering to idle/Power-down mode; and if configure I/O falling edge/low level trigger to trigger a wakeup event, user must make sure the I/O status of specified pin is at high level before entering to Power-down mode.

2. To disable the specified I/O de-bounce function if necessary

If the specified wakeup GPIO with input signal de-bounce function, the de-bounce function must be disabled before system enters Power-down mode, otherwise system will encounter two GPIO interrupts when system wakeup (One is cause by wakeup function, the other one is caused by de-bounce function).



5.5.4 Register Map

R: read only, W: write only, R/W: both read and write

Register	Offset	R/W	Description	Reset Value
GP Base Address:				
GP_BA = 0x5000_4000				
GPIOA_PMD	GP_BA+0x000	R/W	GPIO Port A Pin I/O Mode Control	0xFFFF_FFFF
GPIOA_OFFD	GP_BA+0x004	R/W	GPIO Port A Pin Digital Input Path Disable Control	0x0000_0000
GPIOA_DOUT	GP_BA+0x008	R/W	GPIO Port A Data Output Value	0x0000_FFFF
GPIOA_DMASK	GP_BA+0x00C	R/W	GPIO Port A Data Output Write Mask	0XXXXX_0000
GPIOA_PIN	GP_BA+0x010	R	GPIO Port A Pin Value	0x0000_XXXX
GPIOA_DBEN	GP_BA+0x014	R/W	GPIO Port A De-bounce Enable	0XXXXX_0000
GPIOA_IMD	GP_BA+0x018	R/W	GPIO Port A Interrupt Mode Control	0XXXXX_0000
GPIOA_IEN	GP_BA+0x01C	R/W	GPIO Port A Interrupt Enable	0x0000_0000
GPIOA_ISRC	GP_BA+0x020	R/W	GPIO Port A Interrupt Source Flag	0XXXXX_XXXX
GPIOB_PMD	GP_BA+0x040	R/W	GPIO Port B Pin I/O Mode Control	0xFFFF_FFFF
GPIOB_OFFD	GP_BA+0x044	R/W	GPIO Port B Pin Digital Input Path Disable Control	0x0000_0000
GPIOB_DOUT	GP_BA+0x048	R/W	GPIO Port B Data Output Value	0x0000_FFFF
GPIOB_DMASK	GP_BA+0x04C	R/W	GPIO Port B Data Output Write Mask	0XXXXX_0000
GPIOB_PIN	GP_BA+0x050	R	GPIO Port B Pin Value	0x0000_XXXX
GPIOB_DBEN	GP_BA+0x054	R/W	GPIO Port B De-bounce Enable	0XXXXX_0000
GPIOB_IMD	GP_BA+0x058	R/W	GPIO Port B Interrupt Mode Control	0XXXXX_0000
GPIOB_IEN	GP_BA+0x05C	R/W	GPIO Port B Interrupt Enable	0x0000_0000
GPIOB_ISRC	GP_BA+0x060	R/W	GPIO Port B Interrupt Source Flag	0XXXXX_XXXX
GPIOC_PMD	GP_BA+0x080	R/W	GPIO Port C Pin I/O Mode Control	0xFFFF_FFFF
GPIOC_OFFD	GP_BA+0x084	R/W	GPIO Port C Pin Digital Input Path Disable Control	0x0000_0000
GPIOC_DOUT	GP_BA+0x088	R/W	GPIO Port C Data Output Value	0x0000_FFFF
GPIOC_DMASK	GP_BA+0x08C	R/W	GPIO Port C Data Output Write Mask	0XXXXX_0000
GPIOC_PIN	GP_BA+0x090	R	GPIO Port C Pin Value	0x0000_XXXX
GPIOC_DBEN	GP_BA+0x094	R/W	GPIO Port C De-bounce Enable	0XXXXX_0000
GPIOC_IMD	GP_BA+0x098	R/W	GPIO Port C Interrupt Mode Control	0XXXXX_0000
GPIOC_IEN	GP_BA+0x09C	R/W	GPIO Port C Interrupt Enable	0x0000_0000



Register	Offset	R/W	Description	Reset Value
GPIOC_ISRC	GP_BA+0x0A0	R/W	GPIO Port C Interrupt Source Flag	0xFFFF_FFFF
GPIOD_PMD	GP_BA+0x0C0	R/W	GPIO Port D Pin I/O Mode Control	0x0000_0000
GPIOD_OFFD	GP_BA+0x0C4	R/W	GPIO Port D Pin Digital Input Path Disable Control	0x0000_0000
GPIOD_DOUT	GP_BA+0x0C8	R/W	GPIO Port D Data Output Value	0x0000_FFFF
GPIOD_DMASK	GP_BA+0x0CC	R/W	GPIO Port D Data Output Write Mask	0xFFFF_0000
GPIOD_PIN	GP_BA+0x0D0	R	GPIO Port D Pin Value	0x0000_XXXX
GPIOD_DBEN	GP_BA+0x0D4	R/W	GPIO Port D De-bounce Enable	0xFFFF_0000
GPIOD_IMD	GP_BA+0x0D8	R/W	GPIO Port D Interrupt Mode Control	0xFFFF_0000
GPIOD_IEN	GP_BA+0x0DC	R/W	GPIO Port D Interrupt Enable	0x0000_0000
GPIOD_ISRC	GP_BA+0x0E0	R/W	GPIO Port D Interrupt Source Flag	0xFFFF_FFFF
GPIOE_PMD	GP_BA+0x100	R/W	GPIO Port E Pin I/O Mode Control	0x0000_0000
GPIOE_OFFD	GP_BA+0x104	R/W	GPIO Port E Pin Digital Input Path Disable Control	0x0000_0000
GPIOE_DOUT	GP_BA+0x108	R/W	GPIO Port E Data Output Value	0x0000_FFFF
GPIOE_DMASK	GP_BA+0x10C	R/W	GPIO Port E Data Output Write Mask	0xFFFF_0000
GPIOE_PIN	GP_BA+0x110	R	GPIO Port E Pin Value	0x0000_XXXX
GPIOE_DBEN	GP_BA+0x114	R/W	GPIO Port E De-bounce Enable	0xFFFF_0000
GPIOE_IMD	GP_BA+0x118	R/W	GPIO Port E Interrupt Mode Control	0xFFFF_0000
GPIOE_IEN	GP_BA+0x11C	R/W	GPIO Port E Interrupt Enable	0x0000_0000
GPIOE_ISRC	GP_BA+0x120	R/W	GPIO Port E Interrupt Source Flag	0xFFFF_FFFF
DBNCECON	GP_BA+0x180	R/W	De-bounce Cycle Control	0x0000_0020
PA0_PDIO	GP_BA+0x200	R/W	GPIO PA.0 Pin Data I/O	0x0000_0001
PA1_PDIO	GP_BA+0x204	R/W	GPIO PA.1 Pin Data I/O	0x0000_0001
PA2_PDIO	GP_BA+0x208	R/W	GPIO PA.2 Pin Data I/O	0x0000_0001
PA3_PDIO	GP_BA+0x20C	R/W	GPIO PA.3 Pin Data I/O	0x0000_0001
PA4_PDIO	GP_BA+0x210	R/W	GPIO PA.4 Pin Data I/O	0x0000_0001
PA5_PDIO	GP_BA+0x214	R/W	GPIO PA.5 Pin Data I/O	0x0000_0001
PA6_PDIO	GP_BA+0x218	R/W	GPIO PA.6 Pin Data I/O	0x0000_0001
PA7_PDIO	GP_BA+0x21C	R/W	GPIO PA.7 Pin Data I/O	0x0000_0001
PA8_PDIO	GP_BA+0x220	R/W	GPIO PA.8 Pin Data I/O	0x0000_0001



Register	Offset	R/W	Description	Reset Value
PA9_PDIO	GP_BA+0x224	R/W	GPIO PA.9 Pin Data I/O	0x0000_0001
PA10_PDIO	GP_BA+0x228	R/W	GPIO PA.10 Pin Data I/O	0x0000_0001
PA11_PDIO	GP_BA+0x22C	R/W	GPIO PA.11 Pin Data I/O	0x0000_0001
PA12_PDIO	GP_BA+0x230	R/W	GPIO PA.12 Pin Data I/O	0x0000_0001
PA13_PDIO	GP_BA+0x234	R/W	GPIO PA.13 Pin Data I/O	0x0000_0001
PA14_PDIO	GP_BA+0x238	R/W	GPIO PA.14 Pin Data I/O	0x0000_0001
PA15_PDIO	GP_BA+0x23C	R/W	GPIO PA.15 Pin Data I/O	0x0000_0001
PB0_PDIO	GP_BA+0x240	R/W	GPIO PB.0 Pin Data I/O	0x0000_0001
PB1_PDIO	GP_BA+0x244	R/W	GPIO PB.1 Pin Data I/O	0x0000_0001
PB2_PDIO	GP_BA+0x248	R/W	GPIO PB.2 Pin Data I/O	0x0000_0001
PB3_PDIO	GP_BA+0x24C	R/W	GPIO PB.3 Pin Data I/O	0x0000_0001
PB4_PDIO	GP_BA+0x250	R/W	GPIO PB.4 Pin Data I/O	0x0000_0001
PB5_PDIO	GP_BA+0x254	R/W	GPIO PB.5 Pin Data I/O	0x0000_0001
PB6_PDIO	GP_BA+0x258	R/W	GPIO PB.6 Pin Data I/O	0x0000_0001
PB7_PDIO	GP_BA+0x25C	R/W	GPIO PB.7 Pin Data I/O	0x0000_0001
PB8_PDIO	GP_BA+0x260	R/W	GPIO PB.8 Pin Data I/O	0x0000_0001
PB9_PDIO	GP_BA+0x264	R/W	GPIO PB.9 Pin Data I/O	0x0000_0001
PB10_PDIO	GP_BA+0x268	R/W	GPIO PB.10 Pin Data I/O	0x0000_0001
PB11_PDIO	GP_BA+0x26C	R/W	GPIO PB.11 Pin Data I/O	0x0000_0001
PB12_PDIO	GP_BA+0x270	R/W	GPIO PB.12 Pin Data I/O	0x0000_0001
PB13_PDIO	GP_BA+0x274	R/W	GPIO PB.13 Pin Data I/O	0x0000_0001
PB14_PDIO	GP_BA+0x278	R/W	GPIO PB.14 Pin Data I/O	0x0000_0001
PB15_PDIO	GP_BA+0x27C	R/W	GPIO PB.15 Pin Data I/O	0x0000_0001
PC0_PDIO	GP_BA+0x280	R/W	GPIO PC.0 Pin Data I/O	0x0000_0001
PC1_PDIO	GP_BA+0x284	R/W	GPIO PC.1 Pin Data I/O	0x0000_0001
PC2_PDIO	GP_BA+0x288	R/W	GPIO PC.2 Pin Data I/O	0x0000_0001
PC3_PDIO	GP_BA+0x28C	R/W	GPIO PC.3 Pin Data I/O	0x0000_0001
PC4_PDIO	GP_BA+0x290	R/W	GPIO PC.4 Pin Data I/O	0x0000_0001
PC5_PDIO	GP_BA+0x294	R/W	GPIO PC.5 Pin Data I/O	0x0000_0001



Register	Offset	R/W	Description	Reset Value
PC6_PDIO	GP_BA+0x298	R/W	GPIO PC.6 Pin Data I/O	0x0000_0001
PC7_PDIO	GP_BA+0x29C	R/W	GPIO PC.7 Pin Data I/O	0x0000_0001
PC8_PDIO	GP_BA+0x2A0	R/W	GPIO PC.8 Pin Data I/O	0x0000_0001
PC9_PDIO	GP_BA+0x2A4	R/W	GPIO PC.9 Pin Data I/O	0x0000_0001
PC10_PDIO	GP_BA+0x2A8	R/W	GPIO PC.10 Pin Data I/O	0x0000_0001
PC11_PDIO	GP_BA+0x2AC	R/W	GPIO PC.11 Pin Data I/O	0x0000_0001
PC12_PDIO	GP_BA+0x2B0	R/W	GPIO PC.12 Pin Data I/O	0x0000_0001
PC13_PDIO	GP_BA+0x2B4	R/W	GPIO PC.13 Pin Data I/O	0x0000_0001
PC14_PDIO	GP_BA+0x2B8	R/W	GPIO PC.14 Pin Data I/O	0x0000_0001
PC15_PDIO	GP_BA+0x2BC	R/W	GPIO PC.15 Pin Data I/O	0x0000_0001
PD0_PDIO	GP_BA+0x2C0	R/W	GPIO PD.0 Pin Data I/O	0x0000_0001
PD1_PDIO	GP_BA+0x2C4	R/W	GPIO PD.1 Pin Data I/O	0x0000_0001
PD2_PDIO	GP_BA+0x2C8	R/W	GPIO PD.2 Pin Data I/O	0x0000_0001
PD3_PDIO	GP_BA+0x2CC	R/W	GPIO PD.3 Pin Data I/O	0x0000_0001
PD4_PDIO	GP_BA+0x2D0	R/W	GPIO PD.4 Pin Data I/O	0x0000_0001
PD5_PDIO	GP_BA+0x2D4	R/W	GPIO PD.5 Pin Data I/O	0x0000_0001
PD6_PDIO	GP_BA+0x2D8	R/W	GPIO PD.6 Pin Data I/O	0x0000_0001
PD7_PDIO	GP_BA+0x2DC	R/W	GPIO PD.7 Pin Data I/O	0x0000_0001
PD8_PDIO	GP_BA+0x2E0	R/W	GPIO PD.8 Pin Data I/O	0x0000_0001
PD9_PDIO	GP_BA+0x2E4	R/W	GPIO PD.9 Pin Data I/O	0x0000_0001
PD10_PDIO	GP_BA+0x2E8	R/W	GPIO PD.10 Pin Data I/O	0x0000_0001
PD11_PDIO	GP_BA+0x2EC	R/W	GPIO PD.11 Pin Data I/O	0x0000_0001
PD12_PDIO	GP_BA+0x2F0	R/W	GPIO PD.12 Pin Data I/O	0x0000_0001
PD13_PDIO	GP_BA+0x2F4	R/W	GPIO PD.13 Pin Data I/O	0x0000_0001
PD14_PDIO	GP_BA+0x2F8	R/W	GPIO PD.14 Pin Data I/O	0x0000_0001
PD15_PDIO	GP_BA+0x2FC	R/W	GPIO PD.15 Pin Data I/O	0x0000_0001
PE0_PDIO	GP_BA+0x300	R/W	GPIO PE.0 Pin Data I/O	0x0000_0001
PE1_PDIO	GP_BA+0x304	R/W	GPIO PE.1 Pin Data I/O	0x0000_0001
PE2_PDIO	GP_BA+0x308	R/W	GPIO PE.2 Pin Data I/O	0x0000_0001



Register	Offset	R/W	Description	Reset Value
PE3_PDIO	GP_BA+0x30C	R/W	GPIO PE.3 Pin Data I/O	0x0000_0001
PE4_PDIO	GP_BA+0x310	R/W	GPIO PE.4 Pin Data I/O	0x0000_0001
PE5_PDIO	GP_BA+0x314	R/W	GPIO PE.5 Pin Data I/O	0x0000_0001
PE6_PDIO	GP_BA+0x318	R/W	GPIO PE.6 Pin Data I/O	0x0000_0001
PE7_PDIO	GP_BA+0x31C	R/W	GPIO PE.7 Pin Data I/O	0x0000_0001
PE8_PDIO	GP_BA+0x320	R/W	GPIO PE.8 Pin Data I/O	0x0000_0001
PE9_PDIO	GP_BA+0x324	R/W	GPIO PE.9 Pin Data I/O	0x0000_0001
PE10_PDIO	GP_BA+0x328	R/W	GPIO PE.10 Pin Data I/O	0x0000_0001
PE11_PDIO	GP_BA+0x32C	R/W	GPIO PE.11 Pin Data I/O	0x0000_0001
PE12_PDIO	GP_BA+0x330	R/W	GPIO PE.12 Pin Data I/O	0x0000_0001
PE13_PDIO	GP_BA+0x334	R/W	GPIO PE.13 Pin Data I/O	0x0000_0001
PE14_PDIO	GP_BA+0x338	R/W	GPIO PE.14 Pin Data I/O	0x0000_0001
PE15_PDIO	GP_BA+0x33C	R/W	GPIO PE.15 Pin Data I/O	0x0000_0001



5.5.5 Register Description

GPIO Port [A/B/C/D/E] I/O Mode Control (GPIOx_PMD)

Register	Offset	R/W	Description	Reset Value
GPIOA_PMD	GP_BA+0x000	R/W	GPIO Port A Pin I/O Mode Control	0xFFFF_FFFF
GPIOB_PMD	GP_BA+0x040	R/W	GPIO Port B Pin I/O Mode Control	0xFFFF_FFFF
GPIOC_PMD	GP_BA+0x080	R/W	GPIO Port C Pin I/O Mode Control	0xFFFF_FFFF
GIOD_PMD	GP_BA+0x0C0	R/W	GPIO Port D Pin I/O Mode Control	0xFFFF_FFFF
GPIOE_PMD	GP_BA+0x100	R/W	GPIO Port E Pin I/O Mode Control	0xFFFF_FFFF

31	30	29	28	27	26	25	24
PMD15		PMD14		PMD13		PMD12	
23	22	21	20	19	18	17	16
PMD11		PMD10		PMD9		PMD8	
15	14	13	12	11	10	9	8
PMD7		PMD6		PMD5		PMD4	
7	6	5	4	3	2	1	0
PMD3		PMD2		PMD1		PMD0	

Bits	Description	
[2n+1:2n] n=0,1..15	PMDn	<p>GPIOx I/O Pin[n] Mode Control</p> <p>Determine each I/O type of GPIOx pins.</p> <p>00 = GPIO port [n] pin is in INPUT mode</p> <p>01 = GPIO port [n] pin is in OUTPUT mode</p> <p>10 = GPIO port [n] pin is in Open-Drain mode</p> <p>11 = GPIO port [n] pin is in Quasi-bidirectional mode</p>



GPIO Port [A/B/C/D/E] Pin Digital Input Path Disable Control (GPIOx_OFFD)

Register	Offset	R/W	Description	Reset Value
GPIOA_OFFD	GP_BA+0x004	R/W	GPIO Port A Pin Digital Input Path Disable Control	0x0000_0000
GPIOB_OFFD	GP_BA+0x044	R/W	GPIO Port B Pin Digital Input Path Disable Control	0x0000_0000
GPIOC_OFFD	GP_BA+0x084	R/W	GPIO Port C Pin Digital Input Path Disable Control	0x0000_0000
GIOD_OFFD	GP_BA+0x0C4	R/W	GPIO Port D Pin Digital Input Path Disable Control	0x0000_0000
GPIOE_OFFD	GP_BA+0x104	R/W	GPIO Port E Pin Digital Input Path Disable Control	0x0000_0000

31	30	29	28	27	26	25	24
OFFD							
23	22	21	20	19	18	17	16
OFFD							
15	14	13	12	11	10	9	8
Reserved							
7	6	5	4	3	2	1	0
Reserved							

Bits	Description	
[31:16]	OFFD	<p>GPIOx Pin[n] Digital Input Path Disable Control</p> <p>Each of these bits is used to control if the digital input path of corresponding GPIO pin is disabled. If input is analog signal, users can disable GPIO digital input path to avoid creepage</p> <p>1 = I/O digital input path Disabled (digital input tied to low)</p> <p>0 = I/O digital input path Enabled</p>
[15:0]	Reserved	Reserved



GPIO Port [A/B/C/D/E] Data Output Value (GPIOx_DOUT)

Register	Offset	R/W	Description	Reset Value
GPIOA_DOUT	GP_BA+0x008	R/W	GPIO Port A Data Output Value	0x0000_FFFF
GPIOB_DOUT	GP_BA+0x048	R/W	GPIO Port B Data Output Value	0x0000_FFFF
GPIOC_DOUT	GP_BA+0x088	R/W	GPIO Port C Data Output Value	0x0000_FFFF
GIPOD_DOUT	GP_BA+0x0C8	R/W	GPIO Port D Data Output Value	0x0000_FFFF
GPIOE_DOUT	GP_BA+0x108	R/W	GPIO Port E Data Output Value	0x0000_FFFF

31	30	29	28	27	26	25	24
Reserved							
23	22	21	20	19	18	17	16
Reserved							
15	14	13	12	11	10	9	8
DOUT[15:8]							
7	6	5	4	3	2	1	0
DOUT[7:0]							

Bits	Description	
[31:16]	Reserved	Reserved
[n] n=0,1..15	DOUT	<p>GPIOx Pin[n] Output Value</p> <p>Each of these bits control the status of a GPIO pin when the GPIO pin is configured as output, open-drain and quasi-mode.</p> <p>1 = GPIO port [A/B/C/D/E] Pin[n] will drive High if the GPIO pin is configured as output, open-drain and quasi-mode.</p> <p>0 = GPIO port [A/B/C/D/E] Pin[n] will drive Low if the GPIO pin is configured as output, open-drain and quasi-mode.</p>



GPIO Port [A/B/C/D/E] Data Output Write Mask (GPIOx_DMASK)

Register	Offset	R/W	Description	Reset Value
GPIOA_DMASK	GP_BA+0x00C	R/W	GPIO Port A Data Output Write Mask	0xFFFF_0000
GPIOB_DMASK	GP_BA+0x04C	R/W	GPIO Port B Data Output Write Mask	0xFFFF_0000
GPIOC_DMASK	GP_BA+0x08C	R/W	GPIO Port C Data Output Write Mask	0xFFFF_0000
GIOD_DMASK	GP_BA+0x0CC	R/W	GPIO Port D Data Output Write Mask	0xFFFF_0000
GPIOE_DMASK	GP_BA+0x10C	R/W	GPIO Port E Data Output Write Mask	0xFFFF_0000

31	30	29	28	27	26	25	24
Reserved							
23	22	21	20	19	18	17	16
Reserved							
15	14	13	12	11	10	9	8
DMASK[15:8]							
7	6	5	4	3	2	1	0
DMASK[7:0]							

Bits	Description	
[31:16]	Reserved	Reserved
[n] n=0,1..15	DMASK	<p>Port [A/B/C/D/E] Data Output Write Mask</p> <p>These bits are used to protect the corresponding register of GPIOx_DOUT bit[n]. When set the DMASK bit[n] to 1, the corresponding GPIOx_DOUT[n] bit is protected. The write signal is masked, write data to the protect bit is ignored</p> <p>1 = The corresponding GPIOx_DOUT[n] bit is protected 0 = The corresponding GPIOx_DOUT[n] bit can be updated</p> <p>Note: This function only protect corresponding GPIOx_DOUT[n] bit, and will not protect corresponding bit control register (GPIOAx_DOUT, GPIOBx_DOUT, GPIOCx_DOUT, GIODx_DOUT, GPIOEx_DOUT).</p>



GPIO Port [A/B/C/D/E] Pin Value (GPIOx_PIN)

Register	Offset	R/W	Description	Reset Value
GPIOA_PIN	GP_BA+0x010	R	GPIO Port A Pin Value	0x0000_XXXX
GPIOB_PIN	GP_BA+0x050	R	GPIO Port B Pin Value	0x0000_XXXX
GPIOC_PIN	GP_BA+0x090	R	GPIO Port C Pin Value	0x0000_XXXX
GIOD_PIN	GP_BA+0x0D0	R	GPIO Port D Pin Value	0x0000_XXXX
GPIOE_PIN	GP_BA+0x110	R	GPIO Port E Pin Value	0x0000_XXXX

31	30	29	28	27	26	25	24
Reserved							
23	22	21	20	19	18	17	16
Reserved							
15	14	13	12	11	10	9	8
PIN[15:8]							
7	6	5	4	3	2	1	0
PIN[7:0]							

Bits	Description	
[31:16]	Reserved	Reserved
[n] n=0,1..15	PIN	Port [A/B/C/D/E] Pin Values Each bit of the register reflects the actual status of the respective GPIO pin. If bit is 1, it indicates the corresponding pin status is high, else the pin status is low.



GPIO Port [A/B/C/D/E] De-bounce Enable (GPIOx_DBEN)

Register	Offset	R/W	Description	Reset Value
GPIOA_DBEN	GP_BA+0x014	R/W	GPIO Port A De-bounce Enable	0xFFFF_0000
GPIOB_DBEN	GP_BA+0x054	R/W	GPIO Port B De-bounce Enable	0xFFFF_0000
GPIOC_DBEN	GP_BA+0x094	R/W	GPIO Port C De-bounce Enable	0xFFFF_0000
GIPOD_DBEN	GP_BA+0x0D4	R/W	GPIO Port D De-bounce Enable	0xFFFF_0000
GPIOE_DBEN	GP_BA+0x114	R/W	GPIO Port E De-bounce Enable	0xFFFF_0000

31	30	29	28	27	26	25	24
Reserved							
23	22	21	20	19	18	17	16
Reserved							
15	14	13	12	11	10	9	8
DBEN[15:8]							
7	6	5	4	3	2	1	0
DBEN[7:0]							

Bits	Description
[31:16]	Reserved
[n] n=0,1..15	<p>Port [A/B/C/D/E] Input Signal De-bounce Enable</p> <p>DBEN[n] used to enable the de-bounce function for each corresponding bit. If the input signal pulse width cannot be sampled by continuous two de-bounce sample cycle. The input signal transition is seen as the signal bounce and will not trigger the interrupt. The de-bounce clock source is controlled by DBNCECON[4], one de-bounce sample cycle is controlled by DBNCECON[3:0]</p> <p>1 = The bit[n] de-bounce function Enabled 0 = The bit[n] de-bounce function Disabled</p> <p>The de-bounce function is valid for edge triggered interrupt. If the interrupt mode is level triggered, the de-bounce enable bit is ignored.</p> <p>Note: It is recommended setting this bit to '0' if GPIO is chosen as power down wakeup source. If set this bit to '1', will cause GPIO to produce interrupt twice. One is caused by wake up event, the other one is caused by delayed de-bounce result.</p>



GPIO Port [A/B/C/D/E] Interrupt Mode Control (GPIOx IMD)

Register	Offset	R/W	Description	Reset Value
GPIOA_IMD	GP_BA+0x018	R/W	GPIO Port A Interrupt Mode Control	0xFFFF_0000
GPIOB_IMD	GP_BA+0x058	R/W	GPIO Port B Interrupt Mode Control	0xFFFF_0000
GPIOC_IMD	GP_BA+0x098	R/W	GPIO Port C Interrupt Mode Control	0xFFFF_0000
GIPOD_IMD	GP_BA+0x0D8	R/W	GPIO Port D Interrupt Mode Control	0xFFFF_0000
GPIOE_IMD	GP_BA+0x118	R/W	GPIO Port E Interrupt Mode Control	0xFFFF_0000

31	30	29	28	27	26	25	24
Reserved							
23	22	21	20	19	18	17	16
Reserved							
15	14	13	12	11	10	9	8
IMD[15:8]							
7	6	5	4	3	2	1	0
IMD[7:0]							

Bits	Description	
[31:16]	Reserved	Reserved
[n] n=0,1..15	IMD	<p>Port [A/B/C/D/E] Edge or Level Detection Interrupt Control</p> <p>IMD[n] is used to control the interrupt is by level trigger or by edge trigger. If the interrupt is by edge trigger, the trigger source can be controlled by de-bounce. If the interrupt is by level trigger, the input source is sampled by one HCLK clock and generates the interrupt.</p> <p>1 = Level trigger interrupt 0 = Edge trigger interrupt</p> <p>If set pin as the level trigger interrupt, then only one level can be set on the registers GPIOx_IEN. If set both the level to trigger interrupt, the setting is ignored and no interrupt will occur</p> <p>The de-bounce function is valid for edge triggered interrupt. If the interrupt mode is level triggered, the de-bounce enable bit is ignored.</p>



GPIO Port [A/B/C/D] Interrupt Enable Control (GPIOx_IEN)

Register	Offset	R/W	Description	Reset Value
GPIOA_IEN	GP_BA+0x01C	R/W	GPIO Port A Interrupt Enable	0x0000_0000
GPIOB_IEN	GP_BA+0x05C	R/W	GPIO Port B Interrupt Enable	0x0000_0000
GPIOC_IEN	GP_BA+0x09C	R/W	GPIO Port C Interrupt Enable	0x0000_0000
GIPOD_IEN	GP_BA+0x0DC	R/W	GPIO Port D Interrupt Enable	0x0000_0000
GPIOE_IEN	GP_BA+0x11C	R/W	GPIO Port E Interrupt Enable	0x0000_0000

31	30	29	28	27	26	25	24
IR_EN[15:8]							
23	22	21	20	19	18	17	16
IR_EN[7:0]							
15	14	13	12	11	10	9	8
IF_EN[15:8]							
7	6	5	4	3	2	1	0
IF_EN[7:0]							

Bits	Description
[n+16] n=0,1..15	<p>Port [A/B/C/D/E] Interrupt Enable by Input Rising Edge or Input Level High</p> <p>IR_EN[n] used to enable the interrupt for each of the corresponding input GPIO_PIN[n]. Set bit to 1 also enable the pin wake-up function</p> <p>When set the IR_EN[n] bit to 1:</p> <p>If the interrupt is level trigger, the input PIN[n] state at level “high” will generate the interrupt.</p> <p>If the interrupt is edge trigger, the input PIN[n] state change from “low-to-high” will generate the interrupt.</p> <p>1 = PIN[n] level-high or low-to-high interrupt Enabled 0 = PIN[n] level-high or low-to-high interrupt Disabled</p>
[n] n=0,1..15	<p>Port [A/B/C/D/E] Interrupt Enable by Input Falling Edge or Input Level Low</p> <p>IF_EN[n] used to enable the interrupt for each of the corresponding input GPIO_PIN[n]. Set bit to 1 also enable the pin wake-up function</p> <p>When set the IF_EN[n] bit to 1:</p> <p>If the interrupt is level trigger, the input PIN[n] state at level “low” will generate the interrupt.</p> <p>If the interrupt is edge trigger, the input PIN[n] state change from “high-to-low” will generate the interrupt.</p> <p>1 = PIN[n] state low-level or high-to-low change interrupt Enabled 0 = PIN[n] state low-level or high-to-low change interrupt Disabled</p>



GPIO Port [A/B/C/D/E] Interrupt Source Flag (GPIOx_ISRC)

Register	Offset	R/W	Description	Reset Value
GPIOA_ISRC	GP_BA+0x020	R/W	GPIO Port A Interrupt Source Flag	0xFFFF_FFFF
GPIOB_ISRC	GP_BA+0x060	R/W	GPIO Port B Interrupt Source Flag	0xFFFF_FFFF
GPIOC_ISRC	GP_BA+0x0A0	R/W	GPIO Port C Interrupt Source Flag	0xFFFF_FFFF
GIOD_ISRC	GP_BA+0x0E0	R/W	GPIO Port D Interrupt Source Flag	0xFFFF_FFFF
GPIOE_ISRC	GP_BA+0x120	R/W	GPIO Port E Interrupt Source Flag	0xFFFF_FFFF

31	30	29	28	27	26	25	24
Reserved							
23	22	21	20	19	18	17	16
Reserved							
15	14	13	12	11	10	9	8
ISRC[15:8]							
7	6	5	4	3	2	1	0
ISRC[7:0]							

Bits	Description	
[31:16]	Reserved	Reserved
[n] n=0,1..15	ISRC	<p>Port [A/B/C/D/E] Interrupt Source Flag</p> <p>Read :</p> <p>1 = Indicates GPIOx[n] generate an interrupt 0 = No interrupt at GPIOx[n]</p> <p>Write :</p> <p>1= Clear the correspond pending interrupt 0= No action</p>



Interrupt De-bounce Cycle Control (DBNCECON)

Register	Offset	R/W	Description	Reset Value
DBNCECON	GP_BA+0x180	R/W	De-bounce Cycle Control	0x0000_0020

31	30	29	28	27	26	25	24
Reserved							
23	22	21	20	19	18	17	16
Reserved							
15	14	13	12	11	10	9	8
Reserved							
7	6	5	4	3	2	1	0
Reserved		ICLK_ON	DBCLKSRC	DBCLKSEL			

Bits	Description																									
[5]	ICLK_ON	<p>Interrupt clock On mode</p> <p>1 = All I/O pins edge detection circuit is always active after reset.</p> <p>0 = Edge detection circuit is active only if the I/O pin corresponding to GPIOx_IEN bit is set to 1.</p> <p>It is recommended to turn off this bit to save system power, if on special application concern.</p>																								
[4]	DBCLKSRC	<p>De-bounce counter clock source select</p> <p>1 = De-bounce counter clock source is the internal 10 kHz low speed oscillator</p> <p>0 = De-bounce counter clock source is the HCLK</p>																								
[3:0]	DBCLKSEL	<p>De-bounce sampling cycle selection</p> <table border="1" style="width: 100%; border-collapse: collapse;"> <thead> <tr> <th>DBCLKSEL</th> <th>Description</th> </tr> </thead> <tbody> <tr><td>0</td><td>Sample interrupt input once per 1 clocks</td></tr> <tr><td>1</td><td>Sample interrupt input once per 2 clocks</td></tr> <tr><td>2</td><td>Sample interrupt input once per 4 clocks</td></tr> <tr><td>3</td><td>Sample interrupt input once per 8 clocks</td></tr> <tr><td>4</td><td>Sample interrupt input once per 16 clocks</td></tr> <tr><td>5</td><td>Sample interrupt input once per 32 clocks</td></tr> <tr><td>6</td><td>Sample interrupt input once per 64 clocks</td></tr> <tr><td>7</td><td>Sample interrupt input once per 128 clocks</td></tr> <tr><td>8</td><td>Sample interrupt input once per 256 clocks</td></tr> <tr><td>9</td><td>Sample interrupt input once per 2*256 clocks</td></tr> <tr><td>10</td><td>Sample interrupt input once per 4*256clocks</td></tr> </tbody> </table>	DBCLKSEL	Description	0	Sample interrupt input once per 1 clocks	1	Sample interrupt input once per 2 clocks	2	Sample interrupt input once per 4 clocks	3	Sample interrupt input once per 8 clocks	4	Sample interrupt input once per 16 clocks	5	Sample interrupt input once per 32 clocks	6	Sample interrupt input once per 64 clocks	7	Sample interrupt input once per 128 clocks	8	Sample interrupt input once per 256 clocks	9	Sample interrupt input once per 2*256 clocks	10	Sample interrupt input once per 4*256clocks
DBCLKSEL	Description																									
0	Sample interrupt input once per 1 clocks																									
1	Sample interrupt input once per 2 clocks																									
2	Sample interrupt input once per 4 clocks																									
3	Sample interrupt input once per 8 clocks																									
4	Sample interrupt input once per 16 clocks																									
5	Sample interrupt input once per 32 clocks																									
6	Sample interrupt input once per 64 clocks																									
7	Sample interrupt input once per 128 clocks																									
8	Sample interrupt input once per 256 clocks																									
9	Sample interrupt input once per 2*256 clocks																									
10	Sample interrupt input once per 4*256clocks																									



		11	Sample interrupt input once per 8*256 clocks
		12	Sample interrupt input once per 16*256 clocks
		13	Sample interrupt input once per 32*256 clocks
		14	Sample interrupt input once per 64*256 clocks
		15	Sample interrupt input once per 128*256 clocks



GPIO Px.n Pin Data I/O (Pxn_PDIO)

Register	Offset	R/W	Description	Reset Value
PA0_PDIO	GP_BA+0x200	R/W	GPIO PA.0 Pin Data I/O	0x0000_0001
PA1_PDIO	GP_BA+0x204	R/W	GPIO PA.1 Pin Data I/O	0x0000_0001
PA2_PDIO	GP_BA+0x208	R/W	GPIO PA.2 Pin Data I/O	0x0000_0001
PA3_PDIO	GP_BA+0x20C	R/W	GPIO PA.3 Pin Data I/O	0x0000_0001
PA4_PDIO	GP_BA+0x210	R/W	GPIO PA.4 Pin Data I/O	0x0000_0001
PA5_PDIO	GP_BA+0x214	R/W	GPIO PA.5 Pin Data I/O	0x0000_0001
PA6_PDIO	GP_BA+0x218	R/W	GPIO PA.6 Pin Data I/O	0x0000_0001
PA7_PDIO	GP_BA+0x21C	R/W	GPIO PA.7 Pin Data I/O	0x0000_0001
PA8_PDIO	GP_BA+0x220	R/W	GPIO PA.8 Pin Data I/O	0x0000_0001
PA9_PDIO	GP_BA+0x224	R/W	GPIO PA.9 Pin Data I/O	0x0000_0001
PA10_PDIO	GP_BA+0x228	R/W	GPIO PA.10 Pin Data I/O	0x0000_0001
PA11_PDIO	GP_BA+0x22C	R/W	GPIO PA.11 Pin Data I/O	0x0000_0001
PA12_PDIO	GP_BA+0x230	R/W	GPIO PA.12 Pin Data I/O	0x0000_0001
PA13_PDIO	GP_BA+0x234	R/W	GPIO PA.13 Pin Data I/O	0x0000_0001
PA14_PDIO	GP_BA+0x238	R/W	GPIO PA.14 Pin Data I/O	0x0000_0001
PA15_PDIO	GP_BA+0x23C	R/W	GPIO PA.15 Pin Data I/O	0x0000_0001
PB0_PDIO	GP_BA+0x240	R/W	GPIO PB.0 Pin Data I/O	0x0000_0001
PB1_PDIO	GP_BA+0x244	R/W	GPIO PB.1 Pin Data I/O	0x0000_0001
PB2_PDIO	GP_BA+0x248	R/W	GPIO PB.2 Pin Data I/O	0x0000_0001
PB3_PDIO	GP_BA+0x24C	R/W	GPIO PB.3 Pin Data I/O	0x0000_0001
PB4_PDIO	GP_BA+0x250	R/W	GPIO PB.4 Pin Data I/O	0x0000_0001
PB5_PDIO	GP_BA+0x254	R/W	GPIO PB.5 Pin Data I/O	0x0000_0001
PB6_PDIO	GP_BA+0x258	R/W	GPIO PB.6 Pin Data I/O	0x0000_0001
PB7_PDIO	GP_BA+0x25C	R/W	GPIO PB.7 Pin Data I/O	0x0000_0001
PB8_PDIO	GP_BA+0x260	R/W	GPIO PB.8 Pin Data I/O	0x0000_0001
PB9_PDIO	GP_BA+0x264	R/W	GPIO PB.9 Pin Data I/O	0x0000_0001
PB10_PDIO	GP_BA+0x268	R/W	GPIO PB.10 Pin Data I/O	0x0000_0001
PB11_PDIO	GP_BA+0x26C	R/W	GPIO PB.11 Pin Data I/O	0x0000_0001



PB12_PDIO	GP_BA+0x270	R/W	GPIO PB.12 Pin Data I/O	0x0000_0001
PB13_PDIO	GP_BA+0x274	R/W	GPIO PB.13 Pin Data I/O	0x0000_0001
PB14_PDIO	GP_BA+0x278	R/W	GPIO PB.14 Pin Data I/O	0x0000_0001
PB15_PDIO	GP_BA+0x27C	R/W	GPIO PB.15 Pin Data I/O	0x0000_0001
PC0_PDIO	GP_BA+0x280	R/W	GPIO PC.0 Pin Data I/O	0x0000_0001
PC1_PDIO	GP_BA+0x284	R/W	GPIO PC.1 Pin Data I/O	0x0000_0001
PC2_PDIO	GP_BA+0x288	R/W	GPIO PC.2 Pin Data I/O	0x0000_0001
PC3_PDIO	GP_BA+0x28C	R/W	GPIO PC.3 Pin Data I/O	0x0000_0001
PC4_PDIO	GP_BA+0x290	R/W	GPIO PC.4 Pin Data I/O	0x0000_0001
PC5_PDIO	GP_BA+0x294	R/W	GPIO PC.5 Pin Data I/O	0x0000_0001
PC6_PDIO	GP_BA+0x298	R/W	GPIO PC.6 Pin Data I/O	0x0000_0001
PC7_PDIO	GP_BA+0x29C	R/W	GPIO PC.7 Pin Data I/O	0x0000_0001
PC8_PDIO	GP_BA+0x2A0	R/W	GPIO PC.8 Pin Data I/O	0x0000_0001
PC9_PDIO	GP_BA+0x2A4	R/W	GPIO PC.9 Pin Data I/O	0x0000_0001
PC10_PDIO	GP_BA+0x2A8	R/W	GPIO PC.10 Pin Data I/O	0x0000_0001
PC11_PDIO	GP_BA+0x2AC	R/W	GPIO PC.11 Pin Data I/O	0x0000_0001
PC12_PDIO	GP_BA+0x2B0	R/W	GPIO PC.12 Pin Data I/O	0x0000_0001
PC13_PDIO	GP_BA+0x2B4	R/W	GPIO PC.13 Pin Data I/O	0x0000_0001
PC14_PDIO	GP_BA+0x2B8	R/W	GPIO PC.14 Pin Data I/O	0x0000_0001
PC15_PDIO	GP_BA+0x2BC	R/W	GPIO PC.15 Pin Data I/O	0x0000_0001
PD0_PDIO	GP_BA+0x2C0	R/W	GPIO PD.0 Pin Data I/O	0x0000_0001
PD1_PDIO	GP_BA+0x2C4	R/W	GPIO PD.1 Pin Data I/O	0x0000_0001
PD2_PDIO	GP_BA+0x2C8	R/W	GPIO PD.2 Pin Data I/O	0x0000_0001
PD3_PDIO	GP_BA+0x2CC	R/W	GPIO PD.3 Pin Data I/O	0x0000_0001
PD4_PDIO	GP_BA+0x2D0	R/W	GPIO PD.4 Pin Data I/O	0x0000_0001
PD5_PDIO	GP_BA+0x2D4	R/W	GPIO PD.5 Pin Data I/O	0x0000_0001
PD6_PDIO	GP_BA+0x2D8	R/W	GPIO PD.6 Pin Data I/O	0x0000_0001
PD7_PDIO	GP_BA+0x2DC	R/W	GPIO PD.7 Pin Data I/O	0x0000_0001
PD8_PDIO	GP_BA+0x2E0	R/W	GPIO PD.8 Pin Data I/O	0x0000_0001



PD9_PDIO	GP_BA+0x2E4	R/W	GPIO PD.9 Pin Data I/O	0x0000_0001
PD10_PDIO	GP_BA+0x2E8	R/W	GPIO PD.10 Pin Data I/O	0x0000_0001
PD11_PDIO	GP_BA+0x2EC	R/W	GPIO PD.11 Pin Data I/O	0x0000_0001
PD12_PDIO	GP_BA+0x2F0	R/W	GPIO PD.12 Pin Data I/O	0x0000_0001
PD13_PDIO	GP_BA+0x2F4	R/W	GPIO PD.13 Pin Data I/O	0x0000_0001
PD14_PDIO	GP_BA+0x2F8	R/W	GPIO PD.14 Pin Data I/O	0x0000_0001
PD15_PDIO	GP_BA+0x2FC	R/W	GPIO PD.15 Pin Data I/O	0x0000_0001
PE0_PDIO	GP_BA+0x300	R/W	GPIO PE.0 Pin Data I/O	0x0000_0001
PE1_PDIO	GP_BA+0x304	R/W	GPIO PE.1 Pin Data I/O	0x0000_0001
PE2_PDIO	GP_BA+0x308	R/W	GPIO PE.2 Pin Data I/O	0x0000_0001
PE3_PDIO	GP_BA+0x30C	R/W	GPIO PE.3 Pin Data I/O	0x0000_0001
PE4_PDIO	GP_BA+0x310	R/W	GPIO PE.4 Pin Data I/O	0x0000_0001
PE5_PDIO	GP_BA+0x314	R/W	GPIO PE.5 Pin Data I/O	0x0000_0001
PE6_PDIO	GP_BA+0x318	R/W	GPIO PE.6 Pin Data I/O	0x0000_0001
PE7_PDIO	GP_BA+0x31C	R/W	GPIO PE.7 Pin Data I/O	0x0000_0001
PE8_PDIO	GP_BA+0x320	R/W	GPIO PE.8 Pin Data I/O	0x0000_0001
PE9_PDIO	GP_BA+0x324	R/W	GPIO PE.9 Pin Data I/O	0x0000_0001
PE10_PDIO	GP_BA+0x328	R/W	GPIO PE.10 Pin Data I/O	0x0000_0001
PE11_PDIO	GP_BA+0x32C	R/W	GPIO PE.11 Pin Data I/O	0x0000_0001
PE12_PDIO	GP_BA+0x330	R/W	GPIO PE.12 Pin Data I/O	0x0000_0001
PE13_PDIO	GP_BA+0x334	R/W	GPIO PE.13 Pin Data I/O	0x0000_0001
PE14_PDIO	GP_BA+0x338	R/W	GPIO PE.14 Pin Data I/O	0x0000_0001
PE15_PDIO	GP_BA+0x33C	R/W	GPIO PE.15 Pin Data I/O	0x0000_0001

Note: x = A/B/C/D/E and n = 0~15

31	30	29	28	27	26	25	24
Reserved							
23	22	21	20	19	18	17	16
Reserved							
15	14	13	12	11	10	9	8
Reserved							

7	6	5	4	3	2	1	0
Reserved							Pxn_PDIO

Bits	Description
[0]	<p>Pxn_PDIO</p> <p>GPIO Px.n Pin Data I/O</p> <p>Write this bit can control one GPIO pin output value</p> <p>1 = Set corresponding GPIO pin to high</p> <p>0 = Set corresponding GPIO pin to low</p> <p>Read this register to get GPIO pin status.</p> <p>For example: write PA0_PDIO will reflect the written value to bit GPIOA_DOUT[0], read PA0_PDIO will return the value of GPIOA_PIN[0]</p> <p>Note: The write operation will not be affected by register GPIOx_DMASK</p>

5.6 I²C Serial Interface Controller (Master/Slave) (I²C)

5.6.1 Overview

I²C is a two-wire, bi-directional serial bus that provides a simple and efficient method of data exchange between devices. The I²C standard is a true multi-master bus including collision detection and arbitration that prevents data corruption if two or more masters attempt to control the bus simultaneously.

Data is transferred between a Master and a Slave synchronously to SCL on the SDA line on a byte-by-byte basis. Each data byte is 8-bit long. There is one SCL clock pulse for each data bit with the MSB being transmitted first. An acknowledge bit follows each transferred byte. Each bit is sampled during the high period of SCL; therefore, the SDA line may be changed only during the low period of SCL and must be held stable during the high period of SCL. A transition on the SDA line while SCL is high is interpreted as a command (START or STOP). Please refer to Figure 5-18 for more detailed I²C BUS Timing.

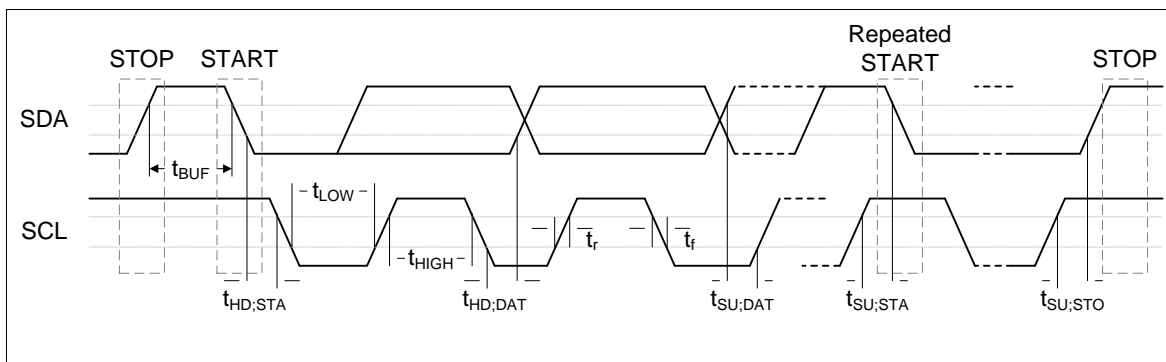

Figure 5-18 I²C Bus Timing

The device's on-chip I²C logic provides the serial interface that meets the I²C bus standard mode specification. The I²C port handles byte transfers autonomously. To enable this port, the bit ENS1 in I2CON should be set to '1'. The I²C H/W interfaces to the I²C bus via two pins: SDA and SCL.



Pull up resistor is needed for I²C operation as these are open drain pins. When the I/O pins are used as I²C port, user must set the pins function to I²C in advance.

5.6.2 Features

The I²C bus uses two wires (SDA and SCL) to transfer information between devices connected to the bus. The main features of the bus are:

- Master/Slave mode
- Bidirectional data transfer between masters and slaves
- Multi-master bus (no central master)
- Arbitration between simultaneously transmitting masters without corruption of serial data on the bus
- Serial clock synchronization allows devices with different bit rates to communicate via one serial bus
- Serial clock synchronization can be used as a handshake mechanism to suspend and resume serial transfer
- Built-in a 14-bit time-out counter will request the I²C interrupt if the I²C bus hangs up and timer-out counter overflows.
- External pull-up are needed for high output
- Programmable clocks allow versatile rate control
- Supports 7-bit addressing mode
- I²C-bus controllers support multiple address recognition (Four slave address with mask option)



5.6.3 Functional Description

5.6.3.1 I²C Protocol

Normally, a standard communication consists of four parts:

- 1) START or Repeated START signal generation
- 2) Slave address and R/W bit transfer
- 3) Data transfer
- 4) STOP signal generation

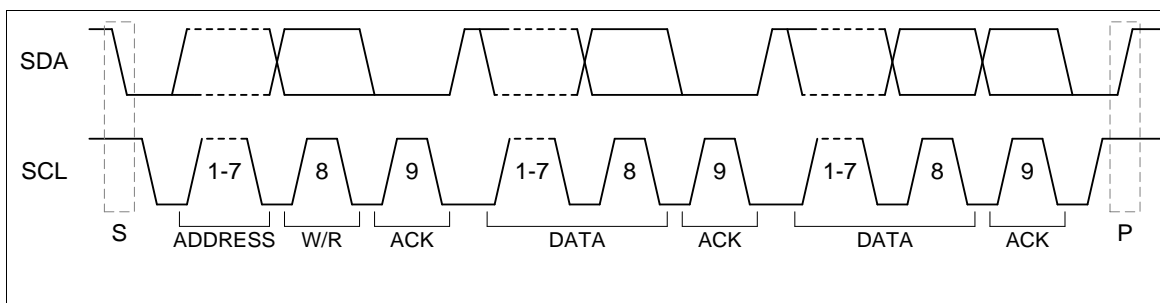

Figure 5-19 I²C Protocol

5.6.3.2 Data transfer on the I²C-bus

錯誤! 找不到參照來源。 shows a master transmits data to slave. A master addresses a slave with a 7-bit address and 1-bit write index to denote master wants to transmit data to slave. The master keep transmitting data after slave returns acknowledge to master.

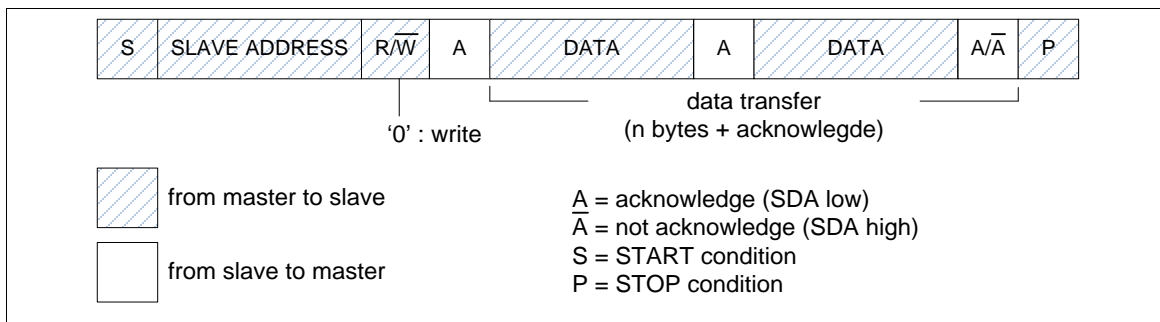

Figure 5-20 Master Transmits Data to Slave

錯誤! 找不到參照來源。 shows a master read data from slave. A master addresses a slave with a 7-bit address and 1-bit read index to denote master wants to read data from slave. The slave will start transmitting data after slave returns acknowledge to master.

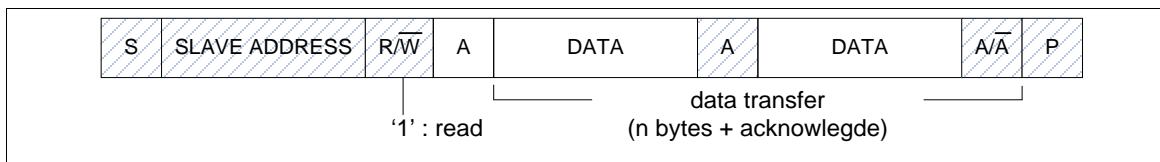

Figure 5-21 Master Reads Data from Slave

5.6.3.3 START or Repeated START signal

When the bus is free/idle, meaning no master device is engaging the bus (both SCL and SDA lines are high), a master can initiate a transfer by sending a START signal. A START signal, usually referred to as the S-bit, is defined as a HIGH to LOW transition on the SDA line while SCL is HIGH. The START signal denotes the beginning of a new data transfer.

A Repeated START (Sr) is no STOP signal between two START signals. The master uses this method to communicate with another slave or the same slave in a different transfer direction (e.g. from writing to a device to reading from a device) without releasing the bus.

STOP signal

The master can terminate the communication by generating a STOP signal. A STOP signal, usually referred to as the P-bit, is defined as a LOW to HIGH transition on the SDA line while SCL is HIGH.

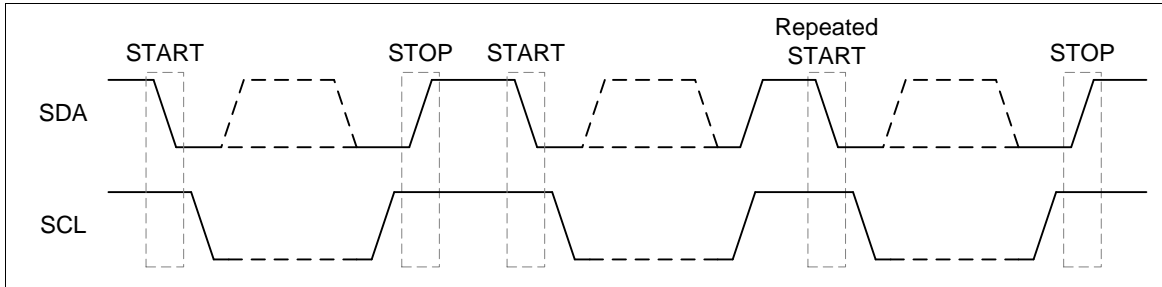

Figure 5-22 START and STOP Conditions

5.6.3.4 Slave Address Transfer

The first byte of data transferred by the master immediately after the START signal is the slave address. This is a 7-bit calling address followed by a RW bit. The RW bit signals the slave the data transfer direction. No two slaves in the system can have the same address. Only the slave with an address that matches the one transmitted by the master will respond by returning an acknowledge bit by pulling the SDA low at the 9th SCL clock cycle.

5.6.3.5 Data Transfer

Once successful slave addressing has been achieved, the data transfer can proceed on a byte-by-byte basis in the direction specified by the RW bit sent by the master. Each transferred byte is followed by an acknowledge bit on the 9th SCL clock cycle. If the slave signals a Not Acknowledge (NACK), the master can generate a STOP signal to abort the data transfer or generate a Repeated START signal and start a new transfer cycle.

If the master, as the receiving device, does Not Acknowledge (NACK) the slave, the slave releases the SDA line for the master to generate a STOP or Repeated START signal.

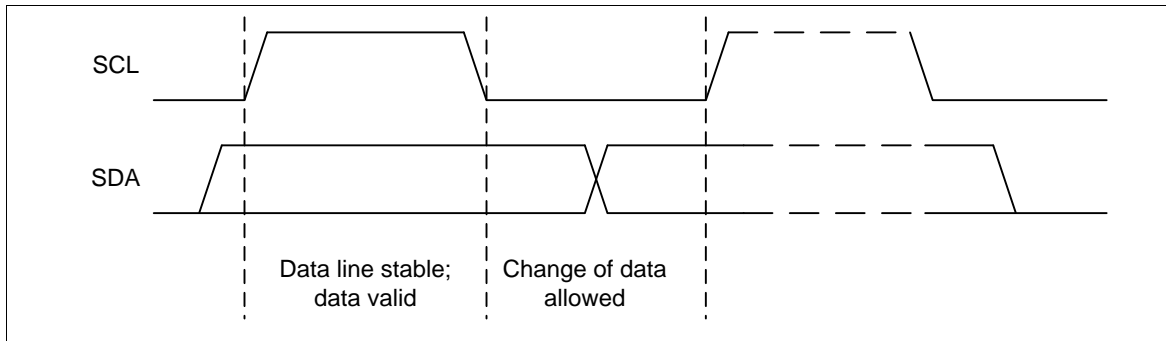

Figure 5-23 Bit Transfer on I²C Bus

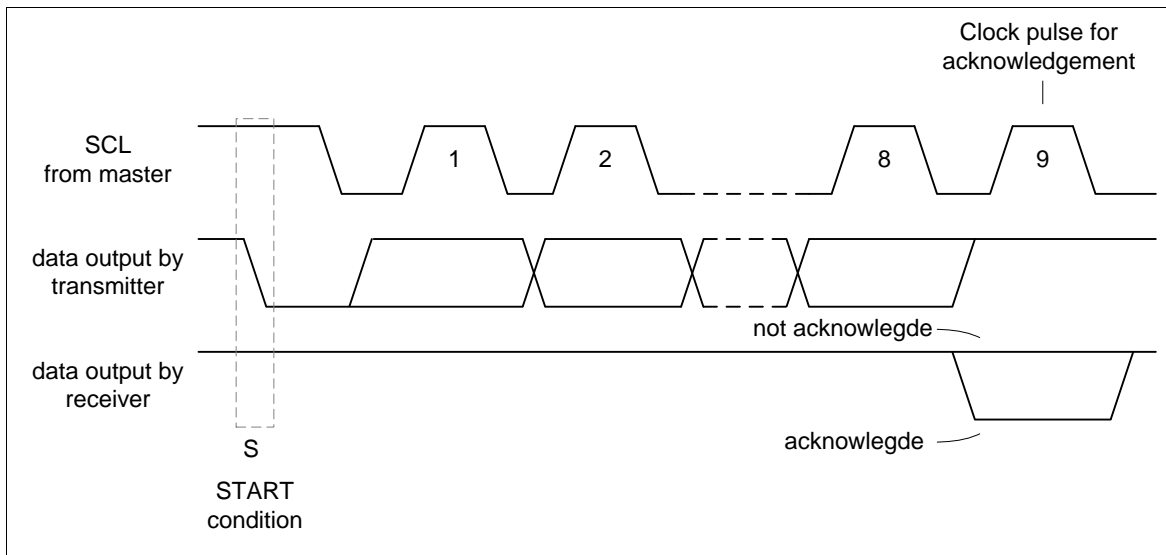

Figure 5-24 Acknowledge on I²C Bus



5.6.4 Protocol Registers

The CPU interfaces to the I²C port through the following thirteen special function registers: I2CON (control register), I2CSTATUS (status register), I2CDAT (data register), I2CADDRn (address registers, n=0~3), I2CADMn (address mask registers, n=0~3), I2CLK (clock rate register) and I2CTOC (Time-out counter register). All bit 31~ bit 8 of these I²C special function registers are reserved. These bits do not have any functions and are all zero if read back.

When I²C port is enabled by setting ENS1 (I2CON [6]) to high, the internal states will be controlled by I2CON and I²C logic hardware. Once a new status code is generated and stored in I2CSTATUS, the I²C Interrupt Flag bit SI (I2CON [3]) will be set automatically. If the Enable Interrupt bit EI (I2CON [7]) is set high at this time, the I²C interrupt will be generated. The bit field I2CSTATUS[7:3] stores the internal state code, the lowest 3 bits of I2CSTATUS are always zero and the content keeps stable until SI is cleared by software. The base address is 4002_0000 and 4012_0000.

5.6.4.1 Address Registers (I2CADDR)

I²C port is equipped with four slave address registers I2CADDRn (n=0~3). The contents of the register are irrelevant when I²C is in Master mode. In the Slave mode, the bit field I2CADDRn[7:1] must be loaded with the chip's own slave address. The I²C hardware will react if the contents of I2CADDRn are matched with the received slave address.

The I²C ports support the "General Call" function. If the GC bit (I2CADDRn [0]) is set the I²C port hardware will respond to General Call address (00H). Clear GC bit to disable general call function.

When GC bit is set and the I²C is in Slave mode, it can receive the general call address by 00H after Master send general call address to I²C bus, then it will follow status of GC mode.

I²C bus controllers support multiple address recognition with four address mask registers I2CADMn (n=0~3). When the bit in the address mask register is set to one, it means the received corresponding address bit is don't-care. If the bit is set to 0, that means the received corresponding register bit should be exact the same as address register.

5.6.4.2 Data Register (I2CDAT)

This register contains a byte of serial data to be transmitted or a byte which just has been received. The CPU can read from or write to this 8-bit (I2CDAT [7:0]) directly while it is not in the process of shifting a byte. when I²C is in a defined state and the serial interrupt flag (SI) is set. Data in I2CDAT [7:0] remains stable as long as SI bit is set. While data is being shifted out, data on the bus is simultaneously being shifted in; I2CDAT [7:0] always contains the last data byte present on the bus. Thus, in the event of arbitration lost, the transition from master transmitter to slave receiver is made with the correct data in I2CDAT [7:0].

I2CDAT [7:0] and the acknowledge bit form a 9-bit shift register, the acknowledge bit is controlled by the I²C hardware and cannot be accessed by the CPU. Serial data is shifted through the acknowledge bit into I2CDAT [7:0] on the rising edges of serial clock pulses on the SCL line. When a byte has been shifted into I2CDAT [7:0], the serial data is available in I2CDAT [7:0], and the acknowledge bit (ACK or NACK) is returned by the control logic during the ninth clock pulse. Serial data is shifted out from I2CDAT [7:0] on the falling edges of SCL clock pulses, and is shifted into I2CDAT [7:0] on the rising edges of SCL clock pulses.

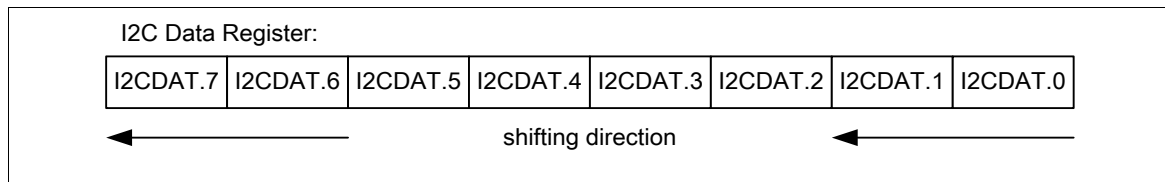

Figure 5-25 I²C Data Shifting Direction

5.6.4.3 Control Register (I2CON)

The CPU can read from and write to this 8-bit field of I2CON [7:0] directly. Two bits are affected by hardware: the SI bit is set when the I²C hardware requests a serial interrupt, and the STO bit is cleared when a STOP condition is present on the bus. The STO bit is also cleared when ENS1 = 0.

- EI Enable Interrupt.
- ENS1 Set to enable I²C serial function controller. When ENS1=1 the I²C serial function enables. The Multi Function pin function of SDA and SCL must be set to I²C function.
- STA I²C START Control Bit. Setting STA to logic 1 to enter Master mode, the I²C hardware sends a START or repeat START condition to bus when the bus is free.
- STO I²C STOP Control Bit. In Master mode, setting STO to transmit a STOP condition to bus then I²C hardware will check the bus condition if a STOP condition is detected this flag will be cleared by hardware automatically. In a Slave mode, setting STO resets I²C hardware to the defined “not addressed” Slave mode. This means it is NO LONGER in the slave receiver mode to receive data from the master transmit device.
- SI I²C Interrupt Flag. When a new I²C state is present in the I2CSTATUS register, the SI flag is set by hardware, and if bit EI (I2CON [7]) is set, the I²C interrupt is requested. SI must be cleared by software. Clear SI is by writing 1 to this bit. All states are listed in section 5.6.6
- AA Assert Acknowledge Control Bit. When AA=1 prior to address or data received, an acknowledged (low level to SDA) will be returned during the acknowledge clock pulse on the SCL line when 1.) A slave is acknowledging the address sent from master, 2.) The receiver devices are acknowledging the data sent by transmitter. When AA=0 prior to address or data received, a Not acknowledged (high level to SDA) will be returned during the acknowledge clock pulse on the SCL line.



5.6.4.4 Status Register (I2CSTATUS)

I2CSTATUS [7:0] is an 8-bit read-only register. The three least significant bits are always 0. The bit field I2CSTATUS [7:3] contain the status code. There are 26 possible status codes, All states are listed in section 5.6.6. When I2CSTATUS [7:0] contains F8H, no serial interrupt is requested. All other I2CSTATUS [7:3] values correspond to defined I²C states. When each of these states is entered, a status interrupt is requested (SI = 1). A valid status code is present in I2CSTATUS[7:3] one cycle after SI is set by hardware and is still present one cycle after SI has been reset by software.

In addition, state 00H stands for a Bus Error. A Bus Error occurs when a START or STOP condition is present at an illegal position in the format frame. Examples of illegal positions are during the serial transfer of an address byte, a data byte or an acknowledge bit. To recover I²C from bus error, STO should be set and SI should be clear to enter not addressed Slave mode. Then clear STO to release bus and to wait new communication. I²C bus can not recognize stop condition during this action when bus error occurs.

Master Mode		Slave Mode	
STATUS	Description	STATUS	Description
0x08	Start	0xA0	Slave Transmit Repeat Start or Stop
0x10	Master Repeat Start	0xA8	Slave Transmit Address ACK
0x18	Master Transmit Address ACK	0xB0	Slave Transmit Arbitration Lost
0x20	Master Transmit Address NACK	0xB8	Slave Transmit Data ACK
0x28	Master Transmit Data ACK	0xC0	Slave Transmit Data NACK
0x30	Master Transmit Data NACK	0xC8	Slave Transmit Last Data ACK
0x38	Master Arbitration Lost	0x60	Slave Receive Address ACK
0x40	Master Receive ACK	0x68	Slave Receive Arbitration Lost
0x48	Master Receive NACK	0x80	Slave Receive Data ACK
0x50	Master Receive ACK	0x88	Slave Receive Data NACK
0x58	Master Receive NACK	0x70	GC mode Address ACK
0x00	Bus error	0x78	GC mode Arbitration Lost
		0x90	GC mode Data ACK
		0x98	GC mode Data NACK
0xF8	Bus Released Note: Status "0xF8" exists in both master/Slave modes, and it won't raise interrupt.		

Table 5-6 I²C Status Code Description Table



5.6.4.5 I²C Clock Baud Rate Bits (I2CLK)

The data baud rate of I²C is determined by I2CLK [7:0] register when I²C is in a Master mode. It is not important when I²C is in a Slave mode. In the Slave modes, I²C will automatically synchronize with any clock frequency from master I²C device.

The data baud rate of I²C setting is Data Baud Rate of I²C = (system clock) / (4x (I2CLK [7:0] +1)). If system clock = 16 MHz, the I2CLK [7:0] = 40 (28H), so data baud rate of I²C = 16 MHz / (4x (40 +1)) = 97.5 Kbits/sec.

5.6.4.6 The I²C Time-out Counter Register (I2CTOC)

There is a 14-bit time-out counter which can be used to deal with the I²C bus hang-up. If the time-out counter is enabled, the counter starts up counting until it overflows (TIF=1) and generates I²C interrupt to CPU or stops counting by clearing ENTI to 0. When time-out counter is enabled, setting flag SI to high will reset counter and re-start up counting after SI is cleared. If I²C bus hangs up, it causes the I2CSTATUS and flag SI are not updated for a period, the 14-bit time-out counter may overflow and acknowledge CPU the I²C interrupt. Refer to the Figure 5-26 for the 14-bit time-out counter. User may write 1 to clear TIF to 0.

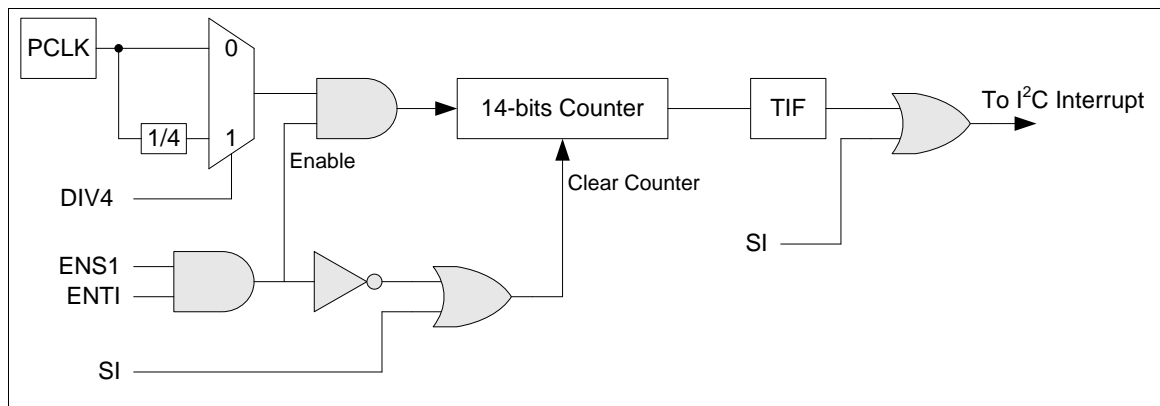

Figure 5-26: I²C Time-out Count Block Diagram



5.6.5 Register Map

R: read only, W: write only, R/W: both read and write

Register	Offset	R/W	Description	Reset Value
I2C Base Address:				
$I2Cn_BA = 0x4002_0000 + (0x0010_0000 * n)$				
n = 0,1				
I2CON	I2Cn_BA+0x00	R/W	I ² C Control Register	0x0000_0000
I2CADDR0	I2Cn_BA+0x04	R/W	I ² C Slave Address Register0	0x0000_0000
I2CDAT	I2Cn_BA+0x08	R/W	I ² C Data Register	0x0000_0000
I2CSTATUS	I2Cn_BA+0x0C	R	I ² C Status Register	0x0000_00F8
I2CLK	I2Cn_BA+0x10	R/W	I ² C Clock Divided Register	0x0000_0000
I2CTOC	I2Cn_BA+0x14	R/W	I ² C Time-Out Counter Register	0x0000_0000
I2CADDR1	I2Cn_BA+0x18	R/W	I ² C Slave Address Register1	0x0000_0000
I2CADDR2	I2Cn_BA+0x1C	R/W	I ² C Slave Address Register2	0x0000_0000
I2CADDR3	I2Cn_BA+0x20	R/W	I ² C Slave Address Register3	0x0000_0000
I2CADM0	I2Cn_BA+0x24	R/W	I ² C Slave Address Mask Register0	0x0000_0000
I2CADM1	I2Cn_BA+0x28	R/W	I ² C Slave Address Mask Register1	0x0000_0000
I2CADM2	I2Cn_BA+0x2C	R/W	I ² C Slave Address Mask Register2	0x0000_0000
I2CADM3	I2Cn_BA+0x30	R/W	I ² C Slave Address Mask Register3	0x0000_0000



5.6.6 Register Description

I²C Control Register (I2CON)

Register	Offset	R/W	Description	Reset Value
I2CON	I2Ch_BA+0x00	R/W	I ² C Control Register	0x0000_0000

31	30	29	28	27	26	25	24
Reserved							
23	22	21	20	19	18	17	16
Reserved							
15	14	13	12	11	10	9	8
Reserved							
7	6	5	4	3	2	1	0
EI	ENS1	STA	STO	SI	AA	Reserved	

Bits	Description	
[31:8]	Reserved	Reserved
[7]	EI	Interrupt Enable 1 = I ² C interrupt Enabled 0 = I ² C interrupt Disabled
[6]	ENS1	I²C Controller Enable Bit 1 = Enabled 0 = Disabled Set to enable I ² C serial function controller. When ENS1 = 1 the I ² C serial function is enabled. The multi-function pin function of SDA and SCL must set to I ² C function first.
[5]	STA	I²C START Control Bit Setting STA to logic 1 to enter Master mode, the I ² C hardware sends a START or repeat START condition to bus when the bus is free.
[4]	STO	I²C STOP Control Bit In Master mode, setting STO to transmit a STOP condition to bus then I ² C hardware will check the bus condition if a STOP condition is detected this bit will be cleared by hardware automatically. In a Slave mode, setting STO resets I ² C hardware to the defined "not addressed" Slave mode. This means it is NO LONGER in the slave receiver mode to receive data from the master transmit device.
[3]	SI	I²C Interrupt Flag When a new I ² C state is present in the I2CSTATUS register, the SI flag is set by hardware, and if bit EI (I2CON [7]) is set, the I ² C interrupt is requested. SI must be cleared by software. Clear SI is by writing 1 to this bit.
[2]	AA	Assert Acknowledge Control Bit When AA=1 prior to address or data received, an acknowledged (low level to SDA) will



		be returned during the acknowledge clock pulse on the SCL line when 1.) A slave is acknowledging the address sent from master, 2.) The receiver devices are acknowledging the data sent by transmitter. When AA=0 prior to address or data received, a Not acknowledged (high level to SDA) will be returned during the acknowledge clock pulse on the SCL line.
[1:0]	Reserved	Reserved



I²C Data Register (I2CDAT)

Register	Offset	R/W	Description	Reset Value
I2CDAT	I2Cn_BA+0x08	R/W	I ² C Data Register	0x0000_0000

31	30	29	28	27	26	25	24
Reserved							
23	22	21	20	19	18	17	16
Reserved							
15	14	13	12	11	10	9	8
Reserved							
7	6	5	4	3	2	1	0
I2CDAT[7:0]							

Bits	Description
[31:8]	Reserved
[7:0]	<p>I²C Data Register</p> <p>Bit [7:0] is located with the 8-bit transferred data of I²C serial port.</p>



I²C Status Register (I2CSTATUS)

Register	Offset	R/W	Description	Reset Value
I2CSTATUS	I2Cn_BA+0x0C	R	I ² C Status Register	0x0000_00F8

31	30	29	28	27	26	25	24
Reserved							
23	22	21	20	19	18	17	16
Reserved							
15	14	13	12	11	10	9	8
Reserved							
7	6	5	4	3	2	1	0
I2CSTATUS[7:3]					0	0	0

Bits	Description	
[31:8]	Reserved	Reserved
[7:0]	I2CSTATUS	<p>I²C Status Register</p> <p>The status register of I²C:</p> <p>The three least significant bits are always 0. The five most significant bits contain the status code. There are 26 possible status codes. When I2CSTATUS contains F8H, no serial interrupt is requested. All other I2CSTATUS values correspond to defined I²C states. When each of these states is entered, a status interrupt is requested (SI = 1). A valid status code is present in I2CSTATUS one cycle after SI is set by hardware and is still present one cycle after SI has been reset by software. In addition, states 00H stands for a Bus Error. A Bus Error occurs when a START or STOP condition is present at an illegal position in the formation frame. Example of illegal position are during the serial transfer of an address byte, a data byte or an acknowledge bit.</p>



I²C Clock Divided Register (I2CLK)

Register	Offset	R/W	Description	Reset Value
I2CLK	I2Cn_BA+0x10	R/W	I ² C Clock Divided Register	0x0000_0000

31	30	29	28	27	26	25	24
Reserved							
23	22	21	20	19	18	17	16
Reserved							
15	14	13	12	11	10	9	8
Reserved							
7	6	5	4	3	2	1	0
I2CLK[7:0]							

Bits	Description
[31:8]	Reserved
[7:0]	<p>I²C clock divided Register</p> <p>The I²C clock rate bits: Data Baud Rate of I²C = (system clock) / (4x (I2CLK+1)).</p> <p>Note: The minimum value of I2CLK is 4.</p>



I²C Time-Out Counter Register (I2CTOC)

Register	Offset	R/W	Description	Reset Value
I2CTOC	I2Cn_BA+0x14	R/W	I ² C Time-Out Counter Register	0x0000_0000

31	30	29	28	27	26	25	24
Reserved							
23	22	21	20	19	18	17	16
Reserved							
15	14	13	12	11	10	9	8
Reserved							
7	6	5	4	3	2	1	0
Reserved					ENTI	DIV4	TIF

Bits	Description	
[31:3]	Reserved	Reserved
[2]	ENTI	<p>Time-out Counter Enable/Disable</p> <p>1 = Enabled 0 = Disabled</p> <p>When Enabled, the 14-bit time-out counter will start counting when SI is clear. Setting flag SI to high will reset counter and re-start up counting after SI is cleared.</p>
[1]	DIV4	<p>Time-Out counter input clock is divided by 4</p> <p>1 = Enabled 0 = Disabled</p> <p>When Enabled, The time-out period is extend 4 times.</p>
[0]	TIF	<p>Time-Out Flag</p> <p>This bit is set by H/W when I²C time-out happened and it can interrupt CPU if I²C interrupt enable bit (EI) is set to 1.</p> <p>Software can write 1 to clear this bit.</p>



I²C Slave Address Register (I2CADDRx)

Register	Offset	R/W	Description	Reset Value
I2CADDR0	I2Cn_BA+0x04	R/W	I ² C Slave Address Register0	0x0000_0000
I2CADDR1	I2Cn_BA+0x18	R/W	I ² C Slave Address Register1	0x0000_0000
I2CADDR2	I2Cn_BA+0x1C	R/W	I ² C Slave Address Register2	0x0000_0000
I2CADDR3	I2Cn_BA+0x20	R/W	I ² C Slave Address Register3	0x0000_0000

31	30	29	28	27	26	25	24
Reserved							
23	22	21	20	19	18	17	16
Reserved							
15	14	13	12	11	10	9	8
Reserved							
7	6	5	4	3	2	1	0
I2CADDR[7:1]							GC

Bits	Description	
[31:8]	Reserved	Reserved
[7:1]	I2CADDR	I²C Address Register The content of this register is irrelevant when I ² C is in Master mode. In the Slave mode, the seven most significant bits must be loaded with the chip's own address. The I ² C hardware will react if either of the address is matched.
[0]	GC	General Call Function 0 = General Call function Disabled. 1 = General Call function Enabled.



I²C Slave Address Mask Register (I2CADMx)

Register	Offset	R/W	Description	Reset Value
I2CADM0	I2Cn_BA+0x24	R/W	I ² C Slave Address Mask Register0	0x0000_0000
I2CADM1	I2Cn_BA+0x28	R/W	I ² C Slave Address Mask Register1	0x0000_0000
I2CADM2	I2Cn_BA+0x2C	R/W	I ² C Slave Address Mask Register2	0x0000_0000
I2CADM3	I2Cn_BA+0x30	R/W	I ² C Slave Address Mask Register3	0x0000_0000

31	30	29	28	27	26	25	24
Reserved							
23	22	21	20	19	18	17	16
Reserved							
15	14	13	12	11	10	9	8
Reserved							
7	6	5	4	3	2	1	0
I2CADM[7:1]							Reserved

Bits	Description	
[31:8]	Reserved	Reserved
[7:1]	I2CADM	<p>I²C Address Mask register</p> <p>1 = Mask enable (the received corresponding address bit is don't care.)</p> <p>0 = Mask disable (the received corresponding register bit should be exact the same as address register.)</p> <p>I²C bus controllers support multiple address recognition with four address mask register. When the bit in the address mask register is set to one, it means the received corresponding address bit is don't-care. If the bit is set to 0, that means the received corresponding register bit should be exact the same as address register.</p>
[0]	Reserved	Reserved

5.6.7 Operation Modes

The on-chip I²C ports support five operation modes, Master transmitter, Master receiver, Slave transmitter, Slave receiver, and GC call.

In a given application, I²C port may operate as a master or as a slave. In Slave mode, the I²C port hardware looks for its own slave address and the general call address. If one of these addresses is detected, and if the slave is willing to receive or transmit data from/to master (by setting the AA bit), acknowledge pulse will be transmitted out on the 9th clock, hence an interrupt is requested on both master and slave devices if interrupt is enabled. When the microcontroller wishes to become the bus master, the hardware waits until the bus is free before the Master mode is entered so that a possible slave action didn't be interrupted. If bus arbitration is lost in the Master mode, I²C port switches to the Slave mode immediately and can detect its own slave address in the same serial transfer.

Bits STA, STO and AA in I2CON register will determine the next state of the I²C hardware after SI flag is cleared. Upon completion of the new action, a new status code will be updated and the SI flag will be set. If the I²C interrupt control bit EI (I2CON [7]) is set, appropriate action or software branch of the new status code can be performed in the Interrupt service routine.

In the following description of five operation modes, detailed data flow is represented. The legend for those data flow figures is shown in Figure 5-27

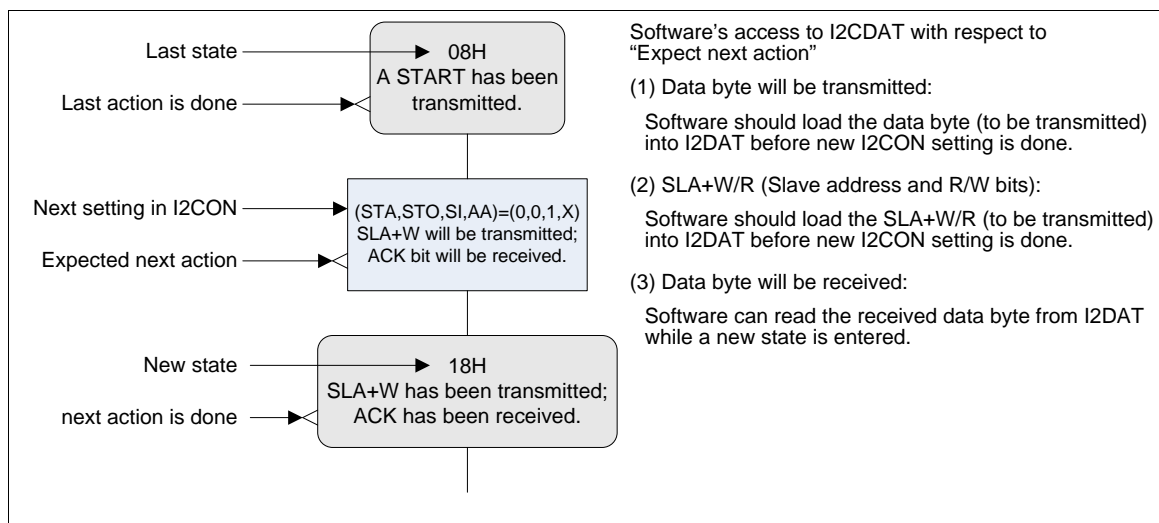

Figure 5-27 Legend for the Following Five Figures



5.6.7.1 Master Transmitter Mode

As shown in Figure 5-28, in master transmitter mode, serial data output through SDA while SCL outputs the serial clock. The first byte transmitted contains the slave address of the receiving device (7-bit) and the data direction bit. In this case the data direction bit (R/W) will be logic 0, and it is represented by “W” in the Figure 5-20. Thus the first byte transmitted is SLA+W. Serial data is transmitted 8-bit at a time. After each byte is transmitted, an acknowledge bit is received. START and STOP conditions are output to indicate the beginning and the end of a serial transfer.

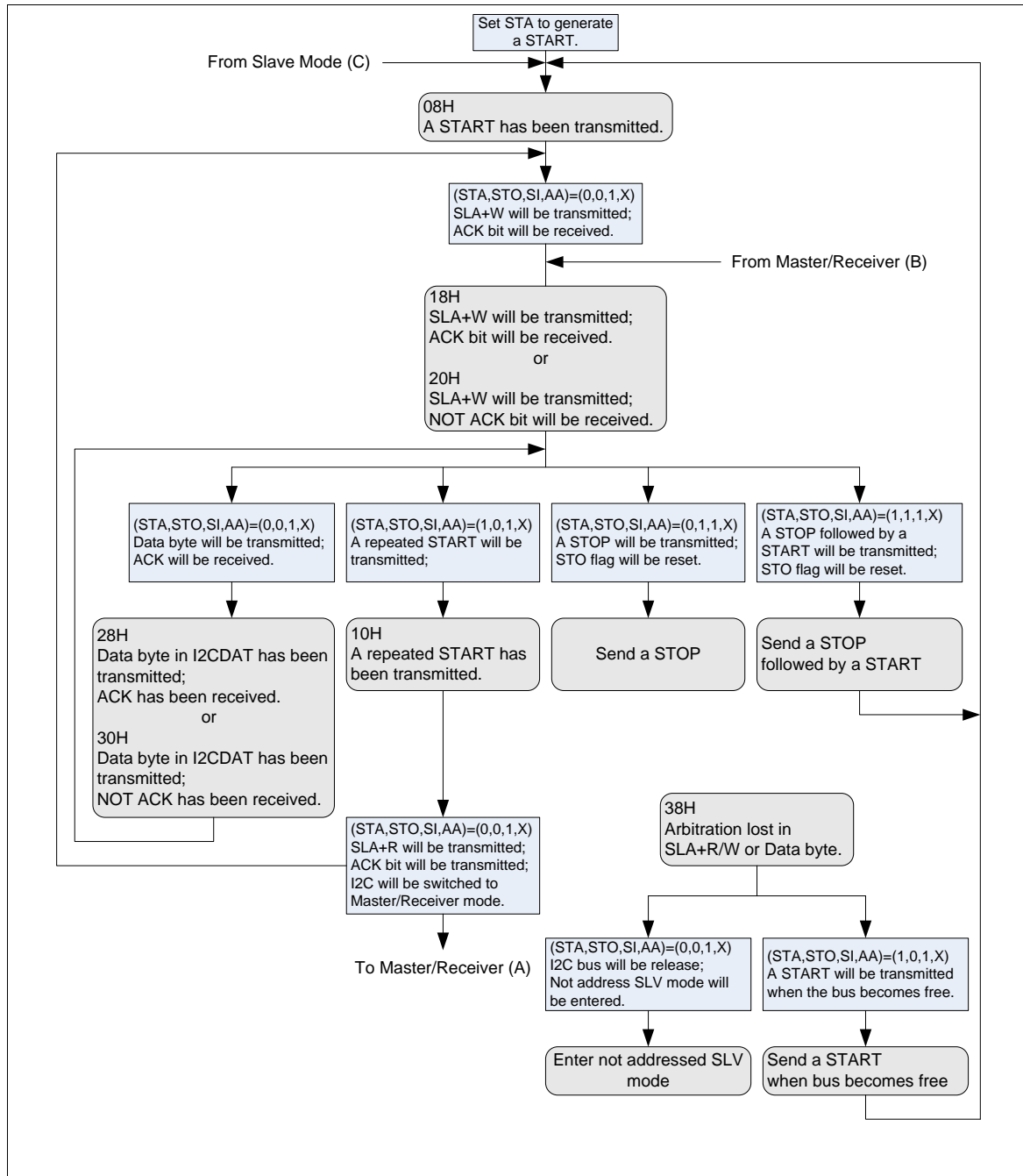

Figure 5-28 Master Transmitter Mode

5.6.7.2 Master Receiver Mode

As shown in Figure 5-29, in this case the data direction bit (R/W) will be logic 1, and it is represented by “R” in the Figure 5-21. Thus the first byte transmitted is SLA+R. Serial data is received via SDA while SCL outputs the serial clock. Serial data is received 8-bit at a time. After each byte is received, an acknowledge bit is transmitted. START and STOP conditions are output to indicate the beginning and end of a serial transfer.

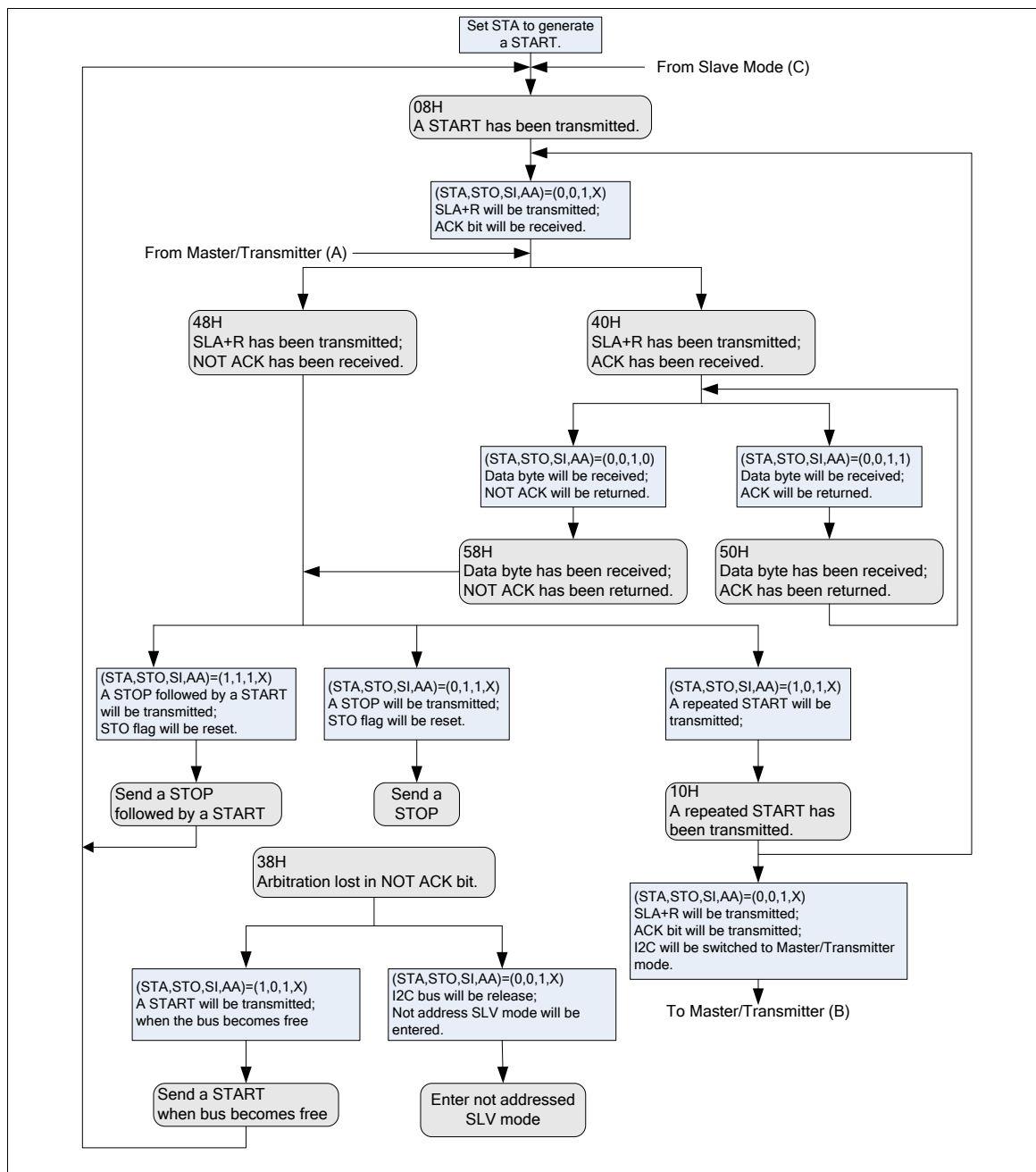

Figure 5-29 Master Receiver Mode



5.6.7.3 Slave Receiver Mode

As shown in Figure 5-30, serial data and the serial clock are received through SDA and SCL. After each byte is received, an acknowledge bit is transmitted. START and STOP conditions are recognized as the beginning and end of a serial transfer. Address recognition is performed by hardware after reception of the slave address and direction bit.

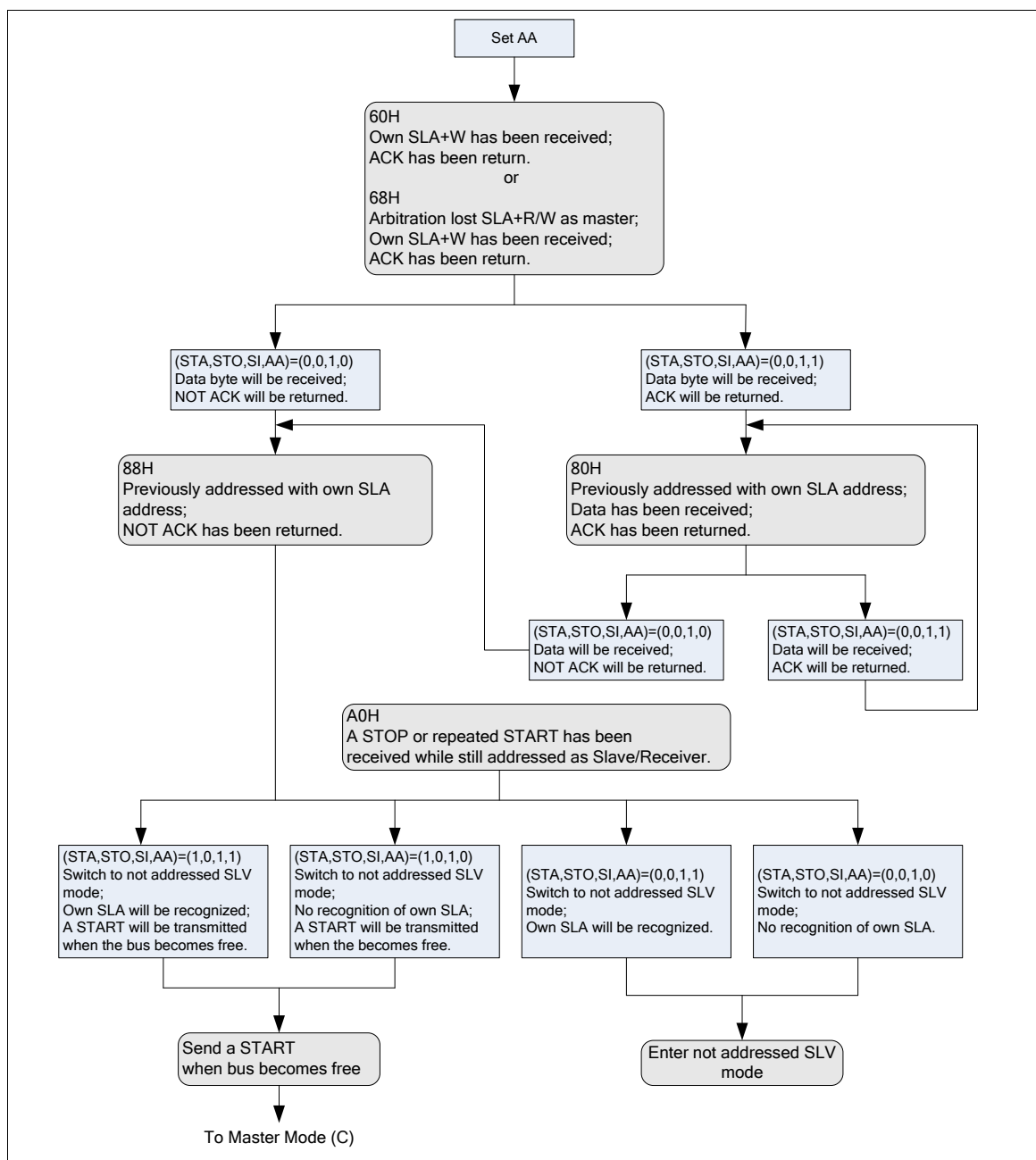

Figure 5-30 Slave Receiver Mode



5.6.7.4 Slave Transmitter Mode

As shown in Figure 5-31, the first byte is received and handled as in the slave receiver mode. However, in this mode, the direction bit will indicate that the transfer direction is reversed. Serial data is transmitted via SDA while the serial clock is input through SCL. START and STOP conditions are recognized as the beginning and end of a serial transfer.

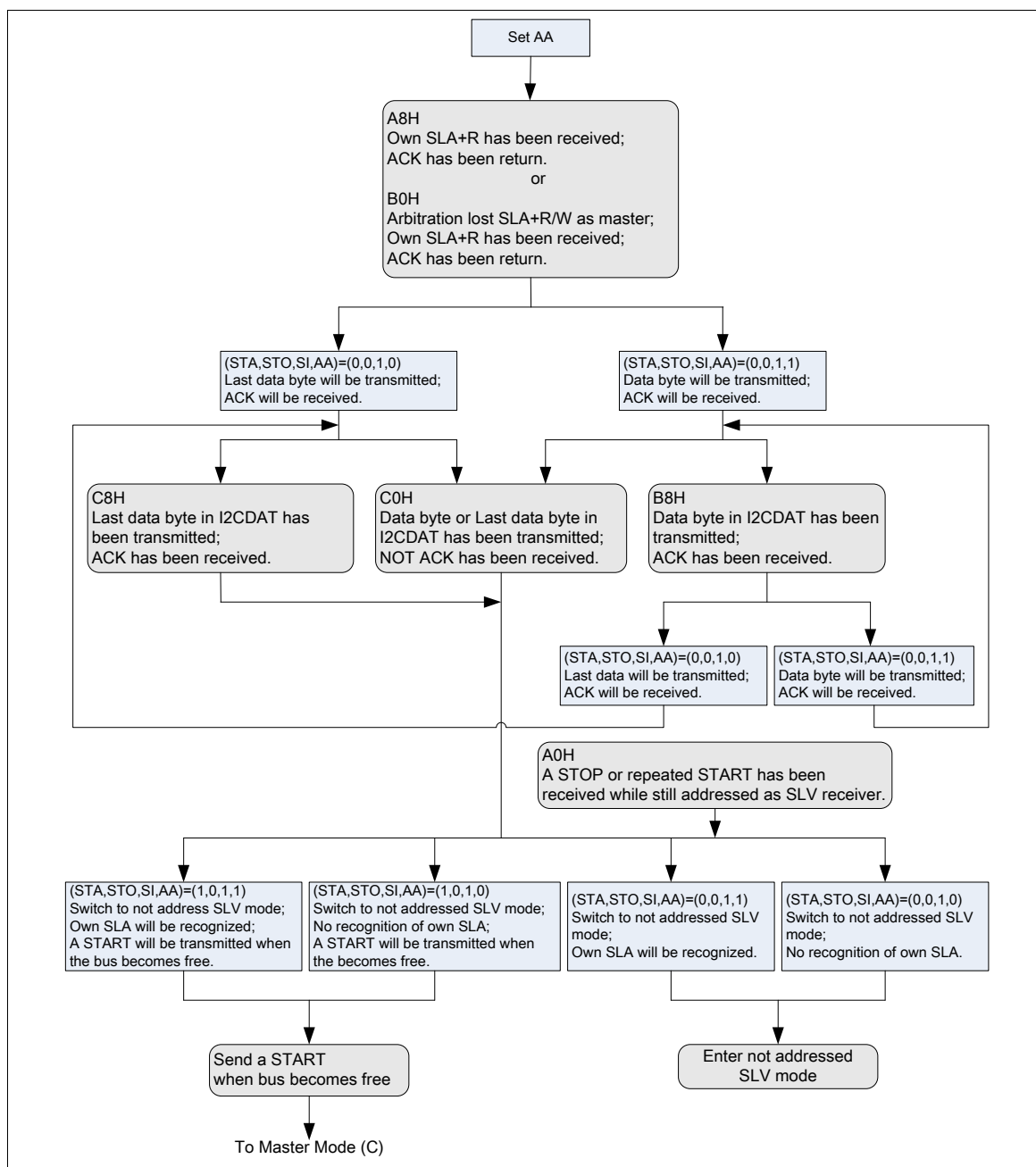

Figure 5-31 Slave Transmitter Mode



5.6.7.5 General Call (GC) Mode

As shown in Figure 5-32, if the GC bit (I2CADDRn [0]) is set, the I²C port hardware will respond to General Call address (00H). Clear GC bit to disable general call function. When GC bit is set and the I²C is in Slave mode, it can receive the general call address by 00H after Master send general call address to I²C bus, then it will follow status of GC mode. Serial data and the serial clock are received through SDA and SCL. After each byte is received, an acknowledge bit is transmitted. START and STOP conditions are recognized as the beginning and end of a serial transfer. Address recognition is performed by hardware after reception of the slave address and direction bit.

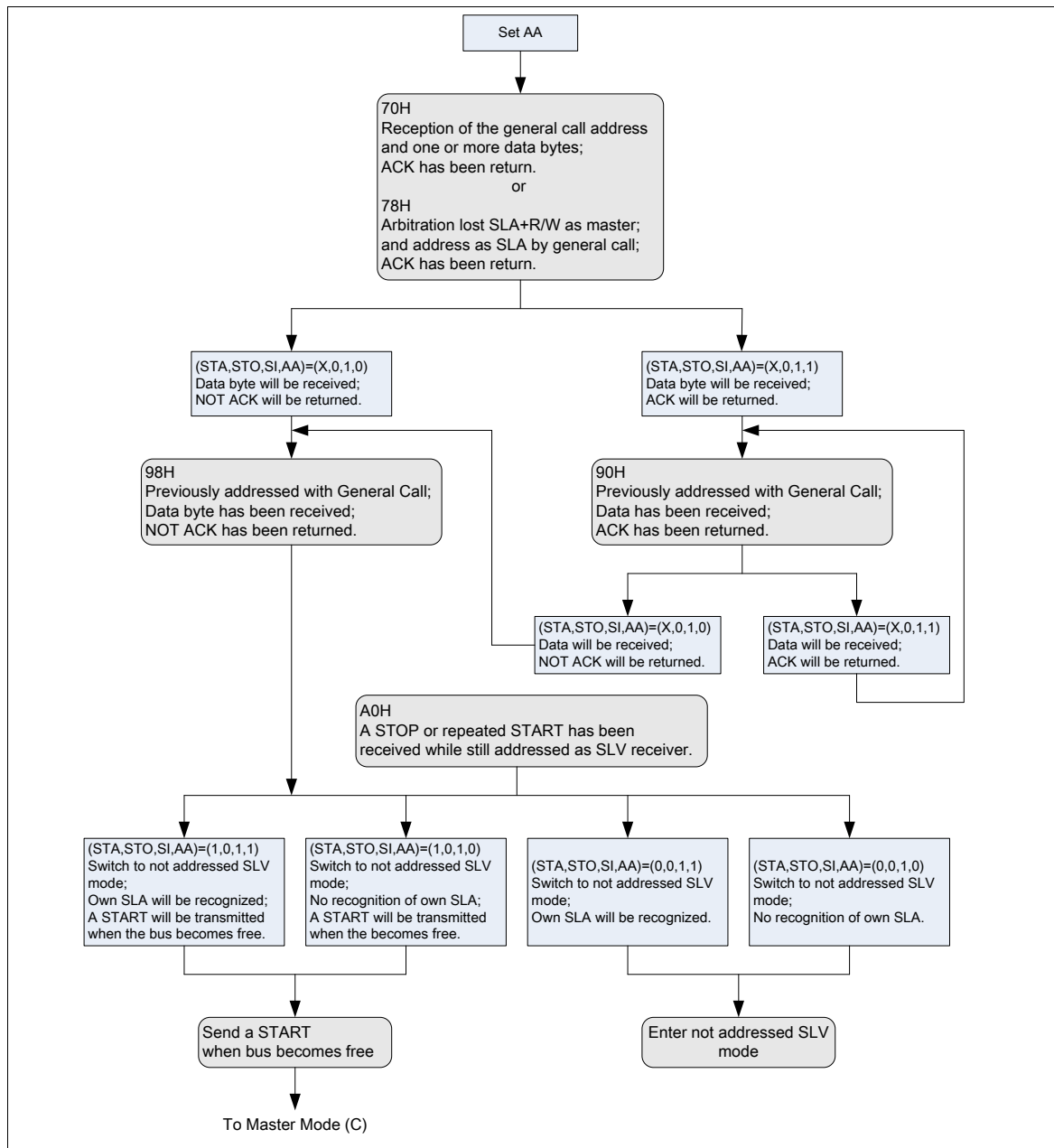

Figure 5-32 GC Mode



5.7 PWM Generator and Capture Timer (PWM)

5.7.1 Overview

The NuMicro™ NUC130/NUC140 has 2 sets of PWM group supports total 4 sets of PWM Generators which can be configured as 8 independent PWM outputs, PWM0~PWM7, or as 4 complementary PWM pairs, (PWM0, PWM1), (PWM2, PWM3), (PWM4, PWM5) and (PWM6, PWM7) with 4 programmable dead-zone generators.

Each PWM Generator has one 8-bit prescaler, one clock divider with 5 divided frequencies (1, 1/2, 1/4, 1/8, 1/16), two PWM Timers including two clock selectors, two 16-bit PWM down-counters for PWM period control, two 16-bit comparators for PWM duty control and one dead-zone generator. The 4 sets of PWM Generators provide eight independent PWM interrupt flags which are set by hardware when the corresponding PWM period down counter reaches zero. Each PWM interrupt source with its corresponding enable bit can cause CPU to request PWM interrupt. The PWM generators can be configured as one-shot mode to produce only one PWM cycle signal or auto-reload mode to output PWM waveform continuously.

When PCR.DZEN01 is set, PWM0 and PWM1 perform complementary PWM paired function; the paired PWM period, duty and dead-time are determined by PWM0 timer and Dead-zone generator 0. Similarly, the complementary PWM pairs of (PWM2, PWM3), (PWM4, PWM5) and (PWM6, PWM7) are controlled by PWM2, PWM4 and PWM6 timers and Dead-zone generator 2, 4 and 6, respectively. Refer to Figure 5-33 to Figure 5-40 for the architecture of PWM Timers.

To prevent PWM driving output pin with unsteady waveform, the 16-bit period down counter and 16-bit comparator are implemented with double buffer. When user writes data to counter/comparator buffer registers the updated value will be load into the 16-bit down counter/comparator at the time down counter reaching zero. The double buffering feature avoids glitch at PWM outputs.

When the 16-bit period down counter reaches zero, the interrupt request is generated. If PWM-timer is set as auto-reload mode, when the down counter reaches zero, it is reloaded with PWM Counter Register (CNRx) automatically then start decreasing, repeatedly. If the PWM-timer is set as one-shot mode, the down counter will stop and generate one interrupt request when it reaches zero.

The value of PWM counter comparator is used for pulse high width modulation. The counter control logic changes the output to high level when down-counter value matches the value of compare register.

The alternate feature of the PWM-timer is digital input Capture function. If Capture function is enabled the PWM output pin is switched as capture input mode. The Capture0 and PWM0 share one timer which is included in PWM0 and the Capture1 and PWM1 share PWM1 timer, and etc. Therefore user must setup the PWM-timer before enable Capture feature. After capture feature is enabled, the capture always latched PWM-counter to Capture Rising Latch Register (CRLR) when input channel has a rising transition and latched PWM-counter to Capture Falling Latch Register (CFLR) when input channel has a falling transition. Capture channel 0 interrupt is programmable by setting CCR0.CRL_IE0[1] (Rising latch Interrupt enable) and CCR0.CFL_IE0[2]] (Falling latch Interrupt enable) to decide the condition of interrupt occur. Capture channel 1 has the same feature by setting CCR0.CRL_IE1[17] and CCR0.CFL_IE1[18]. Capture channel 2 to channel 3 on each group have the same feature by setting the corresponding control bits in CCR2. For each group, whenever Capture issues Interrupt 0/1/2/3, the PWM counter 0/1/2/3 will be reload at this moment.

The maximum captured frequency that PWM can capture is confined by the capture interrupt latency. When capture interrupt occurred, software will do at least three steps, they are: Read PIIR to get interrupt source and Read CRLRx/CFLRx(x=0~3) to get capture value and finally write



1 to clear PIIR to 0. If interrupt latency will take time T_0 to finish, the capture signal mustn't transition during this interval (T_0). In this case, the maximum capture frequency will be $1/T_0$. For example:

HCLK = 50 MHz, PWM_CLK = 25 MHz, Interrupt latency is 900 ns

So the maximum capture frequency will be $1/900\text{ns} \approx 1000\text{ kHz}$

5.7.2 Features

5.7.2.1 PWM function features:

- PWM group has two PWM generators. Each PWM generator supports one 8-bit prescaler, one clock divider, two PWM-timers (down counter), one dead-zone generator and two PWM outputs.
- Up to 16-bit resolution
- PWM Interrupt request synchronized with PWM period
- One-shot or Auto-reload mode PWM
- Up to 2 PWM group (PWMA/PWMB) to support 8 PWM channels or 4 PWM paired channels

5.7.2.2 Capture Function Features:

- Timing control logic shared with PWM Generators
- Supports 8 Capture input channels shared with 8 PWM output channels
- Each channel supports one rising latch register (CRLR), one falling latch register (CFLR) and Capture interrupt flag (CAPIFx)



5.7.3 Block Diagram

The Figure 5-33 to Figure 5-40 illustrate the architecture of PWM in pair (PWM-Timer 0/1 are in one pair and PWM-Timer 2/3 are in another one, and so on.).

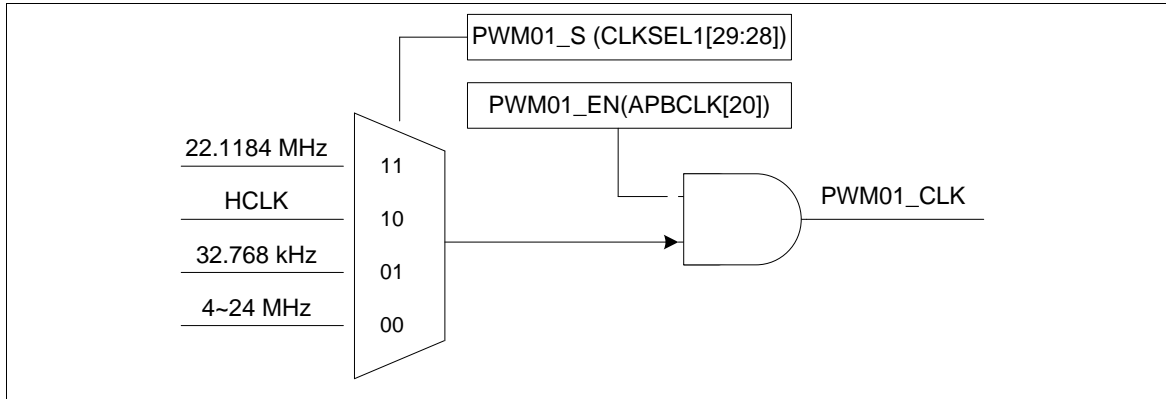

Figure 5-33 PWM Generator 0 Clock Source Control

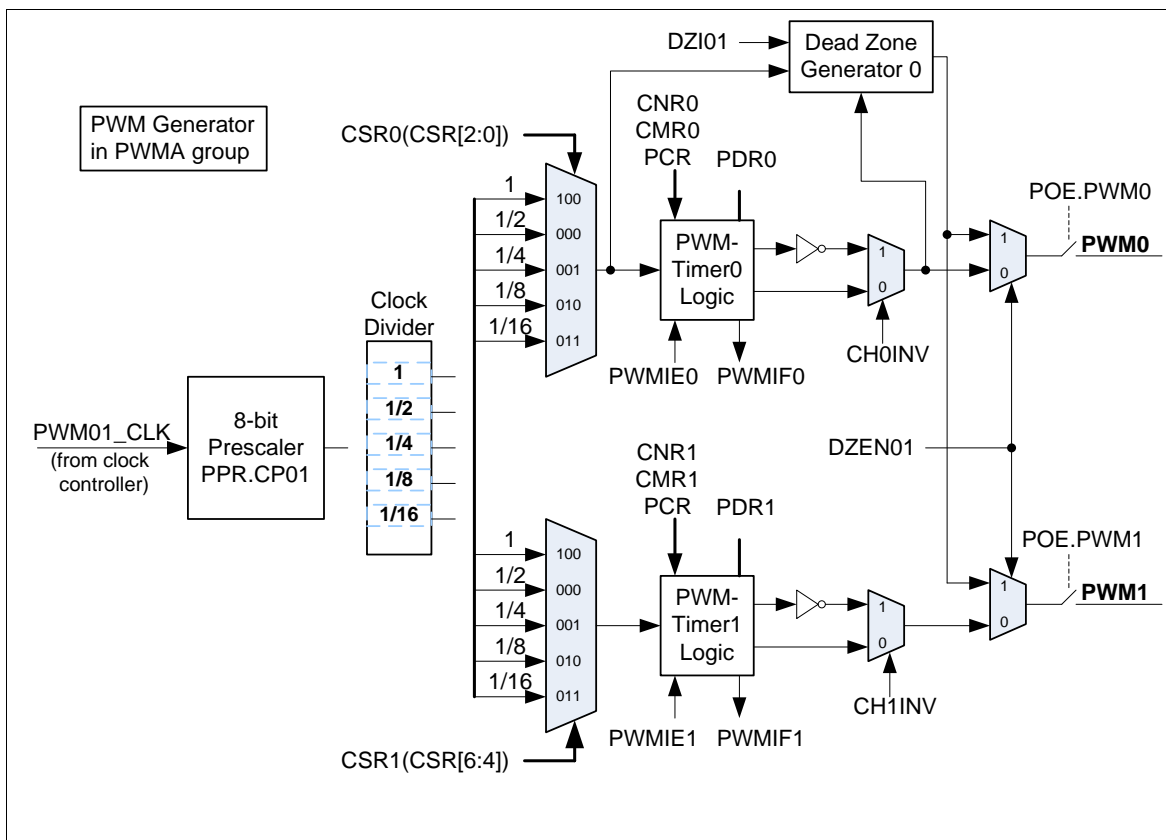

Figure 5-34 PWM Generator 0 Architecture Diagram

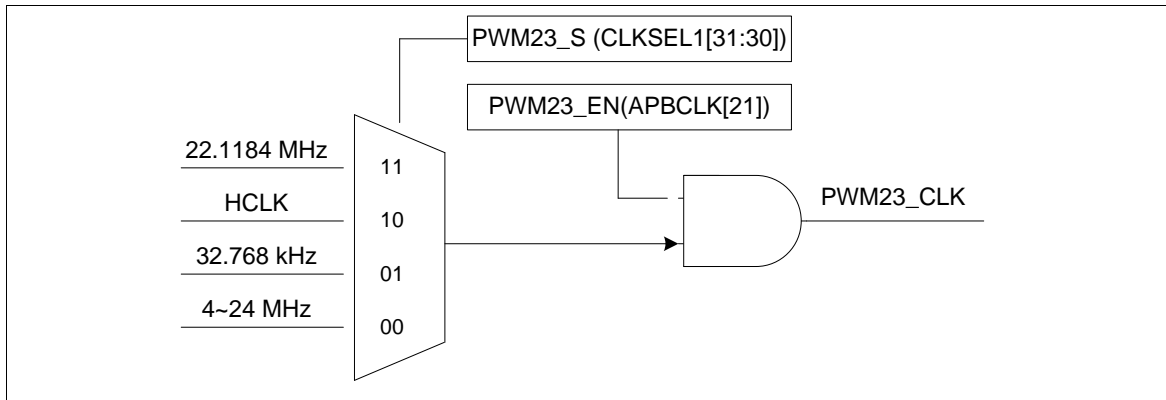

Figure 5-35 PWM Generator 2 Clock Source Control

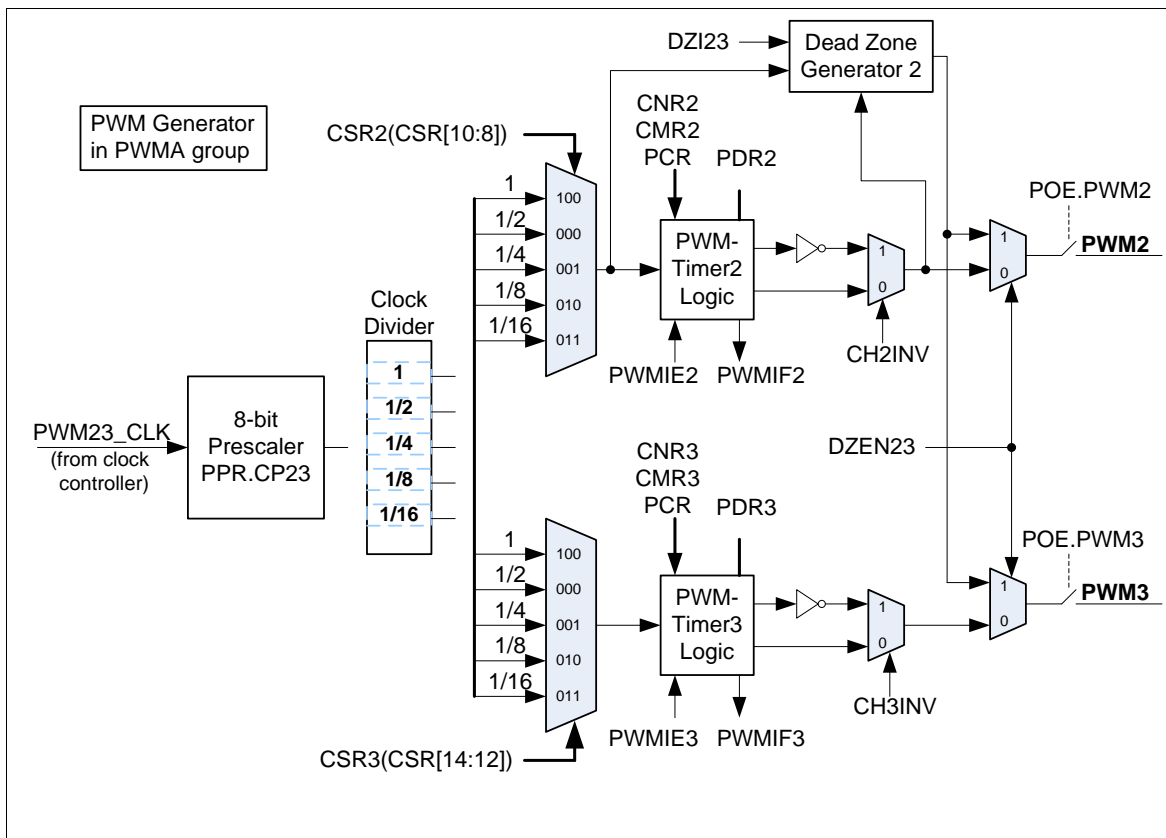

Figure 5-36 PWM Generator 2 Architecture Diagram

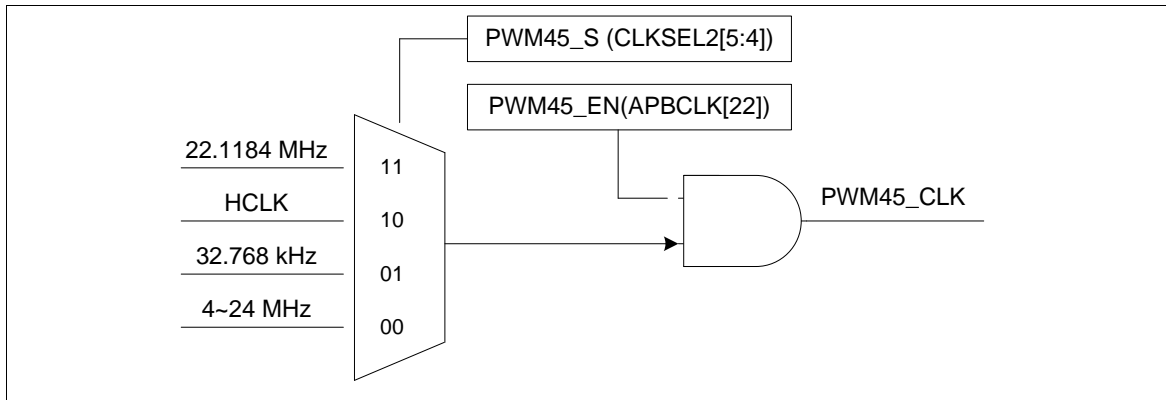

Figure 5-37 PWM Generator 4 Clock Source Control

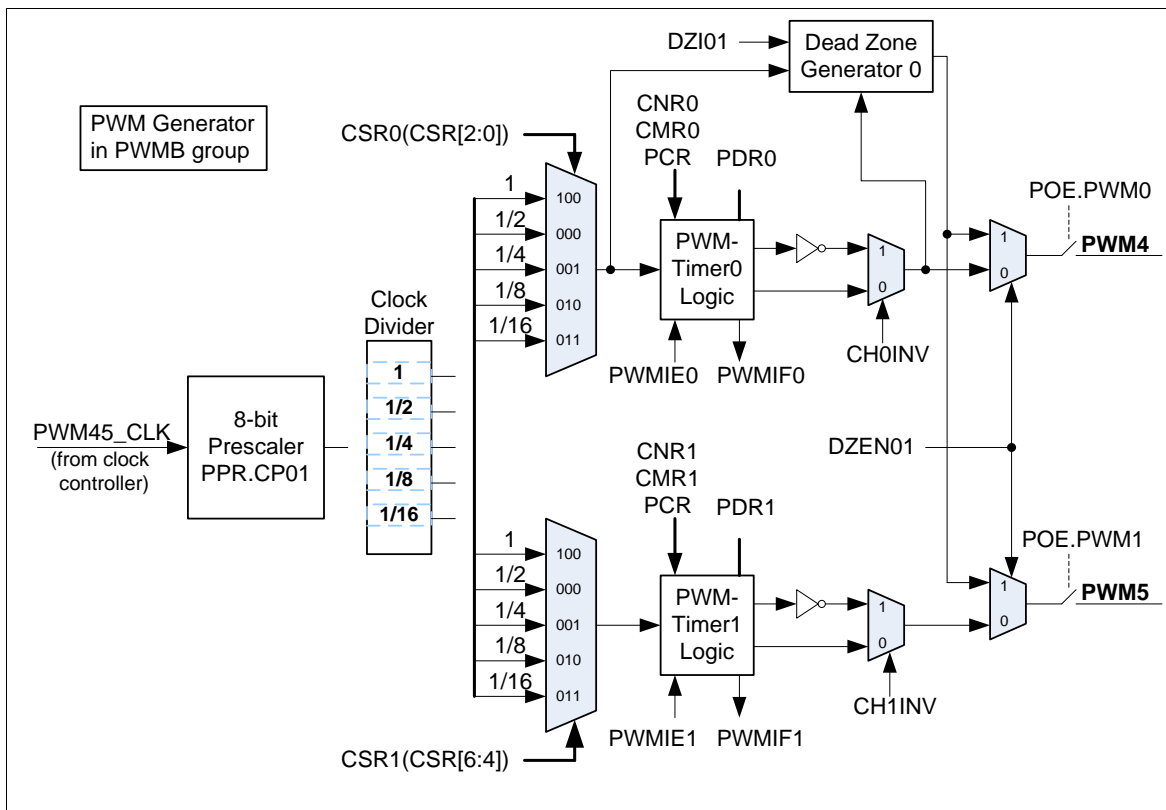

Figure 5-38 PWM Generator 4 Architecture Diagram

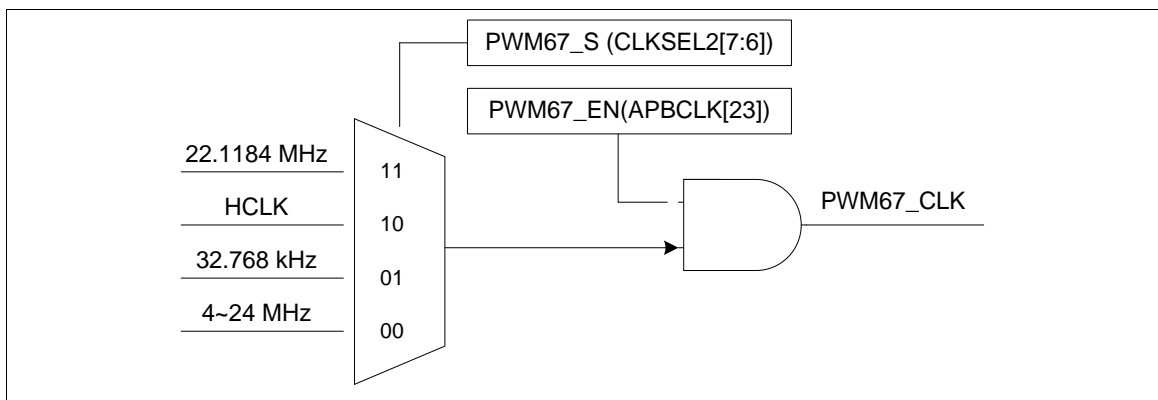

Figure 5-39 PWM Generator 6 Clock Source Control

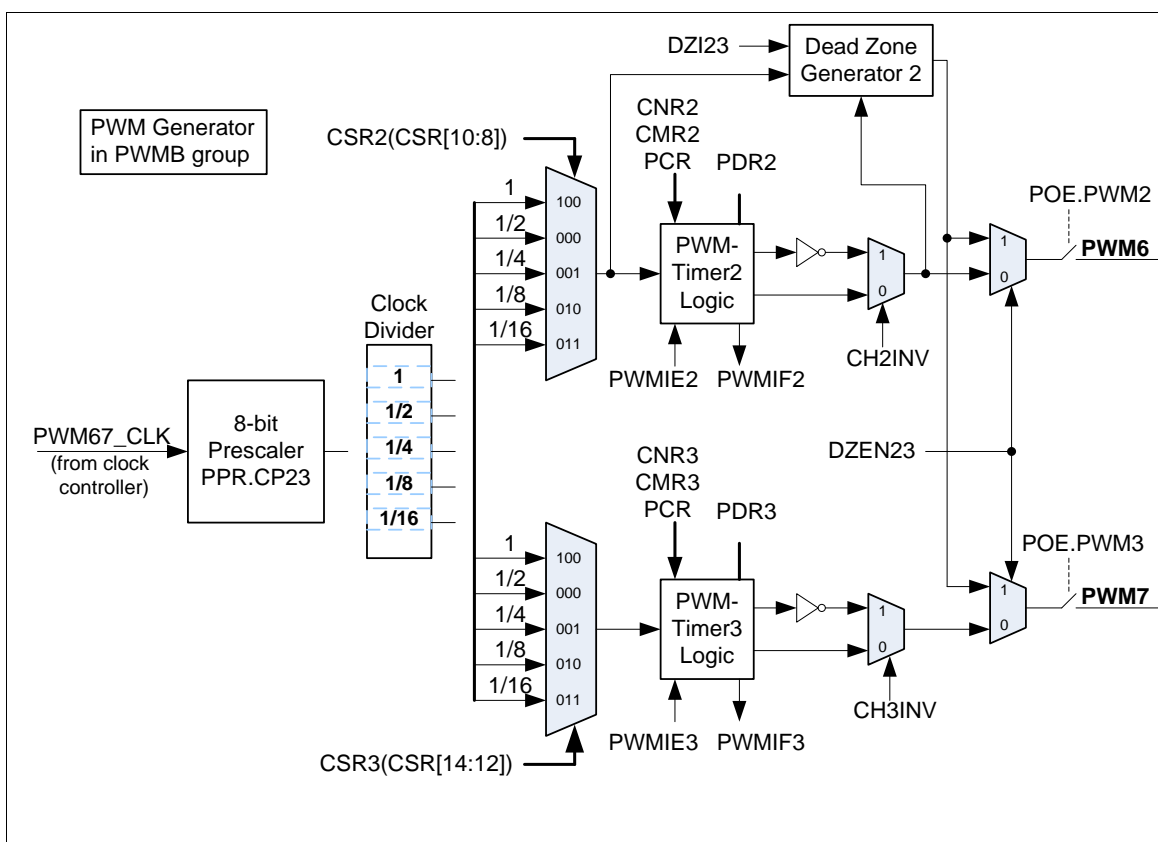

Figure 5-40 PWM Generator 6 Architecture Diagram

5.7.4 Functional Description

5.7.4.1 PWM-Timer Operation

The PWM period and duty control are configured by PWM down-counter register (CNR) and PWM comparator register (CMR). The PWM-timer timing operation is shown in Figure 5-42. The pulse width modulation follows the formula as below and the legend of PWM-Timer Comparator is shown in Figure 5-41. Note that the corresponding GPIO pins must be configured as PWM function (enable POE and disable CAPENR) for the corresponding PWM channel.

- PWM frequency = $\text{PWM}_{xy_CLK} / [(\text{prescale}+1) * (\text{clock divider}) * (\text{CNR}+1)]$; where xy, could be 01, 23, 45 or 67, depends on selected PWM channel.
- Duty ratio = $(\text{CMR}+1) / (\text{CNR}+1)$
- $\text{CMR} \geq \text{CNR}$: PWM output is always high
- $\text{CMR} < \text{CNR}$: PWM low width = $(\text{CNR}-\text{CMR})$ unit[1]; PWM high width = $(\text{CMR}+1)$ unit
- $\text{CMR} = 0$: PWM low width = (CNR) unit; PWM high width = 1 unit

Note: [1] Unit = one PWM clock cycle.

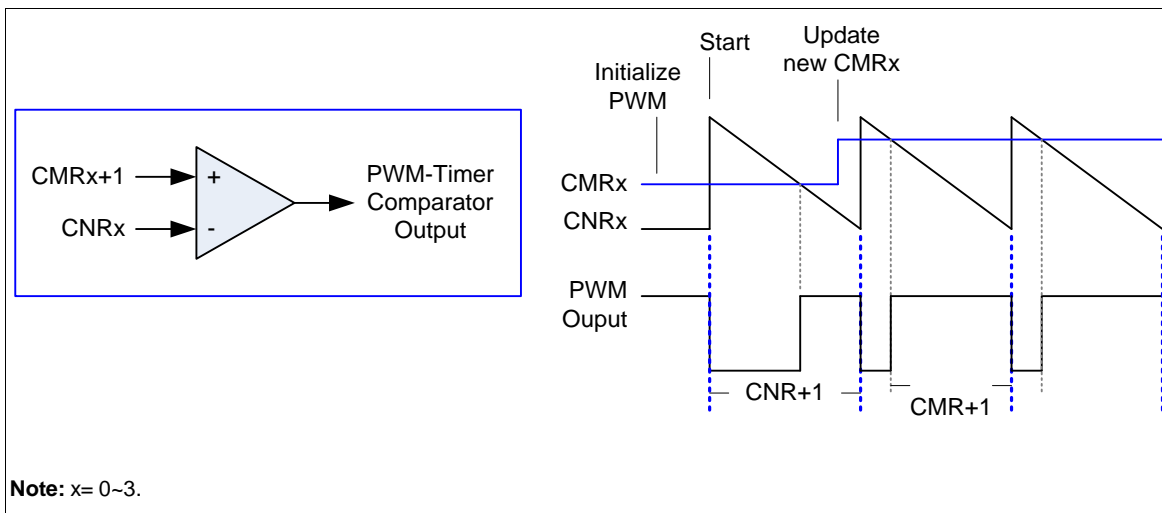

Note: x= 0~3.

Figure 5-41 Legend of Internal Comparator Output of PWM-Timer

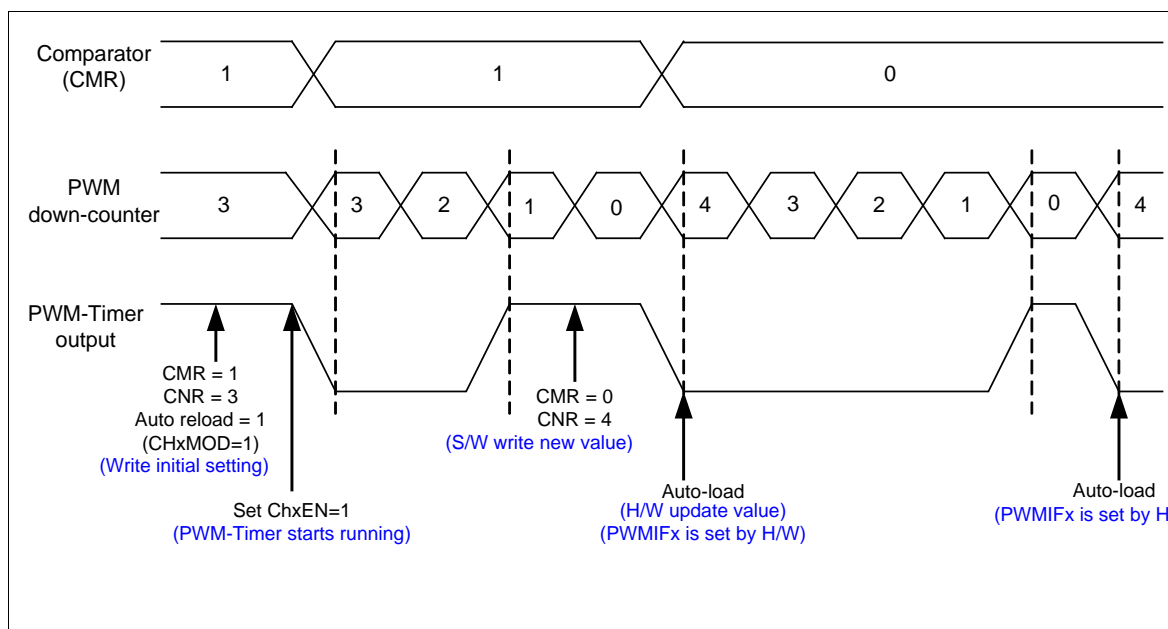

Figure 5-42 PWM-Timer Operation Timing

5.7.4.2 PWM Double Buffering, Auto-reload and One-shot Operation

PWM Timers have double buffering function the reload value is updated at the start of next period without affecting current timer operation. The PWM counter value can be written into CNRx and current PWM counter value can be read from PDRx.

PWM0 will operate in One-shot mode if CH0MOD bit is set to 0, and operate in Auto-reload mode if CH0MOD bit is set to 1. It is recommend that switch PWM0 operating mode before setting CH0EN bit as 1 to enable PWM0 counter start running because the content of CNR0 and CMR0 will be cleared to 0 to reset the PWM0 period and duty setting when PWM0 operating mode is changed. As PWM0 operate at one-shot mode, CMR0 and CNR0 should be written first and then set CH0EN bit to 1 to enable PWM0 counter to start running. After PWM0 counter down count from CNR0 value to 0, CNR0 and CMR0 will be cleared to 0 by hardware and PWM counter will be held. Software need to write new CMR0 and CNR0 value to set next one-shot period and duty. When re-start next one-shot operation, the CMR0 should be written first because PWM0 counter will auto re-start counting when CNR0 is written an non-zero value. As PWM0 operates in Auto-reload mode, CMR0 and CNR0 should be written first and then set CH0EN bit to 1 to enable PWM0 counter start running. The value of CNR0 will reload to PWM0 counter when it down count reaches zero. If CNR0 is set to 0, PWM0 counter will be held. PWM1~PWM7 performs the same function as PWM0.

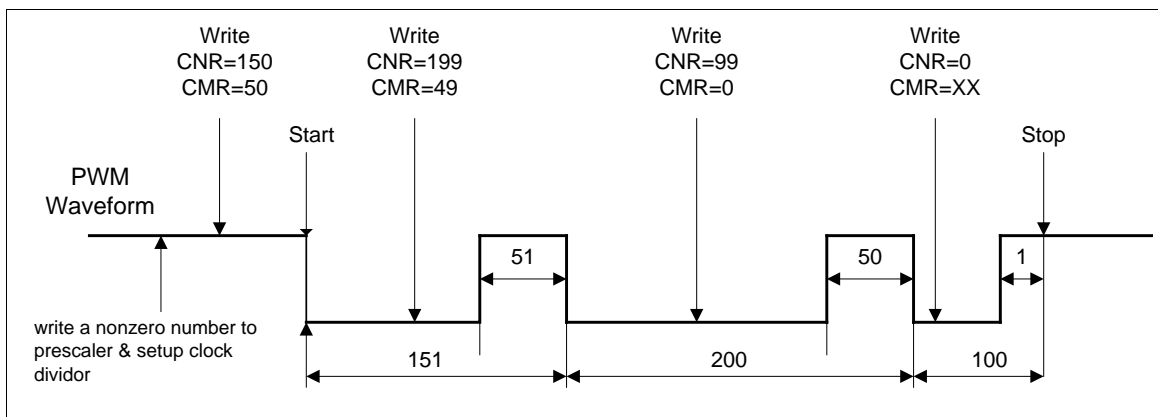

Figure 5-43 PWM Double Buffering Illustration

5.7.4.3 Modulate Duty Ratio

The double buffering function allows CMRx written at any point in current cycle. The loaded value will take effect from next cycle.

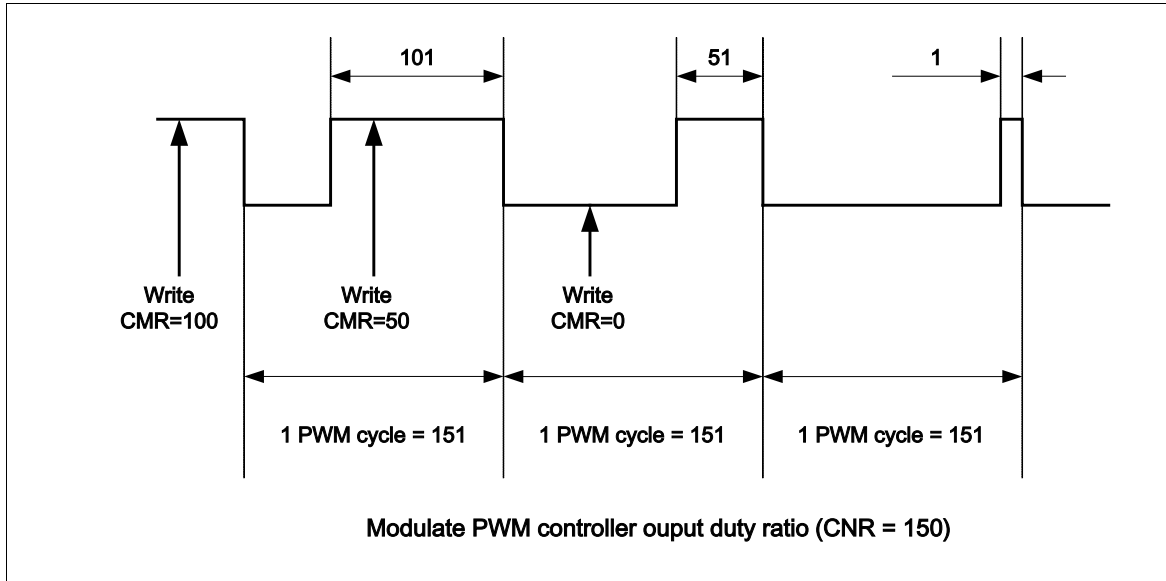

Figure 5-44 PWM Controller Output Duty Ratio

5.7.4.4 Dead-Zone Generator

PWM controller is implemented with Dead Zone generator. They are built for power device protection. This function generates a programmable time gap to delay PWM rising output. User can program PPRx.DZI to determine the Dead Zone interval.

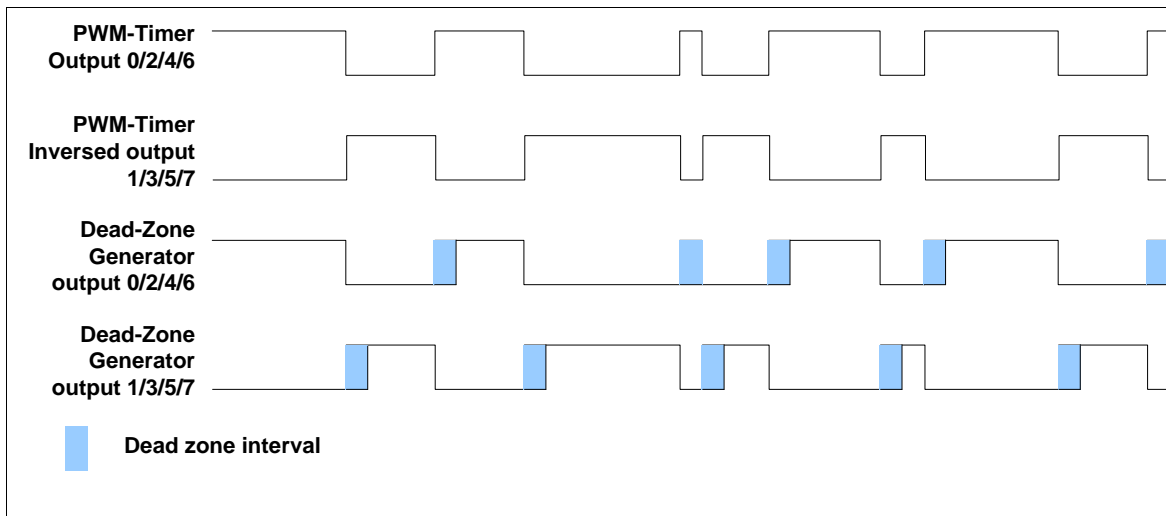

Figure 5-45 Paired-PWM Output with Dead Zone Generation Operation

5.7.4.5 Capture Operation

The Capture 0 and PWM 0 share one timer that included in PWM 0; and the Capture 1 and PWM 1 share another timer, and etc. The capture always latches PWM-counter to CRLRx when input channel has a rising transition and latches PWM-counter to CFLRx when input channel has a falling transition. Capture channel 0 interrupt is programmable by setting CCR0[1] (Rising latch Interrupt enable) and CCR0[2] (Falling latch Interrupt enable) to decide the condition of interrupt occur. Capture channel 1 has the same feature by setting CCR0[17] and CCR0[18], and etc. Whenever the Capture controller issues a capture interrupt, the corresponding PWM counter will be reloaded with CNRx at this moment. Note that the corresponding GPIO pins must be configured as capture function (disable POE and enable CAPENR) for the corresponding capture channel.

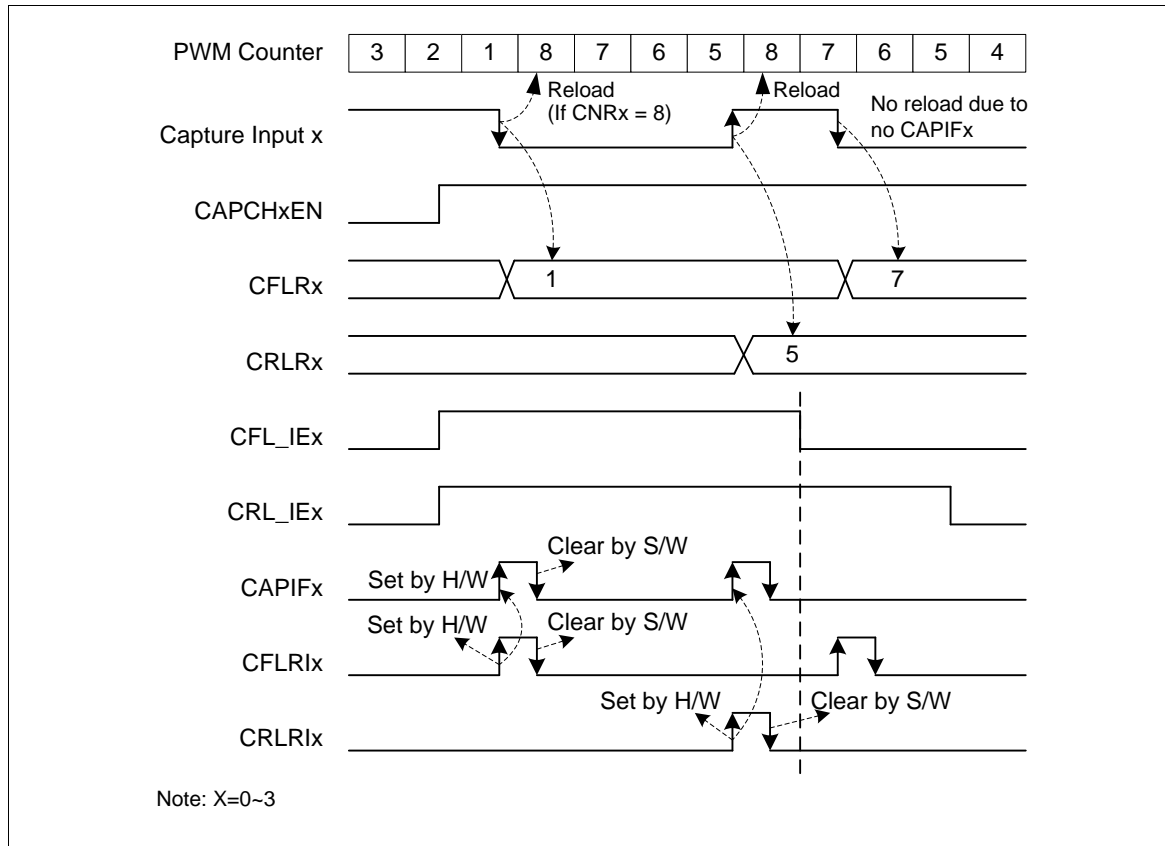

Figure 5-46 Capture Operation Timing

At this case, the CNR is 8:

1. The PWM counter will be reloaded with CNRx when a capture interrupt flag (CAPIFx) is set.
2. The channel low pulse width is $(CNR + 1 - CRLR)$.
3. The channel high pulse width is $(CNR + 1 - CFLR)$.

5.7.4.6 PWM-Timer Interrupt Architecture

There are eight PWM interrupts, PWM0_INT~PWM7_INT, which are divided into PWMA_INT and PWMB_INT for Advanced Interrupt Controller (AIC). PWM 0 and Capture 0 share one interrupt,



PWM1 and Capture 1 share the same interrupt and so on. Therefore, PWM function and Capture function in the same channel cannot be used at the same time. Figure 5-47 and Figure 5-48 demonstrates the architecture of PWM-Timer interrupts.

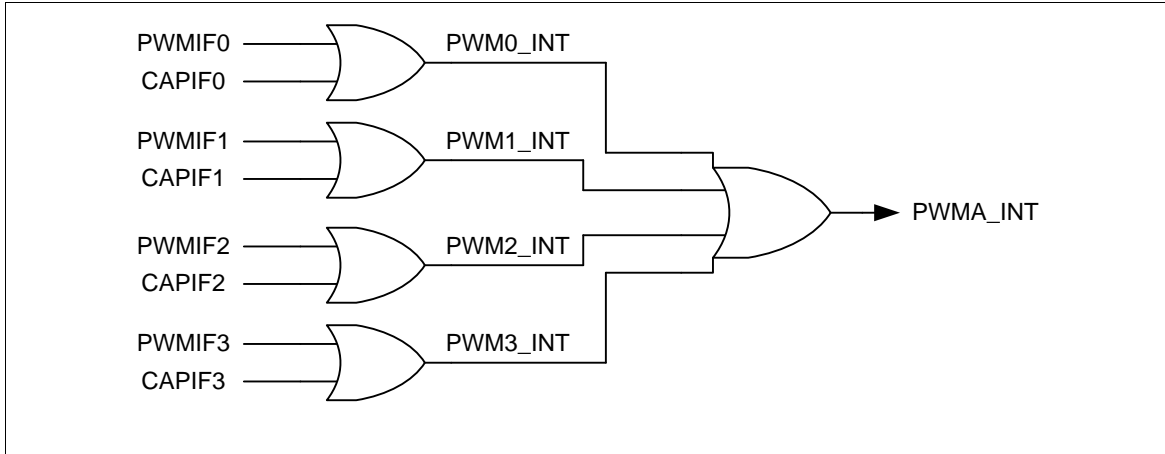

Figure 5-47 PWM Group A PWM-Timer Interrupt Architecture Diagram

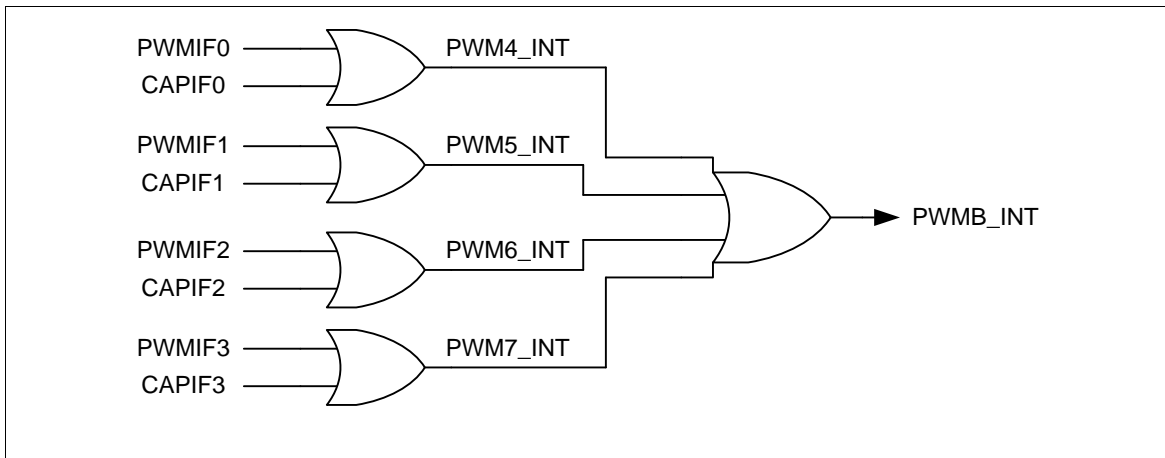

Figure 5-48 PWM Group B PWM-Timer Interrupt Architecture Diagram

5.7.4.7 PWM-Timer Start Procedure

The following procedure is recommended for starting a PWM drive.

1. Setup clock source divider select register (CSR)
2. Setup prescaler (PPR)
3. Setup inverter on/off, dead zone generator on/off, auto-reload/one-shot mode and Stop PWM-timer (PCR)
4. Setup comparator register (CMR) for setting PWM duty.
5. Setup PWM down-counter register (CNR) for setting PWM period.
6. Setup interrupt enable register (PIER) (option)
7. Setup corresponding GPIO pins as PWM function (enable POE and disable CAPENR) for the corresponding PWM channel.
8. Enable PWM timer start running (Set CHxEN = 1 in PCR)

5.7.4.8 PWM-Timer Re-Start Procedure in Single-shot mode

After PWM waveform generated once in PWM one-shot mode, PWM-Timer will stop automatically. The following procedure is recommended for re-starting PWM single-shot waveform.

1. Setup comparator register (CMR) for setting PWM duty.
2. Setup PWM down-counter register (CNR) for setting PWM period. After setup CNR, PWM wave will be generated.

5.7.4.9 PWM-Timer Stop Procedure

Method 1:

Set 16-bit down counter (CNR) as 0, and monitor PDR (current value of 16-bit down-counter). When PDR reaches to 0, disable PWM-Timer (CHxEN in PCR). (**Recommended**)

Method 2:

Set 16-bit down counter (CNR) as 0. When interrupt request happened, disable PWM-Timer (CHxEN in PCR). (**Recommended**)

Method 3:

Disable PWM-Timer directly ((CHxEN in PCR). (**Not recommended**)

The reason why method 3 is not recommended is that disable CHxEN will immediately stop PWM output signal and lead to change the duty of the PWM output, this may cause damage to the control circuit of motor



5.7.4.10 Capture Start Procedure

1. Setup clock source divider select register (CSR)
2. Setup prescaler (PPR)
3. Setup channel enabled, rising/falling interrupt enable and input signal inverter on/off (CCR0, CCR2)
4. Setup auto-reload mode, Edge-aligned type and Stop PWM-timer (PCR)
5. Setup PWM down-counter (CNR)
6. Enable PWM timer start running (Set CHxEN = 1 in PCR)
7. Wait until PWM data register (PDR) is not equal to zero to make sure PWM timer is running.
8. Setup corresponding GPIO pins as capture function (disable POE and enable CAPENR) for the corresponding PWM channel.



5.7.5 Register Map

R: read only, W: write only, R/W: both read and write

Register	Offset	R/W	Description	Reset Value
PWM Base Address:				
PWMA_BA = 0x4004_0000				
PWMB_BA = 0x4014_0000				
PPR	PWMA_BA+0x00 PWMB_BA+0x00	R/W	PWM Group A/B Pre-scale Register	0x0000_0000
CSR	PWMA_BA+0x04 PWMB_BA+0x04	R/W	PWM Group A/B Clock Source Divider Select Register	0x0000_0000
PCR	PWMA_BA+0x08 PWMB_BA+0x08	R/W	PWM Group A/B Control Register	0x0000_0000
CNR0	PWMA_BA+0x0C PWMB_BA+0x0C	R/W	PWM Group A/B Counter Register 0	0x0000_0000
CMR0	PWMA_BA+0x10 PWMB_BA+0x10	R/W	PWM Group A/B Comparator Register 0	0x0000_0000
PDR0	PWMA_BA+0x14 PWMB_BA+0x14	R	PWM Group A/B Data Register 0	0x0000_0000
CNR1	PWMA_BA+0x18 PWMB_BA+0x18	R/W	PWM Group A/B Counter Register 1	0x0000_0000
CMR1	PWMA_BA+0x1C PWMB_BA+0x1C	R/W	PWM Group A/B Comparator Register 1	0x0000_0000
PDR1	PWMA_BA+0x20 PWMB_BA+0x20	R	PWM Group A/B Data Register 1	0x0000_0000
CNR2	PWMA_BA+0x24 PWMB_BA+0x24	R/W	PWM Group A/B Counter Register 2	0x0000_0000
CMR2	PWMA_BA+0x28 PWMB_BA+0x28	R/W	PWM Group A/B Comparator Register 2	0x0000_0000
PDR2	PWMA_BA+0x2C PWMB_BA+0x2C	R	PWM Group A/B Data Register 2	0x0000_0000



CNR3	PWMA_BA+0x30 PWMB_BA+0x30	R/W	PWM Group A/B Counter Register 3	0x0000_0000
CMR3	PWMA_BA+0x34 PWMB_BA+0x34	R/W	PWM Group A/B Comparator Register 3	0x0000_0000
PDR3	PWMA_BA+0x38 PWMB_BA+0x38	R	PWM Group A/B Data Register 3	0x0000_0000
PBCR	PWMA_BA+0x3C PWMB_BA+0x3C	R/W	PWM Group A/B backward compatible Register	0x0000_0000
PIER	PWMA_BA+0x40 PWMB_BA+0x40	R/W	PWM Group A/B Interrupt Enable Register	0x0000_0000
PIIR	PWMA_BA+0x44 PWMB_BA+0x44	R/W	PWM Group A/B Interrupt Indication Register	0x0000_0000
CCR0	PWMA_BA+0x50 PWMB_BA+0x50	R/W	PWM Group A/B Capture Control Register 0	0x0000_0000
CCR2	PWMA_BA+0x54 PWMB_BA+0x54	R/W	PWM Group A/B Capture Control Register 2	0x0000_0000
CRLR0	PWMA_BA+0x58 PWMB_BA+0x58	R	PWM Group A/B Capture Rising Latch Register (Channel 0)	0x0000_0000
CFLR0	PWMA_BA+0x5C PWMB_BA+0x5C	R	PWM Group A/B Capture Falling Latch Register (Channel 0)	0x0000_0000
CRLR1	PWMA_BA+0x60 PWMB_BA+0x60	R	PWM Group A/B Capture Rising Latch Register (Channel 1)	0x0000_0000
CFLR1	PWMA_BA+0x64 PWMB_BA+0x64	R	PWM Group A/B Capture Falling Latch Register (Channel 1)	0x0000_0000
CRLR2	PWMA_BA+0x68 PWMB_BA+0x68	R	PWM Group A/B Capture Rising Latch Register (Channel 2)	0x0000_0000
CFLR2	PWMA_BA+0x6C PWMB_BA+0x6C	R	PWM Group A/B Capture Falling Latch Register (Channel 2)	0x0000_0000
CRLR3	PWMA_BA+0x70 PWMB_BA+0x70	R	PWM Group A/B Capture Rising Latch Register (Channel 3)	0x0000_0000



CFLR3	PWMA_BA+0x74 PWMB_BA+0x74	R	PWM Group A/B Capture Falling Latch Register (Channel 3)	0x0000_0000
CAPENR	PWMA_BA+0x78 PWMB_BA+0x78	R/W	PWM Group A/B Capture Input 0~3 Enable Register	0x0000_0000
POE	PWMA_BA+0x7C PWMB_BA+0x7C	R/W	PWM Group A/B Output Enable Register for channel 0~3	0x0000_0000



5.7.6 Register Description

PWM Pre-Scale Register (PPR)

Register	Offset	R/W	Description	Reset Value
PPR	PWMA_BA+0x00 PWMB_BA+0x00	R/W	PWM Group A/B Pre-scale Register	0x0000_0000

31	30	29	28	27	26	25	24
DZ123							
23	22	21	20	19	18	17	16
DZ101							
15	14	13	12	11	10	9	8
CP23							
7	6	5	4	3	2	1	0
CP01							

Bits	Description
[31:24]	<p>DZ123</p> <p>Dead Zone Interval for Pair of Channel2 and Channel3 (PWM2 and PWM3 pair for PWM group A, PWM6 and PWM7 pair for PWM group B)</p> <p>These 8-bit determine dead zone length.</p> <p>The unit time of dead zone length is received from corresponding CSR bits.</p>
[23:16]	<p>DZ101</p> <p>Dead Zone Interval for Pair of Channel 0 and Channel 1 (PWM0 and PWM1 pair for PWM group A, PWM4 and PWM5 pair for PWM group B)</p> <p>These 8-bit determine dead zone length.</p> <p>The unit time of dead zone length is received from corresponding CSR bits.</p>
[15:8]	<p>CP23</p> <p>Clock Prescaler 2 (PWM-timer2 / 3 for group A and PWM-timer 6 / 7 for group B)</p> <p>Clock input is divided by (CP23 + 1) before it is fed to the corresponding PWM-timer</p> <p>If CP23=0, then the clock prescaler 2 output clock will be stopped. So corresponding PWM-timer will be stopped also.</p>
[7:0]	<p>CP01</p> <p>Clock Prescaler 0 (PWM-timer 0 / 1 for group A and PWM-timer 4 / 5 for group B)</p> <p>Clock input is divided by (CP01 + 1) before it is fed to the corresponding PWM-timer</p> <p>If CP01=0, then the clock prescaler 0 output clock will be stopped. So corresponding PWM-timer will be stopped also.</p>



PWM Clock Source Divider Select Register (CSR)

Register	Offset	R/W	Description	Reset Value
CSR	PWMA_BA+0x04 PWMB_BA+0x04	R/W	PWM Group A/B Clock Source Divider Select Register	0x0000_0000

31	30	29	28	27	26	25	24
Reserved							
23	22	21	20	19	18	17	16
Reserved							
15	14	13	12	11	10	9	8
Reserved	CSR3			Reserved	CSR2		
7	6	5	4	3	2	1	0
Reserved	CSR1			Reserved	CSR0		

Bits	Description												
[31:15]	Reserved Reserved												
[14:12]	<p>CSR3</p> <p>PWM Timer 3 Clock Source Divider Selection (PWM timer 3 for group A and PWM timer 7 for group B) Select clock source divider for PWM timer 3.</p> <table border="1" style="margin-left: 20px;"> <thead> <tr> <th>CSR3</th> <th>Input clock divided by</th> </tr> </thead> <tbody> <tr> <td>100</td> <td>1</td> </tr> <tr> <td>011</td> <td>16</td> </tr> <tr> <td>010</td> <td>8</td> </tr> <tr> <td>001</td> <td>4</td> </tr> <tr> <td>000</td> <td>2</td> </tr> </tbody> </table>	CSR3	Input clock divided by	100	1	011	16	010	8	001	4	000	2
CSR3	Input clock divided by												
100	1												
011	16												
010	8												
001	4												
000	2												
[11]	Reserved Reserved												
[10:8]	<p>CSR2</p> <p>PWM Timer 2 Clock Source Divider Selection (PWM timer 2 for group A and PWM timer 6 for group B) Select clock source divider for PWM timer 2. (Table is the same as CSR3)</p>												
[7]	Reserved Reserved												
[6:4]	<p>CSR1</p> <p>PWM Timer 1 Clock Source Divider Selection (PWM timer 1 for group A and PWM timer 5 for group B) Select clock source divider for PWM timer 1. (Table is the same as CSR3)</p>												
[3]	Reserved Reserved												



[2:0]	CSR0	PWM Timer 0 Clock Source Divider Selection (PWM timer 0 for group A and PWM timer 4 for group B) Select clock source divider for PWM timer 0. (Table is the same as CSR3)
-------	-------------	--



PWM Control Register (PCR)

Register	Offset	R/W	Description	Reset Value
PCR	PWMA_BA+0x08 PWMB_BA+0x08	R/W	PWM Group A/B Control Register	0x0000_0000

31	30	29	28	27	26	25	24
Reserved				CH3MOD	CH3INV	Reserved	CH3EN
23	22	21	20	19	18	17	16
Reserved				CH2MOD	CH2INV	Reserved	CH2EN
15	14	13	12	11	10	9	8
Reserved				CH1MOD	CH1INV	Reserved	CH1EN
7	6	5	4	3	2	1	0
Reserved		DZEN23	DZEN01	CH0MOD	CH0INV	Reserved	CH0EN

Bits	Description
[31:28]	Reserved Reserved
[27]	CH3MOD PWM-Timer 3 Auto-reload/One-Shot Mode (PWM Timer 3 for Group A and PWM Timer 7 for Group B) 1 = Auto-reload Mode 0 = One-Shot Mode Note: If there is a transition at this bit, it will cause CNR3 and CMR3 be clear.
[26]	CH3INV PWM-Timer 3 Output Inverter Enable (PWM Timer 3 for Group A and PWM Timer 7 for Group B) 1 = Inverter Enabled 0 = Inverter Disabled
[25]	Reserved Reserved
[24]	CH3EN PWM-Timer 3 Enable (PWM Timer 3 for Group A and PWM Timer 7 for Group B) 1 = Corresponding PWM-Timer start running Enabled. 0 = Corresponding PWM-Timer running Stopped.
[23:20]	Reserved Reserved
[19]	CH2MOD PWM-Timer 2 Auto-reload/One-Shot Mode (PWM timer 2 for group A and PWM timer 6 for group B) 1 = Auto-reload Mode 0 = One-Shot Mode Note: If there is a transition at this bit, it will cause CNR2 and CMR2 be clear.
[18]	CH2INV PWM-Timer 2 Output Inverter Enable (PWM Timer 2 for Group A and PWM Timer 6 for Group B)



		1 = Inverter Enabled 0 = Inverter Disabled
[17]	Reserved	Reserved
[16]	CH2EN	PWM-Timer 2 Enable (PWM Timer 2 for Group A and PWM Timer 6 for Group B) 1 = Corresponding PWM-Timer start running Enabled. 0 = Corresponding PWM-Timer running Stopped.
[15:12]	Reserved	Reserved
[11]	CH1MOD	PWM-Timer 1 Auto-reload/One-Shot Mode (PWM Timer 1 for Group A and PWM Timer 5 for Group B) 1 = Auto-load Mode 0 = One-Shot Mode Note: If there is a transition at this bit, it will cause CNR1 and CMR1 be clear.
[10]	CH1INV	PWM-Timer 1 Output Inverter Enable (PWM Timer 1 for Group A and PWM Timer 5 for Group B) 1 = Inverter Enabled 0 = Inverter Disabled
[9]	Reserved	Reserved
[8]	CH1EN	PWM-Timer 1 Enable (PWM Timer 1 for Group A and PWM Timer 5 for Group B) 1 = Corresponding PWM-Timer start running Enabled. 0 = Corresponding PWM-Timer running Stopped.
[7:6]	Reserved	Reserved
[5]	DZEN23	Dead-Zone 2 Generator Enable (PWM2 and PWM3 Pair for PWM Group A, PWM6 and PWM7 Pair for PWM Group B) 1 = Enabled 0 = Disabled Note: When Dead-zone Generator is enabled, the pair of PWM2 and PWM3 becomes a complementary pair for PWM group A and the pair of PWM6 and PWM7 becomes a complementary pair for PWM group B.
[4]	DZEN01	Dead-Zone 0 Generator Enable (PWM0 and PWM1 Pair for PWM Group A, PWM4 and PWM5 Pair for PWM Group B) 1 = Enabled 0 = Disabled Note: When Dead-Zone Generator is enabled, the pair of PWM0 and PWM1 becomes a complementary pair for PWM group A and the pair of PWM4 and PWM5 becomes a complementary pair for PWM group B.
[3]	CH0MOD	PWM-Timer 0 Auto-reload/One-Shot Mode (PWM Timer 0 for Group A and PWM Timer 4 for Group B) 1 = Auto-reload Mode 0 = One-Shot Mode Note: If there is a transition at this bit, it will cause CNR0 and CMR0 be clear.
[2]	CH0INV	PWM-Timer 0 Output Inverter Enable (PWM Timer 0 for Group A and PWM Timer 4 for Group B) 1 = Inverter Enabled



		0 = Inverter Disabled
[1]	Reserved	Reserved
[0]	CH0EN	PWM-Timer 0 Enable (PWM Timer 0 for Group A and PWM Timer 4 for Group B) 1 = Corresponding PWM-Timer start running Enabled. 0 = Corresponding PWM-Timer running Stopped.



PWM Counter Register 3-0 (CNR3-0)

Register	Offset	R/W	Description	Reset Value
CNR0	PWMA_BA+0x0C PWMB_BA+0x0C	R/W	PWM Group A/B Counter Register 0	0x0000_0000
CNR1	PWMA_BA+0x18 PWMB_BA+0x18	R/W	PWM Group A/B Counter Register 1	0x0000_0000
CNR2	PWMA_BA+0x24 PWMB_BA+0x24	R/W	PWM Group A/B Counter Register 2	0x0000_0000
CNR3	PWMA_BA+0x30 PWMB_BA+0x30	R/W	PWM Group A/B Counter Register 3	0x0000_0000

31	30	29	28	27	26	25	24
Reserved							
23	22	21	20	19	18	17	16
Reserved							
15	14	13	12	11	10	9	8
CNRx [15:8]							
7	6	5	4	3	2	1	0
CNRx [7:0]							

Bits	Description
[31:16]	Reserved
[15:0]	<p>CNRx</p> <p>PWM Timer Loaded Value CNR determines the PWM period.</p> <ul style="list-style-type: none"> ● PWM frequency = $PWM_{xy_CLK} / [(prescale+1) * (clock\ divider) * (CNR+1)]$; where xy, could be 01, 23, 45 or 67, depends on selected PWM channel. ● Duty ratio = $(CMR+1) / (CNR+1)$. ● $CMR \geq CNR$: PWM output is always high. ● $CMR < CNR$: PWM low width = $(CNR-CMR)$ unit; PWM high width = $(CMR+1)$ unit. ● $CMR = 0$: PWM low width = (CNR) unit; PWM high width = 1 unit <p>(Unit = one PWM clock cycle)</p> <p>Note: Any write to CNR will take effect in next PWM cycle.</p>



PWM Comparator Register 3-0 (CMR3-0)

Register	Offset	R/W	Description	Reset Value
CMR0	PWMA_BA+0x10 PWMB_BA+0x10	R/W	PWM Group A/B Comparator Register 0	0x0000_0000
CMR1	PWMA_BA+0x1C PWMB_BA+0x1C	R/W	PWM Group A/B Comparator Register 1	0x0000_0000
CMR2	PWMA_BA+0x28 PWMB_BA+0x28	R/W	PWM Group A/B Comparator Register 2	0x0000_0000
CMR3	PWMA_BA+0x34 PWMB_BA+0x34	R/W	PWM Group A/B Comparator Register 3	0x0000_0000

31	30	29	28	27	26	25	24
Reserved							
23	22	21	20	19	18	17	16
Reserved							
15	14	13	12	11	10	9	8
CMRx [15:8]							
7	6	5	4	3	2	1	0
CMRx [7:0]							

Bits	Description
[31:16]	Reserved Reserved
[15:0]	<p>CMRx</p> <p>PWM Comparator Register CMR determines the PWM duty.</p> <ul style="list-style-type: none"> • PWM frequency = $PWM_{xy_CLK} / [(prescale+1) * (clock\ divider) * (CNR+1)]$; where xy, could be 01, 23, 45 or 67, depends on selected PWM channel. • Duty ratio = $(CMR+1) / (CNR+1)$. • $CMR \geq CNR$: PWM output is always high. • $CMR < CNR$: PWM low width = $(CNR - CMR)$ unit; PWM high width = $(CMR+1)$ unit. • $CMR = 0$: PWM low width = (CNR) unit; PWM high width = 1 unit <p>(Unit = one PWM clock cycle)</p> <p>Note: Any write to CMR will take effect in next PWM cycle.</p>



PWM Data Register 3-0 (PDR 3-0)

Register	Offset	R/W	Description	Reset Value
PDR0	PWMA_BA+0x14 PWMB_BA+0x14	R	PWM Group A/B Data Register 0	0x0000_0000
PDR1	PWMA_BA+0x20 PWMB_BA+0x20	R	PWM Group A/B Data Register 1	0x0000_0000
PDR2	PWMA_BA+0x2C PWMB_BA+0x2C	R	PWM Group A/B Data Register 2	0x0000_0000
PDR3	PWMA_BA+0x38 PWMB_BA+0x38	R	PWM Group A/B Data Register 3	0x0000_0000

31	30	29	28	27	26	25	24
Reserved							
23	22	21	20	19	18	17	16
Reserved							
15	14	13	12	11	10	9	8
PDR[15:8]							
7	6	5	4	3	2	1	0
PDR[7:0]							

Bits	Description	
[31:16]	Reserved	Reserved
[15:0]	PDRx	PWM Data Register User can monitor PDR to know the current value in 16-bit down counter.



PWM Backward Compatible Register

Register	Offset	R/W	Description	Reset Value
PBCR	PWMA_BA+0x3C PWMB_BA+0x3C	R/W	PWM Group A/B backward compatible Register	0x0000_0000

31	30	29	28	27	26	25	24
Reserved							
23	22	21	20	19	18	17	16
Reserved							
15	14	13	12	11	10	9	8
Reserved							
7	6	5	4	3	2	1	0
Reserved							BCn

Bits	Description	
[31:1]	Reserved	Reserved
[0]	BCn	PWM Backward Compatible Register 0 = Configure write 0 to clear CFLR10~3 and CRLR10~3. 1 = Configure write 1 to clear CFLR10~3 and CRLR10~3. Please refer to the CCR0/CCR2 register bit 6, 7, 22, 23 description



PWM Interrupt Enable Register (PIER)

Register	Offset	R/W	Description	Reset Value
PIER	PWMA_BA+0x40 PWMB_BA+0x40	R/W	PWM Group A/B Interrupt Enable Register	0x0000_0000

31	30	29	28	27	26	25	24
Reserved							
23	22	21	20	19	18	17	16
Reserved							
15	14	13	12	11	10	9	8
Reserved							
7	6	5	4	3	2	1	0
Reserved				PWMIE3	PWMIE2	PWMIE1	PWMIE0

Bits	Description	
[31:4]	Reserved	Reserved
[3]	PWMIE3	PWM channel 3 Interrupt Enable 1 = Enabled 0 = Disabled
[2]	PWMIE2	PWM channel 2 Interrupt Enable 1 = Enabled 0 = Disabled
[1]	PWMIE1	PWM channel 1 Interrupt Enable 1 = Enabled 0 = Disabled
[0]	PWMIE0	PWM channel 0 Interrupt Enable 1 = Enabled 0 = Disabled



PWM Interrupt Indication Register (PIIR)

Register	Offset	R/W	Description	Reset Value
PIIR	PWMA_BA+0x44 PWMB_BA+0x44	R/W	PWM Group A/B Interrupt Indication Register	0x0000_0000

31	30	29	28	27	26	25	24
Reserved							
23	22	21	20	19	18	17	16
Reserved							
15	14	13	12	11	10	9	8
Reserved							
7	6	5	4	3	2	1	0
Reserved				PWMIF3	PWMIF2	PWMIF1	PWMIF0

Bits	Description	
[31:4]	Reserved	Reserved
[3]	PWMIF3	PWM Channel 3 Interrupt Status This bit is set by hardware when PWM3 down counter reaches zero if PWM3 interrupt enable bit (PWMIE3) is 1, software can write 1 to clear this bit to 0
[2]	PWMIF2	PWM Channel 2 Interrupt Status This bit is set by hardware when PWM2 down counter reaches zero if PWM3 interrupt enable bit (PWMIE2) is 1, software can write 1 to clear this bit to 0
[1]	PWMIF1	PWM Channel 1 Interrupt Status This bit is set by hardware when PWM1 down counter reaches zero if PWM3 interrupt enable bit (PWMIE1) is 1, software can write 1 to clear this bit to 0
[0]	PWMIF0	PWM Channel 0 Interrupt Status This bit is set by hardware when PWM0 down counter reaches zero if PWM3 interrupt enable bit (PWMIE0) is 1, software can write 1 to clear this bit to 0

Note: User can clear each interrupt flag by writing 1 to corresponding bit in PIIR.



Capture Control Register (CCR0)

Register	Offset	R/W	Description	Reset Value
CCR0	PWMA_BA+0x50 PWMB_BA+0x50	R/W	PWM Group A/B Capture Control Register 0	0x0000_0000

31	30	29	28	27	26	25	24
Reserved							
23	22	21	20	19	18	17	16
CFLR1	CRLR1	Reserved	CAPIF1	CAPCH1EN	CFL_IE1	CRL_IE1	INV1
15	14	13	12	11	10	9	8
Reserved							
7	6	5	4	3	2	1	0
CFLR0	CRLR0	Reserved	CAPIF0	CAPCH0EN	CFL_IE0	CRL_IE0	INV0

Bits	Description
[31:24]	Reserved Reserved
[23]	CFLR1 CFLR1 Latched Indicator Bit When PWM group input channel 1 has a falling transition, CFLR1 was latched with the value of PWM down-counter and this bit is set by hardware. Software can write 0 to clear this bit to 0 if BCn bit is 0, and can write 1 to clear this bit to 0 if BCn bit is 1.
[22]	CRLR1 CRLR1 Latched Indicator Bit When PWM group input channel 1 has a rising transition, CRLR1 was latched with the value of PWM down-counter and this bit is set by hardware. Software can write 0 to clear this bit to 0 if BCn bit is 0, and can write 1 to clear this bit to 0 if BCn bit is 1.
[5]	Reserved Reserved
[20]	CAPIF1 Channel 1 Capture Interrupt Indication Flag If PWM group channel 1 rising latch interrupt is enabled (CRL_IE1=1), a rising transition occurs at PWM group channel 1 will result in CAPIF1 to high; Similarly, a falling transition will cause CAPIF1 to be set high if PWM group channel 1 falling latch interrupt is enabled (CFL_IE1=1). Write 1 to clear this bit to 0
[19]	CAPCH1EN Channel 1 Capture Function Enable 1 = Capture function on PWM group channel 1 Enabled 0 = Capture function on PWM group channel 1 Disabled When Enabled, Capture latched the PWM-counter and saved to CRLR (Rising latch) and CFLR (Falling latch). When Disabled, Capture does not update CRLR and CFLR, and disable PWM group channel 1 Interrupt.



[18]	CFL_IE1	Channel 1 Falling Latch Interrupt Enable 1 = Falling latch interrupt Enabled 0 = Falling latch interrupt Disabled When Enabled, if Capture detects PWM group channel 1 has falling transition, Capture issues an Interrupt.
[17]	CRL_IE1	Channel 1 Rising Latch Interrupt Enable 1 = Rising latch interrupt Enabled 0 = Rising latch interrupt Disabled When Enabled, if Capture detects PWM group channel 1 has rising transition, Capture issues an Interrupt.
[16]	INV1	Channel 1 Inverter Enable 1 = Inverter Enabled. Reverse the input signal from GPIO before fed to Capture timer 0 = Inverter Disabled
[15:8]	Reserved	Reserved
[7]	CFLR0	CFLR0 Latched Indicator Bit When PWM group input channel 0 has a falling transition, CFLR0 was latched with the value of PWM down-counter and this bit is set by hardware. Software can write 0 to clear this bit to 0 if BCn bit is 0, and can write 1 to clear this bit to 0 if BCn bit is 1.
[6]	CRLR0	CRLR0 Latched Indicator Bit When PWM group input channel 0 has a rising transition, CRLR0 was latched with the value of PWM down-counter and this bit is set by hardware. Software can write 0 to clear this bit to 0 if BCn bit is 0, and can write 1 to clear this bit to 0 if BCn bit is 1.
[5]	Reserved	Reserved
[4]	CAPIF0	Channel 0 Capture Interrupt Indication Flag If PWM group channel 0 rising latch interrupt is enabled (CRL_IE0=1), a rising transition occurs at PWM group channel 0 will result in CAPIF0 to high; Similarly, a falling transition will cause CAPIF0 to be set high if PWM group channel 0 falling latch interrupt is enabled (CFL_IE0=1). Write 1 to clear this bit to 0
[3]	CAPCH0EN	Channel 0 Capture Function Enable 1 = Capture function on PWM group channel 0 Enabled. 0 = Capture function on PWM group channel 0 Disabled When Enabled, Capture latched the PWM-counter value and saved to CRLR (Rising latch) and CFLR (Falling latch). When Disabled, Capture does not update CRLR and CFLR, and disable PWM group channel 0 Interrupt.
[2]	CFL_IE0	Channel 0 Falling Latch Interrupt Enable 1 = Falling latch interrupt Enabled 0 = Falling latch interrupt Disabled When Enabled, if Capture detects PWM group channel 0 has falling transition, Capture issues an Interrupt.
[1]	CRL_IE0	Channel 0 Rising Latch Interrupt Enable



		<p>1 = Rising latch interrupt Enabled 0 = Rising latch interrupt Disabled</p> <p>When Enabled, if capture detects PWM group channel 0 has rising transition, Capture issues an Interrupt.</p>
[0]	INVO	<p>Channel 0 Inverter Enable</p> <p>1 = Inverter Enabled. Reverse the input signal from GPIO before fed to Capture timer 0 = Inverter Disabled</p>



Capture Control Register (CCR2)

Register	Offset	R/W	Description	Reset Value
CCR2	PWMA_BA+0x54 PWMB_BA+0x54	R/W	PWM Group A/B Capture Control Register 2	0x0000_0000

31	30	29	28	27	26	25	24
Reserved							
23	22	21	20	19	18	17	16
CFLRI3	CRLRI3	Reserved	CAPIF3	CAPCH3EN	CFL_IE3	CRL_IE3	INV3
15	14	13	12	11	10	9	8
Reserved							
7	6	5	4	3	2	1	0
CFLRI2	CRLRI2	Reserved	CAPIF2	CAPCH2EN	CFL_IE2	CRL_IE2	INV2

Bits	Description	
[31:24]	Reserved	Reserved
[23]	CFLRI3	<p>CFLR3 Latched Indicator Bit</p> <p>When PWM group input channel 3 has a falling transition, CFLR3 was latched with the value of PWM down-counter and this bit is set by hardware.</p> <p>Software can write 0 to clear this bit to 0 if BCn bit is 0, and can write 1 to clear this bit to 0 if BCn bit is 1.</p>
[22]	CRLRI3	<p>CRLR3 Latched Indicator Bit</p> <p>When PWM group input channel 3 has a rising transition, CRLR3 was latched with the value of PWM down-counter and this bit is set by hardware.</p> <p>Software can write 0 to clear this bit to 0 if BCn bit is 0, and can write 1 to clear this bit to 0 if BCn bit is 1.</p>
[21]	Reserved	Reserved
[20]	CAPIF3	<p>Channel 3 Capture Interrupt Indication Flag</p> <p>If PWM group channel 3 rising latch interrupt is enabled (CRL_IE3 = 1), a rising transition occurs at PWM group channel 3 will result in CAPIF3 to high; Similarly, a falling transition will cause CAPIF3 to be set high if PWM group channel 3 falling latch interrupt is enabled (CFL_IE3=1).</p> <p>Write 1 to clear this bit to 0</p>
[19]	CAPCH3EN	<p>Channel 3 Capture Function Enable</p> <p>1 = Capture function on PWM group channel 3 Enabled</p> <p>0 = Capture function on PWM group channel 3 Disabled</p> <p>When Enabled, capture latched the PWM-counter and saved to CRLR (Rising latch) and CFLR (Falling latch).</p> <p>When Disabled, capture does not update CRLR and CFLR, and disable PWM group channel 3 Interrupt.</p>



[18]	CFL_IE3	<p>Channel 3 Falling Latch Interrupt Enable</p> <p>1 = Falling latch interrupt Enabled 0 = Falling latch interrupt Disabled</p> <p>When Enabled, if Capture detects PWM group channel 3 has falling transition, Capture issues an Interrupt.</p>
[17]	CRL_IE3	<p>Channel 3 Rising Latch Interrupt Enable</p> <p>1 = Rising latch interrupt Enabled 0 = Rising latch interrupt Disabled</p> <p>When Enabled, if Capture detects PWM group channel 3 has rising transition, Capture issues an Interrupt.</p>
[16]	INV3	<p>Channel 3 Inverter Enable</p> <p>1 = Inverter Enabled. Reverse the input signal from GPIO before fed to Capture timer 0 = Inverter Disabled</p>
[15:8]	Reserved	Reserved
[7]	CFLR2	<p>CFLR2 Latched Indicator Bit</p> <p>When PWM group input channel 2 has a falling transition, CFLR2 was latched with the value of PWM down-counter and this bit is set by hardware.</p> <p>Software can write 0 to clear this bit to 0 if BCn bit is 0, and can write 1 to clear this bit to 0 if BCn bit is 1.</p>
[6]	CRLR2	<p>CRLR2 Latched Indicator Bit</p> <p>When PWM group input channel 2 has a rising transition, CRLR2 was latched with the value of PWM down-counter and this bit is set by hardware.</p> <p>Software can write 0 to clear this bit to 0 if BCn bit is 0, and can write 1 to clear this bit to 0 if BCn bit is 1.</p>
[5]	Reserved	Reserved
[4]	CAPIF2	<p>Channel 2 Capture Interrupt Indication Flag</p> <p>If PWM group channel 2 rising latch interrupt is enabled (CRL_IE2=1), a rising transition occurs at PWM group channel 2 will result in CAPIF2 to high; Similarly, a falling transition will cause CAPIF2 to be set high if PWM group channel 2 falling latch interrupt is enabled (CFL_IE2=1).</p> <p>Write 1 to clear this bit to 0</p>
[3]	CAPCH2EN	<p>Channel 2 Capture Function Enable</p> <p>1 = Capture function on PWM group channel 2 Enabled 0 = Capture function on PWM group channel 2 Disabled</p> <p>When Enabled, Capture latched the PWM-counter value and saved to CRLR (Rising latch) and CFLR (Falling latch).</p> <p>When Disabled, Capture does not update CRLR and CFLR, and disable PWM group channel 2 Interrupt.</p>
[2]	CFL_IE2	<p>Channel 2 Falling Latch Interrupt Enable</p> <p>1 = Falling latch interrupt Enabled 0 = Falling latch interrupt Disabled</p> <p>When Enabled, if Capture detects PWM group channel 2 has falling transition, Capture issues an Interrupt.</p>
[1]	CRL_IE2	<p>Channel 2 Rising Latch Interrupt Enable</p>



		<p>1 = Rising latch interrupt Enabled 0 = Rising latch interrupt Disabled</p> <p>When Enabled, if Capture detects PWM group channel 2 has rising transition, Capture issues an Interrupt.</p>
[0]	INV2	<p>Channel 2 Inverter Enable</p> <p>1 = Inverter Enabled. Reverse the input signal from GPIO before fed to Capture timer 0 = Inverter Disabled</p>



Capture Rising Latch Register3-0 (CRLR3-0)

Register	Offset	R/W	Description	Reset Value
CRLR0	PWMA_BA+0x58 PWMB_BA+0x58	R	PWM Group A/B Capture Rising Latch Register (Channel 0)	0x0000_0000
CRLR1	PWMA_BA+0x60 PWMB_BA+0x60	R	PWM Group A/B Capture Rising Latch Register (Channel 1)	0x0000_0000
CRLR2	PWMA_BA+0x68 PWMB_BA+0x68	R	PWM Group A/B Capture Rising Latch Register (Channel 2)	0x0000_0000
CRLR3	PWMA_BA+0x70 PWMB_BA+0x70	R	PWM Group A/B Capture Rising Latch Register (Channel 3)	0x0000_0000

31	30	29	28	27	26	25	24
Reserved							
23	22	21	20	19	18	17	16
Reserved							
15	14	13	12	11	10	9	8
CRLRx [15:8]							
7	6	5	4	3	2	1	0
CRLRx [7:0]							

Bits	Description	
[31:16]	Reserved	Reserved
[15:0]	CRLRx	Capture Rising Latch Register Latch the PWM counter when Channel 0/1/2/3 has rising transition.



Capture Falling Latch Register3-0 (CFLR3-0)

Register	Offset	R/W	Description	Reset Value
CFLR0	PWMA_BA+0x5C PWMB_BA+0x5C	R	PWM Group A/B Capture Falling Latch Register (Channel 0)	0x0000_0000
CFLR1	PWMA_BA+0x64 PWMB_BA+0x64	R	PWM Group A/B Capture Falling Latch Register (Channel 1)	0x0000_0000
CFLR2	PWMA_BA+0x6C PWMB_BA+0x6C	R	PWM Group A/B Capture Falling Latch Register (Channel 2)	0x0000_0000
CFLR3	PWMA_BA+0x74 PWMB_BA+0x74	R	PWM Group A/B Capture Falling Latch Register (Channel 3)	0x0000_0000

31	30	29	28	27	26	25	24
Reserved							
23	22	21	20	19	18	17	16
Reserved							
15	14	13	12	11	10	9	8
CFLRx [15:8]							
7	6	5	4	3	2	1	0
CFLRx [7:0]							

Bits	Description	
[31:16]	Reserved	Reserved
[15:0]	CFLRx	Capture Falling Latch Register Latch the PWM counter when Channel 0/1/2/3 has Falling transition.



Capture Input Enable Register (CAPENR)

Register	Offset	R/W	Description	Reset Value
CAPENR	PWMA_BA+0x78 PWMB_BA+0x78	R/W	PWM Group A/B Capture Input 0~3 Enable Register	0x0000_0000

31	30	29	28	27	26	25	24
Reserved							
23	22	21	20	19	18	17	16
Reserved							
15	14	13	12	11	10	9	8
Reserved							
7	6	5	4	3	2	1	0
Reserved				CINEN3	CINEN2	CINEN1	CINEN0

Bits	Description
[31:4]	Reserved Reserved
[3]	CINEN3 Channel 3 Capture Input Enable 1 = PWM Channel 3 capture input path Enabled. The PWM channel 3 capture function input comes from correlative multifunction pin if GPIO multi-function is set as PWM3. 0 = PWM Channel 3 capture input path Disabled. The PWM channel 3 capture function's input is always saw as 0.
[2]	CINEN2 Channel 2 Capture Input Enable 1 = PWM Channel 2 capture input path Enabled. The PWM channel 2 capture function input comes from correlative multifunction pin if GPIO multi-function is set as PWM2. 0 = PWM Channel 2 capture input path Disabled. The PWM channel 2 capture function's input is always saw as 0.
[1]	CINEN1 Channel 1 Capture Input Enable 1 = PWM Channel 1 capture input path Enabled. The PWM channel 1 capture function input comes from correlative multifunction pin if GPIO multi-function is set as PWM1. 0 = PWM Channel 1 capture input path Disabled. The PWM channel 1 capture function's input is always saw as 0.
[0]	CINEN0 Channel 0 Capture Input Enable 1 = PWM Channel 0 capture input path Enabled. The PWM channel 0 capture function input comes from correlative multifunction pin if GPIO multi-function is set as PWM0. 0 = PWM Channel 0 capture input path Disabled. The PWM channel 0 capture function's input is always saw as 0.



PWM Output Enable Register (POE)

Register	Offset	R/W	Description	Reset Value
POE	PWMA_BA+0x7C PWMB_BA+0x7C	R/W	PWM Group A/B Output Enable Register for channel 0~3	0x0000_0000

31	30	29	28	27	26	25	24
Reserved							
23	22	21	20	19	18	17	16
Reserved							
15	14	13	12	11	10	9	8
Reserved							
7	6	5	4	3	2	1	0
Reserved				POE3	POE2	POE1	POE0

Bits	Description	
[3]	POE3	Channel 3 Output Enable Register 1 = PWM channel 3 output to pin Enabled 0 = PWM channel 3 output to pin Disabled Note: The corresponding GPIO pin also must be switched to PWM function
[2]	POE2	Channel 2 Output Enable Register 1 = PWM channel 2 output to pin Enabled 0 = PWM channel 2 output to pin Disabled Note: The corresponding GPIO pin also must be switched to PWM function
[1]	POE1	Channel 1 Output Enable Register 1 = PWM channel 1 output to pin Enabled 0 = PWM channel 1 output to pin Disabled Note: The corresponding GPIO pin also must be switched to PWM function
[0]	POE0	Channel 0 Output Enable Register 1 = PWM channel 0 output to pin Enabled 0 = PWM channel 0 output to pin Disabled Note: The corresponding GPIO pin also must be switched to PWM function



5.8 Real Time Clock (RTC)

5.8.1 Overview

Real Time Clock (RTC) controller provides user the real time and calendar message. The clock source of RTC is from an external 32.768 kHz low speed crystal connected at pins X32I and X32O (Refer to to pin Description) or from an external 32.768 kHz low speed oscillator output fed at pin X32I. The RTC controller provides the time message (second, minute, hour) in Time Loading Register (TLR) as well as calendar message (day, month, year) in Calendar Loading Register (CLR). The data message is expressed in BCD format. It also offers alarm function that user can preset the alarm time in Time Alarm Register (TAR) and alarm calendar in Calendar Alarm Register (CAR).

The RTC controller supports periodic Time Tick and Alarm Match interrupts. The periodic interrupt has 8 period options 1/128, 1/64, 1/32, 1/16, 1/8, 1/4, 1/2 and 1 second which are selected by TTR (TTR[2:0]). When RTC counter in TLR and CLR is equal to alarm setting time registers TAR and CAR, the alarm interrupt flag (RIIR.AIF) is set and the alarm interrupt is requested if the alarm interrupt is enabled (RIER.AIER=1). Both RTC Time Tick and Alarm Match can cause chip wake-up from Power-down mode if wake-up function is enabled (TWKE (TTR[3])=1).

5.8.2 Features

- A time counter (second, minute, hour) and calendar counter (day, month, year) for user to check the time
- Alarm register (second, minute, hour, day, month, year)
- 12-hour or 24-hour mode is selectable
- Leap year compensation automatically
- Day of week counter
- Frequency compensate register (FCR)
- All time and calendar message is expressed in BCD code
- Supports periodic time tick interrupt with 8 period options 1/128, 1/64, 1/32, 1/16, 1/8, 1/4, 1/2 and 1 second
- Supports RTC Time Tick and Alarm Match interrupt
- Supports wake-up chip from Power-down mode



5.8.3 Block Diagram

The block diagram of Real Time Clock is depicted as follows:

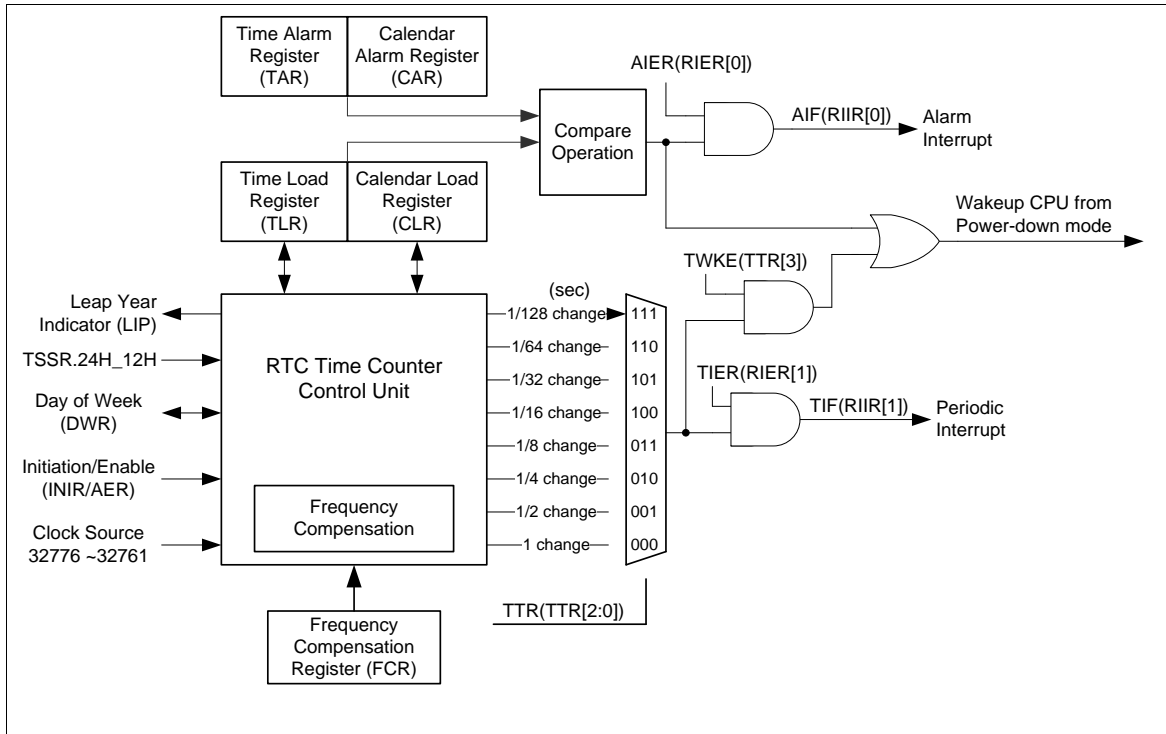

Figure 5-49 RTC Block Diagram



5.8.4 Functional Description

5.8.4.1 Access to RTC register

Due to clock difference between RTC clock and system clock, when user write new data to any one of the registers, the register will not be updated until 2 RTC clocks later (60us).

In addition, user must be aware that RTC controller does not check whether loaded data is out of bounds or not. RTC does not check rationality between DWR and CLR either.

5.8.4.2 RTC Initiation

When RTC block is powered on, RTC is at reset state. User has to write a number (0xa5eb1357) to INIR to make RTC leaving reset state. Once the INIR is written as 0xa5eb1357, the RTC will be in un-reset state permanently.

5.8.4.3 RTC Read/Write Enable

Register AER bit 15~0 is served as RTC read/write password to protect RTC registers. AER bit 15~0 has to be set as 0xA965 to enable access restriction. Once it is set, it will take effect at least 1024 RTC clocks (about 30ms). Programmer can read RTC enabled status flag in AER.ENF to check whether if RTC controller starts operating or not.

5.8.4.4 Frequency Compensation

The RTC clock source may not precise to exactly 32768 Hz and the RTC register (FCR) allows software to make digital compensation to the RTC source clock if the frequency of RTC source clock is in the range from 32761 Hz to 32776 Hz. Following are the compensation examples for higher or lower frequency clock input.

Example 1:

Frequency counter measurement : 32773.65 Hz (> 32768 Hz)

Integer part: 32773 => 0x8005

FCR.Integer = 0x05 – 0x01 + 0x08 = 0x0c

Fraction part: 0.65 x 60 = 39 => 0x27

FCR.Fraction = 0x27

Example 2

Frequency counter measurement : 32765.27 Hz (≤ 32768 Hz)

Integer part: 32765 => 0x7FFD

FCR.Integer = 0x0D – 0x01 – 0x08 = 0x04

Fraction part: 0.27 x 60 = 16.2=> 0x10

FCR.Fraction = 0x10

5.8.4.5 Time and Calendar counter

TLR and CLR are used to load the time and calendar. TAR and CAR are used for alarm. They are all represented by BCD.

5.8.4.6 12/24 hour Time Scale Selection

The 12/24 hour time scale selection depends on TSSR bit 0.

5.8.4.7 Day of the week counter

The RTC controller provides day of week in Day of the Week Register (DWR). The value is defined from 0 to 6 to represent Sunday to Saturday respectively.



5.8.4.8 Periodic Time Tick Interrupt

The periodic interrupt has 8 period option 1/128, 1/64, 1/32, 1/16, 1/8, 1/4, 1/2 and 1 second which are selected by TTR.TTR[2:0]. When periodic time tick interrupt is enabled by setting RIER.TIER to 1, the Periodic Time Tick Interrupt is requested periodically in the period selected by TTR register.

5.8.4.9 Alarm interrupt

When RTC counter in TLR and CLR is equal to alarm setting time TAR and CAR the alarm interrupt flag (RIIR.AIF) is set and the alarm interrupt is requested if the alarm interrupt is enabled (RIER.AIER=1).

5.8.4.10 Application Note:

1. TAR, CAR, TLR and CLR registers are all BCD counter.
2. Programmer has to make sure that the loaded values are reasonable. For example, Load CLR as 201a (year), 13 (month), 00 (day), or CLR does not match with DWR, etc.
3. Reset state :

Register	Reset State
AER	0
CLR	05/1/1 (year/month/day)
TLR	00:00:00 (hour : minute : second)
CAR	00/00/00 (year/month/day)
TAR	00:00:00 (hour : minute : second)
TSSR	1 (24 hr mode)
DWR	6 (Saturday)
RIER	0
RIIR	0
LIR	0
TTR	0

4. In CLR and CAR, only 2 BCD digits are used to express "year". We assume 2 BCD digits of xY denote 20xY, but not 19xY or 21xY.



5.8.5 Register Map

R: read only, W: write only, R/W: both read and write

Register	Offset	R/W	Description	Reset Value
RTC Base Address:				
RTC_BA = 0x4000_8000				
INIR	RTC_BA+0x00	R/W	RTC Initiation Register	0x0000_0000
AER	RTC_BA+0x04	R/W	RTC Access Enable Register	0x0000_0000
FCR	RTC_BA+0x08	R/W	RTC Frequency Compensation Register	0x0000_0700
TLR	RTC_BA+0x0C	R/W	Time Loading Register	0x0000_0000
CLR	RTC_BA+0x10	R/W	Calendar Loading Register	0x0005_0101
TSSR	RTC_BA+0x14	R/W	Time Scale Selection Register	0x0000_0001
DWR	RTC_BA+0x18	R/W	Day of the Week Register	0x0000_0006
TAR	RTC_BA+0x1C	R/W	Time Alarm Register	0x0000_0000
CAR	RTC_BA+0x20	R/W	Calendar Alarm Register	0x0000_0000
LIR	RTC_BA+0x24	R	RTC Leap Year Indication Register	0x0000_0000
RIER	RTC_BA+0x28	R/W	RTC Interrupt Enable Register	0x0000_0000
RIIR	RTC_BA+0x2C	R/W	RTC Interrupt Indication Register	0x0000_0000
TTR	RTC_BA+0x30	R/W	RTC Time Tick Register	0x0000_0000



5.8.6 Register Description

RTC Initiation Register (INIR)

Register	Offset	R/W	Description	Reset Value
INIR	RTC_BA+0x00	R/W	RTC Initiation Register	0x0000_0000

31	30	29	28	27	26	25	24
INIR							
23	22	21	20	19	18	17	16
INIR							
15	14	13	12	11	10	9	8
INIR							
7	6	5	4	3	2	1	0
INIR							Active

Bits	Description	
[31:0]	INIR	<p>RTC Initiation (Write only)</p> <p>When RTC block is powered on, RTC is at reset state. User has to write a number (0xa5eb1357) to INIR to make RTC leaving reset state. Once the INIR is written as 0xa5eb1357, the RTC will be in un-reset state permanently.</p> <p>The INIR is a write-only field and read value will be always "0".</p>
[0]	Active	<p>RTC Active Status (Read only)</p> <p>0 = RTC is at reset state</p> <p>1 = RTC is at normal active state.</p>



RTC Access Enable Register (AER)

Register	Offset	R/W	Description	Reset Value
AER	RTC_BA+0x04	R/W	RTC Access Enable Register	0x0000_0000

31	30	29	28	27	26	25	24
Reserved							
23	22	21	20	19	18	17	16
Reserved							ENF
15	14	13	12	11	10	9	8
AER							
7	6	5	4	3	2	1	0
AER							

Bits	Description																																																									
[31:17]	Reserved	Reserved																																																								
[16]	ENF	<p>RTC Register Access Enable Flag (Read only)</p> <p>1 = RTC register read/write Enabled 0 = RTC register read/write Disabled</p> <p>This bit will be set after AER[15:0] register is load a 0xA965, and be clear automatically 1024 RTC clock.</p> <table border="1" style="width: 100%; margin-top: 10px;"> <thead> <tr> <th>Register</th> <th>AER.ENF</th> <th>1</th> <th>0</th> </tr> </thead> <tbody> <tr><td>INIR</td><td>R/W</td><td>R/W</td><td>R/W</td></tr> <tr><td>AER</td><td>R/W</td><td>R/W</td><td>R/W</td></tr> <tr><td>FCR</td><td>R/W</td><td>-</td><td>-</td></tr> <tr><td>TLR</td><td>R/W</td><td>R</td><td>R</td></tr> <tr><td>CLR</td><td>R/W</td><td>R</td><td>R</td></tr> <tr><td>TSSR</td><td>R/W</td><td>R/W</td><td>R/W</td></tr> <tr><td>DWR</td><td>R/W</td><td>R</td><td>R</td></tr> <tr><td>TAR</td><td>R/W</td><td>-</td><td>-</td></tr> <tr><td>CAR</td><td>R/W</td><td>-</td><td>-</td></tr> <tr><td>LIR</td><td>R</td><td>R</td><td>R</td></tr> <tr><td>RIER</td><td>R/W</td><td>R/W</td><td>R/W</td></tr> <tr><td>RIIR</td><td>R/W</td><td>R/W</td><td>R/W</td></tr> <tr><td>TTR</td><td>R/W</td><td>-</td><td>-</td></tr> </tbody> </table>	Register	AER.ENF	1	0	INIR	R/W	R/W	R/W	AER	R/W	R/W	R/W	FCR	R/W	-	-	TLR	R/W	R	R	CLR	R/W	R	R	TSSR	R/W	R/W	R/W	DWR	R/W	R	R	TAR	R/W	-	-	CAR	R/W	-	-	LIR	R	R	R	RIER	R/W	R/W	R/W	RIIR	R/W	R/W	R/W	TTR	R/W	-	-
Register	AER.ENF	1	0																																																							
INIR	R/W	R/W	R/W																																																							
AER	R/W	R/W	R/W																																																							
FCR	R/W	-	-																																																							
TLR	R/W	R	R																																																							
CLR	R/W	R	R																																																							
TSSR	R/W	R/W	R/W																																																							
DWR	R/W	R	R																																																							
TAR	R/W	-	-																																																							
CAR	R/W	-	-																																																							
LIR	R	R	R																																																							
RIER	R/W	R/W	R/W																																																							
RIIR	R/W	R/W	R/W																																																							
TTR	R/W	-	-																																																							
[15:0]	AER	RTC Register Access Enable Password (Write only)																																																								



		Write 0xA965 to this register will enable RTC access and keep 1024 RTC clock
--	--	--



RTC Frequency Compensation Register (FCR)

Register	Offset	R/W	Description	Reset Value
FCR	RTC_BA+0x08	R/W	RTC Frequency Compensation Register	0x0000_0700

31	30	29	28	27	26	25	24
Reserved							
23	22	21	20	19	18	17	16
Reserved							
15	14	13	12	11	10	9	8
Reserved				INTEGER			
7	6	5	4	3	2	1	0
Reserved		FRACTION					

Bits	Description																																					
[31:12]	Reserved																																					
[11:8]	INTEGER	Integer Part																																				
		<table border="1" style="width: 100%; text-align: center;"> <thead> <tr> <th>Integer Part of Detected Value</th> <th>FCR[11:8]</th> <th>Integer Part of Detected Value</th> <th>FCR[11:8]</th> </tr> </thead> <tbody> <tr> <td>32776</td> <td>1111</td> <td>32768</td> <td>0111</td> </tr> <tr> <td>32775</td> <td>1110</td> <td>32767</td> <td>0110</td> </tr> <tr> <td>32774</td> <td>1101</td> <td>32766</td> <td>0101</td> </tr> <tr> <td>32773</td> <td>1100</td> <td>32765</td> <td>0100</td> </tr> <tr> <td>32772</td> <td>1011</td> <td>32764</td> <td>0011</td> </tr> <tr> <td>32771</td> <td>1010</td> <td>32763</td> <td>0010</td> </tr> <tr> <td>32770</td> <td>1001</td> <td>32762</td> <td>0001</td> </tr> <tr> <td>32769</td> <td>1000</td> <td>32761</td> <td>0000</td> </tr> </tbody> </table>	Integer Part of Detected Value	FCR[11:8]	Integer Part of Detected Value	FCR[11:8]	32776	1111	32768	0111	32775	1110	32767	0110	32774	1101	32766	0101	32773	1100	32765	0100	32772	1011	32764	0011	32771	1010	32763	0010	32770	1001	32762	0001	32769	1000	32761	0000
		Integer Part of Detected Value	FCR[11:8]	Integer Part of Detected Value	FCR[11:8]																																	
		32776	1111	32768	0111																																	
		32775	1110	32767	0110																																	
		32774	1101	32766	0101																																	
		32773	1100	32765	0100																																	
		32772	1011	32764	0011																																	
		32771	1010	32763	0010																																	
32770	1001	32762	0001																																			
32769	1000	32761	0000																																			
[5:0]	FRACTION	Fraction Part																																				
		Formula = (fraction part of detected value) x 60 Note: Digits in FCR must be expressed as hexadecimal number. Refer to 5.8.4.4 for the examples.																																				

Note: This register can be read back after the RTC register access enable bit ENF (AER[16]) is active.



RTC Time Loading Register (TLR)

Register	Offset	R/W	Description	Reset Value
TLR	RTC_BA+0x0C	R/W	Time Loading Register	0x0000_0000

31	30	29	28	27	26	25	24
Reserved							
23	22	21	20	19	18	17	16
Reserved		10HR			1HR		
15	14	13	12	11	10	9	8
Reserved	10MIN			1MIN			
7	6	5	4	3	2	1	0
Reserved	10SEC			1SEC			

Bits	Description	
[31:22]	Reserved	Reserved
[21:20]	10HR	10-Hour Time Digit (0~2)
[19:16]	1HR	1-Hour Time Digit (0~9)
[15]	Reserved	Reserved
[14:12]	10MIN	10-Min Time Digit (0~5)
[11:8]	1MIN	1-Min Time Digit (0~9)
[7]	Reserved	Reserved
[6:4]	10SEC	10-Sec Time Digit (0~5)
[3:0]	1SEC	1-Sec Time Digit (0~9)

Note:

1. TLR is a BCD digit counter and RTC will not check loaded data.
2. The reasonable value range is listed in the parenthesis.



RTC Calendar Loading Register (CLR)

Register	Offset	R/W	Description	Reset Value
CLR	RTC_BA+0x10	R/W	Calendar Loading Register	0x0005_0101

31	30	29	28	27	26	25	24
Reserved							
23	22	21	20	19	18	17	16
10YEAR				1YEAR			
15	14	13	12	11	10	9	8
Reserved			10MON		1MON		
7	6	5	4	3	2	1	0
Reserved		10DAY			1DAY		

Bits	Description	
[31:24]	Reserved	Reserved
[23:20]	10YEAR	10-Year Calendar Digit (0~9)
[19:16]	1YEAR	1-Year Calendar Digit (0~9)
[15:13]	Reserved	Reserved
[12]	10MON	10-Month Calendar Digit (0~1)
[11:8]	1MON	1-Month Calendar Digit (0~9)
[7:6]	Reserved	Reserved
[5:4]	10DAY	10-Day Calendar Digit (0~3)
[3:0]	1DAY	1-Day Calendar Digit (0~9)

Note:

1. CLR is a BCD digit counter and RTC will not check loaded data.
2. The reasonable value range is listed in the parenthesis.



RTC Time Scale Selection Register (TSSR)

Register	Offset	R/W	Description	Reset Value
TSSR	RTC_BA+0x14	R/W	Time Scale Selection Register	0x0000_0001

31	30	29	28	27	26	25	24
Reserved							
23	22	21	20	19	18	17	16
Reserved							
15	14	13	12	11	10	9	8
Reserved							
7	6	5	4	3	2	1	0
Reserved							24H_12H

Bits	Description																																																					
[31:1]	Reserved	Reserved																																																				
[0]	24H_12H	<p>24-Hour / 12-Hour Time Scale Selection</p> <p>It indicate that TLR and TAR are in 24-hour time scale or 12-hour time scale</p> <p>1 = select 24-hour time scale</p> <p>0 = select 12-hour time scale with AM and PM indication</p> <table border="1" style="width: 100%; text-align: center;"> <thead> <tr> <th>24-hour Time Scale</th> <th>12-hour Time Scale</th> <th>24-hour Time Scale</th> <th>12-hour Time Scale (PM time + 20)</th> </tr> </thead> <tbody> <tr><td>00</td><td>12(AM12)</td><td>12</td><td>32(PM12)</td></tr> <tr><td>01</td><td>01 (AM01)</td><td>13</td><td>21 (PM01)</td></tr> <tr><td>02</td><td>02(AM02)</td><td>14</td><td>22(PM02)</td></tr> <tr><td>03</td><td>03(AM03)</td><td>15</td><td>23(PM03)</td></tr> <tr><td>04</td><td>04 (AM04)</td><td>16</td><td>24 (PM04)</td></tr> <tr><td>05</td><td>05(AM05)</td><td>17</td><td>25(PM05)</td></tr> <tr><td>06</td><td>06(AM06)</td><td>18</td><td>26(PM06)</td></tr> <tr><td>07</td><td>07(AM07)</td><td>19</td><td>27(PM07)</td></tr> <tr><td>08</td><td>08(AM08)</td><td>20</td><td>28(PM08)</td></tr> <tr><td>09</td><td>09(AM09)</td><td>21</td><td>29(PM09)</td></tr> <tr><td>10</td><td>10 (AM10)</td><td>22</td><td>30 (PM10)</td></tr> <tr><td>11</td><td>11 (AM11)</td><td>23</td><td>31 (PM11)</td></tr> </tbody> </table>	24-hour Time Scale	12-hour Time Scale	24-hour Time Scale	12-hour Time Scale (PM time + 20)	00	12(AM12)	12	32(PM12)	01	01 (AM01)	13	21 (PM01)	02	02(AM02)	14	22(PM02)	03	03(AM03)	15	23(PM03)	04	04 (AM04)	16	24 (PM04)	05	05(AM05)	17	25(PM05)	06	06(AM06)	18	26(PM06)	07	07(AM07)	19	27(PM07)	08	08(AM08)	20	28(PM08)	09	09(AM09)	21	29(PM09)	10	10 (AM10)	22	30 (PM10)	11	11 (AM11)	23	31 (PM11)
		24-hour Time Scale	12-hour Time Scale	24-hour Time Scale	12-hour Time Scale (PM time + 20)																																																	
		00	12(AM12)	12	32(PM12)																																																	
		01	01 (AM01)	13	21 (PM01)																																																	
		02	02(AM02)	14	22(PM02)																																																	
		03	03(AM03)	15	23(PM03)																																																	
		04	04 (AM04)	16	24 (PM04)																																																	
		05	05(AM05)	17	25(PM05)																																																	
		06	06(AM06)	18	26(PM06)																																																	
		07	07(AM07)	19	27(PM07)																																																	
		08	08(AM08)	20	28(PM08)																																																	
		09	09(AM09)	21	29(PM09)																																																	
		10	10 (AM10)	22	30 (PM10)																																																	
11	11 (AM11)	23	31 (PM11)																																																			



RTC Day of the Week Register (DWR)

Register	Offset	R/W	Description	Reset Value
DWR	RTC_BA+0x18	R/W	Day of the Week Register	0x0000_0006

31	30	29	28	27	26	25	24
Reserved							
23	22	21	20	19	18	17	16
Reserved							
15	14	13	12	11	10	9	8
Reserved							
7	6	5	4	3	2	1	0
Reserved				DWR			

Bits	Description		
[31:3]	Reserved	Reserved	
[2:0]	DWR	Day of the Week Register	
		Value	Day of the Week
		0	Sunday
		1	Monday
		2	Tuesday
		3	Wednesday
		4	Thursday
		5	Friday
6	Saturday		



RTC Time Alarm Register (TAR)

Register	Offset	R/W	Description	Reset Value
TAR	RTC_BA+0x1C	R/W	Time Alarm Register	0x0000_0000

31	30	29	28	27	26	25	24
Reserved							
23	22	21	20	19	18	17	16
Reserved		10HR		1HR			
15	14	13	12	11	10	9	8
Reserved	10MIN			1MIN			
7	6	5	4	3	2	1	0
Reserved	10SEC			1SEC			

Bits	Description	
[31:22]	Reserved	Reserved
[21:20]	10HR	10-Hour Time Digit of Alarm Setting (0~2)
[19:16]	1HR	1-Hour Time Digit of Alarm Setting (0~9)
[15]	Reserved	Reserved
[14:12]	10MIN	10-Min Time Digit of Alarm Setting (0~5)
[11:8]	1MIN	1-Min Time Digit of Alarm Setting (0~9)
[7]	Reserved	Reserved
[6:4]	10SEC	10-Sec Time Digit of Alarm Setting (0~5)
[3:0]	1SEC	1-Sec Time Digit of Alarm Setting (0~9)

Note:

1. TAR is a BCD digit counter and RTC will not check loaded data.
2. The reasonable value range is listed in the parenthesis.
3. This register can be read back after the RTC register access enable bit ENF (AER[16]) is active.



RTC Calendar Alarm Register (CAR)

Register	Offset	R/W	Description	Reset Value
CAR	RTC_BA+0x20	R/W	Calendar Alarm Register	0x0000_0000

31	30	29	28	27	26	25	24
Reserved							
23	22	21	20	19	18	17	16
10YEAR				1YEAR			
15	14	13	12	11	10	9	8
Reserved			10MON		1MON		
7	6	5	4	3	2	1	0
Reserved		10DAY			1DAY		

Bits	Description	
[31:24]	Reserved	Reserved
[23:20]	10YEAR	10-Year Calendar Digit of Alarm Setting (0~9)
[19:16]	1YEAR	1-Year Calendar Digit of Alarm Setting (0~9)
[15:13]	Reserved	Reserved
[12]	10MON	10-Month Calendar Digit of Alarm Setting (0~1)
[11:8]	1MON	1-Month Calendar Digit of Alarm Setting (0~9)
[7:6]	Reserved	Reserved
[5:4]	10DAY	10-Day Calendar Digit of Alarm Setting (0~3)
[3:0]	1DAY	1-Day Calendar Digit of Alarm Setting (0~9)

Note:

- CAR is a BCD digit counter and RTC will not check loaded data.
- The reasonable value range is listed in the parenthesis.
- This register can be read back after the RTC register access enable bit ENF (AER[16]) is active.



RTC Leap Year Indication Register (LIR)

Register	Offset	R/W	Description	Reset Value
LIR	RTC_BA+0x24	R	RTC Leap Year Indication Register	0x0000_0000

31	30	29	28	27	26	25	24
Reserved							
23	22	21	20	19	18	17	16
Reserved							
15	14	13	12	11	10	9	8
Reserved							
7	6	5	4	3	2	1	0
Reserved							LIR

Bits	Description
[31:1]	Reserved
[0]	<p>Leap Year Indication Register (Real only).</p> <p>1 = This year is leap year</p> <p>0 = This year is not a leap year</p>



RTC Interrupt Enable Register (RIER)

Register	Offset	R/W	Description	Reset Value
RIER	RTC_BA+0x28	R/W	RTC Interrupt Enable Register	0x0000_0000

31	30	29	28	27	26	25	24
Reserved							
23	22	21	20	19	18	17	16
Reserved							
15	14	13	12	11	10	9	8
Reserved							
7	6	5	4	3	2	1	0
Reserved						TIER	AIER

Bits	Description	
[31:2]	Reserved	Reserved
[1]	TIER	Time Tick Interrupt Enable 1 = RTC Time Tick Interrupt Enabled 0 = RTC Time Tick Interrupt Disabled
[0]	AIER	Alarm Interrupt Enable 1 = RTC Alarm Interrupt Enabled 0 = RTC Alarm Interrupt Disabled



RTC Interrupt Indication Register (RIIR)

Register	Offset	R/W	Description	Reset Value
RIIR	RTC_BA+0x2C	R/W	RTC Interrupt Indication Register	0x0000_0000

31	30	29	28	27	26	25	24
Reserved							
23	22	21	20	19	18	17	16
Reserved							
15	14	13	12	11	10	9	8
Reserved							
7	6	5	4	3	2	1	0
Reserved						TIF	AIF

Bits	Description	
[31:2]	Reserved	Reserved
[1]	TIF	<p>RTC Time Tick Interrupt Flag</p> <p>When RTC Time Tick Interrupt is enabled (RIER.TIER = 1), RTC controller will set TIF to high periodically in the period selected by TTR[2:0]. This bit is software clear by writing 1 to it.</p> <p>1= RTC Time Tick Interrupt is requested if RIER.TIER=1 0= RCT Time Tick Interrupt condition never occurred.</p>
[0]	AIF	<p>RTC Alarm Interrupt Flag</p> <p>When RTC Alarm Interrupt is enabled (RIER.AIER = 1), RTC controller will set AIF to high once the RTC real time counters TLR and CLR reach the alarm setting time registers TAR and CAR. This bit is software clear by writing 1 to it.</p> <p>1= RTC Alarm Interrupt is requested if RIER.AIER = 1 0= RTC Alarm Interrupt condition never occurred.</p>



RTC Time Tick Register (TTR)

Register	Offset	R/W	Description	Reset Value
TTR	RTC_BA+0x30	R/W	RTC Time Tick Register	0x0000_0000

31	30	29	28	27	26	25	24
Reserved							
23	22	21	20	19	18	17	16
Reserved							
15	14	13	12	11	10	9	8
Reserved							
7	6	5	4	3	2	1	0
Reserved				TWKE	TTR[2:0]		

Bits	Description																			
[31:4]	Reserved	Reserved																		
[3]	TWKE	<p>RTC Timer Wake-up Function Enable</p> <p>If TWKE is set before chip is in Power-down mode, chip will be woken up by RTC controller when a RTC Time Tick occurs.</p> <p>1 = RTC Timer wake-up function Enabled so that chip can be woken up from Power-down mode by Time Tick.</p> <p>0 = RTC Timer wake-up Disabled by Timer Tick occur function.</p> <p>Note: Tick timer setting follows TTR[2:0] description.</p> <p>Note: When Alarm Match occurs, chip will be woken-up from Power-down mode no matter TWKE is 1 or 0.</p>																		
[2:0]	TTR	<p>Time Tick Register</p> <p>The RTC time tick period for Periodic Time Tick Interrupt request.</p> <table border="1" style="width: 100%; margin-top: 5px;"> <thead> <tr> <th>TTR[2:0]</th> <th>Time tick (second)</th> </tr> </thead> <tbody> <tr><td>0</td><td>1</td></tr> <tr><td>1</td><td>1/2</td></tr> <tr><td>2</td><td>1/4</td></tr> <tr><td>3</td><td>1/8</td></tr> <tr><td>4</td><td>1/16</td></tr> <tr><td>5</td><td>1/32</td></tr> <tr><td>6</td><td>1/64</td></tr> <tr><td>7</td><td>1/128</td></tr> </tbody> </table> <p>Note: This register can be read back after the RTC register access enable bit ENF (AER[16]) is active.</p>	TTR[2:0]	Time tick (second)	0	1	1	1/2	2	1/4	3	1/8	4	1/16	5	1/32	6	1/64	7	1/128
TTR[2:0]	Time tick (second)																			
0	1																			
1	1/2																			
2	1/4																			
3	1/8																			
4	1/16																			
5	1/32																			
6	1/64																			
7	1/128																			

5.9 Serial Peripheral Interface (SPI)

5.9.1 Overview

The Serial Peripheral Interface (SPI) is a synchronous serial data communication protocol which operates in full duplex mode. Devices communicate in master/Slave mode with 4-wire bi-direction interface. The NuMicro™ NUC130/NUC140 contains up to four sets of SPI controller performing a serial-to-parallel conversion on data received from a peripheral device, and a parallel-to-serial conversion on data transmitted to a peripheral device. Each set of SPI controller can be set as a master, it also can be configured as a slave device controlled by an off-chip master device.

This controller supports a variable serial clock for special application and it also supports 2-bit transfer mode to connect 2 off-chip slave devices at the same time. The SPI controller also supports PDMA function to access the data buffer.

5.9.2 Features

- Up to four sets of SPI controller
- Supports master or Slave mode operation
- Supports 1-bit or 2-bit transfer mode
- Configurable bit length up to 32-bit of a transfer word and configurable word numbers up to 2 of a transaction, so the maximum bit length is 64-bit for each data transfer
- Provides Burst mode operation, transmit/receive can be transferred up to two times word transaction in one transfer
- Supports MSB or LSB first transfer
- Two device/slave select lines in Master mode, but 1 device/slave select line in Slave mode
- Supports byte reorder function
- Supports byte or word suspend mode
- Variable output serial clock frequency in Master mode
- Supports two programmable serial clock frequencies in Master mode
- Supports two channel PDMA request, one for transmitter and another for receiver
- Supports three wire, no slave select signal, bi-direction interface
- SPI clock rate can be configured to equal to the system clock rate



5.9.3 Block Diagram

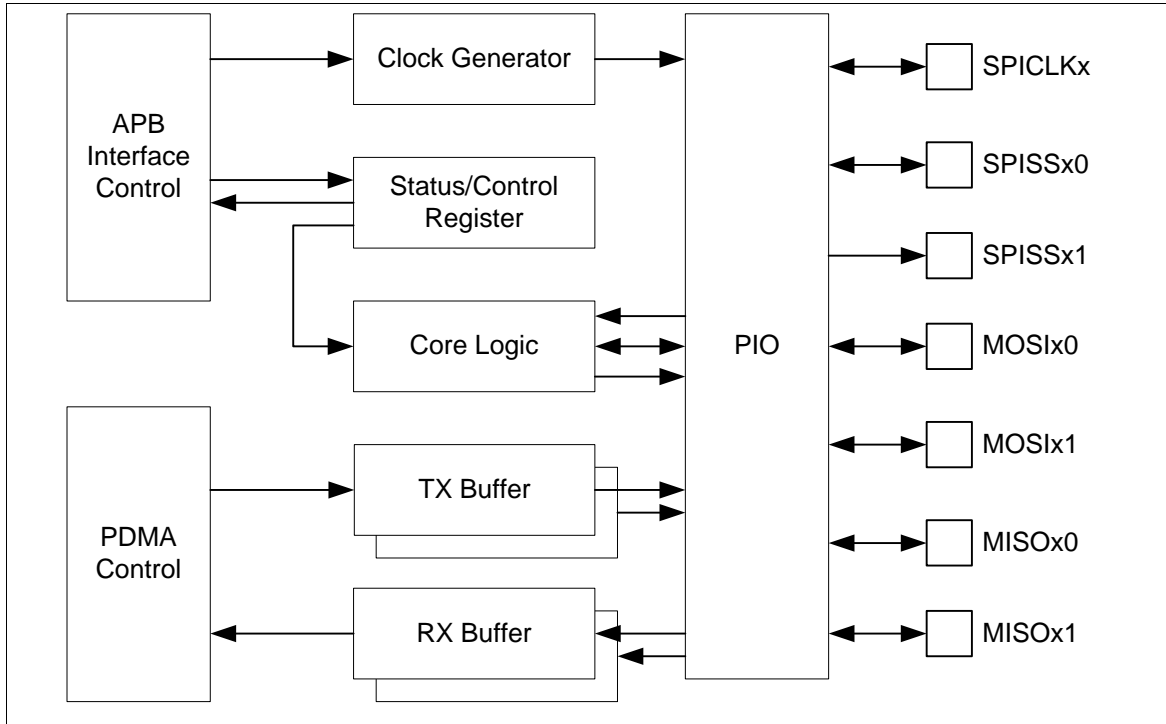

Figure 5-50 SPI Block Diagram

5.9.4 Functional Description

Master/Slave Mode

This SPI controller can be set as master or Slave mode by setting the SLAVE bit (SPI_CNTRL[18]) to communicate with the off-chip SPI slave or master device. The application block diagrams in Master and Slave mode are shown below.

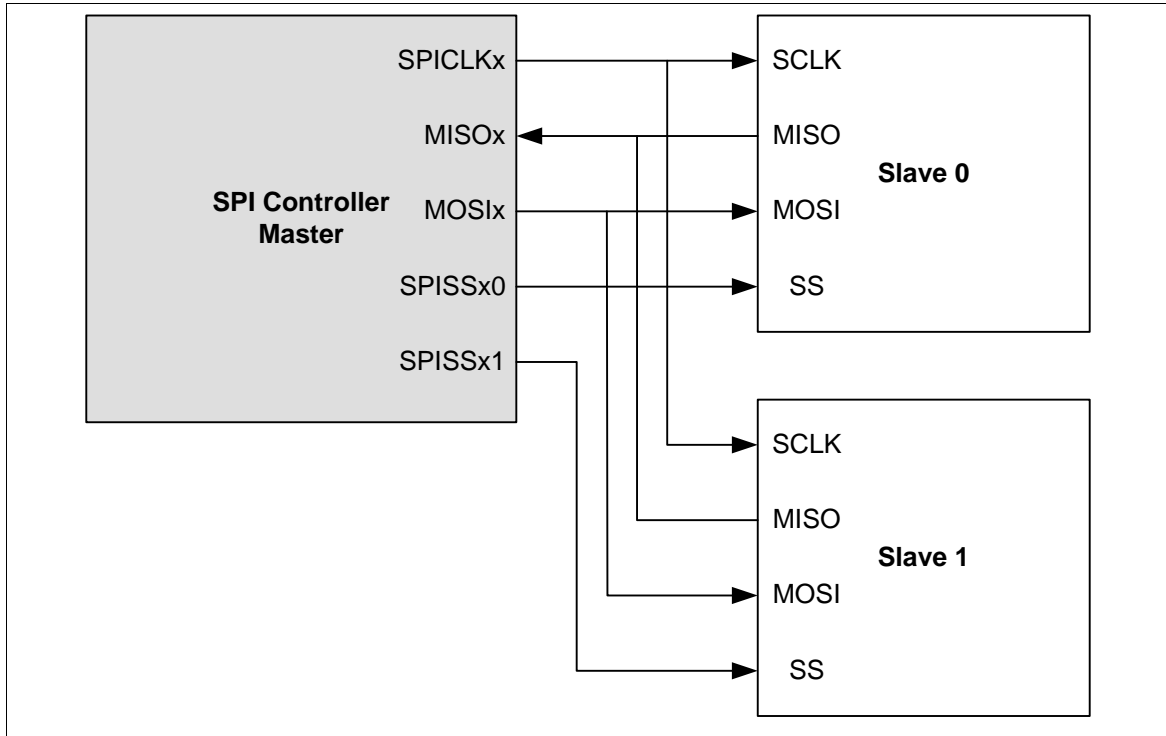

Figure 5-51 SPI Master Mode Application Block Diagram

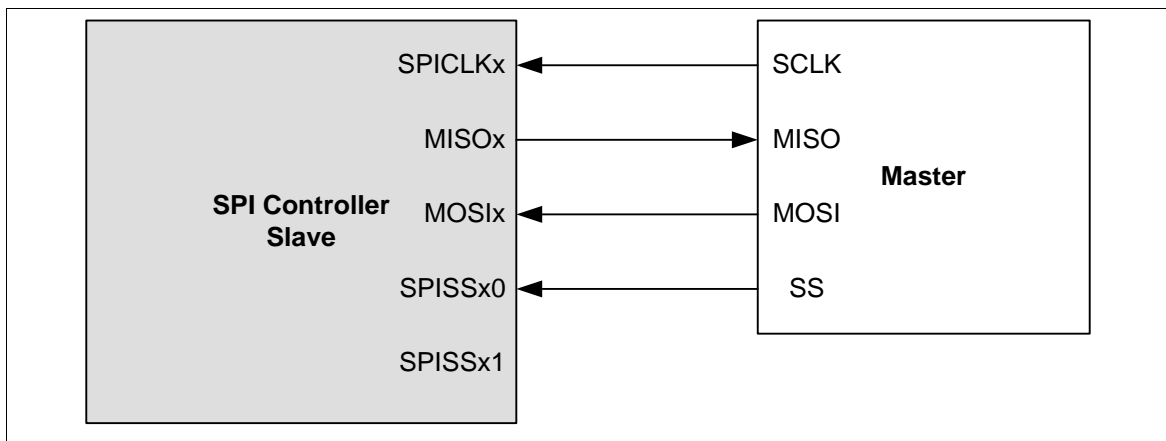

Figure 5-52 SPI Slave Mode Application Block Diagram



Slave Selection

In Master mode, this SPI controller can drive up to two off-chip slave devices through the slave select output pins SPISSx0 and SPISSx1. In Slave mode, the off-chip master device drives the slave select signal from the SPISSx0 input port to this SPI controller. In master/Slave mode, the active state of slave select signal can be programmed to low active or high active in SS_LVL bit (SPI_SSR[2]), and the SS_LTRIG bit (SPI_SSR[4]) defines the slave select signal SPISSx0/1 is level trigger or edge trigger. The selection of trigger condition depends on what type of peripheral slave/master device is connected.

In Slave mode, if the SS_LTRIG bit is configured as level trigger, the LTRIG_FLAG bit (SPI_SSR[5]) is used to indicate if both the received number and received bits met the requirement which defines in TX_NUM and TX_BIT_LEN among one transaction done (the transaction done means the slave select has deactivated or the SPI controller has finished one data transfer.)

Level-trigger / Edge-trigger

In Slave mode, the slave select signal can be configured as level-trigger or edge-trigger. In edge-trigger, the data transfer starts from an active edge and ends on an inactive edge. If master does not send an inactive edge to slave, the transfer procedure will not be completed and the interrupt flag of slave will not be set. In level-trigger, the following two conditions will terminate the transfer procedure and the interrupt flag of slave will be set. The first condition is that if the number of transferred bits matches the settings of TX_NUM and TX_BIT_LEN, the interrupt flag of slave will be set. The second condition, if master set the slave select pin to inactive level during the transfer is in progress, it will force slave device to terminate the current transfer no matter how many bits have been transferred and the interrupt flag will be set. User can read the status of LTRIG_FLAG bit to check if the data has been completely transferred.

Automatic Slave Selection

In Master mode, if the bit AUTOSS (SPI_SSR[3]) is set, the slave select signals will be generated automatically and output to SPISSx0 and SPISSx1 pins depending on whether the SSR[0] (SPI_SSR[0]) and SSR[1] (SPI_SSR[1]) is enabled or not. It means that the slave select signals, which are selected in SSR[1:0], will be asserted by the SPI controller when transmit/receive is started by setting the GO_BUSY bit (SPI_CNTRL[0]) and will be de-asserted after the data transfer is finished. If the AUTOSS bit is cleared, the slave select output signals will be asserted/de-asserted by manual setting/clearing the related bits of SPI_SSR[1:0]. The active state of the slave select output signals is specified in SS_LVL bit (SPI_SSR[2]).

Serial Clock

In Master mode, set the DIVIDER1 bits (SPI_DIVIDER[15:0]) to program the output frequency of serial clock to the SPICLK output port. It also supports a variable serial clock if the VARCLK_EN bit (SPI_CTL[23]) is enabled. In this case, the output frequency of serial clock can be programmed as one of the two different frequencies which depend on the value of DIVIDER1 (SPI_DIVIDER[15:0]) and DIVIDER2 (SPI_DIVIDER[31:16]). The serial clock rate of each cycle is depended on the setting of the SPI_VARCLK register.

In Slave mode, the off-chip master device drives the serial clock through the SPICLK input port to this SPI controller.

Variable Serial Clock Frequency

In Master mode, the output of serial clock can be programmed as variable frequency pattern if the Variable Clock Enable bit VARCLK_EN (SPI_CNTRL[23]) is enabled. The frequency pattern format is defined in VARCLK (SPI_VARCLK[31:0]) register. If the bit content of VARCLK is '0' the output frequency is according with the DIVIDER (SPI_DIVIDER[15:0]) and if the bit content of VARCLK is '1', the output frequency is according to the DIVIDER2 (SPI_DIVIDER[31:16]). Figure 5-53 is the timing relationship among the serial clock (SPICLK), the VARCLK, the DIVIDER and the DIVIDER2 registers. A two-bit combination in the VARCLK defines one clock cycle. The bit field VARCLK[31:30] defines the first clock cycle of SPICLK. The bit field VARCLK[29:28] defines the second clock cycle of SPICLK and so on. The clock source selections are defined in VARCLK and it must be set 1 cycle before the next clock option. For example, if there are 5 CLK1 cycle in SPICLK, the VARCLK shall set 9 '0' in the MSB of VARCLK. The 10th shall be set as '1' in order to switch the next clock source is CLK2. Note that when the VARCLK_EN bit is enabled, the setting of TX_BIT_LEN must be programmed as 0x10 (16-bit mode only).

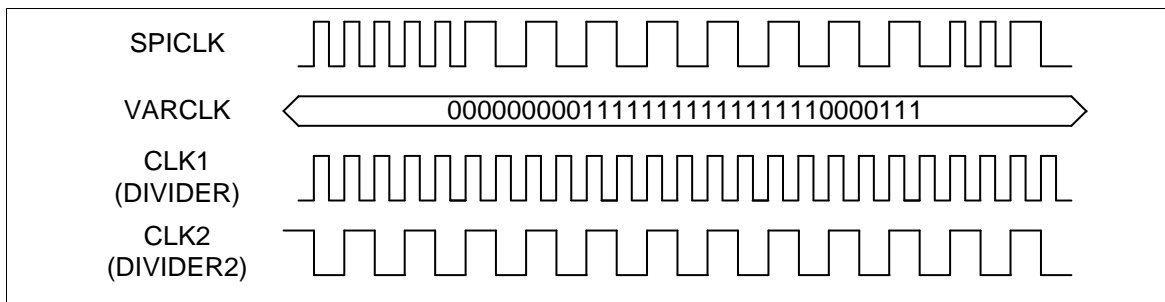

Figure 5-53 Variable Serial Clock Frequency

Clock Polarity

The CLKP bit (SPI_CTL[11]) defines the serial clock idle state. If CLKP = 1, the output SPICLK is idle at high state, otherwise it is at low state if CLKP = 0.

Transmit/Receive Bit Length

The bit length of a transaction word is defined in TX_BIT_LEN bit field (SPI_CNTRL[7:3]). It can be configured up to 32-bit length in a transaction word for transmitting and receiving.

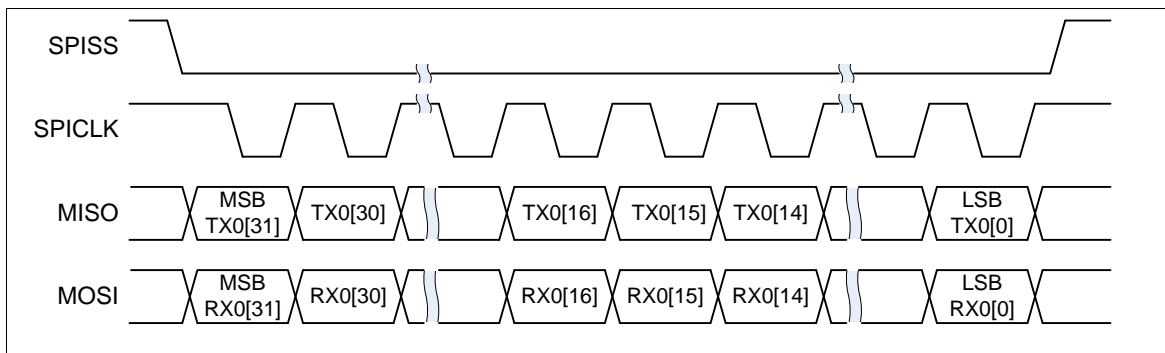

Figure 5-54 32-Bit in One Transaction

Burst Mode

SPI controller can switch to Burst mode by setting TX_NUM bit field (SPI_CNTRL[9:8]) to 0x01. In Burst mode, SPI can transmit/receive two transactions in one transfer. The SPI Burst mode waveform is shown below.

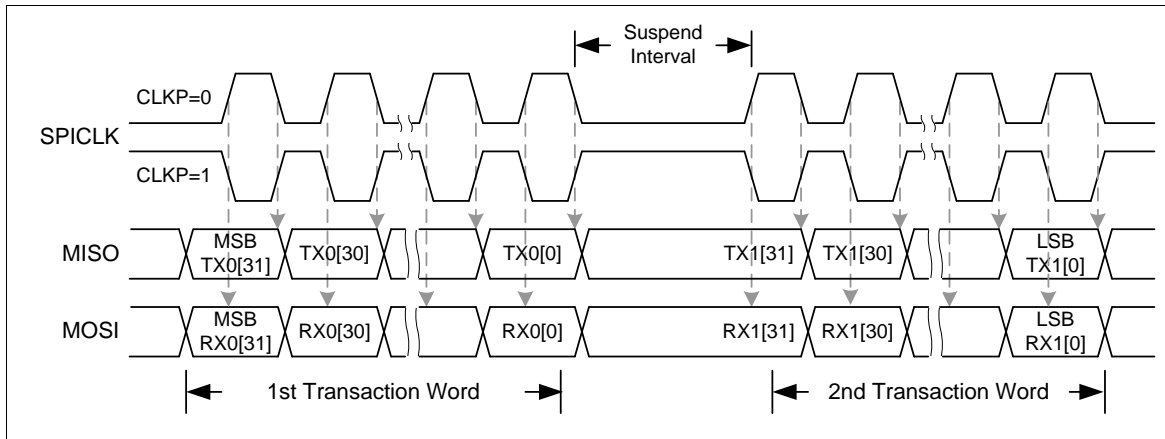

Figure 5-55 Two Transactions in One Transfer (Burst Mode)

LSB First

The LSB bit (SPI_CNTRL[10]) defines the data transmission either from LSB or MSB firstly to start to transmit/receive data.

Transmit Edge

The TX_NEG bit (SPI_CNTRL[2]) defines the data transmitted out either at negative edge or at positive edge of serial clock SPICLK.

Receive Edge

The Rx_NEG bit (SPI_CNTRL[1]) defines the data received in either at negative edge or at positive edge of serial clock SPICLK.

Note: the settings of TX_NEG and RX_NEG are mutual exclusive. In other words, don't transmit and receive data at the same clock edge.

Word Suspend

These four bits field of SP_CYCLE (SPI_CNTRL[15:12]) provide a configurable suspend interval 2 ~ 17 serial clock periods between two successive transaction words in Master mode. The suspend interval is from the last falling clock edge of the preceding transaction word to the first rising clock edge of the following transaction word if CLKP = 0. If CLKP = 1, the interval is from the rising clock edge of the preceding transaction word to the falling clock edge of the following transaction word. The default value of SP_CYCLE is 0x0 (2 serial clock cycles), but set these bits field has no any effects on data transaction process if TX_NUM = 0x00.

Byte Reorder

When the transfer is set as MSB first (LSB = 0) and the REORDER is enabled, the data stored in the TX buffer and RX buffer will be rearranged in the order as [BYTE0, BYTE1, BYTE2, BYTE3] in TX_BIT_LEN = 32-bit mode, and the sequence of transmitted/received data will be BYTE0, BYTE1, BYTE2, and then BYTE3. If the TX_BIT_LEN is set as 24-bit mode, the data in TX buffer and RX buffer will be rearranged as [unknown byte, BYTE0, BYTE1, BYTE2]. The SPI controller will transmit/receive data with the sequence of BYTE0, BYTE1 and then BYTE2. Each byte will be transmitted/received with MSB first. The rule of 16-bit mode is the same as above. Byte reorder function is only available when TX_BIT_LEN is configured as 16, 24, and 32 bits.

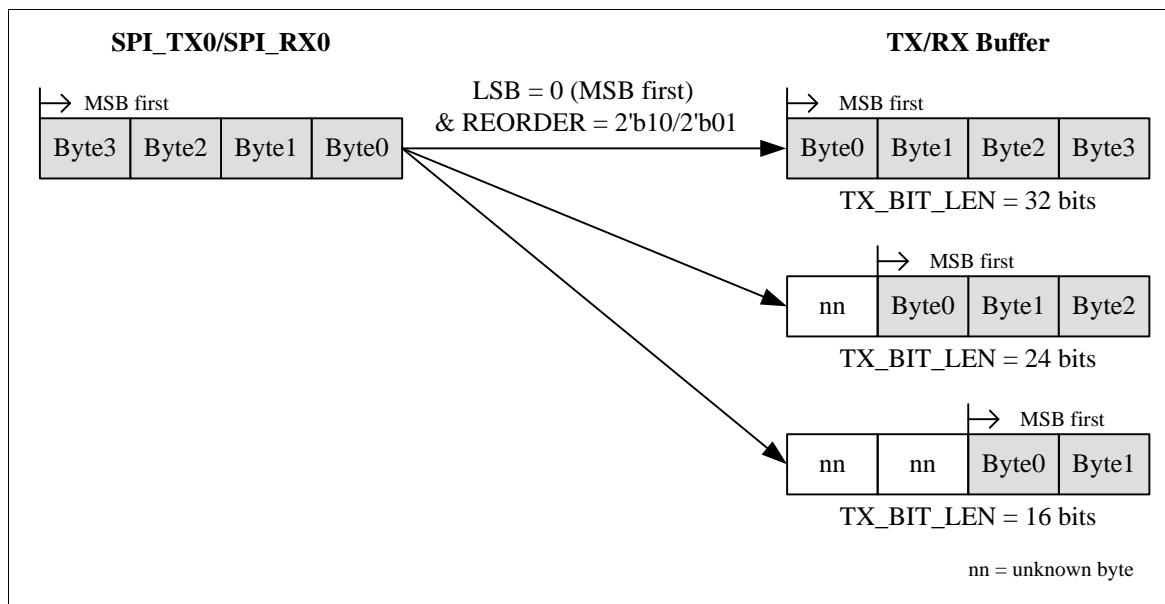

Figure 5-56 Byte Reorder

Byte Suspend

In Master mode, if SPI_CNTRL[19] is set to 1, the hardware will insert a suspend interval 2 ~ 17 serial clock periods between two successive bytes in a transaction word. Both settings of byte suspend and word suspend are configured in SP_CYCLE. Note that when the byte suspend function is enabled, the setting of TX_BIT_LEN must be programmed as 0x00 only (32-bit per transaction word).

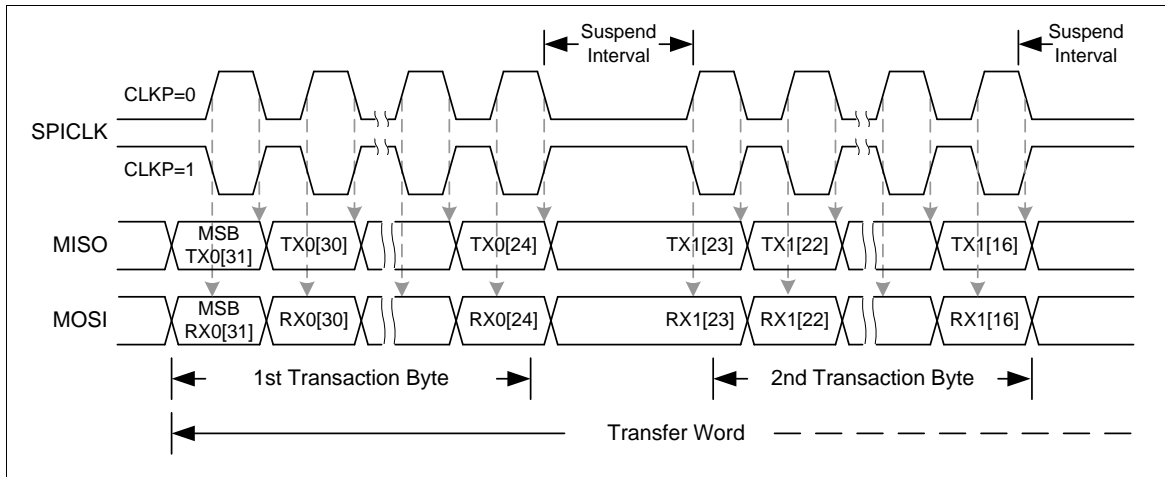

Figure 5-57 Timing Waveform for Byte Suspend

REORDER	Description
00	Disable both byte reorder function and byte suspend interval.
01	Enable byte reorder function and insert a byte suspend interval (2~17 SPICLK) among each byte. The setting of TX_BIT_LEN must be configured as 0x00 (32 bits/ word)
10	Enable byte reorder function but disable byte suspend function
11	Disable byte reorder function, but insert a suspend interval (2~17 SPICLK) among each byte. The setting of TX_BIT_LEN must be configured as 0x00 (32 bits/ word)

Table 5-7 Byte Order and Byte Suspend Conditions

No Slave Select Mode (3-WIRE Mode)

This is used to ignore the slave select signal in Slave mode. The SPI controller can work on no slave select mode (3-WIRE mode) interface including SPICLK, SPI_MISO, and SPI_MOSI when it is set as a slave device. When the NOSLVSEL bit is set as 1, the controller will start to transmit/receive data after the GO_BUSY bit is set to 1 and the serial clock appears. In no slave select signal mode, the SS_LTRIG, SPI_SSR[4], shall be set as 1.



Interrupt

Each SPI controller can generate an individual interrupt when data transfer is finished and the respective interrupt event flag IF (SPI_CNTRL[16]) will be set. The interrupt event flag will generate an interrupt to CPU if the interrupt enable bit IE (SPI_CNTRL[17]) is set. The interrupt event flag **IF** can be cleared only by writing 1 to it.

In 3-WIRE mode, the interrupt flag in SLV_START_INTSTS will be set when the transfer has start and there is also interrupt event when the received data meet the required bits which define in TX_BIT_LEN and TX_NUM. If the received bits are less than the requirement and there is no more serial clock input over the time period which is defined by the user in Slave mode with no slave select, the user can set the SLV_ABORT bit to force the current transfer done and then the user can get a transfer done interrupt event.

Two Bit Transfer Mode

This SPI controller also supports two-bit transfer mode when set the TWOB bit (SPI_CNTRL[22]) to 1. When the TWOB bit is enabled, it can transmit and receives two-bit serial data simultaneously.

For example, in Master mode, the data stored at SPI_TX0 register and SPI_TX1 register will be transmitted through the MOSIx0 pin and MOSIx1 pin respectively. In the meanwhile, the SPI_RX0 register and SPI_RX1 register will store the data received from MISOx0 pin and MISOx1 pin respectively.

In Slave mode, the data stored at SPI_TX0 register and SPI_TX1 register will be transmitted through the MISOx0 pin and MISOx1 pin respectively. In the meanwhile, the SPI_RX0 register and SPI_RX1 register will store the data received from MOSIx0 pin and MOSIx1 pin respectively.

Note that when the TWOB bit is enabled, the setting of TX_NUM must be programmed as 0x00 only.

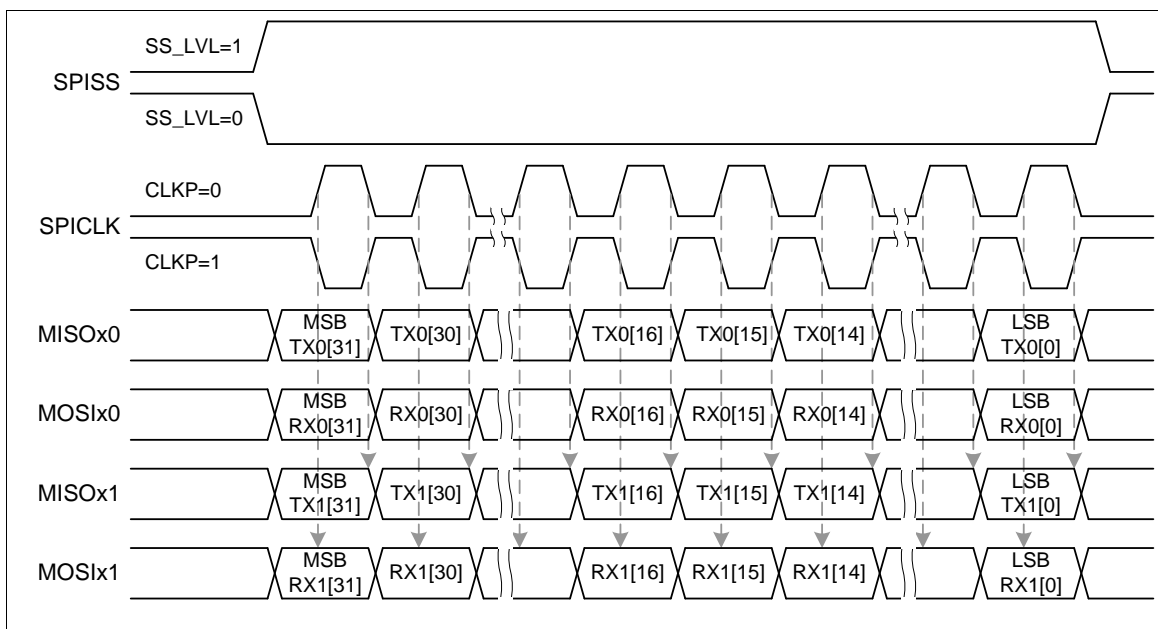

Figure 5-58 Two Bits Transfer Mode (Slave Mode)



5.9.5 Timing Diagram

The active state of slave select signal can be defined by the settings of SS_LVL bit (SPI_SSR[2]) and SS_LTRIG bit (SPI_SSR[4]). The serial clock (SPICLK) idle state can be configured as high state or low state by setting the CLKP bit (SPI_CNTRL[11]). It also provides the bit length of a transaction word in TX_BIT_LEN (SPI_CNTRL[7:3]), the transfer number in TX_NUM (SPI_CNTRL[8]), and transmit/receive data from MSB or LSB first in LSB bit (SPI_CNTRL[10]). Users also can select which edge of serial clock to transmit/receive data in TX_NEG/RX_NEG (SPI_CNTRL[2:1]) registers. Four SPI timing diagrams for master/slave operations and the related settings are shown below.

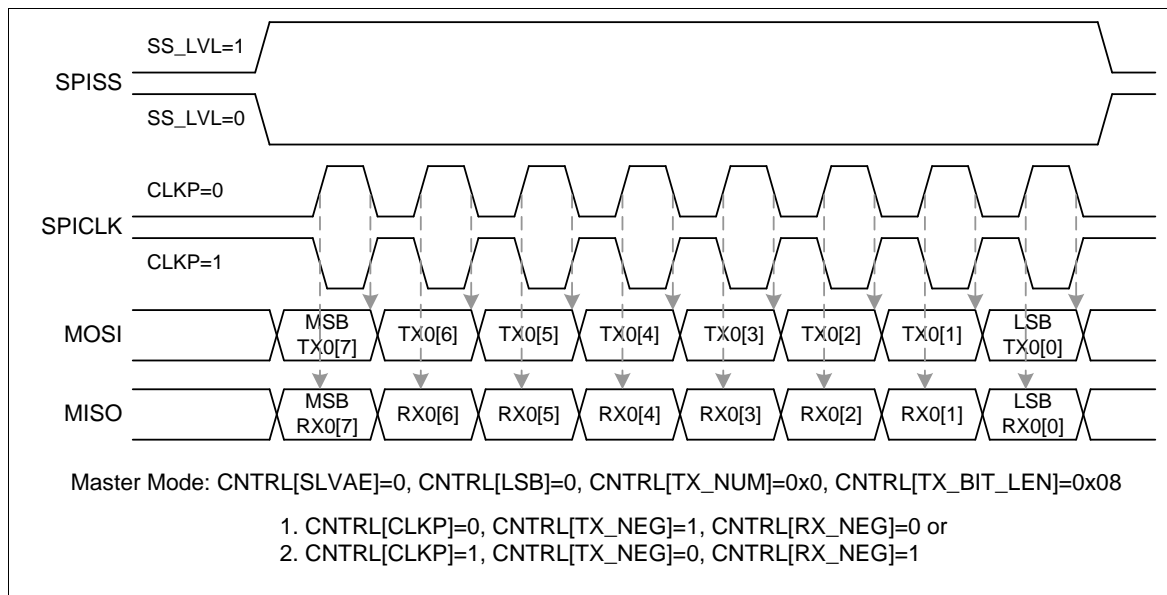

Figure 5-59 SPI Timing in Master Mode

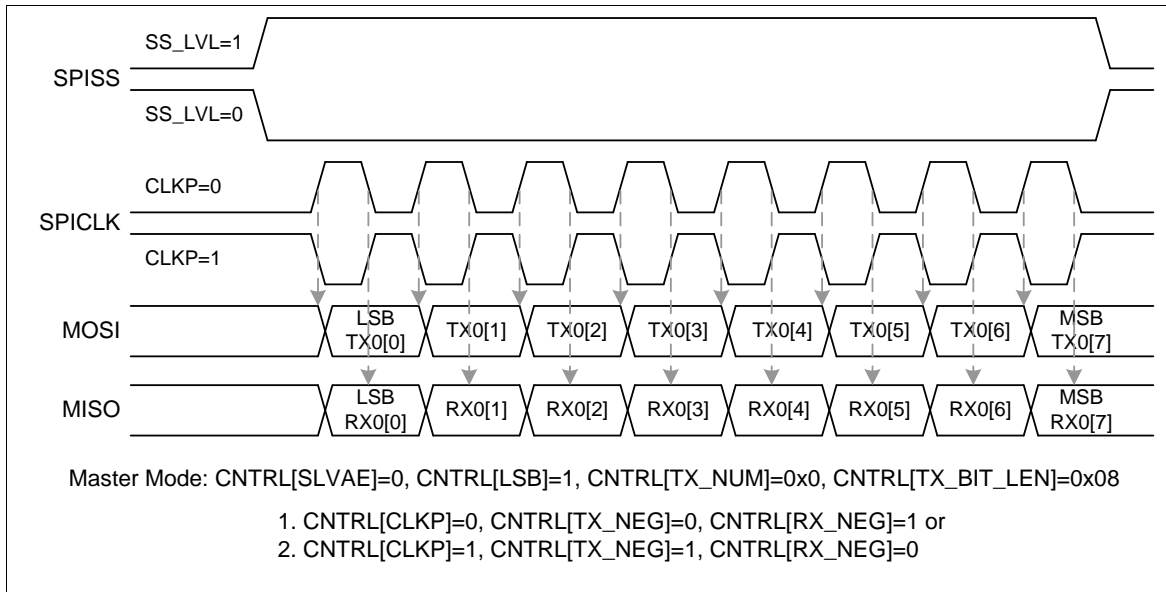

Figure 5-60 SPI Timing in Master Mode (Alternate Phase of SPICLK)

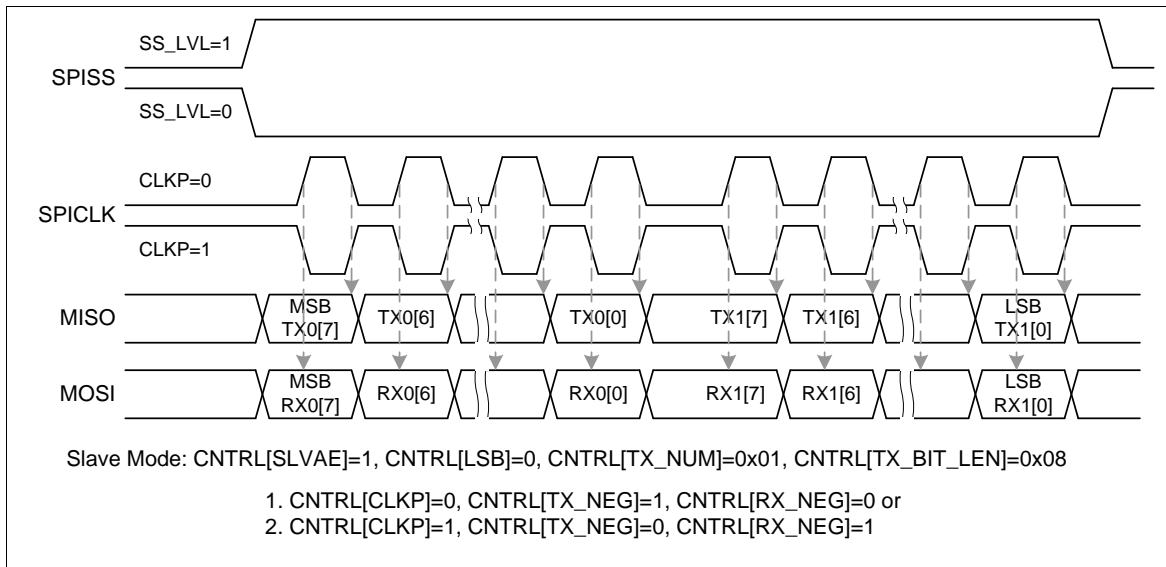

Figure 5-61 SPI Timing in Slave Mode

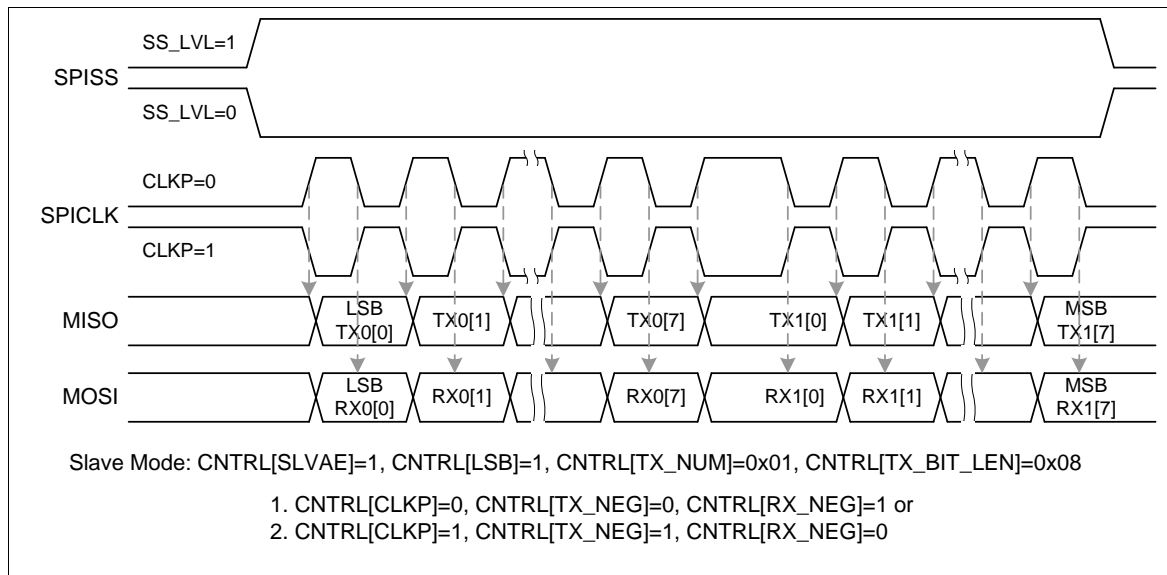

Figure 5-62 SPI Timing in Slave Mode (Alternate Phase of SPICLK)

5.9.6 Programming Examples

Example 1, SPI controller is set as a master to access an off-chip slave device with following specifications:

- Data bit is latched on positive edge of serial clock
- Data bit is driven on negative edge of serial clock
- Data is transferred from MSB first
- SPICLK is idle at low state
- Only one byte of data to be transmitted/received in a transaction
- Use the first SPI slave select pin to connect with an off-chip slave device. Slave select signal is active low

The operation flow is as follows:

- 1) Set the DIVIDER (SPI_DIVIDER [15:0]) register to determine the output frequency of serial clock.
- 2) Write the SPI_SSR register a proper value for the related settings of Master mode
 1. Disable the Automatic Slave Select bit AUTOSS(SPI_SSR[3] = 0)
Select low level trigger output of slave select signal in the Slave Select Active Level bit SS_LVL (SPI_SSR[2] = 0)
 2. Select slave select signal to be output active at the I/O pin by setting the Slave Select Register bits SSR[0] (SPI_SSR[0]) to active the off-chip slave devices
- 3) Write the related settings into the SPI_CNTRL register to control this SPI master actions
 1. Set this SPI controller as master device in SLAVE bit (SPI_CNTRL[18] = 0)
 2. Force the serial clock idle state at low in CLKP bit (SPI_CNTRL[11] = 0)

3. Select data transmitted at negative edge of serial clock in TX_NEG bit (SPI_CNTRL[2] = 1)
4. Select data latched at positive edge of serial clock in RX_NEG bit (SPI_CNTRL[1] = 0)
5. Set the bit length of word transfer as 8-bit in TX_BIT_LEN bit field (SPI_CNTRL[7:3] = 0x08)
6. Set only one time of word transfer in TX_NUM (SPI_CNTRL[9:8] = 0x0)
7. Set MSB transfer first in MSB bit (SPI_CNTRL[10] = 0), and don't care the SP_CYCLE bit field (SPI_CNTRL[15:12]) due to it's not in Burst mode in this case
- 4) If this SPI master will transmits (writes) one byte data to the off-chip slave device, write the byte data that will be transmitted into the TX0[7:0] (SPI_TX0[7:0]) register.
- 5) If this SPI master just only receives (reads) one byte data from the off-chip slave device, you don't need to care what data will be transmitted and just write 0xFF into the SPI_TX0[7:0] register.
- 6) Enable the GO_BUSY bit (SPI_CNTRL [0] = 1) to start the data transfer at the SPI interface.
- 7) Waiting for SPI interrupt occurred (if the Interrupt Enable IE bit is set) or just polling the GO_BUSY bit till it is cleared to 0 by hardware automatically.
- 8) Read out the received one byte data from RX0 [7:0] (SPI_RX0[7:0]) register.
- 9) Go to 4) to continue another data transfer or set SSR [0] to 0 to inactivate the off-chip slave devices.

Example 2, The SPI controller is set as a slave device and connects with an off-chip master device. The off-chip master device communicates with the on-chip SPI slave controller through the SPI interface with the following specifications:

- Data bit is latched on positive edge of serial clock
- Data bit is driven on negative edge of serial clock
- Data is transferred from LSB first
- SPICLK is idle at high state
- Only one byte of data to be transmitted/received in a transaction
- Slave select signal is high level trigger

The operation flow is as follows:

- 1) Write the SPI_SSR register a proper value for the related settings of Slave mode

Select high level and level trigger for the input of slave select signal by setting the Slave Select Active Level bit SS_LVL (SPI_SSR[2] = 1) and the Slave Select Level Trigger bit SS_LTRIG (SPI_SSR[4] = 1).
- 2) Write the related settings into the SPI_CNTRL register to control this SPI slave actions
 1. Set this SPI controller as slave device in SLAVE bit (SPI_CNTRL[18] = 1)
 2. Select the serial clock idle state at high in CLKP bit (SPI_CNTRL[11] = 1)
 3. Select data transmitted at negative edge of serial clock in TX_NEG bit (SPI_CNTRL[2] = 1)



4. Select data latched at positive edge of serial clock in RX_NEG bit (SPI_CNTRL[1] = 0)
 5. Set the bit length of word transfer as 8-bit in TX_BIT_LEN bit field (SPI_CNTRL[7:3] = 0x08)
 6. Set only one time of word transfer in TX_NUM (SPI_CNTRL[9:8] = 0x0)
 7. Set LSB transfer first in LSB bit (SPI_CNTRL[10] = 1), and don't care the SP_CYCLE bit field (SPI_CNTRL[15:12]) due to not Burst mode in this case.
- 3) If this SPI slave will transmits (be read) one byte data to the off-chip master device, write the byte data that will be transmitted into the TX0 [7:0] (SPI_TX0[7:0]) register.
 - 4) If this SPI slave just only receives (be written) one byte data from the off-chip master device, you don't care what data will be transmitted and just write 0xFF into the SPI_TX0[7:0] register.
 - 5) Enable the GO_BUSY bit (SPI_CNTRL[0] = 1) to wait for the slave select trigger input and serial clock input from the off-chip master device to start the data transfer at the SPI interface.
 - 6) Waiting for SPI interrupt occurred (if the Interrupt Enable IE bit is set), or just polling the GO_BUSY bit till it is cleared to 0 by hardware automatically.
 - 7) Read out the received one byte data from RX[7:0] (SPI_RX0[7:0]) register.
- Go to 3) to continue another data transfer or disable the GO_BUSY bit to stop data transfer.



5.9.7 Register Map

R: read only, W: write only, R/W: both read and write

Register	Offset	R/W	Description	Reset Value
SPI Base Address				
SPI0_BA = 0x4003_0000				
SPI1_BA = 0x4003_4000				
SPI2_BA = 0x4013_0000				
SPI3_BA = 0x4013_4000				
SPI_CNTRL n=0,1..3	SPIn_BA+0x00	R/W	Control and Status Register	0x0500_0004
SPI_DIVIDER n=0,1..3	SPIn_BA+0x04	R/W	Clock Divider Register (Master Only)	0x0000_0000
SPI_SSR n=0,1..3	SPIn_BA+0x08	R/W	Slave Select Register	0x0000_0000
SPI_RX0 n=0,1..3	SPIn_BA+0x10	R	Data Receive Register 0	0x0000_0000
SPI_RX1 n=0,1..3	SPIn_BA+0x14	R	Data Receive Register 1	0x0000_0000
SPI_TX0 n=0,1..3	SPIn_BA+0x20	W	Data Transmit Register 0	0x0000_0000
SPI_TX1 n=0,1..3	SPIn_BA+0x24	W	Data Transmit Register 1	0x0000_0000
SPI_VARCLK n=0,1..3	SPIn_BA+0x34	R/W	Variable Clock Pattern Register	0x007F_FF87
SPI_DMA n=0,1..3	SPIn_BA+0x38	R/W	SPI DMA Mode Control Register	0x0000_0000
SPI_CNTRL2 n=0,1..3	SPIn_BA+0x3C	R/W	Control and Status Register 2	0x0000_0000

Note: When software programs CNTRL, the GO_BUSY bit should be written last.



5.9.8 Register Description

SPI Control and Status Register (SPI_CNTRL)

Register	Offset	R/W	Description	Reset Value
SPI_CNTRL n=0,1..3	SPIn_BA+0x00	R/W	Control and Status Register	0x0500_0004

31	30	29	28	27	26	25	24
Reserved							
23	22	21	20	19	18	17	16
VARCLK_EN	TWOB	Reserved	REORDER		SLAVE	IE	IF
15	14	13	12	11	10	9	8
SP_CYCLE				CLKP	LSB	TX_NUM	
7	6	5	4	3	2	1	0
TX_BIT_LEN					TX_NEG	RX_NEG	GO_BUSY

Bits	Description
[31:24]	Reserved Reserved
[23]	VARCLK_EN Variable Clock Enable (Master Only) 1 = The serial clock output frequency is variable. The output frequency is decided by the value of VARCLK, DIVIDER, and DIVIDER2. 0 = The serial clock output frequency is fixed and decided only by the value of DIVIDER. Note: When this VARCLK_EN bit is enabled, the setting of TX_BIT_LEN must be programmed as 0x10 (16-bit mode)
[22]	TWOB Two Bits Transfer Mode Active 1 = Two-bit transfer mode Enabled. 0 = Two-bit transfer mode Disabled. Note1: When TWOB is enabled, the serial transmitted 2-bit data output are from SPI_TX1/0, and the received 2-bit data input are put in SPI_RX1/0. Note2: When TWOB is enabled, the setting of TX_NUM must be programmed as 0x00
[21]	Reserved Reserved
[20:19]	REORDER Reorder Mode Selection 00 = Both byte reorder and byte suspend functions Disabled. 01 = Byte reorder function Enabled and a byte suspend interval (2~17 SPICLK cycles) inserted among each byte. The setting of TX_BIT_LEN must be configured as 0x00. (32 bits/word) 10 = Byte reorder function Enabled, but byte suspend function Disabled. 11 = byte reorder function Disabled, but a suspend interval (2~17 SPICLK cycles)



		<p>inserted among each byte. The setting of TX_BIT_LEN must be configured as 0x00. (32 bits/word)</p> <p>Note:</p> <ol style="list-style-type: none"> 1. Byte reorder function is only available if TX_BIT_LEN is defined as 16, 24, and 32 bits. 2. In Slave mode with level-trigger configuration, if the byte suspend function is enabled, the slave select pin must be kept at active state during the successive four bytes transfer.
[18]	SLAVE	<p>Slave Mode Enable Bit</p> <p>1 = Slave mode 0 = Master mode</p>
[17]	IE	<p>Interrupt Enable</p> <p>1 = SPI Interrupt Enabled 0 = SPI Interrupt Disabled</p>
[16]	IF	<p>Interrupt Flag</p> <p>1 = Transfer is done. 0 = Transfer is not finished yet.</p> <p>Note: This bit will be cleared by writing 1 to itself.</p>
[15:12]	SP_CYCLE	<p>Suspend Interval (Master Only)</p> <p>These four bits provide configurable suspend interval between two successive transmit/receive transaction in a transfer. The suspend interval is from the last falling clock edge of the current transaction to the first rising clock edge of the successive transaction if CLKP = 0. If CLKP = 1, the interval is from the rising clock edge to the falling clock edge. The default value is 0x0. When TX_NUM = 00b, setting this field has no effect on transfer. The desired suspend interval is obtained according to the following equation:</p> <ul style="list-style-type: none"> ■ For byte suspend interval and Burst mode suspend interval: $(SP_CYCLE[3:0] + 2) * \text{period of SPICLK} + 1 \text{ system clock cycle}$ <p>Ex:</p> <p>SP_CYCLE = 0x0 ... 2 SPICLK clock cycle + 1 system clock cycle SP_CYCLE = 0x1 ... 3 SPICLK clock cycle + 1 system clock cycle SP_CYCLE = 0xE ... 16 SPICLK clock cycle + 1 system clock cycle SP_CYCLE = 0xF ... 17 SPICLK clock cycle + 1 system clock cycle</p> <p>If the SPI clock rate equals system clock rate, that is to say, the DIV_ONE feature is enabled, the Burst mode suspend interval period is</p> <p>$(SP_CYCLE[3:0] * 2 + 3.5) * \text{period of system clock}$</p>
[11]	CLKP	<p>Clock Polarity</p> <p>1 = SPICLK idle high 0 = SPICLK idle low</p>
[10]	LSB	<p>LSB First</p> <p>1 = LSB is sent first on the line (bit 0 of SPI_TX0/1), and the first bit received from the line will be put in the LSB position in the RX register (bit 0 of SPI_RX0/1). 0 = MSB is transmitted/received first (which bit in SPI_TX0/1 and SPI_RX0/1 register</p>



		that is depends on the TX_BIT_LEN field).
[9:8]	TX_NUM	<p>Numbers of Transmit/Receive Word</p> <p>This field specifies how many transmit/receive word numbers should be executed in one transfer.</p> <p>00 = Only one transmit/receive word will be executed in one transfer.</p> <p>01 = Two successive transmit/receive words will be executed in one transfer. (Burst mode)</p> <p>10 = Reserved.</p> <p>11 = Reserved.</p> <p>Note: in Slave mode with level-trigger configuration, if TX_NUM is set to 01, the slave select pin must be kept at active state during the successive data transfer.</p>
[7:3]	TX_BIT_LEN	<p>Transmit Bit Length</p> <p>This field specifies how many bits can be transmitted / received in one transaction. The minimum bit length is 8 bits and can up to 32 bits.</p> <p>TX_BIT_LEN = 0x08 ... 8 bits</p> <p>.....</p> <p>TX_BIT_LEN = 0x1F ... 31 bits</p> <p>TX_BIT_LEN = 0x00 ... 32 bits</p>
[2]	TX_NEG	<p>Transmit At Negative Edge</p> <p>1 = The transmitted data output signal is changed at the falling edge of SPICLK</p> <p>0 = The transmitted data output signal is changed at the rising edge of SPICLK</p>
[1]	RX_NEG	<p>Receive At Negative Edge</p> <p>1 = The received data input signal is latched at the falling edge of SPICLK</p> <p>0 = The received data input signal is latched at the rising edge of SPICLK</p>
[0]	GO_BUSY	<p>Go and Busy Status</p> <p>1 = In Master mode, writing 1 to this bit to start the SPI data transfer; in Slave mode, writing 1 to this bit indicates that the slave is ready to communicate with a master.</p> <p>0 = Stop data transfer if SPI is transferring.</p> <p>During the data transfer, this bit keeps the value of 1. As the transfer is finished, this bit will be cleared automatically.</p> <p>Note: All registers should be set before writing 1 to this GO_BUSY bit.</p>



SPI Divider Register (SPI_DIVIDER)

Register	Offset	R/W	Description	Reset Value
SPI_DIVIDER n=0,1..3	SPIIn_BA+0x04	R/W	Clock Divider Register (Master Only)	0x0000_0000

31	30	29	28	27	26	25	24
DIVIDER2[15:8]							
23	22	21	20	19	18	17	16
DIVIDER2[7:0]							
15	14	13	12	11	10	9	8
DIVIDER[15:8]							
7	6	5	4	3	2	1	0
DIVIDER[7:0]							

Bits	Description	Description
[31:16]	DIVIDER2	<p>Clock Divider 2 (Master Only)</p> <p>The value in this field is the 2nd frequency divider for generating the serial clock on the output SPICLK. The desired frequency is obtained according to the following equation:</p> $f_{sclk} = \frac{f_{pclk}}{(DIVIDER2 + 1) * 2}$ <p>If VARCLK_EN is cleared to 0, this setting is unmeaning.</p>
[15:0]	DIVIDER	<p>Clock Divider 1 (master only)</p> <p>The value in this field is the frequency divider for generating the serial clock on the output SPICLK. The desired frequency is obtained according to the following equation:</p> $f_{sclk} = \frac{f_{pclk}}{(DIVIDER + 1) * 2}$ <p>In Slave mode, the period of SPI clock driven by a master shall equal or over 5 times the period of PCLK. In other words, the maximum frequency of SPI clock is the fifth of the frequency of slave's PCLK.</p>



SPI Slave Select Register (SPI SSR)

Register	Offset	R/W	Description	Reset Value
SPI_SSR N=0,1..3	SPIn_BA+0x08	R/W	Slave Select Register	0x0000_0000

31	30	29	28	27	26	25	24
Reserved							
23	22	21	20	19	18	17	16
Reserved							
15	14	13	12	11	10	9	8
Reserved							
7	6	5	4	3	2	1	0
Reserved		LTRIG_FLAG	SS_LTRIG	AUTOSS	SS_LVL	SSR	

Bits	Description	
[31:6]	Reserved	Reserved
[5]	LTRIG_FLAG	<p>Level Trigger Accomplish Flag</p> <p>When the SS_LTRIG bit is set in Slave mode, this bit can be read to indicate the received bit number is met the requirement or not.</p> <p>1 = The transaction number and the transferred bit length met the specified requirements which defined in TX_NUM and TX_BIT_LEN.</p> <p>0 = The transaction number or the transferred bit length of one transaction doesn't meet the specified requirements.</p> <p>Note: This bit is READ only</p>
[4]	SS_LTRIG	<p>Slave Select Level Trigger Enable Bit (Slave Only)</p> <p>1 = The slave select signal will be level-trigger. It depends on SS_LVL to decide the signal is active low or active high.</p> <p>0 = The input slave select signal is edge-trigger. This is the default value. It depends on SS_LVL to decide the signal is active at falling-edge or rising-edge</p>
[3]	AUTOSS	<p>Automatic Slave Select Enable Bit (Master only)</p> <p>1 = If this bit is set, SPISSx0/1 signals will be generated automatically. It means that device/slave select signal, which is set in SSR[1:0], will be asserted by the SPI controller when transmit/receive is started by setting GO_BUSY, and will be de-asserted after each transmit/receive is finished.</p> <p>0 = If this bit is cleared, slave select signals will be asserted/de-asserted by setting /clearing related bits in SSR[1:0].</p>
[2]	SS_LVL	<p>Slave Select Active Level</p> <p>It defines the active status of slave select signal (SPISSx0/1).</p> <p>1 = The slave select signal SPISSx0/1 is active at high-level/rising-edge.</p> <p>0 = The slave select signal SPISSx0/1 is active at low-level/falling-edge.</p>



[1:0]	SSR	<p>Slave Select Control Bits (Master Only)</p> <p>If AUTOSS bit is cleared, writing 1 to any bit location of this field sets the proper SPISSx0/1 line to an active state and writing 0 sets the line back to inactive state.</p> <p>If AUTOSS bit is set, writing 0 to any bit location of this field will keep the corresponding SPISSx0/1 line at inactive state; writing 1 to any bit location of this field will select the corresponding SPISSx0/1 line to be automatically driven to active state for the duration of the transmit/receive, and will be driven to inactive state for the rest of the time. The active state of SPISSx0/1 is specified in SS_LVL.</p> <p>Note: SPISSx0 is also defined as slave select input in Slave mode.</p>
-------	------------	---



SPI Data Receive Register (SPI_RX)

Register	Offset	R/W	Description	Reset Value
SPI_RX0 n=0,1..3	SPIn_BA+0x10	R	Data Receive Register 0	0x0000_0000
SPI_RX1 n=0,1..3	SPIn_BA+0x14	R	Data Receive Register 1	0x0000_0000

31	30	29	28	27	26	25	24
RX[31:24]							
23	22	21	20	19	18	17	16
RX[23:16]							
15	14	13	12	11	10	9	8
RX[15:8]							
7	6	5	4	3	2	1	0
RX[7:0]							

Bits	Description
[31:0]	<p>Data Receive Register</p> <p>The Data Receive Registers hold the value of received data of the last executed transfer. Valid bits depend on the transmit bit length field in the SPI_CNTRL register.</p> <p>For example, if TX_BIT_LEN is set to 0x08 and TX_NUM is set to 0x0, bit RX0[7:0] holds the received data. The values of the other bits are unknown.</p> <p>Note: These bits are read only.</p>



SPI Data Transmit Register (SPI_TX)

Register	Offset	R/W	Description	Reset Value
SPI_TX0 n=0,1..3	SPIn_BA+0x20	W	Data Transmit Register 0	0x0000_0000
SPI_TX1 n=0,1..3	SPIn_BA+0x24	W	Data Transmit Register 1	0x0000_0000

31	30	29	28	27	26	25	24
TX[31:24]							
23	22	21	20	19	18	17	16
TX[23:16]							
15	14	13	12	11	10	9	8
TX[15:8]							
7	6	5	4	3	2	1	0
TX[7:0]							

Bits	Description
[31:0]	<p>Data Transmit Register</p> <p>The Data Transmit Registers hold the data to be transmitted in the next transfer. Valid bits depend on the transmit bit length field in the CNTRL register.</p> <p>For example, if TX_BIT_LEN is set to 0x08 and the TX_NUM is set to 0x0, the bit TX0[7:0] will be transmitted in next transfer. If TX_BIT_LEN is set to 0x00 and TX_NUM is set to 0x1, the SPI controller will perform two 32-bit transmit/receive successive using the same setting. The transmission sequence is TX0[31:0] first and then TX1[31:0].</p>



SPI Variable Clock Pattern Register (SPI_VARCLK)

Register	Offset	R/W	Description	Reset Value
SPI_VARCLK n=0,1..3	SPIn_BA+0x34	R/W	Variable Clock Pattern Register	0x007F_FF87

31	30	29	28	27	26	25	24
VARCLK[31:24]							
23	22	21	20	19	18	17	16
VARCLK[23:16]							
15	14	13	12	11	10	9	8
VARCLK[15:8]							
7	6	5	4	3	2	1	0
VARCLK[7:0]							

Bits	Description	
[31:0]	VARCLK	<p>Variable Clock Pattern</p> <p>The value in this field is the frequency patterns of the SPI clock. If the bit pattern of VARCLK is '0', the output frequency of SPICLK is according the value of DIVIDER. If the bit patterns of VARCLK are '1', the output frequency of SPICLK is according the value of DIVIDER2. Refer to register SPI_DIVIDER.</p> <p>Refer to the Variable Serial Clock Frequency paragraph for more detailed description.</p>



DMA Control Register (DMACTL)

Register	Offset	R/W	Description	Reset Value
SPI_DMA n=0,1..3	SPIIn_BA+0x38	R/W	SPI DMA Mode Control Register	0x0000_0000

31	30	29	28	27	26	25	24
Reserved							
23	22	21	20	19	18	17	16
Reserved							
15	14	13	12	11	10	9	8
Reserved							
7	6	5	4	3	2	1	0
Reserved						RX_DMA_GO	TX_DMA_GO

Bits	Description	
[31:2]	Reserved	Reserved
[1]	RX_DMA_GO	<p>Receive DMA Start</p> <p>Set this bit to 1 will start the receive PDMA process. SPI controller will issue request to PDMA controller automatically.</p> <p>Hardware will clear this bit to 0 automatically after PDMA transfer done.</p>
[0]	TX_DMA_GO	<p>Transmit DMA Start</p> <p>Set this bit to 1 will start the transmit PDMA process. SPI controller will issue request to PDMA controller automatically.</p> <p>If using PDMA mode to transfer data, remember not to set GO_BUSY bit of SPI_CNTRL register. The DMA controller inside SPI controller will set it automatically whenever necessary.</p> <p>Hardware will clear this bit to 0 automatically after PDMA transfer done.</p> <p>Note: In DMA mode, the Burst mode is not supported.</p>



SPI Control and Status Register 2 (SPI_CNTRL2)

Register	Offset	R/W	Description	Reset Value
SPI_CNTRL2 n=0,1..3	SPIn_BA+0x3C	R/W	Control and Status Register 2	0x0000_0000

31	30	29	28	27	26	25	24
Reserved							
23	22	21	20	19	18	17	16
Reserved							
15	14	13	12	11	10	9	8
Reserved				SLV_START_INTSTS	SSTA_INT EN	SLV_ABORT	NOSLVSEL
7	6	5	4	3	2	1	0
Reserved							DIV_ONE

Bits	Description
[31:12]	Reserved
[11]	<p>SLV_START_INTSTS</p> <p>Slave 3-Wire Mode Start Interrupt Status</p> <p>It is used to dedicate that the transfer has start in Slave mode with no slave select.</p> <p>1 = It indicates that the transfer start in Slave mode with no slave select. It is auto clear by transfer done or writing one clear.</p> <p>0 = It indicates that the slave start transfer no active.</p>
[10]	<p>SSTA_INTEN</p> <p>Slave 3-Wire Mode Start Interrupt Enable</p> <p>It is used to enable interrupt when the transfer has start in Slave mode with no slave select. If there is no transfer done interrupt over the time period which is defined by user after the transfer start, the user can set the SLV_ABORT bit to force the transfer done.</p> <p>1 = Transaction start interrupt Enabled. It is clear by the current transfer done or the SLV_START_INTSTS bit be clear (write one clear).</p> <p>0 = Transfer start interrupt Disabled.</p>
[9]	<p>SLV_ABORT</p> <p>Slave 3-Wire Mode Abort Control Bit</p> <p>In normal operation, there is interrupt event when the received data meet the required bits which define in TX_BIT_LEN and TX_NUM.</p> <p>If the received bits are less than the requirement and there is no more serial clock input over the one transfer time in Slave mode with no slave select, the user can set this bit to force the current transfer done and then the user can get a transfer done interrupt event.</p> <p>Note: It is auto cleared to 0 by hardware when the abort event is active.</p>
[8]	<p>NOSLVSEL</p> <p>Slave 3-Wire Mode Enable Bit</p>



		<p>This is used to ignore the slave select signal in Slave mode. The SPI controller can work on 3 wire interface including SPICLK, SPI_MISO, and SPI_MOSI when it is set as a slave device.</p> <p>0 = The controller is 4-wire bi-direction interface.</p> <p>1 = The controller is 3-wire bi-direction interface in Slave mode. When this bit is set as 1, the controller start to transmit/receive data after the GO_BUSY bit active and the serial clock input.</p> <p>Note: In no slave select signal mode, the SS_LTRIG, SPI_SSR[4], shall be set as 1.</p>
[7:1]	Reserved	Reserved
[0]	DIV_ONE	<p>SPI Clock Divider Control</p> <p>0 = The SPI clock rate is determined by the setting of SPI_DIVIDER register.</p> <p>1 = DIV_ONE feature Enabled. The SPI clock rate equals the system clock rate.</p> <p>Note:</p> <ol style="list-style-type: none"> When this bit is set as 1, both the REORDER field and the VARCLK_EN field must be configured as 0. In other words, the byte-reorder function, byte suspend function and variable clock function must be disabled. When this bit is set as 1, the TX_BIT_LEN cannot be set as 1.



5.10 Timer Controller (TMR)

5.10.1 Overview

The timer controller includes four 32-bit timers, TIMER0~TIMER3, which allows user to easily implement a timer control for applications. The timer can perform functions like frequency measurement, event counting, interval measurement, clock generation, delay timing, and so on. The timer can generate an interrupt signal upon timeout, or provide the current value during operation.

5.10.2 Features

- 4 sets of 32-bit timers with 24-bit up-timer and one 8-bit pre-scale counter
- Independent clock source for each timer
- Provides one-shot, periodic, toggle and continuous counting operation modes
- Time out period = (Period of timer clock input) * (8-bit pre-scale counter + 1) * (24-bit TCMP)
- Maximum counting cycle time = $(1 / T \text{ MHz}) * (2^8) * (2^{24})$, where T is the period of timer clock
- 24-bit timer value is readable through TDR (Timer Data Register)
- Supports event counting function to count the event from external pin
- Supports input capture function to capture or reset counter value



5.10.3 Block Diagram

Each channel is equipped with an 8-bit pre-scale counter, a 24-bit up-timer, a 24-bit compare register and an interrupt request signal. Refer to Figure 5-63 for the timer controller block diagram. There are four options of clock sources for each channel. Figure 5-64 illustrates the clock source control function. Software can program the 8-bit pre-scale counter to decide the clock period to 24-bit up timer.

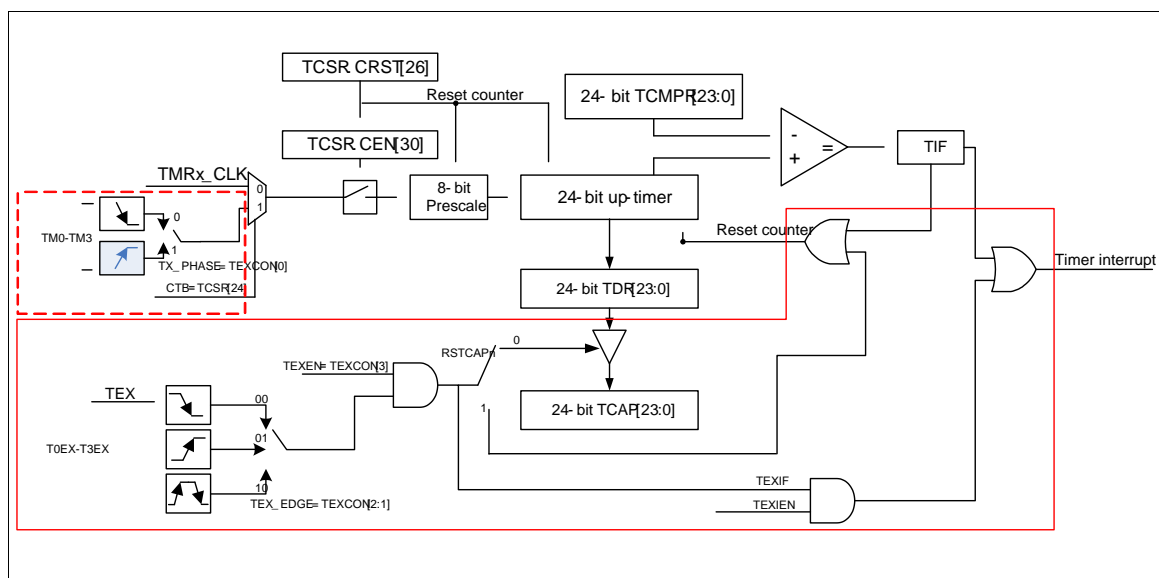

Figure 5-63 Timer Controller Block Diagram

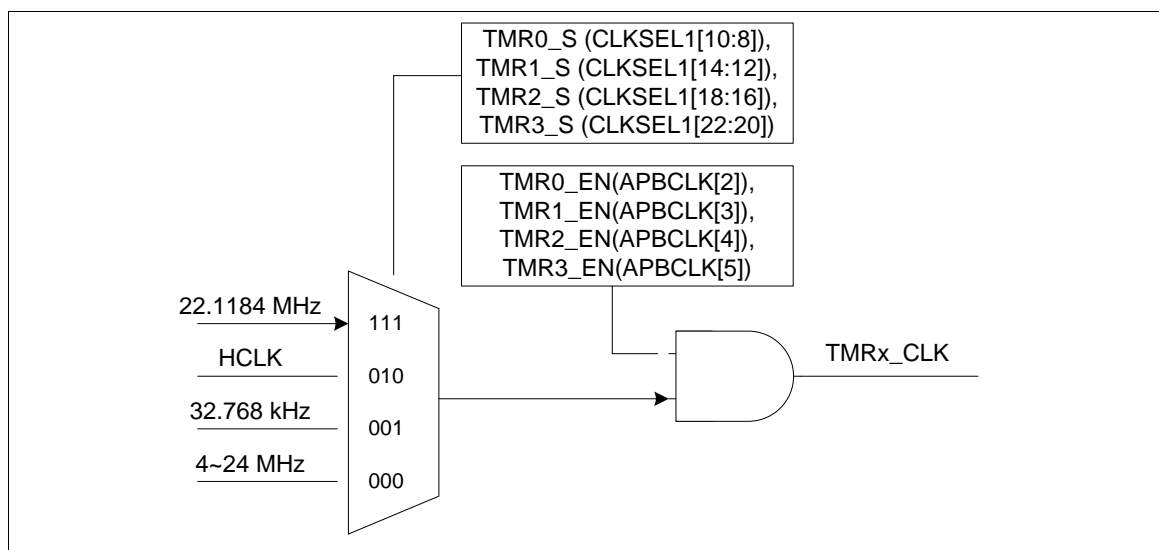

Figure 5-64 Clock Source of Timer Controller



5.10.4 Functional Description

Timer controller provides One-shot, Period, Toggle and Continuous Counting Operation modes. It also provides the event counting function to count the event from external pin and input capture function to capture or reset timer counter value. Each operating function mode is shown as follows:

5.10.4.1 One-shot Mode

If timer is operated in One-shot mode and CEN (TCSR[30] timer enable bit) is set to 1, the timer counter starts up counting. Once the timer counter value reaches timer compare register (TCMPR) value, if IE (TCSR[29] interrupt enable bit) is set to 1, then the timer interrupt flag is set and the interrupt signal is generated and sent to NVIC to inform CPU. It indicates that the timer counting overflow happens. If IE (TCSR[29] interrupt enable bit) is set to 0, no interrupt signal is generated. In this operating mode, once the timer counter value reaches timer compare register (TCMPR) value, the timer counter value goes back to counting initial value and CEN (timer enable bit) is cleared to 0 by timer controller. Timer counting operation stops, once the timer counter value reaches timer compare register (TCMPR) value. That is to say, timer operates timer counting and compares with TCMPR value function only one time after programming the timer compare register (TCMPR) value and CEN (timer enable bit) is set to 1. So, this operating mode is called One-Shot mode.

5.10.4.2 Periodic Mode

If timer is operated in Period mode and CEN (TCSR[30] timer enable bit) is set to 1, the timer counter starts up counting. Once the timer counter value reaches timer compare register (TCMPR) value, if IE (TCSR[29] interrupt enable bit) is set to 1, then the timer interrupt flag is set and the interrupt signal is generated and sent to NVIC to inform CPU. It indicates that the timer counting overflow happens. If IE (TCSR[29] interrupt enable bit) is set to 0, no interrupt signal is generated. In this operating mode, once the timer counter value reaches timer compare register (TCMPR) value, the timer counter value goes back to counting initial value and CEN is kept at 1 (counting enable continuously). The timer counter operates up counting again. If the interrupt flag is cleared by software, once the timer counter value reaches timer compare register (TCMPR) value and IE (interrupt enable bit) is set to 1'b1, then the timer interrupt flag is set and the interrupt signal is generated and sent to NVIC to inform CPU again. That is to say, timer operates timer counting and compares with TCMPR value function periodically. The timer counting operation does not stop until the CEN is set to 0. The interrupt signal is also generated periodically. So, this operating mode is called Periodic mode.

5.10.4.3 Toggle Mode

If timer is operated in Toggle mode and CEN (TCSR[30] timer enable bit) is set to 1, the timer counter starts up counting. Once the timer counter value reaches timer compare register (TCMPR) value, if IE (TCSR[29] interrupt enable bit) is set to 1, then the timer interrupt flag is set and the interrupt signal is generated and sent to NVIC to inform CPU. It indicates that the timer counting overflow happens. The associated toggle output (tout) signal is set to 1. In this operating mode, once the timer counter value reaches timer compare register (TCMPR) value, the timer counter value goes back to counting initial value and CEN is kept at 1 (counting enable continuously). The timer counter operates up counting again. If the interrupt flag is cleared by software, once the timer counter value reaches timer compare register (TCMPR) value and IE (interrupt enable bit) is set to 1, then the timer interrupt flag is set and the interrupt signal is generated and sent to NVIC to inform CPU again. The associated toggle output (tout) signal is set to 0. The timer counting operation does not stop until the CEN is set to 0. Thus, the toggle output (tout) signal is changing back and forth with 50% duty cycle. This operating mode is called Toggle mode.

5.10.4.4 Continuous Counting Mode

If the timer is operated in Continuous Counting mode and CEN (TCSR[30] timer enable bit) is set to 1, the associated interrupt signal is generated depending on $TDR = TCMPR$ if IE (TCSR[29] interrupt enable bit) is enabled. User can change different TCMPR value immediately without disabling timer counting and restarting timer counting. For example, TCMPR is set as 80, first. (The TCMPR should be less than 2^{24} and be greater than 1). The timer generates the interrupt if IE is enabled and TIF (timer interrupt flag) will set to 1 then the interrupt signal is generated and sent to NVIC to inform CPU when TDR value is equal to 80. But the CEN is kept at 1 (counting enable continuously) and TDR value will not goes back to 0, it continues to count 81, 82, 83, ... to $2^{24} - 1$, 0, 1, 2, 3, ... to $2^{24} - 1$ again and again. Next, if user programs TCMPR as 200 and the TIF is cleared to 0, then timer interrupt occurred and TIF is set to 1, then the interrupt signal is generated and sent to NVIC to inform CPU again when TDR value reaches to 200. At last, user programs TCMPR as 500 and clears TIF to 0 again, then timer interrupt occurred and TIF sets to 1 then the interrupt signal is generated and sent to NVIC to inform CPU when TDR value reaches to 500. From application view, the interrupt is generated depending on TCMPR. In this mode, the timer counting is continuous. Thus, this operation mode is called Continuous Counting mode.

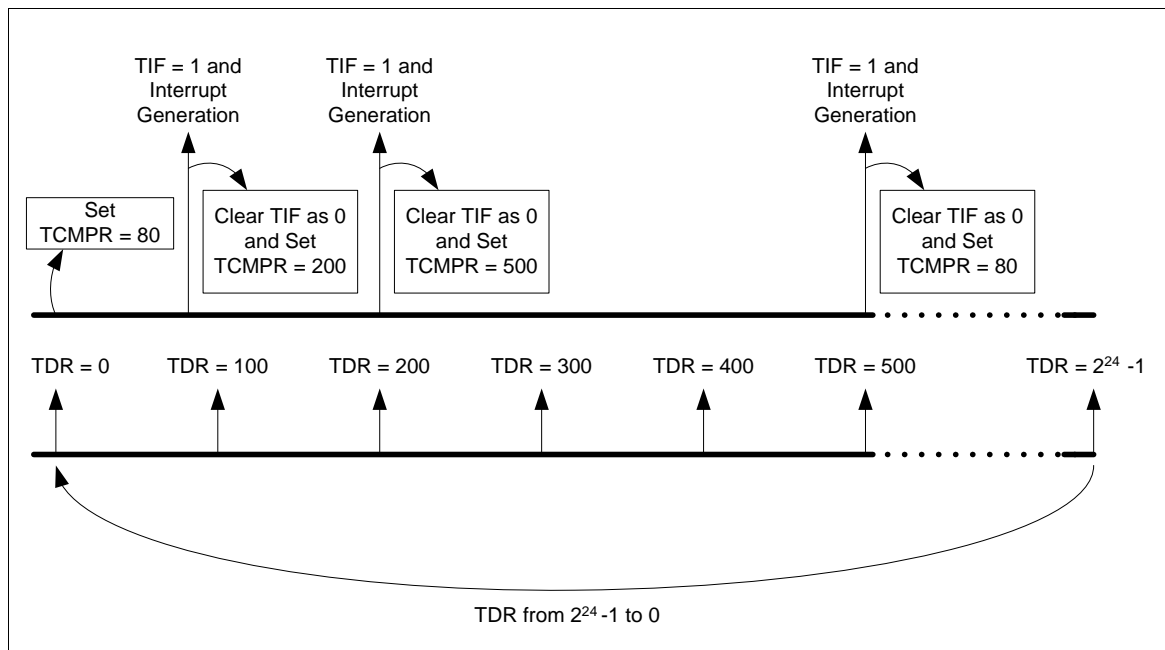

Figure 5-65 Continuous Counting Mode

5.10.4.5 Event Counting Function

An application which can count the event from TM0~TM3 pins is provided. It is called as event counting function. In event counting function, the clock source of timer controller, TMRx_CLK, in Figure 5-65 should be set as HCLK. It provides TM0~TM3 enabled or disabled de-bounce function by TEXCONx[7] and TM0~TM3 falling or rising phase counting setting by TEXCONx[0]. Also, the event count source operating frequency should be less than $1/3$ HCLK frequency if counting de-bounce is disabled or less than $1/8$ HCLK frequency if counting de-bounce is enabled. Otherwise, the returned TDR value is incorrect.



5.10.4.6 *Input Capture Function*

The input capture function is also provided to capture or reset timer counter value. If TEXEN (Timer External Pin Enable) is set to 1 and RSTCAPSEL is set to 0, the timer counter value (TDR) will be captured into TCAP register when TEX (Timer External Pin) pin trigger condition occurred. There are four TEX sources from specified pins, T0EX~T3EX pins. If TEXEN is set to 1 and RSTCAPSEL is set to 1, the TDR will be reset to 0 when TEX pin trigger condition happened. The TEX trigger edge can choose by TEX_EDGE. When TEX trigger occurred, TEXIF (Timer External Interrupt Flag) is set to 1, and if enabled TEXIEN (Timer External Interrupt Enable Bit) to 1, the interrupt signal is generated then sent to NVIC to inform CPU. It also provides T0EX~T3EX enabled or disabled capture de-bounce function by TEXCONx[6]. Also, the TEX source operating frequency should be less than 1/3 HCLK frequency if TEX de-bounce is disabled or less than 1/8 HCLK frequency if TEX de-bounce is enabled.



5.10.5 Register Map

R: read only, W: write only, R/W: both read and write

Register	Offset	R/W	Description	Reset Value
TMR Base Address:				
TMR_BA01 = 0x4001_0000				
TMR_BA23 = 0x4011_0000				
TCSR0	TMR_BA01+0x00	R/W	Timer0 Control and Status Register	0x0000_0005
TCMPR0	TMR_BA01+0x04	R/W	Timer0 Compare Register	0x0000_0000
TISR0	TMR_BA01+0x08	R/W	Timer0 Interrupt Status Register	0x0000_0000
TDR0	TMR_BA01+0x0C	R	Timer0 Data Register	0x0000_0000
TCAP0	TMR_BA01+0x10	R	Timer0 Capture Data Register	0x0000_0000
TEXCON0	TMR_BA01+0x14	R/W	Timer0 External Control Register	0x0000_0000
TEXISR0	TMR_BA01+0x18	R/W	Timer0 External Interrupt Status Register	0x0000_0000
TCSR1	TMR_BA01+0x20	R/W	Timer1 Control and Status Register	0x0000_0005
TCMPR1	TMR_BA01+0x24	R/W	Timer1 Compare Register	0x0000_0000
TISR1	TMR_BA01+0x28	R/W	Timer1 Interrupt Status Register	0x0000_0000
TDR1	TMR_BA01+0x2C	R	Timer1 Data Register	0x0000_0000
TCAP1	TMR_BA01+0x30	R	Timer1 Capture Data Register	0x0000_0000
TEXCON1	TMR_BA01+0x34	R/W	Timer1 External Control Register	0x0000_0000
TEXISR1	TMR_BA01+0x38	R/W	Timer1 External Interrupt Status Register	0x0000_0000
TCSR2	TMR_BA23+0x00	R/W	Timer2 Control and Status Register	0x0000_0005
TCMPR2	TMR_BA23+0x04	R/W	Timer2 Compare Register	0x0000_0000
TISR2	TMR_BA23+0x08	R/W	Timer2 Interrupt Status Register	0x0000_0000
TDR2	TMR_BA23+0x0C	R	Timer2 Data Register	0x0000_0000
TCAP2	TMR_BA23+0x10	R	Timer2 Capture Data Register	0x0000_0000
TEXCON2	TMR_BA23+0x14	R/W	Timer2 External Control Register	0x0000_0000
TEXISR2	TMR_BA23+0x18	R/W	Timer2 External Interrupt Status Register	0x0000_0000
TCSR3	TMR_BA23+0x20	R/W	Timer3 Control and Status Register	0x0000_0005
TCMPR3	TMR_BA23+0x24	R/W	Timer3 Compare Register	0x0000_0000
TISR3	TMR_BA23+0x28	R/W	Timer3 Interrupt Status Register	0x0000_0000



TDR3	TMR_BA23+0x2C	R	Timer3 Data Register	0x0000_0000
TCAP3	TMR_BA23+0x30	R	Timer3 Capture Data Register	0x0000_0000
TEXCON3	TMR_BA23+0x34	R/W	Timer3 External Control Register	0x0000_0000
TEXISR3	TMR_BA23+0x38	R/W	Timer3 External Interrupt Status Register	0x0000_0000



5.10.6 Register Description

Timer Control Register (TCSR)

Register	Offset	R/W	Description	Reset Value
TCSR0	TMR_BA01+0x00	R/W	Timer0 Control and Status Register	0x0000_0005
TCSR1	TMR_BA01+0x20	R/W	Timer1 Control and Status Register	0x0000_0005
TCSR2	TMR_BA23+0x00	R/W	Timer2 Control and Status Register	0x0000_0005
TCSR3	TMR_BA23+0x20	R/W	Timer3 Control and Status Register	0x0000_0005

31	30	29	28	27	26	25	24
DBGACK_TMR	CEN	IE	MODE[1:0]		CRST	CACT	CTB
23	22	21	20	19	18	17	16
Reserved							TDR_EN
15	14	13	12	11	10	9	8
Reserved							
7	6	5	4	3	2	1	0
PRESCALE[7:0]							

Bits	Description
[31]	<p>DBGACK_TMR</p> <p>ICE debug Mode Acknowledge Disable (Write-protection Bit) 0 = ICE debug mode acknowledgement affects TIMER counting. TIMER counter will be held while ICE debug mode acknowledged. 1 = ICE debug mode acknowledgement disabled. TIMER counter will keep going no matter ICE debug mode acknowledged or not.</p>
[30]	<p>CEN</p> <p>Timer Enable Bit 1 = Starts counting 0 = Stops/Suspends counting</p> <p>Note1: In stop status, and then set CEN to 1 will enables the 24-bit up-timer keeps up counting from the last stop counting value. Note2: This bit is auto-cleared by hardware in One-shot mode (MODE [28:27] =00) when the associated timer interrupt is generated (IE [29] =1).</p>
[29]	<p>IE</p> <p>Interrupt Enable Bit 1 = Timer Interrupt Enabled 0 = Timer Interrupt Disabled</p> <p>If timer interrupt is enabled, the timer asserts its interrupt signal when the associated up-timer value is equal to TCMRPR.</p>



[28:27]	MODE	Timer Operating Mode	
		MODE	Timer Operating Mode
		00	The timer is operating at the one-shot mode. The associated interrupt signal is generated once (if IE is enabled) and CEN is automatically cleared by hardware.
		01	The timer is operating at the periodic mode. The associated interrupt signal is generated periodically (if IE is enabled).
		10	The timer is operating in Toggle mode. The interrupt signal is generated periodically (if IE is enabled), and the associated signal (tout) is changing back and forth with 50% duty cycle.
	11	The timer is operating at continuous counting mode. The associated interrupt signal is generated when TDR = TCMPR (if IE is enabled). However, the 24-bit up-timer counts continuously. Please refer 5.10.4.4 for detail description about continuous counting mode operation.	
[26]	CRST	Timer Reset Bit Setting this bit will reset the 24-bit up-timer, 8-bit pre-scale counter and also force CEN to 0. 0 = No effect 1 = Reset Timer's 8-bit pre-scale counter, internal 24-bit up-timer and CEN bit	
[25]	CACT	Timer Active Status Bit (Read Only) This bit indicates the up-timer status. 0 = Timer is not active 1 = Timer is active	
[24]	CTB	Counter Mode Enable Bit This bit is the counter mode enable bit. When Timer is used as an event counter, this bit should be set to 1 and Timer will work as an event counter. The counter detect phase can be selected as rising/falling edge of external pin by TX_PHASE field. 1 = Counter mode Enabled 0 = Counter mode Disabled	
[23:17]	Reserved	Reserved	
[16]	TDR_EN	Data Load Enable When TDR_EN is set, TDR (Timer Data Register) will be updated continuously with the 24-bit up-timer value as the timer is counting. 1 = Timer Data Register update Enabled 0 = Timer Data Register update Disabled	
[15:8]	Reserved	Reserved	
[7:0]	PRESCALE	Pre-scale Counter Clock input is divided by PRESCALE+1 before it is fed to the counter. If PRESCALE = 0, then there is no scaling.	



Timer Compare Register (TCMPR)

Register	Offset	R/W	Description	Reset Value
TCMPR0	TMR_BA01+0x04	R/W	Timer0 Compare Register	0x0000_0000
TCMPR1	TMR_BA01+0x24	R/W	Timer1 Compare Register	0x0000_0000
TCMPR2	TMR_BA23+0x04	R/W	Timer2 Compare Register	0x0000_0000
TCMPR3	TMR_BA23+0x24	R/W	Timer3 Compare Register	0x0000_0000

31	30	29	28	27	26	25	24
Reserved							
23	22	21	20	19	18	17	16
TCMP [23:16]							
15	14	13	12	11	10	9	8
TCMP [15:8]							
7	6	5	4	3	2	1	0
TCMP [7:0]							

Bits	Description
[31:24]	Reserved
[23:0]	<p>Timer Compared Value</p> <p>TCMP is a 24-bit compared register. When the internal 24-bit up-timer counts and its value is equal to TCMP value, a Timer Interrupt is requested if the timer interrupt is enabled with TCSR.IE[29]=1. The TCMP value defines the timer counting cycle time.</p> <p>Time out period = (Period of timer clock input) * (8-bit PRESCALE + 1) * (24-bit TCMP)</p> <p>Note1: Never write 0x0 or 0x1 in TCMP, or the core will run into unknown state.</p> <p>Note2: When timer is operating in Continuous Counting mode, the 24-bit up-timer will count continuously if software writes a new value into TCMP. If timer is operating at other modes, the 24-bit up-timer will restart counting and using newest TCMP value to be the compared value if software writes a new value into TCMP.</p>



Timer Interrupt Status Register (TISR)

Register	Offset	R/W	Description	Reset Value
TISR0	TMR_BA01+0x08	R/W	Timer0 Interrupt Status Register	0x0000_0000
TISR1	TMR_BA01+0x28	R/W	Timer1 Interrupt Status Register	0x0000_0000
TISR2	TMR_BA23+0x08	R/W	Timer2 Interrupt Status Register	0x0000_0000
TISR3	TMR_BA23+0x28	R/W	Timer3 Interrupt Status Register	0x0000_0000

31	30	29	28	27	26	25	24
Reserved							
23	22	21	20	19	18	17	16
Reserved							
15	14	13	12	11	10	9	8
Reserved							
7	6	5	4	3	2	1	0
Reserved							TIF

Bits	Description	
[31:1]	Reserved	Reserved
[0]	TIF	<p>Timer Interrupt Flag</p> <p>This bit indicates the interrupt status of Timer.</p> <p>TIF bit is set by hardware when the up counting value of internal 24-bit up-timer matches the timer compared value (TCMP). It is cleared by writing 1 to this bit.</p>



Timer Data Register (TDR)

Register	Offset	R/W	Description	Reset Value
TDR0	TMR_BA01+0x0C	R	Timer0 Data Register	0x0000_0000
TDR1	TMR_BA01+0x2C	R	Timer1 Data Register	0x0000_0000
TDR2	TMR_BA23+0x0C	R	Timer2 Data Register	0x0000_0000
TDR3	TMR_BA23+0x2C	R	Timer3 Data Register	0x0000_0000

31	30	29	28	27	26	25	24
Reserved							
23	22	21	20	19	18	17	16
TDR[23:16]							
15	14	13	12	11	10	9	8
TDR[15:8]							
7	6	5	4	3	2	1	0
TDR[7:0]							

Bits	Description	
[31:24]	Reserved	Reserved
[23:0]	TDR	<p>Timer Data Register</p> <p>1. CTB (TCSR[24]) = 0 : TDR is 24- bits up timer value. User can read TDR for getting current 24- bits up timer value if TCSR[24] = is set to 0</p> <p>2. CTB (TCSR[24]) = 1 : TDR is 24- bits up event counter value. User can read TDR for getting current 24- bits up event counter value if TCSR[24] is 1</p>



Timer Capture Data Register (TCAP)

Register	Offset	R/W	Description	Reset Value
TCAP0	TMR_BA01+0x10	R	Timer0 Capture Data Register	0x0000_0000
TCAP1	TMR_BA01+0x30	R	Timer1 Capture Data Register	0x0000_0000
TCAP2	TMR_BA23+0x10	R	Timer2 Capture Data Register	0x0000_0000
TCAP3	TMR_BA23+0x30	R	Timer3 Capture Data Register	0x0000_0000

31	30	29	28	27	26	25	24
Reserved							
23	22	21	20	19	18	17	16
TCAP[23:16]							
15	14	13	12	11	10	9	8
TCAP[15:8]							
7	6	5	4	3	2	1	0
TCAP[7:0]							

Bits	Description	
[31:24]	Reserved	Reserved
[23:0]	TCAP	Timer Capture Data Register When TEXEN (TEXCON[3]) is set, RSTCAPSEL (TTXCON[4]) is 0, and the transition on the TEX pins associated TEX_EDGE (TEXCON[2:1]) setting is occurred, the internal 24-bit up-timer value will be loaded into TCAP. User can read this register for the counter value.



Timer External Control Register (TEXCON)

Register	Offset	R/W	Description	Reset Value
TEXCON0	TMR_BA01+0x14	R/W	Timer0 External Control Register	0x0000_0000
TEXCON1	TMR_BA01+0x34	R/W	Timer1 External Control Register	0x0000_0000
TEXCON2	TMR_BA23+0x14	R/W	Timer2 External Control Register	0x0000_0000
TEXCON3	TMR_BA23+0x34	R/W	Timer3 External Control Register	0x0000_0000

31	30	29	28	27	26	25	24
Reserved							
23	22	21	20	19	18	17	16
Reserved							
15	14	13	12	11	10	9	8
Reserved							
7	6	5	4	3	2	1	0
TCDB	TEXDB	TEXIEN	RSTCAPSEL	TEXEN	TEX_EDGE		TX_PHASE

Bits	Description	
[31:8]	Reserved	Reserved
[7]	TCDB	<p>Timer Counter Pin De-bounce Enable</p> <p>1 = De-bounce Enabled 0 = De-bounce Disabled</p> <p>If this bit is enabled, the edge of TMO~TM3 pin is detected with de-bounce circuit.</p>
[6]	TEXDB	<p>Timer External Capture Pin De-bounce Enable</p> <p>1 = De-bounce Enabled 0 = Disabled De-bounce</p> <p>If this bit is enabled, the edge of T0EX~T3EX pin is detected with de-bounce circuit.</p>
[5]	TEXIEN	<p>Timer External Interrupt Enable</p> <p>1 = Timer External Interrupt Enabled 0 = Timer External Interrupt Disabled</p> <p>If timer external interrupt is enabled, the timer asserts its external interrupt signal and sent to NVIC to inform CPU when the transition on the TEX pins associated with TEX_EDGE(TEXCON[2:1]) setting is happened.</p> <p>For example, while TEXIEN = 1, TEXEN = 1, and TEX_EDGE = 00, a 1 to 0 transition on the TEX pin will cause the TEXIF(TEXISR[0]) interrupt flag to be set then the interrupt signal is generated and sent to NVIC to inform CPU.</p>
[4]	RSTCAPSEL	<p>Timer External Reset Counter / Capture Mode Selection</p> <p>1 = TEX transition is using as the timer counter reset function.</p>



		0 = TEX transition is using as the timer capture function.
[3]	TEXEN	<p>Timer External Pin Enable</p> <p>This bit enables the reset/capture function on the TEX pin.</p> <p>1 = The transition detected on the TEX pin will result in capture or reset of timer counter.</p> <p>0 = The TEX pin will be ignored.</p>
[2:1]	TEX_EDGE	<p>Timer External Pin Edge Detection</p> <p>00 = a 1 to 0 transition on TEX will be detected.</p> <p>01 = a 0 to 1 transition on TEX will be detected.</p> <p>10 = either 1 to 0 or 0 to 1 transition on TEX will be detected.</p> <p>11 = Reserved.</p>
[0]	TX_PHASE	<p>Timer External Count Phase</p> <p>This bit indicates the external count pin phase.</p> <p>1 = A rising edge of external count pin will be counted.</p> <p>0 = A falling edge of external count pin will be counted.</p>



Timer External Interrupt Status Register (TEXISR)

Register	Offset	R/W	Description	Reset Value
TEXISR0	TMR_BA01+0x18	R/W	Timer0 External Interrupt Status Register	0x0000_0000
TEXISR1	TMR_BA01+0x38	R/W	Timer1 External Interrupt Status Register	0x0000_0000
TEXISR2	TMR_BA23+0x18	R/W	Timer2 External Interrupt Status Register	0x0000_0000
TEXISR3	TMR_BA23+0x38	R/W	Timer3 External Interrupt Status Register	0x0000_0000

31	30	29	28	27	26	25	24
Reserved							
23	22	21	20	19	18	17	16
Reserved							
15	14	13	12	11	10	9	8
Reserved							
7	6	5	4	3	2	1	0
Reserved							TEXIF

Bits	Description	
[31:1]	Reserved	Reserved
[0]	TEXIF	<p>Timer External Interrupt Flag</p> <p>This bit indicates the external interrupt status of Timer.</p> <p>This bit is set by hardware when TEXEN (TEXCON[3]) is to 1, and the transition on the TEX pins associated with TEX_EDGE (TEXCON[2:1]) setting is occurred. It is cleared by writing 1 to this bit.</p> <p>For example, while TEXEN = 1, and TEX_EDGE = 00, a 1 to 0 transition on the TEX pin causes the TEXIF to be set.</p>



5.11 Watchdog Timer (WDT)

5.11.1 Overview

The purpose of Watchdog Timer is to perform a system reset when system runs into an unknown state. This prevents system from hanging for an infinite period of time. Besides, this Watchdog Timer supports another function to wake-up chip from Power-down mode. The watchdog timer includes an 18-bit free running counter with programmable time-out intervals. Table 5-8 show the watchdog timeout interval selection and Figure 5-64 shows the timing of watchdog interrupt signal and reset signal.

Setting WTE (WDTCR [7]) enables the watchdog timer and the WDT counter starts counting up. When the counter reaches the selected time-out interval, Watchdog timer interrupt flag WTIF will be set immediately to request a WDT interrupt if the watchdog timer interrupt enable bit WTIE is set, in the meanwhile, a specified delay time ($1024 * T_{WDT}$) follows the time-out event. User must set WTR (WDTCR [0]) (Watchdog timer reset) high to reset the 18-bit WDT counter to avoid chip from Watchdog timer reset before the delay time expires. WTR bit is cleared automatically by hardware after WDT counter is reset. There are eight time-out intervals with specific delay time which are selected by Watchdog timer interval select bits WTIS (WDTCR [10:8]). If the WDT counter has not been cleared after the specific delay time expires, the watchdog timer will set Watchdog Timer Reset Flag (WTRF) high and reset chip. This reset will last 63 WDT clocks (T_{RST}) then chip restarts executing program from reset vector (0x0000_0000). WTRF will not be cleared by Watchdog reset. User may poll WTRF by software to recognize the reset source. WDT also provides wake-up function. When chip is powered down and the Watchdog Timer Wake-up Function Enable bit (WDTR[4]) is set, if the WDT counter reaches the specific time interval defined by WTIS (WDTCR [10:8]), the chip is woken up from Power-down state. As to the first example, if WTIS is set as 000, the specific time interval for chip to wake up from Power-down state is $2^4 * T_{WDT}$. When power down command is set by software, then, chip enters Power-down state. After $2^4 * T_{WDT}$ time is elapsed, chip is woken up from Power-down state. As to the second example, if WTIS (WDTCR [10:8]) is set as 111, the specific time interval for chip to wake up from Power-down state is $2^{18} * T_{WDT}$. If power down command is set by software, then, chip enters Power-down state. After $2^{18} * T_{WDT}$ time is elapsed, chip is woken up from Power-down state. Note that if WTRE (WDTCR [1]) is set to 1, after chip is woken up, software should clear the Watchdog Timer counter by setting WTR(WDTCR [0]) to 1 as soon as possible. Otherwise, if the Watchdog Timer counter is not cleared by setting WTR (WDTCR [0]) to 1 before time starting from waking up to software clearing Watchdog Timer counter is over $1024 * T_{WDT}$, the chip is reset by Watchdog Timer.



WTIS	Timeout Interval Selection T_{TIS}	Interrupt Period T_{INT}	WTR Timeout starting Interval (WDT_CLK=10 kHz) MIN. T_{WTR} ~ Max. T_{WTR}
000	$2^4 * T_{WDT}$	$1024 * T_{WDT}$	1.6 ms ~ 104 ms
001	$2^6 * T_{WDT}$	$1024 * T_{WDT}$	6.4 ms ~ 108.8 ms
010	$2^8 * T_{WDT}$	$1024 * T_{WDT}$	25.6 ms ~ 128 ms
011	$2^{10} * T_{WDT}$	$1024 * T_{WDT}$	102.4 ms ~ 204.8 ms
100	$2^{12} * T_{WDT}$	$1024 * T_{WDT}$	409.6 ms ~ 512 ms
101	$2^{14} * T_{WDT}$	$1024 * T_{WDT}$	1.6384 s ~ 1.7408 s
110	$2^{16} * T_{WDT}$	$1024 * T_{WDT}$	6.5536 s ~ 6.656 s
111	$2^{18} * T_{WDT}$	$1024 * T_{WDT}$	26.2144 s ~ 26.3168 s

Table 5-8 Watchdog Timeout Interval Selection

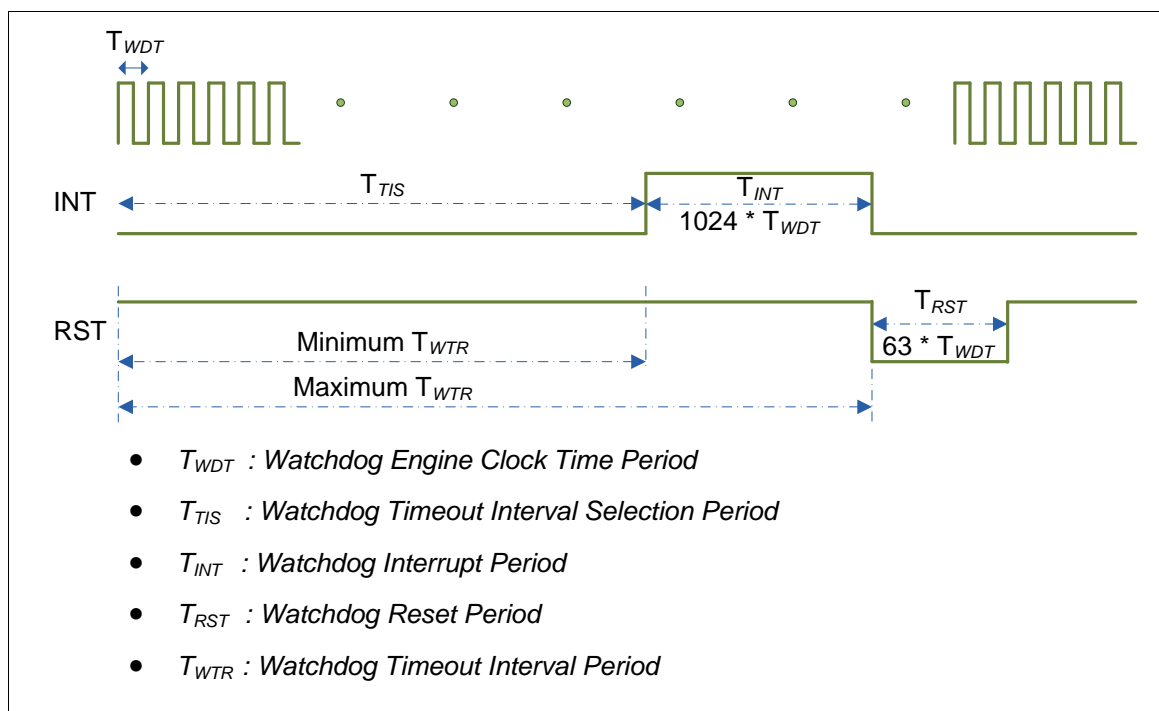

Figure 5-66 Timing of Interrupt and Reset Signal



5.11.2 Features

- 18-bit free running counter to avoid chip from Watchdog timer reset before the delay time expires.
- Selectable time-out interval ($2^4 \sim 2^{18}$) and the time out interval is 104 ms \sim 26.3168 s (if WDT_CLK = 10 kHz).
- Reset period = $(1 / 10 \text{ kHz}) * 63$, if WDT_CLK = 10 kHz.

5.11.3 Block Diagram

The Watchdog Timer clock control and block diagram are shown as follows.

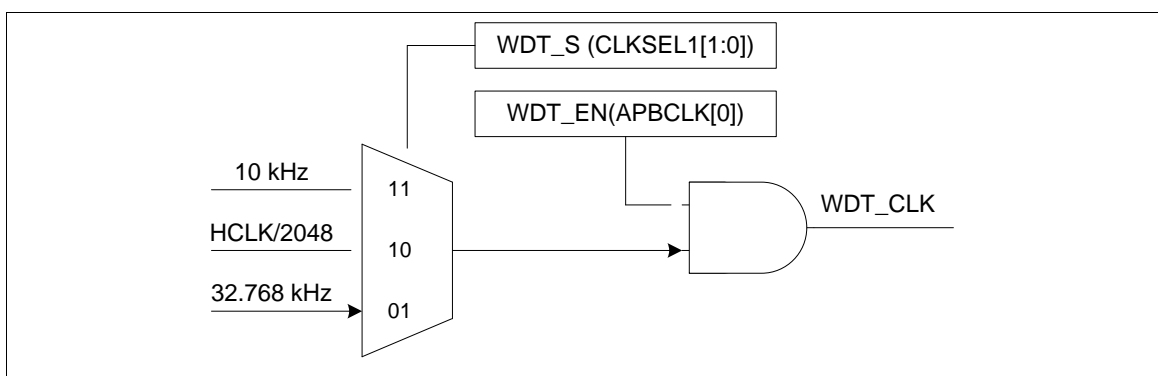

Figure 5-67 Watchdog Timer Clock Control

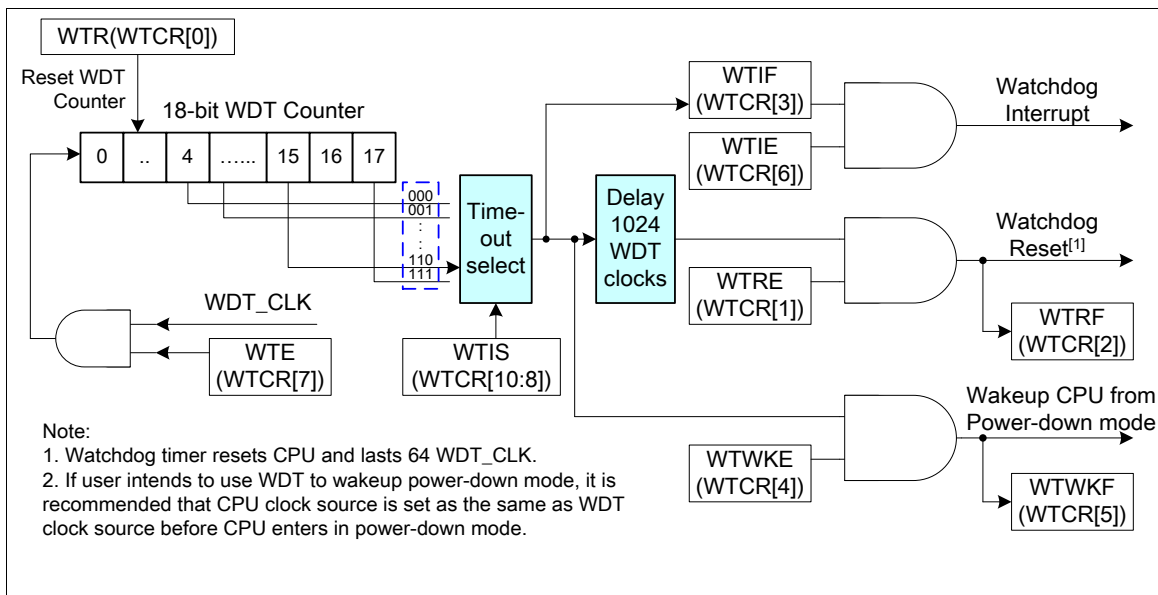

Figure 5-68 Watchdog Timer Block Diagram



5.11.4 Register Map

R: read only, W: write only, R/W: both read and write

Register	Offset	R/W	Description	Reset Value
WDT Base Address: WDT_BA = 0x4000_4000				
WTCR	WDT_BA+0x00	R/W	Watchdog Timer Control Register	0x0000_0700



5.11.5 Register Description

Watchdog Timer Control Register (WTCR)

Register	Offset	R/W	Description	Reset Value
WTCR	WDT_BA+0x00	R/W	Watchdog Timer Control Register	0x0000_0700

Note: All bits can be write in this register are write-protected. To program it needs to write "59h", "16h", "88h" to address 0x5000_0100 to disable register protection. Refer to the register REGWRPROT at address GCR_BA+0x100.

31	30	29	28	27	26	25	24
DBGACK_WDT		Reserved					
23	22	21	20	19	18	17	16
Reserved							
15	14	13	12	11	10	9	8
Reserved					WTIS		
7	6	5	4	3	2	1	0
WTE	WTIE	WTWKF	WTWKE	WTIF	WTRF	WTRE	WTR

Bits	Description																																
[31]	<p>DBGACK_WDT</p> <p>ICE Debug Mode Acknowledge Disable (Write-protection Bit) 0 = ICE debug mode acknowledgement effects Watchdog Timer counting. Watchdog Timer counter will be held while ICE debug mode acknowledged. 1 = ICE debug mode acknowledgement Disabled. Watchdog Timer counter will keep going no matter ICE debug mode acknowledged or not.</p>																																
[30:11]	<p>Reserved</p> <p>Reserved</p>																																
[10:8]	<p>WTIS</p> <p>Watchdog Timer Interval Selection (Write-protection Bits) These three bits select the timeout interval for the Watchdog timer.</p> <table border="1" style="width: 100%; text-align: center;"> <thead> <tr> <th>WTIS</th> <th>Timeout Interval Selection</th> <th>Interrupt Period</th> <th>WTR Timeout Interval (WDT_CLK=10 kHz)</th> </tr> </thead> <tbody> <tr> <td>000</td> <td>$2^4 * T_{WDT}$</td> <td>$(2^4 + 1024) * T_{WDT}$</td> <td>1.6 ms ~ 104 ms</td> </tr> <tr> <td>001</td> <td>$2^6 * T_{WDT}$</td> <td>$(2^6 + 1024) * T_{WDT}$</td> <td>6.4 ms ~ 108.8 ms</td> </tr> <tr> <td>010</td> <td>$2^8 * T_{WDT}$</td> <td>$(2^8 + 1024) * T_{WDT}$</td> <td>25.6 ms ~ 128 ms</td> </tr> <tr> <td>011</td> <td>$2^{10} * T_{WDT}$</td> <td>$(2^{10} + 1024) * T_{WDT}$</td> <td>102.4 ms ~ 204.8 ms</td> </tr> <tr> <td>100</td> <td>$2^{12} * T_{WDT}$</td> <td>$(2^{12} + 1024) * T_{WDT}$</td> <td>409.6 ms ~ 512 ms</td> </tr> <tr> <td>101</td> <td>$2^{14} * T_{WDT}$</td> <td>$(2^{14} + 1024) * T_{WDT}$</td> <td>1.6384 s ~ 1.7408 s</td> </tr> <tr> <td>110</td> <td>$2^{16} * T_{WDT}$</td> <td>$(2^{16} + 1024) * T_{WDT}$</td> <td>6.5536 s ~ 6.656 s</td> </tr> </tbody> </table>	WTIS	Timeout Interval Selection	Interrupt Period	WTR Timeout Interval (WDT_CLK=10 kHz)	000	$2^4 * T_{WDT}$	$(2^4 + 1024) * T_{WDT}$	1.6 ms ~ 104 ms	001	$2^6 * T_{WDT}$	$(2^6 + 1024) * T_{WDT}$	6.4 ms ~ 108.8 ms	010	$2^8 * T_{WDT}$	$(2^8 + 1024) * T_{WDT}$	25.6 ms ~ 128 ms	011	$2^{10} * T_{WDT}$	$(2^{10} + 1024) * T_{WDT}$	102.4 ms ~ 204.8 ms	100	$2^{12} * T_{WDT}$	$(2^{12} + 1024) * T_{WDT}$	409.6 ms ~ 512 ms	101	$2^{14} * T_{WDT}$	$(2^{14} + 1024) * T_{WDT}$	1.6384 s ~ 1.7408 s	110	$2^{16} * T_{WDT}$	$(2^{16} + 1024) * T_{WDT}$	6.5536 s ~ 6.656 s
WTIS	Timeout Interval Selection	Interrupt Period	WTR Timeout Interval (WDT_CLK=10 kHz)																														
000	$2^4 * T_{WDT}$	$(2^4 + 1024) * T_{WDT}$	1.6 ms ~ 104 ms																														
001	$2^6 * T_{WDT}$	$(2^6 + 1024) * T_{WDT}$	6.4 ms ~ 108.8 ms																														
010	$2^8 * T_{WDT}$	$(2^8 + 1024) * T_{WDT}$	25.6 ms ~ 128 ms																														
011	$2^{10} * T_{WDT}$	$(2^{10} + 1024) * T_{WDT}$	102.4 ms ~ 204.8 ms																														
100	$2^{12} * T_{WDT}$	$(2^{12} + 1024) * T_{WDT}$	409.6 ms ~ 512 ms																														
101	$2^{14} * T_{WDT}$	$(2^{14} + 1024) * T_{WDT}$	1.6384 s ~ 1.7408 s																														
110	$2^{16} * T_{WDT}$	$(2^{16} + 1024) * T_{WDT}$	6.5536 s ~ 6.656 s																														



		111	$2^{18} * T_{WDT}$	$(2^{18} + 1024) * T_{WDT}$	26.2144 s ~ 26.3168 s
[7]	WTE	Watchdog Timer Enable (Write-protection Bit) 0 = Watchdog timer Disabled (this action will reset the internal counter). 1 = Watchdog timer Enabled.			
[6]	WTIE	Watchdog Timer Interrupt Enable (Write-protection Bit) 0 = Watchdog timer interrupt Disabled 1 = Watchdog timer interrupt Enabled			
[5]	WTWKF	Watchdog Timer Wake-up Flag If Watchdog timer causes chip wakes up from Power-down mode, this bit will be set to high. It must be cleared by software with a write 1 to this bit. 0 = Watchdog timer does not cause chip wake-up. 1 = Chip wake-up from idle or Power-down mode by Watchdog timeout.			
[4]	WTWKE	Watchdog Timer Wake-up Function Enable bit (Write-protection Bit) 0 = Watchdog timer Wake-up chip function Disabled. 1 = Wake-up function Enabled so that Watchdog timer timeout can wake up chip from Power-down mode. Note: Chip can wake-up by WDT only if WDT clock source select RC10K			
[3]	WTIF	Watchdog Timer Interrupt Flag If the Watchdog timer interrupt is enabled, then the hardware will set this bit to indicate that the Watchdog timer interrupt has occurred. 0 = Watchdog timer interrupt did not occur 1 = Watchdog timer interrupt occurred Note: This bit is cleared by writing 1 to this bit.			
[2]	WTRF	Watchdog Timer Reset Flag When the Watchdog timer initiates a reset, the hardware will set this bit. This flag can be read by software to determine the source of reset. Software is responsible to clear it manually by writing 1 to it. If WTRE is disabled, then the Watchdog timer has no effect on this bit. 0 = Watchdog timer reset did not occur 1 = Watchdog timer reset occurred Note: This bit is cleared by writing 1 to this bit.			
[1]	WTRE	Watchdog Timer Reset Enable (Write-protection Bit) Setting this bit will enable the Watchdog timer reset function. 0 = Watchdog timer reset function Disabled 1 = Watchdog timer reset function Enabled			
[0]	WTR	Clear Watchdog Timer (Write-protection Bit) Setting this bit will clear the Watchdog timer. 0 = No effect 1 = Reset the contents of the Watchdog timer Note: This bit will be auto cleared by hardware			



5.12 UART Interface Controller (UART)

The NuMicro™ NUC130/NUC140 provides up to three channels of Universal Asynchronous Receiver/Transmitters (UART). UART0 supports High Speed UART and UART1~2 perform Normal Speed UART, besides, only UART0 and UART1 support flow control function.

5.12.1 Overview

The Universal Asynchronous Receiver/Transmitter (UART) performs a serial-to-parallel conversion on data received from the peripheral, and a parallel-to-serial conversion on data transmitted from the CPU. The UART controller also supports IrDA SIR Function, LIN Master/Slave mode function and RS-485 mode functions. Each UART channel supports seven types of interrupts including transmitter FIFO empty interrupt (INT_THRE), receiver threshold level reaching interrupt (INT_RDA), line status interrupt (parity error or framing error or break interrupt) (INT_RLS), receiver buffer time out interrupt (INT_TOUT), MODEM/Wake-up status interrupt (INT_MODEM), Buffer error interrupt (INT_BUF_ERR) and LIN receiver break field detected interrupt (INT_LIN_RX_BREAK). Interrupts of UART0 and UART2 share the interrupt number 12 (vector number is 28); Interrupt number 13 (vector number is 29) only supports UART1 interrupt. Refer to Nested Vectored Interrupt Controller chapter for System Interrupt Map.

The UART0 is built-in with a 64-byte transmitter FIFO (TX_FIFO) and a 64-byte receiver FIFO (RX_FIFO) that reduces the number of interrupts presented to the CPU and the UART1~2 are equipped 16-byte transmitter FIFO (TX_FIFO) and 16-byte receiver FIFO (RX_FIFO). The CPU can read the status of the UART at any time during the operation. The reported status information includes the type and condition of the transfer operations being performed by the UART, as well as 4 error conditions (parity error, framing error, break interrupt and buffer error) probably occur while receiving data. The UART includes a programmable baud rate generator that is capable of dividing clock input by divisors to produce the serial clock that transmitter and receiver need. The baud rate equation is $Baud\ Rate = \frac{UART_CLK}{M * [BRD + 2]}$, where M and BRD are defined in Baud Rate Divider Register (UA_BAUD). Table 5-9 lists the equations in the various conditions and Table 5-10 list the UART baud rate setting table.

Mode	DIV_X_EN	DIV_X_ONE	Divider X	BRD	Baud rate Equation
0	0	0	B	A	$UART_CLK / [16 * (A+2)]$
1	1	0	B	A	$UART_CLK / [(B+1) * (A+2)]$, B must ≥ 8
2	1	1	Don't care	A	$UART_CLK / (A+2)$, A must ≥ 7

Table 5-9 UART Baud Rate Equation

System Clock = Internal 22.1184 MHz High Speed Oscillator						
Baud Rate	Mode0		Mode1		Mode2	
	Parameter	Register	Parameter	Register	Parameter	Register
921600	x	x	A=0,B=11	0x2B00_0000	A=22	0x3000_0016
460800	A=1	0x0000_0001	A=1,B=15 A=2,B=11	0x2F00_0001 0x2B00_0002	A=46	0x3000_002E
230400	A=4	0x0000_0004	A=4,B=15 A=6,B=11	0x2F00_0004 0x2B00_0006	A=94	0x3000_005E



115200	A=10	0x0000_000A	A=10,B=15 A=14,B=11	0x2F00_000A 0x2B00_000E	A=190	0x3000_00BE
57600	A=22	0x0000_0016	A=22,B=15 A=30,B=11	0x2F00_0016 0x2B00_001E	A=382	0x3000_017E
38400	A=34	0x0000_0022	A=62,B=8 A=46,B=11 A=34,B=15	0x2800_003E 0x2B00_002E 0x2F00_0022	A=574	0x3000_023E
19200	A=70	0x0000_0046	A=126,B=8 A=94,B=11 A=70,B=15	0x2800_007E 0x2B00_005E 0x2F00_0046	A=1150	0x3000_047E
9600	A=142	0x0000_008E	A=254,B=8 A=190,B=11 A=142,B=15	0x2800_00FE 0x2B00_00BE 0x2F00_008E	A=2302	0x3000_08FE
4800	A=286	0x0000_011E	A=510,B=8 A=382,B=11 A=286,B=15	0x2800_01FE 0x2B00_017E 0x2F00_011E	A=4606	0x3000_11FE

Table 5-10 UART Baud Rate Setting Table

The UART0 and UART1 controllers support auto-flow control function that uses two low-level signals, /CTS (clear-to-send) and /RTS (request-to-send), to control the flow of data transfer between the UART and external devices (ex: Modem). When auto-flow is enabled, the UART is not allowed to receive data until the UART asserts /RTS to external device. When the number of bytes in the RX FIFO equals the value of RTS_TRI_LEV (UA_FCR [19:16]), the /RTS is de-asserted. The UART sends data out when UART controller detects /CTS is asserted from external device. If a valid asserted /CTS is not detected the UART controller will not send data out.

The UART controllers also provides Serial IrDA (SIR, Serial Infrared) function (User must set IrDA_EN (UA_FUN_SEL [1]) to enable IrDA function). The SIR specification defines a short-range infrared asynchronous serial transmission mode with one start bit, 8 data bits, and 1 stop bit. The maximum data rate is 115.2 Kbps (half duplex). The IrDA SIR block contains an IrDA SIR Protocol encoder/decoder. The IrDA SIR protocol is half-duplex only. So it cannot transmit and receive data at the same time. The IrDA SIR physical layer specifies a minimum 10ms transfer delay between transmission and reception. This delay feature must be implemented by software.

The alternate function of UART controllers is LIN (Local Interconnect Network) function. The LIN mode is selected by setting the UA_FUN_SEL[1:0] to '01'. In LIN mode, one start bit and 8-bit data format with 1-bit stop bit are required in accordance with the LIN standard.

For NuMicro™ NUC100 Series, another alternate function of UART controllers is RS-485 9-bit mode function, and direction control provided by RTS pin or can program GPIO (PB.2 for RTS0 and PB.6 for RTS1) to implement the function by software. The RS-485 mode is selected by setting the UA_FUN_SEL register to select RS-485 function. The RS-485 driver control is implemented using the RTS control signal from an asynchronous serial port to enable the RS-485 driver. In RS-485 mode, many characteristics of the RX and TX are same as UART.



5.12.2 Features

- Full duplex, asynchronous communications
- Separates receive/transmit 64/16/16 bytes (UART0/UART1/UART2) entry FIFO for data payloads
- Supports hardware auto flow control/flow control function (CTS, RTS) and programmable RTS flow control trigger level (UART0 and UART1 support)
- Programmable receiver buffer trigger level
- Supports programmable baud-rate generator for each channel individually
- Supports CTS wake-up function (UART0 and UART1 support)
- Supports 7-bit receiver buffer time out detection function
- UART0/UART1 can be served by the DMA controller
- Programmable transmitting data delay time between the last stop and the next start bit by setting UA_TOR [DLY] register
- Supports break error, frame error, parity error and receive / transmit buffer overflow detect function
- Fully programmable serial-interface characteristics
 - Programmable number of data bit, 5-, 6-, 7-, 8-bit character
 - Programmable parity bit, even, odd, no parity or stick parity bit generation and detection
 - Programmable stop bit, 1, 1.5, or 2 stop bit generation
- Supports IrDA SIR Function mode
 - Supports 3-/16-bit duration for normal mode
- Supports LIN function mode
 - Supports LIN master/Slave mode
 - Supports programmable break generation function for transmitter
 - Supports break detect function for receiver
- Supports RS-485 Function mode
 - Supports RS-485 9-bit mode
 - Supports hardware or software direct enable control provided by RTS pin



5.12.3 Block Diagram

The UART clock control and block diagram are shown in Figure 5-67 and Figure 5-68.

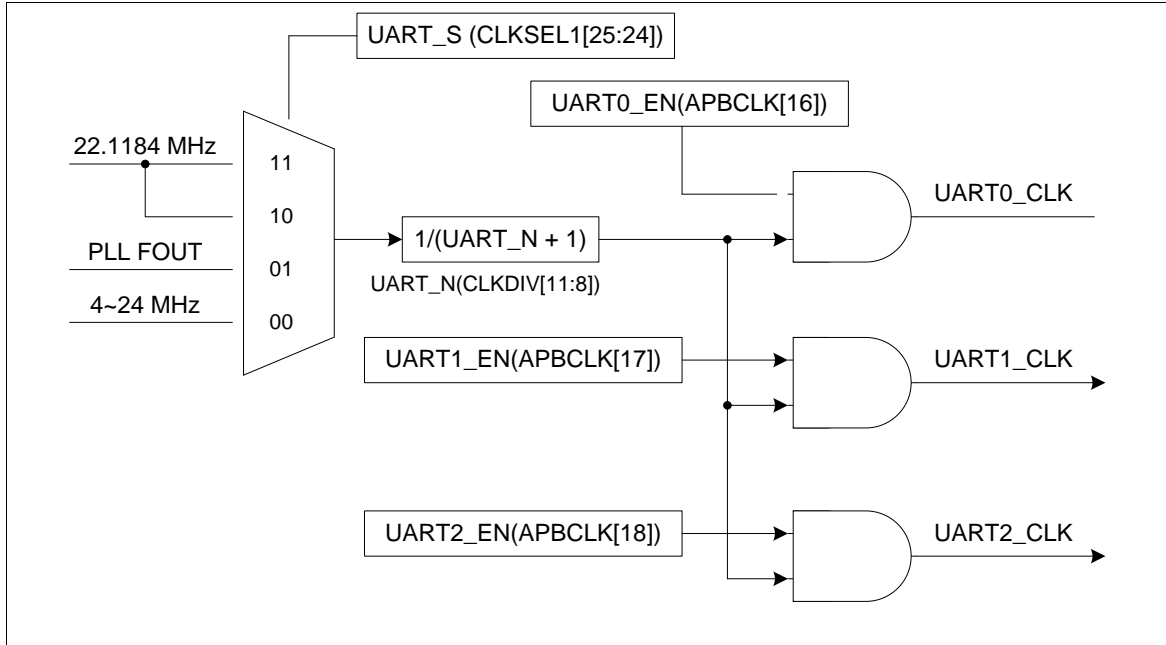

Figure 5-69 UART Clock Control Diagram

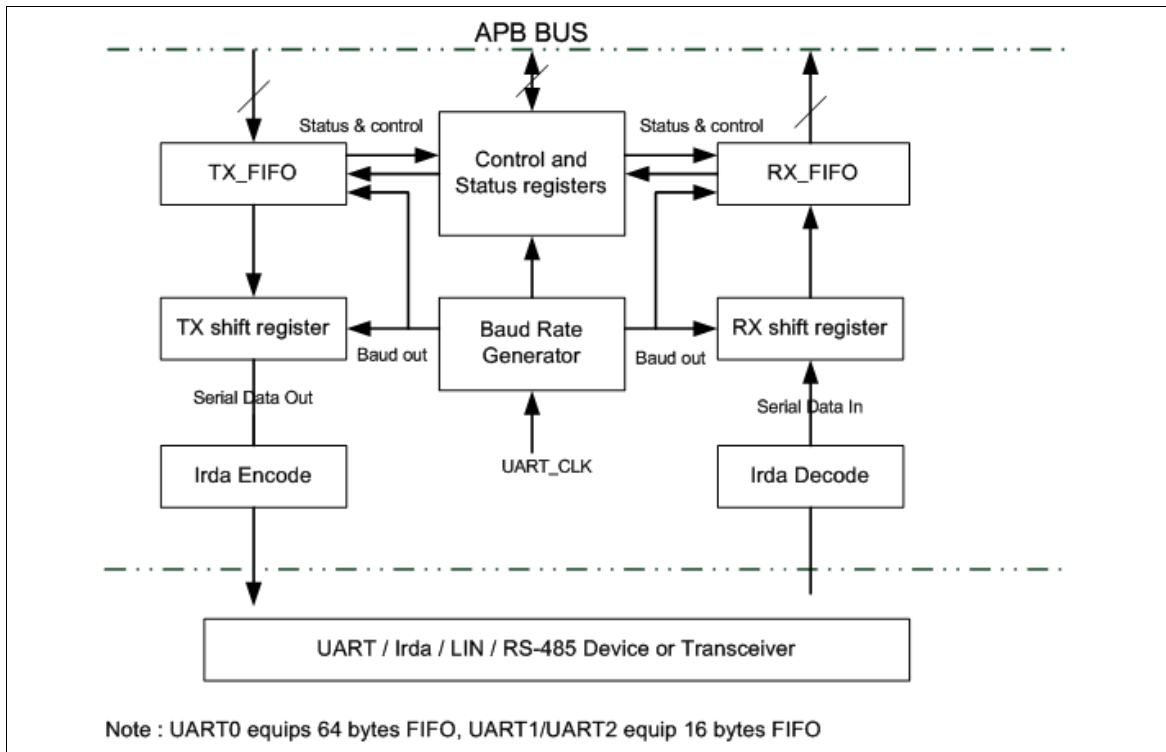

Figure 5-70 UART Block Diagram

**TX_FIFO**

The transmitter is buffered with a 64/16 byte FIFO to reduce the number of interrupts presented to the CPU.

RX_FIFO

The receiver is buffered with a 64/16 byte FIFO (plus three error bits per byte) to reduce the number of interrupts presented to the CPU.

TX shift Register

This block is the shifting the transmitting data out serially control block.

RX shift Register

This block is the shifting the receiving data in serially control block.

Modem Control Register

This register controls the interface to the MODEM or data set (or a peripheral device emulating a MODEM).

Baud Rate Generator

Divide the external clock by the divisor to get the desired baud rate clock. Refer to baud rate equation.

IrDA Encode

This block is IrDA encode control block.

IrDA Decode

This block is IrDA decode control block.

Control and Status Register

This field is register set that including the FIFO control registers (UA_FCR), FIFO status registers (UA_FSR), and line control register (UA_LCR) for transmitter and receiver. The time out control register (UA_TOR) identifies the condition of time out interrupt. This register set also includes the interrupt enable register (UA_IER) and interrupt status register (UA_ISR) to enable or disable the responding interrupt and to identify the occurrence of the responding interrupt. There are seven types of interrupts, transmitter FIFO empty interrupt (INT_THRE), receiver threshold level reaching interrupt (INT_RDA), line status interrupt (parity error or framing error or break interrupt) (INT_RLS), time out interrupt (INT_TOUT), MODEM/Wake-up status interrupt (INT_MODEM), Buffer error interrupt (INT_BUF_ERR) and LIN receiver break field detected interrupt (INT_LIN_RX_BREAK).

The following diagram demonstrates the auto-flow control block diagram.

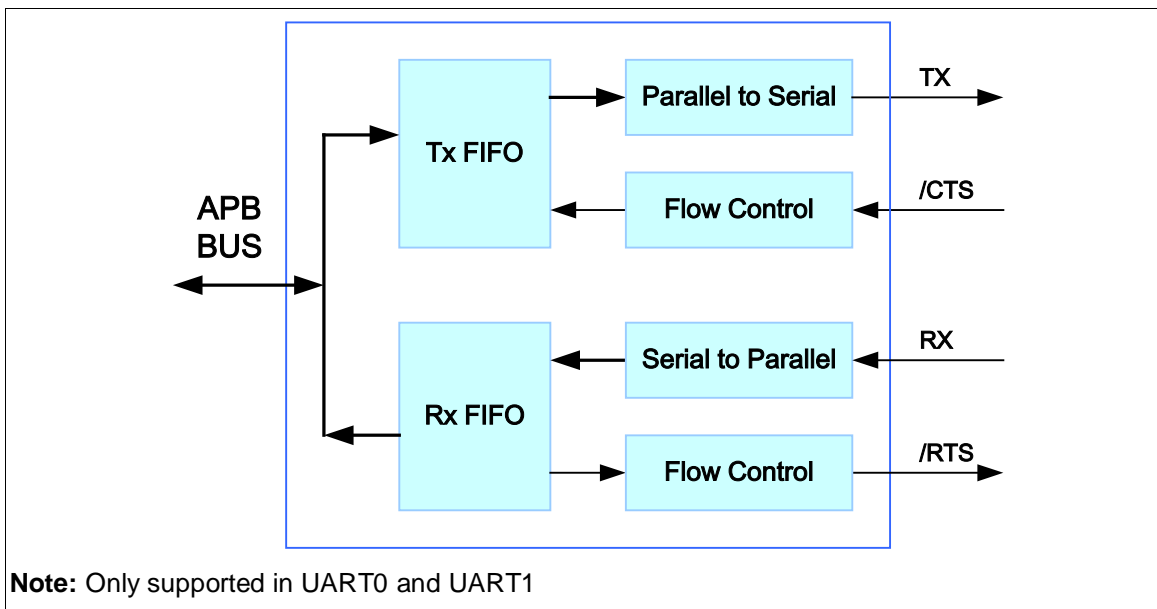

Figure 5-71 Auto Flow Control Block Diagram



5.12.4 IrDA Mode

The UART supports IrDA SIR (Serial Infrared) Transmit Encoder and Receive Decoder, and IrDA mode is selected by setting the **IrDA_EN** bit in **UA_FUN_SEL** register.

In IrDA mode, the UA_BAUD [DIV_X_EN] register must be disabled.

Baud Rate = Clock / (16 * BRD), where BRD is Baud Rate Divider in UA_BAUD register.

The following diagram demonstrates the IrDA control block diagram.

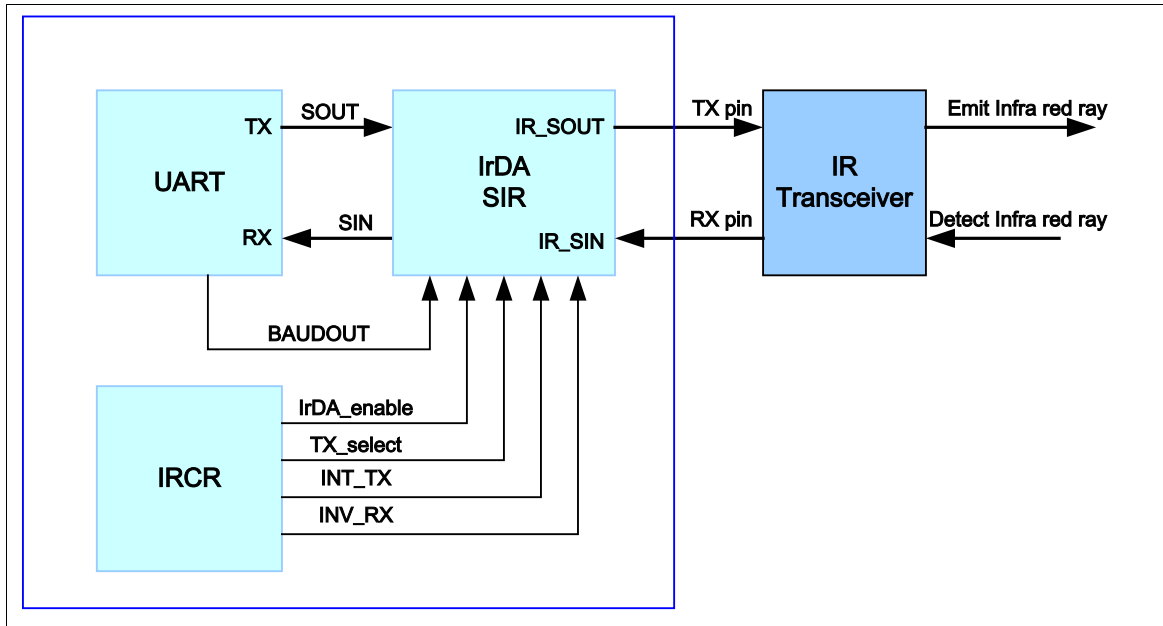

Figure 5-72 IrDA Block Diagram

5.12.4.1 IrDA SIR Transmit Encoder

The IrDA SIR Transmit Encoder modulates Non-Return-to Zero (NRZ) transmit bit stream output from UART. The IrDA SIR physical layer specifies use of Return-to-Zero, Inverted (RZI) modulation scheme which represent logic 0 as an infra light pulse. The modulated output pulse stream is transmitted to an external output driver and infrared Light Emitting Diode.

In normal mode, the transmitted pulse width is specified as 3/16 period of baud rate.

5.12.4.2 IrDA SIR Receive Decoder

The IrDA SIR Receive Decoder demodulates the return-to-zero bit stream from the input detector and outputs the NRZ serial bits stream to the UART received data input. The decoder input is normally high in the idle state. (Because of this, IRCR bit 6 should be set as 1 by default)

A start bit is detected when the decoder input is LOW

5.12.4.3 IrDA SIR Operation

The IrDA SIR Encoder/decoder provides functionality that converts between UART data stream and half duplex serial SIR interface. The following diagram is the IrDA encoder/decoder waveform:

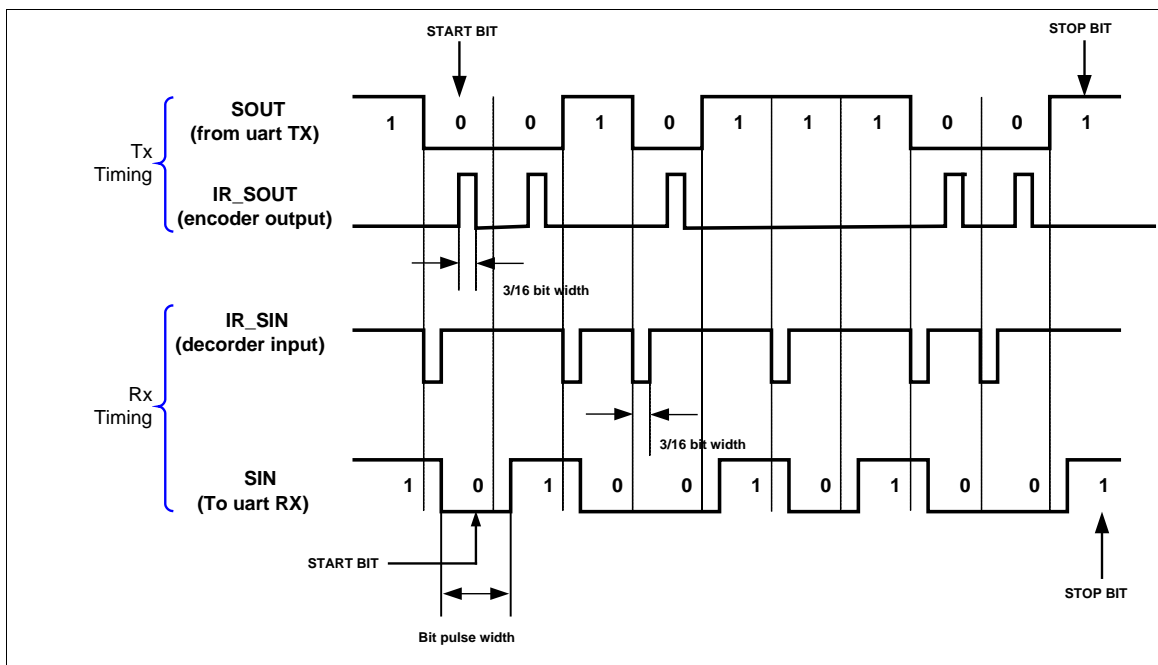

Figure 5-73 IrDA TX/RX Timing Diagram

5.12.5 LIN (Local Interconnection Network) Mode

The UART supports LIN function, and LIN mode is selected by setting the UA_FUN_SEL[1:0] to '01'. In LIN mode, each byte field is initiated by a start bit with value zero (dominant), followed by 8 data bits (LSB is first) and ended by 1 stop bit with value one (recessive) in accordance with the LIN standard. The following diagram is the structure of LIN function mode:

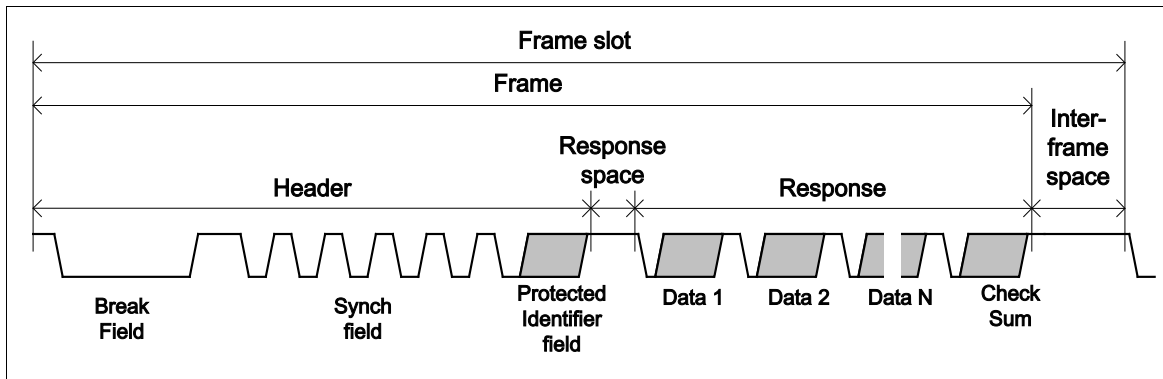

Figure 5-74 Structure of LIN Frame

The program flow of LIN Bus Transmit transfer (TX) is shown as follows:

1. Setting the UA_FUN_SEL[1:0] to '01' to enable LIN Bus mode.
2. Fill UA_LIN_BKFL in UA_LIN_BCNT to choose break field length. (The break field length is UA_LIN_BKFL + 2).
3. Setting the LIN_TX_EN bit in UA_LIN_BCNT register to start transmission (When break filed operation is finished, LIN_TX_EN will be cleared automatically).
4. Fill 0x55 to UA_THR to request synch field transmission.
5. Request Identifier Field transmission by writing the protected identifier value in the UA_THR
6. When the STOP bit of the last byte THR has been sent to bus, hardware will set flag TE_FLAG in UA_FSR to 1.
7. Fill N bytes data and Checksum to UA_THR then repeat step 5 and 6 to transmit the data.

The program flow of LIN Bus Receiver transfer (RX) is shown as follows:

1. Setting the UA_FUN_SEL[1:0] to '01' to enable LIN Bus mode.
2. Setting the LIN_RX_EN bit in UA_LIN_BCNT register to enable LIN RX mode.
3. Waiting for the flag LIN_RX_BREAK_IF in UA_ISR to check RX received Break field or not.
4. Waiting for the flag RDA_IF in UA_ISR and read back the UR_RBR register.

5.12.6 RS-485 Function Mode

The UART supports the **RS-485 9-bit mode function**. The RS-485 mode is selected by setting the UA_FUN_SEL register to select RS-485 function. The RS-485 driver control is implemented using the RTS control signal from an asynchronous serial port to enable the RS-485 driver. In RS-485 mode, many characteristics of the RX and TX are same as UART.

In RS-485 mode, the controller can configuration of it as an RS-485 addressable slave and the RS-485 master transmitter will identify an address character by setting the parity (9th bit) to 1. For data characters, the parity is set to 0. Software can use UA_LCR register to control the 9-th bit (When the PBE, EPE and SPE are set, the 9-th bit is transmitted 0 and when PBE and SPE are set and EPE is cleared, the 9-th bit is transmitted 1). The Controller support three operation modes including RS-485 Normal Multidrop Operation Mode (NMM), RS-485 Auto Address Detection Operation Mode (AAD) and RS-485 Auto Direction Control Operation Mode (AUD). Software can choose any of the operation modes by programming UA_RS-485_CSR register, and software can drive the transfer delay time between the last stop bit leaving the TX-FIFO and the de-assertion of by setting UA_TOR [DLY] register.

RS-485 Normal Multidrop Operation Mode (NMM)

In RS-485 Normal Multidrop Operation mode, first, software must decide if the data before the address byte detected will be stored in RX-FIFO or not. If software want to ignore any data before address byte detected, the flow is set UART_FCR[RS485_RX_DIS] then enable UA_RS-485[RS485_NMM] and the receiver will ignore any data until an address byte is detected (bit9 =1) and the address byte data will be stored in the RX-FIFO. If software wants to receive any data before address byte detected, the flow is disable UART_FCR [RS485_RX_DIS] then enable UA_RS-485[RS485_NMM] and the receiver will received any data. If an address byte is detected (bit9 =1), it will generator an interrupt to CPU and software can decide whether enable or disable receiver to accept the following data byte by setting UA_RS-485_CSR [RX_DIS]. If the receiver is be enabled, all received byte data will be accepted and stored in the RX-FIFO, and if the receiver is disabled, all received byte data will be ignore until the next address byte be detected. If software disable receiver by setting UA_RS-485_CSR [RX_DIS] register, when a next address byte be detected, the controller will clear the UA_RS-485_CSR [RX_DIS] bit and the address byte data will be stored in the RX-FIFO.

RS-485 Auto Address Detection Operation Mode (AAD)

In RS-485 Auto Address Detection Operation mode, the receiver will ignore any data until an address byte is detected (bit9 =1) and the address byte data matches the UA_RS-485[ADDR_MATCH] value. The address byte data will be stored in the RX-FIFO. The all received byte data will be accepted and stored in the RX-FIFO until and address byte data not match the UA_RS-485[ADDR_MATCH] value.

RS-485 Auto Direction Mode (AUD)

Another option function of RS-485 controllers is **RS-485 auto direction control function**. The RS-485 driver control is implemented using the RTS control signal from an asynchronous serial port to enable the RS-485 driver. The RTS line is connected to the RS-485 driver enable such that setting the RTS line to high (logic 1) enables the RS-485 driver. Setting the RTS line to low (logic 0) puts the driver into the tri-state condition. User can setting LEV_RTS in UA_MCR register to change the RTS driving level.

Program Sequence example:

1. Program FUN_SEL in UA_FUN_SEL to select RS-485 function.
2. Program the RX_DIS bit in UA_FCR register to determine enable or disable RS-485 receiver
3. Program the RS-485_NMM or RS-485_AAD mode.
4. If the RS-485_AAD mode is selected, the ADDR_MATCH is programmed for auto address match value.
5. Determine auto direction control by programming RS-485_AUD.

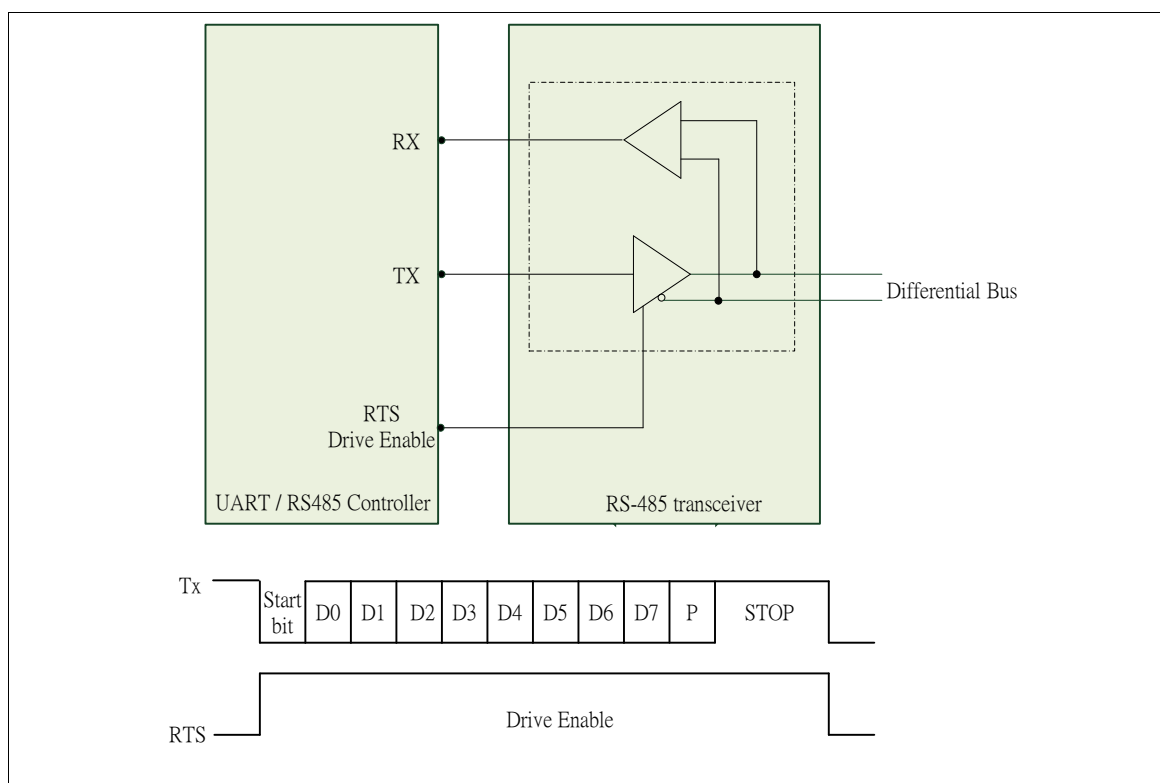

Figure 5-75 Structure of RS-485 Frame



5.12.7 Register Map

R: read only, W: write only, R/W: both read and write

Register	Offset	R/W	Description	Reset Value
UART Base Address:				
UART0_BA = 0x4005_0000				
UART1_BA = 0x4015_0000				
UART2_BA = 0x4015_4000				
UA_RBR	UART0_BA+0x00 UART1_BA+0x00 UART2_BA+0x00	R	UART Receive Buffer Register	Undefined
UA_THR	UART0_BA+0x00 UART1_BA+0x00 UART2_BA+0x00	W	UART Transmit Holding Register	Undefined
UA_IER	UART0_BA+0x04 UART1_BA+0x04 UART2_BA+0x04	R/W	UART Interrupt Enable Register	0x0000_0000
UA_FCR	UART0_BA+0x08 UART1_BA+0x08 UART2_BA+0x08	R/W	UART FIFO Control Register	0x0000_0101
UA_LCR	UART0_BA+0x0C UART1_BA+0x0C UART2_BA+0x0C	R/W	UART Line Control Register	0x0000_0000
UA_MCR	UART0_BA+0x10 UART1_BA+0x10 UART2_BA+0x10	R/W	UART Modem Control Register UART2: Reserved	0x0000_0200
UA_MSR	UART0_BA+0x14 UART1_BA+0x14 UART2_BA+0x14	R/W	UART Modem Status Register UART2: Reserved	0x0000_0110
UA_FSR	UART0_BA+0x18 UART1_BA+0x18 UART2_BA+0x18	R/W	UART FIFO Status Register	0x1040_4000



UA_ISR	UART0_BA+0x1C UART1_BA+0x1C UART2_BA+0x1C	R/W	UART Interrupt Status Register	0x0000_0002
UA_TOR	UART0_BA+0x20 UART1_BA+0x20 UART2_BA+0x20	R/W	UART Time Out Register	0x0000_0000
UA_BAUD	UART0_BA+0x24 UART1_BA+0x24 UART2_BA+0x24	R/W	UART Baud Rate Divisor Register	0x0F00_0000
UA_IRCR	UART0_BA+0x28 UART1_BA+0x28 UART2_BA+0x28	R/W	UART IrDA Control Register	0x0000_0040
UA_ALT_CSR	UART0_BA+0x2C UART1_BA+0x2C UART2_BA+0x2C	R/W	UART Alternate Control/Status Register	0x0000_0000
UA_FUN_SEL	UART0_BA+0x30 UART1_BA+0x30 UART2_BA+0x30	R/W	UART Function Select Register	0x0000_0000



5.12.8 Register Description

Receive Buffer Register (UA_RBR)

Register	Offset	R/W	Description	Reset Value
UA_RBR	UART0_BA+0x00 UART1_BA+0x00 UART2_BA+0x00	R	UART Receive Buffer Register	Undefined

31	30	29	28	27	26	25	24
Reserved							
23	22	21	20	19	18	17	16
Reserved							
15	14	13	12	11	10	9	8
Reserved							
7	6	5	4	3	2	1	0
RBR							

Bits	Description
[31:8]	Reserved
[7:0]	RBR Receive Buffer Register (Read Only) By reading this register, the UART will return an 8-bit data received from RX pin (LSB first).



Transmit Holding Register (UA_THR)

Register	Offset	R/W	Description	Reset Value
UA_THR	UART0_BA+0x00 UART1_BA+0x00 UART2_BA+0x00	W	UART Transmit Holding Register	Undefined

31	30	29	28	27	26	25	24
Reserved							
23	22	21	20	19	18	17	16
Reserved							
15	14	13	12	11	10	9	8
Reserved							
7	6	5	4	3	2	1	0
THR							

Bits	Description	
[31:8]	Reserved	Reserved
[7:0]	THR	Transmit Holding Register By writing to this register, the UART will send out an 8-bit data through the TX pin (LSB first).



Interrupt Enable Register (UA_IER)

Register	Offset	R/W	Description	Reset Value
UA_IER	UART0_BA+0x04 UART1_BA+0x04 UART2_BA+0x04	R/W	UART Interrupt Enable Register	0x0000_0000

31	30	29	28	27	26	25	24
Reserved							
23	22	21	20	19	18	17	16
Reserved							
15	14	13	12	11	10	9	8
DMA_RX_EN	DMA_TX_EN	AUTO_CTS_EN	AUTO_RTS_EN	TIME_OUT_EN	Reserved		LIN_RX_BRK_IEN
7	6	5	4	3	2	1	0
Reserved	WAKE_EN	BUF_ERR_IEN	RTO_IEN	MODEM_IEN	RLS_IEN	THRE_IEN	RDA_IEN

Bits	Description
[31:16]	Reserved Reserved
[15]	DMA_RX_EN RX DMA Enable (Not Available in UART2 Channel) This bit can enable or disable RX DMA service. 1 = RX DMA Enabled 0 = RX DMA Disabled
[14]	DMA_TX_EN TX DMA Enable (Not Available in UART2 Channel) This bit can enable or disable TX DMA service. 1 = TX DMA Enabled 0 = TX DMA Disabled
[13]	AUTO_CTS_EN CTS Auto Flow Control Enable (Not Available in UART2 Channel) 1 = CTS auto flow control Enabled 0 = CTS auto flow control Disabled When CTS auto-flow is enabled, the UART will send data to external device when CTS input assert (UART will not send data to device until CTS is asserted).
[12]	AUTO_RTS_EN RTS Auto Flow Control Enable (Not Available in UART2 Channel) 1 = RTS auto flow control Enabled 0 = RTS auto flow control Disabled When RTS auto-flow is enabled, if the number of bytes in the RX FIFO equals the UA_FCR [RTS_TRI_LEV], the UART will de-assert RTS signal.



[11]	TIME_OUT_EN	Time Out Counter Enable 1 = Time-out counter Enabled 0 = Time-out counter Disabled
[10:9]	Reserved	Reserved
[8]	LIN_RX_BRK_IEN	LIN RX Break Field Detected Interrupt Enable 1 = Lin bus RX break filed interrupt Enabled 0 = Lin bus RX break filed interrupt Masked off Note: This field is used for LIN function mode.
[7]	Reserved	Reserved
[6]	WAKE_EN	UART Wake-up Function Enable (Not Available in UART2 Channel) 0 = UART wake-up function Disabled 1 = UART wake-up function Enabled. When the chip is in Power-down mode, an external CTS change will wake-up chip from Power-down mode.
[5]	BUF_ERR_IEN	Buffer Error Interrupt Enable 1 = INT_BUF_ERR Enabled 0 = INT_BUF_ERR Masked off
[4]	RTO_IEN	RX Time Out Interrupt Enable 1 = INT_TOUT Enabled 0 = INT_TOUT Masked off
[3]	MODEM_IEN	Modem Status Interrupt Enable (Not Available in UART2 Channel) 1 = INT_MODEM Enabled 0 = INT_MODEM Masked off
[2]	RLS_IEN	Receive Line Status Interrupt Enable 1 = INT_RLS Enabled 0 = INT_RLS Masked off
[1]	THRE_IEN	Transmit Holding Register Empty Interrupt Enable 1 = INT_THRE Enabled 0 = INT_THRE Masked off
[0]	RDA_IEN	Receive Data Available Interrupt Enable. 1 = INT_RDA Enabled 0 = INT_RDA Masked off



FIFO Control Register (UA_FCR)

Register	Offset	R/W	Description	Reset Value
UA_FCR	UART0_BA+0x08 UART1_BA+0x08 UART2_BA+0x08	R/W	UART FIFO Control Register	0x0000_0101

31	30	29	28	27	26	25	24
Reserved							
23	22	21	20	19	18	17	16
Reserved				RTS_TRI_LEV			
15	14	13	12	11	10	9	8
Reserved							RX_DIS
7	6	5	4	3	2	1	0
RFITL				Reserved	TFR	RFR	Reserved

Bits	Description																		
[31:20]	Reserved																		
[19:16]	<p>RTS Trigger Level for Auto-Flow Control Use (Not Available in UART2 Channel)</p> <table border="1"> <thead> <tr> <th>RTS_TRI_LEV</th> <th>Trigger Level (Bytes)</th> </tr> </thead> <tbody> <tr><td>0000</td><td>01</td></tr> <tr><td>0001</td><td>04</td></tr> <tr><td>0010</td><td>08</td></tr> <tr><td>0011</td><td>14</td></tr> <tr><td>0100</td><td>30/14 (High Speed/Normal Speed)</td></tr> <tr><td>0101</td><td>46/14 (High Speed/Normal Speed)</td></tr> <tr><td>0110</td><td>62/14 (High Speed/Normal Speed)</td></tr> <tr><td>others</td><td>62/14 (High Speed/Normal Speed)</td></tr> </tbody> </table> <p>Note: This field is used for auto RTS flow control.</p>	RTS_TRI_LEV	Trigger Level (Bytes)	0000	01	0001	04	0010	08	0011	14	0100	30/14 (High Speed/Normal Speed)	0101	46/14 (High Speed/Normal Speed)	0110	62/14 (High Speed/Normal Speed)	others	62/14 (High Speed/Normal Speed)
RTS_TRI_LEV	Trigger Level (Bytes)																		
0000	01																		
0001	04																		
0010	08																		
0011	14																		
0100	30/14 (High Speed/Normal Speed)																		
0101	46/14 (High Speed/Normal Speed)																		
0110	62/14 (High Speed/Normal Speed)																		
others	62/14 (High Speed/Normal Speed)																		
[15:9]	Reserved																		
[8]	<p>Receiver Disable register.</p> <p>The receiver is disabled or not (set 1 to disable receiver)</p> <p>1 = Receiver Disabled. 0 = Receiver Enabled.</p> <p>Note: This field is used for RS-485 Normal Multi-drop mode. It should be programmed before UA_ALT_CSR [RS-485_NMM] is programmed.</p>																		



[7:4]	RFITL	RX FIFO Interrupt (INT_RDA) Trigger Level When the number of bytes in the receive FIFO equals the RFITL then the RDA_IF will be set (if UA_IER [RDA_IEN] is enable, an interrupt will generated).																		
		<table border="1"> <thead> <tr> <th>RFITL</th> <th>INTR_RDA Trigger Level (Bytes)</th> </tr> </thead> <tbody> <tr> <td>0000</td> <td>01</td> </tr> <tr> <td>0001</td> <td>04</td> </tr> <tr> <td>0010</td> <td>08</td> </tr> <tr> <td>0011</td> <td>14</td> </tr> <tr> <td>0100</td> <td>30/14 (High Speed/Normal Speed)</td> </tr> <tr> <td>0101</td> <td>46/14 (High Speed/Normal Speed)</td> </tr> <tr> <td>0110</td> <td>62/14 (High Speed/Normal Speed)</td> </tr> <tr> <td>others</td> <td>62/14 (High Speed/Normal Speed)</td> </tr> </tbody> </table>	RFITL	INTR_RDA Trigger Level (Bytes)	0000	01	0001	04	0010	08	0011	14	0100	30/14 (High Speed/Normal Speed)	0101	46/14 (High Speed/Normal Speed)	0110	62/14 (High Speed/Normal Speed)	others	62/14 (High Speed/Normal Speed)
		RFITL	INTR_RDA Trigger Level (Bytes)																	
		0000	01																	
		0001	04																	
		0010	08																	
		0011	14																	
		0100	30/14 (High Speed/Normal Speed)																	
		0101	46/14 (High Speed/Normal Speed)																	
		0110	62/14 (High Speed/Normal Speed)																	
others	62/14 (High Speed/Normal Speed)																			
[3]	Reserved	Reserved																		
[2]	TFR	TX Field Software Reset When TX_RST is set, all the byte in the transmit FIFO and TX internal state machine are cleared. 1 = Writing 1 to this bit will reset the TX internal state machine and pointers. 0 = Writing 0 to this bit has no effect. Note: This bit will auto clear needs at least 3 UART engine clock cycles.																		
[1]	RFR	RX Field Software Reset When RX_RST is set, all the byte in the receiver FIFO and RX internal state machine are cleared. 1 = Writing 1 to this bit will reset the RX internal state machine and pointers. 0 = Writing 0 to this bit has no effect. Note: This bit will auto clear needs at least 3 UART engine clock cycles.																		
[0]	Reserved	Reserved																		



Line Control Register (UA_LCR)

Register	Offset	R/W	Description	Reset Value
UA_LCR	UART0_BA+0x0C UART1_BA+0x0C UART2_BA+0x0C	R/W	UART Line Control Register	0x0000_0000

31	30	29	28	27	26	25	24
Reserved							
23	22	21	20	19	18	17	16
Reserved							
15	14	13	12	11	10	9	8
Reserved							
7	6	5	4	3	2	1	0
Reserved	BCB	SPE	EPE	PBE	NSB	WLS	

Bits	Description	
[31:7]	Reserved	Reserved
[6]	BCB	Break Control Bit When this bit is set to logic 1, the serial data output (TX) is forced to the Spacing State (logic 0). This bit acts only on TX and has no effect on the transmitter logic.
[5]	SPE	Stick Parity Enable 1 = If bit 3 and 4 are logic 1, the parity bit is transmitted and checked as logic 0. If bit 3 is 1 and bit 4 is 0 then the parity bit is transmitted and checked as 1 0 = Stick parity Disabled
[4]	EPE	Even Parity Enable 1 = Even number of logic 1's is transmitted and checked in each word 0 = Odd number of logic 1's is transmitted and checked in each word This bit has effect only when bit 3 (parity bit enable) is set.
[3]	PBE	Parity Bit Enable 1 = Parity bit is generated on each outgoing character and is checked on each incoming data. 0 = No parity bit.
[2]	NSB	Number of "STOP bit" 1 = 2 STOP bits (1.5 STOP bits if WLS[1:0]=00) 0 = 1 STOP bit.
[1:0]	WLS	Word Length Select
	WLS[1:0]	Character Length



		00	5-bit
		01	6-bit
		10	7-bit
		11	8-bit



MODEM Control Register (UA_MCR) (not available in UART2 channel)

Register	Offset	R/W	Description	Reset Value
UA_MCR	UART0_BA+0x10	R/W	UART Modem Control Register UART2: Reserved	0x0000_0200
	UART1_BA+0x10			
	UART2_BA+0x10			

31	30	29	28	27	26	25	24
Reserved							
23	22	21	20	19	18	17	16
Reserved							
15	14	13	12	11	10	9	8
Reserved		RTS_ST	Reserved			LEV_RTS	Reserved
7	6	5	4	3	2	1	0
Reserved						RTS	Reserved

Bits	Description	
[31:14]	Reserved	Reserved
[13]	RTS_ST	RTS Pin State (Read Only) (Not Available in UART2 Channel) This bit is the output pin status of RTS.
[12:10]	Reserved	Reserved

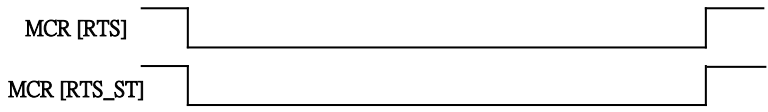
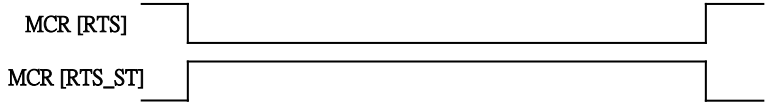
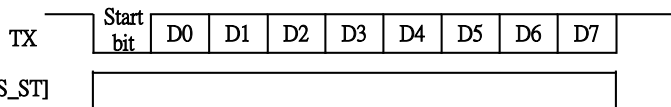
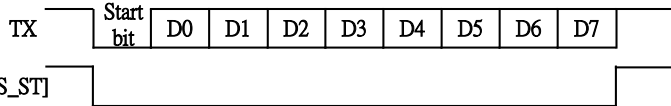

[9]	LEV_RTS	<p>RTS Trigger Level (Not Available in UART2 Channel)</p> <p>This bit can change the RTS trigger level. 1= high level triggered 0= low level triggered</p> <p><i>UART Mode : MCR[LEV_RTS]=1</i></p>  <p><i>UART Mode : MCR[LEV_RTS]=0</i></p>  <p><i>RS-485 Mode : MCR[LEV_RTS]=1</i></p>  <p><i>RS-485 Mode : MCR[LEV_RTS]=0</i></p> 
[8:2]	Reserved	Reserved
[1]	RTS	<p>RTS (Request-To-Send) Signal (Not Available in UART2 Channel)</p> <p>0 = Drive RTS pin to logic 1 (If the LEV_RTS set to low level triggered). 1 = Drive RTS pin to logic 0 (If the LEV_RTS set to low level triggered). 0 = Drive RTS pin to logic 0 (If the LEV_RTS set to high level triggered). 1 = Drive RTS pin to logic 1 (If the LEV_RTS set to high level triggered).</p>
[0]	Reserved	Reserved



Modem Status Register (UA_MSR) (not available in UART2 channel)

Register	Offset	R/W	Description	Reset Value
UA_MSR	UART0_BA+0x14 UART1_BA+0x14 UART2_BA+0x14	R/W	UART Modem Status Register UART2: Reserved	0x0000_0110

31	30	29	28	27	26	25	24
Reserved							
23	22	21	20	19	18	17	16
Reserved							
15	14	13	12	11	10	9	8
Reserved							LEV_CTS
7	6	5	4	3	2	1	0
Reserved			CTS_ST	Reserved			DCTS_F

Bits	Description	
[31:9]	Reserved	Reserved
[8]	LEV_CTS	CTS Trigger Level (Not Available in UART2 Channel) This bit can change the CTS trigger level. 1= high level triggered 0= low level triggered
[7:5]	Reserved	Reserved
[4]	CTS_ST	CTS Pin Status (Read Only) (Not Available in UART2 Channel) This bit is the pin status of CTS.
[3:1]	Reserved	Reserved
[0]	DCTS_F	Detect CTS State Change Flag (Read Only) (Not Available in UART2 Channel) This bit is set whenever CTS input has change state, and it will generate Modem interrupt to CPU when UA_IER [MODEM_IEN] is set to 1. Software can write 1 to clear this bit to 0



FIFO Status Register (UA_FSR)

Register	Offset	R/W	Description	Reset Value
UA_FSR	UART0_BA+0x18 UART1_BA+0x18 UART2_BA+0x18	R/W	UART FIFO Status Register	0x1040_4000

31	30	29	28	27	26	25	24
Reserved			TE_FLAG	Reserved			TX_OVER_IF
23	22	21	20	19	18	17	16
TX_FULL	TX_EMPTY	TX_POINTER					
15	14	13	12	11	10	9	8
RX_FULL	RX_EMPTY	RX_POINTER					
7	6	5	4	3	2	1	0
Reserved	BIF	FEF	PEF	RS485_ADD_DET	Reserved		RX_OVER_IF

Bits	Description	
[31:29]	Reserved	Reserved
[28]	TE_FLAG	<p>Transmitter Empty Flag (Read Only)</p> <p>Bit is set by hardware when TX FIFO (UA_THR) is empty and the STOP bit of the last byte has been transmitted.</p> <p>Bit is cleared automatically when TX FIFO is not empty or the last byte transmission has not completed.</p>
[27:25]	Reserved	Reserved
[24]	TX_OVER_IF	<p>TX Overflow Error Interrupt Flag (Read Only)</p> <p>If TX FIFO (UA_THR) is full, an additional write to UA_THR will cause this bit to logic 1.</p> <p>Note: This bit is read only, but can be cleared by writing '1' to it.</p>
[23]	TX_FULL	<p>Transmitter FIFO Full (Read Only)</p> <p>This bit indicates TX FIFO full or not.</p> <p>This bit is set when the number of usage in TX FIFO Buffer is equal to 64/16/16(UART0/UART1/UART2), otherwise is cleared by hardware.</p>
[22]	TX_EMPTY	<p>Transmitter FIFO Empty (Read Only)</p> <p>This bit indicates TX FIFO empty or not.</p> <p>When the last byte of TX FIFO has been transferred to Transmitter Shift Register, hardware sets this bit high. It will be cleared when writing data into THR (TX FIFO not empty).</p>
[21:16]	TX_POINTER	<p>TX FIFO Pointer (Read Only)</p> <p>This field indicates the TX FIFO Buffer Pointer. When CPU writes one byte into</p>



		<p>UA_THR, TX_POINTER increases one. When one byte of TX FIFO is transferred to Transmitter Shift Register, TX_POINTER decreases one.</p> <p>The Maximum value shows in TX_POINTER is 63/15/15 (UART0/UART1/UART2). When the using level of TX FIFO Buffer equal to 64/16/16, the TX_FULL bit is set to 1 and TX_POINTER will show 0. As one byte of TX FIFO is transferred to Transmitter Shift Register, the TX_FULL bit is clear to 0 and TX_POINTER will show 63/15/15 (UART0/UART1/UART2).</p>
[15]	RX_FULL	<p>Receiver FIFO Full (Read Only)</p> <p>This bit initiates RX FIFO full or not.</p> <p>This bit is set when the number of usage in RX FIFO Buffer is equal to 64/16/16(UART0/UART1/UART2); otherwise, it is cleared by hardware.</p>
[14]	RX_EMPTY	<p>Receiver FIFO Empty (Read Only)</p> <p>This bit initiate RX FIFO empty or not.</p> <p>When the last byte of RX FIFO has been read by CPU, hardware sets this bit high. It will be cleared when UART receives any new data.</p>
[13:8]	RX_POINTER	<p>RX FIFO Pointer (Read Only)</p> <p>This field indicates the RX FIFO Buffer Pointer. When UART receives one byte from external device, RX_POINTER increases one. When one byte of RX FIFO is read by CPU, RX_POINTER decreases one.</p> <p>The Maximum value shows in RX_POINTER is 63/15/15 (UART0/UART1/UART2). When the using level of RX FIFO Buffer equal to 64/16/16, the RX_FULL bit is set to 1 and RX_POINTER will show 0. As one byte of RX FIFO is read by CPU, the RX_FULL bit is clear to 0 and RX_POINTER will show 63/15/15 (UART0/UART1/UART2).</p>
[7]	Reserved	Reserved
[6]	BIF	<p>Break Interrupt Flag (Read Only)</p> <p>This bit is set to a logic 1 whenever the received data input(RX) is held in the "spacing state" (logic 0) for longer than a full word transmission time (that is, the total time of "start bit" + data bits + parity + stop bits) and is reset whenever the CPU writes 1 to this bit.</p> <p>Note: This bit is read only, but can be cleared by writing '1' to it.</p>
[5]	FEF	<p>Framing Error Flag (Read Only)</p> <p>This bit is set to logic 1 whenever the received character does not have a valid "stop bit" (that is, the stop bit following the last data bit or parity bit is detected as a logic 0), and is reset whenever the CPU writes 1 to this bit.</p> <p>Note: This bit is read only, but can be cleared by writing '1' to it.</p>
[4]	PEF	<p>Parity Error Flag (Read Only)</p> <p>This bit is set to logic 1 whenever the received character does not have a valid "parity bit", and is reset whenever the CPU writes 1 to this bit.</p> <p>Note: This bit is read only, but can be cleared by writing '1' to it.</p>
[3]	RS485_ADD_DET	<p>RS-485 Address Byte Detection Flag (Read Only)</p> <p>This bit is set to logic 1 and set UA_ALT_CSR [RS-485_ADD_EN] whenever in RS-485 mode the receiver detect any address byte received address byte character (bit9 = '1') bit", and it is reset whenever the CPU writes 1 to this bit.</p> <p>Note: This field is used for RS-485 function mode.</p> <p>Note: This bit is read only, but can be cleared by writing '1' to it.</p>
[2:1]	Reserved	Reserved
[0]	RX_OVER_IF	RX Overflow Error IF (Read Only)



		<p>This bit is set when RX FIFO overflow.</p> <p>If the number of bytes of received data is greater than RX_FIFO (UA_RBR) size, 64/16 bytes of UART0/UART1, this bit will be set.</p> <p>Note: This bit is read only, but can be cleared by writing '1' to it.</p>
--	--	---



Interrupt Status Control Register (UA_ISR)

Register	Offset	R/W	Description	Reset Value
UA_ISR	UART0_BA+0x1C UART1_BA+0x1C UART2_BA+0x1C	R/W	UART Interrupt Status Register	0x0000_0002

31	30	29	28	27	26	25	24
Reserved		HW_BUF_ERR_INT	HW_TOUT_INT	HW_MODEM_INT	HW_RLS_INT	Reserved	
23	22	21	20	19	18	17	16
Reserved		HW_BUF_ERR_IF	HW_TOUT_IF	HW_MODEM_IF	HW_RLS_IF	Reserved	
15	14	13	12	11	10	9	8
LIN_RX_BRE AK_INT	Reserved	BUF_ERR_INT	TOUT_INT	MODEM_INT	RLS_INT	THRE_INT	RDA_INT
7	6	5	4	3	2	1	0
LIN_RX_BRE AK_IF	Reserved	BUF_ERR_IF	TOUT_IF	MODEM_IF	RLS_IF	THRE_IF	RDA_IF

Bits	Description	
[31:30]	Reserved	Reserved
[29]	HW_BUF_ERR_INT	In DMA Mode, Buffer Error Interrupt Indicator (Read Only) This bit is set if BUF_ERR_IEN and HW_BUF_ERR_IF are both set to 1. 1 = The buffer error interrupt is generated in DMA mode 0 = No buffer error interrupt is generated in DMA mode
[28]	HW_TOUT_INT	In DMA Mode, Time Out Interrupt Indicator (Read Only) This bit is set if TOUT_IEN and HW_TOUT_IF are both set to 1. 1 = Tout interrupt is generated in DMA mode 0 = No Tout interrupt is generated in DMA mode
[27]	HW_MODEM_INT	In DMA Mode, MODEM Status Interrupt Indicator (Read Only) (Not Available in UART2 Channel) This bit is set if MODEM_IEN and HW_MODEM_IF are both set to 1. 1 = Modem interrupt is generated in DMA mode 0 = No Modem interrupt is generated in DMA mode
[26]	HW_RLS_INT	In DMA Mode, Receive Line Status Interrupt Indicator (Read Only) This bit is set if RLS_IEN and HW_RLS_IF are both set to 1. 1 = RLS interrupt is generated in DMA mode 0 = No RLS interrupt is generated in DMA mode
[25:22]	Reserved	Reserved



[21]	HW_BUF_ERR_IF	<p>In DMA Mode, Buffer Error Interrupt Flag (Read Only)</p> <p>This bit is set when the TX or RX FIFO overflows (TX_OVER_IF or RX_OVER_IF is set). When BUF_ERR_IF is set, the transfer maybe is not correct. If UA_IER [BUF_ERR_IEN] is enabled, the buffer error interrupt will be generated.</p> <p>Note: This bit is cleared when both TX_OVER_IF and RX_OVER_IF are cleared.</p>
[20]	HW_TOUT_IF	<p>In DMA Mode, Time Out Interrupt Flag (Read Only)</p> <p>This bit is set when the RX FIFO is not empty and no activities occurred in the RX FIFO and the time out counter equal to TOIC. If UA_IER [TOUT_IEN] is enabled, the Tout interrupt will be generated.</p> <p>Note: This bit is read only and user can read UA_RBR (RX is in active) to clear it.</p>
[19]	HW_MODEM_IF	<p>In DMA Mode, MODEM Interrupt Flag (Read Only) (Not Available in UART2 Channel)</p> <p>This bit is set when the CTS pin has state change (DCTS=1). If UA_IER [MODEM_IEN] is enabled, the Modem interrupt will be generated.</p> <p>Note: This bit is read only and reset to 0 when bit DCTS is cleared by a write 1 on DCTS.</p>
[18]	HW_RLS_IF	<p>In DMA Mode, Receive Line Status Flag (Read Only)</p> <p>This bit is set when the RX receive data have parity error, framing error or break error (at least one of 3 bits, BIF, FEF and PEF, is set). If UA_IER [RLS_IEN] is enabled, the RLS interrupt will be generated.</p> <p>Note: In RS-485 Function mode, this field includes "receiver detect any address byte received address byte character (bit9 = '1') bit".</p> <p>Note: This bit is read only and reset to 0 when all bits of BIF, FEF and PEF are cleared.</p>
[17:16]	Reserved	Reserved
[15]	LIN_RX_BREAK_INT	<p>LIN Bus RX Break Field Detected Interrupt Indicator (Read Only)</p> <p>This bit is set if LIN_RX_BRK_IEN and LIN_RX_BREAK_IF are both set to 1.</p> <p>1 = LIN RX Break interrupt is generated</p> <p>0 = No LIN RX Break interrupt is generated</p>
[14]	Reserved	Reserved
[13]	BUF_ERR_INT	<p>Buffer Error Interrupt Indicator (Read Only)</p> <p>This bit is set if BUF_ERR_IEN and BUF_ERR_IF are both set to 1.</p> <p>1 = The buffer error interrupt is generated</p> <p>0 = No buffer error interrupt is generated</p>
[12]	TOUT_INT	<p>Time Out Interrupt Indicator (Read Only)</p> <p>This bit is set if TOUT_IEN and TOUT_IF are both set to 1.</p> <p>1 = Tout interrupt is generated</p> <p>0 = No Tout interrupt is generated</p>
[11]	MODEM_INT	<p>MODEM Status Interrupt Indicator (Read Only) (Not Available in UART2 Channel)</p> <p>This bit is set if MODEM_IEN and MODEM_IF are both set to 1.</p> <p>1 = Modem interrupt is generated</p> <p>0 = No Modem interrupt is generated</p>
[10]	RLS_INT	<p>Receive Line Status Interrupt Indicator (Read Only).</p> <p>This bit is set if RLS_IEN and RLS_IF are both set to 1.</p>



		<p>1 = RLS interrupt is generated 0 = No RLS interrupt is generated</p>
[9]	THRE_INT	<p>Transmit Holding Register Empty Interrupt Indicator (Read Only). This bit is set if THRE_IEN and THRE_IF are both set to 1. 1 = THRE interrupt is generated 0 = No THRE interrupt is generated</p>
[8]	RDA_INT	<p>Receive Data Available Interrupt Indicator (Read Only). This bit is set if RDA_IEN and RDA_IF are both set to 1. 1 = RDA interrupt is generated 0 = No RDA interrupt is generated</p>
[7]	LIN_RX_BREAK_IF	<p>LIN Bus RX Break Field Detected Flag (Read Only) This bit is set when RX received LIN Break Field. If UA_IER [LIN_RX_BRK_IEN] is enabled the LIN RX Break interrupt will be generated. Note: This bit is read only, but can be cleared by writing '1' to it.</p>
[6]	Reserved	Reserved
[5]	BUF_ERR_IF	<p>Buffer Error Interrupt Flag (Read Only) This bit is set when the TX or RX FIFO overflows or Break Interrupt Flag or Parity Error Flag or Frame Error Flag (TX_OVER_IF or RX_OVER_IF or BIF or PEF or FEF) is set. When BUF_ERR_IF is set, the transfer is not correct. If UA_IER [BUF_ERR_IEN] is enabled, the buffer error interrupt will be generated.</p>
[4]	TOUT_IF	<p>Time Out Interrupt Flag (Read Only) This bit is set when the RX FIFO is not empty and no activities occurred in the RX FIFO and the time out counter equal to TOIC. If UA_IER [TOUT_IEN] is enabled, the Tout interrupt will be generated. Note: This bit is read only and user can read UA_RBR (RX is in active) to clear it.</p>
[3]	MODEM_IF	<p>MODEM Interrupt Flag (Read Only) (Not Available in UART2 Channel) This bit is set when the CTS pin has state change (DCTS=1). If UA_IER [MODEM_IEN] is enabled, the Modem interrupt will be generated. Note: This bit is read only and reset to 0 when bit DCTS is cleared by a write 1 on DCTS.</p>
[2]	RLS_IF	<p>Receive Line Interrupt Flag (Read Only). This bit is set when the RX receive data have parity error, framing error or break error (at least one of 3 bits, BIF, FEF and PEF, is set). If UA_IER [RLS_IEN] is enabled, the RLS interrupt will be generated. Note: In RS-485 Function mode, this field include "receiver detect any address byte received address byte character (bit9 = '1') bit". Note: This bit is read only and reset to 0 when all bits of BIF, FEF and PEF are cleared.</p>
[1]	THRE_IF	<p>Transmit Holding Register Empty Interrupt Flag (Read Only). This bit is set when the last data of TX FIFO is transferred to Transmitter Shift Register. If UA_IER [THRE_IEN] is enabled, the THRE interrupt will be generated. Note: This bit is read only and it will be cleared when writing data into THR (TX FIFO not empty).</p>
[0]	RDA_IF	<p>Receive Data Available Interrupt Flag (Read Only). When the number of bytes in the RX FIFO equals the RFITL then the RDA_IF will be set. If UA_IER [RDA_IEN] is enabled, the RDA interrupt will be generated.</p>



		Note: This bit is read only and it will be cleared when the number of unread bytes of RX FIFO drops below the threshold level (RFITL).
--	--	---



UART Interrupt Source	Interrupt Enable Bit	Interrupt Indicator to Interrupt Controller	Interrupt Flag	Flag Cleared by
Buffer Error Interrupt INT_BUF_ERR	BUF_ERR_IEN	HW_BUF_ERR_INT	HW_BUF_ERR_IF = (TX_OVER_IF or RX_OVER_IF or BIF or PEF or FEF)	Writing '1' to UA_FCR [RFR]
RX Timeout Interrupt INT_TOUT	RTO_IEN	HW_TOUT_INT	HW_TOUT_IF	Read UA_RBR
Modem Status Interrupt INT_MODEM	MODEM_IEN	HW_MODEM_INT	HW_MODEM_IF = (DCTSIF)	Write '1' to DCTSIF
Receive Line Status Interrupt INT_RLS	RLS_IEN	HW_RLS_INT	HW_RLS_IF = (BIF or FEF or PEF or RS-485_ADD_DETF)	Writing '1' to UA_FCR [RFR]
Transmit Holding Register Empty Interrupt INT_THRE	THRE_IEN	HW_THRE_INT	HW_THRE_IF	Write UA_THR
Receive Data Available Interrupt INT_RDA	RDA_IEN	HW_RDA_INT	HW_RDA_IF	Read UA_RBR

Table 5-11 UART Interrupt Sources and Flags Table in DMA Mode

UART Interrupt Source	Interrupt Enable Bit	Interrupt Indicator to Interrupt Controller	Interrupt Flag	Flag Cleared by
LIN RX Break Field Detected interrupt	LIN_RX_BRK_IEN	LIN_RX_BREAK_INT	LIN_RX_BREAK_IF	Write '1' to LIN_RX_BREAK_IF
Buffer Error Interrupt INT_BUF_ERR	BUF_ERR_IEN	BUF_ERR_INT	BUF_ERR_IF = (TX_OVER_IF or RX_OVER_IF or BIF or PEF or FEF)	Writing '1' to UA_FCR [RFR]
RX Timeout Interrupt INT_TOUT	RTO_IEN	TOUT_INT	TOUT_IF	Read UA_RBR
Modem Status Interrupt INT_MODEM	MODEM_IEN	MODEM_INT	MODEM_IF = (DCTSIF)	Write '1' to DCTSIF
Receive Line Status Interrupt INT_RLS	RLS_IEN	RLS_INT	RLS_IF = (BIF or FEF or PEF or RS-485_ADD_DETF)	Writing '1' to UA_FCR [RFR]
Transmit Holding Register Empty Interrupt INT_THRE	THRE_IEN	THRE_INT	THRE_IF	Write UA_THR
Receive Data Available Interrupt INT_RDA	RDA_IEN	RDA_INT	RDA_IF	Read UA_RBR

Table 5-12 UART Interrupt Sources and Flags Table in Software Mode



Time out Register (UA_TOR)

Register	Offset	R/W	Description	Reset Value
UA_TOR	UART0_BA+0x20 UART1_BA+0x20 UART2_BA+0x20	R/W	UART Time Out Register	0x0000_0000

31	30	29	28	27	26	25	24
Reserved							
23	22	21	20	19	18	17	16
Reserved							
15	14	13	12	11	10	9	8
DLY							
7	6	5	4	3	2	1	0
TOIC							

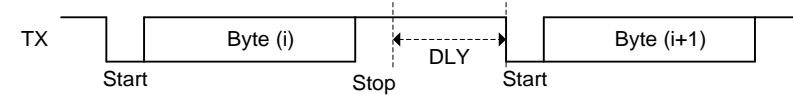
Bits	Description
[31:16]	Reserved
[15:8]	<p>DLY</p> <p>TX Delay Time Value</p> <p>This field is use to programming the transfer delay time between the last stop bit and next start bit.</p> 
[7:0]	<p>TOIC</p> <p>Time Out Interrupt Comparator</p> <p>The time out counter resets and starts counting (the counting clock = baud rate) whenever the RX FIFO receives a new data word. Once the content of time out counter (TOUT_CNT) is equal to that of time out interrupt comparator (TOIC), a receiver time out interrupt (INT_TOUT) is generated if UA_IER [RTO_IEN]. A new incoming data word or RX FIFO empty clears INT_TOUT. In order to avoid receiver time out interrupt generation immediately during one character is being received, TOIC value should be set between 40 and 255. So, for example, if TOIC is set with 40, the time out interrupt is generated after four characters are not received when 1 stop bit and no parity check is set for UART transfer.</p>



Baud Rate Divider Register (UA_BAUD)

Register	Offset	R/W	Description	Reset Value
UA_BAUD	UART0_BA+0x24 UART1_BA+0x24 UART2_BA+0x24	R/W	UART Baud Rate Divisor Register	0x0F00_0000

31	30	29	28	27	26	25	24
Reserved		DIV_X_EN	DIV_X_ONE	DIVIDER_X			
23	22	21	20	19	18	17	16
Reserved							
15	14	13	12	11	10	9	8
BRD							
7	6	5	4	3	2	1	0
BRD							

Bits	Description	
[31:30]	Reserved	Reserved
[29]	DIV_X_EN	<p>Divider X Enable</p> <p>The BRD = Baud Rate Divider, and the baud rate equation is $\text{Baud Rate} = \text{Clock} / [M * (\text{BRD} + 2)]$; The default value of M is 16.</p> <p>1 = Divider X Enabled (the equation of $M = X+1$, but DIVIDER_X [27:24] must ≥ 8).</p> <p>0 = Divider X Disabled (the equation of $M = 16$)</p> <p>Refer to the table below for more information.</p> <p>Note: In IrDA mode, this bit must be disabled.</p>
[28]	DIV_X_ONE	<p>Divider X equal 1</p> <p>1 = Divider M = 1 (the equation of $M = 1$, but BRD [15:0] must ≥ 3).</p> <p>0 = Divider M = X (the equation of $M = X+1$, but DIVIDER_X [27:24] must ≥ 8)</p> <p>Refer to the Table 5-13 below for more information.</p>
[27:24]	DIVIDER_X	<p>Divider X</p> <p>The baud rate divider $M = X+1$.</p>
[23:16]	Reserved	Reserved
[15:0]	BRD	<p>Baud Rate Divider</p> <p>The field indicates the baud rate divider.</p>



Mode	DIV_X_EN	DIV_X_ONE	DIVIDER X	BRD	Baud Rate Equation
0	Disable	0	B	A	$UART_CLK / [16 * (A+2)]$
1	Enable	0	B	A	$UART_CLK / [(B+1) * (A+2)]$, B must ≥ 8
2	Enable	1	Don't care	A	$UART_CLK / (A+2)$, A must ≥ 3

Table 5-13 Baud Rate Equation Table



IrDA Control Register (IRCR)

Register	Offset	R/W	Description	Reset Value
UA_IRCR	UART0_BA+0x28 UART1_BA+0x28 UART2_BA+0x28	R/W	UART IrDA Control Register	0x0000_0040

31	30	29	28	27	26	25	24
Reserved							
23	22	21	20	19	18	17	16
Reserved							
15	14	13	12	11	10	9	8
Reserved							
7	6	5	4	3	2	1	0
Reserved	INV_RX	INV_TX	Reserved			TX_SELECT	Reserved

Bits	Description	
[31:7]	Reserved	Reserved
[6]	INV_RX	INV_RX 1= Inverse RX input signal 0= No inversion
[5]	INV_TX	INV_TX 1= Inverse TX output signal 0= No inversion
[4:2]	Reserved	Reserved
[1]	TX_SELECT	TX_SELECT 1= Enable IrDA transmitter 0= Enable IrDA receiver
[0]	Reserved	Reserved

Note: In IrDA mode, the UA_BAUD [DIV_X_EN] register must be disabled (the baud equation must be Clock / 16 * (BRD))



UART Alternate Control/Status Register (UA_ALT_CSR)

Register	Offset	R/W	Description	Reset Value
UA_ALT_CSR	UART0_BA+0x2C UART1_BA+0x2C UART2_BA+0x2C	R/W	UART Alternate Control/Status Register	0x0000_0000

31	30	29	28	27	26	25	24
ADDR_MATCH							
23	22	21	20	19	18	17	16
Reserved							
15	14	13	12	11	10	9	8
RS485_ADD_EN	Reserved				RS485_AUD	RS485_AAD	RS485_NMM
7	6	5	4	3	2	1	0
LIN_TX_EN	LIN_RX_EN	Reserved		UA_LIN_BKFL			

Bits	Description	
[31:24]	ADDR_MATCH	<p>Address match value register</p> <p>This field contains the RS-485 address match values.</p> <p>Note: This field is used for RS-485 auto address detection mode.</p>
[23:16]	Reserved	Reserved
[15]	RS485_ADD_EN	<p>RS-485 Address Detection Enable</p> <p>This bit is use to enable RS-485 address detection mode.</p> <p>1 = Address detection mode Enabled 0 = Address detection mode Disabled</p> <p>Note: This field is used for RS-485 any operation mode.</p>
[14:11]	Reserved	Reserved
[10]	RS485_AUD	<p>RS-485 Auto Direction Mode (AUD)</p> <p>1 = RS-485 Auto Direction Operation Mode (AUO) Enabled 0 = RS-485 Auto Direction Operation Mode (AUO) Disabled</p> <p>Note: It can be active with RS-485_AAD or RS-485_NMM operation mode.</p>
[9]	RS485_AAD	<p>RS-485 Auto Address Detection Operation Mode (AAD)</p> <p>1 = RS-485 Auto Address Detection Operation Mode (AAD) Enabled 0 = RS-485 Auto Address Detection Operation Mode (AAD) Disabled</p> <p>Note: It cannot be active in RS-485_NMM operation mode.</p>
[8]	RS485_NMM	RS-485 Normal Multi-drop Operation Mode (NMM)



		1 = RS-485 Normal Multi-drop Operation Mode (NMM) Enabled 0 = RS-485 Normal Multi-drop Operation mode (NMM) Disabled Note: It cannot be active in RS-485_AAD operation mode.
[7]	LIN_TX_EN	LIN TX Break Mode Enable 1 = LIN TX Break mode. Enabled 0 = LIN TX Break mode. Disabled Note: When TX break field transfer operation is finished, this bit will be cleared automatically.
[6]	LIN_RX_EN	LIN RX Enable 1 = LIN RX mode Enabled. 0 = LIN RX mode Disabled.
[5:4]	Reserved	Reserved
[3:0]	UA_LIN_BKFL	UART LIN Break Field Length This field indicates a 4-bit LIN TX break field count. Note: This break field length is UA_LIN_BKFL + 2



UART Function Select Register (UA_FUN_SEL)

Register	Offset	R/W	Description	Reset Value
UA_FUN_SEL	UART0_BA+0x30 UART1_BA+0x30 UART2_BA+0x30	R/W	UART Function Select Register	0x0000_0000

31	30	29	28	27	26	25	24
Reserved							
23	22	21	20	19	18	17	16
Reserved							
15	14	13	12	11	10	9	8
Reserved							
7	6	5	4	3	2	1	0
Reserved						FUN_SEL	

Bits	Description	
[31:2]	Reserved	Reserved
[1:0]	FUN_SEL	Function Select Enable 00 = UART function 01 = LIN function Enabled 10 = IrDA function Enabled 11 = RS-485 function Enabled

5.13 Controller Area Network (CAN)

5.13.1 Overview

The C_CAN consists of the CAN Core, Message RAM, Message Handler, Control Registers and Module Interface (Refer Figure 5-76). The CAN Core performs communication according to the CAN protocol version 2.0 part A and B. The bit rate can be programmed to values up to 1MBit/s. For the connection to the physical layer, additional transceiver hardware is required.

For communication on a CAN network, individual Message Objects are configured. The Message Objects and Identifier Masks for acceptance filtering of received messages are stored in the Message RAM. All functions concerning the handling of messages are implemented in the Message Handler. These functions include acceptance filtering, the transfer of messages between the CAN Core and the Message RAM, and the handling of transmission requests as well as the generation of the module interrupt.

The register set of the C_CAN can be accessed directly by the software through the module interface. These registers are used to control/configure the CAN Core and the Message Handler and to access the Message RAM.

5.13.2 Features

- Supports CAN protocol version 2.0 part A and B
- Bit rates up to 1 MBit/s
- 32 Message Objects
- Each Message Object has its own identifier mask
- Programmable FIFO mode (concatenation of Message Objects)
- Maskable interrupt
- Disabled Automatic Re-transmission mode for Time Triggered CAN applications
- Programmable loop-back mode for self-test operation
- 16-bit module interfaces to the AMBA APB bus
- Supports wake-up function

5.13.3 Block Diagram

The C_CAN interfaces with the AMBA APB bus. Figure 5-76 shows the block diagram of the C_CAN.

- **CAN Core**

CAN Protocol Controller and Rx/Tx Shift Register for serial/parallel conversion of messages.

- **Message RAM**

Stores Message Objects and Identifier Masks

- **Registers**

All registers used to control and to configure the C_CAN.

- **Message Handler**

State Machine that controls the data transfer between the Rx/Tx Shift Register of the CAN Core and the Message RAM as well as the generation of interrupts as programmed in the Control and Configuration Registers.

- **Module Interface**

C_CAN interfaces to the AMBA APB 16-bit bus from ARM.

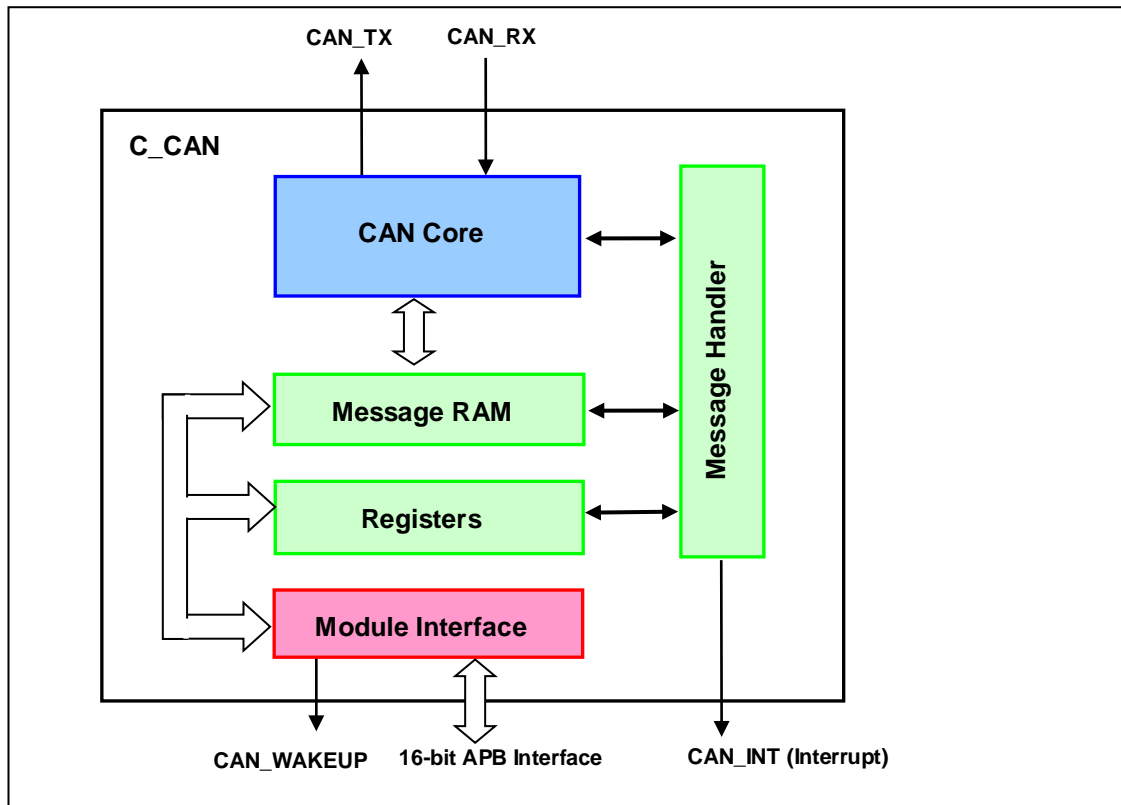

Figure 5-76 CAN Peripheral Block Diagram

5.13.4 Functional Description

5.13.4.1 Software Initialization

The software initialization is started by setting the **Init** bit in the CAN Control Register, either by a software or a hardware reset, or by going to *Bus_Off* state.

While the **Init** bit is set, all messages transfer to and from the CAN bus are stopped and the status of the **CAN_TX** output pin is recessive (HIGH). The Error Management Logic (EML) counters are unchanged. Setting the **Init** bit does not change any configuration register.

To initialize the CAN Controller, software has to set up the Bit Timing Register and each Message Object. If a Message Object is not required, the corresponding **MsgVal** bit should be cleared. Otherwise, the entire Message Object has to be initialized.

Access to the Bit Timing Register and to the Baud Rate Prescaler Extension Register for configuring bit timing is enabled when both the **Init** and **CCE** bits in the CAN Control Register are set.

Resetting the **Init** bit (by software only) finishes the software initialization. Later, the Bit Stream Processor (BSP) (see Section 5.13.6.10: Configuring the Bit Timing) synchronizes itself to the data transfer on the CAN bus by waiting for the occurrence of a sequence of 11 consecutive recessive bits (= Bus Idle) before it can take part in bus activities and start the message transfer.

The initialization of the Message Objects is independent of **Init** and can be done on the fly, but the Message Objects should all be configured to particular identifiers or set to not valid before the BSP starts the message transfer.

To change the configuration of a Message Object during normal operation, the software has to start by resetting the corresponding **MsgVal** bit. When the configuration is completed, **MsgVal** is set again.

5.13.4.2 CAN Message Transfer

Once the C_CAN is initialized and **Init** bit is reset to 0, the C_CAN Core synchronizes itself to the CAN bus and starts the message transfer.

Received messages are stored in their appropriate Message Objects if they pass the Message Handler's acceptance filtering. The whole message including all arbitration bits, DLC and eight data bytes are stored in the Message Object. If the Identifier Mask is used, the arbitration bits which are masked to "don't care" may be overwritten in the Message Object.

Software can read or write each message any time through the Interface Registers and the Message Handler guarantees data consistency in case of concurrent accesses.

Messages to be transmitted are updated by the application software. If a permanent Message Object (arbitration and control bits are set during configuration) exists for the message, only the data bytes are updated and the **TxRqst** bit with **NewDat** bit are set to start the transmission. If several transmit messages are assigned to the same Message Object (when the number of Message Objects is not sufficient), the whole Message Object has to be configured before the transmission of this message is requested.

The transmission of any number of Message Objects may be requested at the same time. Message objects are transmitted subsequently according to their internal priority. Messages may be updated or set to not valid any time, even when their requested transmission is still pending. The old data will be discarded when a message is updated before its pending transmission has started.

Depending on the configuration of the Message Object, the transmission of a message may be requested autonomously by the reception of a remote frame with a matching identifier.

5.13.4.3 Disabled Automatic Retransmission

In accordance with the CAN Specification (see ISO11898, 6.3.3 Recovery Management), the C_CAN provides means for automatic retransmission of frames that have lost arbitration or have been disturbed by errors during transmission. The frame transmission service will not be confirmed to the user before the transmission is successfully completed. This means that, by default, automatic retransmission is enabled. It can be disabled to enable the C_CAN to work within a Time Triggered CAN (TTCAN, see ISO11898-1) environment.

The Disabled Automatic Retransmission mode is enabled by setting the Disable Automatic Retransmission (**DAR**) bit in the CAN Control Register to one. In this operation mode, the programmer has to consider the different behavior of bits TxRqst and NewDat in the Control Registers of the Message Buffers:

- When a transmission starts, bit TxRqst of the respective Message Buffer is cleared, while bit NewDat remains set.
- When the transmission completed successfully, bit NewDat is cleared.
- When a transmission fails (lost arbitration or error), bit NewDat remains set.
- To restart the transmission, the software should set the bit TxRqst again.

5.13.5 Test Mode

Test Mode is entered by setting the **Test** bit in the CAN Control Register. In Test Mode, bits **Tx1**, **Tx0**, **LBack**, **Silent** and **Basic** in the Test Register are writeable. Bit **Rx** monitors the state of the **CAN_RX** pin and therefore is only readable. All Test Register functions are disabled when the Test bit is cleared.

5.13.5.1 Silent Mode

The CAN Core can be set in Silent Mode by programming the **Silent** bit in the Test Register to one. In Silent Mode, the C_CAN is able to receive valid data frames and valid remote frames, but it sends only recessive bits on the CAN bus and it cannot start a transmission. If the CAN Core is required to send a dominant bit (ACK bit, Error Frames), the bit is rerouted internally so that the CAN Core monitors this dominant bit, although the CAN bus may remain in recessive state. The Silent Mode can be used to analysis the traffic on a CAN bus without affecting it by the transmission of *dominant* bits. Figure 5-77 shows the connection of signals **CAN_TX** and **CAN_RX** to the CAN Core in Silent Mode.

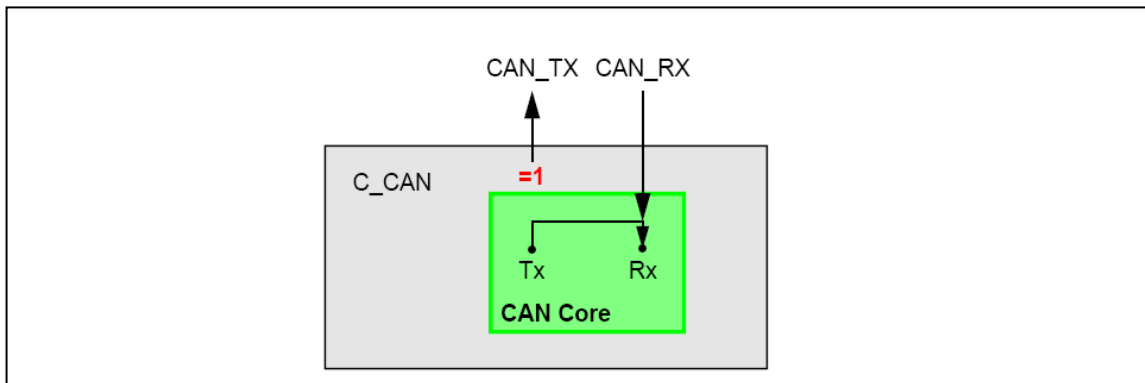

Figure 5-77 CAN Core in Silent Mode



5.13.5.2 Loop Back Mode

The CAN Core can be set in Loop Back Mode by programming the Test Register bit **LBack** to one. In Loop Back Mode, the CAN Core treats its own transmitted messages as received messages and stores them into a Receive Buffer (if they pass acceptance filtering). Figure 5-78 shows the connection of signals, **CAN_TX** and **CAN_RX**, to the CAN Core in Loop Back Mode.

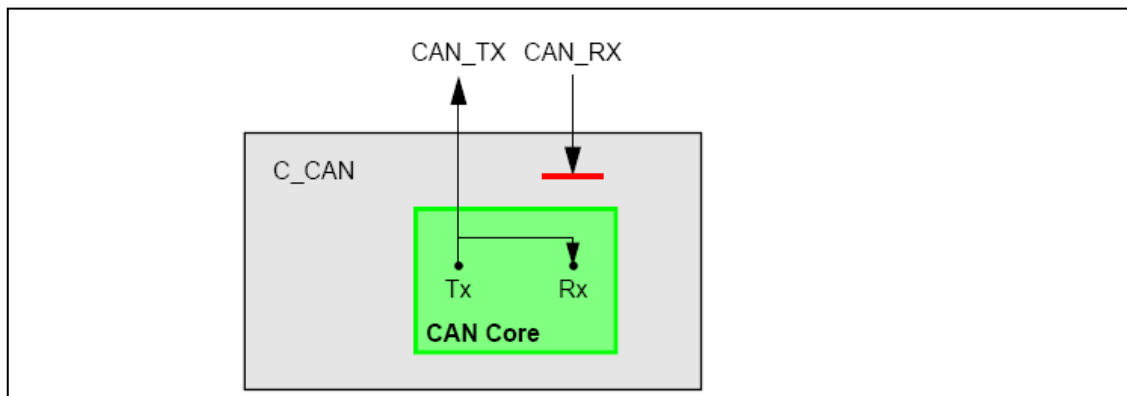

Figure 5-78 CAN Core in Loop Back Mode

This mode is provided for self-test functions. To be independent from external stimulation, the CAN Core ignores acknowledge errors (recessive bit sampled in the acknowledge slot of a data/remote frame) in Loop Back Mode. In this mode, the CAN Core performs an internal feedback from its Tx output to its Rx input. The actual value of the **CAN_RX** input pin is disregarded by the CAN Core. The transmitted messages can be monitored on the **CAN_TX** pin.

5.13.5.3 Loop Back Combined with Silent Mode

It is also possible to combine Loop Back Mode and Silent Mode by programming bits **LBack** and **Silent** to one at the same time. This mode can be used for a “Hot Selftest”, which means that C_CAN can be tested without affecting a running CAN system connected to the **CAN_TX** and **CAN_RX** pins. In this mode, the **CAN_RX** pin is disconnected from the CAN Core and the **CAN_TX** pin is held recessive. Figure 5-79 shows the connection of signals **CAN_TX** and **CAN_RX** to the CAN Core in case of the combination of Loop Back Mode with Silent Mode.

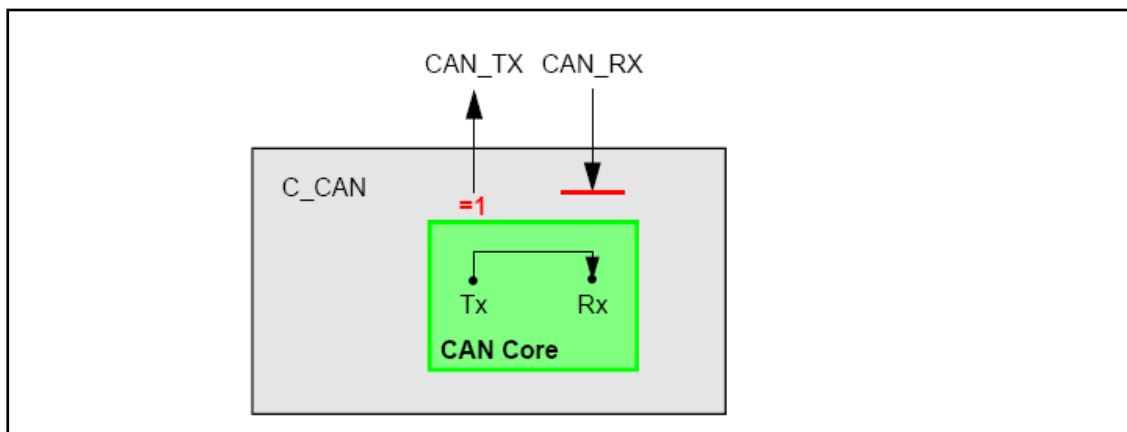

Figure 5-79 CAN Core in Loop Back Mode Combined with Silent Mode



5.13.5.4 Basic Mode

The CAN Core can be set in Basic Mode by programming the Test Register bit **Basic** to one. In this mode, the C_CAN runs without the Message RAM.

The IF1 Registers are used as Transmit Buffer. The transmission of the contents of the IF1 Registers are requested by writing the Busy bit of the IF1 Command Request Register to one. The IF1 Registers are locked while the **Busy** bit is set. The Busy bit indicates that the transmission is pending.

As soon the CAN bus is idle, the IF1 Registers are loaded into the shift register of the CAN Core and the transmission is started. When the transmission has been completed, the **Busy** bit is reset and the locked IF1 Registers are released.

A pending transmission can be aborted at any time by resetting the **Busy** bit in the IF1 Command Request Register while the IF1 Registers are locked. If the software has reset the Busy bit, a possible retransmission in case of lost arbitration or in case of an error is disabled.

The IF2 Registers are used as a Receive Buffer. After the reception of a message the contents of the shift register is stored into the IF2 Registers, without any acceptance filtering.

Additionally, the actual contents of the shift register can be monitored during the message transfer. Each time a read Message Object is initiated by writing the **Busy** bit of the IF2 Command Request Register to one, the contents of the shift register are stored into the IF2 Registers.

In Basic Mode, the evaluation of all Message Object related control and status bits and the control bits of the IFn Command Mask Registers are turned off. The message number of the Command request registers is not evaluated. The **NewDat** and **MsgLst** bits in the IF2 Message Control Register retain their function, **DLC3-0** indicates the received DLC, and the other control bits are read as '0'.

5.13.5.5 Software Control of CAN_TX Pin

Four output functions are available for the CAN transmit pin, **CAN_TX**. In addition to its default function (serial data output), the CAN transmit pin can drive the CAN Sample Point signal to monitor CAN_Core's bit timing and it can drive constant dominant or recessive values. The latter two functions, combined with the readable CAN receive pin **CAN_RX**, can be used to check the physical layer of the CAN bus.

The output mode for the **CAN_TX** pin is selected by programming the **Tx1** and **Tx0** bits of the CAN Test Register.

The three test functions of the **CAN_TX** pin interfere with all CAN protocol functions. **CAN_TX** must be left in its default function when CAN message transfer or any of the test modes (Loop Back Mode, Silent Mode, or Basic Mode) are selected.

5.13.6 CAN Communications

5.13.6.1 Managing Message Objects

The configuration of the Message Objects in the Message RAM (with the exception of the bits the CAN Control Regist **MsgVal**, **NewDat**, **IntPnd**, and **TxRqst**) will not be affected by resetting the chip. All the Message Objects must be initialized by the application software or they must be "not valid" (**MsgVal** = '0') and the bit timing must be configured before the application software clears the Init bit in ter.

The configuration of a Message Object is done by programming Mask, Arbitration, Control and Data fields of one of the two interface registers to the desired values. By writing to the corresponding IFn Command Request Register, the IFn Message Buffer Registers are loaded

into the addressed Message Object in the Message RAM.

When the Init bit in the CAN Control Register is cleared, the CAN Protocol Controller state machine of the CAN_Core and the state machine of the Message Handler control the internal data flow of the C_CAN. Received messages that pass the acceptance filtering are stored into the Message RAM, messages with pending transmission request are loaded into the CAN_Core's Shift Register and are transmitted through the CAN bus.

The application software reads received messages and updates messages to be transmitted through the IFn Interface Registers. Depending on the configuration, the application software is interrupted on certain CAN message and CAN error events.

5.13.6.2 Message Handler State Machine

The Message Handler controls the data transfer between the Rx/Tx Shift Register of the CAN Core, the Message RAM and the IFn Registers.

The Message Handler FSM controls the following functions:

- Data Transfer from IFn Registers to the Message RAM
- Data Transfer from Message RAM to the IFn Registers
- Data Transfer from Shift Register to the Message RAM
- Data Transfer from Message RAM to Shift Register
- Data Transfer from Shift Register to the Acceptance Filtering unit
- Scanning of Message RAM for a matching Message Object
- Handling of TxRqst flags
- Handling of interrupts.

5.13.6.2.1 Data Transfer from/to Message RAM

When the application software initiates a data transfer between the IFn Registers and Message RAM, the Message Handler sets the Busy bit in the respective Command Request Register (CAN_IFn_CRR) to '1'. After the transfer has completed, the Busy bit is again cleared (see Figure 5-80).

The respective Command Mask Register specifies whether a complete Message Object or only parts of it will be transferred. Due to the structure of the Message RAM, it is not possible to write single bits/bytes of one Message Object. It is always necessary to write a complete Message Object into the Message RAM. Therefore, the data transfer from the IFn Registers to the Message RAM requires a read-modify-write cycle. First, those parts of the Message Object that are not to be changed are read from the Message RAM and then the complete contents of the Message Buffer Registers are written into the Message Object.

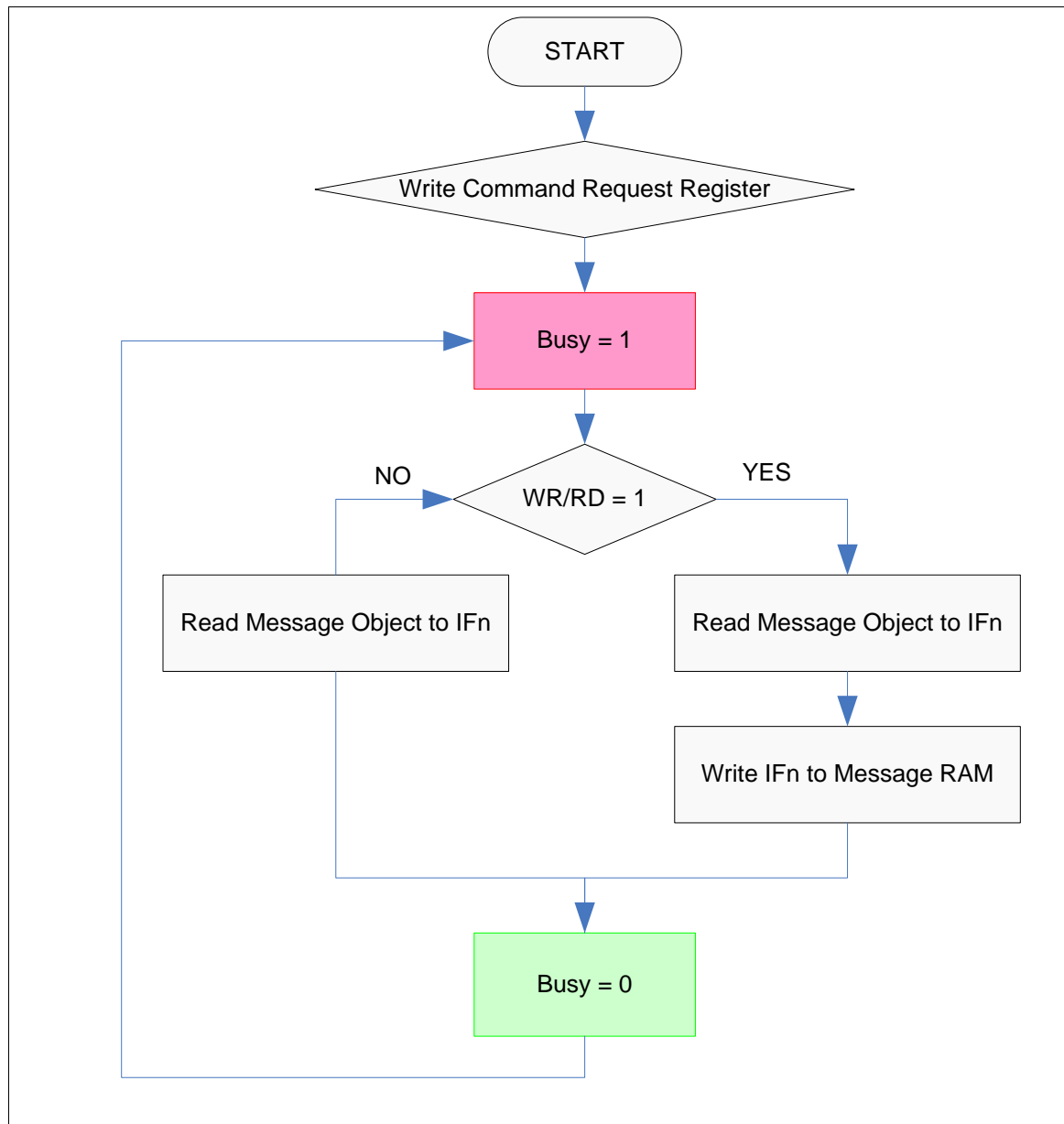

Figure 5-80 Data Transfer between IFn Registers and Message

After a partial write of a Message Object, the Message Buffer Registers that are not selected in the Command Mask Register will set the actual contents of the selected Message Object.

After a partial read of a Message Object, the Message Buffer Registers that are not selected in the Command Mask Register will be left unchanged.

5.13.6.2.2 Message Transmission

If the shift register of the CAN Core cell is ready for loading and if there is no data transfer between the IFn Registers and Message RAM, the **MsgVal** bits in the Message Valid Register and **TxRqst** bits in the Transmission Request Register are evaluated. The valid Message Object with the highest priority pending transmission request is loaded into the shift register by the Message Handler and the transmission is started. The **NewDat** bit of the Message Object is reset.

After a successful transmission and also if no new data was written to the Message Object (**NewDat** = '0') since the start of the transmission, the **TxRqst** bit of the Message Control register (CAN_IFn_MCR) will be reset. If TxIE bit of the Message Control register (CAN_IFn_MCR) is set, **IntPnd** bit of the Interrupt Identifier register will be set after a successful transmission. If the C_CAN has lost the arbitration or if an error occurred during the transmission, the message will be retransmitted as soon as the CAN bus is free again. Meanwhile, if the transmission of a message with higher priority has been requested, the messages will be transmitted in the order of their priority.

5.13.6.2.3 Acceptance Filtering of Received Messages

When the arbitration and control field (Identifier + IDE + RTR + DLC) of an incoming message is completely shifted into the Rx/Tx Shift Register of the CAN Core, the Message Handler FSM starts the scanning of the Message RAM for a matching valid Message Object.

To scan the Message RAM for a matching Message Object, the Acceptance Filtering unit is loaded with the arbitration bits from the CAN Core shift register. The arbitration and mask fields (including **MsgVal**, **UMask**, **NewDat**, and **EoB**) of Message Object 1 are then loaded into the Acceptance Filtering unit and compared with the arbitration field from the shift register. This is repeated with each following Message Object until a matching Message Object is found or until the end of the Message RAM is reached.

If a match occurs, the scan is stopped and the Message Handler FSM proceeds depending on the type of frame (Data Frame or Remote Frame) received.

Reception of Data Frame

The Message Handler FSM stores the message from the CAN Core shift register into the respective Message Object in the Message RAM. Not only the data bytes, but all arbitration bits and the Data Length Code are stored into the corresponding Message Object. This is done to keep the data bytes connected with the identifier even if arbitration mask registers are used.

The **NewDat** bit is set to indicate that new data (not yet seen by the software) has been received. The application software should reset **NewDat** bit when the Message Object has been read. If at the time of reception, the **NewDat** bit was already set, **MsgLst** is set to indicate that the previous data (supposedly not seen by the software) is lost. If the **RxIE** bit is set, the **IntPnd** bit is set, causing the Interrupt Register to point to this Message Object.

The **TxRqst** bit of this Message Object is reset to prevent the transmission of a Remote Frame, while the requested Data Frame has just been received.

Reception of Remote Frame

When a Remote Frame is received, three different configurations of the matching Message Object have to be considered:

- 1) Dir = '1' (direction = transmit), **RmtEn** = '1', **UMask** = '1' or '0'

At the reception of a matching Remote Frame, the TxRqst bit of this Message Object is set. The rest of the Message Object remains unchanged.

- 2) Dir = '1' (direction = transmit), **RmtEn** = '0', **UMask** = '0'

At the reception of a matching Remote Frame, the TxRqst bit of this Message Object remains unchanged; the Remote Frame is ignored.

- 3) Dir = '1' (direction = transmit), **RmtEn** = '0', **UMask** = '1'



At the reception of a matching Remote Frame, the **TxRqst** bit of this Message Object is reset. The arbitration and control field (Identifier + IDE + RTR + DLC) from the shift register is stored in the Message Object of the Message RAM and the **NewDat** bit of this Message Object is set. The data field of the Message Object remains unchanged; the Remote Frame is treated similar to a received Data Frame.

5.13.6.2.4 Receive/Transmit Priority

The receive/transmit priority for the Message Objects is attached to the message number. Message Object 1 has the highest priority, while Message Object 32 has the lowest priority. If more than one transmission request is pending, they are serviced due to the priority of the corresponding Message Object

5.13.6.3 Configuring a Transmit Object

Table 5-14 shows how a Transmit Object should be initialized.

Ms	Arb	Data	Mask	EoB	Dir	NewDat	MsgLst	RxIE	TxIE	IntPnd	RmtEn	TxRqst
1	appl.	appl.	appl.	1	1	0	0	0	appl.	0	appl.	0

Table 5-14 Initialization of a Transmit Object

Note: appl. = application software.

The Arbitration Register values (**ID28-0** and **Xtd** bit) are provided by the application. They define the identifier and type of the outgoing message. If an 11-bit Identifier (“Standard Frame”) is used, it is programmed to ID28 - ID18. The ID17 - ID0 can then be disregarded.

If the **TxIE** bit is set, the **IntPnd** bit will be set after a successful transmission of the Message Object.

If the **RmtEn** bit is set, a matching received Remote Frame will cause the **TxRqst** bit to be set; the Remote Frame will autonomously be answered by a Data Frame.

The Data Register values (**DLC3-0**, **Data0-7**) are provided by the application, **TxRqst** and **RmtEn** may not be set before the data is valid.

The Mask Registers (**Msk28-0**, **UMask**, **MXtd**, and **MDir** bits) may be used (**UMask**=’1’) to allow groups of Remote Frames with similar identifiers to set the **TxRqst** bit. The **Dir** bit should not be masked.

5.13.6.4 Updating a Transmit Object

The software may update the data bytes of a Transmit Object any time through the IFn Interface registers, neither **MsgVal** nor **TxRqst** have to be reset before the update.

Even if only a part of the data bytes are to be updated, all four bytes of the corresponding IFn Data A Register or IFn Data B Register have to be valid before the contents of that register are transferred to the Message Object. Either the application software has to write all four bytes into the IFn Data Register or the Message Object is transferred to the IFn Data Register before the software writes the new data bytes.



When only the (eight) data bytes are updated, first 0x0087 is written to the Command Mask Register and then the number of the Message Object is written to the Command Request Register, concurrently updating the data bytes and setting **TxRqst**.

To prevent the reset of **TxRqst** at the end of a transmission that may already be in progress while the data is updated, **NewDat** has to be set together with **TxRqst**.

When **NewDat** is set together with **TxRqst**, **NewDat** will be reset as soon as the new transmission has started.

5.13.6.5 Configuring a Receive Object

Table 5-15 shows how a Receive Object should be initialized.

MsgVal	Arb	Data	Mask	EoB	Dir	NewDat	MsgLst	RxIE	TxIE	IntPnd	RmtEn	TxRqst
1	appl.	appl.	appl.	1	0	0	0	appl.	0	0	0	0

Table 5-15 Initialization of a Receive Object

The Arbitration Registers values (**ID28-0** and **Xtd** bit) are provided by the application. They define the identifier and type of accepted received messages. If an 11-bit Identifier (“Standard Frame”) is used, it is programmed to ID28 - ID18. Then ID17 - ID0 can be disregarded. When a Data Frame with an 11-bit Identifier is received, ID17 - ID0 will be set to ‘0’.

If the **RxIE** bit is set, the **IntPnd** bit will be set when a received Data Frame is accepted and stored in the Message Object.

The Data Length Code (DLC3-0) is provided by the application. When the Message Handler stores a Data Frame in the Message Object, it will store the received Data Length Code and eight data bytes. If the Data Length Code is less than 8, the remaining bytes of the Message Object will be overwritten by unspecified values.

The Mask Registers (Msk28-0, **UMask**, **MXtd**, and **MDir** bits) may be used (**UMask**=‘1’) to allow groups of Data Frames with similar identifiers to be accepted. The Dir bit should not be masked in typical applications.

5.13.6.6 Handling Received Messages

The application software may read a received message any time through the IFn Interface registers. The data consistency is guaranteed by the Message Handler state machine.

Typically, the software will write first 0x007F to the Command Mask Register and then the number of the Message Object to the Command Request Register. This combination will transfer the whole received message from the Message RAM into the Message Buffer Register. Additionally, the bits **NewDat** and **IntPnd** are cleared in the Message RAM (not in the Message Buffer).

If the Message Object uses masks for acceptance filtering, the arbitration bits shows which of the matching messages have been received.

The actual value of **NewDat** shows whether a new message has been received since the last



time this Message Object was read. The actual value of **MsgLst** shows whether more than one message has been received since the last time this Message Object was read. **MsgLst** will not be automatically reset.

By means of a Remote Frame, the software may request another CAN node to provide new data for a receive object. Setting the **TxRqst** bit of a receive object will cause the transmission of a Remote Frame with the receive object's identifier. This Remote Frame triggers the other CAN node to start the transmission of the matching Data Frame. If the matching Data Frame is received before the Remote Frame could be transmitted, the **TxRqst** bit is automatically reset.

5.13.6.7 Configuring a FIFO Buffer

With the exception of the EoB bit, the configuration of Receive Objects belonging to a FIFO Buffer is the same as the configuration of a (single) Receive Object, see Section 5.13.6.5: Configuring a Receive Object.

To concatenate two or more Message Objects into a FIFO Buffer, the identifiers and masks (if used) of these Message Objects have to be programmed to matching values. Due to the implicit priority of the Message Objects, the Message Object with the lowest number will be the first Message Object of the FIFO Buffer. The **EoB** bit of all Message Objects of a FIFO Buffer except the last have to be programmed to zero. The **EoB** bits of the last Message Object of a FIFO Buffer is set to one, configuring it as the End of the Block.

5.13.6.8 Receiving Messages with FIFO Buffers

Received messages with identifiers matching to a FIFO Buffer are stored into a Message Object of this FIFO Buffer starting with the Message Object with the lowest message number.

When a message is stored into a Message Object of a FIFO Buffer, the **NewDat** bit of this Message Object is set. By setting **NewDat** while **EoB** is zero, the Message Object is locked for further write access by the Message Handler until the application software has written the **NewDat** bit back to 0.

Messages are stored into a FIFO Buffer until the last Message Object of this FIFO Buffer is reached. If none of the preceding Message Objects is released by writing **NewDat** to 0, all further messages for this FIFO Buffer will be written into the last Message Object of the FIFO Buffer and therefore overwrite previous messages.

5.13.6.8.1 Reading from a FIFO Buffer

When the application software transfers the contents of a Message Object to the IFn Message Buffer register by writing its number to the IFn Command Request Register, the corresponding Command Mask Register should be programmed in such a way that bits **NewDat** and **IntPnd** are reset to 0 (**TxRqst/NewDat** = '1' and **ClrIntPnd** = '1'). The values of these bits in the Message Control Register always reflect the status before resetting the bits.

To assure the correct function of a FIFO Buffer, the application software should read the Message Objects starting at the FIFO Object with the lowest message number.

Figure 5-81 shows how a set of Message Objects which are concatenated to a FIFO Buffer can be handled by the application software.

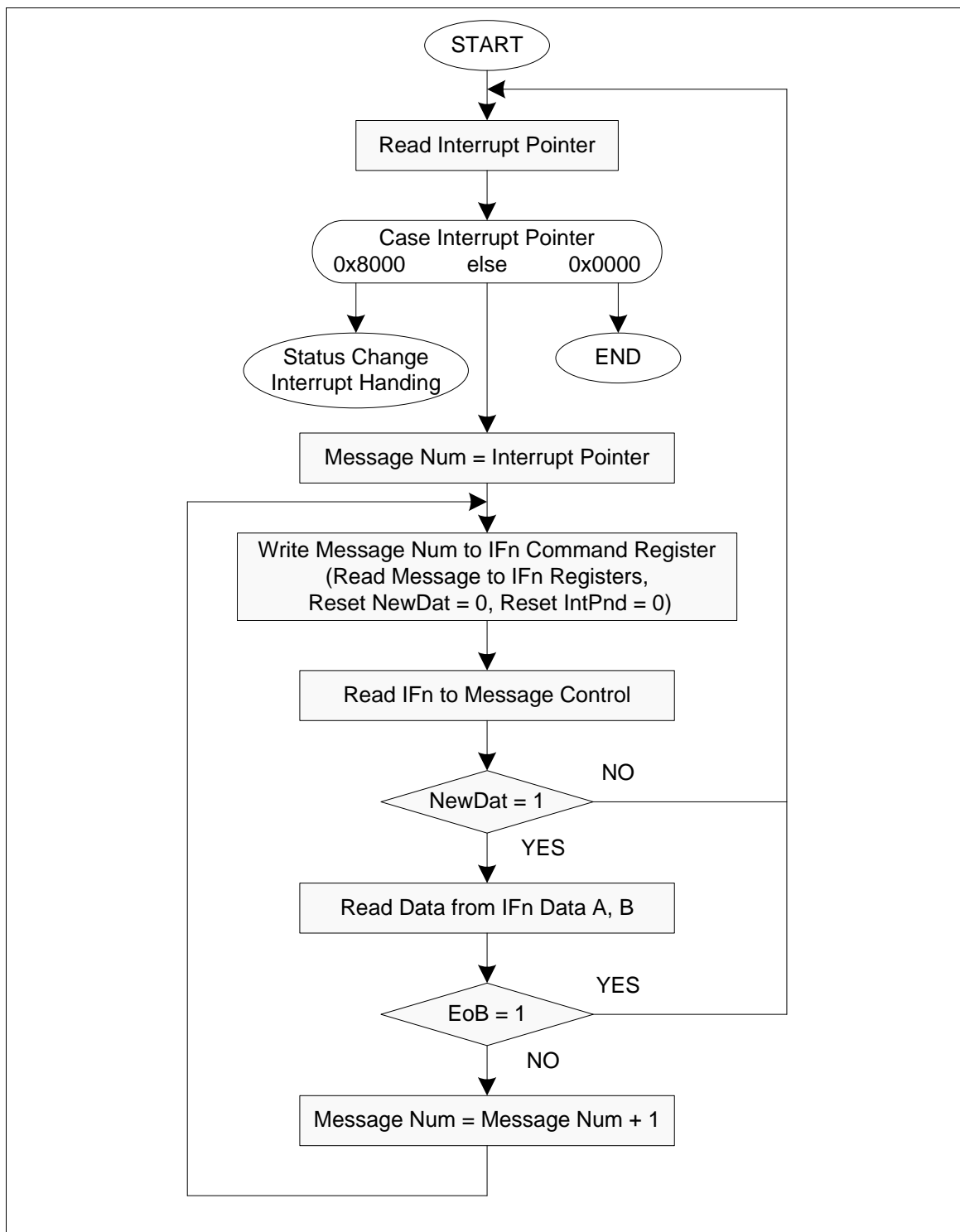

Figure 5-81 Application Software Handling of a FIFO Buffer



5.13.6.9 Handling Interrupts

If several interrupts are pending, the CAN Interrupt Register will point to the pending interrupt with the highest priority, disregarding their chronological order. An interrupt remains pending until the application software has cleared it.

The Status Interrupt has the highest priority. Among the message interrupts, interrupt priority of the Message Object decreases with increasing message number.

A message interrupt is cleared by clearing the **IntPnd** bit of the Message Object. The Status Interrupt is cleared by reading the Status Register.

The interrupt identifier, **IntId**, in the Interrupt Register, indicates the cause of the interrupt. When no interrupt is pending, the register will hold the value zero. If the value of the Interrupt Register is different from zero, then there is an interrupt pending and, if IE is set, the CAN_INT interrupt signal is active. The interrupt remains active until the Interrupt Register is back to value zero (the cause of the interrupt is reset) or until IE is reset.

The value 0x8000 indicates that an interrupt is pending because the CAN Core has updated (not necessarily changed) the Status Register (Error Interrupt or Status Interrupt). This interrupt has the highest priority. The application software can update (reset) the status bits **RxOk**, **TxOk** and **LEC**, but a write access of the software to the Status Register can never generate or reset an interrupt.

All other values indicate that the source of the interrupt is one of the Message Objects. **IntId** points to the pending message interrupt with the highest interrupt priority.

The application software controls whether a change of the Status Register may cause an interrupt (bits **EIE** and **SIE** in the CAN Control Register) and whether the interrupt line becomes active when the Interrupt Register is different from zero (bit **IE** in the CAN Control Register). The Interrupt Register will be updated even when **IE** is reset.

The application software has two possibilities to follow the source of a message interrupt. First, it can follow the **IntId** in the Interrupt Register and second it can poll the Interrupt Pending Register.

An interrupt service routine that is reading the message that is the source of the interrupt may read the message and reset the Message Object's **IntPnd** at the same time (bit **ClrIntPnd** in the Command Mask Register). When **IntPnd** is cleared, the Interrupt Register will point to the next Message Object with a pending interrupt.

5.13.6.10 Configuring the Bit Timing

Even if minor errors in the configuration of the CAN bit timing do not result in immediate failure, the performance of a CAN network can be reduced significantly.

In many cases, the CAN bit synchronization will amend a faulty configuration of the CAN bit timing to such a degree that only occasionally an error frame is generated. However, in the case of arbitration, when two or more CAN nodes simultaneously try to transmit a frame, a misplaced sample point may cause one of the transmitters to become error passive.

The analysis of such sporadic errors requires a detailed knowledge of the CAN bit synchronization inside a CAN node and interaction of the CAN nodes on the CAN bus.

5.13.6.10.1 Bit Time and Bit Rate

CAN supports bit rates in the range of lower than 1 kBit/s up to 1000 kBit/s. Each member of the CAN network has its own clock generator, usually a quartz oscillator. The timing parameter of the bit time (i.e. the reciprocal of the bit rate) can be configured individually for each CAN node, creating a common bit rate even though the oscillator periods of the CAN nodes (**fosc**) may be

different.

The frequencies of these oscillators are not absolutely stable, small variations are caused by changes in temperature or voltage and by deteriorating components. As long as the variations remain inside a specific oscillator tolerance range (df), the CAN nodes are able to compensate for the different bit rates by re-synchronizing to the bit stream.

According to the CAN specification, the bit time is divided into four segments (see Figure 5-82). The Synchronization Segment, the Propagation Time Segment, the Phase Buffer Segment 1 and the Phase Buffer Segment 2. Each segment consists of a specific, programmable number of time quanta (see Table 5-16). The length of the time quantum (tq), which is the basic time unit of the bit time, is defined by the CAN controller's APB clock f_{APB} and the BRP bit of the Bit Timing Register (CAN_BTR): $tq = BRP / f_{APB}$.

The Synchronization Segment, Sync_Seg, is that part of the bit time where edges of the CAN bus level are expected to occur. The distance between an edge that occurs outside of Sync_Seg, and the Sync_Seg is called the phase error of that edge. The Propagation Time Segment, Prop_Seg, is intended to compensate for the physical delay times within the CAN network. The Phase Buffer Segments Phase_Seg1 and Phase_Seg2 surround the Sample Point. The (Re-)Synchronization Jump Width (SJW) defines how far a re-synchronization may move the Sample Point inside the limits defined by the Phase Buffer Segments to compensate for edge phase errors.

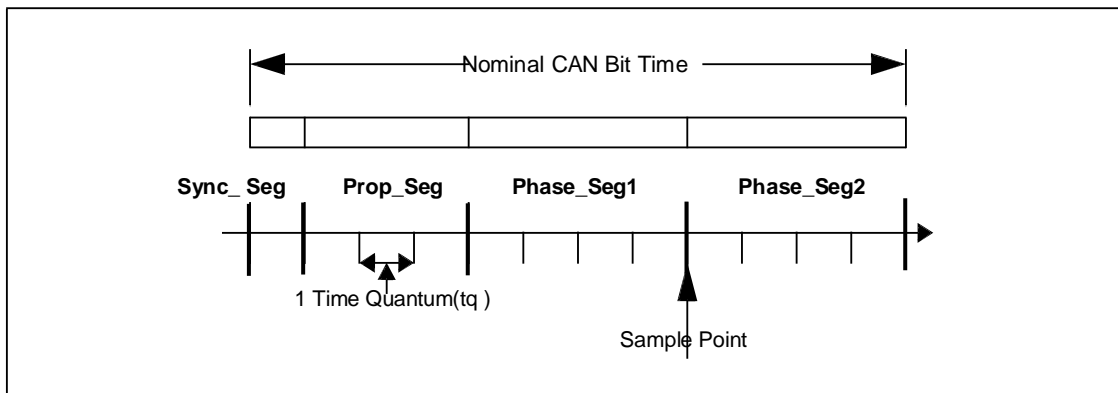

Figure 5-82 Bit Timing



Parameter	Range	Remark
BRP	[1 .. 32]	defines the length of the time quantum tq
Sync_Seg	1 tq	fixed length, synchronization of bus input to APB clock
Prop_Seg	[1.. 8] tq	compensates for the physical delay times
Phase_Seg1	[1..8] tq	may be lengthened temporarily by synchronization
Phase_Seg2	[1.. 8] tq	may be shortened temporarily by synchronization
SJW	[1 .. 4] tq	may not be longer than either Phase Buffer Segment
This table describes the minimum programmable ranges required by the CAN protocol		

Table 5-16 CAN Bit Time Parameters

A given bit rate may be met by different bit time configurations, but for the proper function of the CAN network the physical delay times and the oscillator's tolerance range have to be considered.

5.13.6.10.2 Propagation Time Segment

This part of the bit time is used to compensate physical delay times within the network. These delay times consist of the signal propagation time on the bus and the internal delay time of the CAN nodes.

Any CAN node synchronized to the bit stream on the CAN bus will be out of phase with the transmitter of that bit stream, caused by the signal propagation time between the two nodes. The CAN protocol's non-destructive bitwise arbitration and the dominant acknowledge bit provided by receivers of CAN messages requires that a CAN node transmitting a bit stream must also be able to receive dominant bits transmitted by other CAN nodes that are synchronized to that bit stream. The example in Figure 5-83 shows the phase shift and propagation times between two CAN nodes.

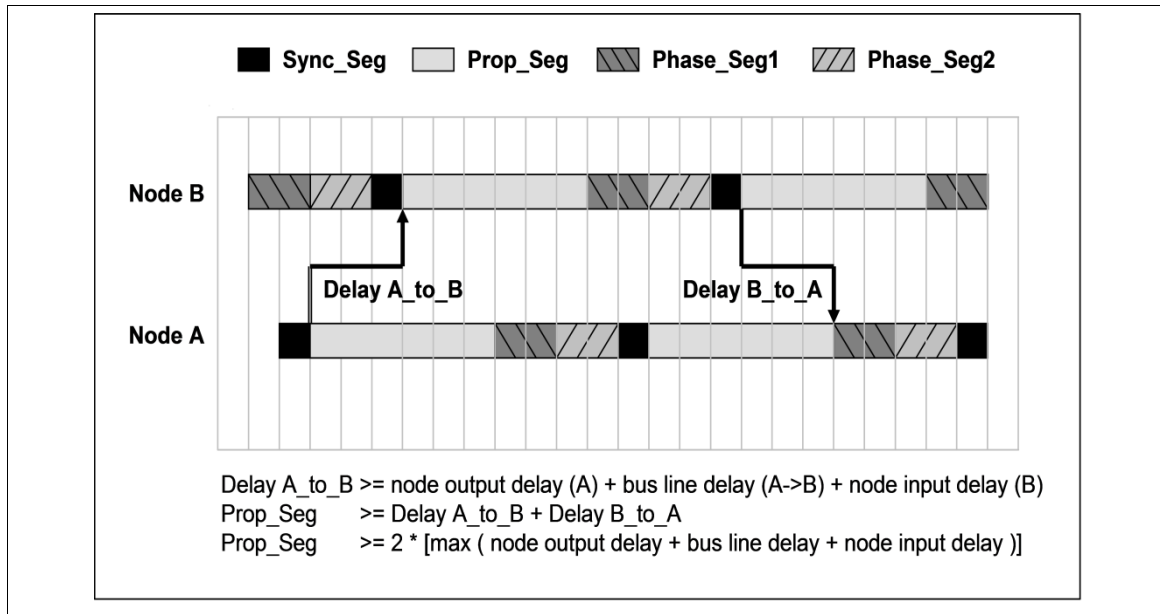

Figure 5-83 Propagation Time Segment

In this example, both nodes A and B are transmitters, performing an arbitration for the CAN bus. Node A has sent its Start of Frame bit less than one bit time earlier than node B, therefore node B has synchronized itself to the received edge from recessive to dominant. Since node B has received this edge delay (A_to_B) after it has been transmitted, B's bit timing segments are shifted with respect to A. Node B sends an identifier with higher priority and so it will win the arbitration at a specific identifier bit when it transmits a dominant bit while node A transmits a recessive bit. The dominant bit transmitted by node B will arrive at node A after the delay (B_to_A).

Due to oscillator tolerances, the actual position of node A's Sample Point can be anywhere inside the nominal range of node A's Phase Buffer Segments, so the bit transmitted by node B must arrive at node A before the start of Phase_Seg1. This condition defines the length of Prop_Seg.

If the edge from recessive to dominant transmitted by node B arrives at node A after the start of Phase_Seg1, it can happen that node A samples a recessive bit instead of a dominant bit, resulting in a bit error and the destruction of the current frame by an error flag.

The error occurs only when two nodes arbitrate for the CAN bus that have oscillators of opposite ends of the tolerance range and that are separated by a long bus line. This is an example of a minor error in the bit timing configuration (Prop_Seg too short) that causes sporadic bus errors.

Some CAN implementations provide an optional 3 Sample Mode but the C_CAN does not. In this mode, the CAN bus input signal passes a digital low-pass filter, using three samples and a majority logic to determine the valid bit value. This results in an additional input delay of 1 tq, requiring a longer Prop_Seg.

5.13.6.10.3 Phase Buffer Segments and Synchronization

The Phase Buffer Segments (Phase_Seg1 and Phase_Seg2) and the Synchronization Jump Width (SJW) are used to compensate for the oscillator tolerance. The Phase Buffer Segments may be lengthened or shortened by synchronization.



Synchronizations occur on edges from recessive to dominant, their purpose is to control the distance between edges and Sample Points.

Edges are detected by sampling the actual bus level in each time quantum and comparing it with the bus level at the previous Sample Point. A synchronization may be done only if a recessive bit was sampled at the previous Sample Point and if the bus level at the actual time quantum is dominant.

An edge is synchronous if it occurs inside of Sync_Seg, otherwise the distance between edge and the end of Sync_Seg is the edge phase error, measured in time quanta. If the edge occurs before Sync_Seg, the phase error is negative, else it is positive.

Two types of synchronization exist, Hard Synchronization and Re-synchronization.

A Hard Synchronization is done once at the start of a frame and inside a frame only when Re-synchronizations occur.

- **Hard Synchronization**

After a hard synchronization, the bit time is restarted with the end of Sync_Seg, regardless of the edge phase error. Thus hard synchronization forces the edge, which has caused the hard synchronization to lie within the synchronization segment of the restarted bit time.

- **Bit Re-synchronization**

Re-synchronization leads to a shortening or lengthening of the bit time such that the position of the sample point is shifted with regard to the edge.

When the phase error of the edge which causes Re-synchronization is positive, Phase_Seg1 is lengthened. If the magnitude of the phase error is less than SJW, Phase_Seg1 is lengthened by the magnitude of the phase error, else it is lengthened by SJW.

When the phase error of the edge, which causes Re-synchronization is negative, Phase_Seg2 is shortened. If the magnitude of the phase error is less than SJW, Phase_Seg2 is shortened by the magnitude of the phase error, else it is shortened by SJW.

When the magnitude of the phase error of the edge is less than or equal to the programmed value of SJW, the results of Hard Synchronization and Re-synchronization are the same. If the magnitude of the phase error is larger than SJW, the Re-synchronization cannot compensate the phase error completely, an error (phase error - SJW) remains.

Only one synchronization may be done between two Sample Points. The Synchronizations maintain a minimum distance between edges and Sample Points, giving the bus level time to stabilize and filtering out spikes that are shorter than (Prop_Seg + Phase_Seg1).

Apart from noise spikes, most synchronizations are caused by arbitration. All nodes synchronize “hard” on the edge transmitted by the “leading” transceiver that started transmitting first, but due to propagation delay times, they cannot become ideally synchronized. The “leading” transmitter does not necessarily win the arbitration, therefore the receivers have to synchronize themselves to different transmitters that subsequently “take the lead” and that are differently synchronized to the previously “leading” transmitter. The same happens at the acknowledge field, where the transmitter and some of the receivers will have to synchronize to that receiver that “takes the lead” in the transmission of the dominant acknowledge bit.

Synchronizations after the end of the arbitration will be caused by oscillator tolerance, when the differences in the oscillator’s clock periods of transmitter and receivers sum up during the time between synchronizations (at most ten bits). These summarized differences may not be longer than the SJW, limiting the oscillator’s tolerance range.

The examples in Figure 5-84 show how the Phase Buffer Segments are used to compensate for phase errors. There are three drawings of each two consecutive bit timings. The upper drawing shows the synchronization on a “late” edge, the lower drawing shows the synchronization on an “early” edge, and the middle drawing is the reference without synchronization.

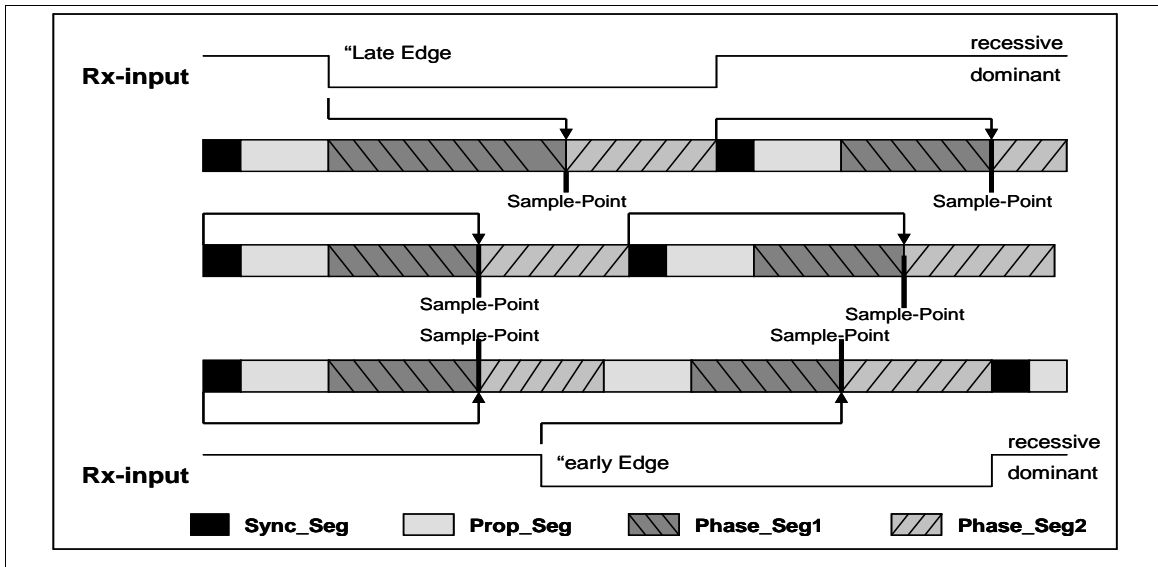

Figure 5-84 Synchronization on “late” and “early” Edges

In the first example an edge from recessive to dominant occurs at the end of Prop_Seg. The edge is “late” since it occurs after the Sync_Seg. Reacting to the “late” edge, Phase_Seg1 is lengthened so that the distance from the edge to the Sample Point is the same as it would have been from the Sync_Seg to the Sample Point if no edge had occurred. The phase error of this “late” edge is less than SJW, so it is fully compensated and the edge from dominant to recessive at the end of the bit, which is one nominal bit time long, occurs in the Sync_Seg.

In the second example an edge from recessive to dominant occurs during Phase_Seg2. The edge is “early” since it occurs before a Sync_Seg. Reacting to the “early” edge, Phase_Seg2 is shortened and Sync_Seg is omitted, so that the distance from the edge to the Sample Point is the same as it would have been from an Sync_Seg to the Sample Point if no edge had occurred. As in the previous example, the magnitude of this “early” edge’s phase error is less than SJW, so it is fully compensated.

The Phase Buffer Segments are lengthened or shortened temporarily only; at the next bit time, the segments return to their nominal programmed values.

In these examples, the bit timing is seen from the point of view of the CAN implementation’s state machine, where the bit time starts and ends at the Sample Points. The state machine omits Sync_Seg when synchronising on an “early” edge because it cannot subsequently redefine that time quantum of Phase_Seg2 where the edge occurs to be the Sync_Seg.

The examples in Figure 5-85 show how short dominant noise spikes are filtered by synchronisations. In both examples the spike starts at the end of Prop_Seg and has the length of (Prop_Seg + Phase_Seg1).

In the first example, the Synchronisation Jump Width is greater than or equal to the phase error of the spike’s edge from recessive to dominant. Therefore the Sample Point is shifted after the end of the spike; a recessive bus level is sampled.

In the second example, SJW is shorter than the phase error, so the Sample Point cannot be shifted far enough; the dominant spike is sampled as actual bus level.

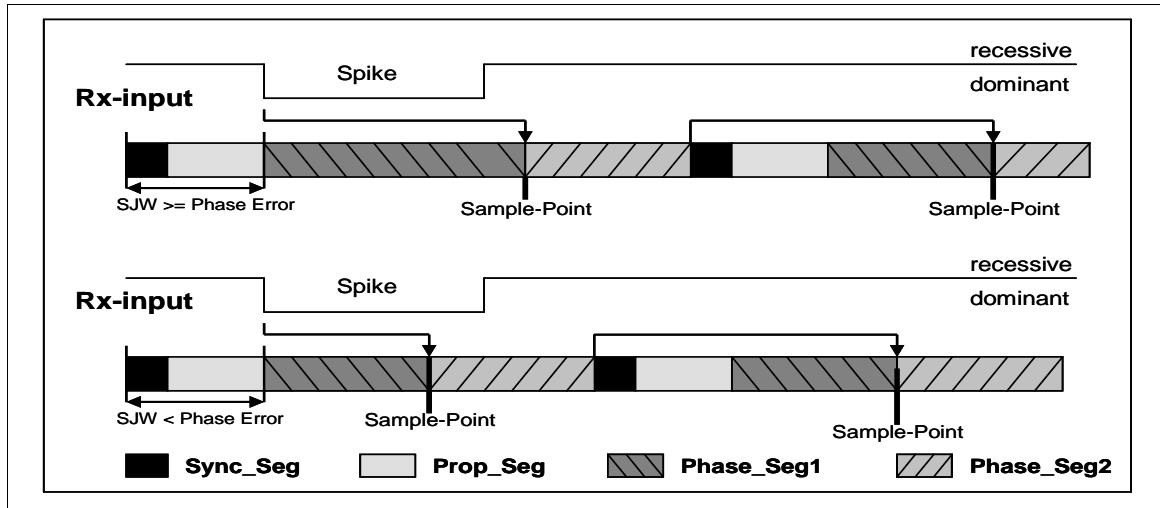

Figure 5-85 Filtering of Short Dominant Spikes

5.13.6.10.4 Oscillator Tolerance Range

The oscillator tolerance range was increased when the CAN protocol was developed from version 1.1 to version 1.2 (version 1.0 was never implemented in silicon). The option to synchronize on edges from dominant to recessive became obsolete, only edges from recessive to dominant are considered for synchronization. The protocol update to version 2.0 (A and B) had no influence on the oscillator tolerance.

The tolerance range df for an oscillator frequency f_{osc} around the nominal frequency f_{nom} is:

$$(1 - df) \cdot f_{nom} \leq f_{osc} \leq (1 + df) \cdot f_{nom}$$

It depends on the proportions of Phase_Seg1, Phase_Seg2, SJW, and the bit time. The maximum tolerance df is defined by two conditions (both shall be met):

錯誤! 物件無法用編輯功能變數代碼來建立。

錯誤! 物件無法用編輯功能變數代碼來建立。

Note: These conditions base on the APB cock = f_{osc} .

It has to be considered that SJW may not be larger than the smaller of the Phase Buffer Segments and that the Propagation Time Segment limits that part of the bit time that may be used for the Phase Buffer Segments.

The combination Prop_Seg = 1 and Phase_Seg1 = Phase_Seg2 = SJW = 4 allows the largest possible oscillator tolerance of 1.58%. This combination with a Propagation Time Segment of only 10% of the bit time is not suitable for short bit times; it can be used for bit rates of up to 125



kBit/s (bit time = 8 μ s) with a bus length of 40 m.

5.13.6.10.5 Configuring the CAN Protocol Controller

In most CAN implementations and also in the C_CAN, the bit timing configuration is programmed in two register bytes. The sum of Prop_Seg and Phase_Seg1 (as TSEG1) is combined with Phase_Seg2 (as TSEG2) in one byte, SJW and BRP are combined in the other byte.

In these bit timing registers, the four components TSEG1, TSEG2, SJW, and BRP have to be programmed to a numerical value that is one less than its functional value. Therefore, instead of values in the range of [1..n], values in the range of [0..n-1] are programmed. That way, e.g. SJW (functional range of [1..4]) is represented by only two bits.

Therefore the length of the bit time is (programmed values) [TSEG1 + TSEG2 + 3] t_q or (functional values) [Sync_Seg + Prop_Seg + Phase_Seg1 + Phase_Seg2] t_q .

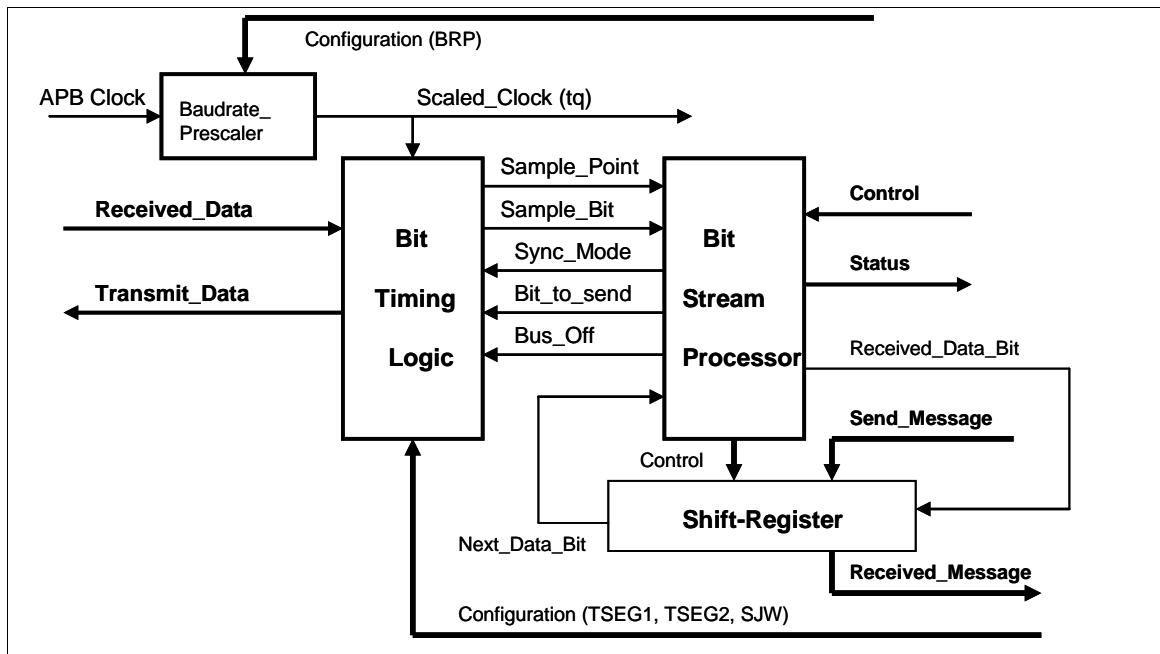

Figure 5-86 Structure of the CAN Core's CAN Protocol Controller

The data in the bit timing registers is the configuration input of the CAN protocol controller. The Baud Rate Prescaler (configured by BRP) defines the length of the time quantum, the basic time unit of the bit time; the Bit Timing Logic (configured by TSEG1, TSEG2, and SJW) defines the number of time quanta in the bit time.

The processing of the bit time, the calculation of the position of the Sample Point, and occasional synchronizations are controlled by the BTL (Bit Timing Logic) state machine, which is evaluated once each time quantum. The rest of the CAN protocol controller, the BSP (Bit Stream Processor) state machine is evaluated once each bit time, at the Sample Point.

The Shift Register sends the messages serially and parallelizes received messages. Its loading and shifting is controlled by the BSP.

The BSP translates messages into frames and vice versa. It generates and discards the enclosing fixed format bits, inserts and extracts stuff bits, calculates and checks the CRC code, performs the error management, and decides which type of synchronization is to be used. It is evaluated at the Sample Point and processes the sampled bus input bit. The time that is needed to calculate the next bit to be sent after the Sample point (e.g. data bit, CRC bit, stuff bit, error flag, or idle) is called the Information Processing Time (IPT).

The IPT is application specific but may not be longer than $2 t_q$; the IPT for the C_CAN is $0 t_q$. Its length is the lower limit of the programmed length of Phase_Seg2. In case of a synchronization, Phase_Seg2 may be shortened to a value less than IPT, which does not affect bus timing.

5.13.6.10.6 Calculating Bit Timing Parameters

Usually, the calculation of the bit timing configuration starts with a desired bit rate or bit time. The resulting bit time (1/bit rate) must be an integer multiple of the APB clock period.

The bit time may consist of 4 to 25 time quanta, the length of the time quantum t_q is defined by the Baud Rate Prescaler with $t_q = (\text{Baud Rate Prescaler})/f_{\text{apb_clk}}$. Several combinations may lead to the desired bit time, allowing iterations of the following steps.

First part of the bit time to be defined is the Prop_Seg. Its length depends on the delay times measured in the APB clock. A maximum bus length as well as a maximum node delay has to be defined for expandible CAN bus systems. The resulting time for Prop_Seg is converted into time quanta (rounded up to the nearest integer multiple of t_q).

The Sync_Seg is 1 t_q long (fixed), leaving $(\text{bit time} - \text{Prop_Seg} - 1) t_q$ for the two Phase Buffer Segments. If the number of remaining t_q is even, the Phase Buffer Segments have the same length, $\text{Phase_Seg2} = \text{Phase_Seg1}$, else $\text{Phase_Seg2} = \text{Phase_Seg1} + 1$.

The minimum nominal length of Phase_Seg2 has to be regarded as well. Phase_Seg2 may not be shorter than the IPT of the CAN controller, which, depending on the actual implementation, is in the range of $[0..2] t_q$.

The length of the Synchronization Jump Width is set to its maximum value, which is the minimum of 4 and Phase_Seg1.

The oscillator tolerance range necessary for the resulting configuration is calculated by the formulas given in Section 5.13.6.10.4: Oscillator Tolerance Range

If more than one configuration is possible, that configuration allowing the highest oscillator tolerance range should be chosen.

CAN nodes with different system clocks require different configurations to come to the same bit rate. The calculation of the propagation time in the CAN network, based on the nodes with the longest delay times, is done once for the whole network.

The oscillator tolerance range of the CAN systems is limited by that node with the lowest tolerance range.

The calculation may show that bus length or bit rate have to be decreased or that the stability of the oscillator frequency has to be increased in order to find a protocol compliant configuration of the CAN bit timing. The resulting configuration is written into the Bit Timing Register: $(\text{Phase_Seg2}-1) \& (\text{Phase_Seg1}+\text{Prop_Seg}-1) \& (\text{SynchronisationJumpWidth}-1)\&(\text{Prescaler}-1)$



Example for Bit Timing at High Baud rate

In this example, the frequency of APB_CLK is 10 MHz, BRP is 0, the bit rate is 1 MBit/s.

T_q	100	ns	= t_{APB_CLK}
delay of bus driver	50	ns	
delay of receiver circuit	30	ns	
delay of bus line (40m)	220	ns	
t_{Prop}	600	ns	= $6 \cdot t_q$
t_{SJW}	100	ns	= $1 \cdot t_q$
t_{TSeg1}	700	ns	= $t_{Prop} + t_{SJW}$
t_{TSeg2}	200	ns	= Information Processing Time + $1 \cdot t_q$
$t_{Sync-Seg}$	100	ns	= $1 \cdot t_q$
bit time	1000	ns	= $t_{Sync-Seg} + t_{TSeg1} + t_{TSeg2}$
tolerance for APB_CLK	0.39	%	= $\frac{Min(PB1, PB2)}{2 \times 13 \times (bit\ time - PB2)}$

錯誤! 物件無法用編輯功能變數代碼來建立。

In this example, the concatenated bit time parameters are $(2-1)_3 \& (7-1)_4 \& (1-1)_2 \& (1-1)_6$, the Bit Timing Register is programmed to = 0x1600.



Example for Bit Timing at Low Baudrate

In this example, the frequency of APB_CLK is 2 MHz, BRP is 1, the bit rate is 100 KBit/s.

t_q	1	$\mu s = 2 \cdot t_{APB_CLK}$
delay of bus driver	200	ns
delay of receiver circuit	80	ns
delay of bus line (40m)	220	ns
t_{Prop}	1	$\mu s = 1 \cdot t_q$
t_{SJW}	4	$\mu s = 4 \cdot t_q$
t_{TSeg1}	5	$\mu s = t_{Prop} + t_{SJW}$
t_{TSeg2}	4	$\mu s = \text{Information Processing Time} + 3 \cdot t_q$
$t_{Sync-Seg}$	1	$\mu s = 1 \cdot t_q$
bit time	10	$\mu s = t_{Sync-Seg} + t_{TSeg1} + t_{TSeg2}$
tolerance for APB_CLK	1.58	$\% = \frac{Min(PB1, PB2)}{2 \times 13 \times (bit\ time - PB2)}$

錯誤! 物件無法用編輯功能變數代碼來建立。

In this example, the concatenated bit time parameters are $(4-1)_3 \& (5-1)_4 \& (4-1)_2 \& (2-1)_6$, the Bit Timing Register is programmed to= 0x34C1.



5.13.7 Register Description

The C_CAN allocates an address space of 256 bytes. The registers are organized as 16-bit registers.

The two sets of interface registers (IF1 and IF2) control the software access to the Message RAM. They buffer the data to be transferred to and from the RAM, avoiding conflicts between software accesses and message reception/transmission.

5.13.8 Register Map

R: read only, W: write only, R/W: both read and write

Register	Offset	R/W	Description	Reset Value
CAN Base Address:				
CAN0_BA = 0x4018_0000				
CAN_CON	CAN0_BA+0x00	R/W	CAN Control Register	0x0000_0001
CAN_STATUS	CAN0_BA+0x04	R/W	CAN Status Register	0x0000_0000
CAN_ERR	CAN0_BA+0x08	R	Error Counter Register	0x0000_0000
CAN_BTIME	CAN0_BA+0x0C	R/W	Bit Timing Register	0x0000_2301
CAN_IIDR	CAN0_BA+0x10	R	Interrupt Identifier Register	0x0000_0000
CAN_TEST	CAN0_BA+0x14	R/W	Test Register	0x0000_00x0
CAN_BRPE	CAN0_BA+0x18	R/W	Baud Rate Prescaler Extension Register	0x0000_0000
CAN_IF1_CREQ	CAN0_BA+0x20	R/W	IF1 ⁽²⁾ Command Request Registers	0x0000_0001
CAN_IF2_CREQ	CAN0_BA+0x80	R/W	IF2 ⁽²⁾ Command Request Registers	0x0000_0001
CAN_IF1_CMASK	CAN0_BA+0x24	R/W	IF1 Command Mask Registers	0x0000_0000
CAN_IF2_CMASK	CAN0_BA+0x84	R/W	IF2 Command Mask Registers	0x0000_0000
CAN_IF1_MASK1	CAN0_BA+0x28	R/W	IF1 Mask 1 Register	0x0000_FFFF
CAN_IF2_MASK1	CAN0_BA+0x88	R/W	IF2 Mask 1 Register	0x0000_FFFF
CAN_IF1_MASK2	CAN0_BA+0x2C	R/W	IF1 Mask 2 Register	0x0000_FFFF
CAN_IF2_MASK2	CAN0_BA+0x8C	R/W	IF2 Mask 2 Register	0x0000_FFFF
CAN_IF1_ARB1	CAN0_BA+0x30	R/W	IF1 Arbitration 1 Register	0x0000_0000
CAN_IF2_ARB1	CAN0_BA+0x90	R/W	IF2 Arbitration 1 Register	0x0000_0000
CAN_IF1_ARB2	CAN0_BA+0x34	R/W	IF1 Arbitration 2 Register	0x0000_0000
CAN_IF2_ARB2	CAN0_BA+0x94	R/W	IF2 Arbitration 2 Register	0x0000_0000
CAN_IF1_MCON	CAN0_BA+0x38	R/W	IF1 Message Control Registers	0x0000_0000
CAN_IF2_MCON	CAN0_BA+0x98	R/W	IF2 Message Control Registers	0x0000_0000
CAN_IF1_DAT_A1	CAN0_BA+0x3C	R/W	IF1 Data A1 ⁽³⁾ Registers	0x0000_0000
CAN_IF1_DAT_A2	CAN0_BA+0x40	R/W	IF1 Data A2 ⁽³⁾ Registers	0x0000_0000



CAN_IF1_DAT_B1	CAN0_BA+0x44	R/W	IF1 Data B1 ⁽³⁾ Registers	0x0000_0000
CAN_IF1_DAT_B2	CAN0_BA+0x48	R/W	IF1 Data B2 ⁽³⁾ Registers	0x0000_0000
CAN_IF2_DAT_A1	CAN0_BA+0x9C	R/W	IF2 Data A1 ⁽³⁾ Registers	0x0000_0000
CAN_IF2_DAT_A2	CAN0_BA+0xA0	R/W	IF2 Data A2 ⁽³⁾ Registers	0x0000_0000
CAN_IF2_DAT_B1	CAN0_BA+0xA4	R/W	IF2 Data B1 ⁽³⁾ Registers	0x0000_0000
CAN_IF2_DAT_B2	CAN0_BA+0xA8	R/W	IF2 Data B2 ⁽³⁾ Registers	0x0000_0000
CAN_TXREQ1	CAN0_BA+0x100	R	Transmission Request Register 1	0x0000_0000
CAN_TXREQ2	CAN0_BA+0x104	R	Transmission Request Register 2	0x0000_0000
CAN_NDAT1	CAN0_BA+0x120	R	New Data Register 1	0x0000_0000
CAN_NDAT2	CAN0_BA+0x124	R	New Data Register 2	0x0000_0000
CAN_IPND1	CAN0_BA+0x140	R	Interrupt Pending Register 1	0x0000_0000
CAN_IPND2	CAN0_BA+0x144	R	Interrupt Pending Register 2	0x0000_0000
CAN_MVLD1	CAN0_BA+0x160	R	Message Valid Register 1	0x0000_0000
CAN_MVLD2	CAN0_BA+0x164	R	Message Valid Register 2	0x0000_0000
CAN_WU_EN	CAN0_BA+0x168	R/W	Wake Up Function Enable	0x0000_0000
CAN_WU_STATUS	CAN0_BA+0x16C	R/W	Wake Up Function Status	0x0000_0000

Note: 1. 0x00 & 0br0000000, where r signifies the actual value of the CAN_RX

2. IFn: The two sets of Message Interface Registers – IF1 and IF2, have identical function
3. An/Bn: The two sets of data registers – A1, A2 and B1, B2.

5.13.9 CAN Interface Reset State

After the hardware reset, the C_CAN registers hold the reset values given in the register Description in [CAN register map](#) .

Additionally the *busoff* state is reset and the output CAN_TX is set to recessive (HIGH). The value 0x0001 (Init = '1') in the CAN Control Register enables the software initialization. The C_CAN does not influence the CAN bus until the application software resets the Init bit to '0'.

The data stored in the Message RAM is not affected by a hardware reset. After powering on, the contents of the Message RAM are undefined.



CAN Register Map for Each Bit Function

Addr offset	Register Name	1 5	1 4	1 3	1 2	1 1	1 0	9	8	7	6	5	4	3	2	1	0	
00h	CAN_CON	Reserved									Test	CCE	DAR	Res	EIE	SIE	IE	Init
04h	CAN_STATUS	Reserved									BOff	EWarn	EPass	RxOk	TxOk	LEC		
08h	CAN_ERR	RP	REC6-0						TEC7-0									
0Ch	CAN_BTIME	Reserved	TSeg2			TSeg1			SJW			BRP						
10h	CAN_IIDR	IntId15-8									IntId7-0							
14h	CAN_TEST	Reserved									Rx	Tx1	Tx0	LBack	Silent	Basic	Reserved	
18h	CAN_BRPE	Reserved											BRPE					
20h	CAN_IF1_CREQ	Busy	Reserved									Message Number						
24h	CAN_IF1_CMASK	Reserved									WR/RD	Mask	Arb	Control	CirIntPnd	TxRqst/	Data A	Data B
28h	CAN_IF1_MASK1	Msk15-0																
2Ch	CAN_IF1_MASK2	Mxtd	MDir	Reserved	Msk28-16													
30h	CAN_IF1_ARB1	ID15-0																
34h	CAN_IF1_ARB2	MsgVal	Xtd	Dir	ID28-16													



Addr Offset	Register Name	1 5	1 4	1 3	1 2	1 1	1 0	9	8	7	6	5	4	3	2	1	0
38h	CAN_IF1_MCON	NewDat	MsgLst	IntPnd	UMask	TxIE	RxIE	RmtEn	TxRqst	EOB	Reserved			DLC3-0			
3Ch	CAN_IF1_DAT_A1	Data(1)								Data(0)							
40h	CAN_IF1_DAT_A2	Data(3)								Data(2)							
44h	CAN_IF1_DAT_B1	Data(5)								Data(4)							
48h	CAN_IF1_DAT_B2	Data(7)								Data(6)							
80h	CAN_IF2_CREQ	Busy	Reserved								Message Number						
84h	CAN_IF2_CMASK	Reserved								WR/RD	Mask	Arb	Control	CirIntPnd	TxRqst/	Data A	Data B
88h	CAN_IF2_MASK1	Msk15-0															
8Ch	CAN_IF2_MASK2	MXtd	MDir	Reser ved	Msk28-16												
90h	CAN_IF2_ARB1	ID15-0															
94h	CAN_IF2_ARB2	MsgVal	Xtd	Dir	ID28-16												
98h	CAN_IF2_MCON	NewDat	MsgLst	IntPnd	UMask	TxIE	RxIE	RmtEn	TxRqst	EOB	Reserved			DLC3-0			
9Ch	CAN_IF2_DAT_A1	Data(1)								Data(0)							



Addr offset	Register Name	1 5	1 4	1 3	1 2	1 1	1 0	9	8	7	6	5	4	3	2	1	0	
A0h	CAN_IF2_DAT_A2	Data(3)							Data(2)									
A4h	CAN_IF2_DAT_B1	Data(5)							Data(4)									
A8h	CAN_IF2_DAT_B2	Data(7)							Data(6)									
100h	CAN_TXREQ1	TxRqst16-1																
104h	CAN_TXREQ2	TxRqst32-17																
120h	CAN_NDAT1	NewDat16-1																
124h	CAN_NDAT2	NewDat32-17																
140h	CAN_IPND1	IntPnd16-1																
144h	CAN_IPND2	IntPnd32-17																
160h	CAN_MVLD1	MsgVal16-1																
164h	CAN_MVLD2	MsgVal32-17																
168h	CAN_WU_EN	Reserved															WAKU P_EN	
16Ch	CAN_WU_STATUS	Reserved															WAKU P_STS	
170h	CAN_RAM_CEN	Reserved															RAM_C EN	
Others	Reserved	Reserved																

Table 5-17 CAN Register Map for Each Bit Function

Note: Reserved bits are read as 0' except for IFn Mask 2 Register where they are read as '1'.



CAN Control Register (CAN_CON)

Register	Offset	R/W	Description	Reset Value
CAN_CON	CAN0_BA+0x00	R/W	CAN Control Register	0x0000_0001

31	30	29	28	27	26	25	24
Reserved							
23	22	21	20	19	18	17	16
Reserved							
15	14	13	12	11	10	9	8
Reserved							
7	6	5	4	3	2	1	0
Test	CCE	DAR	Reserved	EIE	SIE	IE	Init

Bits	Description	
[31:8]	Reserved	<p>Reserved</p> <p>There are reserved bits.</p> <p>These bits are always read as '0' and must always be written with '0'</p>
[7]	Test	<p>Test Mode Enable</p> <p>1 = Test Mode.</p> <p>0 = Normal Operation.</p>
[6]	CCE	<p>Configuration Change Enable</p> <p>1 = Write access to the Bit Timing Register (CAN_BTIME & CAN_BRP) allowed. (while Init bit =1).</p> <p>0 = No write access to the Bit Timing Register.</p>
[5]	DAR	<p>Disable Automatic Re-transmission</p> <p>1 = Automatic Retransmission disabled.</p> <p>0 = Automatic Retransmission of disturbed messages enabled.</p>
[4]	Reserved	<p>Reserved</p> <p>This is a reserved bit. This bit is always read as '0' and must always be written with '0'.</p>
[3]	EIE	<p>Error Interrupt Enable</p> <p>1 = Enabled - A change in the bits BOff or EWarn in the Status Register will generate an interrupt.</p> <p>0 = Disabled - No Error Status Interrupt will be generated.</p>
[2]	SIE	<p>Status Change Interrupt Enable</p> <p>1 = Enabled - An interrupt will be generated when a message transfer is successfully completed or a CAN bus error is detected.</p> <p>0 = Disabled - No Status Change Interrupt will be generated.</p>
[1]	IE	<p>Module Interrupt Enable</p>



		1 = Enabled. 0 = Disabled.
[0]	Init	Init Initialization 1 = Initialization is started. 0 = Normal Operation.

Note: The busoff recovery sequence (see CAN Specification Rev. 2.0) cannot be shortened by setting or resetting the Init bit. If the device goes in the busoff state, it will set Init of its own accord, stopping all bus activities. Once Init has been cleared by the CPU, the device will then wait for 129 occurrences of Bus Idle (129 * 11 consecutive recessive bits) before resuming normal operations. At the end of the busoff recovery sequence, the Error Management Counters will be reset.

During the waiting time after resetting Init, each time a sequence of 11 recessive bits has been monitored, a Bit0Error code is written to the Status Register, enabling the CPU to readily check up whether the CAN bus is stuck at dominant or continuously disturbed and to monitor the proceeding of the busoff recovery sequence.



CAN Status Register (CAN_STATUS)

Register	Offset	R/W	Description	Reset Value
CAN_STATUS	CAN0_BA+0x04	R/W	CAN Status Register	0x0000_0000

31	30	29	28	27	26	25	24
Reserved							
23	22	21	20	19	18	17	16
Reserved							
15	14	13	12	11	10	9	8
Reserved							
7	6	5	4	3	2	1	0
BOFF	EWarn	EPass	RxOK	TxOK	LEC		

Bits	Description
[31:8]	<p>Reserved</p> <p>Reserved This is a reserved bit. This bit is always read as '0' and must always be written with '0'.</p>
[7]	<p>BOff</p> <p>Busoff Status (Read Only) 1 = The CAN module is in busoff state. 0 = The CAN module is not in busoff state.</p>
[6]	<p>EWarn</p> <p>Error Warning Status (Read Only) 1 = At least one of the error counters in the EML has reached the error warning limit of 96. 0 = Both error counters are below the error warning limit of 96.</p>
[5]	<p>EPass</p> <p>Error Passive (Read Only) 1 = The CAN Core is in the error passive state as defined in the CAN Specification. 0 = The CAN Core is error active.</p>
[4]	<p>RxOK</p> <p>Received a Message Successfully 1 = A message has been successfully received since this bit was last reset by the CPU (independent of the result of acceptance filtering). 0 = No message has been successfully received since this bit was last reset by the CPU. This bit is never reset by the CAN Core.</p>
[3]	<p>TxOK</p> <p>Transmitted a Message Successfully 1 = Since this bit was last reset by the CPU, a message has been successfully (error free and acknowledged by at least one other node) transmitted. 0 = Since this bit was reset by the CPU, no message has been successfully transmitted. This bit is never reset by the CAN Core.</p>
[2:0]	<p>LEC</p> <p>Last Error Code (Type of the last error to occur on the CAN bus) The LEC field holds a code, which indicates the type of the last error to occur on the CAN bus. This field will be cleared to '0' when a message has been transferred (reception or transmission) without error. The unused code '7' may be written by the CPU to check for updates. Table 5-18 describes the error codes.</p>



Error Code	Meanings
0	No Error
1	Stuff Error: More than 5 equal bits in a sequence have occurred in a part of a received message where this is not allowed.
2	Form Error: A fixed format part of a received frame has the wrong format.
3	AckError: The message this CAN Core transmitted was not acknowledged by another node.
4	Bit1Error: During the transmission of a message (with the exception of the arbitration field), the device wanted to send a recessive level (bit of logical value '1'), but the monitored bus value was dominant.
5	Bit0Error: During the transmission of a message (or acknowledge bit, or active error flag, or overload flag), though the device wanted to send a dominant level (data or identifier bit logical value '0'), but the monitored Bus value was recessive. During busoff recovery, this status is set each time a sequence of 11 recessive bits has been monitored. This enables the CPU to monitor the proceedings of the busoff recovery sequence (indicating the bus is not stuck at <i>dominant</i> or continuously disturbed).
6	CRCErrror: The CRC check sum was incorrect in the message received, the CRC received for an incoming message does not match with the calculated CRC for the received data.
7	Unused: When the LEC shows the value '7', no CAN bus event was detected since the CPU wrote this value to the LEC.

Table 5-18 Error Codes

Status Interrupts

A Status Interrupt is generated by bits **BOff** and **EWarn** (Error Interrupt) or by **RxOk**, **TxOk**, and **LEC** (Status Change Interrupt) assumed that the corresponding enable bits in the CAN Control Register are set. A change of bit **EPass** or a write to **RxOk**, **TxOk**, or **LEC** will never generate a Status Interrupt.

Reading the Status Register will clear the Status Interrupt value (8000h) in the Interrupt Register, if it is pending.



CAN Error Counter Register (CAN_ERR)

Register	Offset	R/W	Description	Reset Value
CAN_ERR	CAN0_BA+0x08	R	Error Counter Register	0x0000_0000

31	30	29	28	27	26	25	24
Reserved							
23	22	21	20	19	18	17	16
Reserved							
15	14	13	12	11	10	9	8
RP	REC[6:0]						
7	6	5	4	3	2	1	0
TEC[7:0]							

Bits	Description	
[31:16]	Reserved	Reserved This is a reserved bit. This bit is always read as '0' and must always be written with '0'.
[15]	RP	Receive Error Passive 1 = The Receive Error Counter has reached the error passive level as defined in the CAN Specification. 0 = The Receive Error Counter is below the error passive level.
[14:8]	REC	Receive Error Counter Actual state of the Receive Error Counter. Values between 0 and 127.
[7:0]	TEC	Transmit Error Counter Actual state of the Transmit Error Counter. Values between 0 and 255.



Bit Timing Register (CAN_BTIME)

Register	Offset	R/W	Description	Reset Value
CAN_BTIME	CAN0_BA+0x0C	R/W	Bit Timing Register	0x0000_2301

31	30	29	28	27	26	25	24
Reserved							
23	22	21	20	19	18	17	16
Reserved							
15	14	13	12	11	10	9	8
Reserved	TSeg2			TSeg1			
7	6	5	4	3	2	1	0
SJW		BRP					

Bits	Description	
[31:15]	Reserved	Reserved This is a reserved bit. This bit is always read as '0' and must always be written with '0'.
[14:12]	TSeg2	Time Segment After sample Point 0x0-0x7: Valid values for TSeg2 are [0 ... 7]. The actual interpretation by the hardware of this value is such that one more than the value programmed here is used.
[11:8]	TSeg1	Time Segment before the sample Point Minus Sync_seg 0x01-0x0F: valid values for TSeg1 are [1 ... 15]. The actual interpretation by the hardware of this value is such that one more than the value programmed is used.
[7:6]	SJW	(Re)Synchronization Jump Width 0x0-0x3: Valid programmed values are [0 ... 3]. The actual interpretation by the hardware of this value is such that one more than the value programmed here is used.
[5:0]	BRP	Baud Rate Prescaler 0x01-0x3F: The value by which the oscillator frequency is divided for generating the bit time quanta. The bit time is built up from a multiple of this quanta. Valid values for the Baud Rate Prescaler are [0 ... 63]. The actual interpretation by the hardware of this value is such that one more than the value programmed here is used.

Note With a module clock APB_CLK of 8 MHz, the reset value of 0x2301 configures the C_CAN for a bit rate of 500 kBit/s. The registers are only writable if bits CCE and Init in the CAN Control Register are set.



Interrupt Identify Register (CAN_IIDR)

Register	Offset	R/W	Description	Reset Value
CAN_IIDR	CAN0_BA+0x10	R	Interrupt Identifier Register	0x0000_0000

31	30	29	28	27	26	25	24
Reserved							
23	22	21	20	19	18	17	16
Reserved							
15	14	13	12	11	10	9	8
IntId[15:8]							
7	6	5	4	3	2	1	0
IntId[7:0]							

Bits	Description
[15:0]	<p>IntId</p> <p>Interrupt Identifier (Indicates the source of the interrupt. Ref. Table 5-19)</p> <p>If several interrupts are pending, the CAN Interrupt Register will point to the pending interrupt with the highest priority, disregarding their chronological order. An interrupt remains pending until the application software has cleared it. If IntId is different from 0x0000 and IE is set, the IRQ interrupt signal to the EIC is active. The interrupt remains active until IntId is back to value 0x0000 (the cause of the interrupt is reset) or until IE is reset.</p> <p>The Status Interrupt has the highest priority. Among the message interrupts, the Message Object' s interrupt priority decreases with increasing message number.</p> <p>A message interrupt is cleared by clearing the Message Object's IntPnd bit. The Status Interrupt is cleared by reading the Status Register.</p>

IntId Value	Meanings
0x0000	No Interrupt is Pending
0x0001-0x0020	Number of Message Object which caused the interrupt.
0x0021-0x7FFF	Unused
0x8000	Status Interrupt
0x8001-0xFFFF	Unused

Table 5-19 Source of Interrupts



Test Register (CAN_TEST)

Register	Offset	R/W	Description	Reset Value
CAN_TEST	CAN0_BA+0x14	R/W	Test Register	0x0000_00x0

31	30	29	28	27	26	25	24
Reserved							
23	22	21	20	19	18	17	16
Reserved							
15	14	13	12	11	10	9	8
Reserved							
7	6	5	4	3	2	1	0
Rx	Tx[1:0]		LBack	Silent	Basic	Res	

Bits	Description	
[31:8]	Reserved	Reserved There are reserved bits. These bits are always read as '0' and must always be written with '0'.
[7]	Rx	Monitors the actual value of CAN_RX Pin (Read Only) 1 = The CAN bus is recessive (CAN_RX = '1'). 0 = The CAN bus is dominant (CAN_RX = '0').
[6:5]	Tx	Tx[1:0]: Control of CAN_TX Pin 00 = Reset value, CAN_TX is controlled by the CAN Core 01 = Sample Point can be monitored at CAN_TX pin 10 = CAN_TX pin drives a dominant ('0') value. 11 = CAN_TX pin drives a recessive ('1') value.
[4]	LBack	Loop Back Mode 1 = Loop Back Mode Enabled. 0 = Loop Back Mode Disabled.
[3]	Silent	Silent Mode 1 = The module is in Silent Mode. 0 = Normal operation.
[2]	Basic	Basic Mode 1 = IF1 Registers used as Tx Buffer, IF2 Registers used as Rx Buffer. 0 = Basic Mode disabled.
[1:0]	Res	Reserved There are reserved bits. These bits are always read as '0' and must always be written with '0'.



Reset value: 0000 0000 R000 0000 b (R:current value of RX pin)

Write access to the Test Register is enabled by setting the Test bit in the CAN Control Register. The different test functions may be combined, but **Tx[1-0]** ≠ "00" disturbs message transfer.



Baud Rate Prescaler Extension REGISTER (CAN BRPE)

Register	Offset	R/W	Description	Reset Value
CAN_BRPE	CAN0_BA+0x18	R/W	Baud Rate Prescaler Extension Register	0x0000_0000

31	30	29	28	27	26	25	24
Reserved							
23	22	21	20	19	18	17	16
Reserved							
15	14	13	12	11	10	9	8
Reserved							
7	6	5	4	3	2	1	0
Reserved				BRPE			

Bits	Description	
[31:4]	Reserved	<p>Reserved</p> <p>There are reserved bits. These bits are always read as '0' and must always be written with '0'.</p>
[3:0]	BRPE	<p>BRPE: Baud Rate Prescaler Extension</p> <p>0x00-0x0F: By programming BRPE, the Baud Rate Prescaler can be extended to values up to 1023. The actual interpretation by the hardware is that one more than the value programmed by BRPE (MSBs) and BTIME (LSBs) is used.</p>



Message Interface Register Sets

There are two sets of Interface Registers, which are used to control the CPU access to the Message RAM. The Interface Registers avoid conflict between the CPU accesses to the Message RAM and CAN message reception and transmission by buffering the data to be transferred. A complete Message Object or parts of the Message Object may be transferred between the Message RAM and the IF n Message Buffer registers in one single transfer.

The function of the two interface register sets is identical except for the Basic test mode. They can be used the way one set of registers is used for data transfer to the Message RAM while the other set of registers is used for the data transfer from the Message RAM, allowing both processes to be interrupted by each other. Table 5-20 (IF1 and IF2 Message Interface Register Set) provides an overview of the two Interface Register sets.

Each set of Interface Registers consists of Message Buffer Registers controlled by their own Command Registers. The Command Mask Register specifies the direction of the data transfer and which parts of a Message Object will be transferred. The Command Request Register is used to select a Message Object in the Message RAM as target or source for the transfer and to start the action specified in the Command Mask Register.

Address	IF1 Register Set	Address	IF2 Register Set
CAN0_BA+0x20	IF1 Command Request	CAN0_BA+0x80	IF2 Command Request
CAN0_BA+0x24	IF1 Command Mask	CAN0_BA+0x84	IF2 Command Mask
CAN0_BA+0x28	IF1 Mask 1	CAN0_BA+0x88	IF2 Mask 1
CAN0_BA+0x2C	IF1 Mask 2	CAN0_BA+0x8C	IF2 Mask 2
CAN0_BA+0x30	IF1 Arbitration 1	CAN0_BA+0x90	IF2 Arbitration 1
CAN0_BA+0x34	IF1 Arbitration 2	CAN0_BA+0x94	IF2 Arbitration 2
CAN0_BA+0x38	IF1 Message Control	CAN0_BA+0x98	IF2 Message Control
CAN0_BA+0x3C	IF1 Data A 1	CAN0_BA+0x9C	IF2 Data A 1
CAN0_BA+0x40	IF1 Data A 2	CAN0_BA+0xA0	IF2 Data A 2
CAN0_BA+0x44	IF1 Data B 1	CAN0_BA+0xA4	IF2 Data B 1
CAN0_BA+0x48	IF1 Data B 2	CAN0_BA+0xA8	IF2 Data B 2

Table 5-20 IF1 and IF2 Message Interface Register



IFn Command Request Register (CAN IFn CREQ)

Register	Offset	R/W	Description	Reset Value
CAN_IF1_CREQ	CAN0_BA+0x20	R/W	IF1 ⁽²⁾ Command Request Registers	0x0000_0001
CAN_IF2_CREQ	CAN0_BA+0x80	R/W	IF2 ⁽²⁾ Command Request Registers	0x0000_0001

31	30	29	28	27	26	25	24
Reserved							
23	22	21	20	19	18	17	16
Reserved							
15	14	13	12	11	10	9	8
Busy	Res						
7	6	5	4	3	2	1	0
Res		Message Number					

Bits	Description
[15]	<p>Busy</p> <p>Busy Flag 1 = Writing to the IFn Command Request Register is in progress. This bit can only be read by the software. 0 = Read/write action has finished.</p>
[14:6]	<p>Reserved</p> <p>There are reserved bits. These bits are always read as '0' and must always be written with '0'.</p>
[5:0]	<p>Message Number</p> <p>0x01-0x20: Valid Message Number, the Message Object in the Message RAM is selected for data transfer. 0x00: Not a valid Message Number, interpreted as 0x20. 0x21-0x3F: Not a valid Message Number, interpreted as 0x01-0x1F.</p>

A message transfer is started as soon as the application software has written the message number to the Command Request Register. With this write operation, the Busy bit is automatically set to notify the CPU that a transfer is in progress. After a waiting time of 3 to 6 APB_CLK periods, the transfer between the Interface Register and the Message RAM is completed. The Busy bit is cleared.

Note:When a Message Number that is not valid is written into the Command Request Register, the Message Number will be transformed into a valid value and that Message Object will be transferred.



IFn Command Mask Register (CAN_IFn_CMASK)

The control bits of the IFn Command Mask Register specify the transfer direction and select which of the IFn Message Buffer Registers are source or target of the data transfer.

Register	Offset	R/W	Description	Reset Value
CAN_IF1_CMASK	CAN0_BA+0x24	R/W	IF1 Command Mask Registers	0x0000_0000
CAN_IF2_CMASK	CAN0_BA+0x84	R/W	IF2 Command Mask Registers	0x0000_0000

31	30	29	28	27	26	25	24
Reserved							
23	22	21	20	19	18	17	16
Reserved							
15	14	13	12	11	10	9	8
Reserved							
7	6	5	4	3	2	1	0
WR/RD	Mask	Arb	Control	ClrIntPnd	TxRqst/ NewDat	DAT_A	DAT_B

Bits	Description
[31:8]	<p>Reserved</p> <p>There are reserved bits. These bits are always read as '0' and must always be written with '0'.</p>
[7]	<p>Write / Read</p> <p>1 = Write: Transfer data from the selected Message Buffer Registers to the Message Object addressed by the Command Request Register.</p> <p>0 = Read: Transfer data from the Message Object addressed by the Command Request Register into the selected Message Buffer Registers.</p>
[6]	<p>Access Mask Bits</p> <p><u>Direction = Write</u></p> <p>1 = Transfer Identifier Mask + MDir + MXtd to Message Object.</p> <p>0 = Mask bits unchanged.</p> <p><u>Direction = Read</u></p> <p>1 = Transfer Identifier Mask + MDir + MXtd to IFn Message Buffer Register.</p> <p>0 = Mask bits unchanged.</p>
[5]	<p>Access Arbitration Bits</p> <p><u>Direction = Write</u></p> <p>1 = Transfer Identifier + Dir + Xtd + MsgVal to Message Object</p> <p>0 = Arbitration bits unchanged.</p> <p><u>Direction = Read</u></p> <p>1 = Transfer Identifier + Dir + Xtd + MsgVal to IFn Message Buffer Register.</p> <p>0 = Arbitration bits unchanged.</p>



[4]	Control	<p>Control Access Control Bits</p> <p><u>Direction = Write</u></p> <p>1 = Transfer Control Bits to Message Object. 0 = Control Bits unchanged</p> <p><u>Direction = Read</u></p> <p>1 = Transfer Control Bits to IFn Message Buffer Register. 0 = Control Bits unchanged.</p>
[3]	ClrIntPnd	<p>Clear Interrupt Pending Bit</p> <p><u>Direction = Write</u></p> <p>When writing to a Message Object, this bit is ignored.</p> <p><u>Direction = Read</u></p> <p>1 = Clear IntPnd bit in the Message Object. 0 = IntPnd bit remains unchanged.</p>
[2]	TxRqst/NewDat	<p>Access Transmission Request Bit when <u>Direction = Write</u></p> <p>1 = Set TxRqst bit. 0 = TxRqst bit unchanged.</p> <p>Note: If a transmission is requested by programming bit TxRqst/NewDat in the IFn Command Mask Register, bit TxRqst in the IFn Message Control Register will be ignored.</p> <p>Access New Data Bit when <u>Direction = Read</u></p> <p>1 = Clear NewDat bit in the Message Object 0 = NewDat bit remains unchanged.</p> <p>Note: A read access to a Message Object can be combined with the reset of the control bits IntPnd and NewDat. The values of these bits transferred to the IFn Message Control Register always reflect the status before resetting these bits.</p>
[1]	DAT_A	<p>Access Data Bytes [3:0]</p> <p><u>Direction = Write</u></p> <p>1 = Transfer Data Bytes [3:0] to Message Object 0 = Data Bytes [3:0] unchanged.</p> <p><u>Direction = Read</u></p> <p>1 = Transfer Data Bytes [3:0] to IFn Message Buffer Register. 0 = Data Bytes [3:0] unchanged.</p>
[0]	DAT_B	<p>Access Data Bytes [7:4]</p> <p><u>Direction = Write</u></p> <p>1 = Transfer Data Bytes [7:4] to Message Object. 0 = Data Bytes [7:4] unchanged.</p> <p><u>Direction = Read</u></p> <p>1 = Transfer Data Bytes [7:4] to IFn Message Buffer Register. 0 = Data Bytes [7:4] unchanged.</p>



IFn Mask 1 Register (CAN IFn MASK1)

Register	Offset	R/W	Description	Reset Value
CAN_IF1_MASK1	CAN0_BA+0x28	R/W	IF1 Mask 1 Register	0x0000_FFFF
CAN_IF2_MASK1	CAN0_BA+0x88	R/W	IF2 Mask 1 Register	0x0000_FFFF

31	30	29	28	27	26	25	24
Reserved							
23	22	21	20	19	18	17	16
Reserved							
15	14	13	12	11	10	9	8
Msk[15:8]							
7	6	5	4	3	2	1	0
Msk[7:0]							

Bits	Description	
[31:16]	Reserved	Reserved There are reserved bits. These bits are always read as '0' and must always be written with '0'.
[15:0]	Msk[15:0]	Identifier Mask 15-0 1 = The corresponding identifier bit is used for acceptance filtering. 0 = The corresponding bit in the identifier of the message object cannot inhibit the match in the acceptance filtering.



IFn Mask 2 Register (CAN IFn MASK2)

Register	Offset	R/W	Description	Reset Value
CAN_IF1_MASK2	CAN0_BA+0x2C	R/W	IF1 Mask 2 Register	0x0000_FFFF
CAN_IF2_MASK2	CAN0_BA+0x8C	R/W	IF2 Mask 2 Register	0x0000_FFFF

31	30	29	28	27	26	25	24	
Reserved								
23	22	21	20	19	18	17	16	
Reserved								
15	14	13	12	11	10	9	8	
MXtd	MDir	Reserved	Msk[28:24]					
7	6	5	4	3	2	1	0	
Msk[23:16]								

Bits	Description	
[31:16]	Reserved	Reserved There are reserved bits. These bits are always read as '0' and must always be written with '0'.
[15]	MXtd	Mask Extended Identifier 1 = The extended identifier bit (IDE) is used for acceptance filtering. 0 = The extended identifier bit (IDE) has no effect on the acceptance filtering. Note: When 11-bit ("standard") Identifiers are used for a Message Object, the identifiers of received Data Frames are written into bits ID28 to ID18 . For acceptance filtering, only these bits together with mask bits Msk28 to Msk18 are considered.
[14]	MDir	Mask Message Direction 1 = The message direction bit (Dir) is used for acceptance filtering. 0 = The message direction bit (Dir) has no effect on the acceptance filtering.
[13]	Reserved	Reserved This is reserved bit. The bit is always read as '1' and must always be written with '1'.
[12:0]	Msk[28:16]	Identifier Mask 28-16 1 = The corresponding identifier bit is used for acceptance filtering. 0 = The corresponding bit in the identifier of the message object cannot inhibit the match in the acceptance filtering.



IFn Arbitration 1 Register (CAN IFn_ARB1)

Register	Offset	R/W	Description	Reset Value
CAN_IF1_ARB1	CAN0_BA+0x30	R/W	IF1 Arbitration 1 Register	0x0000_0000
CAN_IF2_ARB1	CAN0_BA+0x90	R/W	IF2 Arbitration 1 Register	0x0000_0000

31	30	29	28	27	26	25	24
Reserved							
23	22	21	20	19	18	17	16
Reserved							
15	14	13	12	11	10	9	8
ID[15:8]							
7	6	5	4	3	2	1	0
ID[7:0]							

Bits	Description	
[31:16]	Reserved	Reserved There are reserved bits. These bits are always read as '0' and must always be written with '0'.
[15:0]	ID[15:0]	Message Identifier 15-0 ID28 - ID0, 29-bit Identifier ("Extended Frame"). ID28 - ID18, 11-bit Identifier ("Standard Frame")



IFn Arbitration 2 Register (CAN IFn_ARB2)

Register	Offset	R/W	Description	Reset Value
CAN_IF1_ARB2	CAN0_BA+0x34	R/W	IF1 Arbitration 2 Register	0x0000_0000
CAN_IF2_ARB2	CAN0_BA+0x94	R/W	IF2 Arbitration 2 Register	0x0000_0000

31	30	29	28	27	26	25	24	
Reserved								
23	22	21	20	19	18	17	16	
Reserved								
15	14	13	12	11	10	9	8	
MsgVal	Xtd	Dir	ID[28:24]					
7	6	5	4	3	2	1	0	
ID[23:16]								

Bits	Description	
[31:16]	Reserved	Reserved There are reserved bits. These bits are always read as '0' and must always be written with '0'.
[15]	MsgVal	Message Valid 1 = The Message Object is configured and should be considered by the Message Handler. 0 = The Message Object is ignored by the Message Handler. Note: The application software must reset the MsgVal bit of all unused Messages Objects during the initialization before it resets bit Init in the CAN Control Register. This bit must also be reset before the identifier Id28-0 , the control bits Xtd , Dir , or the Data Length Code DLC3-0 are modified, or if the Messages Object is no longer required.
[14]	Xtd	Extended Identifier 1 = The 29-bit ("extended") Identifier will be used for this Message Object. 0 = The 11-bit ("standard") Identifier will be used for this Message Object.
[13]	Dir	Message Direction 1 = Direction is transmit On TxRqst , the respective Message Object is transmitted as a Data Frame. On reception of a Remote Frame with matching identifier, the TxRqst bit of this Message Object is set (if RmtEn = one). 0 = Direction is receive On TxRqst , a Remote Frame with the identifier of this Message Object is transmitted. On reception of a Data Frame with matching identifier, that message is stored in this Message Object.
[12:0]	ID[28:16]	Message Identifier 28-16 ID28 - ID0, 29-bit Identifier ("Extended Frame"). ID28 - ID18, 11-bit Identifier ("Standard Frame")



IFn Message Control Register (CAN IFn MCON)

Register	Offset	R/W	Description	Reset Value
CAN_IF1_MCON	CAN0_BA+0x38	R/W	IF1 Message Control Registers	0x0000_0000
CAN_IF2_MCON	CAN0_BA+0x98	R/W	IF2 Message Control Registers	0x0000_0000

31	30	29	28	27	26	25	24
Reserved							
23	22	21	20	19	18	17	16
Reserved							
15	14	13	12	11	10	9	8
NewDat	MsgLst	IntPnd	UMask	TxIE	RxIE	RmtEn	TxRqst
7	6	5	4	3	2	1	0
EoB	Reserved			DLC[3:0]			

Bits	Description
[31:16]	<p>Reserved</p> <p>Reserved</p> <p>There are reserved bits. These bits are always read as '0' and must always be written with '0'.</p>
[15]	<p>NewDat</p> <p>New Data</p> <p>1 = The Message Handler or the application software has written new data into the data portion of this Message Object.</p> <p>0 = No new data has been written into the data portion of this Message Object by the Message Handler since last time this flag was cleared by the application software.</p>
[14]	<p>MsgLst</p> <p>Message Lost (only valid for Message Objects with direction = receive)</p> <p>1 = The Message Handler stored a new message into this object when NewDat was still set, the CPU has lost a message.</p> <p>0 = No message lost since last time this bit was reset by the CPU.</p>
[13]	<p>IntPnd</p> <p>Interrupt Pending</p> <p>1 = This message object is the source of an interrupt. The Interrupt Identifier in the Interrupt Register will point to this message object if there is no other interrupt source with higher priority.</p> <p>0 = This message object is not the source of an interrupt.</p>
[12]	<p>UMask</p> <p>Use Acceptance Mask</p> <p>1 = Use Mask (Msk28-0, MXtd, and MDir) for acceptance filtering.</p> <p>0 = Mask ignored.</p> <p>Note: If the UMask bit is set to one, the Message Object's mask bits have to be programmed during initialization of the Message Object before MsgVal is set to one.</p>
[11]	<p>TxIE</p> <p>Transmit Interrupt Enable</p> <p>1 = IntPnd will be set after a successful transmission of a frame.</p>



		0 = IntPnd will be left unchanged after the successful transmission of a frame.
[10]	RxlE	<p>Receive Interrupt Enable</p> <p>1 = IntPnd will be set after a successful reception of a frame.</p> <p>0 = IntPnd will be left unchanged after a successful reception of a frame.</p>
[9]	RmtEn	<p>Remote Enable</p> <p>1 = At the reception of a Remote Frame, TxRqst is set.</p> <p>0 = At the reception of a Remote Frame, TxRqst is left unchanged.</p>
[8]	TxRqst	<p>Transmit Request</p> <p>1 = The transmission of this Message Object is requested and is not yet done.</p> <p>0 = This Message Object is not waiting for transmission.</p>
[7]	EoB	<p>End of Buffer</p> <p>1 = Single Message Object or last Message Object of a FIFO Buffer.</p> <p>0 = Message Object belongs to a FIFO Buffer and is not the last Message Object of that FIFO Buffer.</p> <p>Note: This bit is used to concatenate two or more Message Objects (up to 32) to build a FIFO Buffer. For single Message Objects (not belonging to a FIFO Buffer), this bit must always be set to one.</p>
[6:4]	Reserved	<p>Reserved</p> <p>There are reserved bits. These bits are always read as '0' and must always be written with '0'.</p>
[3:0]	DLC	<p>Data Length Code</p> <p>0-8: Data Frame has 0-8 data bytes.</p> <p>9-15: Data Frame has 8 data bytes</p> <p>Note: The Data Length Code of a Message Object must be defined the same as in all the corresponding objects with the same identifier at other nodes. When the Message Handler stores a data frame, it will write the DLC to the value given by the received message.</p> <p>Data 0: 1st data byte of a CAN Data Frame</p> <p>Data 1: 2nd data byte of a CAN Data Frame</p> <p>Data 2: 3rd data byte of a CAN Data Frame</p> <p>Data 3: 4th data byte of a CAN Data Frame</p> <p>Data 4: 5th data byte of a CAN Data Frame</p> <p>Data 5: 6th data byte of a CAN Data Frame</p> <p>Data 6: 7th data byte of a CAN Data Frame</p> <p>Data 7 : 8th data byte of a CAN Data Frame</p> <p>Note: The Data 0 Byte is the first data byte shifted into the shift register of the CAN Core during a reception while the Data 7 byte is the last. When the Message Handler stores a Data Frame, it will write all the eight data bytes into a Message Object. If the Data Length Code is less than 8, the remaining bytes of the Message Object will be overwritten by unspecified values.</p>



IFn Data A1 Register (CAN IFn DAT A1)

Register	Offset	R/W	Description	Reset Value
CAN_IF1_DAT_A1	CAN0_BA+0x3C	R/W	IF1 Data A1 ^{(*)3} Registers	0x0000_0000
CAN_IF2_DAT_A1	CAN0_BA+0x9C	R/W	IF2 Data A1 ^{(*)3} Registers	0x0000_0000

31	30	29	28	27	26	25	24
Reserved							
23	22	21	20	19	18	17	16
Reserved							
15	14	13	12	11	10	9	8
Data(1)							
7	6	5	4	3	2	1	0
Data(0)							

Bits	Description	
[31:16]	Reserved	Reserved There are reserved bits. These bits are always read as '0' and must always be written with '0'.
[15:8]	Data1	Data byte 1 2nd data byte of a CAN Data Frame
[7:0]	Data0	Data byte 0 1st data byte of a CAN Data Frame



IFn Data A2 Register (CAN IFn DAT A2)

Register	Offset	R/W	Description	Reset Value
CAN_IF1_DAT_A2	CAN0_BA+0x40	R/W	IF1 Data A2 ⁽³⁾ Registers	0x0000_0000
CAN_IF2_DAT_A2	CAN0_BA+0xA0	R/W	IF2 Data A2 ⁽³⁾ Registers	0x0000_0000

31	30	29	28	27	26	25	24
Reserved							
23	22	21	20	19	18	17	16
Reserved							
15	14	13	12	11	10	9	8
Data(3)							
7	6	5	4	3	2	1	0
Data(2)							

Bits	Description	
[31:16]	Reserved	Reserved There are reserved bits. These bits are always read as '0' and must always be written with '0'.
[15:8]	Data3	Data byte 3 4th data byte of CAN Data Frame
[7:0]	Data2	Data byte 2 3rd data byte of CAN Data Frame



IFn Data B1 Register (CAN IFn DAT B1)

Register	Offset	R/W	Description	Reset Value
CAN_IF1_DAT_B1	CAN0_BA+0x44	R/W	IF1 Data B1 ⁽³⁾ Registers	0x0000_0000
CAN_IF2_DAT_B1	CAN0_BA+0xA4	R/W	IF2 Data B1 ⁽³⁾ Registers	0x0000_0000

31	30	29	28	27	26	25	24
Reserved							
23	22	21	20	19	18	17	16
Reserved							
15	14	13	12	11	10	9	8
Data(5)							
7	6	5	4	3	2	1	0
Data(4)							

Bits	Description	
[31:16]	Reserved	Reserved There are reserved bits. These bits are always read as '0' and must always be written with '0'.
[15:8]	Data5	Data byte 5 6th data byte of CAN Data Frame
[7:0]	Data4	Data byte 4 5th data byte of CAN Data Frame



IFn Data B2 Register (CAN IFn DAT B2)

Register	Offset	R/W	Description	Reset Value
CAN_IF1_DAT_B2	CAN0_BA+0x48	R/W	IF1 Data B2 ⁽³⁾ Registers	0x0000_0000
CAN_IF2_DAT_B2	CAN0_BA+0xA8	R/W	IF2 Data B2 ⁽³⁾ Registers	0x0000_0000

31	30	29	28	27	26	25	24
Reserved							
23	22	21	20	19	18	17	16
Reserved							
15	14	13	12	11	10	9	8
Data(7)							
7	6	5	4	3	2	1	0
Data(6)							

Bits	Description	
[31:16]	Reserved	Reserved There are reserved bits. These bits are always read as '0' and must always be written with '0'.
[15:8]	Data7	Data byte 7 8th data byte of CAN Data Frame.
[7:0]	Data6	Data byte 6 7th data byte of CAN Data Frame.

In a CAN Data Frame, Data(0) is the first, Data(7) is the last byte to be transmitted or received. In CAN's serial bit stream, the MSB of each byte will be transmitted first.



Message Object in the Message Memory

There are 32 Message Objects in the Message RAM. To avoid conflicts between application software access to the Message RAM and CAN message reception and transmission, the CPU cannot directly access the Message Objects, these accesses are handled through the IF n Interface Registers. Table 5-21 provides an overview of the structures of a Message Object.

Message Object												
UMask	Msk [28:0]	MXtd	MDir	EoB	NewDat		MsgLst	RxIE	TxIE	IntPnd	RmtEn	TxRqst
MsgVal	ID [28:0]	Xtd	Dir	DLC [3:0]	Data0	Data1	Data2	Data3	Data4	Data5	Data6	Data7

Table 5-21 Structure of a Message Object in Message Memory

The Arbitration Registers **ID28-0**, **Xtd**, and **Dir** are used to define the identifier and type of outgoing messages and are used (together with the mask registers **Msk28-0**, **MXtd**, and **MDir**) for acceptance filtering of incoming messages. A received message is stored in the valid Message Object with matching identifier and Direction = *receive* (Data Frame) or Direction = *transmit* (Remote Frame). Extended frames can be stored only in Message Objects with **Xtd** = one, standard frames in Message Objects with **Xtd** = zero. If a received message (Data Frame or Remote Frame) matches with more than one valid Message Object, it is stored into that with the lowest message number.

Message Handler Registers

All Message Handler registers are read-only. Their contents (**TxRqst**, **NewDat**, **IntPnd**, and **MsgVal** bits of each Message Object and the Interrupt Identifier) are status information provided by the Message Handler FSM.



Transmission Request Register 1 (CAN_TXREQ1)

These registers hold the **TxRqst** bits of the 32 Message Objects. By reading the **TxRqst** bits, the software can check which Message Object in a Transmission Request is pending. The **TxRqst** bit of a specific Message Object can be set/reset by the application software through the IFn Message Interface Registers or by the Message Handler after reception of a Remote Frame or after a successful transmission.

Register	Offset	R/W	Description	Reset Value
CAN_TXREQ1	CAN0_BA+0x100	R	Transmission Request Register 1	0x0000_0000

31	30	29	28	27	26	25	24
Reserved							
23	22	21	20	19	18	17	16
Reserved							
15	14	13	12	11	10	9	8
TxRqst [16:9]							
7	6	5	4	3	2	1	0
TxRqst [8:1]							

Bits	Description	
[31:16]	Reserved	<p>Reserved</p> <p>There are reserved bits. These bits are always read as '0' and must always be written with '0'.</p>
[15:0]	TxRqst [16:1]	<p>Transmission Request Bits 16-1 (of all Message Objects)</p> <p>1 = The transmission of this Message Object is requested and is not yet done.</p> <p>0 = This Message Object is not waiting for transmission.</p> <p>These bits are read only.</p>



Transmission Request Register 2 (CAN_TXREQ2)

Register	Offset	R/W	Description	Reset Value
CAN_TXREQ2	CAN0_BA+0x104	R	Transmission Request Register 2	0x0000_0000

31	30	29	28	27	26	25	24
Reserved							
23	22	21	20	19	18	17	16
Reserved							
15	14	13	12	11	10	9	8
TxRqst[32:25]							
7	6	5	4	3	2	1	0
TxRqst[24:17]							

Bits	Description	
[31:16]	Reserved	Reserved There are reserved bits. These bits are always read as '0' and must always be written with '0'.
[15:0]	TxRqst [32:17]	Transmission Request Bits 32-17 (of all Message Objects) 1 = The transmission of this Message Object is requested and is not yet done. 0 = This Message Object is not waiting for transmission. These bits are read only.



New Data Register 1 (CAN_NDAT1)

These registers hold the **NewDat** bits of the 32 Message Objects. By reading out the **NewDat** bits, the software can check for which Message Object the data portion was updated. The **NewDat** bit of a specific Message Object can be set/reset by the software through the IFn Message Interface Registers or by the Message Handler after reception of a Data Frame or after a successful transmission.

Register	Offset	R/W	Description	Reset Value
CAN_NDAT1	CAN0_BA+0x120	R	New Data Register 1	0x0000_0000

31	30	29	28	27	26	25	24
Reserved							
23	22	21	20	19	18	17	16
Reserved							
15	14	13	12	11	10	9	8
NewData[16:9]							
7	6	5	4	3	2	1	0
NewData [8:1]							

Bits	Description	
[31:16]	Reserved	Reserved There are reserved bits. These bits are always read as '0' and must always be written with '0'.
[15:0]	NewData[16:1]	New Data Bits 16-1 (of all Message Objects) 1 = The Message Handler or the application software has written new data into the data portion of this Message Object. 0 = No new data has been written into the data portion of this Message Object by the Message Handler since the last time this flag was cleared by the application software.



New Data Register 2 (CAN_NDAT2)

Register	Offset	R/W	Description	Reset Value
CAN_NDAT2	CAN0_BA+0x124	R	New Data Register 2	0x0000_0000

31	30	29	28	27	26	25	24
Reserved							
23	22	21	20	19	18	17	16
Reserved							
15	14	13	12	11	10	9	8
NewData [32:25]							
7	6	5	4	3	2	1	0
NewData [24:17]							

Bits	Description	
[31:16]	Reserved	Reserved There are reserved bits. These bits are always read as '0' and must always be written with '0'.
[15:0]	NewData[32:17]	New Data Bits 32-17 (of all Message Objects) 1 = The Message Handler or the application software has written new data into the data portion of this Message Object. 0 = No new data has been written into the data portion of this Message Object by the Message Handler since the last time this flag was cleared by the application software.



Interrupt Pending Register 1 (CAN_IPND1)

These registers contain the **IntPnd** bits of the 32 Message Objects. By reading the **IntPnd** bits, the software can check for which Message Object an interrupt is pending. The **IntPnd** bit of a specific Message Object can be set/reset by the application software through the IFn Message Interface Registers or by the Message Handler after reception or after a successful transmission of a frame. This will also affect the value of **IntId** in the Interrupt Register.

Register	Offset	R/W	Description	Reset Value
CAN_IPND1	CAN0_BA+0x140	R	Interrupt Pending Register 1	0x0000_0000

31	30	29	28	27	26	25	24
Reserved							
23	22	21	20	19	18	17	16
Reserved							
15	14	13	12	11	10	9	8
IntPnd[16:9]							
7	6	5	4	3	2	1	0
IntPnd [8:1]							

Bits	Description	
[31:16]	Reserved	Reserved There are reserved bits. These bits are always read as '0' and must always be written with '0'.
[15:0]	IntPnd[16:1]	Interrupt Pending Bits 16-1 (of all Message Objects) 1 = This message object is the source of an interrupt. 0 = This message object is not the source of an interrupt.



Interrupt Pending Register 2 (CAN_IPND2)

Register	Offset	R/W	Description	Reset Value
CAN_IPND2	CAN0_BA+0x144	R	Interrupt Pending Register 2	0x0000_0000

31	30	29	28	27	26	25	24
Reserved							
23	22	21	20	19	18	17	16
Reserved							
15	14	13	12	11	10	9	8
IntPnd [32:25]							
7	6	5	4	3	2	1	0
IntPnd [24:17]							

Bits	Description	
[31:16]	Reserved	Reserved There are reserved bits. These bits are always read as '0' and must always be written with '0'.
[15:0]	IntPnd[32:17]	Interrupt Pending Bits 32-17(of all Message Objects) 1 = This message object is the source of an interrupt. 0 = This message object is not the source of an interrupt.



Message Valid Register 1 (CAN_MVLD1)

These registers hold the **MsgVal** bits of the 32 Message Objects. By reading the **MsgVal** bits, the application software can check which Message Object is valid. The **MsgVal** bit of a specific Message Object can be set/reset by the application software via the IFn Message Interface Registers.

Register	Offset	R/W	Description	Reset Value
CAN_MVLD1	CAN0_BA+0x160	R	Message Valid Register 1	0x0000_0000

31	30	29	28	27	26	25	24
Reserved							
23	22	21	20	19	18	17	16
Reserved							
15	14	13	12	11	10	9	8
MsgVal [16:9]							
7	6	5	4	3	2	1	0
MsgVal [8:1]							

Bits	Description	
[31:16]	Reserved	Reserved There are reserved bits. These bits are always read as '0' and must always be written with '0'.
[15:0]	MsgVal[16:1]	Message Valid Bits 16-1 (of all Message Objects) (Read Only) 1 = This Message Object is configured and should be considered by the Message Handler. 0 = This Message Object is ignored by the Message Handler. Ex. CAN_MVLD1[0] means Message object No.1 is valid or not. If CAN_MVLD1[0] is set, message object No.1 is configured.



Message Valid Register 2 (CAN_MVLD2)

Register	Offset	R/W	Description	Reset Value
CAN_MVLD2	CAN0_BA+0x164	R	Message Valid Register 2	0x0000_0000

31	30	29	28	27	26	25	24
Reserved							
23	22	21	20	19	18	17	16
Reserved							
15	14	13	12	11	10	9	8
MsgVal [32:25]							
7	6	5	4	3	2	1	0
MsgVal [24:17]							

Bits	Description
[31:16]	<p>Reserved</p> <p>Reserved</p> <p>There are reserved bits. These bits are always read as '0' and must always be written with '0'.</p>
[15:0]	<p>Message Valid Bits 32-17 (of all Message Objects) (Read only)</p> <p>1 = This Message Object is configured and should be considered by the Message Handler.</p> <p>0 = This Message Object is ignored by the Message Handler.</p> <p>Ex. CAN_MVLD2[15] means Message object No.32 is valid or not. If CAN_MVLD2[15] is set, message object No.32 is configured.</p>



Wake-up Enable Register (CAN_WU_EN)

Register	Offset	R/W	Description	Reset Value
CAN_WU_EN	CAN0_BA+0x168	R/W	Wake Up Function Enable	0x0000_0000

31	30	29	28	27	26	25	24
Reserved							
23	22	21	20	19	18	17	16
Reserved							
15	14	13	12	11	10	9	8
Reserved							
7	6	5	4	3	2	1	0
Reserved							WAKUP_EN

Bits	Description	
[31:1]	Reserved	<p>Reserved</p> <p>There are reserved bits. These bits are always read as '0' and must always be written with '0'.</p>
[0]	WAKUP_EN	<p>Wake Up Enable</p> <p>1 = The wake-up function is enable. 0 = The wake-up function is disable.</p> <p>Note: User can wake-up system when there is a falling edge in the CAN_Rx pin.</p>



Wake-up Status Register (CAN_WU_STATUS)

Register	Offset	R/W	Description	Reset Value
CAN_WU_STATUS	CAN0_BA+0x16C	R/W	Wake Up Function Status	0x0000_0000

31	30	29	28	27	26	25	24
Reserved							
23	22	21	20	19	18	17	16
Reserved							
15	14	13	12	11	10	9	8
Reserved							
7	6	5	4	3	2	1	0
Reserved							WAKUP_STS

Bits	Description	
[31:1]	Reserved	<p>Reserved</p> <p>There are reserved bits. These bits are always read as '0' and must always be written with '0'.</p>
[0]	WAKUP_STS	<p>Wake Up Status</p> <p>1 = Wake-up event is occurred.</p> <p>0 = No wake-up event is occurred.</p> <p>Note: The bit can be written '0' to clear.</p>



5.14 PS/2 Device Controller (PS2D)

5.14.1 Overview

PS/2 device controller provides basic timing control for PS/2 communication. All communication between the device and the host is managed through the CLK and DATA pins. Unlike PS/2 keyboard or mouse device controller, the received/transmit code needs to be translated as meaningful code by firmware. The device controller generates the CLK signal after receiving a request to send, but host has ultimate control over communication. DATA sent from the host to the device is read on the rising edge and DATA sent from device to the host is change after rising edge. A 16 bytes FIFO is used to reduce CPU intervention. S/W can select 1 to 16 bytes for a continuous transmission.

5.14.2 Features

- Host communication inhibit and request to send detection
- Reception frame error detection
- Programmable 1 to 16 bytes transmit buffer to reduce CPU intervention
- Double buffer for data reception
- S/W override bus



5.14.3 Block Diagram

The PS/2 device controller consists of APB interface and timing control logic for DATA and CLK lines.

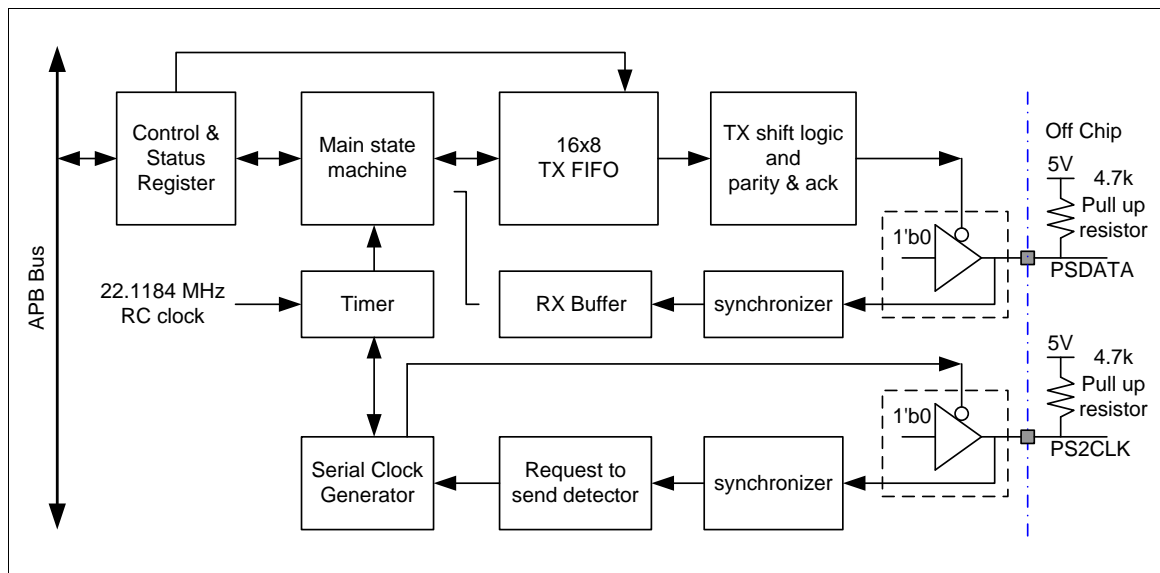

Figure 5-87 PS/2 Device Block Diagram



5.14.4 Functional Description

5.14.4.1 Communication

The PS/2 device implements a bidirectional synchronous serial protocol. The bus is "Idle" when both lines are high (open-collector). This is the only state where the device is allowed start to transmit DATA. The host has ultimate control over the bus and may inhibit communication at any time by pulling the CLK line low.

The CLK signal is generated by PS/2 device. If the host wants to send DATA, it must first inhibit communication from the device by pulling CLK low. The host then pulls DATA low and releases CLK. This is the "Request-to-Send" state and signals the device to start generating CLK pulses.

DATA	CLK	Bus State
High	High	Idle
High	Low	Communication Inhibit
Low	High	Host Request to Send

All data is transmitted one byte at a time and each byte is sent in a frame consisting of 11 or 12 bits. These bits are:

- 1 start bit. This is always 0
- 8 DATA bits, least significant bit first
- 1 parity bit (odd parity)
- 1 stop bit. This is always 1
- 1 acknowledge bit (host-to-device communication only)

The parity bit is set if there is an even number of 1's in the data bits and cleared to 0 if there is an odd number of 1's in the data bits. The number of 1's in the data bits plus the parity bit always add up to an odd number set to 1. This is used for error detection. The device must check this bit and if incorrect it should respond as if it had received an invalid command.

The host may inhibit communication at any time by pulling the CLK line low for at least 100 microseconds. If a transmission is inhibited before the 11th clock pulse, the device must abort the current transmission and prepare to retransmit the current data when host releases Clock. In order to reserve enough time for s/w to decode host command, the transmit logic is blocked by RXINT bit, S/W must clear RXINT bit to start retransmit. S/W can write CLR_FIFO to 1 to reset FIFO pointer if need.

Device-to-Host

The device uses a serial protocol with 11-bit frames. These bits are:

- 1 start bit. This is always 0
- 8 DATA bits, least significant bit first
- 1 parity bit (odd parity)
- 1 stop bit. This is always 1

The device writes a bit on the DATA line when CLK is high, and it is read by the host when CLK is low. Figure 5-88 in the following illustrate this.

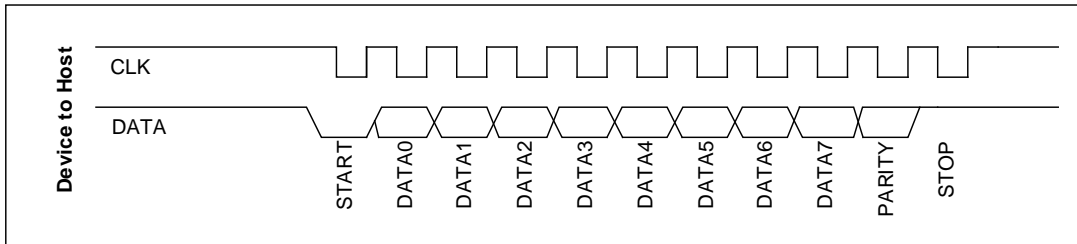

Figure 5-88 Data Format of Device-to-Host

Host-to-Device:

First of all, the PS/2 device always generates the CLK signal. If the host wants to send DATA, it must first put the CLK and DATA lines in a "Request-to-send" state as follows:

- Inhibit communication by pulling CLK low for at least 100 microseconds
- Apply "Request-to-send" by pulling DATA low, then release CLK

The device should check for this state at intervals not to exceed 10 milliseconds. When the device detects this state, it will begin generating CLK signals and CLK in eight DATA bits and one stop bit. The host changes the DATA line only when the CLK line is low, and DATA is read by the device when CLK is high.

After the stop bit is received, the device will acknowledge the received byte by bringing the DATA line low and generating one last CLK pulse. If the host does not release the DATA line after the 11th CLK pulse, the device will continue to generate CLK pulses until the DATA line is released.

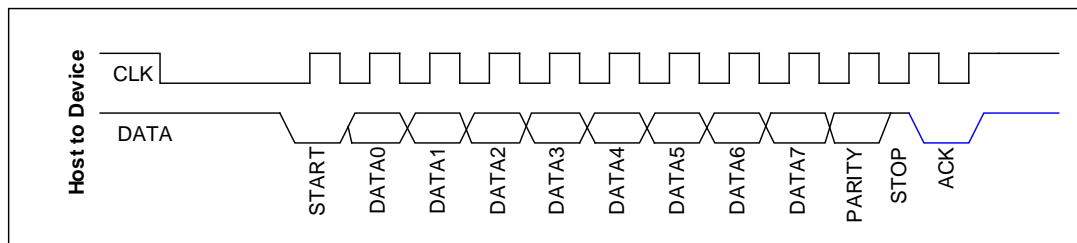

Figure 5-89 Data Format of Host-to-Device



The host and the device DATA and CLK detailed timing for communication is shown below.

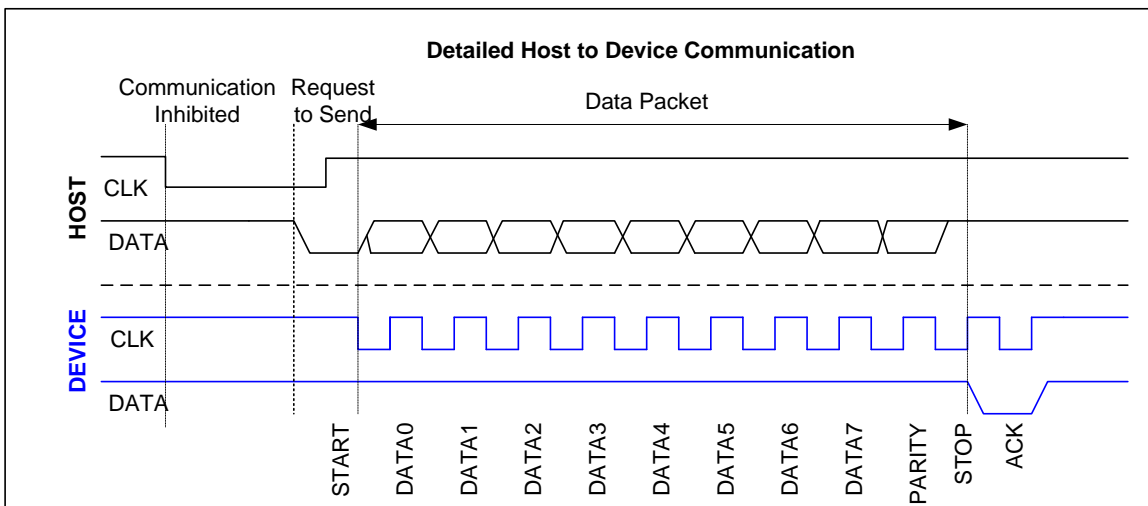

Figure 5-90 PS/2 Bit Data Format

5.14.4.2 PS/2 Bus Timing Specification

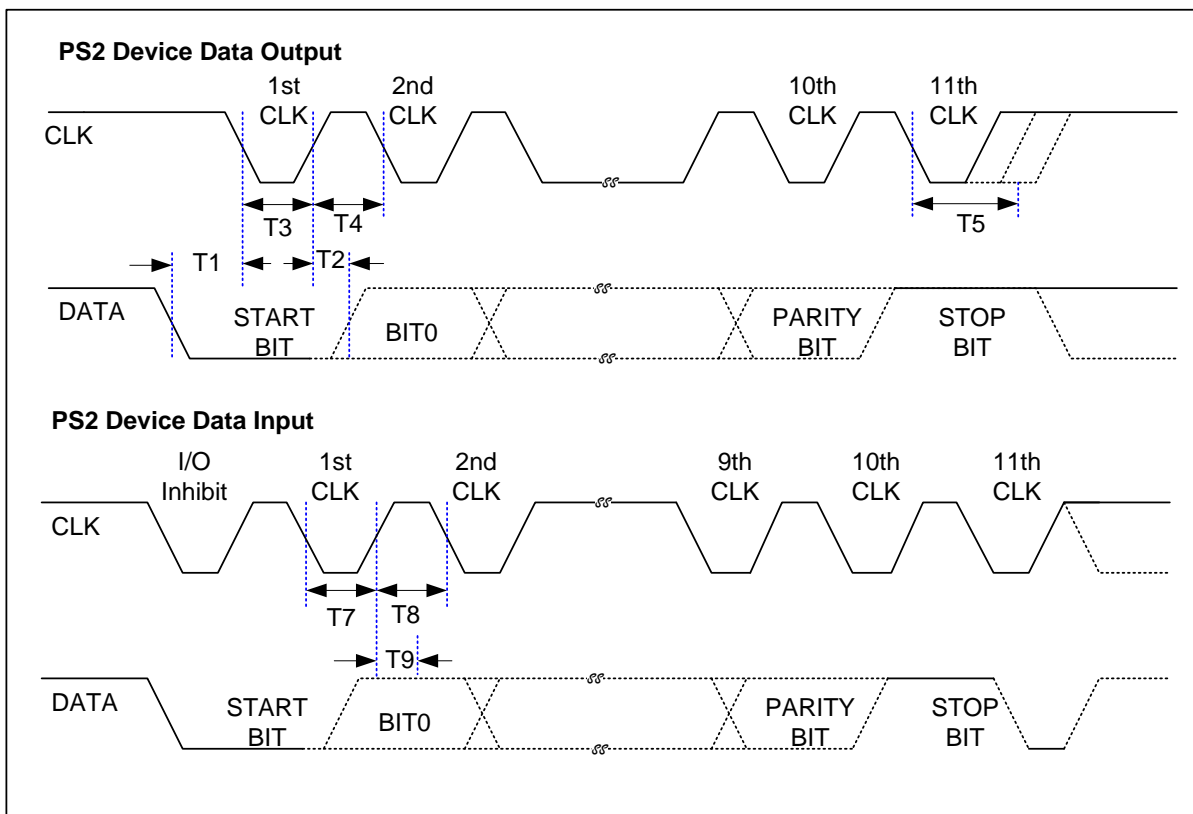

Figure 5-91 PS/2 Bus Timing



Symbol	Timing Parameter	MIN.	Max
T1	DATA transition to the falling edge of CLK	5us	25us
T2	Rising edge of CLK to DATA transition	5us	T4-5us
T3	Duration of CLK inactive	30us	50us
T4	Duration of CLK active	30us	50us
T5	Time to auxiliary device inhibit after 11 th clock to ensure auxiliary device does not start another transmission	>0	50us
T7	Duration of CLK inactive	30us	50us
T8	Duration of CLK active	30us	50us
T9	Time from inactive to active CLK transition, use to time auxiliary device sample DATA	5us	25us



5.14.4.3 TX FIFO Operation

Writing PS2TXDATA0 register starts device to host communication. S/W is required to define TXFIFO depth before writing transmission data to TX FIFO. 1st START bit is sent to PS/2 bus 100us after S/W writes TX FIFO, if there is more than 4 bytes data need to be sent, S/W can write residual data to PS2TXDATA1-3 before 4th byte transmit complete. A time delay 100us is added between two consecutive bytes.

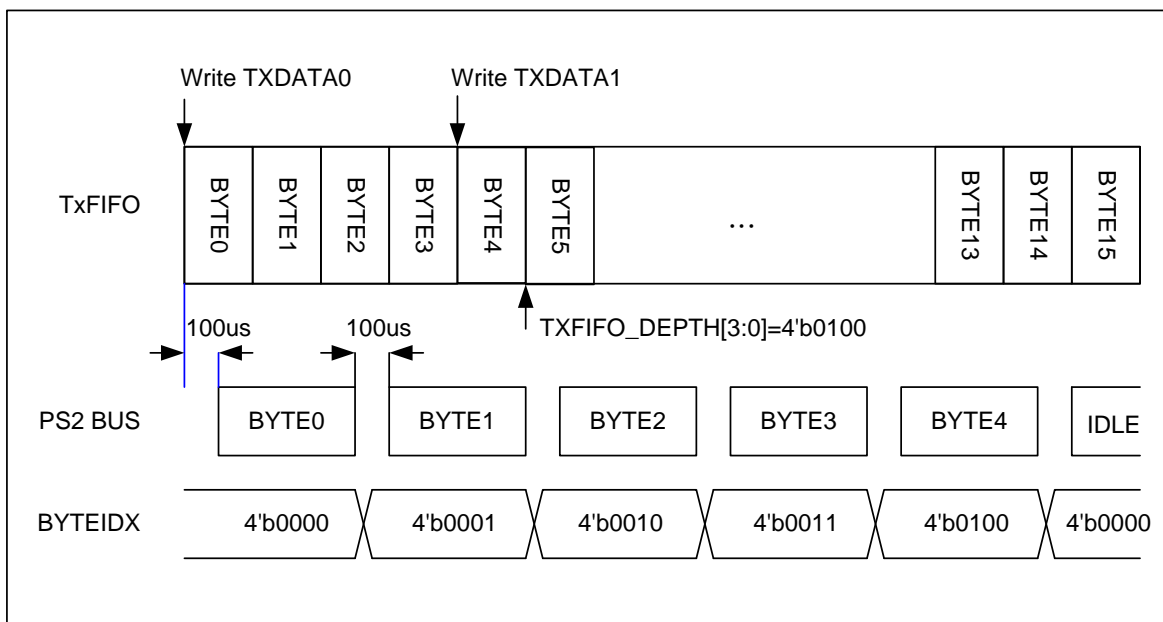

Figure 5-92 PS/2 Data Format



5.14.5 Register Map

R: read only, W: write only, R/W: both read and write

Register	Offset	R/W	Description	Reset Value
PS2 Base Address:				
PS2_BA = 0x4010_0000				
PS2CON	PS2_BA+0x00	R/W	PS/2 Control Register	0x0000_0000
PS2TXDATA0	PS2_BA+0x04	R/W	PS/2 Transmit Data Register 0	0x0000_0000
PS2TXDATA1	PS2_BA+0x08	R/W	PS/2 Transmit Data Register 1	0x0000_0000
PS2TXDATA2	PS2_BA+0x0C	R/W	PS/2 Transmit Data Register 2	0x0000_0000
PS2TXDATA3	PS2_BA+0x10	R/W	PS/2 Transmit Data Register 3	0x0000_0000
PS2RXDATA	PS2_BA+0x14	R	PS/2 Receive Data Register	0x0000_0000
PS2STATUS	PS2_BA+0x18	R/W	PS/2 Status Register	0x0000_0083
PS2INTID	PS2_BA+0x1C	R/W	PS/2 Interrupt Identification Register	0x0000_0000



5.14.6 Register Description

PS/2 Control Register (PS2CON)

Register	Offset	R/W	Description	Reset Value
PS2CON	PS2_BA+0x00	R/W	PS/2 Control Register	0x0000_0000

31	30	29	28	27	26	25	24
Reserved							
23	22	21	20	19	18	17	16
Reserved							
15	14	13	12	11	10	9	8
Reserved				FPS2DAT	FPS2CLK	OVERRIDE	CLR_FIFO
7	6	5	4	3	2	1	0
ACK	TX_FIFO_DEPTH				RXINTEN	TXINTEN	PS2EN

Bits	Description	
[31:12]	Reserved	Reserved
[11]	FPS2DAT	<p>Force PS2DATA Line</p> <p>It forces PS2DATA high or low regardless of the internal state of the device controller if OVERRIDE is set to high.</p> <p>1 = Force PS2DATA high 0 = Force PS2DATA low</p>
[10]	FPS2CLK	<p>Force PS2CLK Line</p> <p>It forces PS2CLK line high or low regardless of the internal state of the device controller if OVERRIDE is set to high.</p> <p>1 = Force PS2CLK line high 0 = Force PS2CLK line low</p>
[9]	OVERRIDE	<p>Software Override PS/2 CLK/DATA Pin State</p> <p>1 = PS2CLK and PS2DATA pins are controlled by S/W 0 = PS2CLK and PS2DATA pins are controlled by internal state machine.</p>
[8]	CLR_FIFO	<p>Clear TX FIFO</p> <p>Write 1 to this bit to terminate device to host transmission. The TXEMPTY bit in PS2STATUS bit will be set to 1 and pointer BYTEIDEX is reset to 0 regardless there is residue data in buffer or not. The buffer content is not been cleared.</p> <p>1 = Clear FIFO 0 = Not active</p>
[7]	ACK	<p>Acknowledge Enable</p> <p>1 = If parity error or stop bit is not received correctly, acknowledge bit will not be sent to host at 12th clock</p>



		0 = Always send acknowledge to host at 12th clock for host to device communication.
[6:3]	TXFIFODIPTH	Transmit Data FIFO Depth There is 16 bytes buffer for data transmit. S/W can define the FIFO depth from 1 to 16 bytes depends on application. 0 = 1 byte 1 = 2 bytes ... 14 = 15 bytes 15 = 16 bytes
[2]	RXINTEN	Enable Receive Interrupt 1 = Data receive complete interrupt Enabled 0 = Data receive complete interrupt Disabled
[1]	TXINTEN	Enable Transmit Interrupt 1 = Data transmit complete interrupt Enabled 0 = Data transmit complete interrupt Disabled
[0]	PS2EN	Enable PS/2 Device Enable PS/2 device controller 1 = Enabled 0 = Disabled



PS/2 TX DATA Register 0-3 (PS2TXDATA0-3)

Register	Offset	R/W	Description	Reset Value
PS2TXDATA0	PS2_BA+0x04	R/W	PS/2 Transmit Data Register 0	0x0000_0000
PS2TXDATA1	PS2_BA+0x08	R/W	PS/2 Transmit Data Register 1	0x0000_0000
PS2TXDATA2	PS2_BA+0x0C	R/W	PS/2 Transmit Data Register 2	0x0000_0000
PS2TXDATA3	PS2_BA+0x10	R/W	PS/2 Transmit Data Register 3	0x0000_0000

31	30	29	28	27	26	25	24
PS2TXDATAx[31:24]							
23	22	21	20	19	18	17	16
PS2TXDATAx[23:16]							
15	14	13	12	11	10	9	8
PS2TXDATAx[15:8]							
7	6	5	4	3	2	1	0
PS2TXDATAx[7:0]							

Bits	Description	
[31:0]	PS2TXDATAx	<p>Transmit data</p> <p>Write data to this register starts device to host communication if bus is in IDLE state. S/W must enable PS2EN before writing data to TX buffer.</p>



PS/2 Receiver DATA Register (PS2RXDATA)

Register	Offset	R/W	Description	Reset Value
PS2RXDATA	PS2_BA+0x14	R	PS/2 Receive Data Register	0x0000_0000

31	30	29	28	27	26	25	24
Reserved							
23	22	21	20	19	18	17	16
Reserved							
15	14	13	12	11	10	9	8
Reserved							
7	6	5	4	3	2	1	0
RXDATA[7:0]							

Bits	Description	
[31:8]	Reserved	Reserved
[7:0]	PS2RXDATA	Received Data For host to device communication, after acknowledge bit is sent, the received data is copied from receive shift register to PS2RXDATA register. CPU must read this register before next byte reception complete, otherwise the data will be overwritten and RXOVF bit in PS2STATUS[6] will be set to 1.



PS/2 Status Register (PS2STATUS)

Register	Offset	R/W	Description	Reset Value
PS2STATUS	PS2_BA+0x18	R/W	PS/2 Status Register	0x0000_0083

31	30	29	28	27	26	25	24
Reserved							
23	22	21	20	19	18	17	16
Reserved							
15	14	13	12	11	10	9	8
Reserved				BYTEIDX[3:0]			
7	6	5	4	3	2	1	0
TXEMPTY	RXOVF	TXBUSY	RXBUSY	RXPARTY	FRAMERR	PS2DATA	PS2CLK

Bits	Description																																				
[31:12]	Reserved Reserved																																				
[11:8]	<p>Byte Index</p> <p>It indicates which data byte in transmit data shift register. When all data in FIFO is transmitted and it will be cleared to 0.</p> <p>The bits are read only.</p> <table border="1" style="width: 100%; text-align: center;"> <thead> <tr> <th>BYTEIDX</th> <th>DATA Transmit</th> <th>BYTEIDX</th> <th>DATA Transmit</th> </tr> </thead> <tbody> <tr> <td>0000</td> <td>TXDATA0[7:0]</td> <td>1000</td> <td>TXDATA2[7:0]</td> </tr> <tr> <td>0001</td> <td>TXDATA0[15:8]</td> <td>1001</td> <td>TXDATA2[15:8]</td> </tr> <tr> <td>0010</td> <td>TXDATA0[23:16]</td> <td>1010</td> <td>TXDATA2[23:16]</td> </tr> <tr> <td>0011</td> <td>TXDATA0[31:24]</td> <td>1011</td> <td>TXDATA2[31:24]</td> </tr> <tr> <td>0100</td> <td>TXDATA1[7:0]</td> <td>1100</td> <td>TXDATA3[7:0]</td> </tr> <tr> <td>0101</td> <td>TXDATA1[15:8]</td> <td>1101</td> <td>TXDATA3[15:8]</td> </tr> <tr> <td>0110</td> <td>TXDATA1[23:16]</td> <td>1110</td> <td>TXDATA3[23:16]</td> </tr> <tr> <td>0111</td> <td>TXDATA1[31:24]</td> <td>1111</td> <td>TXDATA3[31:24]</td> </tr> </tbody> </table>	BYTEIDX	DATA Transmit	BYTEIDX	DATA Transmit	0000	TXDATA0[7:0]	1000	TXDATA2[7:0]	0001	TXDATA0[15:8]	1001	TXDATA2[15:8]	0010	TXDATA0[23:16]	1010	TXDATA2[23:16]	0011	TXDATA0[31:24]	1011	TXDATA2[31:24]	0100	TXDATA1[7:0]	1100	TXDATA3[7:0]	0101	TXDATA1[15:8]	1101	TXDATA3[15:8]	0110	TXDATA1[23:16]	1110	TXDATA3[23:16]	0111	TXDATA1[31:24]	1111	TXDATA3[31:24]
BYTEIDX	DATA Transmit	BYTEIDX	DATA Transmit																																		
0000	TXDATA0[7:0]	1000	TXDATA2[7:0]																																		
0001	TXDATA0[15:8]	1001	TXDATA2[15:8]																																		
0010	TXDATA0[23:16]	1010	TXDATA2[23:16]																																		
0011	TXDATA0[31:24]	1011	TXDATA2[31:24]																																		
0100	TXDATA1[7:0]	1100	TXDATA3[7:0]																																		
0101	TXDATA1[15:8]	1101	TXDATA3[15:8]																																		
0110	TXDATA1[23:16]	1110	TXDATA3[23:16]																																		
0111	TXDATA1[31:24]	1111	TXDATA3[31:24]																																		
[7]	<p>TXEMPTY</p> <p>TX FIFO Empty</p> <p>When S/W writes any data to PS2TXDATA0-3 the TXEMPTY bit is cleared to 0 immediately if PS2EN is enabled. When transmitted data byte number is equal to FIFODEPTH then TXEMPTY bit is set to 1.</p> <p>1 = FIFO is empty 0 = There is data to be transmitted</p> <p>This bit is read only.</p>																																				
[6]	<p>RXOVF</p> <p>RX Buffer Overwrite</p>																																				



		<p>1 = Data in PS2RXDATA register is overwritten by new received data</p> <p>0 = No overwrite</p> <p>Write 1 to clear this bit.</p>
[5]	TXBUSY	<p>Transmit Busy</p> <p>This bit indicates that the PS/2 device is currently sending data.</p> <p>1 = Currently sending data</p> <p>0 = Idle</p> <p>Read only bit.</p>
[4]	RXBUSY	<p>Receive Busy</p> <p>This bit indicates that the PS/2 device is currently receiving data.</p> <p>1 = Currently receiving data</p> <p>0 = Idle</p> <p>Read only bit.</p>
[3]	RXPARTY	<p>Received Parity</p> <p>This bit reflects the parity bit for the last received data byte (odd parity).</p> <p>Read only bit.</p>
[2]	FRAMERR	<p>Frame Error</p> <p>For host to device communication, if STOP bit (logic 1) is not received it is a frame error. If frame error occurs, DATA line may keep at low state after 12th clock. At this moment, S/W overrides PS2CLK to send clock till PS2DATA release to high state. After that, device sends a "Resend" command to host.</p> <p>1 = Frame error occur</p> <p>0 = No frame error</p> <p>Write 1 to clear this bit.</p>
[1]	PS2DATA	<p>DATA Pin State</p> <p>This bit reflects the status of the PS2DATA line after synchronizing and sampling.</p>
[0]	PS2CLK	<p>CLK Pin State</p> <p>This bit reflects the status of the PS2CLK line after synchronizing.</p>



PS/2 Interrupt Identification Register (PS2INTID)

Register	Offset	R/W	Description	Reset Value
PS2INTID	PS2_BA+0x1C	R/W	PS/2 Interrupt Identification Register	0x0000_0000

31	30	29	28	27	26	25	24
Reserved							
23	22	21	20	19	18	17	16
Reserved							
15	14	13	12	11	10	9	8
Reserved							
7	6	5	4	3	2	1	0
Reserved						TXINT	RXINT

Bits	Description	
[31:3]	Reserved	Reserved
[1]	TXINT	<p>Transmit Interrupt</p> <p>This bit is set to 1 after STOP bit is transmitted. Interrupt occur if TXINTEN bit is set to 1.</p> <p>1 = Transmit interrupt occurs</p> <p>0 = No interrupt</p> <p>Write 1 to clear this bit to 0.</p>
[0]	RXINT	<p>Receive Interrupt</p> <p>This bit is set to 1 when acknowledge bit is sent for Host to device communication. Interrupt occurs if RXINTEN bit is set to 1.</p> <p>1 = Receive interrupt occurs</p> <p>0 = No interrupt</p> <p>Write 1 to clear this bit to 0.</p>



5.15 I²S Controller (I²S)

5.15.1 Overview

The I²S controller consists of IIS protocol to interface with external audio CODEC. Two 8 word deep FIFO for read path and write path respectively and is capable of handling 8 ~ 32 bit word sizes. DMA controller handles the data movement between FIFO and memory.

5.15.2 Features

- Operated as either master or slave
- Capable of handling 8-, 16-, 24- and 32-bit word sizes
- Mono and stereo audio data supported
- I²S and MSB justified data format supported
- Two 8 word FIFO data buffers are provided, one for transmit and one for receive
- Generates interrupt requests when buffer levels cross a programmable boundary
- Two DMA requests – one for transmitting and one for receiving



5.15.3 Block Diagram

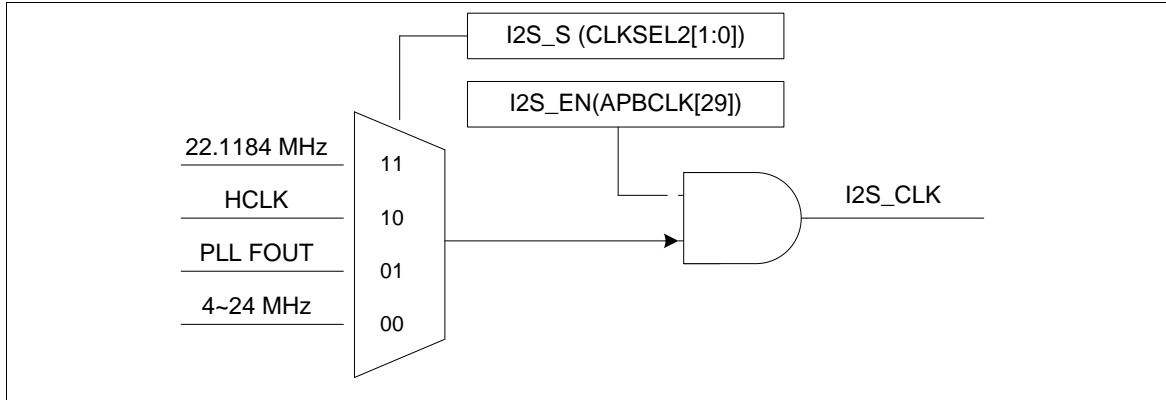

Figure 5-93 I²S Clock Control Diagram

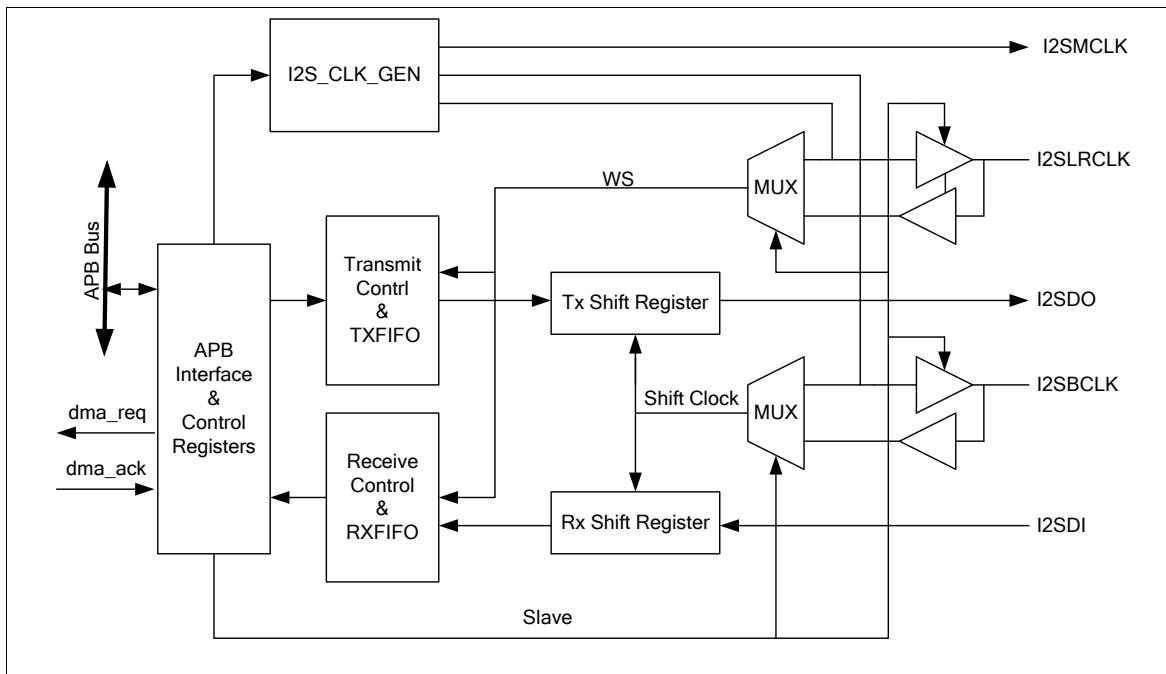

Figure 5-94 I²S Controller Block Diagram



5.15.4 Functional Description

5.15.4.1 I²S Operation

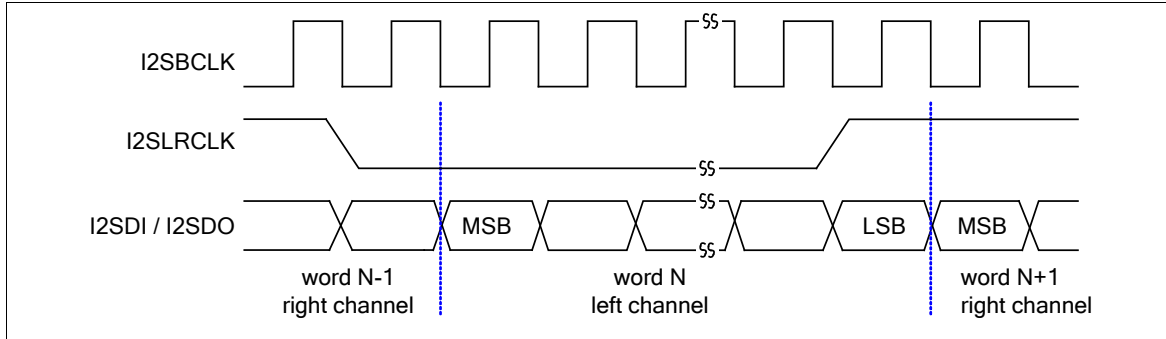

Figure 5-95 I²S Bus Timing Diagram (Format=0)

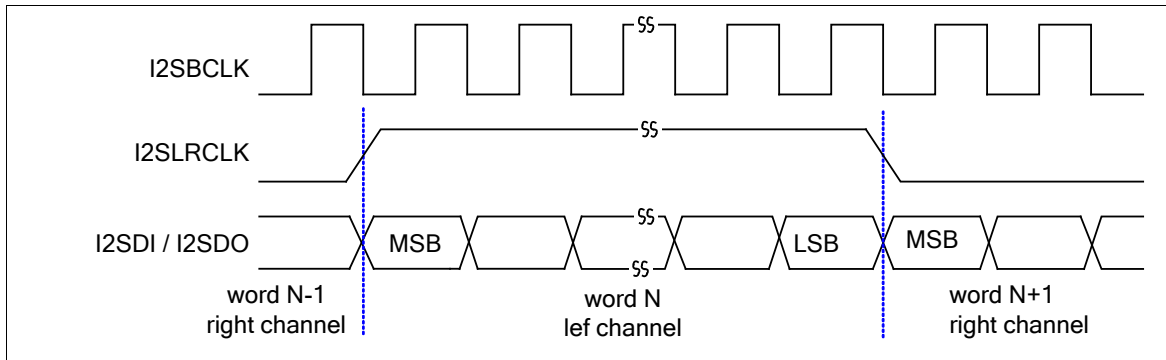

Figure 5-96 MSB Justified Timing Diagram (Format=1)



5.15.4.2 FIFO operation

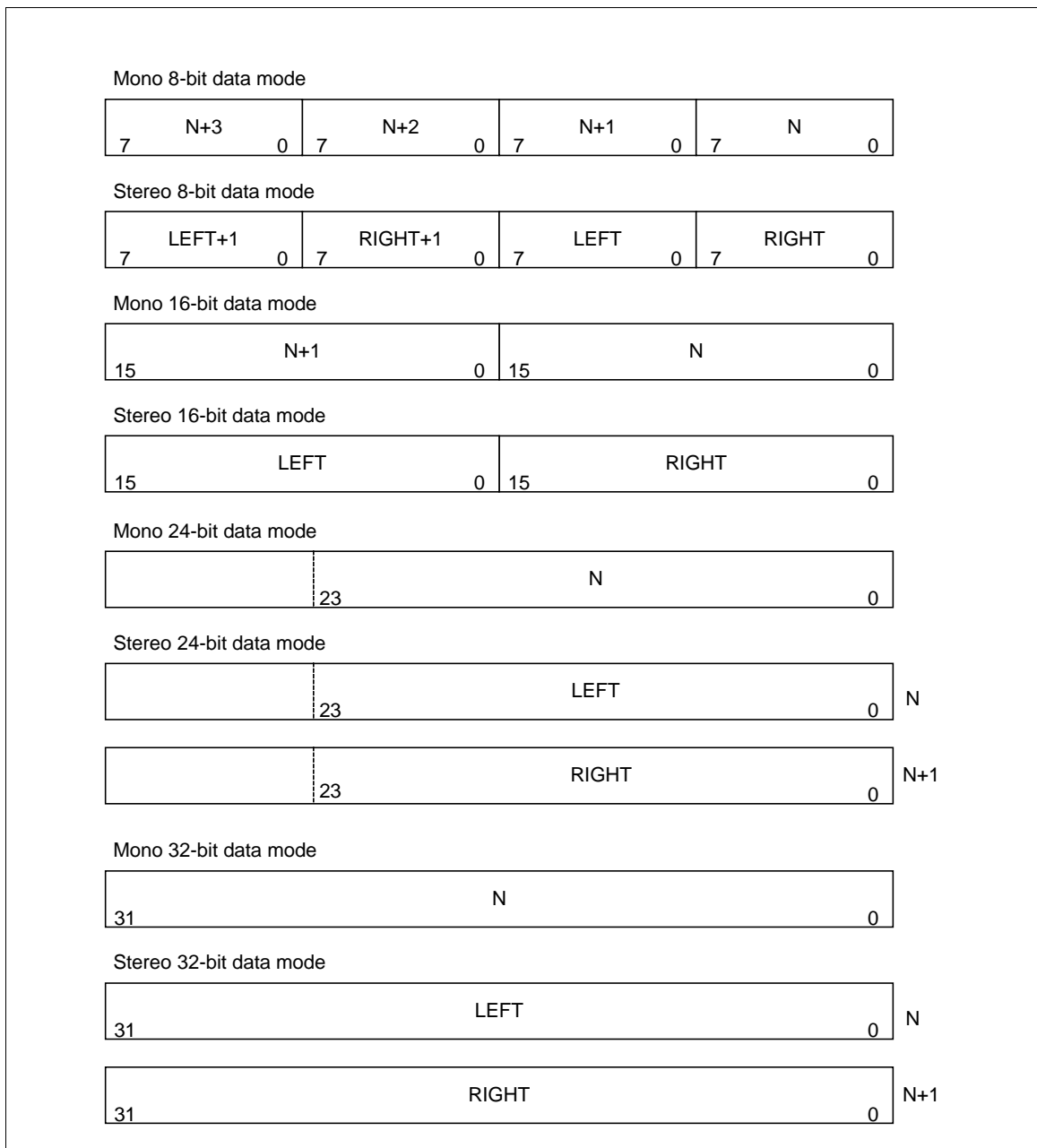

Figure 5-97 FIFO contents for various I²S modes



5.15.5 Register Map

R: read only, W: write only, R/W: both read and write

Register	Offset	R/W	Description	Reset Value
I2S Base Address:				
I2S_BA = 0x401A_0000				
I2SCON	I2S_BA+0x00	R/W	I ² S Control Register	0x0000_0000
I2SCLKDIV	I2S_BA+0x04	R/W	I ² S Clock Divider Control Register	0x0000_0000
I2SIE	I2S_BA+0x08	R/W	I ² S Interrupt Enable Register	0x0000_0000
I2SSTATUS	I2S_BA+0x0C	R/W	I ² S Status Register	0x0014_1000
I2STXFIFO	I2S_BA+0x10	W	I ² S Transmit FIFO Register	0x0000_0000
I2SRXFIFO	I2S_BA+0x14	R	I ² S Receive FIFO Register	0x0000_0000



5.15.6 Register Description

I²S Control Register (I2SCON)

Register	Offset	R/W	Description	Reset Value
I2SCON	I2S_BA+0x00	R/W	I ² S Control Register	0x0000_0000

31	30	29	28	27	26	25	24
Reserved							
23	22	21	20	19	18	17	16
Reserved	Reserved	RXDMA	TXDMA	CLR_RXFIFO	CLR_TXFIFO	LCHZCEN	RCHZCEN
15	14	13	12	11	10	9	8
MCLKEN	RXTH[2:0]			TXTH[2:0]			SLAVE
7	6	5	4	3	2	1	0
FORMAT	MONO	WORDWIDTH		MUTE	RXEN	TXEN	I2SEN

Bits	Description	
[31:22]	Reserved	Reserved
[21]	RXDMA	<p>Enable Receive DMA</p> <p>When RX DMA is enabled, I²S requests DMA to transfer data from receive FIFO to SRAM if FIFO is not empty.</p> <p>1 = RX DMA Enabled 0 = RX DMA Disabled</p>
[20]	TXDMA	<p>Enable Transmit DMA</p> <p>When TX DMA is enables, I²S request DMA to transfer data from SRAM to transmit FIFO if FIFO is not full.</p> <p>1 = TX DMA Enabled 0 = TX DMA Disabled</p>
[19]	CLR_RXFIFO	<p>Clear Receive FIFO</p> <p>Write 1 to clear receive FIFO, internal pointer is reset to FIFO start point, and RXFIFO_LEVEL[3:0] returns to zero and receive FIFO becomes empty.</p> <p>This bit is cleared by hardware automatically, read it return 0.</p>
[18]	CLR_TXFIFO	<p>Clear Transmit FIFO</p> <p>Write 1 to clear transmit FIFO, internal pointer is reset to FIFO start point, and TXFIFO_LEVEL[3:0] returns to zero and transmit FIFO becomes empty but data in transmit FIFO is not changed.</p> <p>This bit is clear by hardware automatically, read it return 0.</p>



[17]	LCHZCEN	<p>Left Channel Zero-cross Detection Enable</p> <p>If this bit is set to 1, when left channel data sign bit change or next shift data bits are all zero then LZCF flag in I2SSTATUS register is set to 1.</p> <p>1 = Left channel zero cross detection Enabled 0 = Left channel zero cross detection Disabled</p>
[16]	RCHZCEN	<p>Right Channel Zero-cross Detection Enable</p> <p>If this bit is set to 1, when right channel data sign bit change or next shift data bits are all zero then RZCF flag in I2SSTATUS register is set to 1.</p> <p>1 = Right channel zero cross detection Enabled 0 = Right channel zero cross detection Disabled</p>
[15]	MCLKEN	<p>Master Vlock Enable</p> <p>In the NuMicro™ NUC100 series, external crystal clock is frequency $2^N \times 256\text{fs}$ software can program MCLK_DIV[2:0] in I2SCLKDIV register to get 256fs clock to audio codec chip.</p> <p>1 = Master clock Enabled 0 = Master clock Disabled</p>
[14:12]	RXTH	<p>Receive FIFO Threshold Level</p> <p>When received data word(s) in buffer is equal or higher than threshold level then RXTHF flag is set.</p> <p>000 = 1 word data in receive FIFO 001 = 2 word data in receive FIFO 010 = 3 word data in receive FIFO 011 = 4 word data in receive FIFO 100 = 5 word data in receive FIFO 101 = 6 word data in receive FIFO 110 = 7 word data in receive FIFO 111 = 8 word data in receive FIFO</p>
[11:9]	TXTH	<p>Transmit FIFO threshold level</p> <p>If remain data word (32 bits) in transmit FIFO is the same or less than threshold level then TXTHF flag is set.</p> <p>000 = 0 word data in transmit FIFO 001 = 1 word data in transmit FIFO 010 = 2 words data in transmit FIFO 011 = 3 words data in transmit FIFO 100 = 4 words data in transmit FIFO 101 = 5 words data in transmit FIFO 110 = 6 words data in transmit FIFO 111 = 7 words data in transmit FIFO</p>



[8]	SLAVE	<p>Slave mode</p> <p>I²S can operate as master or slave. For Master mode, I2S_BCLK and I2S_LRCLK pins are output mode and send bit clock from NuMicro™ NUC100 series to Audio CODEC chip. In Slave mode, I2S_BCLK and I2S_LRCLK pins are input mode and I2S_BCLK and I2S_LRCLK signals are received from outer Audio CODEC chip.</p> <p>1 = Slave mode 0 = Master mode</p>
[7]	FORMAT	<p>Data format</p> <p>1 = MSB justified data format 0 = I²S data format</p>
[6]	MONO	<p>Monaural Data</p> <p>1 = Data is monaural format 0 = Data is stereo format</p> <p>Note: when chip records data, only right channel data will be saved if monaural format is selected.</p>
[5:4]	WORDWIDTH	<p>Word Width</p> <p>00 = data is 8-bit 01 = data is 16-bit 10 = data is 24-bit 11 = data is 32-bit</p>
[3]	MUTE	<p>Transmit Mute Enable</p> <p>1 = Transmit channel zero 0 = Transmit data is shifted from buffer</p>
[2]	RXEN	<p>Receive Enable</p> <p>1 = Data receiving Enabled 0 = Data receiving Disabled</p>
[1]	TXEN	<p>Transmit Enable</p> <p>1 = Data transmit Enabled 0 = Data transmit Disabled</p>
[0]	I2SEN	<p>I²S Controller Enable</p> <p>1 = Enabled 0 = Disabled</p>



I²S Clock Divider (I2SCLKDIV)

Register	Offset	R/W	Description	Reset Value
I2SCLKDIV	I2S_BA+0x04	R/W	I ² S Clock Divider Control Register	0x0000_0000

31	30	29	28	27	26	25	24
Reserved							
23	22	21	20	19	18	17	16
Reserved							
15	14	13	12	11	10	9	8
BCLK_DIV [7:0]							
7	6	5	4	3	2	1	0
Reserved				MCLK_DIV[2:0]			

Bits	Description	
[31:16]	Reserved	Reserved
[15:8]	BCLK_DIV	<p>Bit Clock Divider</p> <p>If I²S operates in Master mode, bit clock is provided by NuMicro™ NUC100 series. Software can program these bits to generate sampling rate clock frequency.</p> $F_BCLK = F_I2SCLK / (2 \times (BCLK_DIV + 1))$
[7:3]	Reserved	Reserved
[2:0]	MCLK_DIV	<p>Master Clock Divider</p> <p>If chip external crystal frequency is $(2 \times MCLK_DIV) \times 256fs$ then software can program these bits to generate 256fs clock frequency to audio codec chip. If MCLK_DIV is set to 0, MCLK is the same as external clock input.</p> <p>For example, sampling rate is 24 kHz and chip external crystal clock is 12.288 MHz, set MCLK_DIV=1.</p> $F_MCLK = F_I2SCLK / (2 \times (MCLK_DIV)) \text{ (When MCLK_DIV is } \geq 1 \text{)}$ $F_MCLK = F_I2SCLK \text{ (When MCLK_DIV is set to 0)}$



I²S Interrupt Enable Register (I2SIE)

Register	Offset	R/W	Description	Reset Value
I2SIE	I2S_BA+0x08	R/W	I ² S Interrupt Enable Register	0x0000_0000

31	30	29	28	27	26	25	24
Reserved							
23	22	21	20	19	18	17	16
Reserved							
15	14	13	12	11	10	9	8
Reserved			LZCIE	RZCIE	TXTHIE	TXOVFIE	TXUDFIE
7	6	5	4	3	2	1	0
Reserved					RXTHIE	RXOVFIE	RXUDFIE

Bits	Description	
[31:13]	Reserved	Reserved
[12]	LZCIE	Left Channel Zero-cross Interrupt Enable Interrupt occur if this bit is set to 1 and left channel zero cross 1 = Interrupt Enabled 0 = Interrupt Disabled
[11]	RZCIE	Right Channel Zero-cross Interrupt Enable 1 = Interrupt Enabled 0 = Interrupt Disabled
[10]	TXTHIE	Transmit FIFO Threshold Level Interrupt Enable Interrupt occurs if this bit is set to 1 and data words in transmit FIFO is less than TXTH[2:0]. 1 = Interrupt Enabled 0 = Interrupt Disabled
[9]	TXOVFIE	Transmit FIFO Overflow Interrupt Enable Interrupt occurs if this bit is set to 1 and transmit FIFO overflow flag is set to 1 1 = Interrupt Enabled 0 = Interrupt Disabled
[8]	TXUDFIE	Transmit FIFO Underflow Interrupt Enable Interrupt occur if this bit is set to 1 and transmit FIFO underflow flag is set to 1. 1 = Interrupt Enabled 0 = Interrupt Disabled
[7:3]	Reserved	Reserved



[2]	RXTHIE	<p>Receive FIFO Threshold Level Interrupt Enable</p> <p>When data word in receive FIFO is equal or higher then RXTH[2:0] and the RXTHF bit is set to 1. If RXTHIE bit is enabled, interrupt occur.</p> <p>1 = Interrupt Enabled 0 = Interrupt Disabled</p>
[1]	RXOVFIE	<p>Receive FIFO Overflow Interrupt Enable</p> <p>1 = Interrupt Enabled 0 = Interrupt Disabled</p>
[0]	RXUDFIE	<p>Receive FIFO Underflow Interrupt Enable</p> <p>If software read receive FIFO when it is empty then RXUDF flag in I2SSTATUS register is set to 1.</p> <p>1 = Interrupt Enabled 0 = Interrupt Disabled</p>



I²S Status Register (I2SSTATUS)

Register	Offset	R/W	Description	Reset Value
I2SSTATUS	I2S_BA+0x0C	R/W	I ² S Status Register	0x0014_1000

31	30	29	28	27	26	25	24
TX_LEVEL[3:0]				RX_LEVEL[3:0]			
23	22	21	20	19	18	17	16
LZCF	RZCF	TXBUSY	TXEMPTY	TXFULL	TXTHF	TXOVF	TXUDF
15	14	13	12	11	10	9	8
Reserved			RXEMPTY	RXFULL	RXTHF	RXOVF	RXUDF
7	6	5	4	3	2	1	0
Reserved				RIGHT	I2STXINT	I2SRXINT	I2SINT

Bits	Description
[31:28]	<p>TX_LEVEL</p> <p>Transmit FIFO level These bits indicate word number in transmit FIFO 0000 = No data 0001 = 1 word in transmit FIFO 1000 = 8 words in transmit FIFO</p>
[27:24]	<p>RX_LEVEL</p> <p>Receive FIFO level These bits indicate word number in receive FIFO 0000 = No data 0001 = 1 word in receive FIFO 1000 = 8 words in receive FIFO</p>
[23]	<p>LZCF</p> <p>Left channel zero cross flag It indicates left channel next sample data sign bit is changed or all data bits are zero. 1 = Left channel zero cross is detected 0 = No zero cross Software can write 1 to clear this bit to 0</p>
[22]	<p>RZCF</p> <p>Right channel zero cross flag It indicates right channel next sample data sign bit is changed or all data bits are zero. 1 = Right channel zero cross is detected 0 = No zero cross Software can write 1 to clear this bit to 0</p>



[21]	TXBUSY	<p>Transmit Busy</p> <p>This bit is clear to 0 when all data in transmit FIFO and shift buffer is shifted out, and set to 1 when 1st data is load to shift buffer.</p> <p>1 = Transmit shift buffer is busy 0 = Transmit shift buffer is empty</p> <p>This bit is read only.</p>
[20]	TXEMPTY	<p>Transmit FIFO empty</p> <p>This bit reflect data word number in transmit FIFO is zero</p> <p>1 = Empty 0 = Not empty</p> <p>This bit is read only.</p>
[19]	TXFULL	<p>Transmit FIFO full</p> <p>This bit reflect data word number in transmit FIFO is 8</p> <p>1 = Full. 0 = Not full.</p> <p>This bit is read only</p>
[18]	TXTHF	<p>Transmit FIFO threshold flag</p> <p>When data word(s) in transmit FIFO is equal or lower than threshold value set in TXTH[2:0] the TXTHF bit becomes to 1. It keeps at 1 till TXFIFO_LEVEL[3:0] is higher than TXTH[1:0] after software write TXFIFO register.</p> <p>1 = Data word(s) in FIFO is equal or lower than threshold level 0 = Data word(s) in FIFO is higher than threshold level</p> <p>This bit is read only</p>
[17]	TXOVF	<p>Transmit FIFO overflow flag</p> <p>Write data to transmit FIFO when it is full and this bit set to 1</p> <p>1 = Overflow 0 = No overflow</p> <p>Software can write 1 to clear this bit to 0</p>
[16]	TXUDF	<p>Transmit FIFO underflow flag</p> <p>When transmit FIFO is empty and shift logic hardware read data from data FIFO causes this set to 1.</p> <p>1 = Underflow 0 = No underflow</p> <p>Software can write 1 to clear this bit to 0</p>
[15:13]	Reserved	Reserved
[12]	RXEMPTY	<p>Receive FIFO empty</p> <p>This bit reflects data words number in receive FIFO is zero</p> <p>1 = Empty 0 = Not empty</p> <p>This bit is read only.</p>



[11]	RXFULL	<p>Receive FIFO full</p> <p>This bit reflect data words number in receive FIFO is 8</p> <p>1 = Full</p> <p>0 = Not full</p> <p>This bit is read only.</p>
[10]	RXTHF	<p>Receive FIFO threshold flag</p> <p>When data word(s) in receive FIFO is equal or higher than threshold value set in RXTH[2:0] the RXTHF bit becomes to 1. It keeps at 1 till RXFIFO_LEVEL[3:0] less than RXTH[1:0] after software read RXFIFO register.</p> <p>1 = Data word(s) in FIFO is equal or higher than threshold level</p> <p>0 = Data word(s) in FIFO is lower than threshold level</p> <p>This bit is read only</p>
[9]	RXOVF	<p>Receive FIFO overflow flag</p> <p>When receive FIFO is full and receive hardware attempt write to data into receive FIFO then this bit is set to 1, data in 1st buffer is overwrite.</p> <p>1 = Overflow occur</p> <p>0 = No overflow occur</p> <p>Software can write 1 to clear this bit to 0</p>
[8]	RXUDF	<p>Receive FIFO underflow flag</p> <p>Read receive FIFO when it is empty, this bit set to 1 indicate underflow occur.</p> <p>1 = Underflow occur</p> <p>0 = No underflow occur</p> <p>Software can write 1 to clear this bit to 0</p>
[7:4]	Reserved	Reserved
[3]	RIGHT	<p>Right channel</p> <p>This bit indicate current transmit data is belong to right channel</p> <p>1 = Right channel</p> <p>0 = Left channel</p> <p>This bit is read only</p>
[2]	I2STXINT	<p>I²S transmit interrupt</p> <p>1 = Transmit interrupt</p> <p>0 = No transmit interrupt</p> <p>This bit is read only</p>
[1]	I2SRXINT	<p>I²S receive interrupt</p> <p>1 = Receive interrupt</p> <p>0 = No receive interrupt</p> <p>This bit is read only</p>



[0]	I2SINT	<p>I²S Interrupt flag</p> <p>1 = I²S interrupt</p> <p>0 = No I²S interrupt</p> <p>It is wire-OR of I2STXINT and I2SRXINT bits.</p> <p>This bit is read only.</p>
-----	---------------	--



I²S Transmit FIFO (I2STXFIFO)

Register	Offset	R/W	Description	Reset Value
I2STXFIFO	I2S_BA+0x10	W	I ² S Transmit FIFO Register	0x0000_0000

31	30	29	28	27	26	25	24
TXFIFO[31:24]							
23	22	21	20	19	18	17	16
TXFIFO[23:16]							
15	14	13	12	11	10	9	8
TXFIFO[15:8]							
7	6	5	4	3	2	1	0
TXFIFO[7:0]							

Bits	Description	
[31:0]	TXFIFO	Transmit FIFO register I ² S contains 8 words (8x32 bit) data buffer for data transmit. Write data to this register to prepare data for transmit. The remain word number is indicated by TX_LEVEL[3:0] in I2SSTATUS



I²S Receive FIFO (I2SRXFIFO)

Register	Offset	R/W	Description	Reset Value
I2SRXFIFO	I2S_BA+0x14	R	I ² S Receive FIFO Register	0x0000_0000

31	30	29	28	27	26	25	24
RXFIFO[31:24]							
23	22	21	20	19	18	17	16
RXFIFO[23:16]							
15	14	13	12	11	10	9	8
RXFIFO[15:8]							
7	6	5	4	3	2	1	0
RXFIFO[7:0]							

Bits	Description	
[31:0]	RXFIFO	<p>Receive FIFO register</p> <p>I²S contains 8 words (8x32 bit) data buffer for data receive. Read this register to get data in FIFO. The remaining data word number is indicated by RX_LEVEL[3:0] in I2SSTATUS register.</p>



5.16 Analog-to-Digital Converter (ADC)

5.16.1 Overview

The NuMicro™ NUC100 Series contains one 12-bit successive approximation analog-to-digital converters (SAR A/D converter) with 8 input channels. The A/D converter supports three operation modes: single, single-cycle scan and continuous scan mode. The A/D converters can be started by software and external STADC pin.

5.16.2 Features

- Analog input voltage range: $0 \sim V_{REF}$
- 12-bit resolution and 10-bit accuracy is guaranteed
- Up to 8 single-end analog input channels or 4 differential analog input channels
- Maximum ADC clock frequency is 16 MHz
- Up to 700K SPS conversion rate
- Three operating modes
 - Single mode: A/D conversion is performed one time on a specified channel
 - Single-cycle scan mode: A/D conversion is performed one cycle on all specified channels with the sequence from the lowest numbered channel to the highest numbered channel
 - Continuous scan mode: A/D converter continuously performs Single-cycle scan mode until software stops A/D conversion
- An A/D conversion can be started by
 - Software write 1 to ADST bit
 - External pin STADC
- Conversion results are held in data registers for each channel with valid and overrun indicators
- Conversion result can be compared with specify value and user can select whether to generate an interrupt when conversion result is equal to the compare register setting
- Channel 7 supports 3 input sources: external analog voltage, internal band-gap voltage, and internal temperature sensor output
- Support Self-calibration to minimize conversion error

5.16.3 Block Diagram

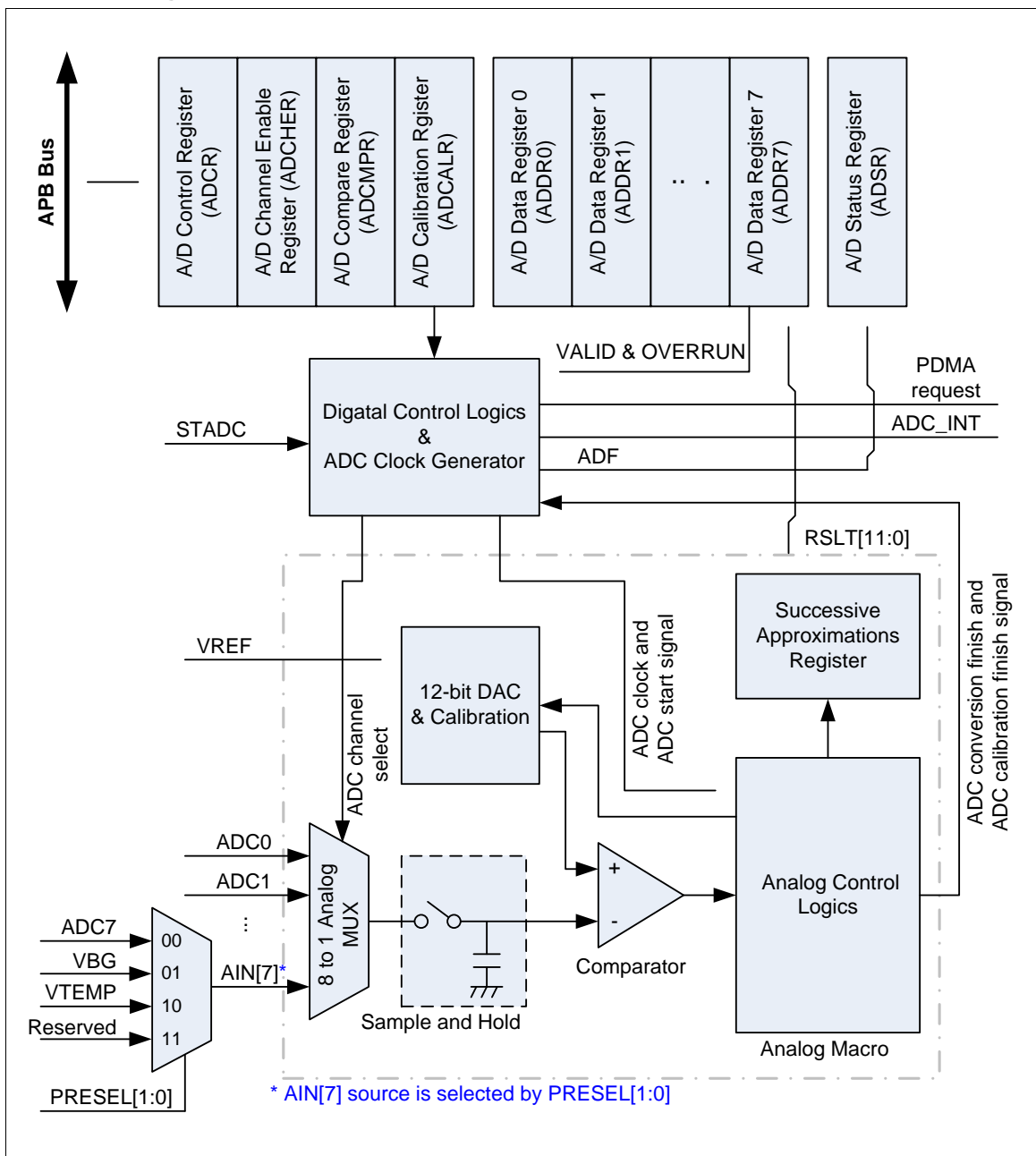

Figure 5-98 ADC Controller Block Diagram

5.16.4 Functional Description

The A/D converter operates by successive approximation with 12-bit resolution. This A/D converter is equipped with self-calibration function to minimize conversion error, user can write 1 to CALEN bit in ADCALR register to enable calibration function, while internal calibration is finished the CAL_DONE bit will be set to 1 by hardware. The ADC has three operation modes: single mode, single-cycle scan mode and continuous scan mode. When changing the operating mode or analog input channel, in order to prevent incorrect operation, software must clear ADST bit to 0 in ADCR register.

5.16.4.1 Self-Calibration

When chip power on or switch ADC input type between single-end input and differential input, it needs to do ADC self-calibration to minimize the conversion error. User can write 1 to CALEN bit of ADCALR register to start the self-calibration. It needs 127 ADC clocks to complete the calibration and the CAL_DONE bit will be set to 1 by hardware. The detail timing is shown below.

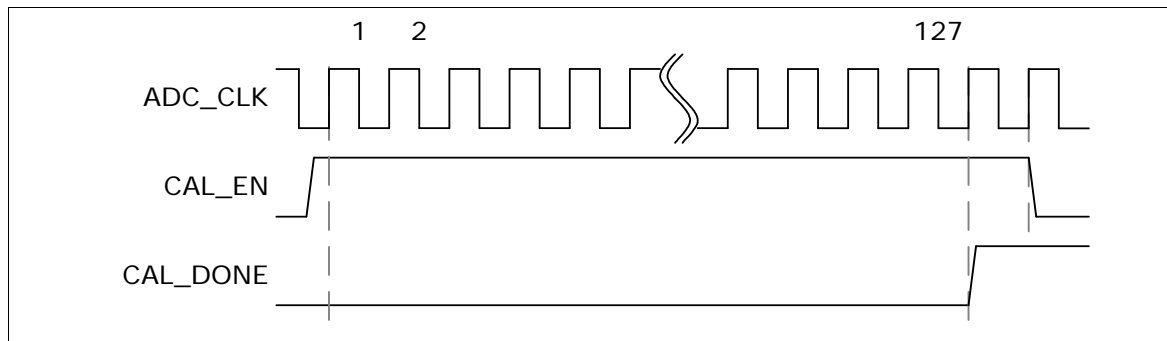

Figure 5-99 ADC Converter Self-Calibration Timing Diagram

5.16.4.2 ADC Clock Generator

The maximum sampling rate is up to 700K SPS. The ADC engine has four clock sources selected by 2-bit ADC_S (CLKSEL1[3:2]), the ADC clock frequency is divided by an 8-bit prescaler with the formula:

The ADC clock frequency = (ADC clock source frequency) / (ADC_N+1);

where the 8-bit ADC_N is located in register CLKDIV[23:16].

If the clock source is from HCLK, the ADC_N cannot be 0.

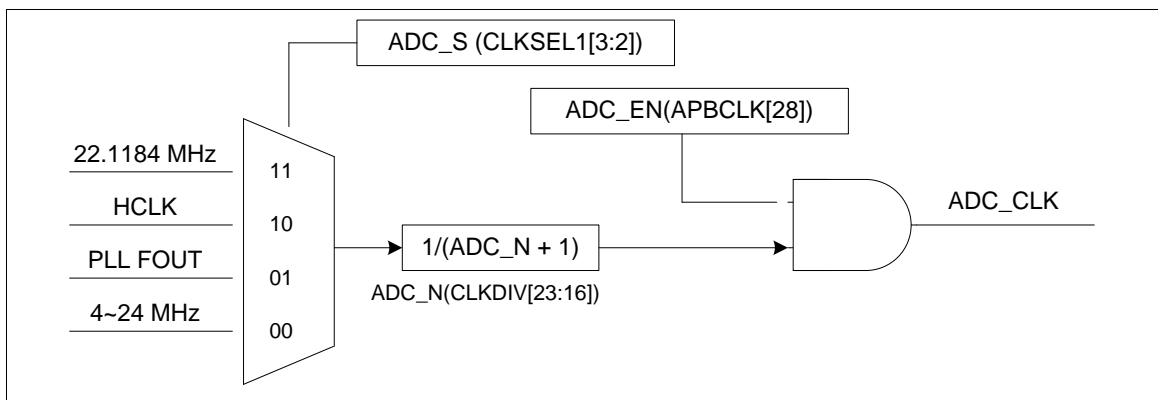

Figure 5-100 ADC Clock Control

5.16.4.3 Single Mode

In single mode, A/D conversion is performed only once on the specified single channel. The operations are as follows:

1. A/D conversion will be started when the ADST bit of ADCR is set to 1 by software or external trigger input.
2. When A/D conversion is finished, the result is stored in the A/D data register corresponding to the channel.
3. The ADF bit of ADSR register will be set to 1. If the ADIE bit of ADCR register is set to 1, the ADC interrupt will be asserted.
4. The ADST bit remains 1 during A/D conversion. When A/D conversion ends, the ADST bit is automatically cleared to 0 and the A/D converter enters idle state. Note that, after clearing the ADST bit, the ADST bit must be kept at 0 at least one ADC clock period before setting it to 1 again. If not, the A/D converter may not work.

Note: If software enables more than one channel in single mode, the channel with the lowest number will be selected and the other enabled channels will be ignored.

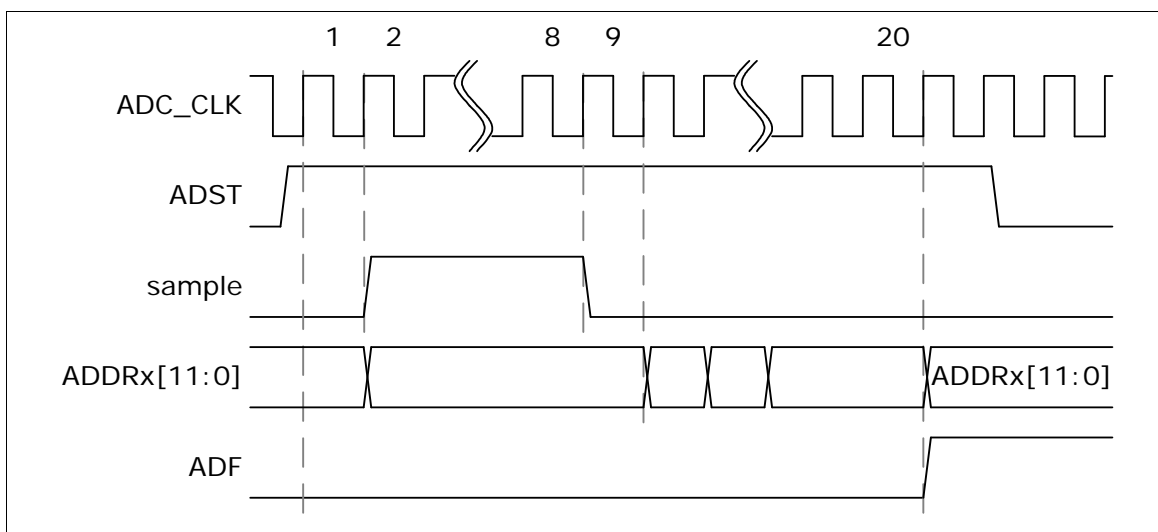

Figure 5-101 Single Mode Conversion Timing Diagram



5.16.4.4 Single-Cycle Scan Mode

In single-cycle scan mode, A/D conversion will sample and convert the specified channels once in the sequence from the lowest number enabled channel to the highest number enabled channel.

1. When the ADST bit of ADCR is set to 1 by software or external trigger input, A/D conversion starts on the channel with the lowest number.
2. When A/D conversion for each enabled channel is completed, the result is sequentially transferred to the A/D data register corresponding to each channel.
3. When the conversions of all the enabled channels are completed, the ADF bit in ADSR is set to 1. If the ADC interrupt function is enabled, the ADC interrupt occurs.
4. After A/D conversion ends, the ADST bit is automatically cleared to 0 and the A/D converter enters idle state. If ADST is cleared to 0 before all enabled ADC channels conversion done, ADC controller will finish current conversion and the result of the lowest enabled ADC channel will become unpredictable. Note that, after clearing the ADST bit to 0, the ADST bit must be kept at 0 at least one ADC clock period before setting it to 1 again. If not, the A/D converter may not work.

An example timing diagram for single-cycle scan on enabled channels (0, 2, 3 and 7) is shown below.

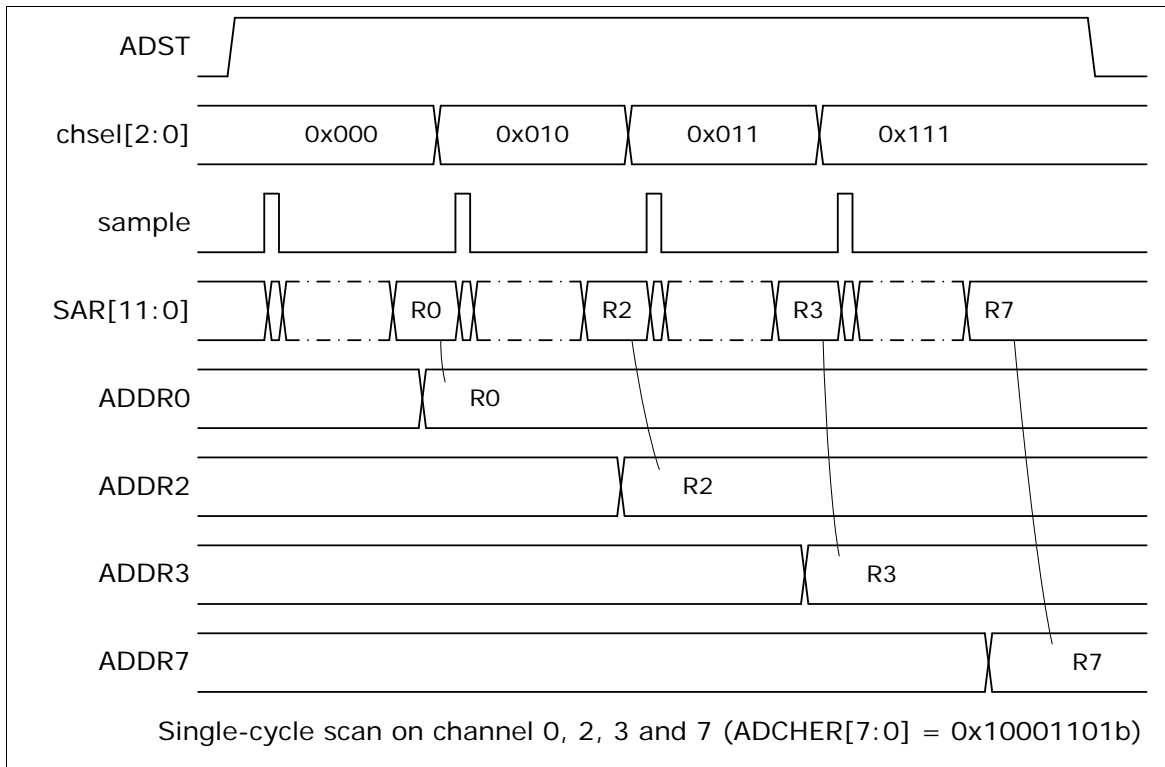

Figure 5-102 Single-Cycle Scan on Enabled Channels Timing Diagram

5.16.4.5 Continuous Scan Mode

In continuous scan mode, A/D conversion is performed sequentially on the specified channels that enabled by CHEN bits in ADCHER register (maximum 8 channels for ADC). The operations are as follows:

1. When the ADST bit in ADCR is set to 1 by software or external trigger input, A/D conversion starts on the channel with the lowest number.
2. When A/D conversion for each enabled channel is completed, the result of each enabled channel is stored in the A/D data register corresponding to each enabled channel.
3. When A/D converter completes the conversions of all enabled channels sequentially, the ADF bit (ADSR[0]) will be set to 1. If the ADC interrupt function is enabled, the ADC interrupt occurs. The conversion of the enabled channel with the lowest number will start again if software has not cleared the ADST bit.
4. As long as the ADST bit remains at 1, the step 2 ~ 3 will be repeated. When ADST is cleared to 0, ADC controller will finish current conversion and the result of the lowest enabled ADC channel will become unpredictable.

An example timing diagram for continuous scan on enabled channels (0, 2, 3 and 7) is shown below:

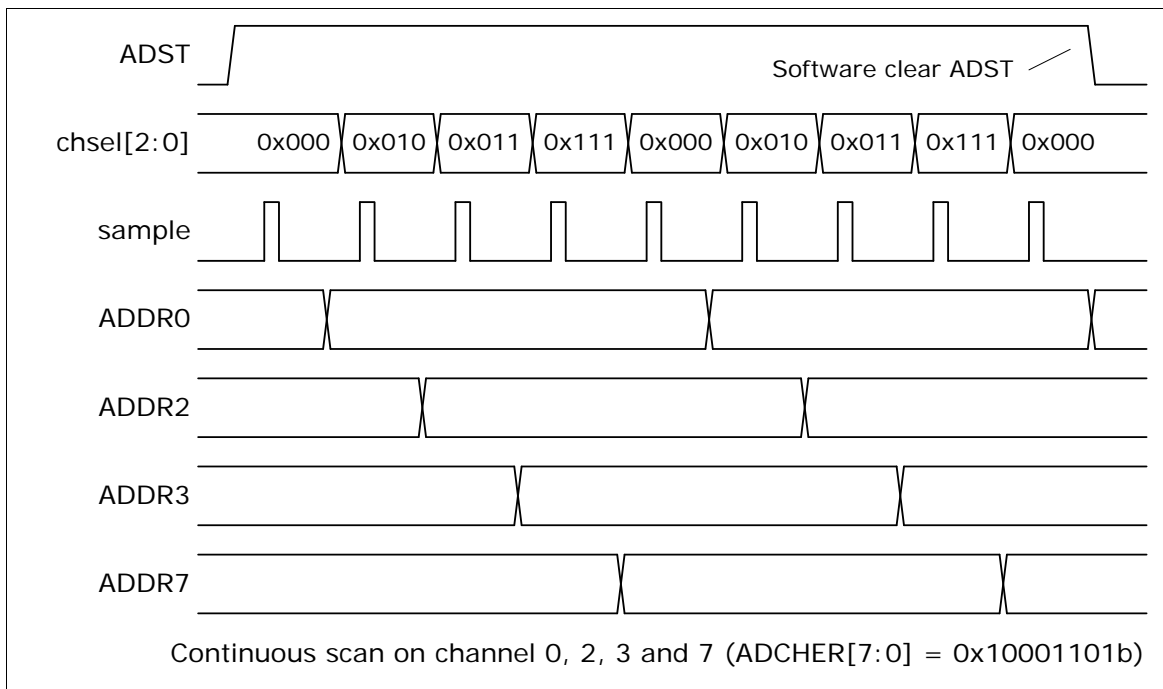

Figure 5-103 Continuous Scan on Enabled Channels Timing Diagram

5.16.4.6 External trigger Input Sampling and A/D Conversion Time

In single-cycle scan mode, A/D conversion can be triggered by external pin request. When the ADCR.TRGEN is set to high to enable ADC external trigger function, setting the TRGS[1:0] bits to 00b is to select external trigger input from the STADC pin. Software can set TRGCOND[1:0] to select trigger condition is falling/rising edge or low/high level. If level trigger condition is selected, the STADC pin must be kept at defined state at least 8 PCLKs. The ADST bit will be set to 1 at the 9th PCLK and start to conversion. Conversion is continuous if external trigger input is kept at

active state in level trigger mode. It is stopped only when external condition trigger condition disappears. If edge trigger condition is selected, the high and low state must be kept at least 4 PLCKs. Pulse that is shorter than this specification will be ignored.

5.16.4.7 Conversion Result Monitor by Compare Function

ADC controller provide two sets of compare register ADCMPR0 and ADCMPR1, to monitor maximum two specified channels conversion result from A/D conversion controller, refer to Figure 5-104. Software can select which channel to be monitored by set CMPCH(ADCMPRx[5:3]) and CMPCOND bit is used to check conversion result is less than specify value or greater than (equal to) value specified in CMPD[11:0]. When the conversion of the channel specified by CMPCH is completed, the comparing action will be triggered one time automatically. When the compare result meets the setting, compare match counter will increase 1, otherwise, the compare match counter will be clear to 0. When counter value reach the setting of (CMPMATCNT+1) then CMPF bit will be set to 1, if CMPIE bit is set then an ADC_INT interrupt request is generated. Software can use it to monitor the external analog input pin voltage transition in scan mode without imposing a load on software. Detail logics diagram is shown below.

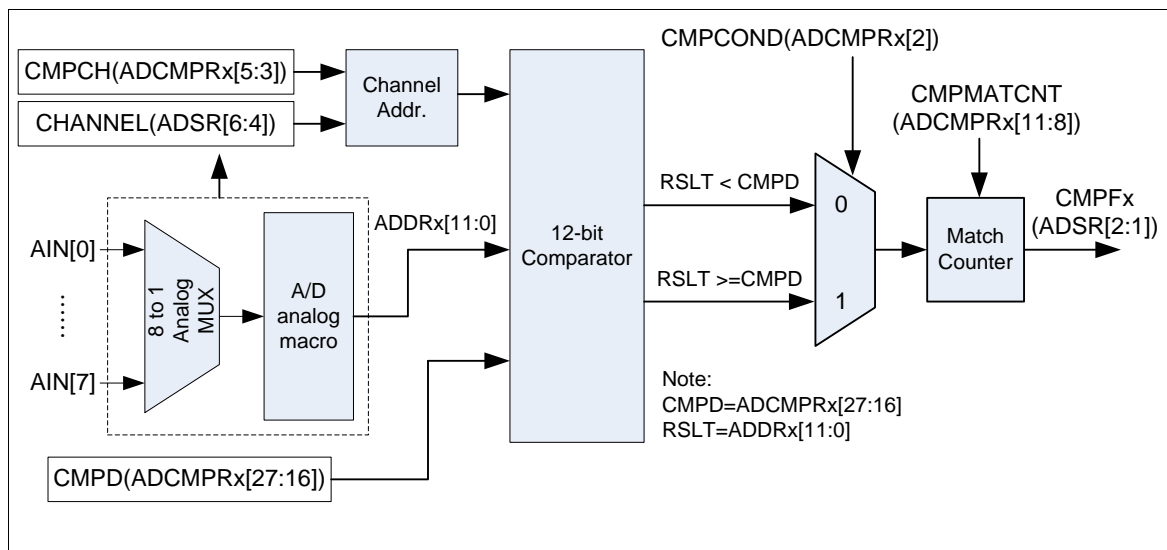

Figure 5-104 A/D Conversion Result Monitor Logics Diagram

5.16.4.8 Interrupt Sources

There are three interrupt sources of ADC interrupt. When an ADC operation mode finishes its conversion, the A/D conversion end flag, ADF, will be set to 1. The CMPF0 and CMPF1 are the compare flags of compare function. When the conversion result meets the settings of ADCMPR0/1, the corresponding flag will be set to 1. When one of the flags, ADF, CMPF0 and CMPF1, is set to 1 and the corresponding interrupt enable bit, ADIE of ADCR and CMP1E of ADCMPR0/1, is set to 1, the ADC interrupt will be asserted. Software can clear the flag to revoke the interrupt request.

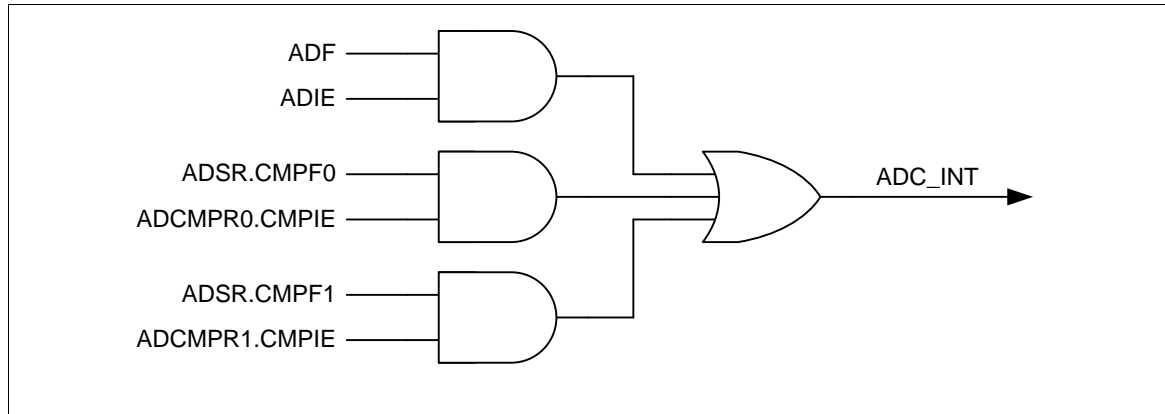

Figure 5-105 A/D Controller Interrupt

5.16.4.9 Peripheral DMA Request

When A/D conversion is finished, the conversion result will be loaded into ADDR register and VALID bit will be set to 1. If the PTEN bit of ADCR is set, ADC controller will generate a request to PDMA. User can use PDMA to transfer the conversion results to a user-specified memory space without CPU's intervention. The source address of PDMA operation is fixed at ADPDMA, no matter what channels was selected. When PDMA is transferring the conversion result, ADC will continue converting the next selected channel if the ADC operation mode is Single Scan mode or Continuous Scan mode. User can monitor current PDMA transfer data through reading ADPDMA register. If ADC completes the conversion of a selected channel and the last conversion result of the same channel has not been transferred by PDMA, OVERUN bit of the corresponding channel will be set and the last ADC conversion result will be overwrite by the new ADC conversion result. PDMA will transfer the latest data of selected channels to the user-specified destination address.



5.16.5 Register Map

R: read only, W: write only, R/W: both read and write

Register	Offset	R/W	Description	Reset Value
ADC Base Address:				
ADC_BA = 0x400E_0000				
ADDR0	ADC_BA+0x00	R	A/D Data Register 0	0x0000_0000
ADDR1	ADC_BA+0x04	R	A/D Data Register 1	0x0000_0000
ADDR2	ADC_BA+0x08	R	A/D Data Register 2	0x0000_0000
ADDR3	ADC_BA+0x0C	R	A/D Data Register 3	0x0000_0000
ADDR4	ADC_BA+0x10	R	A/D Data Register 4	0x0000_0000
ADDR5	ADC_BA+0x14	R	A/D Data Register 5	0x0000_0000
ADDR6	ADC_BA+0x18	R	A/D Data Register 6	0x0000_0000
ADDR7	ADC_BA+0x1C	R	A/D Data Register 7	0x0000_0000
ADCR	ADC_BA+0x20	R/W	A/D Control Register	0x0000_0000
ADCHER	ADC_BA+0x24	R/W	A/D Channel Enable Register	0x0000_0000
ADCMPR0	ADC_BA+0x28	R/W	A/D Compare Register 0	0x0000_0000
ADCMPR1	ADC_BA+0x2C	R/W	A/D Compare Register 1	0x0000_0000
ADSR	ADC_BA+0x30	R/W	A/D Status Register	0x0000_0000
ADCALR	ADC_BA+0x34	R/W	A/D Calibration Register	0x0000_0000
ADPDMA	ADC_BA+0x40	R	ADC PDMA current transfer data Register	0x0000_0000



5.16.6 Register Description

A/D Data Registers (ADDR0 ~ ADDR7)

Register	Offset	R/W	Description	Reset Value
ADDR0	ADC_BA+0x00	R	A/D Data Register 0	0x0000_0000
ADDR1	ADC_BA+0x04	R	A/D Data Register 1	0x0000_0000
ADDR2	ADC_BA+0x08	R	A/D Data Register 2	0x0000_0000
ADDR3	ADC_BA+0x0C	R	A/D Data Register 3	0x0000_0000
ADDR4	ADC_BA+0x10	R	A/D Data Register 4	0x0000_0000
ADDR5	ADC_BA+0x14	R	A/D Data Register 5	0x0000_0000
ADDR6	ADC_BA+0x18	R	A/D Data Register 6	0x0000_0000
ADDR7	ADC_BA+0x1C	R	A/D Data Register 7	0x0000_0000

31	30	29	28	27	26	25	24
Reserved							
23	22	21	20	19	18	17	16
Reserved						VALID	OVERRUN
15	14	13	12	11	10	9	8
RSLT [15:8]							
7	6	5	4	3	2	1	0
RSLT[7:0]							

Bits	Description
[31:18]	Reserved
[17]	<p>VALID</p> <p>Valid Flag 1 = Data in RSLT[15:0] bits is valid 0 = Data in RSLT[15:0] bits is not valid</p> <p>This bit is set to 1 when corresponding channel analog input conversion is completed and cleared by hardware after ADDR register is read.</p> <p>This bit is read only.</p>



[16]	OVERRUN	<p>Over Run Flag</p> <p>1 = Data in RSLT[15:0] is overwrite 0 = Data in RSLT[15:0] is recent conversion result</p> <p>If converted data in RSLT[15:0] has not been read before new conversion result is loaded to this register, OVERRUN is set to 1 and previous conversion result is gone. It is cleared by hardware after ADDR register is read.</p> <p>This bit is read only.</p>
[15:0]	RSLT	<p>A/D Conversion Result</p> <p>This field contains conversion result of ADC.</p> <p>When DMOF bit (ADCR[31]) set to 0, 12-bit ADC conversion result with unsigned format will be filled in RSLT[11:0] and zero will be filled in RSLT[15:12].</p> <p>When DMOF bit (ADCR[31]) set to 1, 12-bit ADC conversion result with 2's complement format will be filled in RSLT[11:0] and signed bits to will be filled in RSLT[15:12].</p>

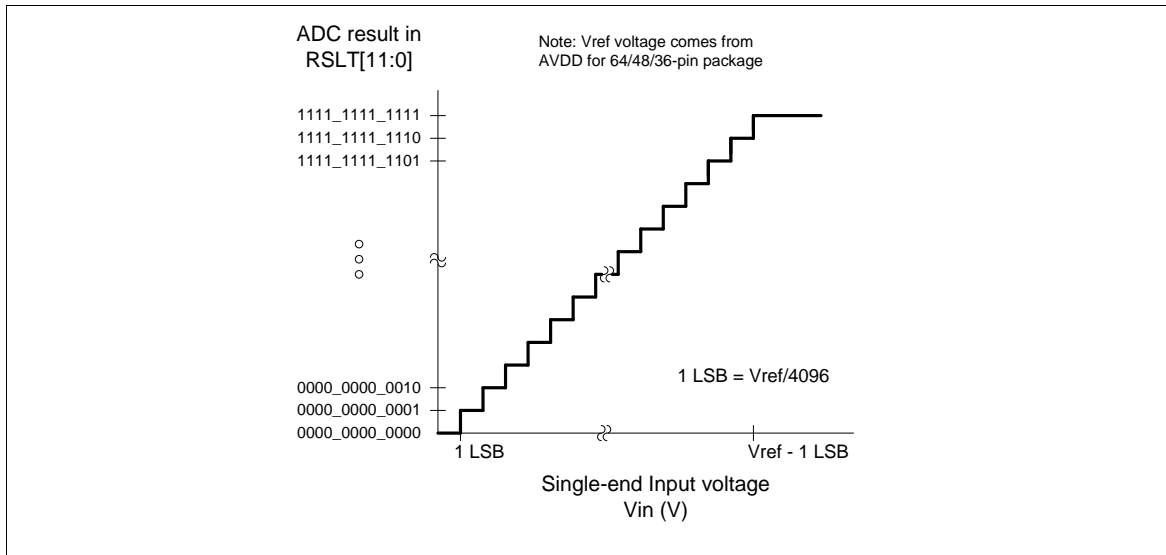

Figure 5-106 ADC Single-end Input Conversion Voltage and Conversion Result Mapping Diagram

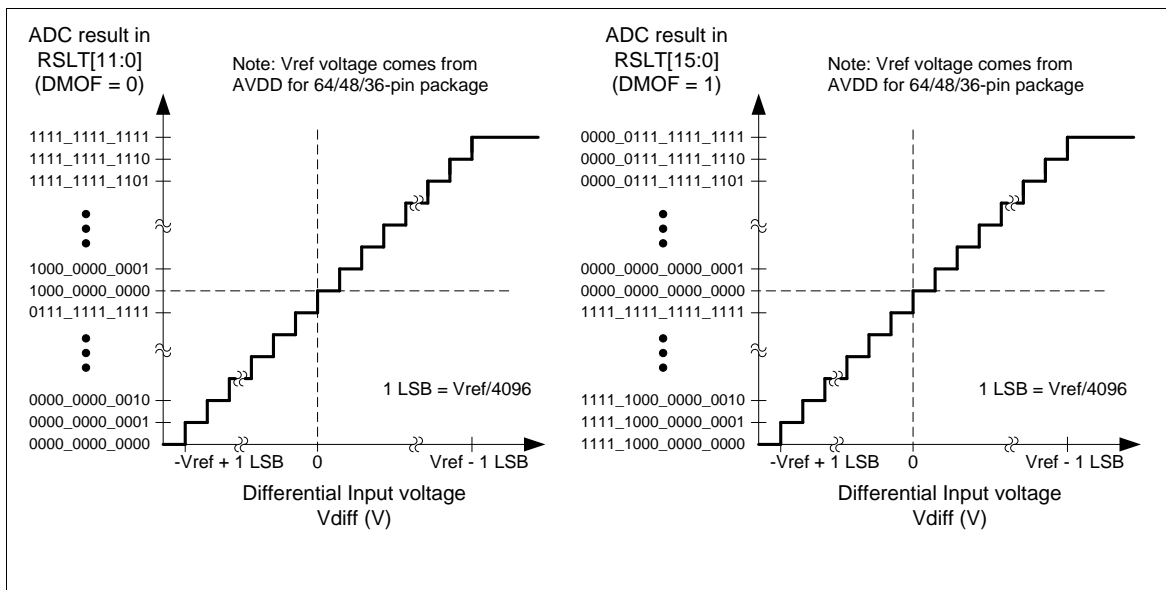

Figure 5-107 ADC Differential Input Conversion Voltage and Conversion Result Mapping Diagram



A/D Control Register (ADCR)

Register	Offset	R/W	Description	Reset Value
ADCR	ADC_BA+0x20	R/W	A/D Control Register	0x0000_0000

31	30	29	28	27	26	25	24
DMOF		Reserved					
23	22	21	20	19	18	17	16
Reserved							
15	14	13	12	11	10	9	8
Reserved				ADST	DIFFEN	PTEN	TRGEN
7	6	5	4	3	2	1	0
TRGCOND		TRGS		ADMD		ADIE	ADEN

Bits	Description	
[31]	DMOF	A/D differential input Mode Output Format 1 = A/D Conversion result will be filled in RSLT at ADDR _x registers with 2's complement format. 0 = A/D Conversion result will be filled in RSLT at ADDR _x registers with unsigned format.
[30:12]	Reserved	Reserved
[11]	ADST	A/D Conversion Start 1 = Conversion started 0 = Conversion stopped and A/D converter enter idle state ADST bit can be set to 1 from two sources: software and external pin STADC. ADST will be cleared to 0 by hardware automatically at the ends of single mode and single-cycle scan mode. In continuous scan mode, A/D conversion is continuously performed until software write 0 to this bit or chip reset.



[10]	DIFFEN	Differential Input Mode Enable 1 = Differential analog input mode 0 = Single-end analog input mode			
		Differential Input Paired Channel	ADC Analog Input		
			V_{plus}	V_{minus}	
		0	ADC0	ADC1	
		1	ADC2	ADC3	
		2	ADC4	ADC5	
		3	ADC6	ADC7	
Differential input voltage (V_{diff}) = $V_{plus} - V_{minus}$, where V_{plus} is the analog input; V_{minus} is the inverted analog input. In differential input mode, only the even number of the two corresponding channels needs to be enabled in ADCHER. The conversion result will be placed to the corresponding data register of the enabled channel.					
[9]	PTEN	PDMA Transfer Enable 1 = PDMA data transfer in ADDR 0 ~ 7 Enabled. 0 = PDMA data transfer Disabled. When A/D conversion is completed, the converted data is loaded into ADDR 0~7, software can enable this bit to generate a PDMA data transfer request. When PTEN=1, software must set ADIE=0 to disable interrupt.			
[8]	TRGEN	External Trigger Enable Enable or disable triggering of A/D conversion by external STADC pin. 1 = Enabled. 0 = Disabled. ADC external trigger function is only supported in single-cycle scan mode.			
[7:6]	TRGCOND	External Trigger Condition These two bits decide external pin STADC trigger event is level or edge. The signal must be kept at stable state at least 8 PCLKs for level trigger and 4 PCLKs at high and low state for edge trigger. 00 = Low level 01 = High level 10 = Falling edge 11 = Rising edge			
[5:4]	TRGS	Hardware Trigger Source 00 = A/D conversion is started by external STADC pin. Others = Reserved Software should disable TRGEN and ADST before change TRGS. In hardware trigger mode, the ADST bit is set by the external trigger from STADC.			



[3:2]	ADMD	<p>A/D Converter Operation Mode</p> <p>00 = Single conversion 01 = Reserved 10 = Single-cycle scan 11 = Continuous scan</p> <p>When changing the operation mode, software should disable ADST bit firstly.</p>
[1]	ADIE	<p>A/D Interrupt Enable</p> <p>1 = A/D interrupt function Enabled. 0 = A/D interrupt function Disabled.</p> <p>A/D conversion end interrupt request is generated if ADIE bit is set to 1.</p>
[0]	ADEN	<p>A/D Converter Enable</p> <p>1 = Enabled 0 = Disabled</p> <p>Before starting A/D conversion function, this bit should be set to 1. Clear it to 0 to disable A/D converter analog circuit for saving power consumption.</p>



A/D Channel Enable Register (ADCHER)

Register	Offset	R/W	Description	Reset Value
ADCHER	ADC_BA+0x24	R/W	A/D Channel Enable Register	0x0000_0000

31	30	29	28	27	26	25	24
Reserved							
23	22	21	20	19	18	17	16
Reserved							
15	14	13	12	11	10	9	8
Reserved						PRESEL[1:0]	
7	6	5	4	3	2	1	0
CHEN7	CHEN6	CHEN5	CHEN4	CHEN3	CHEN2	CHEN1	CHEN0

Bits	Description	
[31:10]	Reserved	Reserved
[9:8]	PRESEL	Analog Input Channel 7 Selection 00 = External analog input 01 = Internal band-gap voltage 10 = Internal temperature sensor 11 = Reserved Note: When software select the band-gap voltage as the analog input source of ADC channel 7, ADC clock rate needs to be limited to lower than 300 kHz.
[7]	CHEN7	Analog Input Channel 7 Enable 1 = Enabled 0 = Disabled
[6]	CHEN6	Analog Input Channel 6 Enable 1 = Enabled 0 = Disabled
[5]	CHEN5	Analog Input Channel 5 Enable 1 = Enabled 0 = Disabled
[4]	CHEN4	Analog Input Channel 4 Enable 1 = Enabled 0 = Disabled
[3]	CHEN3	Analog Input Channel 3 Enable 1 = Enabled 0 = Disabled



[2]	CHEN2	Analog Input Channel 2 Enable 1 = Enabled 0 = Disabled
[1]	CHEN1	Analog Input Channel 1 Enable 1 = Enabled 0 = Disabled
[0]	CHEN0	Analog Input Channel 0 Enable 1 = Enabled 0 = Disabled



A/D Compare Register 0/1 (ADCMR0/1)

Register	Offset	R/W	Description	Reset Value
ADCMR0	ADC_BA+0x28	R/W	A/D Compare Register 0	0x0000_0000
ADCMR1	ADC_BA+0x2C	R/W	A/D Compare Register 1	0x0000_0000

31	30	29	28	27	26	25	24
Reserved				CMPD[11:8]			
23	22	21	20	19	18	17	16
CMPD[7:0]							
15	14	13	12	11	10	9	8
Reserved				CMPMATCNT			
7	6	5	4	3	2	1	0
Reserved		CMPCH			CMPCOND	CMPIE	CMPEN

Bits	Description	
[31:28]	Reserved	Reserved
[27:16]	CMPD	<p>Comparison Data</p> <p>The 12-bit data is used to compare with conversion result of specified channel.</p> <p>When DMOF bit is set to 0, ADC comparator compares CMPD with conversion result with unsigned format. CMPD should be filled in unsigned format.</p> <p>When DMOF bit is set to 1, ADC comparator compares CMPD with conversion result with 2's complement format. CMPD should be filled in 2's complement format.</p>
[15:12]	Reserved	Reserved
[11:8]	CMPMATCNT	<p>Compare Match Count</p> <p>When the specified A/D channel analog conversion result matches the compare condition defined by CMPCOND[2], the internal match counter will increase 1. When the internal counter reaches the value to (CMPMATCNT +1), the CMPFx bit will be set.</p>
[7:6]	Reserved	Reserved
[5:3]	CMPCH	<p>Compare Channel Selection</p> <p>000 = Channel 0 conversion result is selected to be compared</p> <p>001 = Channel 1 conversion result is selected to be compared</p> <p>010 = Channel 2 conversion result is selected to be compared</p> <p>011 = Channel 3 conversion result is selected to be compared</p> <p>100 = Channel 4 conversion result is selected to be compared</p> <p>101 = Channel 5 conversion result is selected to be compared</p> <p>110 = Channel 6 conversion result is selected to be compared</p> <p>111 = Channel 7 conversion result is selected to be compared</p>



[2]	CMPCOND	<p>Compare Condition</p> <p>1 = Set the compare condition as that when a 12-bit A/D conversion result is greater or equal to the 12-bit CMPD (ADCMPRx[27:16]), the internal match counter will increase one.</p> <p>0 = Set the compare condition as that when a 12-bit A/D conversion result is less than the 12-bit CMPD (ADCMPRx[27:16]), the internal match counter will increase one.</p> <p>Note: When the internal counter reaches the value to (CMPMATCNT +1), the CMPF_x bit will be set.</p>
[1]	CMPIE	<p>Compare Interrupt Enable</p> <p>1 = Compare function interrupt Enabled.</p> <p>0 = Compare function interrupt Disabled.</p> <p>If the compare function is enabled and the compare condition matches the setting of CMPCOND and CMPMATCNT, CMPF bit will be asserted, in the meanwhile, if CMPIE is set to 1, a compare interrupt request is generated.</p>
[0]	CMPEN	<p>Compare Enable</p> <p>1 = Compare function Enabled.</p> <p>0 = Compare function Disabled.</p> <p>Set this bit to 1 to enable ADC controller to compare CMPD[11:0] with specified channel conversion result when converted data is loaded into ADDR register.</p>



A/D Status Register (ADSR)

Register	Offset	R/W	Description	Reset Value
ADSR	ADC_BA+0x30	R/W	A/D Status Register	0x0000_0000

31	30	29	28	27	26	25	24
Reserved							
23	22	21	20	19	18	17	16
OVERRUN							
15	14	13	12	11	10	9	8
VALID							
7	6	5	4	3	2	1	0
Reserved	CHANNEL			BUSY	CMPF1	CMPF0	ADF

Bits	Description	
[31:24]	Reserved	Reserved
[23:16]	OVERRUN	<p>Over Run Flag</p> <p>It is a mirror to OVERRUN bit in ADDR_x</p> <p>It is read only.</p>
[15:8]	VALID	<p>Data Valid flag</p> <p>It is a mirror of VALID bit in ADDR_x</p> <p>It is read only.</p>
[7]	Reserved	Reserved
[6:4]	CHANNEL	<p>Current Conversion Channel</p> <p>This field reflects current conversion channel when BUSY=1. When BUSY=0, it shows number of the next converted channel.</p> <p>It is read only.</p>
[3]	BUSY	<p>BUSY/IDLE</p> <p>1 = A/D converter is busy at conversion.</p> <p>0 = A/D converter is in idle state.</p> <p>This bit is mirror of as ADST bit in ADCR.</p> <p>It is read only.</p>
[2]	CMPF1	<p>Compare Flag</p> <p>When the selected channel A/D conversion result meets setting condition in ADCMPR1, this bit is set to 1. It is cleared by writing 1 to itself.</p> <p>1 = Conversion result in ADDR meets ADCMPR1 setting</p> <p>0 = Conversion result in ADDR does not meet ADCMPR1 setting</p>



[1]	CMPF0	<p>Compare Flag</p> <p>When the selected channel A/D conversion result meets setting condition in ADCMPR0, this bit is set to 1. It is cleared by writing 1 to itself.</p> <p>1 = Conversion result in ADDR meets ADCMPR0 setting 0 = Conversion result in ADDR does not meet ADCMPR0 setting</p>
[0]	ADF	<p>A/D Conversion End Flag</p> <p>A status flag that indicates the end of A/D conversion.</p> <p>ADF is set to 1 at these two conditions:</p> <ol style="list-style-type: none"> 1. When A/D conversion ends in single mode 2. When A/D conversion ends on all specified channels in scan mode <p>This flag can be cleared by writing 1 to self.</p>



A/D Calibration Register (ADCALR)

Register	Offset	R/W	Description	Reset Value
ADCALR	ADC_BA+0x34	R/W	A/D Calibration Register	0x0000_0000

31	30	29	28	27	26	25	24
Reserved							
23	22	21	20	19	18	17	16
Reserved							
15	14	13	12	11	10	9	8
Reserved							
7	6	5	4	3	2	1	0
Reserved						CALDONE	CALEN

Bits	Description	
[31:2]	Reserved	Reserved
[1]	CALDONE	<p>Calibration Complete</p> <p>1 = A/D converter self-calibration is finished.</p> <p>0 = A/D converter has not been calibrated or calibration is in progress if the CALEN bit is set.</p> <p>When writing 0 to the CALEN bit, CALDONE bit is cleared by hardware immediately. This bit is read only.</p>
[0]	CALEN	<p>Self-calibration Enable</p> <p>1 = Self-calibration Enabled</p> <p>0 = Self-calibration Disabled</p> <p>Software can set this bit to 1 to enable A/D converter to do self-calibration function. It needs 127 ADC clocks to complete calibration. This bit must be kept at 1 after CALDONE asserted. Clearing this bit will disable self-calibration function.</p>



A/D PDMA current transfer data Register (ADPDMA)

Register	Offset	R/W	Description	Reset Value
ADPDMA	ADC_BA+0x40	R	ADC PDMA current transfer data Register	0x0000_0000

31	30	29	28	27	26	25	24
Reserved							
23	22	21	20	19	18	17	16
Reserved							
15	14	13	12	11	10	9	8
Reserved				AD_PDMA[11:8]			
7	6	5	4	3	2	1	0
AD_PDMA[7:0]							

Bits	Description
[31:12]	Reserved
[11:0]	<p>AD_PDMA</p> <p>ADC PDMA Current Transfer Data Register</p> <p>When PDMA is transferring, reading this register can monitor the current PDMA transfer data. This bit is read only.</p>

5.17 Analog Comparator (CMP)

5.17.1 Overview

The NuMicro™ NUC100 Series contains two comparators, which can be used in a number of different configurations. The comparator output is a logical one when positive input greater than negative input, otherwise the output is a zero. Each comparator can be configured to cause an interrupt when the comparator output value changes. The block diagram is shown in Figure 5-108.

5.17.2 Features

- Analog input voltage range: 0~5.0 V
- Hysteresis function supported
- Two analog comparators with optional internal reference voltage input at negative end
- One interrupt vector for both comparators

5.17.3 Block Diagram

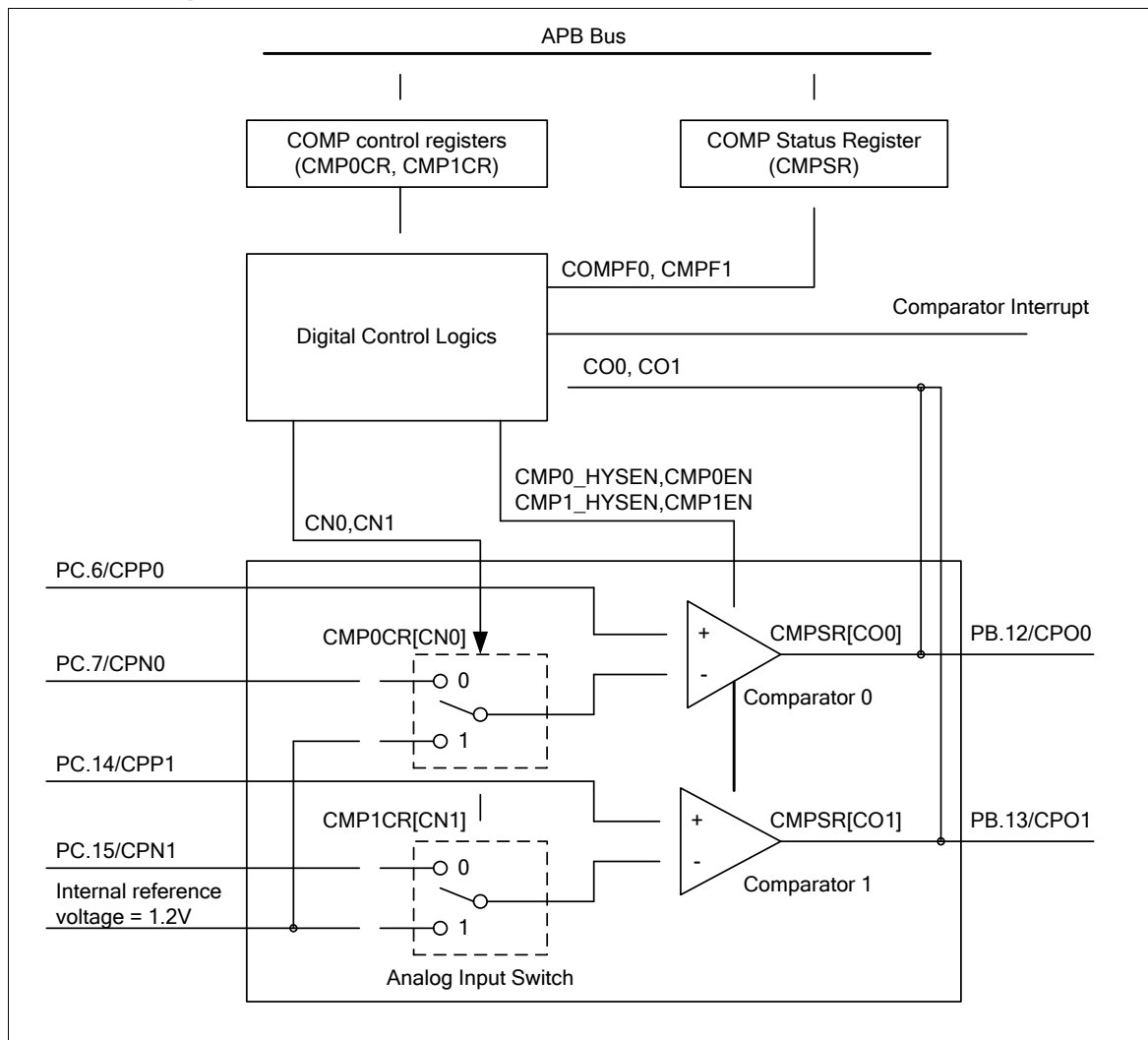

Figure 5-108 Analog Comparator Block Diagram

5.17.4 Functional Description

5.17.4.1 Interrupt Sources

The output of comparators are sampled by PCLK and reflected at CO1 and CO2 of CMPSR register. If CMP0IE/CMP1IE of CMP0CR/CMP1CR is set to 1, the comparator interrupt will be enabled. As the output state of comparator is changed, the comparator interrupt will be asserted and the corresponding flag, CMPF0 or CMPF1, will be set. Software can clear the flag to 0 by writing 1 to it.

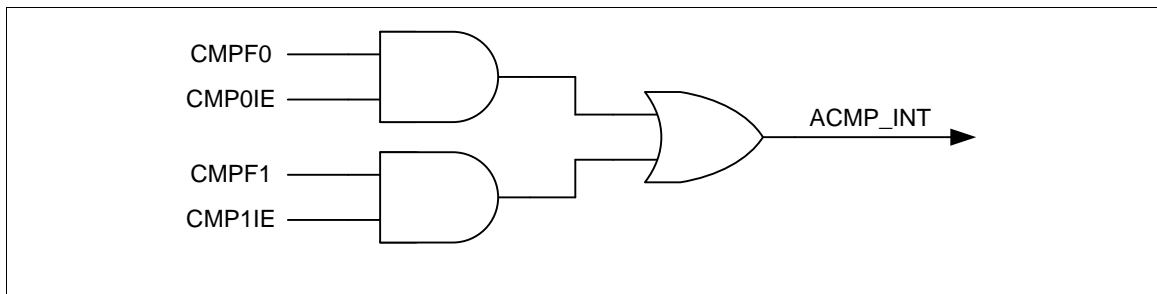

Figure 5-109 Comparator Controller Interrupt Sources



5.17.5 Register Map

R: read only, W: write only, R/W: both read and write

Register	Offset	R/W	Description	Reset Value
CMP Base Address:				
CMP_BA = 0x400D_0000				
CMP0CR	CMP_BA+0x00	R/W	Comparator0 Control Register	0x0000_0000
CMP1CR	CMP_BA+0x04	R/W	Comparator1 Control Register	0x0000_0000
CMPSR	CMP_BA+0x08	R/W	Comparator Status Register	0x0000_0000



5.17.6 Register Description

CMP0 Control Register (CMP0CR)

Register	Offset	R/W	Description	Reset Value
CMP0CR	CMP_BA+0x00	R/W	Comparator0 Control Register	0x0000_0000

31	30	29	28	27	26	25	24
Reserved							
23	22	21	20	19	18	17	16
Reserved							
15	14	13	12	11	10	9	8
Reserved							
7	6	5	4	3	2	1	0
Reserved			CMP0CN	Reserved	CMP0_HYSEN	CMP0IE	CMP0EN

Bits	Description	
[31:5]	Reserved	Reserved
[4]	CMP0CN	Comparator0 Negative Input Selection 1 = The internal band-gap reference voltage is selected as the source of negative comparator input 0 = The source of the negative comparator input is from CPN0 pin
[3]	Reserved	Reserved
[2]	CMP0_HYSEN	Comparator0 Hysteresis Enable 1 = Hysteresis function Enabled. The typical range is 20 mV. 0 = Hysteresis function Disabled (Default).
[1]	CMP0IE	Comparator0 Interrupt Enable 1 = Interrupt function Enabled. 0 = Interrupt function Disabled.
[0]	CMP0EN	Comparator0 Enable 1 = Enabled 0 = Disabled Comparator output needs wait 2 us stable time after CMP0EN is set.



CMP1 Control Register (CMP1CR)

Register	Offset	R/W	Description	Reset Value
CMP1CR	CMP_BA+0x04	R/W	Comparator1 Control Register	0x0000_0000

31	30	29	28	27	26	25	24
Reserved							
23	22	21	20	19	18	17	16
Reserved							
15	14	13	12	11	10	9	8
Reserved							
7	6	5	4	3	2	1	0
Reserved			CMP1CN	Reserved	CMP1_HYSE N	CMP1IE	CMP1EN

Bits	Description	
[31:5]	Reserved	Reserved
[4]	CMP1CN	Comparator1 Negative Input Selection 1 = The internal band-gap reference voltage is selected as the source of negative comparator input 0 = The source of the negative comparator input is from CPN1 pin
[3]	Reserved	Reserved
[2]	CMP1_HYSEN	Comparator1 Hysteresis Enable 1 = Hysteresis function Enabled. The typical range is 20 mV. 0 = Hysteresis function Disabled (Default).
[1]	CMP1IE	Comparator1 Interrupt Enable 1 = Interrupt function Enabled. 0 = Interrupt function Disabled.
[0]	CMP1EN	Comparator1 Enable 1 = Enabled. 0 = Disabled. Comparator output needs to wait 2 us stable time after CMP1EN is set.



CMP Status Register (CMPSR)

Register	Offset	R/W	Description	Reset Value
CMPSR	CMP_BA+0x08	R/W	Comparator Status Register	0x0000_0000

31	30	29	28	27	26	25	24
Reserved							
23	22	21	20	19	18	17	16
Reserved							
15	14	13	12	11	10	9	8
Reserved							
7	6	5	4	3	2	1	0
Reserved				CO1	CO0	CMPF1	CMPF0

Bits	Description	
[31:4]	Reserved	Reserved
[3]	CO1	Comparator1 Output Synchronized to the APB clock to allow reading by software. Cleared when the comparator is disabled (CMP1EN = 0).
[2]	CO0	Comparator0 Output Synchronized to the APB clock to allow reading by software. Cleared when the comparator is disabled (CMP0EN = 0).
[1]	CMPF1	Comparator1 Flag This bit is set by hardware whenever the comparator1 output changes state. This will cause an interrupt if CMP1IE set. Write 1 to clear this bit to 0.
[0]	CMPF0	Comparator0 Flag This bit is set by hardware whenever the comparator0 output changes state. This will cause an interrupt if CMP0IE set. Write 1 to clear this bit to 0.



5.18 PDMA Controller (PDMA)

5.18.1 Overview

The NuMicro™ NUC130/NUC140 contains a peripheral direct memory access (PDMA) controller that transfers data to and from memory or transfer data to and from APB devices. The PDMA has nine channels of DMA (Peripheral-to-Memory or Memory-to-Peripheral or Memory-to-Memory). For each PDMA channel (PDMA CH0~CH8), there is one word buffer as transfer buffer between the Peripherals APB devices and Memory.

Software can stop the PDMA operation by disable PDMA [PDMACEN]. The CPU can recognize the completion of a PDMA operation by software polling or when it receives an internal PDMA interrupt. The PDMA controller can increase source or destination address or fixed them as well.

Note: The partial of NuMicro™ NUC130/NUC140 only has 1 PDMA channel (channel 0).

5.18.2 Features

- Supports nine DMA channels. Each channel can support a unidirectional transfer
- AMBA AHB master/slave interface compatible, for data transfer and register read/write
- Supports source and destination address increased mode or fixed mode
- Hardware channel priority – DMA channel 0 has the highest priority and channel 8 has the lowest priority



5.18.3 Block Diagram

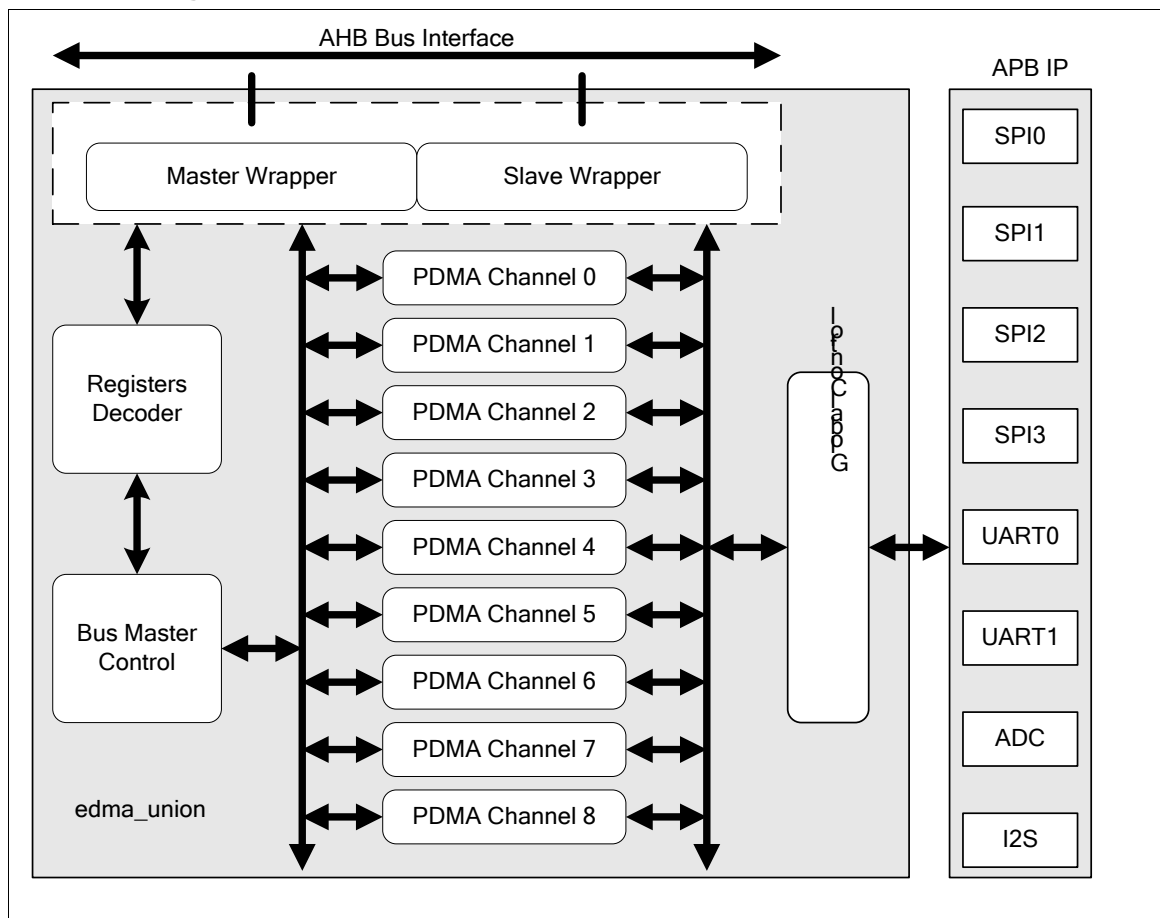

Figure 5-110 PDMA Controller Block Diagram



5.18.4 Functional Description

The PDMA controller has nine channels of DMA associated with Peripheral-to-Memory · Memory-to-Peripheral or Memory-to-Memory. For each PDMA channel, there is one word memory as transfer buffer between the Peripherals APB IP and Memory.

The CPU can recognize the completion of a PDMA operation by software polling or when it receives an internal PDMA interrupt. As to the source and destination address, the PDMA controller has two modes: increased and fixed.

Every PDMA default channel behavior is not pre-defined, so users must configure the channel service settings of PDMA_PDSSR0, PDMA_PDSSR1 and PDMA_PDSSR2 before start the related PDMA channel.

Software must enable DMA channel PDMA [PDMACEN] and then write a valid source address to the PDMA_SARx register, a destination address to the PDMA_DARx register, and a transfer count to the PDMA_BCRx register. Next, trigger the DMA_CSRx PDMA [TRIG_EN]. PDMA will continue the transfer until PDMA_CBCRx comes down to zero, If an error occurs during the PDMA operation, the channel stops unless software clears the error condition and sets the PDMA_CSRx [SW_RST] to reset the PDMA channel and set PDMA_CSRx [PDMACEN] and [TRIG_EN] bits field to start again.

In PDMA (Peripheral-to-Memory or Memory-to-Peripheral) mode, DMA can transfer data between the Peripherals APB IP (ex: UART, SPI, ADC....) and Memory.



5.18.5 Register Map

R: read only, W: write only, R/W: both read and write

Register	Offset	R/W	Description	Reset Value
PDMA Base Address: PDMA_BA_chn = 0x5000_8000 + (0x0100*n) n=0,1..8 PDMA_BA_GCR = 0x5000_8F00				
PDMA_CSR n=0,1..8	PDMA_BA_chn+0x00	R/W	PDMA Control and Status Register	0x0000_0000
PDMA_SAR n=0,1..8	PDMA_BA_chn+0x04	R/W	PDMA Transfer Source Address Register	0x0000_0000
PDMA_DAR n=0,1..8	PDMA_BA_chn+0x08	R/W	PDMA Transfer Destination Address Register	0x0000_0000
PDMA_BCR n=0,1..8	PDMA_BA_chn+0x0C	R/W	PDMA Transfer Byte Count Register	0x0000_0000
PDMA_POINT n=0,1..8	PDMA_BA_chn+0x10	R	PDMA Internal Buffer Pointer Register	0xFFFF_0000
PDMA_CSAR n=0,1..8	PDMA_BA_chn+0x14	R	PDMA Current Source Address Register	0x0000_0000
PDMA_CDAR n=0,1..8	PDMA_BA_chn+0x18	R	PDMA Current Destination Address Register	0x0000_0000
PDMA_CBCR n=0,1..8	PDMA_BA_chn+0x1C	R	PDMA Current Transfer Byte Count Register	0x0000_0000
PDMA_IER n=0,1..8	PDMA_BA_chn+0x20	R/W	PDMA Interrupt Enable Control Register	0x0000_0001
PDMA_ISR n=0,1..8	PDMA_BA_chn+0x24	R/W	PDMA Interrupt Status Register	0x0000_0000
PDMA_SBUF0_c n=0,1..8	PDMA_BA_chn+0x80	R	PDMA Shared Buffer FIFO 0 Register	0x0000_0000
PDMA_GCRCSR	PDMA_BA_GCR+0x00	R/W	PDMA Global Control Register	0x0000_0000
PDMA_PDSSR0	PDMA_BA_GCR+0x04	R/W	PDMA Service Selection Control Register 0	0xFFFF_FFFF
PDMA_PDSSR1	PDMA_BA_GCR+0x08	R/W	PDMA Service Selection Control Register 1	0xFFFF_FFFF
PDMA_GCRISR	PDMA_BA_GCR+0x0C	R/W	PDMA Global Interrupt Status Register	0x0000_0000
PDMA_PDSSR2	PDMA_BA_GCR+0x10	R/W	PDMA Service Selection Control Register 2	0x0000_00FF



5.18.6 Register Description

PDMA Control and Status Register (PDMA_CSRx)

Register	Offset	R/W	Description	Reset Value
PDMA_CSR n=0,1..8	PDMA_BA_chn+0x00	R/W	PDMA Control and Status Register	0x0000_0000

31	30	29	28	27	26	25	24
Reserved							
23	22	21	20	19	18	17	16
TRIG_EN	Reserved		APB_TWS		Reserved		
15	14	13	12	11	10	9	8
Reserved							
7	6	5	4	3	2	1	0
DAD_SEL		SAD_SEL		MODE_SEL		SW_RST	PDMACEN

Bits	Description	
[31:24]	Reserved	Reserved
[23]	TRIG_EN	<p>Trigger Enable</p> <p>1 = PDMA data read or write transfer Enabled.</p> <p>0 = No effect.</p> <p>Note: When PDMA transfer completed, this bit will be cleared automatically.</p> <p>If the bus error occurs, all PDMA transfer will be stopped. Software must reset all PDMA channel, and then trigger again.</p>
[22:21]	Reserved	Reserved
[20:19]	APB_TWS	<p>Peripheral transfer Width Selection</p> <p>00 = One word (32-bit) is transferred for every PDMA operation.</p> <p>01 = One byte (8-bit) is transferred for every PDMA operation.</p> <p>10 = One half-word (16-bit) is transferred for every PDMA operation.</p> <p>11 = Reserved.</p> <p>Note: This field is meaningful only when MODE_SEL is Peripheral to Memory mode (Peripheral-to-Memory) or Memory to Peripheral mode (Memory-to-Peripheral).</p>
[18:8]	Reserved	Reserved



[7:6]	DAD_SEL	Transfer Destination Address Direction Selection 00 = Transfer Destination address is increasing successively. 01 = Reserved. 10 = Transfer Destination address is fixed (This feature can be used when data where transferred from multiple sources to a single destination). 11 = Reserved.
[5:4]	SAD_SEL	Transfer Source Address Direction Selection 00 = Transfer Source address is increasing successively. 01 = Reserved. 10 = Transfer Source address is fixed (This feature can be used when data where transferred from a single source to multiple destinations). 11 = Reserved.
[3:2]	MODE_SEL	PDMA Mode Selection 00 = Memory to Memory mode (Memory-to-Memory). 01 = Peripheral to Memory mode (Peripheral-to-Memory). 10 = Memory to Peripheral mode (Memory-to-Peripheral).
[1]	SW_RST	Software Engine Reset 0 = Writing 0 to this bit has no effect. 1 = Writing 1 to this bit will reset the internal state machine, pointers and internal buffer. The contents of control register will not be cleared. This bit will auto clear after few clock cycles.
[0]	PDMACEN	PDMA Channel Enable Setting this bit to 1 enables PDMA's operation. If this bit is cleared, PDMA will ignore all PDMA request and force Bus Master into IDLE state. Note: SW_RST(PDMA_CSRx[1], x= 0~8) will clear this bit



PDMA Transfer Source Address Register (PDMA_SARx)

Register	Offset	R/W	Description	Reset Value
PDMA_SAR n=0,1..8	PDMA_BA_chn+0x04	R/W	PDMA Transfer Source Address Register	0x0000_0000

31	30	29	28	27	26	25	24
PDMA_SAR [31:24]							
23	22	21	20	19	18	17	16
PDMA_SAR [23:16]							
15	14	13	12	11	10	9	8
PDMA_SAR [15:8]							
7	6	5	4	3	2	1	0
PDMA_SAR [7:0]							

Bits	Description	
[31:0]	PDMA_SAR	<p>PDMA Transfer Source Address Register</p> <p>This field indicates a 32-bit source address of PDMA.</p> <p>Note: The source address must be word alignment</p>



PDMA Transfer Destination Address Register (PDMA_DARx)

Register	Offset	R/W	Description	Reset Value
PDMA_DAR n=0,1..8	PDMA_BA_chn+0x08	R/W	PDMA Transfer Destination Address Register	0x0000_0000

31	30	29	28	27	26	25	24
PDMA_DAR [31:24]							
23	22	21	20	19	18	17	16
PDMA_DAR [23:16]							
15	14	13	12	11	10	9	8
PDMA_DAR [15:8]							
7	6	5	4	3	2	1	0
PDMA_DAR [7:0]							

Bits	Description
[31:0]	<p>PDMA_DAR</p> <p>PDMA Transfer Destination Address Register</p> <p>This field indicates a 32-bit destination address of PDMA.</p> <p>Note: The destination address must be word alignment</p>



PDMA Transfer Byte Count Register (PDMA_BCRx)

Register	Offset	R/W	Description	Reset Value
PDMA_BCR n=0,1..8	PDMA_BA_chn+0x0C	R/W	PDMA Transfer Byte Count Register	0x0000_0000

31	30	29	28	27	26	25	24
Reserved							
23	22	21	20	19	18	17	16
Reserved							
15	14	13	12	11	10	9	8
PDMA_BCR [15:8]							
7	6	5	4	3	2	1	0
PDMA_BCR [7:0]							

Bits	Description	
[31:16]	Reserved	Reserved
[15:0]	PDMA_BCR	PDMA Transfer Byte Count Register This field indicates a 16-bit transfer byte count number of PDMA, it must be word alignment.



PDMA Internal Buffer Pointer Register (PDMA_POINTx)

Register	Offset	R/W	Description	Reset Value
PDMA_POINT n=0,1..8	PDMA_BA_chn+0x10	R	PDMA Internal Buffer Pointer Register	0xFFFF_0000

31	30	29	28	27	26	25	24
Reserved							
23	22	21	20	19	18	17	16
Reserved							
15	14	13	12	11	10	9	8
Reserved							
7	6	5	4	3	2	1	0
Reserved				PDMA_POINT			

Bits	Description	
[31:2]	Reserved	Reserved
[1:0]	PDMA_POINT	PDMA Internal Buffer Pointer Register (Read Only) This field indicates the internal buffer pointer.



PDMA Current Source Address Register (PDMA_CSARx)

Register	Offset	R/W	Description	Reset Value
PDMA_CSAR n=0,1..8	PDMA_BA_chn+0x14	R	PDMA Current Source Address Register	0x0000_0000

31	30	29	28	27	26	25	24
PDMA_CSAR [31:24]							
23	22	21	20	19	18	17	16
PDMA_CSAR [23:16]							
15	14	13	12	11	10	9	8
PDMA_CSAR [15:8]							
7	6	5	4	3	2	1	0
PDMA_CSAR [7:0]							

Bits	Description	
[31:0]	PDMA_CSAR	PDMA Current Source Address Register (Read Only) This field indicates the source address where the PDMA transfer is just occurring.



PDMA Current Destination Address Register (PDMA_CDARx)

Register	Offset	R/W	Description	Reset Value
PDMA_CDAR n=0,1..8	PDMA_BA_chn+0x18	R	PDMA Current Destination Address Register	0x0000_0000

31	30	29	28	27	26	25	24
PDMA_CDAR [31:24]							
23	22	21	20	19	18	17	16
PDMA_CDAR [23:16]							
15	14	13	12	11	10	9	8
PDMA_CDAR [15:8]							
7	6	5	4	3	2	1	0
PDMA_CDAR [7:0]							

Bits	Description	
[31:0]	PDMA_CDAR	PDMA Current Destination Address Register (Read Only) This field indicates the destination address where the PDMA transfer is just occurring.



PDMA Current Byte Count Register (PDMA_CBCRx)

Register	Offset	R/W	Description	Reset Value
PDMA_CBCR N=0,1..8	PDMA_BA_chn+0x1C	R	PDMA Current Transfer Byte Count Register	0x0000_0000

31	30	29	28	27	26	25	24
Reserved							
23	22	21	20	19	18	17	16
Reserved							
15	14	13	12	11	10	9	8
PDMA_CBCR [15:8]							
7	6	5	4	3	2	1	0
PDMA_CBCR [7:0]							

Bits	Description	
[31:16]	Reserved	Reserved
[15:0]	PDMA_CBCR	PDMA Current Byte Count Register (Read Only) This field indicates the current remained byte count of PDMA. Note: SW_RST will clear this register value.



PDMA Interrupt Enable Control Register (PDMA_IERx)

Register	Offset	R/W	Description	Reset Value
PDMA_IER N=0,1..8	PDMA_BA_chn+0x20	R/W	PDMA Interrupt Enable Control Register	0x0000_0001

31	30	29	28	27	26	25	24
Reserved							
23	22	21	20	19	18	17	16
Reserved							
15	14	13	12	11	10	9	8
Reserved							
7	6	5	4	3	2	1	0
Reserved						BLKD_IE	TABORT_IE

Bits	Description	
[31:2]	Reserved	Reserved
[1]	BLKD_IE	PDMA Transfer Done Interrupt Enable 1 = Enabled interrupt generator when PDMA transfer is done. 0 = Disabled interrupt generator when PDMA transfer is done.
[0]	TABORT_IE	PDMA Read/Write Target Abort Interrupt Enable 1 = Enabled target abort interrupt generation during PDMA transfer. 0 = Disabled target abort interrupt generation during PDMA transfer.



PDMA Interrupt Status Register (PDMA_ISRx)

Register	Offset	R/W	Description	Reset Value
PDMA_ISR n=0,1..8	PDMA_BA_chn+0x24	R/W	PDMA Interrupt Status Register	0x0000_0000

31	30	29	28	27	26	25	24
Reserved							
23	22	21	20	19	18	17	16
Reserved							
15	14	13	12	11	10	9	8
Reserved							
7	6	5	4	3	2	1	0
Reserved						BLKD_IF	TABORT_IF

Bits	Description	
[31:2]	Reserved	Reserved
[1]	BLKD_IF	<p>Block Transfer Done Interrupt Flag</p> <p>This bit indicates that PDMA has finished all transfer.</p> <p>1 = Done</p> <p>0 = Not finished yet</p> <p>Software can write 1 to clear this bit to 0</p>
[0]	TABORT_IF	<p>PDMA Read/Write Target Abort Interrupt Flag</p> <p>1 = Bus ERROR response received</p> <p>0 = No bus ERROR response received</p> <p>Software can write 1 to clear this bit to 0</p>

Note: The PDMA_ISR [TABORT_IF] indicate bus master received ERROR response or not. If bus master received ERROR response, it means that target abort is happened. PDMAc will stop transfer and respond this event to software then go to IDLE state. When target abort occurred, software must reset PDMA, and then transfer those data again.

PDMA Shared Buffer FIFO 0 (PDMA_SBUF0_cx)

Register	Offset	R/W	Description	Reset Value
PDMA_SBUF0_c n=0,1..8	PDMA_BA_chn+0x80	R	PDMA Shared Buffer FIFO 0 Register	0x0000_0000

31	30	29	28	27	26	25	24
PDMA_SBUF0 [31:24]							
23	22	21	20	19	18	17	16



PDMA_SBUF0 [23:16]							
15	14	13	12	11	10	9	8
PDMA_SBUF0 [15:8]							
7	6	5	4	3	2	1	0
PDMA_SBUF0 [7:0]							

Bits	Description	
[31:0]	PDMA_SBUF0	PDMA Shared Buffer FIFO 0 (Read Only) Each channel has its own 1 words internal buffer.



PDMA Global Control Register (PDMA_GCRCSR)

Register	Offset	R/W	Description	Reset Value
PDMA_GCRCSR	PDMA_BA_GCR+0x00	R/W	PDMA Global Control Register	0x0000_0000

31	30	29	28	27	26	25	24
Reserved							
23	22	21	20	19	18	17	16
Reserved							CLK8_EN
15	14	13	12	11	10	9	8
CLK7_EN	CLK6_EN	CLK5_EN	CLK4_EN	CLK3_EN	CLK2_EN	CLK1_EN	CLK0_EN
7	6	5	4	3	2	1	0
Reserved							

Bits	Description	
[31:17]	Reserved	Reserved
[16]	CLK8_EN	PDMA Controller Channel 8 Clock Enable Control 0 = Disabled 1 = Enabled
[15]	CLK7_EN	PDMA Controller Channel 7 Clock Enable Control 0 = Disabled 1 = Enabled
[14]	CLK6_EN	PDMA Controller Channel 6 Clock Enable Control 0 = Disabled 1 = Enabled
[13]	CLK5_EN	PDMA Controller Channel 5 Clock Enable Control 0 = Disabled 1 = Enabled
[12]	CLK4_EN	PDMA Controller Channel 4 Clock Enable Control 0 = Disabled 1 = Enabled
[11]	CLK3_EN	PDMA Controller Channel 3 Clock Enable Control 0 = Disabled 1 = Enabled
[10]	CLK2_EN	PDMA Controller Channel 2 Clock Enable Control 0 = Disabled 1 = Enabled



[9]	CLK1_EN	PDMA Controller Channel 1 Clock Enable Control 0 = Disabled 1 = Enabled
[8]	CLK0_EN	PDMA Controller Channel 0 Clock Enable Control 0 = Disabled 1 = Enabled
[7:0]	Reserved	Reserved



PDMA Service Selection Control Register 0 (PDMA_PDSSR0)

Register	Offset	R/W	Description	Reset Value
PDMA_PDSSR0	PDMA_BA_GCR+0x04	R/W	PDMA Service Selection Control Register 0	0xFFFF_FFFF

31	30	29	28	27	26	25	24
SPI3_TXSEL				SPI3_RXSEL			
23	22	21	20	19	18	17	16
SPI2_TXSEL				SPI2_RXSEL			
15	14	13	12	11	10	9	8
SPI1_TXSEL				SPI1_RXSEL			
7	6	5	4	3	2	1	0
SPI0_TXSEL				SPI0_RXSEL			

Bits	Description	
[31:28]	SPI3_TXSEL	PDMA SPI3 TX Selection This field defines which PDMA channel is connected to the on-chip peripheral SPI3 TX. Software can configure the TX channel setting by SPI3_TXSEL. The channel configuration is the same as SPI0_RXSEL field. Please refer to the explanation of SPI0_RXSEL.
[27:24]	SPI3_RXSEL	PDMA SPI3 RX Selection This field defines which PDMA channel is connected to the on-chip peripheral SPI3 RX. Software can configure the RX channel setting by SPI3_RXSEL. The channel configuration is the same as SPI0_RXSEL field. Please refer to the explanation of SPI0_RXSEL.
[23:20]	SPI2_TXSEL	PDMA SPI2 TX Selection This field defines which PDMA channel is connected to the on-chip peripheral SPI2 TX. Software can configure the TX channel setting by SPI2_TXSEL. The channel configuration is the same as SPI0_RXSEL field. Please refer to the explanation of SPI0_RXSEL.
[19:16]	SPI2_RXSEL	PDMA SPI2 RX Selection This field defines which PDMA channel is connected to the on-chip peripheral SPI2 RX. Software can configure the RX channel setting by SPI2_RXSEL. The channel configuration is the same as SPI0_RXSEL field. Please refer to the explanation of SPI0_RXSEL.
[15:12]	SPI1_TXSEL	PDMA SPI1 TX Selection This field defines which PDMA channel is connected to the on-chip peripheral SPI1 TX. Software can configure the TX channel setting by SPI1_TXSEL. The channel configuration is the same as SPI0_RXSEL field. Please refer to the explanation of SPI0_RXSEL.
[11:8]	SPI1_RXSEL	PDMA SPI1 RX Selection This field defines which PDMA channel is connected to the on-chip peripheral SPI1 RX. Software can configure the RX channel setting by SPI1_RXSEL. The channel configuration is the same as SPI0_RXSEL field. Please refer to the explanation of SPI0_RXSEL.



[7:4]	SPI0_TXSEL	<p>PDMA SPI0 TX Selection</p> <p>This field defines which PDMA channel is connected to the on-chip peripheral SPI0 TX. Software can configure the TX channel setting by SPI0_TXSEL. The channel configuration is the same as SPI0_RXSEL field. Please refer to the explanation of SPI0_RXSEL.</p>
[3:0]	SPI0_RXSEL	<p>PDMA SPI0 RX Selection</p> <p>This field defines which PDMA channel is connected to the on-chip peripheral SPI0 RX. Software can change the channel RX setting by SPI0_RXSEL.</p> <p>4'b0000: CH0 4'b0001: CH1 4'b0010: CH2 4'b0011: CH3 4'b0100: CH4 4'b0101: CH5 4'b0110: CH6 4'b0111: CH7 4'b1000: CH8</p> <p>Others : Reserved</p> <p>Note: Ex : SPI0_RXSEL = 4'b0110, that means SPI0_RX is connected to PDMA_CH6</p>



PDMA Service Selection Control Register 1 (PDMA_PDSSR1)

Register	Offset	R/W	Description	Reset Value
PDMA_PDSSR1	PDMA_BA_GCR+0x08	R/W	PDMA Service Selection Control Register 1	0xFFFF_FFFF

31	30	29	28	27	26	25	24
Reserved				ADC_RXSEL			
23	22	21	20	19	18	17	16
Reserved							
15	14	13	12	11	10	9	8
UART1_TXSEL				UART1_RXSEL			
7	6	5	4	3	2	1	0
UART0_TXSEL				UART0_RXSEL			

Bits	Description	
[31:28]	Reserved	Reserved
[27:24]	ADC_RXSEL	PDMA ADC RX Selection This field defines which PDMA channel is connected to the on-chip peripheral ADC RX. Software can configure the RX channel setting by ADC_RXSEL. The channel configuration is the same as UART0_RXSEL field. Please refer to the explanation of UART0_RXSEL.
[23:16]	Reserved	Reserved
[15:12]	UART1_TXSEL	PDMA UART1 TX Selection This field defines which PDMA channel is connected to the on-chip peripheral UART1 TX. Software can configure the TX channel setting by UART1_TXSEL. The channel configuration is the same as UART0_RXSEL field. Please refer to the explanation of UART0_RXSEL.
[11:8]	UART1_RXSEL	PDMA UART1 RX Selection This field defines which PDMA channel is connected to the on-chip peripheral UART1 RX. Software can configure the RX channel setting by UART1_RXSEL. The channel configuration is the same as UART0_RXSEL field. Please refer to the explanation of UART0_RXSEL.
[7:4]	UART0_TXSEL	PDMA UART0 TX Selection This field defines which PDMA channel is connected to the on-chip peripheral UART0 TX. Software can configure the TX channel setting by UART0_TXSEL. The channel configuration is the same as UART0_RXSEL field. Please refer to the explanation of UART0_RXSEL.



[3:0]	UART0_RXSEL	<p>This field defines which PDMA channel is connected to the on-chip peripheral UART0 RX. Software can change the channel RX setting by UART0_RXSEL</p> <p>4'b0000: CH0 4'b0001: CH1 4'b0010: CH2 4'b0011: CH3 4'b0100: CH4 4'b0101: CH5 4'b0110: CH6 4'b0111: CH7 4'b1000: CH8 Others : Reserved</p> <p>Note: Ex : UART0_RXSEL = 4'b0110, that means UART0_RX is connected to PDMA_CH6</p>
-------	--------------------	---



PDMA Global Interrupt Status Register (PDMA_GCRISR)

Register	Offset	R/W	Description	Reset Value
PDMA_GCRISR	PDMA_BA_GCR+0x0C	R/W	PDMA Global Interrupt Status Register	0x0000_0000

31	30	29	28	27	26	25	24
INTR	Reserved						
23	22	21	20	19	18	17	16
Reserved							
15	14	13	12	11	10	9	8
Reserved							INTR8
7	6	5	4	3	2	1	0
INTR7	INTR6	INTR5	INTR4	INTR3	INTR2	INTR1	INTR0

Bits	Description	
[31]	INTR	Interrupt Pin Status This bit is the Interrupt status of PDMA controller. Note: This bit is read only
[30:9]	Reserved	Reserved
[8]	INTR8	Interrupt Pin Status of Channel 8 This bit is the Interrupt status of PDMA channel8. Note: This bit is read only
[7]	INTR7	Interrupt Pin Status of Channel 7 This bit is the Interrupt status of PDMA channel7. Note: This bit is read only
[6]	INTR6	Interrupt Pin Status of Channel 6 This bit is the Interrupt status of PDMA channel6. Note: This bit is read only
[5]	INTR5	Interrupt Pin Status of Channel 5 This bit is the Interrupt status of PDMA channel5. Note: This bit is read only
[4]	INTR4	Interrupt Pin Status of Channel 4 This bit is the Interrupt status of PDMA channel4. Note: This bit is read only
[3]	INTR3	Interrupt Pin Status of Channel 3 This bit is the Interrupt status of PDMA channel3. Note: This bit is read only



[2]	INTR2	Interrupt Pin Status of Channel 2 This bit is the Interrupt status of PDMA channel2. Note: This bit is read only
[1]	INTR1	Interrupt Pin Status of Channel 1 This bit is the Interrupt status of PDMA channel1. Note: This bit is read only
[0]	INTR0	Interrupt Pin Status of Channel 0 This bit is the Interrupt status of PDMA channel0. Note: This bit is read only



PDMA Service Selection Control Register 2 (PDMA_PDSSR2)

Register	Offset	R/W	Description	Reset Value
PDMA_PDSSR2	PDMA_BA_GCR+0x10	R/W	PDMA Service Selection Control Register 2	0x0000_00FF

31	30	29	28	27	26	25	24
Reserved							
23	22	21	20	19	18	17	16
Reserved							
15	14	13	12	11	10	9	8
Reserved							
7	6	5	4	3	2	1	0
I2S_TXSEL				I2S_RXSEL			

Bits	Description	
[31:8]	Reserved	Reserved
[7:4]	I2S_TXSEL	PDMA I²S TX Selection This field defines which PDMA channel is connected to the on-chip peripheral I ² S TX. Software can configure the TX channel setting by I2S_TXSEL. The channel configuration is the same as I2S_RXSEL field. Please refer to the explanation of I2S_RXSEL.
[3:0]	I2S_RXSEL	PDMA I²S RX Selection This field defines which PDMA channel is connected to the on-chip peripheral I ² S RX. Software can change the channel RX setting by I2S_RXSEL. 4'b0000: CH0 4'b0001: CH1 4'b0010: CH2 4'b0011: CH3 4'b0100: CH4 4'b0101: CH5 4'b0110: CH6 4'b0111: CH7 4'b1000: CH8 Others : Reserved Note: Ex : I2S_RXSEL = 4'b0110, that means I2S_RX is connected to PDMA_CH6

5.19 External Bus Interface (EBI)

5.19.1 Overview

The NuMicro™ NUC130/NUC140 LQFP-64 and LQFP-100 package has an external bus interface (EBI) for external device used.

To save the connections between external device and this chip, EBI support address bus and data bus multiplex mode. Also, address latch enable (ALE) signal supported differentiate the address and data cycle.

5.19.2 Features

External Bus Interface has the following functions:

- External devices with max. 64 Kbytes (8-bit data width)/128 Kbytes (16-bit data width) supported
- Variable external bus base clock (MCLK) supported
- 8-bit or 16-bit data width supported
- Variable data access time (tACC), address latch enable time (tALE) and address hold time (tAHD) supported
- Address bus and data bus multiplex mode supported to save the address pins
- Configurable idle cycle supported for different access condition: Write command finish (W2X), Read-to-Read (R2R)



5.19.3 Block Diagram

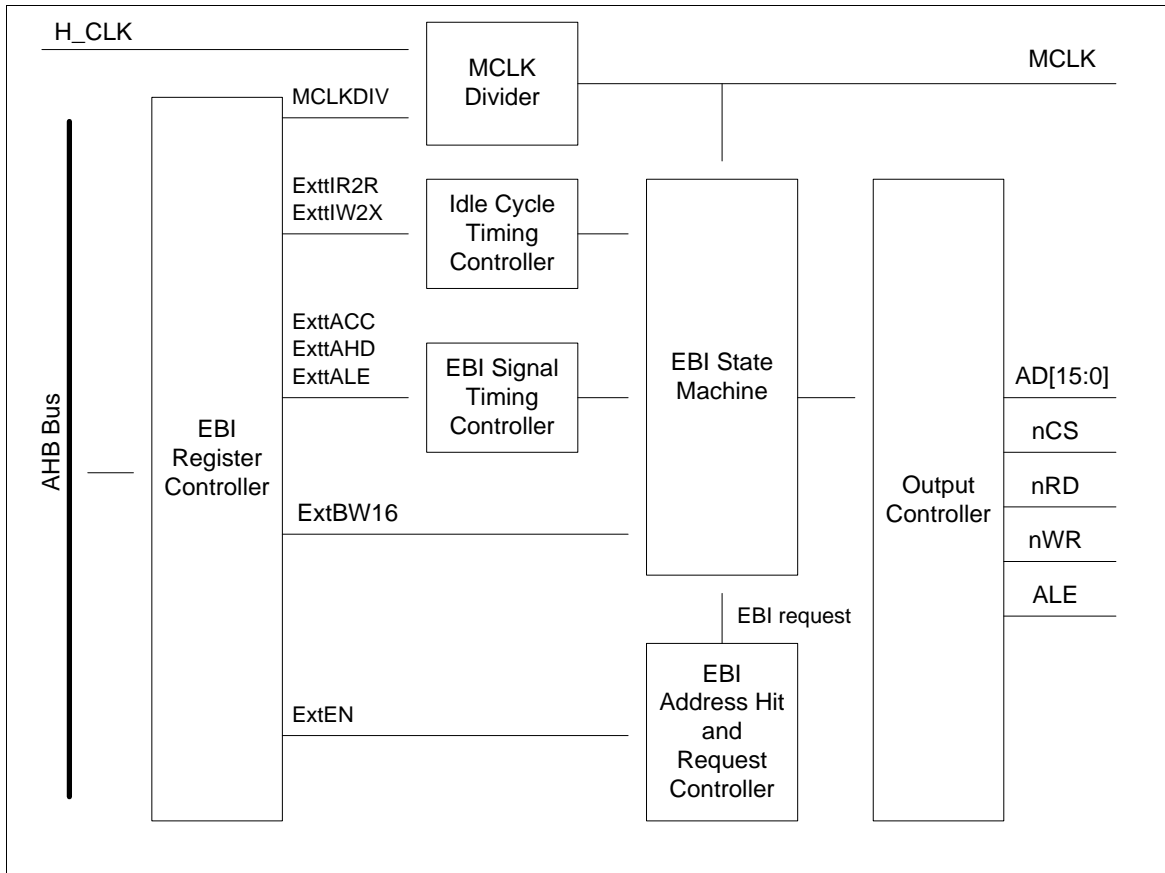

Figure 5-111 EBI Block Diagram

5.19.4 Functional Description

5.19.4.1 EBI Area and Address Hit

EBI mapping address is located at 0x6000_0000 ~ 0x6001_FFFF and the total memory space is 128Kbyte. When system request address hit EBI's memory space, the corresponding EBI chip select signal is assert and EBI state machine operates.

For an 8-bit device (64Kbyte), EBI mapped this 64Kbyte device to 0x6000_0000 ~ 0x6000_FFFF and 0x6001_0000 ~ 0x6001_FFFF simultaneously.

5.19.4.2 EBI Data Width Connection

EBI support device whose address bus and data bus are multiplexed. For the external device with separated address and data bus, the connection to device needs additional logic to latch the address. In this case, pin ALE is connected to the latch device to latch the address value. Pin AD is the input of the latch device, and the output of the latch device is connected to the address of external device. For 16-bit device, the AD [15:0] shared by address and 16-bit data. For 8-bit device, only AD [7:0] shared by address and 8-bit data, AD [15:8] is dedicated for address and could be connected to 8-bit device directly.

For 8-bit data width, chip system address bit [15:0] is used as the device's address [15:0]. For 16-

bit data width, chip system address bit [16:1] is used as the device's address [15:0] and chip system address bit [0] is useless.

EBI bit width	System address (AHBADR)	EBI address (AD)
8-bit	AHBADR[15:0]	AD[15:0]
16-bit	AHBADR[16:1]	AD[15:0]

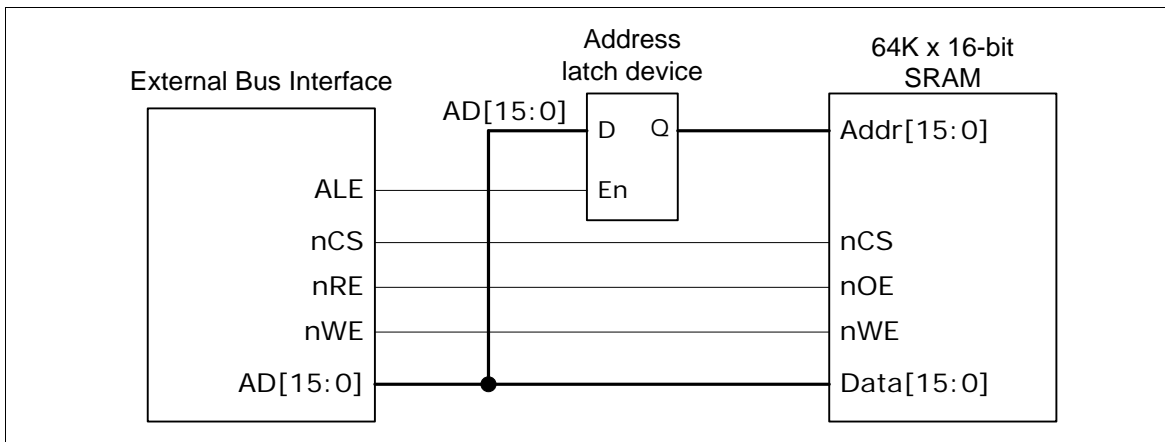

Figure 5-112 Connection of 16-bit EBI Data Width with 16-bit Device

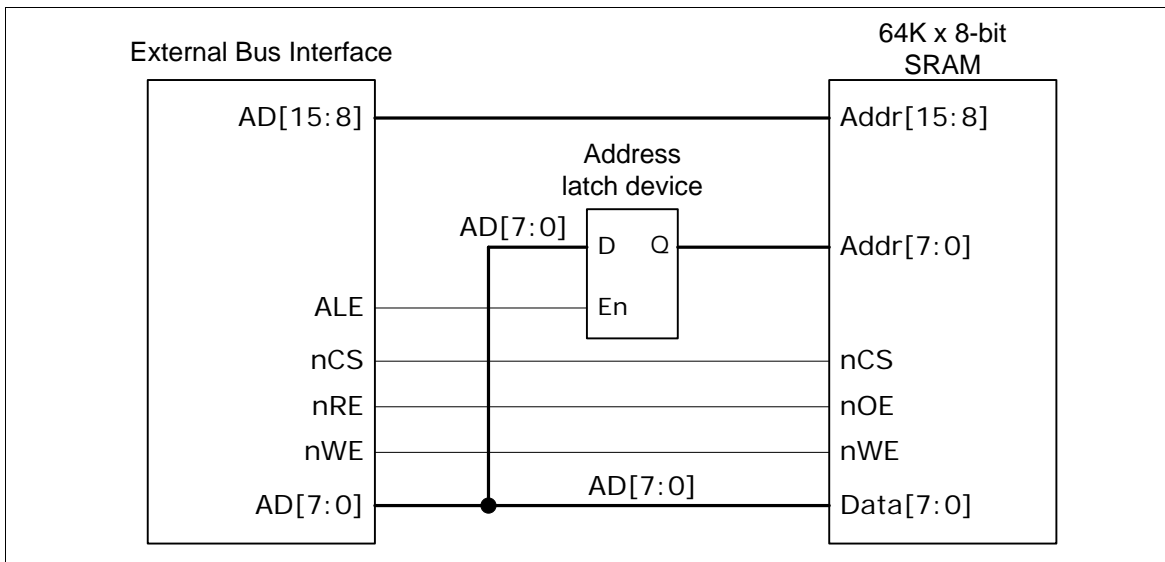

Figure 5-113 Connection of 8-bit EBI Data Width with 8-bit Device

When system access data width is larger than EBI data width, EBI controller will finish a system access command by operating EBI access more than once. For example, if system requests a 32-bit data through EBI device, EBI controller will operate accessing four times when setting EBI data width with 8-bit.



5.19.4.3 EBI Operating Control

MCLK Control

In the chip, all EBI signals will be synchronized by MCLK when EBI is operating. When chip connects to the external device with slower operating frequency, the MCLK can divide most to HCLK/32 by setting MCLKDIV of register EBICON. Therefore, chip can suitable for a wide frequency range of EBI device. If MCLK is set to HCLK/1, EBI signals are synchronized by positive edge of MCLK, else by negative edge of MCLK.

Operation and Access Timing Control

In the start of access, chip select (nCS) asserts to low and wait one MCLK for address setup time (tASU) for address stable. Then ALE asserts to high after address is stable and keeps for a period of time (tALE) for address latch. After latch address, ALE asserts to low and wait one MCLK for latch hold time (tLHD) and another one MCLK cycle (tA2D) that is inserted behind address hold time to be the bus turn-around time for address change to data. Then nRD asserts to low when read access or nWR asserts to low when write access. Then nRD or nWR asserts to high after keeps access time (tACC) for reading output stable or writing finish. After that, EBI signals keep for data access hold time (tAHD) and chip select asserts to high, address is released by current access control.

EBI controller provides a flexible timing control for different external device. In EBI timing control, tASU, tLHD and tA2D are fixed to 1 MCLK cycle, tAHD can modulate to 1~8 MCLK cycles by setting ExttAHD of register EXTTIME, tACC can modulate to 1~32 MCLK cycles by setting ExttACC of register EXTTIME, and tALE can modulate to 1~8 MCLK cycles by setting tALE of register EBICON.

Parameter	Value	Unit	Description
tASU	1	MCLK	Address Latch Setup Time.
tALE	1 ~ 8	MCLK	ALE High Period. Controlled by ExttALE of EBICON.
tLHD	1	MCLK	Address Latch Hold Time.
tA2D	1	MCLK	Address To Data Delay (Bus Turn-Around Time).
tACC	1 ~ 32	MCLK	Data Access Time. Controlled by ExttACC of EXTTIME.
tAHD	1 ~ 8	MCLK	Data Access Hold Time. Controlled by ExttAHD of EXTTIME.
IDLE	0 ~ 15	MCLK	Idle Cycle. Controlled by ExtIR2R and ExtIW2X of EXTTIME.

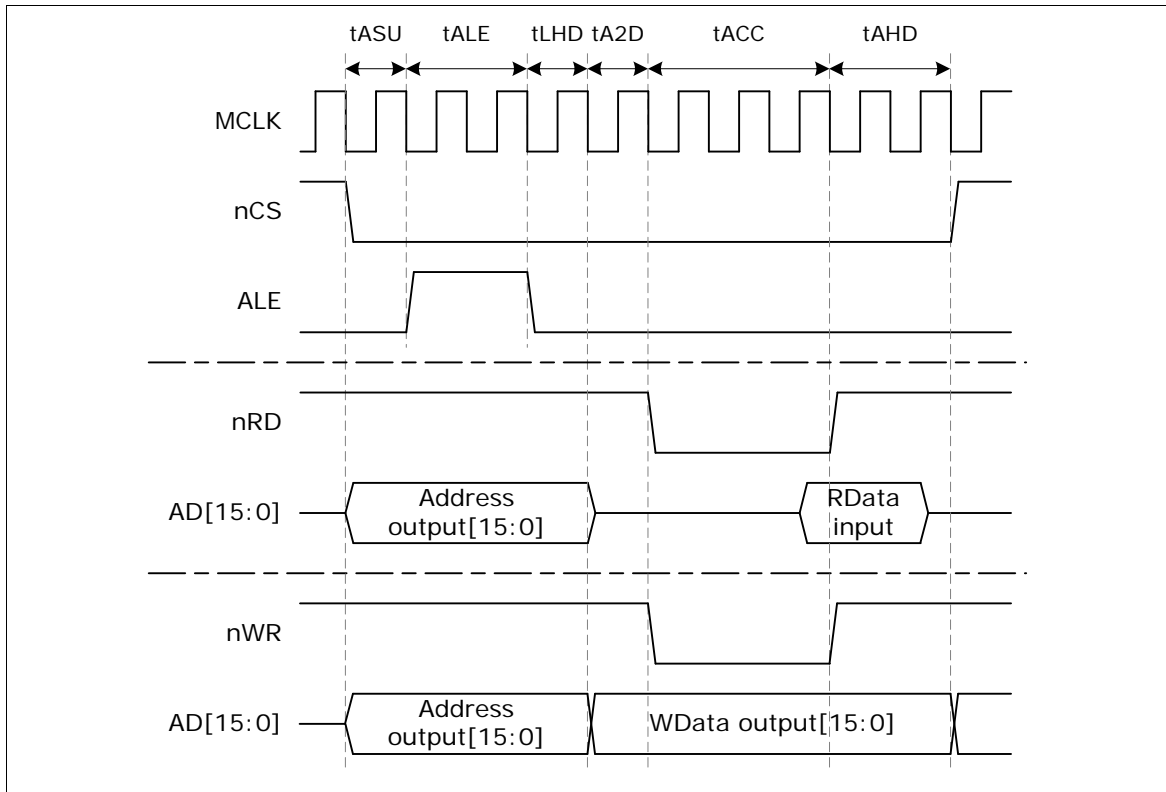

Figure 5-114 Timing Control Waveform for 16-bit Data Width

Figure 5-114 is an example of setting 16-bit data width. In this example, AD bus is used for being address[15:0] and data[15:0]. When ALE asserts to high, AD is address output. After address is latched, ALE asserts to low and the AD bus change to high impedance to wait device output data in read access operation, or it is used for being write data output.

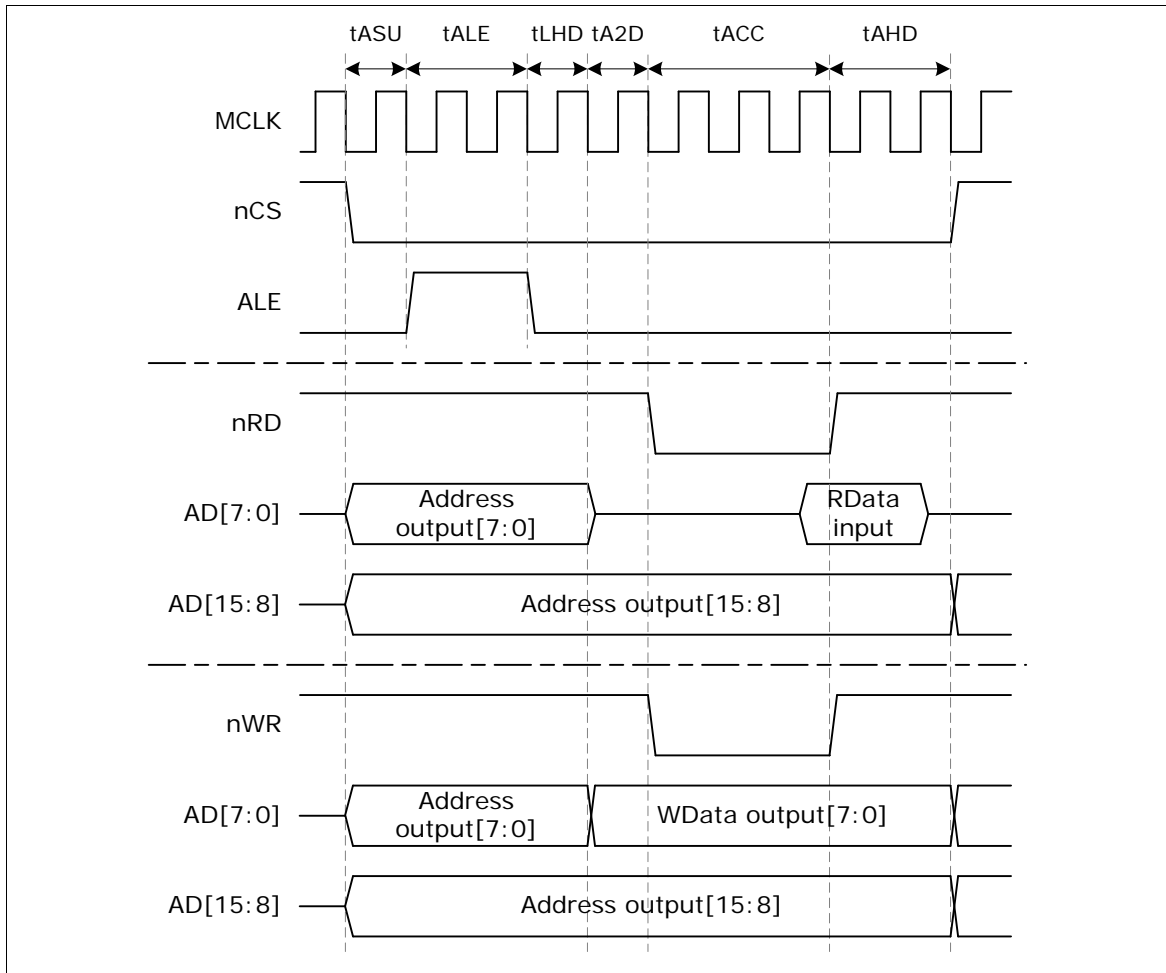

Figure 5-115 Timing Control Waveform for 8-bit Data Width

Figure 5-115 is an example of setting 8-bit data width. The difference between 8-bit and 16-bit data width is AD[15:8]. In 8-bit data width setting, AD[15:8] always be Address[15:8] output so that external latch need only 8-bit width.

Insert Idle Cycle

When EBI accessing continuously, there may occur bus conflict if the device access time is much slow with system operating. EBI controller supply additional idle cycle to solve this problem. During idle cycle, all control signals of EBI are inactive. Figure 5-116 show idle cycle as below:

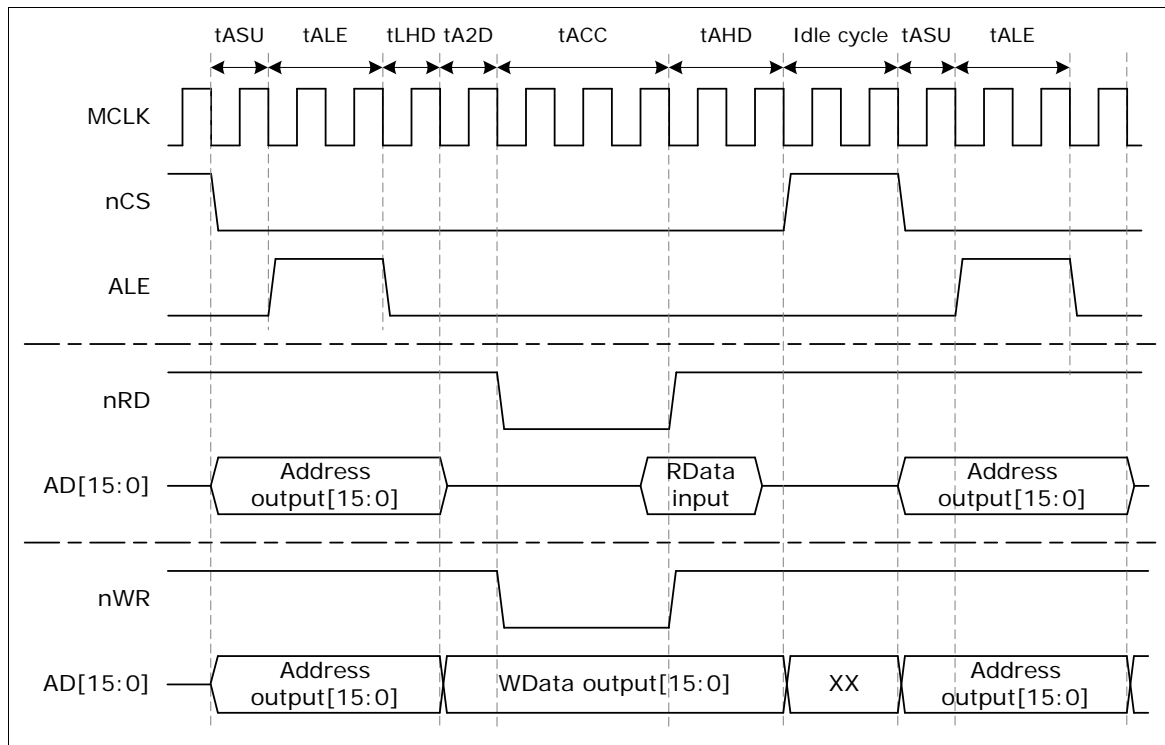

Figure 5-116 Timing Control Waveform for Insert Idle Cycle

There are two conditions that EBI can insert idle cycle by timing control:

1. After write access
2. After read access and before next read access

By setting ExtIW2X, and ExtIR2R of register EXTIME, the time of idle cycle can be specified from 0~15 MCLK.



5.19.5 Register Map

R: read only, W: write only, R/W: both read and write

Register	Offset	R/W	Description	Reset Value
EBI Base Address: EBI_BA = 0x5001_0000				
EBICON	EBI_BA+0x00	R/W	External Bus Interface General Control Register	0x0000_0000
EXTIME	EBI_BA+0x04	R/W	External Bus Interface Timing Control Register	0x0000_0000

5.19.6 Register Description

External Bus Interface CONTROL REGISTER (EBICON)

Register	Offset	R/W	Description	Reset Value
EBICON	EBI_BA+0x00	R/W	External Bus Interface General Control Register	0x0000_0000

31	30	29	28	27	26	25	24
Reserved							
23	22	21	20	19	18	17	16
Reversed					ExttALE		
15	14	13	12	11	10	9	8
Reversed					MCLKDIV		
7	6	5	4	3	2	1	0
Reversed						ExtBW16	ExtEN

Bits	Description							
[31:19]	Reserved	Reserved						
[18:16]	ExttALE	Expand Time of ALE The ALE width (tALE) to latch the address can be controlled by ExttALE. $tALE = (ExttALE+1)*MCLK$						
[15:11]	Reserved	Reserved						
[10:8]	MCLKDIV	External Output Clock Divider The frequency of EBI output clock is controlled by MCLKDIV as follows table: <table border="1" style="margin-left: 20px;"> <thead> <tr> <th>MCLKDIV</th> <th>Output clock (MCLK)</th> </tr> </thead> <tbody> <tr> <td>000</td> <td>HCLK/1</td> </tr> <tr> <td>001</td> <td>HCLK/2</td> </tr> </tbody> </table>	MCLKDIV	Output clock (MCLK)	000	HCLK/1	001	HCLK/2
MCLKDIV	Output clock (MCLK)							
000	HCLK/1							
001	HCLK/2							



		010	HCLK/4	
		011	HCLK/8	
		100	HCLK/16	
		101	HCLK/32	
		Others	default	
		Note: Default value of output clock is HCLK/1		
[7:2]	Reserved	Reserved		
[1]	ExtBW16	EBI data width 16-bit This bit defines if the data bus is 8-bit or 16-bit. 1 = EBI data width is 16-bit 0 = EBI data width is 8-bit		
[0]	ExtEN	EBI Enable This bit is the functional enable bit for EBI. 1 = EBI function Enabled 0 = EBI function Disabled		



External Bus Interface Timing CONTROL REGISTER (EXTIME)

Register	Offset	R/W	Description	Reset Value
EXTIME	EBI_BA+0x04	R/W	External Bus Interface Timing Control Register	0x0000_0000

31	30	29	28	27	26	25	24
Reserved				ExtIR2R			
23	22	21	20	19	18	17	16
Reversed							
15	14	13	12	11	10	9	8
ExtIW2X				Reversed	ExttAHD		
7	6	5	4	3	2	1	0
ExttACC				Reversed			

Bits	Description	
[31:28]	Reserved	Reserved
[27:24]	ExtIR2R	Idle State Cycle Between Read-Read When read action is finish and next action is going to read, idle state is inserted and nCS return to high if ExtIR2R is not zero. Idle state cycle = (ExtIR2R*MCLK)
[23:16]	Reserved	Reserved
[15:12]	ExtIW2X	Idle State Cycle After Write When write action is finished, idle state is inserted and nCS return to high if ExtIW2X is not zero. Idle state cycle = (ExtIW2X*MCLK)
[11]	Reserved	Reserved
[10:8]	ExttAHD	EBI Data Access Hold Time ExttAHD define data access hold time (tAHD). $tAHD = (ExttAHD + 1) * MCLK$
[7:3]	ExttACC	EBI Data Access Time ExttACC define data access time (tACC). $tACC = (ExttACC + 1) * MCLK$
[2:0]	Reserved	Reserved



6 FLASH MEMORY CONTROLLER (FMC)

6.1 Overview

The NuMicro™ NUC100 Series is equipped with 128/64/32K bytes on-chip embedded Flash for application program memory (APROM) that can be updated through ISP procedure. In System Programming (ISP) function enables user to update program memory when chip is soldered on PCB. After chip power on, Cortex-M0 CPU fetches code from APROM or LDROM decided by boot select (CBS) in Config0. Also, the NuMicro™ NUC100 Series also provides additional DATA Flash for user, to store some application dependent data before chip power off. For 128K bytes APROM device, the data flash is shared with original 128K program memory and its start address is configurable and defined by user application request in Config1. For 64K/32K bytes APROM device, the data flash is fixed at 4K.

6.2 Features

- Runs up to 50 MHz with zero wait state for continuous address read access
- 128/64/32KB application program memory (APROM)
- 4 KB In System Programming (ISP) loader program memory (LDROM)
- Configurable or fixed 4 KB data flash with 512 bytes page erase unit
- Programmable data flash start address for 128K APROM device
- In System Program (ISP) to update on chip Flash



6.3 Block Diagram

The flash memory controller consists of AHB slave interface, ISP control logic, writer interface and flash macro interface timing control logic. The block diagram of flash memory controller is shown as follows:

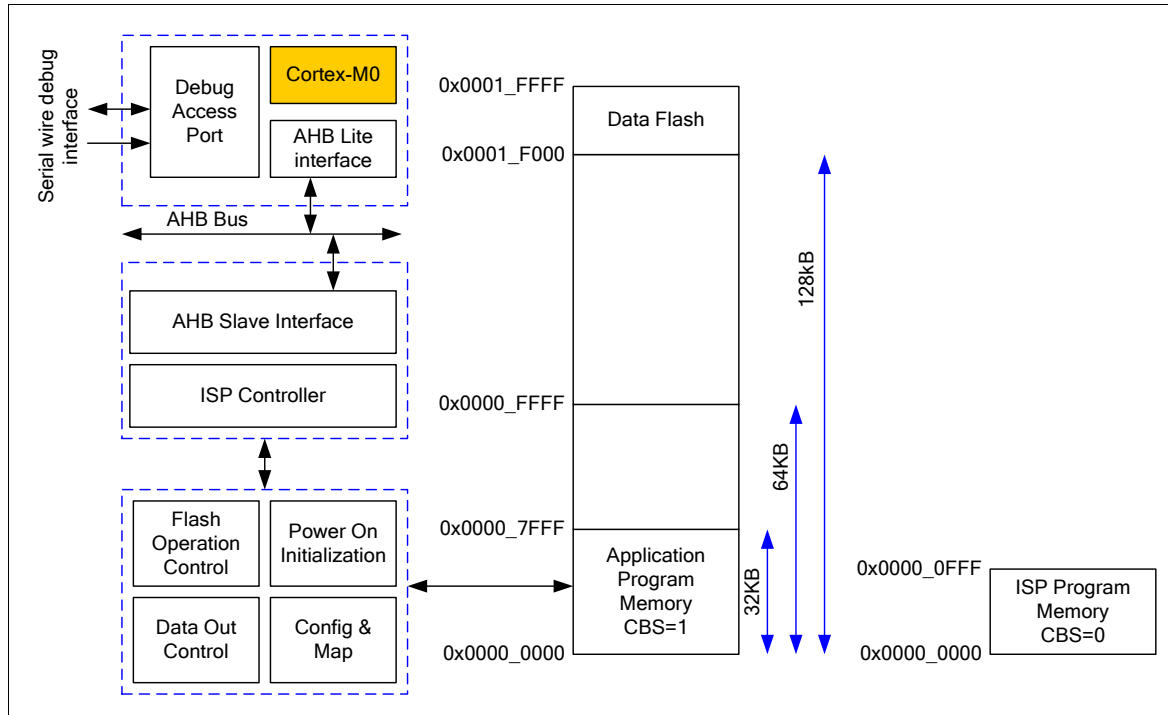

Figure 6-1 Flash Memory Control Block Diagram



6.4 Flash Memory Organization

The NuMicro™ NUC100 Series flash memory consists of Program memory (128/64/32KB), data flash, ISP loader program memory, user configuration. User configuration block provides several bytes to control system logic, such as flash security lock, boot select, Brown-out voltage level, data flash base address, etc. It works like a fuse for power on setting. It is loaded from flash memory to its corresponding control registers during chip power on. User can set these bits according to application request by writer before chip is mounted on PCB. The data flash start address and its size can be defined by user depends on application in 128KB APROM device. For 64/32KB APROM devices, its size is 4KB and start address is fixed at 0x0001_F000.

Block Name	Size	Start Address	End Address
AP-ROM	32/64/(128-0.5*N) KB	0x0000_0000	0x0000_7FFF (32KB) 0x0000_FFFF (64KB) DFBADR-1 (128KB if DFEN=0)
Reserved for future use	896KB	0x0002_0000	0x000F_FFFF
Data Flash	4/4/0.5*N KB	0x0001_F000 DFBADR	0x0001_FFFF
LD-ROM	4 KB	0x0010_0000	0x0010_0FFF
User Configuration	2 words	0x0030_0000	0x0030_0004

Table 6-1 Memory Address Map



The Flash memory organization is shown below.

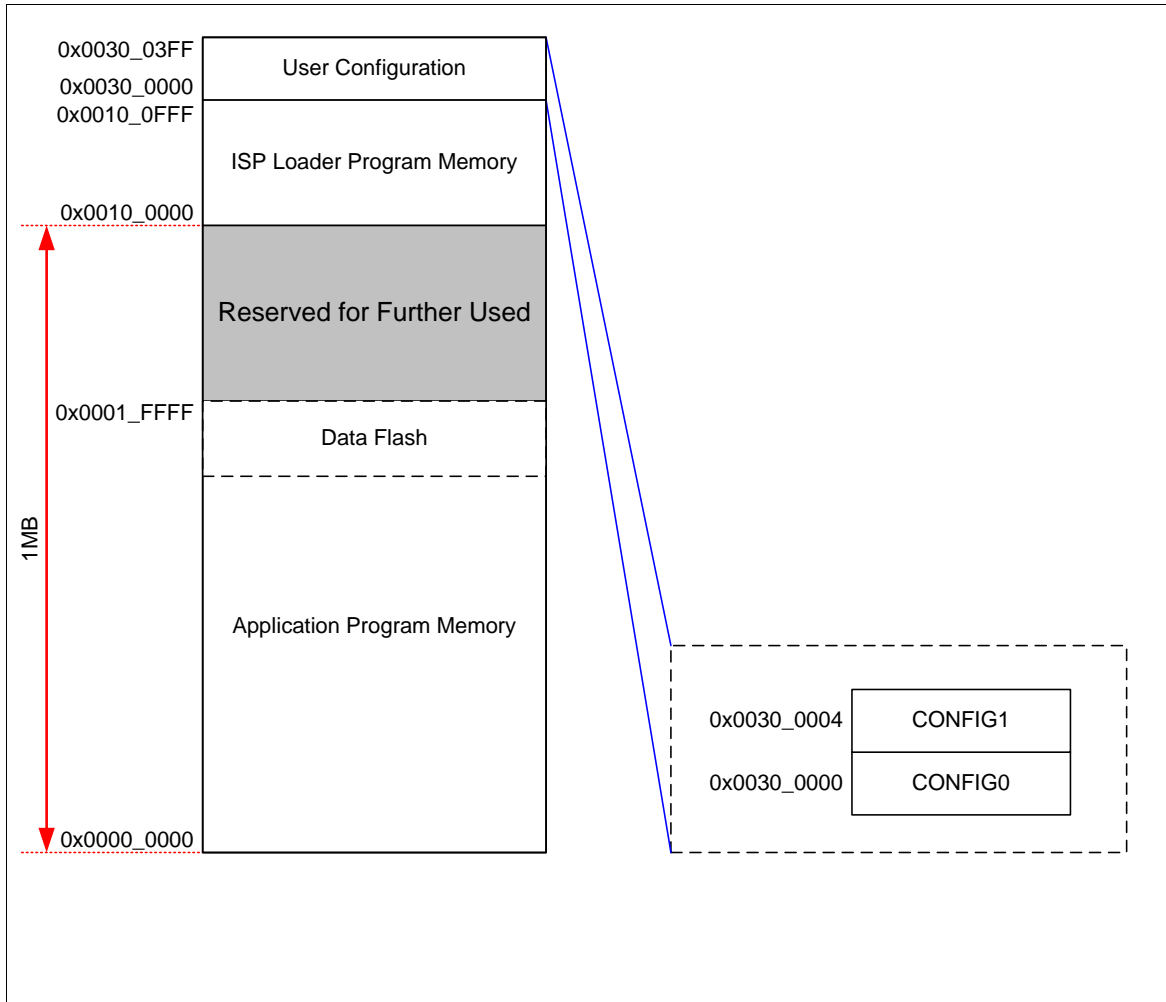

Figure 6-2 Flash Memory Organization



6.5 Boot Selection

The NuMicro™ NUC100 Series provides the In System Programming (ISP) feature to enable user to update program memory when chip is mounted on PCB. A dedicated 4KB program memory is used to store ISP firmware. Users can select to start program fetch from APROM or LDROM by (CBS) in Config0.

6.6 Data Flash

The NuMicro™ NUC100 Series provides data flash for user to store data. It is read/write through ISP procedure. The size of each erase unit is 512 bytes. When a word will be changed, all 128 words need to be copied to another page or SRAM in advance. For 128KB APROM device, the data flash and application program share the same 128KB memory, if DFEN bit in Config0 is enabled, the data flash base address is defined by DFBADR and application program memory size is $(128-0.5*N)$ KB and data flash size is $0.5*N$ KB. For 64/32KB APROM devices, data flash size is 4KB and start address is fixed at 0x0001_F000.

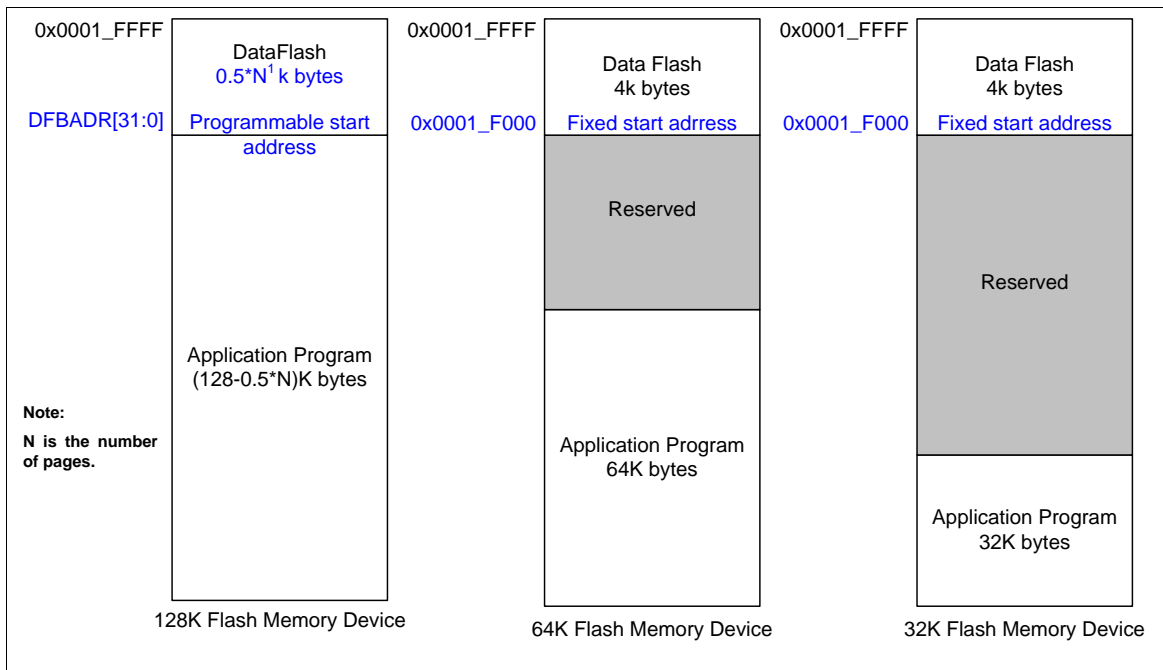

Figure 6-3 Flash Memory Structure



6.7 User Configuration

Config0 (Address = 0x0030_0000)

31	30	29	28	27	26	25	24
Reserved					CFOSC		
23	22	21	20	19	18	17	16
CBODEN	CBOV1	CBOV0	CBORST	Reserved			
15	14	13	12	11	10	9	8
Reserved							
7	6	5	4	3	2	1	0
CBS	Reserved					LOCK	DFEN

Config0	Address = 0x0030_0000											
Bits	Description											
[31:27]	Reserved	Reserved										
[26:24]	CFOSC	CPU Clock Source Selection after Reset										
		<table border="1"> <thead> <tr> <th>FOSC[2:0]</th><th>Clock Source</th></tr> </thead> <tbody> <tr> <td>000</td><td>External 4~24 MHz high speed crystal clock</td></tr> <tr> <td>111</td><td>Internal RC 22.1184 MHz high speed oscillator clock</td></tr> <tr> <td>Others</td><td>Reserved</td></tr> </tbody> </table>	FOSC[2:0]	Clock Source	000	External 4~24 MHz high speed crystal clock	111	Internal RC 22.1184 MHz high speed oscillator clock	Others	Reserved		
		FOSC[2:0]	Clock Source									
		000	External 4~24 MHz high speed crystal clock									
111	Internal RC 22.1184 MHz high speed oscillator clock											
Others	Reserved											
The value of CFOSC will be load to CLKSEL0.HCLK_S[2:0] in system register after any reset occurs.												
[23]	CBODEN	Brown-out Detector Enable 0= Brown-out detection Enabled after power on 1= Brown-out detection Disabled after power on										
[22:21]	CBOV1-0	Brown-out Voltage Selection										
		<table border="1"> <thead> <tr> <th>CBOV[1:0]</th><th>Brown-out Voltage</th></tr> </thead> <tbody> <tr> <td>11</td><td>4.5 V</td></tr> <tr> <td>10</td><td>3.8 V</td></tr> <tr> <td>01</td><td>2.7 V</td></tr> <tr> <td>00</td><td>2.2 V</td></tr> </tbody> </table>	CBOV[1:0]	Brown-out Voltage	11	4.5 V	10	3.8 V	01	2.7 V	00	2.2 V
		CBOV[1:0]	Brown-out Voltage									
		11	4.5 V									
10	3.8 V											
01	2.7 V											
00	2.2 V											
[20]	CBORST	Brown-out Reset Enable 0 = Brown-out reset Enabled after power on 1 = Brown-out reset Disabled after power on										
[19:8]	Reserved	Reserved										



[7]	CBS	Chip Boot Selection 0 = Chip boot from LDROM 1 = Chip boot from APROM
[6:2]	Reserved	Reserved
[1]	LOCK	Security Lock 0 = Flash data is locked 1 = Flash data is not locked When flash data is locked, only device ID, Config0 and Config1 can be read by writer and ICP through serial debug interface. Others data is locked as 0xFFFFFFFF. ISP can read data anywhere regardless of LOCK bit value.
[0]	DFEN	Data Flash Enable (Only for 128KB APROM Device) 0 = Data flash Enabled 1 = Data flash Disabled



Config1 (Address = 0x0030_0004)

31	30	29	28	27	26	25	24
Reserved							
23	22	21	20	19	18	17	16
Reserved				DFBADR.19	DFBADR.18	DFBADR.17	DFBADR.16
15	14	13	12	11	10	9	8
DFBADR.15	DFBADR.14	DFBADR.13	DFBADR.12	DFBADR.11	DFBADR.10	DFBADR.9	DFBADR.8
7	6	5	4	3	2	1	0
DFBADR.7	DFBADR.6	DFBADR.5	DFBADR.4	DFBADR.3	DFBADR.2	DFBADR.1	DFBADR.0

Config1	Address = 0x0030_0004	
Bits	Description	
[31:20]	Reserved	Reserved (It is mandatory to program 0x00 to these Reserved bits)
[19:0]	DFBADR	Data Flash Base Address (Only for 128KB APROM Device) For 128KB APROM device, its data flash base address is defined by user. Since on chip flash erase unit is 512 bytes, it is mandatory to keep bit 8-0 as 0. This configuration is only valid for 128KB flash device.

6.8 In System Program (ISP)

The program memory and data flash supports both in hardware programming and in system programming (ISP). Hardware programming mode uses gang-writers to reduce programming costs and time to market while the products enter the mass production state. However, if the product is just under development or the end product needs firmware updating in the hand of an end user, the hardware programming mode will make repeated programming difficult and inconvenient. ISP method makes it easy and possible. The NuMicro™ NUC100 Series supports ISP mode allowing a device to be reprogrammed under software control. Furthermore, the capability to update the application firmware makes wide range of applications possible.

ISP is performed without removing the microcontroller from the system. Various interfaces enable LDROM firmware to get new program code easily. The most common method to perform ISP is via UART along with the firmware in LDROM. General speaking, PC transfers the new APROM code through serial port. Then LDROM firmware receives it and re-programs into APROM through ISP commands. Nuvoton provides ISP firmware and PC application program for NuMicro™ NUC100 Series. It makes users quite easy perform ISP through Nuvoton ISP tool.

6.8.1 ISP Procedure

The NuMicro™ NUC100 Series supports booting from APROM or LDROM initially defined by user configuration bit (CBS). If user wants to update application program in APROM, he can write BS=1 and starts software reset to make chip boot from LDROM. The first step to start ISP function is write ISPEN bit to 1. S/W is required to write REGWRPROT register in Global Control Register (GCR, 0x5000_0100) with 0x59, 0x16 and 0x88 before writing ISPCON register. This procedure is used to protect flash memory from destroying owing to unintended write during power on/off duration.

Several error conditions are checked after software writes ISPGO bit. If error condition occurs, ISP operation is not been started and ISP fail flag will be set instead of. ISPPFF flag is cleared by s/w, it will not be over written in next ISP operation. The next ISP procedure can be started even ISPPFF bit keeps at 1. It is recommended that s/w to check ISPPFF bit and clear it after each ISP operation if it is set to 1.

When ISPGO bit is set, CPU will wait for ISP operation finish, during this period, peripheral still keeps working as usual. If any interrupt request occur, CPU will not service it till ISP operation finish. When ISP operation is finished, the ISPGO bit will be cleared by hardware automatically. User can know if ISP operation is finished by checking this bit. User should add ISB instruction next to the instruction which set 1 to ISPGO bit to ensure correct execution of the instructions following ISP operation.

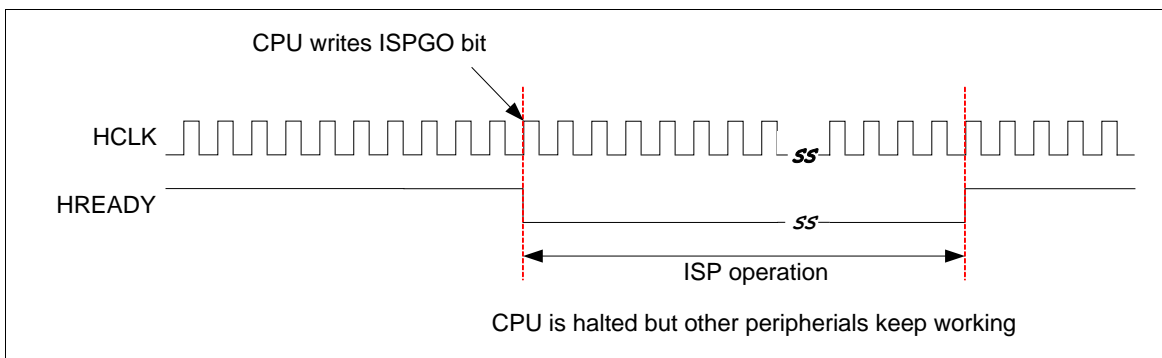

Note: The NuMicro™ NUC100 Series allows user to update CONFIG value by ISP.

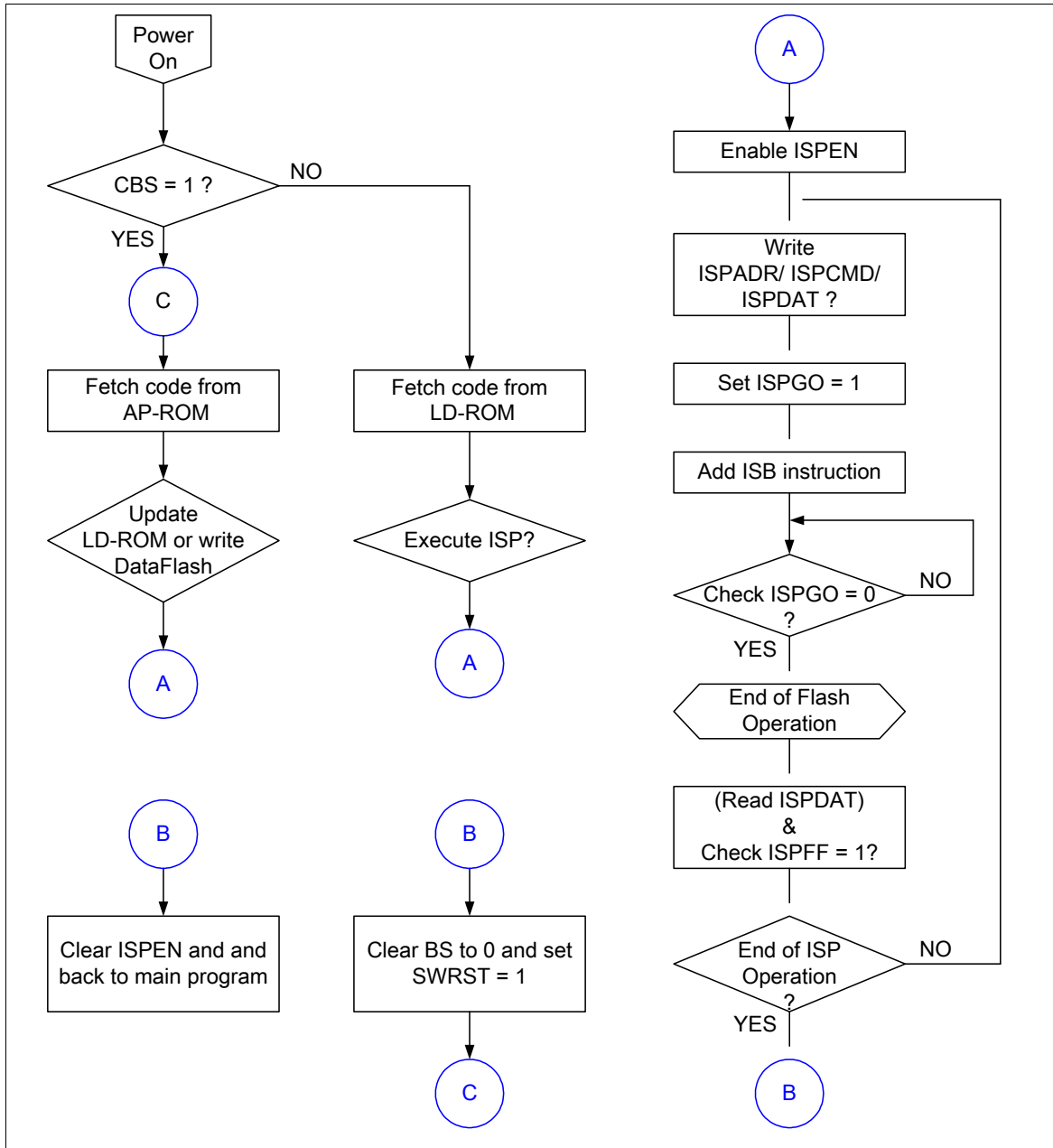



ISP Mode	ISPCMD			ISPADR			ISPDAT
	FOEN	FCEN	FCTRL[3:0]	A21	A20	A[19:0]	D[31:0]
FLASH Page Erase	1	0	0010	0	A20	Address in A[19:0]	x
FLASH Program	1	0	0001	0	A20	Address in A[19:0]	Data in D[31:0]
FLASH Read	0	0	0000	0	A20	Address in A[19:0]	Data out D[31:0]
CONFIG Page Erase	1	0	0010	1	1	Address in A[19:0]	x
CONFIG Program	1	0	0001	1	1	Address in A[19:0]	Data in D[31:0]
CONFIG Read	0	0	0000	1	1	Address in A[19:0]	Data out D[31:0]
Read Unique ID	0	0	0100	0	0	Address in A[19:0]	Data in Unique ID 0/1/2

Table 6-2 ISP Mode



6.9 Flash Control Register Map

R: read only, W: write only, R/W: both read and write

Register	Offset	R/W	Description	Reset Value
FMC Base Address: FMC_BA = 0x5000_C000				
ISPCON	FMC_BA+0x00	R/W	ISP Control Register	0x0000_0000
ISPADR	FMC_BA+0x04	R/W	ISP Address Register	0x0000_0000
ISPDAT	FMC_BA+0x08	R/W	ISP Data Register	0x0000_0000
ISPCMD	FMC_BA+0x0C	R/W	ISP Command Register	0x0000_0000
ISPTRG	FMC_BA+0x10	R/W	ISP Trigger Control Register	0x0000_0000
DFBADR	FMC_BA+0x14	R	Data Flash Start Address (APROM size is less than 128KB) ^(*)	0x0001_F000
FATCON	FMC_BA+0x18	R/W	Flash Access Time Control Register	0x0000_0000

Note: 1.0x00000000, where APROM size is equal to 128KB



6.10 Flash Control Register Description

ISP Control Register (ISPCON)

Register	Offset	R/W	Description	Reset Value
ISPCON	FMC_BA+0x00	R/W	ISP Control Register	0x0000_0000

31	30	29	28	27	26	25	24
Reserved							
23	22	21	20	19	18	17	16
Reserved							
15	14	13	12	11	10	9	8
Reserved							
7	6	5	4	3	2	1	0
Reserved	ISPPF	LDUEN	CFGUEN	APUEN	Reserved	BS	ISPEN

Bits	Description	
[31:7]	Reserved	Reserved
[6]	ISPPF	<p>ISP Fail Flag (Write-protection Bit)</p> <p>This bit is set by hardware when a triggered ISP meets any of the following conditions:</p> <ul style="list-style-type: none"> (1) APROM writes to itself if APUEN is set to 0 (2) LDROM writes to itself (3) CONFIG is erased/programmed if CFGUEN is set to 0 (4) Destination address is illegal, such as over an available range <p>Write 1 to clear.</p>
[5]	LDUEN	<p>LDROM Update Enable (Write-protection Bit)</p> <p>LDROM update enable bit.</p> <p>1 = LDROM can be updated when the chip runs in APROM</p> <p>0 = LDROM cannot be updated</p>
[4]	CFGUEN	<p>Enable Config-bits Update by ISP (Write-protection Bit)</p> <p>1 = Enabled ISP to update config-bits</p> <p>0 = Disabled ISP to update config-bits</p>
[3]	APUEN	<p>APROM Update Enable (Write-protection Bit)</p> <p>1 = APROM can be updated when the chip runs in APROM</p> <p>0 = APROM cannot be updated when the chip runs in APROM</p>
[2]	Reserved	Reserved



[1]	BS	<p>Boot Select (Write-protection Bit)</p> <p>Set/clear this bit to select next booting from LDROM/APROM, respectively. This bit also functions as chip booting status flag, which can be used to check where chip booted from. This bit is initiated with the inversed value of CBS in Config0 after any reset is happened except CPU reset (RSTS_CPU is 1) or system reset (RSTS_SYS) is happened</p> <p>1 = Boot from LDROM 0 = Boot from APROM</p>
[0]	ISPEN	<p>ISP Enable (Write-protection Bit)</p> <p>ISP function enable bit. Set this bit to enable ISP function.</p> <p>1 = ISP function Enabled 0 = ISP function Disabled</p>



ISP Address (ISPADR)

Register	Offset	R/W	Description	Reset Value
ISPADR	FMC_BA+0x04	R/W	ISP Address Register	0x0000_0000

31	30	29	28	27	26	25	24
ISPADR[31:24]							
23	22	21	20	19	18	17	16
ISPADR[23:16]							
15	14	13	12	11	10	9	8
ISPADR[15:8]							
7	6	5	4	3	2	1	0
ISPADR[7:0]							

Bits	Description	
[31:0]	ISPADR	<p>ISP Address</p> <p>The NuMicro™ NUC100 Series has a maximum 32Kx32 embedded flash, which supports word program only. ISPADR[1:0] must be kept 00b for ISP operation.</p>



ISP Data Register (ISPDAT)

Register	Offset	R/W	Description	Reset Value
ISPDAT	FMC_BA+0x08	R/W	ISP Data Register	0x0000_0000

31	30	29	28	27	26	25	24
ISPDAT[31:24]							
23	22	21	20	19	18	17	16
ISPDAT [23:16]							
15	14	13	12	11	10	9	8
ISPDAT [15:8]							
7	6	5	4	3	2	1	0
ISPDAT [7:0]							

Bits	Description
[31:0]	<p>ISPDAT</p> <p>ISP Data Write data to this register before ISP program operation Read data from this register after ISP read operation</p>



ISP Command (ISPCMD)

Register	Offset	R/W	Description	Reset Value
ISPCMD	FMC_BA+0x0C	R/W	ISP Command Register	0x0000_0000

31	30	29	28	27	26	25	24
Reserved							
23	22	21	20	19	18	17	16
Reserved							
15	14	13	12	11	10	9	8
Reserved							
7	6	5	4	3	2	1	0
Reserved		FOEN	FCEN	FCTRL			

Bits	Description																																				
[31:6]	Reserved	Reserved																																			
[5]	FOEN	ISP Command ISP command table is shown below:																																			
		<table border="1" style="width: 100%; text-align: center;"> <thead> <tr> <th>Operation Mode</th> <th>FOEN</th> <th>FCEN</th> <th colspan="4">FCTRL[3:0]</th> </tr> </thead> <tbody> <tr> <td>Read</td> <td>0</td> <td>0</td> <td>0</td> <td>0</td> <td>0</td> <td>0</td> </tr> <tr> <td>Program</td> <td>1</td> <td>0</td> <td>0</td> <td>0</td> <td>0</td> <td>1</td> </tr> <tr> <td>Page Erase</td> <td>1</td> <td>0</td> <td>0</td> <td>0</td> <td>1</td> <td>0</td> </tr> <tr> <td>Read Unique ID</td> <td>0</td> <td>0</td> <td>0</td> <td>1</td> <td>0</td> <td>0</td> </tr> </tbody> </table>	Operation Mode	FOEN	FCEN	FCTRL[3:0]				Read	0	0	0	0	0	0	Program	1	0	0	0	0	1	Page Erase	1	0	0	0	1	0	Read Unique ID	0	0	0	1	0	0
		Operation Mode	FOEN	FCEN	FCTRL[3:0]																																
		Read	0	0	0	0	0	0																													
		Program	1	0	0	0	0	1																													
Page Erase	1	0	0	0	1	0																															
Read Unique ID	0	0	0	1	0	0																															
[4]	FCEN	ISP Command																																			
[3:0]	FCTRL	ISP Command																																			



ISP Trigger Control Register (ISPTRG)

Register	Offset	R/W	Description	Reset Value
ISPTRG	FMC_BA+0x10	R/W	ISP Trigger Control Register	0x0000_0000

31	30	29	28	27	26	25	24
Reserved							
23	22	21	20	19	18	17	16
Reserved							
15	14	13	12	11	10	9	8
Reserved							
7	6	5	4	3	2	1	0
Reserved							ISPGO

Bits	Description
[31:1]	Reserved
[0]	<p>ISPGO</p> <p>ISP start trigger (Write-protection Bit) Write 1 to start ISP operation and this bit will be cleared to 0 by hardware automatically when ISP operation is finished.</p> <p>1 = ISP is on going 0 = ISP operation is finished</p> <p>This bit is the protected bit, It means programming this bit needs to write "59h", "16h", "88h" to address 0x5000_0100 to disable register protection. Refer to the register REGWRPROT at address GCR_BA+0x100</p>



Data Flash Base Address Register (DFBADR)

Register	Offset	R/W	Description	Reset Value
DFBADR	FMC_BA+0x14	R	Data Flash Start Address (APROM size is less than 128KB) ^(*)	0x0001_F000

31	30	29	28	27	26	25	24
DFBADR[31:23]							
23	22	21	20	19	18	17	16
DFBADR[23:16]							
15	14	13	12	11	10	9	8
DFBADR[15:8]							
7	6	5	4	3	2	1	0
DFBADR[7:0]							

Bits	Description
[31:0]	<p>Data Flash Base Address</p> <p>This register indicates data flash start address. It is a read only register.</p> <p>For 128KB flash memory device, the data flash size is defined by user configuration, register content is loaded from Config1 when chip power on but for 64/32KB device, it is fixed at 0x0001_F000.</p>



Flash Access Time Control Register (FATCON)

Register	Offset	R/W	Description	Reset Value
FATCON	FMC_BA+0x18	R/W	Flash Access Time Control Register	0x0000_0000

31	30	29	28	27	26	25	24
Reserved							
23	22	21	20	19	18	17	16
Reserved							
15	14	13	12	11	10	9	8
Reserved							
7	6	5	4	3	2	1	0
Reserved			LFOM	FATS[2:0]			FPSEN

Bits	Description																			
[31:5]	Reserved	Reserved																		
[4]	LFOM	<p>Low Frequency Optimization Mode (Write-protection Bit)</p> <p>When chip operation frequency is lower than 25 MHz, chip can work more efficiently by setting this bit to 1</p> <p>1 = Low Frequency Optimization mode Enabled 0 = Low Frequency Optimization mode Disabled</p>																		
[3:1]	FATS	<p>Flash Access Time Window Selection (Write-protection Bits)</p> <p>These bits are used to decide flash sense amplifier active duration.</p> <table border="1" style="width: 100%; text-align: center;"> <thead> <tr> <th>FATS</th> <th>Access Time window (ns)</th> </tr> </thead> <tbody> <tr><td>000</td><td>40</td></tr> <tr><td>001</td><td>50</td></tr> <tr><td>010</td><td>60</td></tr> <tr><td>011</td><td>70</td></tr> <tr><td>100</td><td>80</td></tr> <tr><td>101</td><td>90</td></tr> <tr><td>110</td><td>100</td></tr> <tr><td>111</td><td>Reserved</td></tr> </tbody> </table>	FATS	Access Time window (ns)	000	40	001	50	010	60	011	70	100	80	101	90	110	100	111	Reserved
		FATS	Access Time window (ns)																	
		000	40																	
		001	50																	
		010	60																	
		011	70																	
		100	80																	
		101	90																	
		110	100																	
111	Reserved																			
[0]	FPSEN	<p>Flash Power Save Enable (Write-protection Bit)</p> <p>If CPU clock is slower than 24 MHz, then s/w can enable flash power saving function.</p> <p>1 = Flash power saving Enabled 0 = Flash power saving Disabled</p>																		



7 ELECTRICAL CHARACTERISTICS

7.1 Absolute Maximum Ratings

PARAMETER	SYMBOL	MIN.	MAX	UNIT
DC Power Supply	$V_{DD}-V_{SS}$	-0.3	+7.0	V
Input Voltage	V_{IN}	$V_{SS}-0.3$	$V_{DD}+0.3$	V
Oscillator Frequency	$1/t_{CLCL}$	4	24	MHz
Operating Temperature	TA	-40	+85	°C
Storage Temperature	TST	-55	+150	°C
Maximum Current into V_{DD}		-	120	mA
Maximum Current out of V_{SS}			120	mA
Maximum Current sunk by a I/O pin			35	mA
Maximum Current sourced by a I/O pin			35	mA
Maximum Current sunk by total I/O pins			100	mA
Maximum Current sourced by total I/O pins			100	mA

Note: Exposure to conditions beyond those listed under absolute maximum ratings may adversely affects the lift and reliability of the device.



7.2 DC Electrical Characteristics

7.2.1 NuMicro™ NUC130/NUC140 DC Electrical Characteristics

($V_{DD}-V_{SS}=3.3\text{ V}$, $T_A = 25^\circ\text{C}$, $F_{OSC} = 50\text{ MHz}$ unless otherwise specified.)

PARAMETER	SYM.	SPECIFICATIONS				TEST CONDITIONS
		MIN.	TYP.	MAX.	UNIT	
Operation Voltage	V_{DD}	2.5		5.5	V	$V_{DD} = 2.5\text{ V} \sim 5.5\text{ V}$ up to 50 MHz
Power Ground	V_{SS} AV_{SS}	-0.3			V	
LDO Output Voltage	V_{LDO}	-10%	2.5	+10%	V	$V_{DD} > 2.7\text{ V}$
Analog Operating Voltage	AV_{DD}	0		V_{DD}	V	
Analog Reference Voltage	V_{ref}	0		AV_{DD}	V	
Operating Current Normal Run Mode at 50 MHz	I_{DD1}		51		mA	$V_{DD} = 5.5\text{ V}$ at 50 MHz, All IP and PLL Enabled, XTAL=12 MHz
	I_{DD2}		25		mA	$V_{DD} = 5.5\text{ V}$ at 50 MHz, All IP Disabled and PLL Enabled, XTAL=12 MHz
	I_{DD3}		48		mA	$V_{DD} = 3\text{ V}$ at 50 MHz, All IP and PLL Enabled, XTAL=12 MHz
	I_{DD4}		23		mA	$V_{DD} = 3\text{ V}$ at 50 MHz, All IP Disabled and PLL Enabled, XTAL=12 MHz
Operating Current Normal Run Mode at 12 MHz	I_{DD5}		19		mA	$V_{DD} = 5.5\text{ V}$ at 12 MHz, All IP Enabled and PLL Disabled, XTAL=12 MHz
	I_{DD6}		7		mA	$V_{DD} = 5.5\text{ V}$ at 12 MHz, All IP and PLL Disabled, XTAL=12 MHz
	I_{DD7}		17		mA	$V_{DD} = 3\text{ V}$ at 12 MHz, All IP Enabled and PLL Disabled, XTAL=12 MHz



PARAMETER	SYM.	SPECIFICATIONS				TEST CONDITIONS
		MIN.	TYP.	MAX.	UNIT	
	I _{DD8}		6		mA	V _{DD} = 3 V at 12 MHz, All IP and PLL Disabled, XTAL = 12 MHz
Operating Current Normal Run Mode at 4 MHz	I _{DD9}		11		mA	V _{DD} = 5 V at 4 MHz, All IP Enabled and PLL Disabled, XTAL = 4 MHz
	I _{DD10}		3		mA	V _{DD} = 5 V at 4 MHz, All IP and PLL Disabled, XTAL = 4 MHz
	I _{DD11}		10		mA	V _{DD} = 3 V at 4 MHz, All IP Enabled and PLL Disabled, XTAL = 4 MHz
	I _{DD12}		2.5		mA	V _{DD} = 3 V at 4 MHz, All IP and PLL Disabled, XTAL = 4 MHz
Operating Current Idle Mode at 50 MHz	I _{IDLE1}		35		mA	V _{DD} = 5.5 V at 50 MHz, All IP and PLL Enabled, XTAL = 12 MHz
	I _{IDLE2}		15		mA	V _{DD} =5.5 V at 50 MHz, All IP Disabled and PLL Enabled, XTAL = 12 MHz
	I _{IDLE3}		33		mA	V _{DD} = 3 V at 50 MHz, All IP and PLL Enabled, XTAL=12 MHz
	I _{IDLE4}		13		mA	V _{DD} = 3 V at 50 MHz, All IP Disabled and PLL Enabled, XTAL = 12 MHz
Operating Current Idle Mode at 12 MHz	I _{IDLE5}		10		mA	V _{DD} = 5.5 V at 12 MHz, All IP Enabled and PLL Disabled, XTAL=12 MHz
	I _{IDLE6}		4.5		mA	V _{DD} = 5.5 V at 12 MHz, All IP and PLL Disabled, XTAL = 12 MHz
	I _{IDLE7}		9		mA	V _{DD} = 3 V at 12 MHz, All IP Enabled and PLL Disabled, XTAL = 12 MHz
	I _{IDLE8}		3.5		mA	V _{DD} = 3 V at 12 MHz, All IP and PLL Disabled, XTAL = 12 MHz



PARAMETER	SYM.	SPECIFICATIONS				TEST CONDITIONS
		MIN.	TYP.	MAX.	UNIT	
Operating Current Idle Mode at 4 MHz	I _{IDLE9}		4		mA	V _{DD} = 5 V at 4 MHz, All IP Enabled and PLL Disabled, XTAL = 4 MHz
	I _{IDLE10}		2.5		mA	V _{DD} = 5 V at 4 MHz, All IP and PLL Disabled, XTAL = 4 MHz
	I _{IDLE11}		3.5		mA	V _{DD} = 3 V at 4 MHz, All IP Enabled and PLL Disabled, XTAL = 4 MHz
	I _{IDLE12}		1.5		mA	V _{DD} = 3 V at 4 MHz, All IP and PLL Disabled, XTAL = 4 MHz
Standby Current Power-down mode	I _{PWD1}		12		μA	V _{DD} = 5.5 V, RTC OFF, No load when BOV function Disabled
	I _{PWD2}		9		μA	V _{DD} = 3.3 V, RTC OFF, No load when BOV function Disabled
	I _{PWD3}				μA	V _{DD} = 5.5 V, RTC run , No load when BOV function Disabled
	I _{PWD4}				μA	V _{DD} = 3.3 V, RTC run , No load when BOV function Disabled
Input Current PA, PB, PC, PD, PE (Quasi-bidirectional mode)	I _{IN1}		-50	-60	μA	V _{DD} = 5.5 V, V _{IN} = 0 V or V _{IN} = V _{DD}
Input Current at /RESET ^[1]	I _{IN2}	-55	-45	-30	μA	V _{DD} = 3.3 V, V _{IN} = 0.45 V
Input Leakage Current PA, PB, PC, PD, PE	I _{LK}	-2	-	+2	μA	V _{DD} = 5.5 V, 0 < V _{IN} < V _{DD}
Logic 1 to 0 Transition Current PA~PE (Quasi-bidirectional mode)	I _{TL} ^[3]	-650	-	-200	μA	V _{DD} = 5.5 V, V _{IN} < 2.0 V
Input Low Voltage PA, PB, PC, PD, PE (TTL input)	V _{IL1}	-0.3	-	0.8	V	V _{DD} = 4.5 V
		-0.3	-	0.6		V _{DD} = 2.5 V
Input High Voltage PA, PB, PC, PD, PE (TTL input)	V _{IH1}	2.0	-	V _{DD} +0.2	V	V _{DD} = 5.5 V
		1.5	-	V _{DD} +0.2		V _{DD} = 3.0 V
Input Low Voltage PA, PB, PC, PD, PE (Schmitt input)	V _{IL2}	-0.5	-	0.3 V _{DD}	V	
Input High Voltage PA, PB, PC, PD, PE (Schmitt input)	V _{IH2}	0.7 V _{DD}	-	V _{DD} +0.5	V	
Hysteresis voltage of PA~PE (Schmitt input)	V _{HY}		0.2 V _{DD}		V	



PARAMETER	SYM.	SPECIFICATIONS				TEST CONDITIONS
		MIN.	TYP.	MAX.	UNIT	
Input Low Voltage XT1 ^[*2]	V _{IL3}	0	-	0.8	V	V _{DD} = 4.5 V
		0	-	0.4		V _{DD} = 3.0 V
Input High Voltage XT1 ^[*2]	V _{IH3}	3.5	-	V _{DD} +0.2	V	V _{DD} = 5.5 V
		2.4	-	V _{DD} +0.2		V _{DD} = 3.0 V
Input Low Voltage X32 ^[*2]	V _{IL4}	0	-	0.4	v	
Input High Voltage X32 ^[*2]	V _{IH4}	1.7		2.5	V	
Negative going threshold (Schmitt input), /RESET	V _{ILS}	-0.5	-	0.3 V _{DD}	V	
Positive going threshold (Schmitt input), /RESET	V _{IHS}	0.7 V _{DD}	-	V _{DD} +0.5	V	
Source Current PA, PB, PC, PD, PE (Quasi-bidirectional Mode)	I _{SR11}	-300	-370	-450	μA	V _{DD} = 4.5 V, V _S = 2.4 V
	I _{SR12}	-50	-70	-90	μA	V _{DD} = 2.7 V, V _S = 2.2 V
	I _{SR13}	-40	-60	-80	μA	V _{DD} = 2.5 V, V _S = 2.0 V
Source Current PA, PB, PC, PD, PE (Push-pull Mode)	I _{SR21}	-20	-24	-28	mA	V _{DD} = 4.5 V, V _S = 2.4 V
	I _{SR22}	-4	-6	-8	mA	V _{DD} = 2.7 V, V _S = 2.2 V
	I _{SR23}	-3	-5	-7	mA	V _{DD} = 2.5 V, V _S = 2.0 V
Sink Current PA, PB, PC, PD, PE (Quasi-bidirectional and Push-pull Mode)	I _{SK11}	10	16	20	mA	V _{DD} = 4.5 V, V _S = 0.45 V
	I _{SK12}	7	10	13	mA	V _{DD} = 2.7 V, V _S = 0.45 V
	I _{SK13}	6	9	12	mA	V _{DD} = 2.5 V, V _S = 0.45 V
Brown-out Voltage with BOV_VL [1:0] =00b	V _{BO2.2}	2.1	2.2	2.3	V	
Brown-out Voltage with BOV_VL [1:0] =01b	V _{BO2.7}	2.6	2.7	2.8	V	
Brown-out voltage with BOV_VL [1:0] =10b	V _{BO3.8}	3.6	3.8	4.0	V	
Brown-out Voltage with BOV_VL [1:0] =11b	V _{BO4.5}	4.3	4.5	4.7	V	
Hysteresis Range of BOD Voltage	V _{BH}	30	-	150	mV	V _{DD} = 2.5 V~5.5 V
Band-gap Voltage	V _{BG}	1.20	1.26	1.32	V	V _{DD} = 2.5 V~5.5 V

Note:

1. /RESET pin is a Schmitt trigger input.
2. Crystal Input is a CMOS input.
3. Pins PA, PB, PC, PD and PE can source a transition current when they are being externally driven from 1 to 0. In the



condition of $V_{DD}=5.5\text{ V}$, the transition current reaches its maximum value when V_{IN} approximates to 2 V.



7.3 AC Electrical Characteristics

7.3.1 External 4 ~ 24 MHz High Speed Oscillator

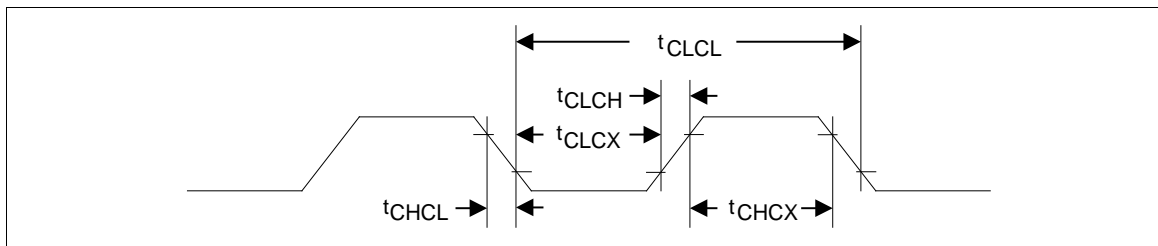

Note: Duty cycle is 50%.

SYMBOL	PARAMETER	CONDITIONS	MIN.	TYP.	MAX.	UNIT
t _{CHCX}	Clock High Time		20	-	-	nS
t _{CLCX}	Clock Low Time		20	-	-	nS
t _{CLCH}	Clock Rise Time		-	-	10	nS
t _{CHCL}	Clock Fall Time		-	-	10	nS

7.3.2 External 4 ~ 24 MHz High Speed Crystal

PARAMETER	CONDITIONS	MIN.	TYP.	MAX.	UNIT
Input clock frequency	External crystal	4	12	24	MHz
Temperature	-	-40	-	85	°C
V _{DD}	-	2.5	5	5.5	V
Operating current	12 MHz at V _{DD} = 5V	-	1	-	mA

7.3.2.1 Typical Crystal Application Circuits

CRYSTAL	C1	C2	R
4 MHz ~ 24 MHz	without	without	without

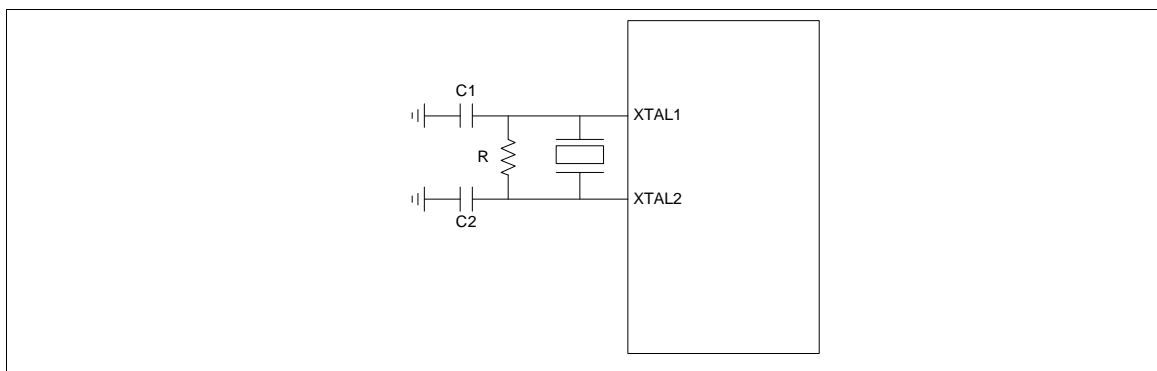

Figure 7-1 Typical Crystal Application Circuit

7.3.3 External 32.768 kHz Low Speed Crystal

PARAMETER	CONDITIONS	MIN.	TYP.	MAX.	UNIT
Input clock frequency	External crystal	-	32.768	-	kHz
Temperature	-	-40	-	85	°C
V _{DD}	-	2.5	-	5.5	V

7.3.4 Internal 22.1184 MHz High Speed Oscillator

PARAMETER	CONDITIONS	MIN.	TYP.	MAX.	UNIT
Supply voltage ^[1]	-	2.5	-	5.5	V
Center Frequency	-	-	22.1184	-	MHz
Calibrated Internal Oscillator Frequency	+25°C; V _{DD} = 5 V	-1	-	+1	%
	-40°C ~ +85°C; V _{DD} =2.5 V ~ 5.5 V	-3	-	+3	%
Operation Current	V _{DD} =5 V	-	500	-	uA

7.3.5 Internal 10 kHz Low Speed Oscillator

PARAMETER	CONDITIONS	MIN.	TYP.	MAX.	UNIT
Supply voltage ^[1]	-	2.5	-	5.5	V
Center Frequency	-	-	10	-	kHz
Calibrated Internal Oscillator Frequency	+25°C; V _{DD} = 5 V	-30	-	+30	%
	-40°C ~ +85°C; V _{DD} = 2.5 V~5.5 V	-50	-	+50	%

Note: Internal operation voltage comes from LDO.



7.4 Analog Characteristics

7.4.1 12-bit SARADC Specifications

SYMBOL	PARAMETER	MIN.	TYP.	MAX.	UNIT
-	Resolution	-	-	12	Bit
DNL	Differential nonlinearity error	-	±3	-	LSB
INL	Integral nonlinearity error	-	±4	-	LSB
EO	Offset error	-	±1	10	LSB
EG	Gain error (Transfer gain)	-	1	1.005	-
-	Monotonic	Guaranteed			
FADC	ADC clock frequency ($V_{DD}=5V/3V$)	-	-	16/8	MHz
FS	Sample rate	-	-	700	K SPS
V_{DDA}	Supply voltage	3	-	5.5	V
I_{DD}	Supply current (Avg.)	-	0.5	-	mA
I_{DDA}		-	1.5	-	mA
V_{REF}	Reference voltage	-	V_{DDA}	-	V
I_{REF}	Reference current (Avg.)	-	1	-	mA
V_{IN}	Input voltage	0	-	V_{REF}	V



7.4.2 LDO and Power Management Specifications

PARAMETER	MIN.	TYP.	MAX.	UNIT	NOTE
Input Voltage	2.7	5	5.5	V	V_{DD} input voltage
Output Voltage	-10%	2.5	+10%	V	$V_{DD} > 2.7$ V
Temperature	-40	25	85	°C	
Cbp	-	1	-	uF	Resr = 1Ω

Note:

1. It is recommended that a 10uF or higher capacitor and a 100nF bypass capacitor are connected between V_{DD} and the closest V_{SS} pin of the device.
2. For ensuring power stability, a 1uF or higher capacitor must be connected between LDO pin and the closest V_{SS} pin of the device.



7.4.3 Low Voltage Reset Specifications

PARAMETER	CONDITIONS	MIN.	TYP.	MAX.	UNIT
Operation voltage	-	1.7	-	5.5	V
Quiescent current	$V_{DD} = 5.5\text{ V}$	-	-	5	μA
Temperature	-	-40	25	85	$^{\circ}\text{C}$
Threshold voltage	Temperature = 25 $^{\circ}\text{C}$	1.7	2.0	2.3	V
	Temperature = -40 $^{\circ}\text{C}$	-	2.4	-	V
	Temperature = 85 $^{\circ}\text{C}$	-	1.6	-	V
Hysteresis	-	0	0	0	V

7.4.4 Brown-out Detector Specifications

PARAMETER	CONDITIONS	MIN.	TYP.	MAX.	UNIT
Operation voltage	-	2.5	-	5.5	V
Quiescent current	$AV_{DD} = 5.5\text{ V}$	-	-	125	μA
Temperature	-	-40	25	85	$^{\circ}\text{C}$
Brown-out voltage	BOV_VL[1:0] = 11	4.3	4.5	4.7	V
	BOV_VL [1:0] = 10	3.6	3.8	4.0	V
	BOV_VL [1:0] = 01	2.6	2.7	2.8	V
	BOV_VL [1:0] = 00	2.1	2.2	2.3	V
Hysteresis	-	30	-	150	mV

7.4.5 Power-on Reset (5V) Specifications

PARAMETER	CONDITIONS	MIN.	TYP.	MAX.	UNIT
Temperature	-	-40	25	85	$^{\circ}\text{C}$
Reset voltage	V+	-	2	-	V
Quiescent current	$V_{in} > \text{reset voltage}$	-	1	-	nA



7.4.6 Temperature Sensor Specifications

PARAMETER	CONDITIONS	MIN.	TYP.	MAX.	UNIT
Supply voltage ^[1]		2.5	-	5.5	V
Temperature		-40	-	125	°C
Current consumption		6.4	-	10.5	uA
Gain			-1.76		mV/°C
Offset	Temp = 0 °C		720		mV

Note: Internal operation voltage comes from LDO.

7.4.7 Comparator Specifications

PARAMETER	CONDITIONS	MIN.	TYP.	MAX.	UNIT
Temperature	-	-40	25	85	°C
V _{DD}	-	2.4	3	5.5	V
V _{DD} current	20 uA at V _{DD} = 3 V	-	20	40	uA
Input offset voltage	-	-	5	15	mV
Output swing	-	0.1	-	V _{DD} -0.1	V
Input common mode range	-	0.1	-	V _{DD} -1.2	V
DC gain	-	-	70	-	dB
Propagation delay	V _{CM} = 1.2 V, V _{DIFF} = 0.1 V	-	200	-	ns
Comparison voltage	20 mV at V _{CM} = 1 V 50 mV at V _{CM} = 0.1 V 50 mV at V _{CM} = V _{DD} -1.2 at 10 mV for non-hysteresis	10	20	-	mV
Hysteresis	One bit control W/O and W. hysteresis at V _{CM} =0.4 V ~ V _{DD} -1.2 V	-	±10	-	mV
Wake-up time	C _{INP} = 1.3 V C _{INN} = 1.2 V	-	-	2	us



7.4.8 USB PHY Specifications

7.4.8.1 USB DC Electrical Characteristics

SYMBOL	PARAMETER	CONDITIONS	MIN.	TYP.	MAX.	UNIT
V _{IH}	Input high (driven)		2.0			V
V _{IL}	Input low				0.8	V
V _{DI}	Differential input sensitivity	PADP-PADM	0.2			V
V _{CM}	Differential common-mode range	Includes V _{DI} range	0.8		2.5	V
V _{SE}	Single-ended receiver threshold		0.8		2.0	V
	Receiver hysteresis			200		mV
V _{OL}	Output low (driven)		0		0.3	V
V _{OH}	Output high (driven)		2.8		3.6	V
V _{CRS}	Output signal cross voltage		1.3		2.0	V
R _{PU}	Pull-up resistor		1.425		1.575	kΩ
V _{TRM}	Termination Voltage for upstream port pull up (RPU)		3.0		3.6	V
Z _{DRV}	Driver output resistance	Steady state drive*		10		Ω
C _{IN}	Transceiver capacitance	Pin to GND			20	pF

*Driver output resistance does not include series resistor resistance.

7.4.8.2 USB Full-Speed Driver Electrical Characteristics

SYMBOL	PARAMETER	CONDITIONS	MIN.	TYP.	MAX.	UNIT
T _{FR}	Rise Time	C _L =50p	4		20	ns
T _{FF}	Fall Time	C _L =50p	4		20	ns
T _{FRFF}	Rise and fall time matching	T _{FRFF} =T _{FR} /T _{FF}	90		111.11	%

7.4.8.3 USB Power Dissipation

SYMBOL	PARAMETER	CONDITIONS	MIN.	TYP.	MAX.	UNIT
I _{VDDREG} (Full Speed)	V _{DDD} and V _{DDREG} Supply Current (Steady State)	Standby		50		uA
		Input mode				uA
		Output mode				uA



7.5 Flash DC Electrical Characteristics

SYMBOL	PARAMETER	CONDITIONS	MIN.	TYP.	MAX.	UNIT
N_{endu}	Endurance		10000			cycles ^[1]
T_{ret}	Retention time	Temp = 25 °C	100			year
T_{erase}	Page erase time		20		40	ms
T_{mass}	Mass erase time		40	50	60	ms
T_{prog}	Program time		35	40	55	us
V_{dd}	Supply voltage		2.25	2.5	2.75	V ^[2]
I_{dd1}	Read current				14	mA
I_{dd2}	Program/Erase current				7	mA
I_{pd}	Power down current				10	uA

1. Number of program/erase cycles.
2. V_{dd} is source from chip LDO output voltage.
3. This table is guaranteed by design, not test in production.



7.6 SPI Dynamic Characteristics

SYMBOL	PARAMETER	MIN.	TYP.	MAX.	UNIT
SPI Master mode ($V_{DD} = 4.5V \sim 5.5V$, 30pF loading Capacitor)					
t_{DS}	Data setup time	4	2	-	ns
t_{DH}	Data hold time	0	-	-	ns
t_V	Data output valid time	-	7	11	ns
SPI Master mode ($V_{DD} = 3.0V \sim 3.6V$, 30pF loading Capacitor)					
t_{DS}	Data setup time	5	3	-	ns
t_{DH}	Data hold time	0	-	-	ns
t_V	Data output valid time	-	13	18	ns
SPI Slave mode ($V_{DD} = 4.5V \sim 5.5V$, 30pF loading Capacitor)					
t_{DS}	Data setup time	0	-	-	ns
t_{DH}	Data hold time	$2 \cdot PCLK + 4$	-	-	ns
t_V	Data output valid time	-	$2 \cdot PCLK + 11$	$2 \cdot PCLK + 19$	ns
SPI Slave mode ($V_{DD} = 3.0V \sim 3.6V$, 30pF loading Capacitor)					
t_{DS}	Data setup time	0	-	-	ns
t_{DH}	Data hold time	$2 \cdot PCLK + 6$	-	-	ns
t_V	Data output valid time	-	$2 \cdot PCLK + 19$	$2 \cdot PCLK + 25$	ns

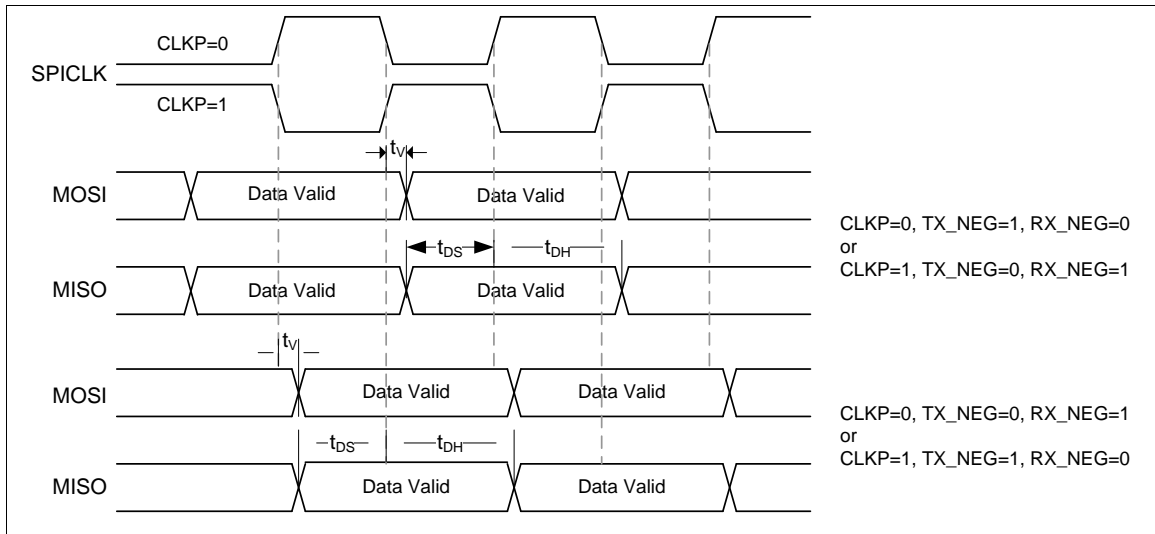

Figure 7-2 SPI Master Dynamic Characteristics timing

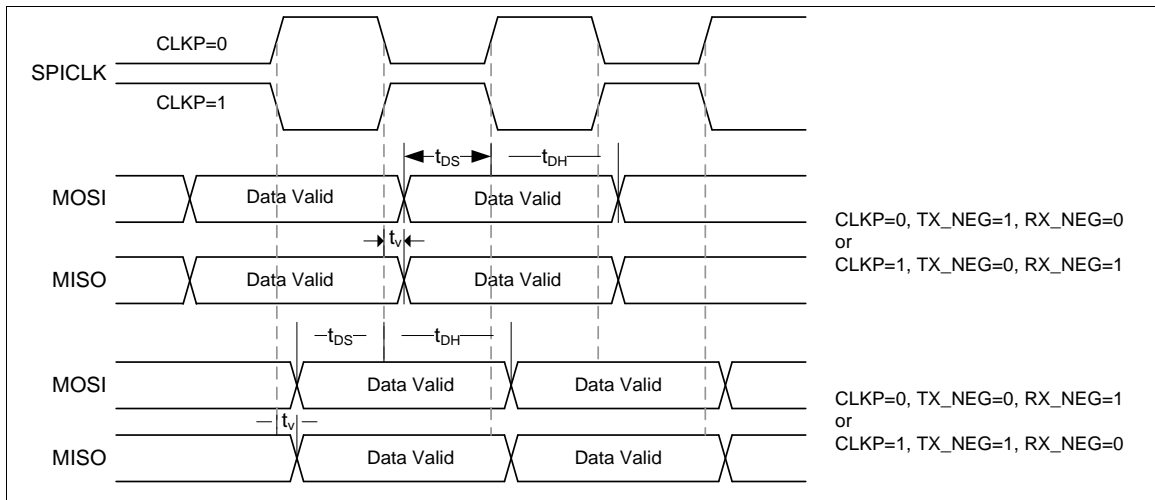
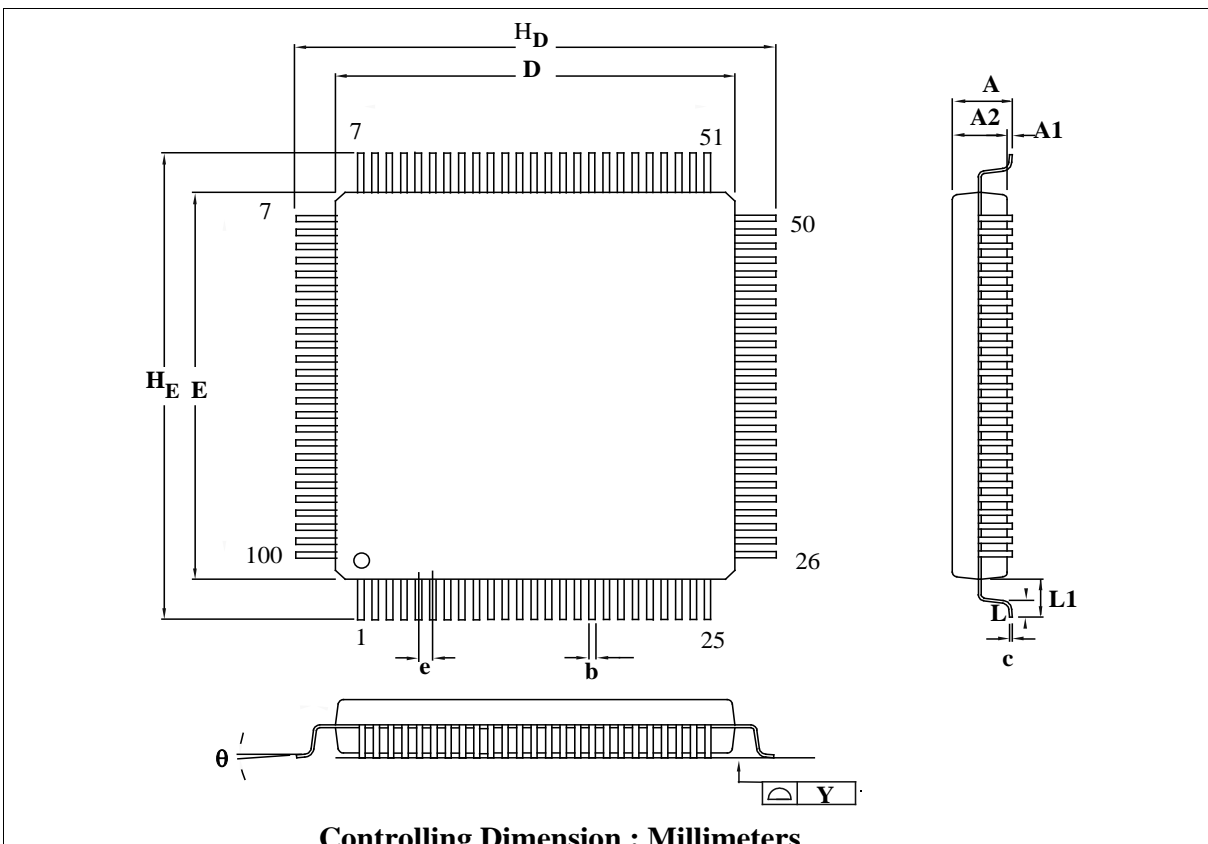

Figure 7-3 SPI Slave Dynamic Characteristics Timing



8 PACKAGE DIMENSIONS

8.1 100L LQFP (14x14x1.4 mm footprint 2.0 mm)



Controlling Dimension : Millimeters

Symbol	Dimension in inch			Dimension in mm		
	Min	Nom	Max	Min	Nom	Max
A	—	—	0.063	—	—	1.60
A1	0.002	—	—	0.05	—	—
A2	0.053	0.055	0.057	1.35	1.40	1.45
b	0.007	0.009	0.011	0.17	0.22	0.27
c	0.004	0.006	0.008	0.10	0.15	0.20
D	0.547	0.551	0.556	13.90	14.00	14.10
E	0.547	0.551	0.556	13.90	14.00	14.10
e	—	0.020	—	—	0.50	—
H_D	0.622	0.630	0.638	15.80	16.00	16.20
H_E	0.622	0.630	0.638	15.80	16.00	16.20
L	0.018	0.024	0.030	0.45	0.60	0.75
L1	—	0.039	—	—	1.00	—
y	—	—	0.004	—	—	0.10
θ	0°	—	7°	0°	—	7°



8.2 64L LQFP (10x10x1.4mm footprint 2.0 mm)

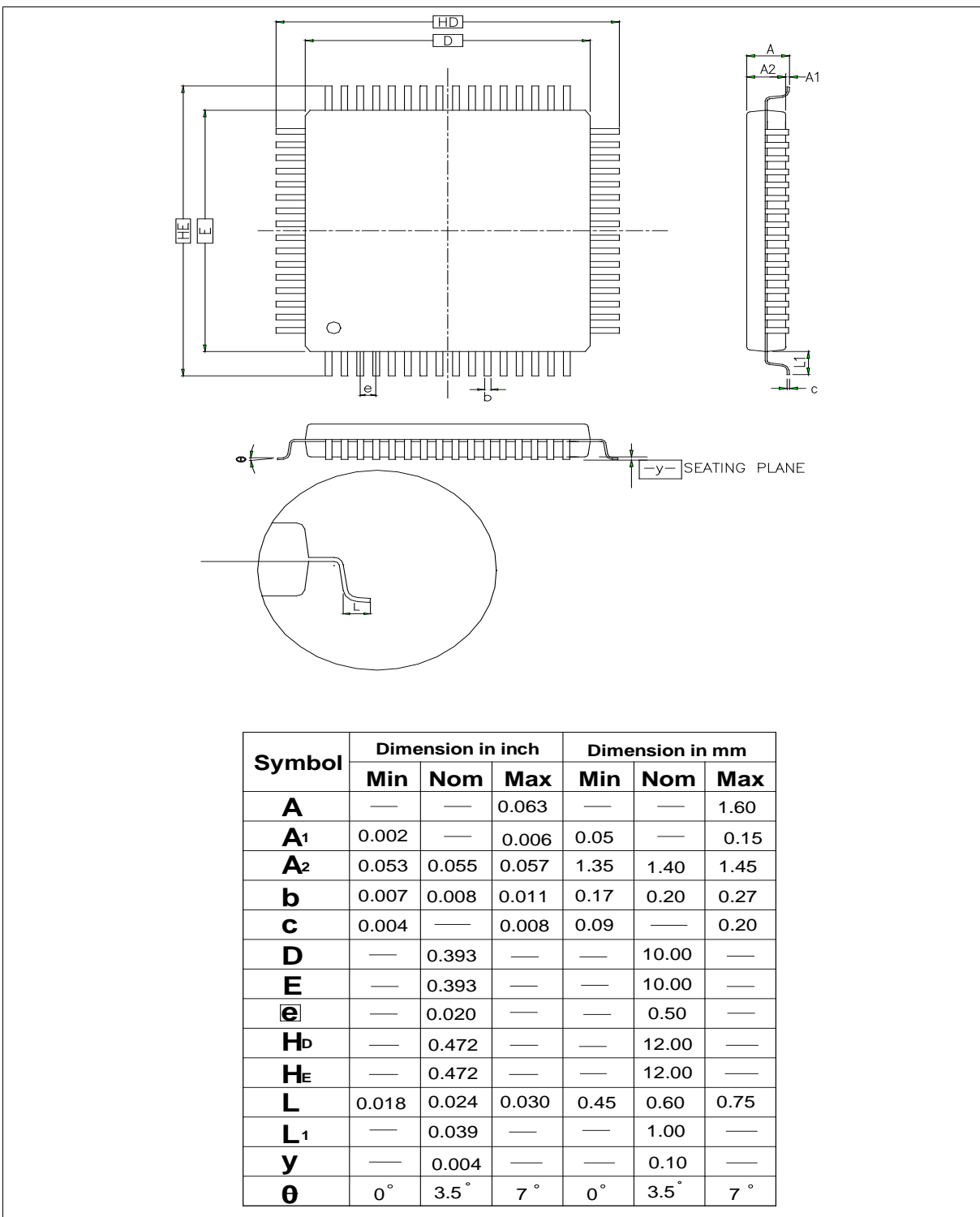



8.3 48L LQFP (7x7x1.4 mm footprint 2.0 mm)

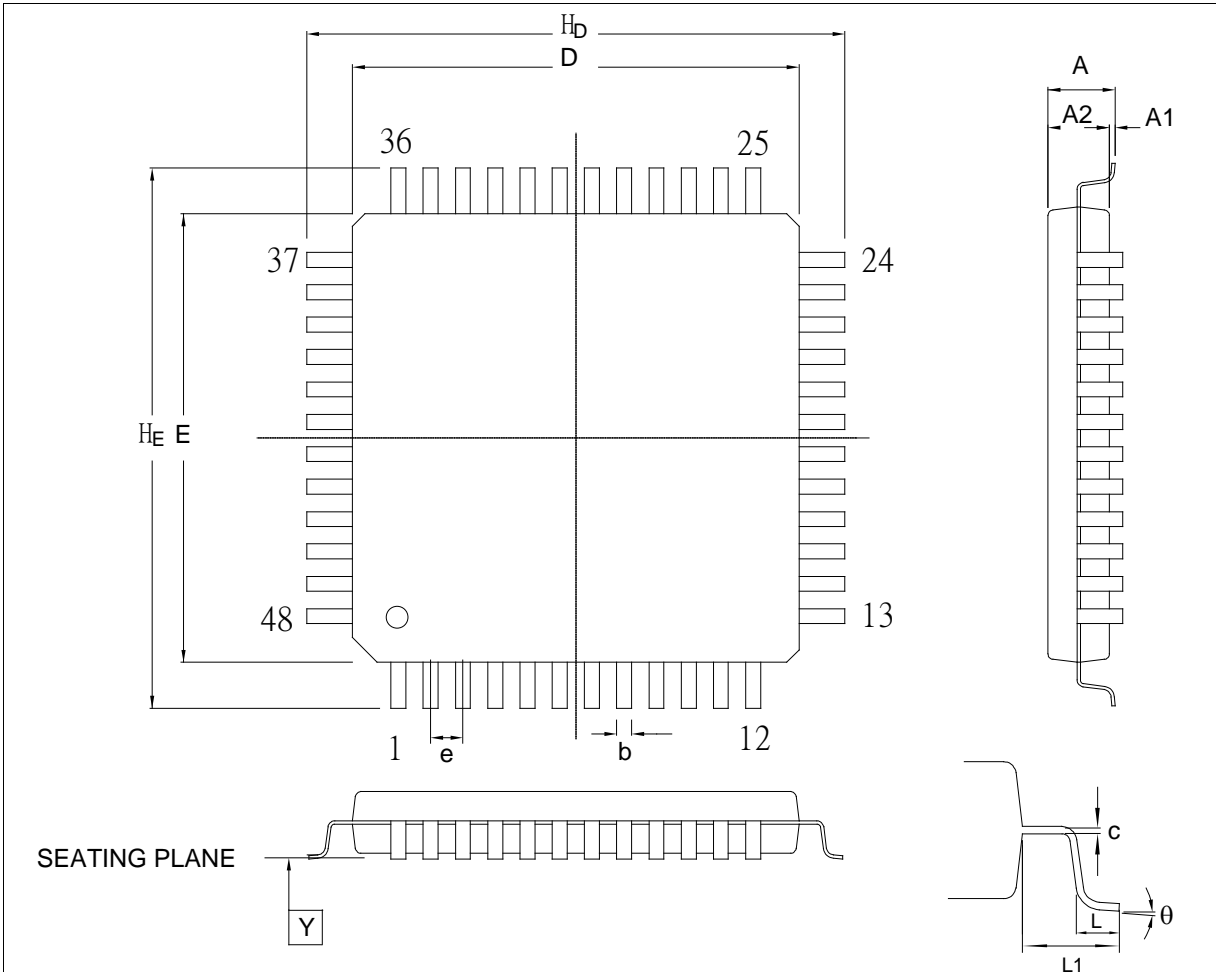

Controlling dimension : Millimeters

Symbol	Dimension in inch			Dimension in mm		
	Min	Nom	Max	Min	Nom	Max
A	—	—	—	—	—	—
A₁	0.002	0.004	0.006	0.05	0.10	0.15
A₂	0.053	0.055	0.057	1.35	1.40	1.45
b	0.006	0.008	0.010	0.15	0.20	0.25
c	0.004	0.006	0.008	0.10	0.15	0.20
D	0.272	0.276	0.280	6.90	7.00	7.10
E	0.272	0.276	0.280	6.90	7.00	7.10
e	0.014	0.020	0.026	0.35	0.50	0.65
H_b	0.350	0.354	0.358	8.90	9.00	9.10
H_e	0.350	0.354	0.358	8.90	9.00	9.10
L	0.018	0.024	0.030	0.45	0.60	0.75
L₁	—	0.039	—	—	1.00	—
Y	—	—	0.004	—	—	0.10
θ	0°	—	7°	0°	—	7°





9 REVISION HISTORY

REVISION	DATE	DESCRIPTION
V2.00	May 04, 2011	<ol style="list-style-type: none"> 1. Originated from the NUC100 series TRM 2. Updated CAN peripheral to BOSCH C-CAN
V2.01	June 14, 2011	<ol style="list-style-type: none"> 1. Revised the ISPCON.BS and ISPCON.ISPFF description 2. Modified the temperature sensor spec 3. Revised the pin description for multi-function T2EX, T3EX, nRD, nWR 4. Updated the title of SPI Dynamic Characteristics 5. Updated BOD spec
V2.02	Jan. 2, 2012	<ol style="list-style-type: none"> 1. Updated the WDT block diagram 2. Released PDMA/debug register in UA_ISR register 3. Removed the feature “Dynamic priority changing” for NVIC 4. Modified the INIR description in RTC register 5. Modified the description for RTC compensation 6. Revised the R/W description for TDR and TCAP 7. Revised the TWKE description 8. Revised the AER description 9. Revised AER effect from 512 clock to 1024 clock 10. Modified the ADC analog characteristic spec 11. Modified the description of PWM sample procedure 12. Removed the TX_FULLL and RX_FULLL description, and revised the TX_POINTER and RX_POINTER description 13. Removed SPI FIFO mode
V2.04	May 04, 2012	<ol style="list-style-type: none"> 1. Updated all format and description
V2.05	Aug 22, 2013	<ol style="list-style-type: none"> 1. Updated the PDID table 2. Updated UART_CLK / (A+2), A must >=7 3. Remove ET and PT register



Important Notice

Nuvoton Products are neither intended nor warranted for usage in systems or equipment, any malfunction or failure of which may cause loss of human life, bodily injury or severe property damage. Such applications are deemed, "Insecure Usage".



Insecure usage includes, but is not limited to: equipment for surgical implementation, atomic energy control instruments, airplane or spaceship instruments, the control or operation of dynamic, brake or safety systems designed for vehicular use, traffic signal instruments, all types of safety devices, and other applications intended to support or sustain life.

All Insecure Usage shall be made at customer's risk, and in the event that third parties lay claims to Nuvoton as a result of customer's Insecure Usage, customer shall indemnify the damages and liabilities thus incurred by Nuvoton.

*Please note that all data and specifications are subject to change without notice.
All the trademarks of products and companies mentioned in this datasheet belong to their respective owners.*

Looking for pricing, stock, or lifecycle information?

Click below to explore more details on WIN SOURCE:

-  [View NUC130RD2CN on WIN SOURCE](#)
-  [Nuvoton Technology Corporation of America Information](#)

Optimize Your Supply Chain with WIN SOURCE Solutions

-  Global Sourcing Solution
-  Obsolete Management
-  Cost Control Management
-  Shortage Management
-  Alternative Solution
-  Excess Inventory Management