



**THE DATASHEET OF
NCV7510DWR2G**



NCV7510

FlexMOS™ Programmable Peak and Hold PWM MOSFET Predriver

The NCV7510 high side MOSFET predriver is a fully programmable automotive grade product for driving solenoids or other unipolar actuators. The product is optimized for common-rail diesel fuel injection applications and includes an additional synchronous clamp MOSFET predriver. Peak and hold currents, peak dwell time and other features are programmable via the device's SPI port. Load current is continuously sampled and compared to the programmable 7-bit peak/hold DAC values while the load self-modulates to maintain the desired currents at each of the peak and hold points. Passive fault diagnostics monitor and protect the MOSFETs when a fault is detected. Fault data is available via SPI and an open-drain FAULT output provides immediate fault notification to a host controller.

The FlexMOS family of products offers application scalability through choice of external MOSFETs.

Features

- 4 MHz 16-Bit SPI Communication
- 3.3 / 5.0 V Compatible Inputs
- Bootstrap for High Side MOSFET
- Synchronous Clamp Drive
- Cross Conduction Suppression
- Self-Protection
 - Overcurrent and Overvoltage
 - Antisaturation
- Fault Diagnostics
 - Short to Battery/GND
 - Open Circuit / Shorted Load
 - Overvoltage
- Open-Drain FAULT Output
- Programmable
 - Peak / Hold Current PWM Thresholds
 - Overcurrent and Overvoltage
 - Antisaturation Thresholds
 - Peak Dwell Time
- NCV Prefix for Automotive and Other Applications Requiring Site and Control Changes
- These are Pb-Free Devices

Benefits

- Scalable by Choice of MOSFETs
- Reduced Load Power Consumption
- Low Host Controller Overhead
- Low Standby Current



ON Semiconductor®

<http://onsemi.com>

MARKING DIAGRAM

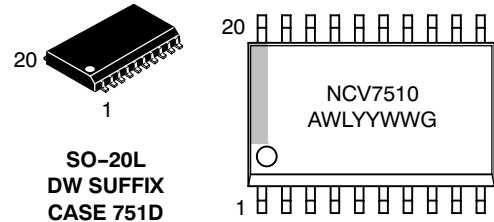

A = Assembly Location
WL = Wafer Lot
YY = Year
WW = Work Week
G = Pb-Free Package

PIN CONNECTIONS

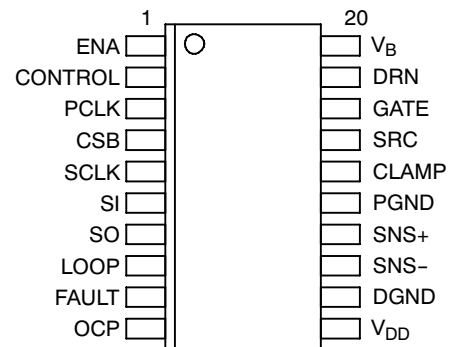

ORDERING INFORMATION

Device	Package	Shipping†
NCV7510DWG	SO-20L (Pb-Free)	37 Units/Rail
NCV7510DWR2G	SO-20L (Pb-Free)	1000 Tape & Reel

†For information on tape and reel specifications, including part orientation and tape sizes, please refer to our Tape and Reel Packaging Specification Brochure, BRD8011/D.

NCV7510

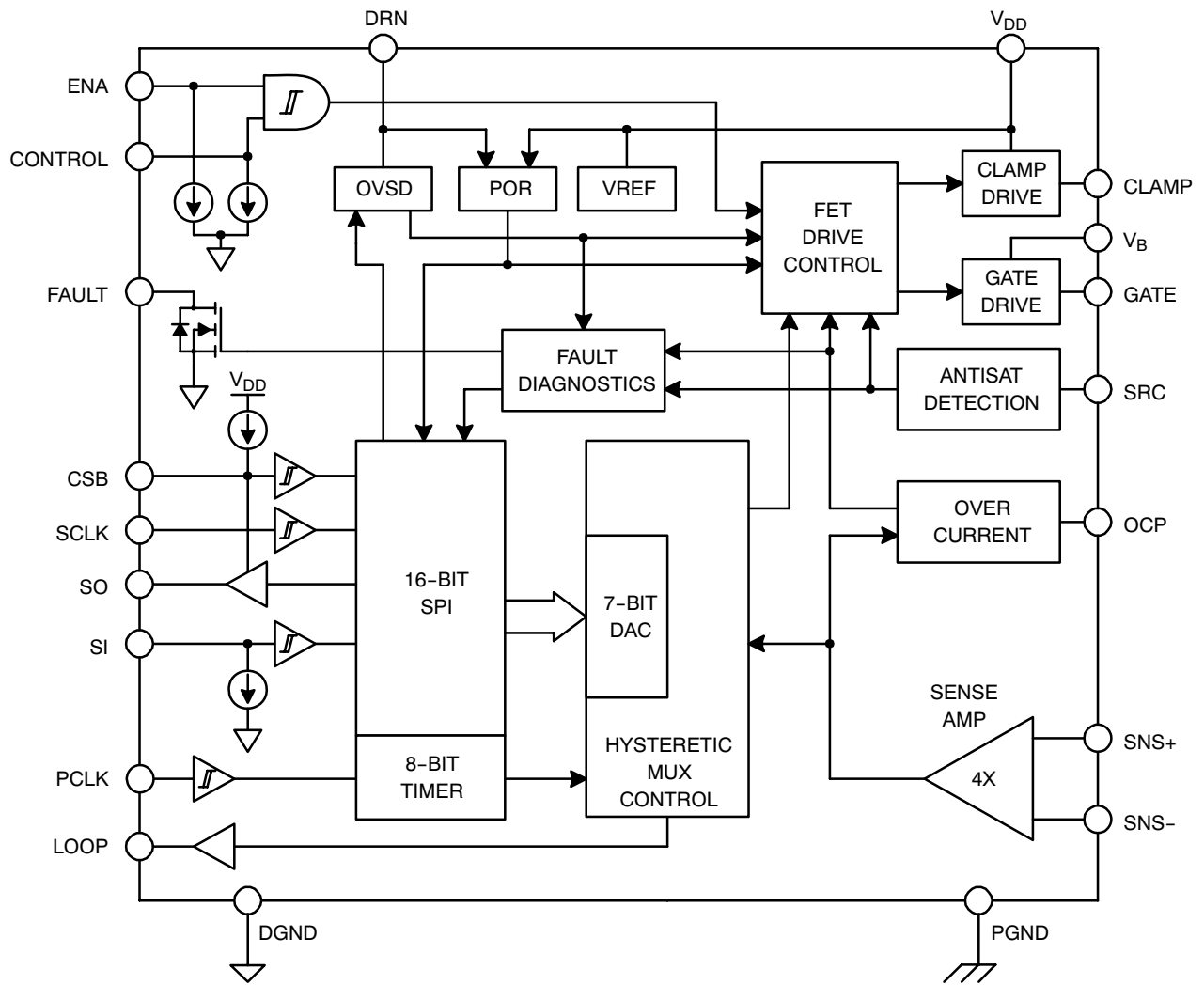
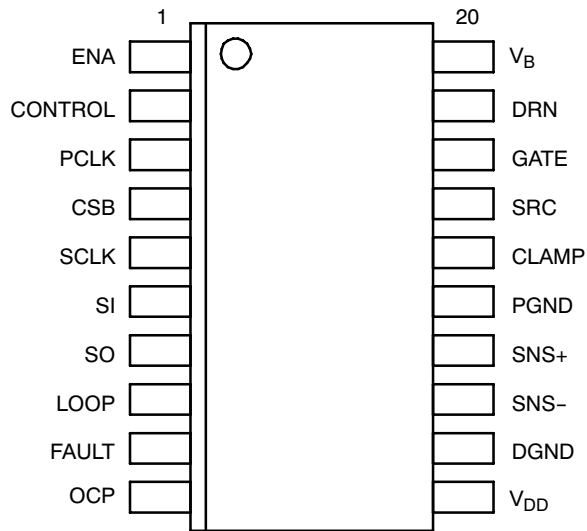

Figure 1. Block Diagram

NCV7510

PACKAGE PIN DESCRIPTIONS

PACKAGE PIN#	PIN SYMBOL	FUNCTION
1	ENA	Logic input for Enable.
2	CONTROL	Logic input for PWM cycle control.
3	PCLK	Logic input for clock or logic level control of Dwell timer.
4	CSB	Logic input for active low chip select.
5	SCLK	SPI clock input.
6	SI	SPI serial data input.
7	SO	SPI serial data output.
8	LOOP	Control loop state output.
9	FAULT	Open-drain fault output.
10	OCP	Overcurrent program input.
11	V _{DD}	Logic supply voltage input; CLAMP predriver voltage.
12	DGND	Supply return; device substrate.
13	SNS-	Current sense negative input.
14	SNS+	Current sense positive input.
15	PGND	High current supply return; CLAMP antisaturation reference node.
16	CLAMP	Clamp MOSFET gate drive output.
17	SRC	HS and CLAMP MOSFET antisaturation diagnostic input.
18	GATE	HS MOSFET gate drive output.
19	DRN	HS MOSFET drain antisaturation / overvoltage diagnostic input.
20	V _B	Bootstrapped GATE predriver voltage.



PIN FUNCTION DESCRIPTIONS

ENA: CMOS input with hysteresis logically ANDed with the CONTROL input to command the predriver outputs. This input has an active pulldown current source.

CONTROL: CMOS input with hysteresis logically ANDed with the ENA input to command the predriver outputs. This input has an active pulldown current source.

PCLK: Buffered CMOS input with hysteresis. This input controls which DAC register pair is selected for load current comparison. The input is programmed via Auxiliary register (\$01) bit D₃ to respond to a clock signal (AUX D₃=0 default at POR) or a logic level (AUX D₃=1.) The pin presents a 12 pF maximum load to the controller.

CSB: CMOS input with hysteresis. This input is the active-low chip select input that enables serial data transfer between the host controller and the device. This input has an active pullup current source.

SCLK: Buffered CMOS input with hysteresis. This input is the synchronizing clock input for serial data transfer between the micro controller and the device. The pin presents a 12 pF maximum load to the controller.

SI: Buffered CMOS input with hysteresis. This pin is the data input to the device's SPI shift register. Serial data received at this input is transferred from the host controller to the shift register under the control of the CSB and SCLK inputs. The pin presents a 12 pF maximum load to the controller. This input has an active pulldown current source.

SO: The CMOS compatible line driver at this pin is the data output from the device's SPI shift register. Serial data transmitted at this output is transferred from the shift register to the host controller under the control of the CSB and SCLK inputs. The pin is capable of driving 200 pF at 4 MHz and is HI-Z when the CSB input is high.

LOOP: The CMOS compatible driver at this pin reflects the state of the control loop. A logic low indicates that load current is less than the programmed DAC reference.

FAULT: An open-drain low voltage NMOS output at this pin provides immediate fault indication to a connected host controller. An external resistor is normally connected between this pin and V_{DD}.

DGND: Device substrate voltage and V_{DD} return path for mixed signal functions. This pin is the circuit common reference point.

OCP: This analog comparator input supplies a reference voltage to the device's overcurrent fault detection. When the voltage at this pin is less than 4.5 V, the applied voltage is the overcurrent reference voltage. When the voltage is greater than 4.5 V, an internal 3.0 V overcurrent reference is used. *The voltage at this pin must not exceed V_{DD}. Applying approximately V_{DD} + 1.4 V will place the NCV7510 in test mode and suspend normal operation. The user is advised to avoid activating the test mode.*

V_{DD}: +5.0 V power supply input. The voltage at this pin initiates power-on reset, supplies power to internal mixed-signal functions and supplies gate charge to the external CLAMP MOSFET. A low ESR external bulk capacitor connected between V_{DD} and PGND is recommended to supply transient gate charge. Several internal reference voltages are derived from V_{DD}.

SNS-: The inverting input to the analog current sense amplifier. This input should be Kelvin connected directly to the external current sense resistor's negative terminal.

SNS+: The noninverting input to the analog current sense amplifier. This input should be Kelvin connected directly to the external current sense resistor's positive terminal.

PGND: Return path for the GATE and CLAMP predriver transient currents and the lower input to the CLAMP antisaturation detection comparator. This pin should be star-connected to the CLAMP MOSFET's source and the external V_{DD} bulk charge capacitor's negative terminal.

CLAMP: External CLAMP MOSFET predrive output. This output switches the CLAMP MOSFET's gate between V_{DD} and PGND.

SRC: Lower input to the GATE antisaturation detection comparator and upper input to the CLAMP antisaturation detector.

GATE: External HS MOSFET predrive output. This output switches the HS MOSFET's gate between V_B and PGND.

DRN: Upper input to the GATE antisaturation detection comparator, overvoltage detection input, and powerup interlock input. This pin should be connected directly to the HS MOSFET's drain terminal.

VB: Bootstrap or boost input voltage. This input supplies gate charge to the external HS MOSFET.

NCV7510

MAXIMUM RATINGS (Voltages are with respect to device substrate.)

Rating	Symbol	Value	Unit
DC Supply Voltage (Note 1)	VDRN	-0.3 to 45	V
	V _{DD}	-0.3 to 7.0	V
VDRN Peak Transient Voltage (Note 2)	VDRN _(PK)	45	V
VB Pin Voltage	V _B	-2.0 to 50	V
GATE Pin Voltage	V _{GATE}	-2.0 to 50	V
VB to GATE Differential Voltage	V _B - V _{GATE}	50	V
SRC Pin Voltage	V _{SRC}	-2.0 to 45	V
Logic Level Input/Output Voltage (SO, SI, SCLK, CSB, ENA, CONTROL, PCLK, FAULT, LOOP)	V _{I/O}	-0.3 to 7.0	V
Sense Amplifier Input Voltage	V _{SNS+}	-0.3 to 45	V
	V _{SNS-}	-0.3 to 7.0	V
Overcurrent Comparator Input Voltage	V _{OCP}	-0.3 to 7.0	V
Junction Temperature	T _j	150	°C
Storage Temperature Range	T _{stg}	-65 to 150	°C
Peak Reflow Soldering Temperature: Lead-free (60 to 150 seconds at 217 °C)	(Note 3)	265 peak	°C

Stresses exceeding Maximum Ratings may damage the device. Maximum Ratings are stress ratings only. Functional operation above the Recommended Operating Conditions is not implied. Extended exposure to stresses above the Recommended Operating Conditions may affect device reliability.

1. Reverse VDRN protection must be included in the application circuit.
2. VDRN transient voltage suppression must be included in the application circuit.
3. For additional information, see or download ON Semiconductor's Soldering and Mounting Techniques Reference Manual, SOLDERRM/D, and Application Note AND8003/D.

ATTRIBUTES

Characteristic	Value	Unit
ESD Capability (All Pins)	> 3.0	kV
	> 1.0	kV
Moisture Sensitivity (Note 3)	MSL 1	
Package Thermal Resistance	55	°C/W
	9.0	°C/W

NCV7510

ELECTRICAL CHARACTERISTICS (5 V < V_{DRN} < 26 V, 4.75 V < V_{DD} < 5.25 V, -40°C < T_J < 125°C, unless otherwise specified.)
(Note 4)

Characteristic	Conditions	Min	Typ	Max	Unit
----------------	------------	-----	-----	-----	------

DRN Input

Input Current	V _{DRN} = 12.8 V, V _{DD} = 0 V	–	–	5.0	μA
	V _{DRN} = 26 V, V _{DD} = 5.25 V	–	0.5	2.0	mA
Power-On Lockout Threshold	V _{DD} = 0 V, GATE predriver locked out	–	0.7	1.5	V
Over-Voltage Lockout	GATE predriver disabled, CLAMP predriver active Auxiliary Register Bit 6 = 1	28	32	36	V
Over-Voltage Hysteresis		0.1	0.8	2.0	V

V_B Input

Input Bias Current	V _B = 24 V	–	0.7	1.5	mA
--------------------	-----------------------	---	-----	-----	----

V_{DD} Supply

Operating Current	V _{DRN} = 14 V		3.5	7.0	mA
Power-On Reset Threshold	Predrivers disabled, V _{DD} rising	3.0	3.5	4.4	V
Power-On Reset Hysteresis		–	0.25	–	V

Digital I/O

V _{IN} High	ENA, CONTROL, SI, SCLK, CSB, PCLK	2.2	–	–	V
V _{IN} Low	ENA, CONTROL, SI, SCLK, CSB, PCLK	–	–	0.8	V
V _{IN} Hysteresis	ENA, CONTROL, SI, SCLK, CSB, PCLK		0.6	1.2	V
Input Pulldown Current	ENA, CONTROL, SI: V _{IN} = V _{DD}	–	–	25	μA
Input Pullup Current	CSB: V _{IN} = 0 V	-25	–	–	μA
SO Low Voltage	I _{SINK} = 1 mA	–	–	0.4	V
SO High Voltage	I _{SOURCE} = 1 mA	V _{DD} - 1.0	–	–	V
LOOP Low Voltage	I _{SINK} = 0.1 mA	–	–	0.5	V
LOOP High Voltage	I _{SOURCE} = 0.1 mA	V _{DD} - 1.0	–	–	V
LOOP Output Response Delay (See Figure 3)	t _{LOOP(HL)} ; C _{LOOP} = 50 pF	–	0.5	1.2	μs
	t _{LOOP(LH)} ; C _{LOOP} = 50 pF	–	0.5	1.2	μs
FAULT Low Voltage	FAULT Active, I _{FAULT} = 0.5 mA	–	0.1	0.5	V

PCLK Input

Input Capacitance	(Note 5)	–	–	12	pF
Clock Frequency	Auxiliary Register Bit 3 = 0 (Note 5)	0	–	20	MHz
DAC Reference Select Delay	Auxiliary Register Bit 3 = 1 (Note 5)	–	–	3.0	μs

NCV7510

ELECTRICAL CHARACTERISTICS (continued) (5 V < VDRN < 26 V, 4.75 V < VDD < 5.25 V, -40°C < TJ < 125°C, unless otherwise specified.) (Note 4)

Characteristic	Conditions	Min	Typ	Max	Unit
GATE and CLAMP Predrivers					
GATE Output R _{DS(ON)} High	V _B = 7.3 V, V _B -V _{GATE} = 0.5 V	–	20	50	Ω
GATE Output R _{DS(ON)} Low	V _B = 7.3 V, V _{GATE} = 0.5 V	–	20	50	Ω
GATE Output Delay (See Figure 4)	t _{P(LH)} ; ENA or CONTROL High to GATE High C _{GATE} =2 nF	–	0.8	1.6	μs
	t _{P(HL)} ; ENA or CONTROL Low to GATE Low C _{GATE} =2 nF	–	0.3	0.6	μs
GATE Response Delay (See Figure 4)	t _{DLY(GR)} ; SNS+ Falling to GATE Rising V _{DD} =5.0 V, VDRN=10 V, V _B =20 V, V _{SRC} Following V _{GATE} , V _{DAC} =20% FS, C _{GATE} =2 nF	–	0.4	1.6	μs
	t _{DLY(GF)} ; SNS+ Rising to GATE Falling V _{DD} =5.0 V, VDRN=10 V, V _B =20 V, V _{SRC} Following V _{GATE} , V _{DAC} =80% FS, C _{GATE} =2 nF	–	0.4	1.6	μs
GATE Output Low Hold Time (See Figure 5)	V _{DD} = 5.0 V, C _{GATE} =2 nF	5.0	10	15	μs
GATE Output Pulldown	(HI-Z)	20	60	150	kΩ
CLAMP Output R _{DS(ON)} High	V _{DD} = 5.0 V, V _{DD} -V _{CLAMP} = 0.5 V	–	20	50	Ω
CLAMP Output R _{DS(ON)} Low	V _{DD} = 5.0 V, V _{CLAMP} = 0.5 V	–	20	50	Ω
CLAMP Output Pulldown		50	200	500	kΩ
CLAMP Output Delay	ENA or CONTROL Input Low to CLAMP Output Low; (Note 5)	–	–	3.0	μs

Current Sense Amplifier

Input Bias current	SNS+, SNS- = 0 V (Each Input)	-5.0	-	-	μA
Input Common Mode Range	ΔV(SNS+, SNS-) = 750 mV	-0.3	-	1.0	V

Current Sense Conversion (V_{DD} = 5.0 V)

D/A Resolution	Referred to SNS+, SNS- Inputs	4.70	4.92	5.20	mV
Full Scale Value	Referred to SNS+, SNS- Inputs	575	625	675	mV
Differential Non-Linearity		–	–	±0.75	LSB
DAC Offset	DAC Code = 0	-5.0	-	5.0	mV
Trip Point Accuracy	DAC Code = 32 ₁₀ (25% FS)	-12.5	-	12.5	mV
	DAC Code = 66 ₁₀ (50% FS)	-12.5	-	12.5	mV
	DAC Code = 95 ₁₀ (75% FS)	-12.5	-	12.5	mV
DAC Response Delay (See Figure 6)	t _{DAC} ; CSB Rising to LOOP State Change DAC Code = 127 ₁₀ (Full Scale) C _{GATE} = 2 nF (Note 5)	–	-	500	ns

NCV7510

ELECTRICAL CHARACTERISTICS (continued) (5 V < VDRN < 26 V, 4.75 V < V_{DD} < 5.25 V, -40°C < T_J < 125°C, unless otherwise specified.) (Note 4)

Characteristic	Conditions	Min	Typ	Max	Unit
Overcurrent Comparator					
Input Bias Current	V _{OCP} = 3.0 V	–	0.26	3.0	μA
Linear Input Voltage Range		1.0	–	3.0	V
Mode Select Threshold	V _{DD} = 5.0 V	4.2	4.5	4.8	V
Internal Overcurrent Reference	V _{OCP} = V _{DD} = 5.0 V	2.7	3.0	3.3	V
Detection Blanking Time (See Figure 7)	Time to FAULT output low	1.25	2.5	5.0	μs
Antisaturation Detect					
GATE MOSFET	Auxiliary Register Bit 5 = 0, VDRN–V _{SRC}	0.96	1.20	1.44	V
	Auxiliary Register Bit 5 = 1, VDRN–V _{SRC}	1.92	2.40	2.88	V
CLAMP MOSFET	Auxiliary Register Bit 4 = 0, V _{SRC} –V _{PGND}	0.2	0.4	0.6	V
	Auxiliary Register Bit 4 = 1, V _{SRC} –V _{PGND}	0.4	0.8	1.2	V
SRC Input Bias Current	V _{SRC} = 14 V, V _{GATE} = 14 V	–	0.44	4.0	μA
	V _{SRC} = 0 V, V _{GATE} = 0 V	-10	–	–	μA
Detection Blanking Time (See Figure 8)	Time to FAULT output low; GATE or CLAMP	5.0	10	20	μs
Serial Peripheral Interface (VDRN = 14 V, V _{DD} = 5.0 V, C _{SO} = 200 pF) (Figure 9)					
SCLK Clock Period		250	–	–	ns
Maximum Input Capacitance	SI, SCLK; (Note 5)	–	–	12	pF
SCLK High Time	f _{sclk} = 4.0 MHz, SCLK = 2.0 V to 2.0 V	125	–	–	ns
SCLK Low Time	f _{sclk} = 4.0 MHz. SCLK = 0.8 V to 0.8 V	125	–	–	ns
SI Setup Time	SI = 0.8 V/2.0 V to SCLK = 2.0 V f _{SCLK} = 4.0 MHz (Note 5)	25	–	–	ns
SI Hold Time	SCLK = 2.0 V to SI = 0.8 V/2.0 V f _{SCLK} = 4.0 MHz (Note 5)	25	–	–	ns
SO Rise Time	(10% V _{SO} to 90% V _{DD}) C _{SO} = 200 pF (Note 5)	–	25	50	ns
SO Fall Time	(90% V _{SO} to 10% V _{DD}) C _{SO} = 200 pF (Note 5)	–	–	50	ns
CSB Setup Time	CSB = 0.8 V to SCLK = 2.0 V (Note 5)	60	–	–	ns
CSB Hold Time	SCLK = 0.8 V to CSB = 2.0 V (Note 5)	75	–	–	ns
SO Delay Time	SCLK = 0.8 V to SO Data Valid f _{SCLK} = 4.0 MHz (Note 5)	–	65	125	ns
Transfer Delay Time	CSB rising edge to next falling edge. (Note 5)	1.0	–	–	μs

4. Designed to meet these characteristics over the stated voltage and temperature recommended operating ranges, though may not be 100% parametrically tested in production.
5. Guaranteed by design.

NCV7510

TIMING WAVEFORMS

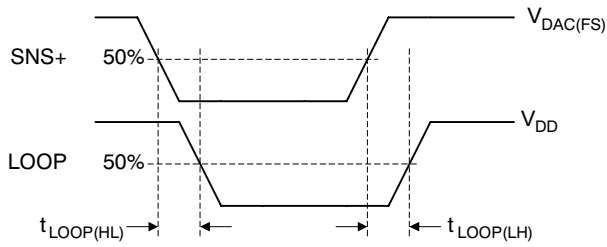

Figure 3. LOOP Output Response Delay

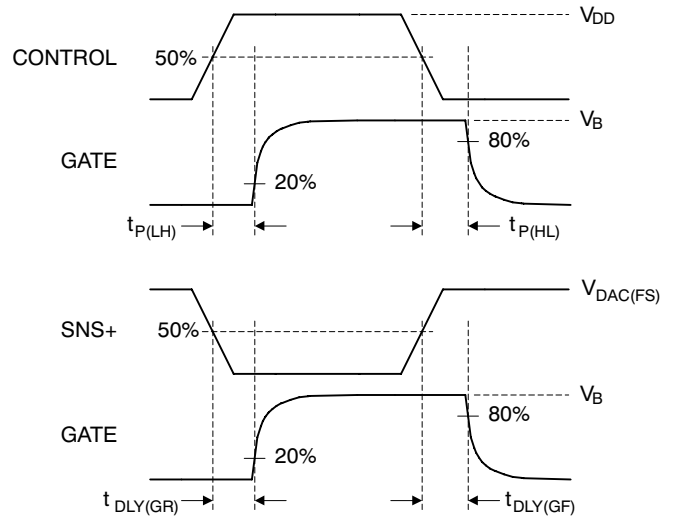

Figure 4. Gate Output Delay

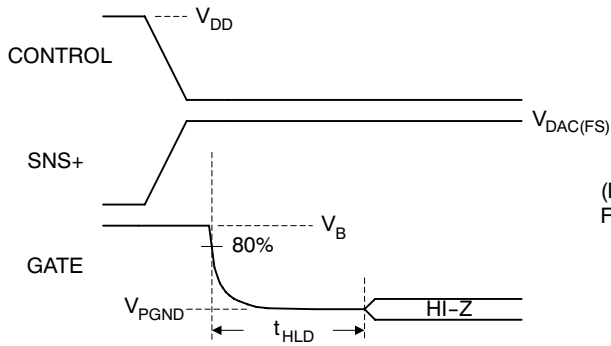

Figure 5. Gate Output Low Hold Time
(Gate Switched by CONTROL or SNS+)

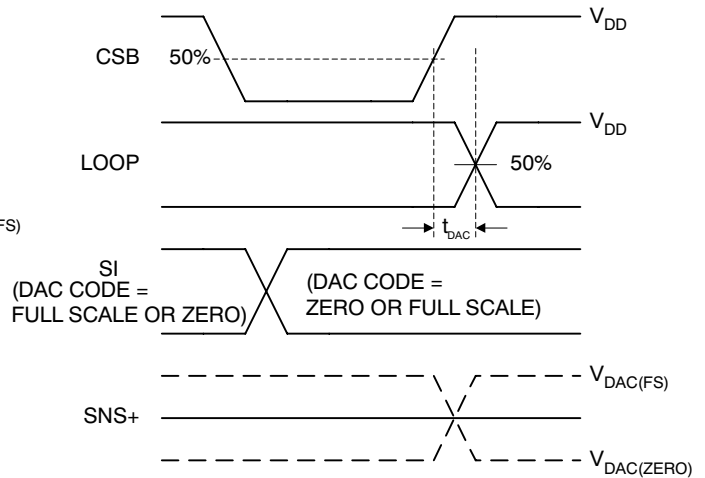

Figure 6. DAC Response Delay

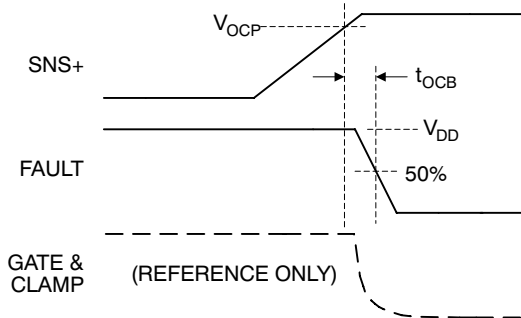

Figure 7. Overcurrent Detection Blanking Time

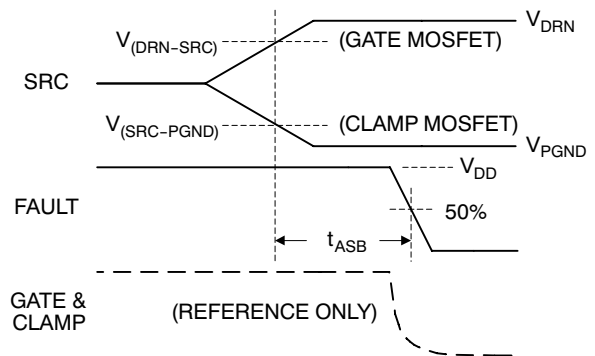
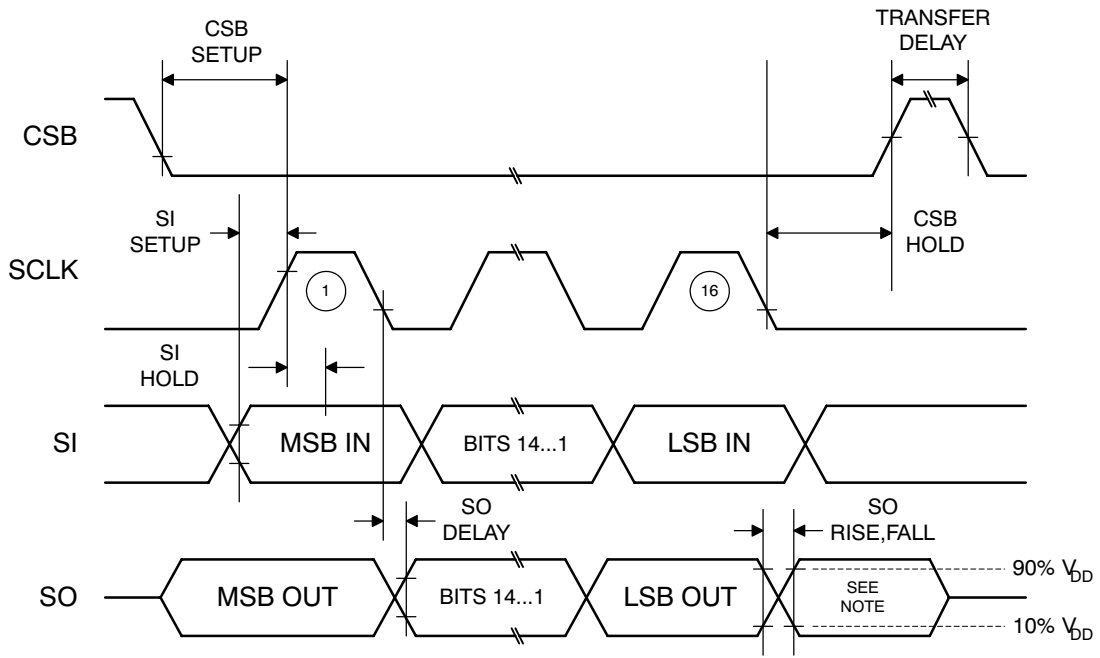

Figure 8. Antisaturation Detection Blanking Time

NCV7510



Note: Not defined but usually MSB of data just received.

Figure 9. SPI Timing

BASIC OPERATING DESCRIPTION

Introduction

The NCV7510 is designed for use as a predriver for solenoids or other inductive loads requiring a “peak and hold” function. It contains all the necessary circuitry for programming various attributes of the peak and hold events. These attributes include the current levels of the peak (or pull-in) event, the current levels of the hold event and the dwell time of the pull-in event (See Figure 10 Waveforms). The attribute values are written into appropriate registers in the NCV7510 via a 16-bit SPI interface. The peak and hold event is directly initiated and determined by the inputs to the ENA and CONTROL pins. By applying a logic high level to these inputs, the user has precise control over how long the solenoid will be activated.

The dwell time base for the pull-in event is provided to the IC’s PCLK input by the user, and may be programmed by a register bit to either be derived from a clock signal or be level controlled. When driven by a clock signal, the drive mode will automatically change from the peak to the hold event when the dwell time expires. When level controlled, the drive mode will change according to the logic state of the PCLK input. Bringing the ENA or CONTROL input low before the dwell time expires will terminate the peak event and turn off the predrivers. Figure 10 shows the general behavior of the NCV7510.

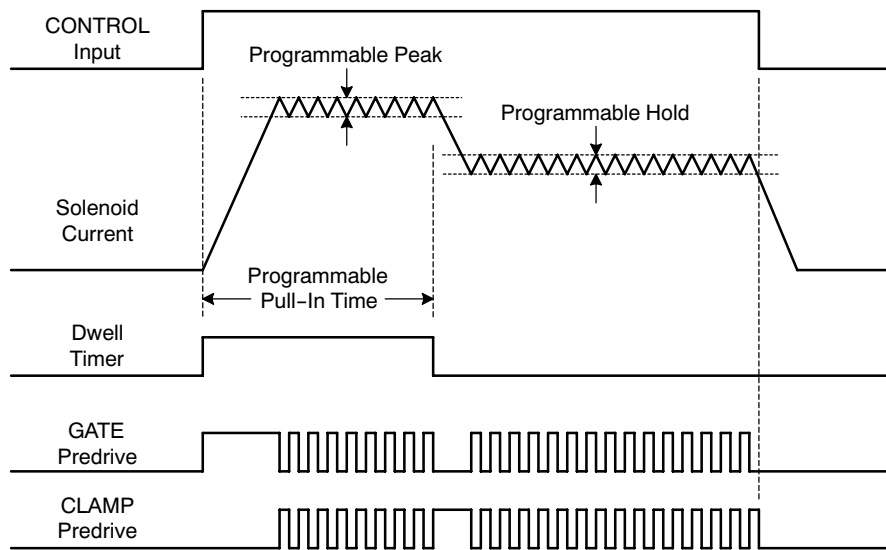

Figure 10. Idealized Waveforms

BASIC OPERATING DESCRIPTION (continued)

Hysteretic Control

The NCV7510 employs hysteretic control to achieve the programmed peak and hold currents. The IC measures the load current via an external sense resistor (See Functional Block Diagram on page 2 and Application Diagram on page 3). This voltage is applied to a differential amplifier's SNS+ and SNS- inputs. The amplified signal is then compared to the programmed peak and hold reference levels generated from the 7-bit D/A converter. (Refer to Figure 11)

During the peak event, the load current is compared to the programmed values in the peak high and peak low registers for the duration of the programmed dwell time. The hysteretic controller will switch between the programmed peak high and peak low values at a PWM rate determined by the load supply voltage, the load characteristics, the peak and valley current levels, and the response times of the NCV7510 and external MOSFETs. When the dwell time has been reached, the controller will select the programmed values in the hold high and hold low registers and the load current will then be compared to these values. The hysteretic PWM rate for the hold event is dependent on the same factors as the peak event.

When the ENA and CONTROL inputs are brought high, the dwell timer is initialized and the MOSFET drive control circuit selects the GATE predrive output, activating the high side MOSFET and allowing current to increase in the load. When the peak high current level is reached, the MOSFET drive control circuit will turn off the GATE predrive and then turn on the CLAMP predrive. With the high side MOSFET turned off, current in the load will begin to decrease. When the peak low current level is reached, the MOSFET drive control circuit will turn off the CLAMP predrive and then turn on the GATE predrive. The peak event may be terminated before the end of the programmed dwell time by bringing either the ENA or CONTROL input low. Otherwise, the peak high/low cycle repeats for the duration of the peak dwell time.

Once the peak dwell time has been reached, the hysteretic MUX control circuit will switch from the peak high and peak low registers and now use the hold high and hold low registers. Operation in this mode is quite the same as described above for the peak event, except that the programmed hold currents are now used to reduce power dissipation in the load. The complete peak and hold event is terminated when ENA or CONTROL is brought low.

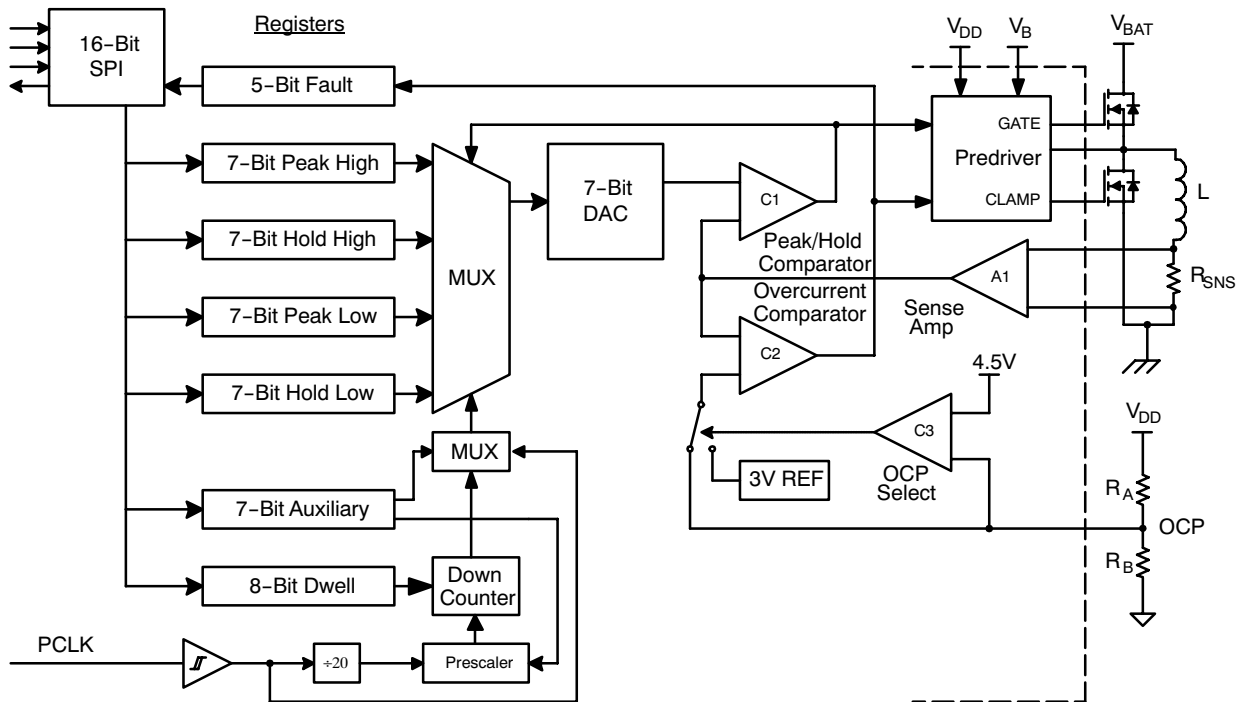

Figure 11. Hysteretic MUX Control Block Diagram

DETAILED OPERATING DESCRIPTION

Power Up/Down Control

The NCV7510 powerup control prevents spurious output operation by interlocking the V_{BAT} and V_{DD} power supplies. At the system level, it is assumed that the V_{BAT} voltage is available before the V_{DD} voltage. The Power-On Reset (POR) interlock circuit derives an output disable signal from the V_{BAT} voltage at the DRN input and causes the GATE and CLAMP outputs to be kept at the PGND potential. Application of the V_{DD} power supply allows the outputs to subsequently be enabled when the V_{DD} voltage exceeds the POR threshold. All internal registers are then initialized to their default states, fault data is cleared and the GATE and CLAMP outputs are held low (external MOSFET V_{GS} approximately 0 V.) When the V_{DD} voltage falls below the POR threshold during power down, the GATE and CLAMP outputs are driven and held low until V_{BAT} falls below about 1.2 volts.

SPI Communication

The NCV7510 is a 16-bit SPI slave device. Fault data is simultaneously sent from the device’s SO pin while command data is received at the SI pin under synchronous control of the master’s SCLK signal. No parity or buffer under/over run detection circuitry is employed; therefore a valid CSB frame must contain exactly 16 SCLK cycles for each CSB high–low–high transition.

The host initiates communication when the CSB input is driven low. Present fault data is latched in the device’s SPI shift register when CSB goes low. Fault data, sent MSB first at the SO output, changes on the falling edge of SCLK and is guaranteed valid before the next rising edge of SCLK. The data at the SI input is received MSB first and must be valid before the rising edge of SCLK. The 16 bits received at the SI input before CSB is driven high will be translated as the current command.

SPI communication between the host and the NCV7510 may either be parallel via individual CSB addressing or daisy-chained through other devices using a compatible SPI protocol.

Command and Register Structure

The 16-bit command data received by the NCV7510 is decoded into 8-bit address and 8-bit data words. The upper byte, beginning with the received MSB, is bit-wise decoded to address one of six internal registers and the lower byte is decoded into program data for the addressed register. A dummy address (\$00) can also be sent to retrieve fault data. Note that the register addresses are not fully decoded.

Sending an address combining more than one address bit will result in the same data being sent to more than one register. Bits A₇ and A₆ select internal test modes and should always be set to 0. Figure 12 describes the general 16-bit SPI word format and valid register addresses. Each register is next described in detail.

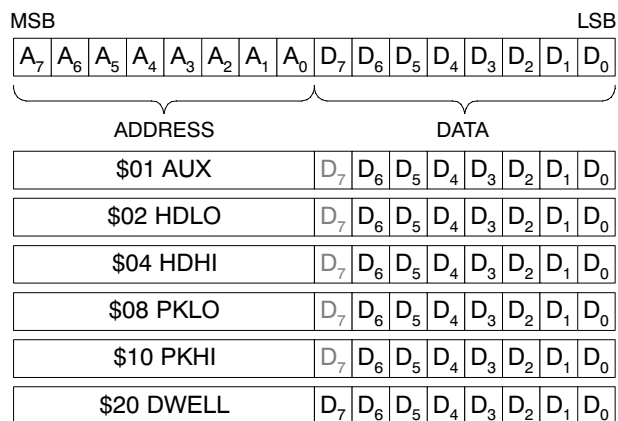

Figure 12. 16-bit SPI Word Format and Valid Register Addresses

Auxiliary Register [\$01]

The AUX register is used to program several diagnostic features and the behavior of the dwell timer under control of the PCLK input and the DWELL timer register. This register is initialized to \$00 at POR. Bit definitions are shown for this register in Figure 13.

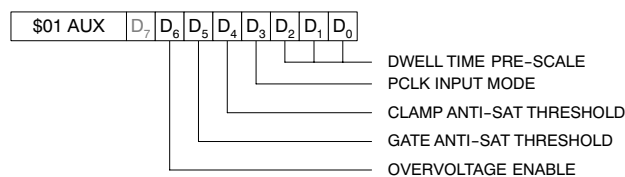

Figure 13. AUX Register Bit Definitions

Bit D₇ selects an internal test mode and should always be set to 0. Bit D₆ controls interruption of load current by the overvoltage detection function. At POR, the overvoltage interrupt function is disabled. Programming D₆=1 enables overvoltage interrupt and will cause the FAULT output to respond to an overvoltage event. Overvoltage events are reported via the SPI shift register regardless of the state of AUX D₆.

DETAILED OPERATING DESCRIPTION (continued)

Bits D₄-D₀ of the 16-bit SO word indicate detected faults such that D_X = 1 when a fault is detected. Figure 16 describes the fault bit definitions. At POR, the register bits are cleared to \$00. Refer to the Fault Diagnosis description for details regarding the NCV7510's fault strategies and behaviors, discussed in the next section.

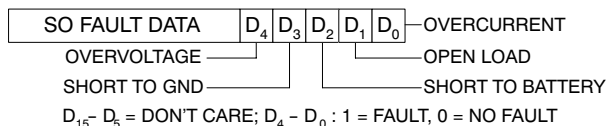

Figure 16. SO Fault Bit Definitions

Fault Diagnosis and Protection Behavior

General

The NCV7510 continuously monitors the load supply voltage, external MOSFETs, the load current, and the control loop state during a control cycle for fault conditions. Faults are managed on a cycle-by-cycle basis with regard to the CONTROL and ENA inputs and are recoverable (automatic fault re-try) such that the NCV7510 will attempt to properly drive the load during the next control cycle. Attention is focused on faults that may cause destructive failure of the load, the external MOSFETs, or the sense resistor.

Overcurrent faults are detectable regardless of the CONTROL and ENA input states. Short to battery and short to GND (antisaturation) faults are detectable when the CONTROL and ENA inputs are high. Destructive fault types are managed when possible to prevent failure by latching both predriver outputs off. Fault reporting for these types is priority encoded such that the first detected fault locks out subsequent fault reporting bits. These faults cause the FAULT flag to be set and latched low.

Non-destructive open load faults require no intervention and are detectable at the end of a control cycle when CONTROL or ENA goes low. This fault type has no priority and is reported if no other fault has been detected, and does not set the FAULT flag.

Overvoltage faults are detected without regard to the CONTROL and ENA inputs. Management, reporting and FAULT flag behavior for this fault type is dependent upon the state of AUX register bit D₆.

Reset of fault protection, and clearing of fault data and the FAULT flag are independent. Protection circuitry is reset on the rising edge of either the CONTROL or ENA inputs. Fault data and the FAULT flag are cleared by the rising edge of CSB. At power-on reset, all fault protection, fault data, and the FAULT flag are cleared.

Fault detection, protection and reporting are detailed in the following sections and are summarized in Table 1.

Overvoltage

The load supply voltage is monitored at the DRN pin for overvoltage faults, and fault detection occurs regardless of the states of CONTROL and ENA inputs. The interruption of load current by the overvoltage detection circuit can be programmed by bit D₆ in the AUX register. At POR, the overvoltage interrupt default state is disabled (AUX D₆=0).

When AUX D₆=0 an overvoltage fault has no priority and is reported if no other fault has been detected. The predrivers and the FAULT flag are unaffected.

Programming AUX D₆=1 enables overvoltage interrupt. When CONTROL and ENA are high, an overvoltage fault will cause the GATE output to be latched off, the CLAMP output to be latched on, and the FAULT flag to be latched low. The fault is given reporting priority and locks out subsequent fault reporting bits. Overvoltage protection is reset when CONTROL or ENA is brought low and then high again.

Avalanche of the high side (HS) MOSFET may occur when the CLAMP MOSFET is on during an overvoltage fault (overvoltage enabled.) Avalanche of both the HS and CLAMP MOSFETs may occur (overvoltage disabled) if the overvoltage amplitude exceeds the combined avalanche voltages of both MOSFETs. The devices should be carefully chosen for proper avalanche voltage and avalanche energy rating suitable to the application and its operating environment.

Note that the NCV7510 requires transient overvoltage suppression in accordance with the specifications in the Maximum Ratings table.

Overcurrent

Load current (converted to a voltage by external sense resistor R_{SNS}) is monitored at the SNS+ and SNS- differential inputs. A fault is detected when the amplified differential voltage exceeds the overcurrent reference. A nominal 2.5 μs filter is used to help prevent false overcurrent detection.

Overcurrent detection occurs regardless of the states of the CONTROL and ENA inputs. This fault has reporting priority and will latch the FAULT flag low. If overcurrent is detected when CONTROL and ENA are high, both GATE and CLAMP outputs are latched off. Overcurrent protection is reset when the CONTROL or ENA input is brought low and then high again.

DETAILED OPERATING DESCRIPTION (continued)

An overcurrent comparator input pin (OCP) is provided to program a current limit reference value. When the voltage at the OCP input is less than 4.5 V, the applied voltage is the overcurrent reference voltage. When the voltage is greater than 4.5 V, an internal 3.0 V overcurrent reference is used.

The voltage at OCP pin must not exceed V_{DD}. Applying approximately V_{DD} + 1.4 V will place the NCV7510 in test mode and suspend normal operation. The user is advised to avoid activating the test mode.

The OCP reference can be programmed via an external voltage divider placed between the V_{DD} and DGND pins, as illustrated by resistors R_A and R_B in the Hysteretic MUX Block and Application diagrams. The following formulas can be used to dimension the resistors:

$$R_A = R_B \left(\frac{V_{DD}}{I_{OC} \times 4 \times R_{SNS}} - 1 \right) \quad (\text{eq. 4})$$

$$I_{OC} = \left(\frac{R_B}{R_A + R_B} \right) \left(\frac{V_{DD}}{4 \times R_{SNS}} \right) \quad (\text{eq. 5})$$

where 4 is the nominal sense amplifier gain and R_{SNS} is the external load current sense resistor.

Overcurrent faults may be detected when the load is shorted, when the SNS+ input is shorted to V_{BAT}, when the sense resistor is open, or when the peak or hold currents are programmed higher than the overcurrent reference.

Open-circuit failure of the sense resistor may produce voltages in excess of the NCV7510's SNS+ input Maximum Rating. This condition can be avoided by series connection of a pair of diodes across the sense resistor (see Application Diagram – D5, D6) to provide a path for the load current. The diodes must be capable of carrying the maximum expected load current and should be energy-rated for the application.

Open Load

To maintain the scalable flexibility of the NCV7510, the states of the CLAMP predriver output and the ENA and CONTROL inputs are monitored to determine an open load condition as opposed to the detection of an absolute value of minimum load current. It is expected that during normal operation, a state change will occur at the CLAMP output as a result of load current modulation between the peak high and peak low program points while ENA and CONTROL are high. Open load detection relies on the occurrence of a control loop state change before the ENA or CONTROL input goes low.

If a control loop state change has not occurred during the time that ENA and CONTROL were high, an open load fault is detected. When an open load fault is detected, no intervention is required. This fault type has no priority and is reported if no other fault has been detected, and does not set the FAULT flag. Open load fault data is cleared by the rising edge of CSB.

Open load faults may be detected when the load is open, when the sense resistor is shorted, or when the load current is unable to reach the programmed peak or hold high current value.

False open load faults may be indicated during engine cranking when battery voltage can initially dip to about 5–6 volts. The programmed current may not be reached and a state change in the control loop may not occur, thus producing a false open load indication.

Antisaturation

Each of the high side and clamp MOSFET's drain-to-source voltages is separately monitored and compared to an independently programmable saturation detection threshold voltage. The detection thresholds are programmed via the AUX D₅ and D₄ register bits. At POR, the thresholds default nominally to 1.2 V for the high side MOSFET and to 0.4 V for the clamp MOSFET. Setting AUX D₅=1 programs the high side antisaturation detection threshold to nominally 2.4 V. Similarly, setting AUX D₄=1 programs the clamp antisaturation detection threshold to nominally 0.8 V. Each of the antisaturation detectors employs a nominal 10 μs filter to help prevent false anti-sat fault detection.

When CONTROL and ENA are high, the antisaturation circuitry monitors the voltage between the DRN and SRC pins (high side) if the GATE output is on and monitors the voltage between the SRC and PGND pins if the CLAMP output is on.

High side saturation may be detected when a short to ground fault at the SRC pin exists. Clamp saturation may be detected when a short to battery fault at the SRC pin exists. The GATE and CLAMP outputs are latched off and the FAULT flag is set if either of these faults is detected.

Fault reporting for these types is priority encoded such that the first detected fault locks out subsequent fault reporting bits. Antisaturation protection is reset when the CONTROL or ENA input is brought low and then high again.

NCV7510

DETAILED OPERATING DESCRIPTION (continued)

Table 1. Fault Types, Management and Reporting

Fault Type	Input States			†Output States		‡Fault Data		‡FAULT Flag Set	Note
	CONTROL	ENA	AUX D ₆	GATE	CLAMP	Report Bit	Priority		
Overcurrent	X	X	X	OFF	OFF	D0	YES	YES	
Open Load	H→L	1	X	OFF	OFF	D1	NO	NO	1
Short to BAT	1	1	X	OFF	OFF	D2	YES	YES	2
Short to GND	1	1	X	OFF	OFF	D3	YES	YES	3
Overvoltage	X	X	0	—	—	D4	NO	NO	4
	0	1	1	OFF	OFF		YES	YES	
	1	1	1	OFF	ON		YES	YES	

†Output states after detection of a fault. Protection is reset on the rising edge of the CONTROL or ENA inputs.

‡ Fault data and the flag are cleared by the rising edge of the CSB input.

1. If detected, fault is reported after the falling edge of the CONTROL (or ENA) input.

2. Detection via CLAMP antisaturation.

3. Detection via GATE antisaturation.

4. When AUX D₆ = 0, overvoltage will be reported along with priority faults; outputs are unchanged.

DETAILED OPERATING DESCRIPTION (continued)

Operational Behavior**General**

The NCV7510 is designed to maintain the programmed load current at the PKHI and PKLO or at the HDHI and HDLO reference values. While the device's flexibility allows all of these to be programmed to the same value, a non-zero value is nonetheless required and the minimum value is constrained by the NCV7510's DC and AC capabilities. It is also possible to reverse the order of the PKHI|PKLO and HDHI|HDLO register values such that the HI value is less than the LO value. While this is unlikely to result in damage to the application, it will certainly lead to bizarre behavior.

As previously noted, the PKHI program value may not be reached during engine cranking when battery voltage may initially dip to about 5-6 volts, particularly when driving low resistance loads. This has additional implications for both the external bootstrap circuitry (duty cycle \neq 100%) and open-load detection behavior, both of which are discussed in other sections of this data sheet.

The NCV7510's ability to maintain the programmed load currents is constrained by the *total* of the NCV7510's inherent DC accuracy and loop response delay, the load characteristics, and any additional delays imposed by external compensation circuitry, whether slew-rate limiting or other filtering designed to attenuate the egress or ingress of radiated or conducted EMI.

Mode Control

The dwell timer selects which pair of the peak or hold registers is setting the internal DAC and thus determines whether the device is operating in the peak mode or the hold mode. Bit D₃ of the AUX register determines whether a logic level at the PCLK input directly controls the dwell time or whether the internal dwell timer divides down an external clock signal at the PCLK input.

When AUX D₃=1, the control loop will be placed in the peak mode when PCLK=0 and in the hold mode when PCLK=1. When AUX D₃=0, the control loop state will be determined by the state of the dwell timer. The dwell time is programmed via prescale divisor AUX register bits D₂-D₀ and by the 8-bit DWELL timer register.

In the following sections, "dwell timer" means either the state of the logic level at the PCLK input or the state of the internal dwell timer.

Output Control

The state of the GATE and CLAMP outputs is determined by the ENA and CONTROL inputs and by the state of the control loop. In the absence of any faults, the state of the control loop is determined by the contents of the peak and hold registers, the state of the dwell timer, and the magnitude of the load current.

The output control cycle begins when both the ENA and CONTROL logic inputs are asserted high and ends when either input is asserted low. At the beginning of each control cycle the dwell timer and protection circuitry are initialized, and the internal DAC is initialized to the PKHI register value (if the dwell time register content is non-zero or if AUX D₃=1 and PCLK=0) or to the HDHI register value (if the dwell time register content is null or if AUX D₃=1 and PCLK=1). The GATE and CLAMP output states will be determined by the state of the control loop. At the end of each control cycle the GATE and CLAMP outputs are driven low, the dwell timer is reset, and open load fault data is transferred into the SPI shift register if an open load fault exists.

Control Loop

Load current is converted to a voltage via an external sense resistor and compared with the programmed internal DAC voltages. During the dwell time, the load current is compared to the DAC voltages set by the peak high and peak low register values. When the dwell time expires, the load current is compared to the DAC voltages set by the hold high and hold low register values. The state of the control loop is reflected at the LOOP output such that a logic low indicates that load current is less than the programmed DAC reference.

When the load current is less than the peak or hold high current, the GATE output is at the V_B potential and the CLAMP output is at PGND. When the load current is greater than the peak or hold HI current, the DAC voltage is set to the peak or hold LOW register value, the GATE output is driven to PGND and the CLAMP output is driven to V_{DD}. When the load current is less than the peak or hold low current, the DAC voltage is set to the peak or hold HIGH register value, the GATE output is driven to V_B and the CLAMP output is driven to PGND.

DETAILED OPERATING DESCRIPTION (continued)

MOSFET Predrivers

The NCV7510 employs cross-conduction suppression for the external high side and clamp MOSFETs. The CLAMP antisaturation circuitry is used to detect the turn-off of the high side MOSFET and the voltage at the CLAMP pin is monitored to detect turn-off of the CLAMP MOSFET. Figure 17 shows the simplified predriver circuits.

The high side predriver is designed to allow external system level diagnostics to be implemented at the SRC pin. The driver is constructed to provide a typical 20 Ω discharge path for 10 μs at turn-off and a 60 kΩ gate-source bleed resistance to help prevent MOSFET turn-on from leakage or noise. The R_G resistor must be carefully chosen to ensure full depletion of the high side MOSFET's gate charge in less than 10 μs.

Current for the GATE predrive output is supplied from the V_B voltage developed by an external bootstrap circuit or boost power supply. Current for the CLAMP predrive output is supplied from the V_{DD} power supply.

While the IC contains no slew rate control circuitry, slew rate control of the high side MOSFET can be achieved by the use of a series gate resistor (R_G.) Since the body diode of the CLAMP MOSFET conducts the load current immediately after high side turn off, slew rate control of the CLAMP MOSFET gives no benefit and the use of a series gate resistor will interfere with cross-conduction suppression.

Bootstrap Circuit

A bootstrap circuit can be constructed using a diode, resistor, and capacitor to generate the V_B voltage necessary to put the external high side MOSFET in full conduction (refer to Figure 17). The circuit charges C_{BOOT} through D2 and R_{LIM} when the SRC pin is low. The charge is then transferred to the high side MOSFET when M1 in the GATE predriver is turned on, and the capacitor rides up with the voltage at the SRC pin. The charge is continually refreshed as a result of alternate switching of the high side and clamp MOSFETs. A clamp diode at the V_B input (see Application Diagram – Diode D3) may be needed to keep the NCV7510 within its maximum ratings during overvoltage transients. D4 ensures that the high side MOSFET's maximum V_{GS} is not exceeded (refer to Figure 17).

While simple and straightforward in operation, a bootstrap circuit depends on periodic refresh and thus cannot run at 100% duty cycle. During engine cranking, the PKHI program value may not be reached and a state change in the control loop may not occur, possibly fully depleting (and preventing recharge) of the bootstrap capacitor.

With the use of logic-level MOSFETs and careful design, sufficient V_{GS} should be available during start up. Attention to leakage paths (such as external gate-source bleed resistors) and the V_B input bias current will help ensure that gate charge is available when recharge does not occur.

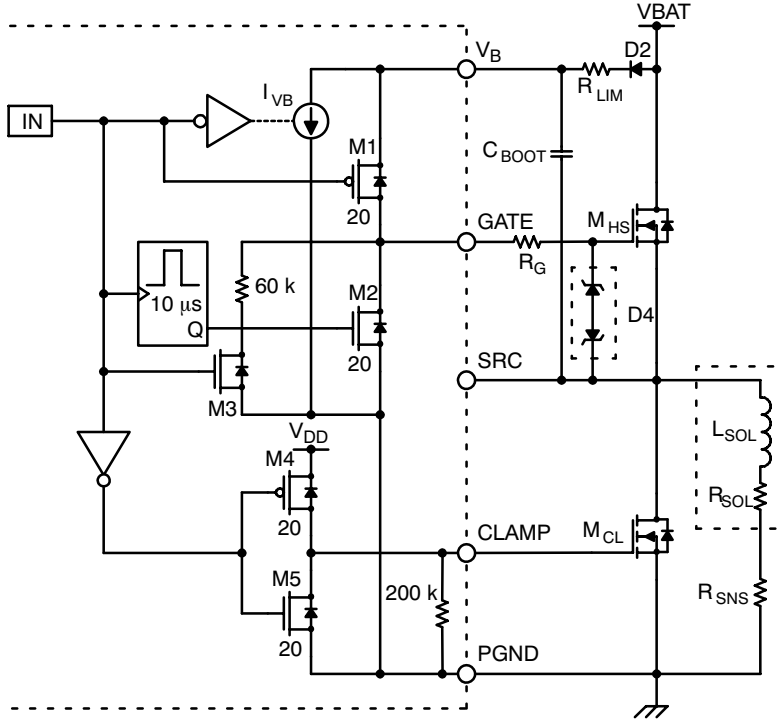
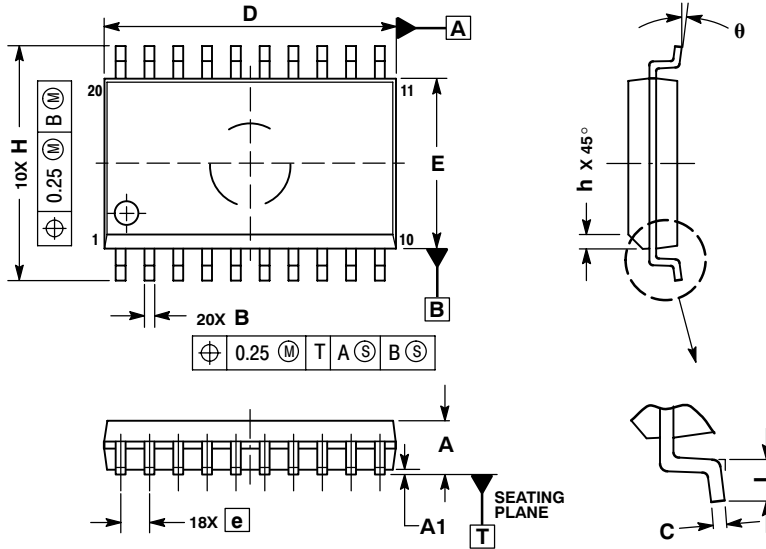

Figure 17. Simplified GATE and CLAMP Predrivers

NCV7510

PACKAGE DIMENSIONS

SO-20L
DW SUFFIX
CASE 751D-05
ISSUE G



NOTES:

1. DIMENSIONS ARE IN MILLIMETERS.
2. INTERPRET DIMENSIONS AND TOLERANCES PER ASME Y14.5M, 1994.
3. DIMENSIONS D AND E DO NOT INCLUDE MOLD PROTRUSION.
4. MAXIMUM MOLD PROTRUSION 0.15 PER SIDE.
5. DIMENSION B DOES NOT INCLUDE DAMBAR PROTRUSION. ALLOWABLE PROTRUSION SHALL BE 0.13 TOTAL IN EXCESS OF B DIMENSION AT MAXIMUM MATERIAL CONDITION.

DIM	MILLIMETERS	
	MIN	MAX
A	2.35	2.65
A1	0.10	0.25
B	0.35	0.49
C	0.23	0.32
D	12.65	12.95
E	7.40	7.60
e	1.27 BSC	
H	10.05	10.55
h	0.25	0.75
L	0.50	0.90
θ	0°	7°

FlexMOS is a trademark of Semiconductor Components Industries, LLC.

ON Semiconductor and are registered trademarks of Semiconductor Components Industries, LLC (SCILLC). SCILLC reserves the right to make changes without further notice to any products herein. SCILLC makes no warranty, representation or guarantee regarding the suitability of its products for any particular purpose, nor does SCILLC assume any liability arising out of the application or use of any product or circuit, and specifically disclaims any and all liability, including without limitation special, consequential or incidental damages. "Typical" parameters which may be provided in SCILLC data sheets and/or specifications can and do vary in different applications and actual performance may vary over time. All operating parameters, including "Typicals" must be validated for each customer application by customer's technical experts. SCILLC does not convey any license under its patent rights nor the rights of others. SCILLC products are not designed, intended, or authorized for use as components in systems intended for surgical implant into the body, or other applications intended to support or sustain life, or for any other application in which the failure of the SCILLC product could create a situation where personal injury or death may occur. Should Buyer purchase or use SCILLC products for any such unintended or unauthorized application, Buyer shall indemnify and hold SCILLC and its officers, employees, subsidiaries, affiliates, and distributors harmless against all claims, costs, damages, and expenses, and reasonable attorney fees arising out of, directly or indirectly, any claim of personal injury or death associated with such unintended or unauthorized use, even if such claim alleges that SCILLC was negligent regarding the design or manufacture of the part. SCILLC is an Equal Opportunity/Affirmative Action Employer. This literature is subject to all applicable copyright laws and is not for resale in any manner.

PUBLICATION ORDERING INFORMATION

LITERATURE FULFILLMENT:
Literature Distribution Center for ON Semiconductor
P.O. Box 5163, Denver, Colorado 80217 USA
Phone: 303-675-2175 or 800-344-3860 Toll Free USA/Canada
Fax: 303-675-2176 or 800-344-3867 Toll Free USA/Canada
Email: orderlit@onsemi.com

N. American Technical Support: 800-282-9855 Toll Free
USA/Canada
Europe, Middle East and Africa Technical Support:
Phone: 421 33 790 2910
Japan Customer Focus Center
Phone: 81-3-5773-3850

ON Semiconductor Website: www.onsemi.com
Order Literature: <http://www.onsemi.com/orderlit>

For additional information, please contact your local Sales Representative

Looking for pricing, stock, or lifecycle information?

Click below to explore more details on WIN SOURCE:

 [View NCV7510DWR2G on WIN SOURCE](#)

 [ON Semiconductor](#) Information

Optimize Your Supply Chain with WIN SOURCE Solutions

-  Global Sourcing Solution
-  Obsolete Management
-  Cost Control Management
-  Shortage Management
-  Alternative Solution
-  Excess Inventory Management