



**THE DATASHEET OF  
NCS2584DTBR2G**



# NCS2584

## Four-Channel Video Driver with Load Detection and Signal Detection

The NCS2584 is a 4-channel high speed video driver with 6th order Butterworth Reconstruction filters on each channel. A first set of 3-channel has High Definition (HD) 34 MHz filters, one per channel. A fourth channel offers an extra driver for Cvbs-type video signal with an 8 MHz filter. The NCS2584 is in fact a combination of a triple HD video driver plus a single Cvbs video driver.

In addition, this four channel video driver integrates an auto shutdown function in order to detect the moment when the DAC is turned on or off. It also embeds a load detection to lower the power consumption when the TV is unplugged. To further reduce the layout and software complexity, the NCS2584 will automatically turn off without any external command. These features help significantly the systems like Blu-Ray™ players or Set Top Boxes to be in line with the restricting energy saving standards on standby modes.

It is designed to be compatible with Digital-to-Analog Converters (DAC) embedded in most video processors.

All channels can accept DC or AC coupled signals. In case of AC-coupled inputs, the internal clamps are enabled. The outputs can drive both AC and DC coupled 150 Ω loads but also two loads of 150 Ω in parallel.

### Features

- 3 High Definition Filters with 6<sup>th</sup> Order Butterworth Filter and 34 MHz Bandwidth for YPbPr 1080i
- One Cvbs Driver Including 6th Order Butterworth 8 MHz Filter
- Integrated Automatic Shutdown Function to Improve Power Consumption Savings When the DAC is Off
- Integrated Load Detection for TV Presence
- Low Pin Count for Layout Simplification
- Internal Fixed Gain: 6 dB ± 0.2
- AC or DC Coupled Inputs and Outputs
- Each channel Capable to Drive 2 Loads of 150 Ω in Parallel
- Operating Supply Voltage Range: +3.3 V and 5.0 V
- TSSOP14 Package
- These Devices are Pb-Free, Halogen Free/BFR Free and are RoHS Compliant

### Typical Application

- Set Top Box Decoder
- DVD and Blu-Ray Player / Recorder
- HDTV, Home Theatre



ON Semiconductor®

<http://onsemi.com>

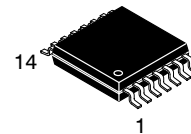

TSSOP-14  
CASE 948G

### MARKING DIAGRAM

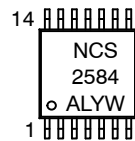

A, AA = Assembly Location  
Y = Year  
W = Work Week  
▪ = Pb-Free Package

\*For additional marking information, refer to Application Note AND8473/D.

### ORDERING INFORMATION

See detailed ordering and shipping information in the package dimensions section on page 15 of this data sheet.

### Related Resource:

Refer to Application Note AND9046/D for details regarding Load Detection and Application Note AND8473/D for details on input video signal detection

# NCS2584

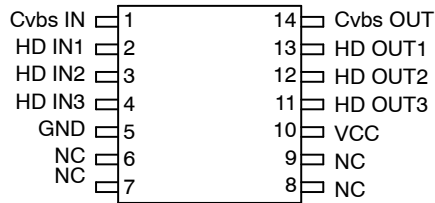

(Top View)

Figure 1. Pinouts

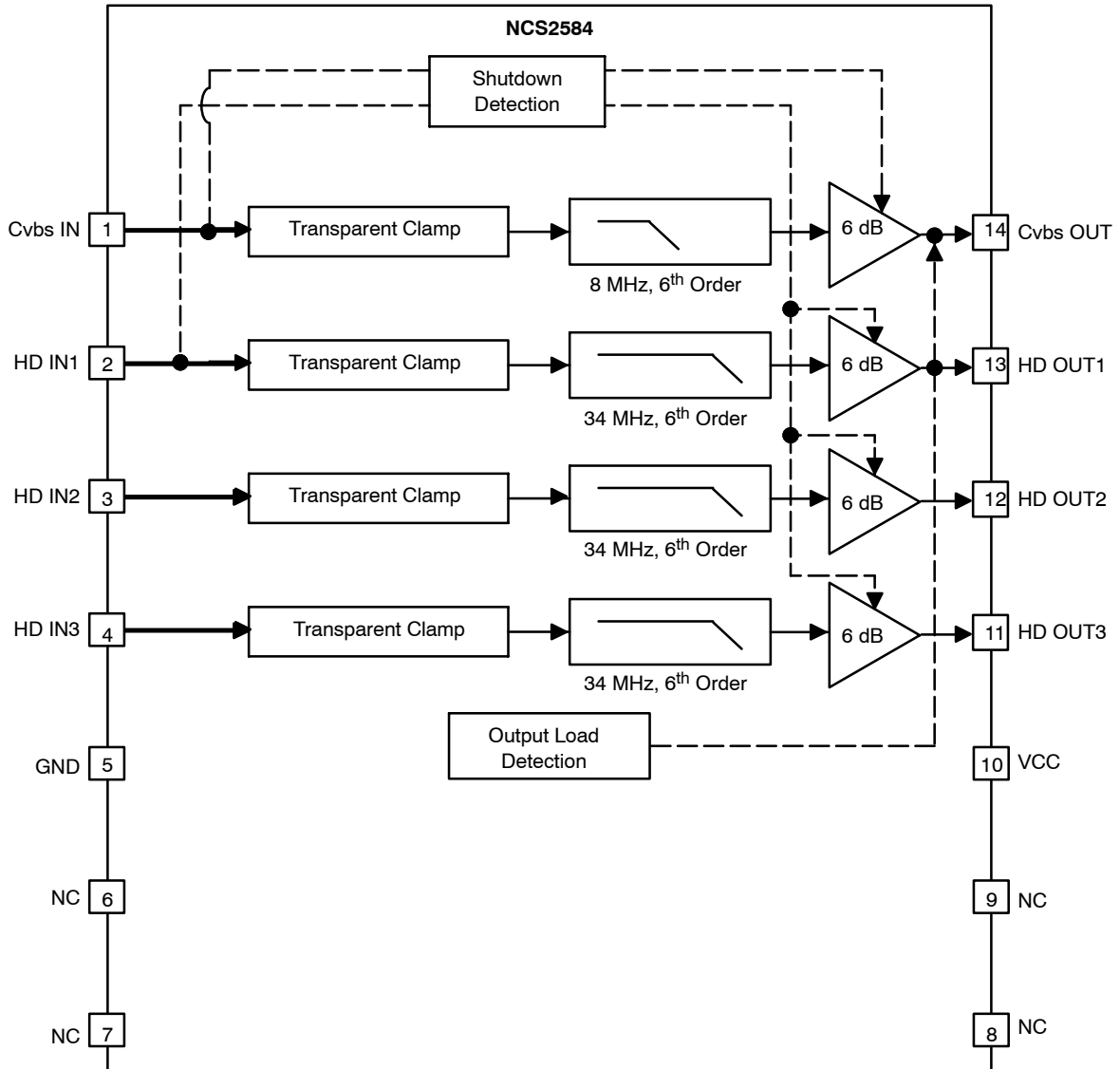

Figure 2. NCS2584 TSSOP-14 Block Diagram

# NCS2584

## TSSOP-14 PIN DESCRIPTION

| Pin No. | Name     | Type   | Description               |
|---------|----------|--------|---------------------------|
| 1       | Cvbs IN  | Input  | Cvbs Input Channel        |
| 2       | HD IN1   | Input  | High Definition Input 1   |
| 3       | HD IN2   | Input  | High Definition Input 2   |
| 4       | HD IN3   | Input  | High Definition Input 3   |
| 5       | GND      | Ground | Ground                    |
| 6       | NC       | NC     | No Connection             |
| 7       | NC       | NC     | No Connection             |
| 8       | NC       | NC     | No Connection             |
| 9       | NC       | NC     | No Connection             |
| 10      | VCC      | Power  | Power Supply 3.3 V or 5 V |
| 11      | HD OUT3  | Output | High Definition Output 3  |
| 12      | HD OUT2  | Output | High Definition Output 2  |
| 13      | HD OUT1  | Output | High Definition Output 1  |
| 14      | Cvbs OUT | Output | Cvbs Output Channel       |

**MAXIMUM RATINGS**

| Rating                                    | Symbol          | Value                       | Unit |
|---|-----------------|-----------------------------|------|
| Power Supply Voltages                     | $V_{CC}$        | $-0.3 \leq V_{CC} \leq 5.5$ | Vdc  |
| Input Voltage Range                       | $V_{I/O}$       | $-0.3 \leq V_I \leq V_{CC}$ | Vdc  |
| Input Differential Voltage Range          | $V_{ID}$        | $-0.3 \leq V_I \leq V_{CC}$ | Vdc  |
| Output Current (Indefinitely) per Channel | $I_O$           | 40                          | mA   |
| Maximum Junction Temperature (Note 1)     | $T_J$           | 150                         | °C   |
| Operating Ambient Temperature             | $T_A$           | -40 to +85                  | °C   |
| Storage Temperature Range                 | $T_{stg}$       | -60 to +150                 | °C   |
| Thermal Resistance, Junction-to-Air       | $R_{\theta JA}$ | 125                         | °C/W |
| ESD Protection Voltage (HBM)              | $V_{esd}$       | 6000                        | V    |

Stresses exceeding Maximum Ratings may damage the device. Maximum Ratings are stress ratings only. Functional operation above the Recommended Operating Conditions is not implied. Extended exposure to stresses above the Recommended Operating Conditions may affect device reliability.

1. Power dissipation must be considered to ensure maximum junction temperature ( $T_J$ ) is not exceeded.

**Maximum Power Dissipation**

The maximum power that can be safely dissipated is limited by the associated rise in junction temperature. For the plastic packages, the maximum safe junction temperature is 150°C. If the maximum is exceeded momentarily, proper circuit operation will be restored as soon as the die temperature is reduced. Leaving the device in the “overheated” condition for an extended period can result in device burnout. To ensure proper operation, it is important to observe the derating curves.

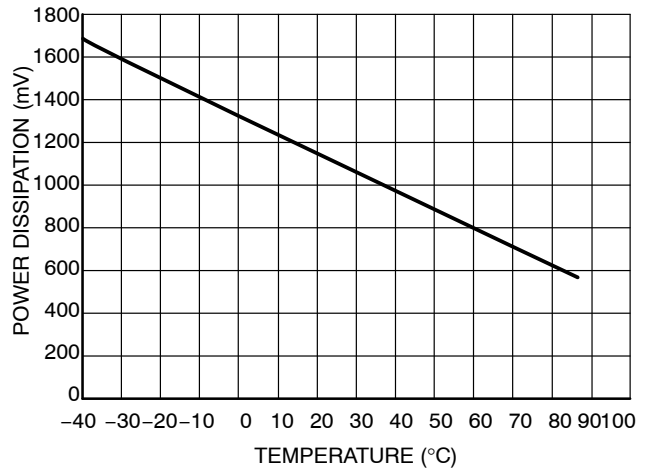

**Figure 3. Power Dissipation vs Temperature**

# NCS2584

## DC ELECTRICAL CHARACTERISTICS ( $V_{CC} = +3.3\text{ V}$ , $T_A = 25^\circ\text{C}$ ; unless otherwise specified)

| Symbol | Characteristics | Conditions | Min | Typ | Max | Unit |
|--------|-----------------|------------|-----|-----|-----|------|
|--------|-----------------|------------|-----|-----|-----|------|

### POWER SUPPLY

|               |  |  |  |    |     |               |
|---------------|--|--|--|----|-----|---------------|
| $I_{CC}$      | All channel Loaded 150 $\Omega$ , signal on all inputs, including the load current |  |  | 73 | 120 | mA            |
| $I_{CC\ sh1}$ | Shutdown current, no load, no input signal   |  |  | 5  | 10  | $\mu\text{A}$ |
| $I_{CC\ sh2}$ | Shutdown current, no load, with input signal on all inputs                         |  |  | 9  | 40  | $\mu\text{A}$ |
| $I_{CC\ SD}$  | Only the SD channel loaded 150 $\Omega$ , signal on all inputs                     |  |  | 20 |     | mA            |
| $I_{CC\ HD}$  | Only the 3 HD channels loaded 150 $\Omega$ , signal on all inputs                  |  |  | 53 |     | mA            |

### DC PERFORMANCE

|          |                                 |                                       |                |                 |     |          |
|----------|---------------------------------|---------------------------------------|----------------|-----------------|-----|----------|
| $V_{cm}$ | Input Common Mode Voltage Range | $V_{CC} = 3.3\text{ V or }5\text{ V}$ | GND            |                 | 1.4 | $V_{PP}$ |
| $V_{OH}$ | Output Voltage High Level       |                                       | $V_{CC} - 0.4$ | $V_{CC} - 0.25$ |     | V        |
| $V_{OL}$ | Output Voltage Low Level        |                                       |                | 280             | 400 | mV       |
| $I_O$    | Output Current                  |                                       | 38             |                 |     | mA       |

## AC ELECTRICAL CHARACTERISTICS FOR STANDARD DEFINITION CHANNELS ( $V_{CC} = +3.3\text{ V}$ , $V_{in} = 1\text{ V}_{PP}$ , $R_{source} = 75\ \Omega$ , $T_A = 25^\circ\text{C}$ , inputs AC-coupled with 0.1 $\mu\text{F}$ , all outputs AC-coupled with 220 $\mu\text{F}$ into 150 $\Omega$ referenced to 400 kHz; unless otherwise specified)

| Symbol           | Characteristics   | Conditions                                     | Min        | Typ        | Max | Unit     |
|------------------|---|--|------------|------------|-----|----------|
| $A_{VSD}$        | Voltage Gain  | $V_{in} = 1\text{ V}$ - All SD Channels        | 5.8        | 6.0        | 6.2 | dB       |
| $BW_{SD}$        | Low Pass Filter Bandwidth                               | -1 dB (Note 2)<br>-3 dB                        | 5.5<br>6.5 | 7.2<br>8.0 |     | MHz      |
| $A_{RSD}$        | Stop-band Attenuation<br>Stop-band Attenuation (Note 2) | @ 16 MHz<br>@ 27 MHz                           | 18<br>43   | 25<br>50   |     | dB       |
| $dG_{SD}$        | Differential Gain Error                                 |  |            | 0.7        |     | %        |
| $d\Phi_{SD}$     | Differential Phase Error                                |  |            | 0.7        |     | $^\circ$ |
| THD              | Total Harmonic Distortion                               | $V_{out} = 1.4\text{ V}_{PP}$ @ 3.58 MHz       |            | 0.35       |     | %        |
| $X_{SD}$         | Channel-to-Channel Crosstalk                            | @ 1 MHz and $V_{in} = 1.4\text{ V}_{PP}$       |            | -57        |     | dB       |
| $SNR_{SD}$       | Signal-to-Noise Ratio                                   | NTC-7 Test Signal, 100 kHz to 4.2 MHz (Note 3) |            | 72         |     | dB       |
| $\Delta t_{SD}$  | Propagation Delay                                       | @ 4.5 MHz                                      |            | 70         |     | ns       |
| $\Delta GD_{SD}$ | Group Delay Variation                                   | 100 kHz to 8 MHz                               |            | 20         |     | ns       |

2. Guaranteed by characterization.
3.  $SNR = 20 \times \log(714\text{ mV} / \text{RMS noise})$

## NCS2584

**AC ELECTRICAL CHARACTERISTICS FOR HIGH DEFINITION CHANNELS** ( $V_{CC} = +3.3\text{ V}$ ,  $V_{in} = 1\text{ V}_{PP}$ ,  $R_{source} = 75\ \Omega$ ,  $T_A = 25^\circ\text{C}$ , inputs AC-coupled with  $0.1\ \mu\text{F}$ , all outputs AC-coupled with  $220\ \mu\text{F}$  into  $150\ \Omega$  referenced to  $400\text{ kHz}$ ; unless otherwise specified)

| Symbol           | Characteristics                              | Conditions   | Min      | Typ               | Max | Unit |
|------------------|--|--|----------|-------------------|-----|------|
| $A_{VHD}$        | Voltage Gain                                 | $V_{in} = 1\text{ V}$ – All HD Channels  | 5.8      | 6.0               | 6.2 | dB   |
| $BW_{HD}$        | Low Pass Filter Bandwidth                    | -1 dB (Note 4)<br>-3 dB  | 26<br>30 | 31<br>34          |     | MHz  |
| $A_{RHD}$        | Stop-band Attenuation                        | @ 44.25 MHz<br>@ 74.25 MHz (Note 4)  | 8<br>33  | 15<br>42          |     | dB   |
| $THD_{HD}$       | Total Harmonic Distortion                    | $V_{out} = 1.4\text{ V}_{PP}$ @ 10 MHz<br>$V_{out} = 1.4\text{ V}_{PP}$ @ 15 MHz<br>$V_{out} = 1.4\text{ V}_{PP}$ @ 20 MHz |          | 0.4<br>0.6<br>0.8 |     | %    |
| $X_{HD}$         | Channel-to-Channel Crosstalk                 | @ 1 MHz and $V_{in} = 1.4\text{ V}_{PP}$   |          | -60               |     | dB   |
| $SNR_{HD}$       | Signal-to-Noise Ratio                        | White Signal, 100 kHz to 30 MHz,<br>(Note 5)   |          | 72                |     | dB   |
| $\Delta t_{HD}$  | Propagation Delay                            |  |          | 25                |     | ns   |
| $\Delta GD_{HD}$ | Group Delay Variation from 100 kHz to 30 MHz |  |          | 10                |     | ns   |

4. Guaranteed by characterization.  
5.  $SNR = 20 \times \log(714\text{ mV} / \text{RMS noise})$

**TIMING CHARACTERISTICS** ( $V_{CC} = +3.3\text{ V}$ ,  $V_{in} = 1\text{ V}_{PP}$ ,  $R_{source} = 75\ \Omega$ ,  $T_A = 25^\circ\text{C}$ , inputs AC-coupled with  $0.1\ \mu\text{F}$ , all outputs AC-coupled with  $220\ \mu\text{F}$  into  $150\ \Omega$  referenced to  $400\text{ kHz}$ ; unless otherwise specified)

| Symbol    | Characteristics       | Conditions                  | Min | Typ | Max | Unit          |
|-----------|-----------------------|-----------------------------|-----|-----|-----|---------------|
| $T_{on}$  | Turn ON Time (Note 6) |                             |     | 2   | 10  | $\mu\text{s}$ |
| $T_{off}$ | Turn OFF Time         | When 0 V Detected on Inputs |     | 200 | 400 | $\mu\text{s}$ |

6. Guaranteed by characterization.

# NCS2584

## DC ELECTRICAL CHARACTERISTICS ( $V_{CC} = +5\text{ V}$ , $T_A = 25^\circ\text{C}$ ; unless otherwise specified)

| Symbol              | Characteristics   | Conditions | Min | Typ | Max | Unit          |
|---------------------|---|------------|-----|-----|-----|---------------|
| <b>POWER SUPPLY</b> |   |            |     |     |     |               |
| $I_{CC}$            | All channel Loaded $150\ \Omega$ , signal on all inputs, including the load current |            |     | 88  | 120 | mA            |
| $I_{CC\ sh1}$       | Shutdown current, no load, no input signal  |            |     | 7   | 10  | $\mu\text{A}$ |
| $I_{CC\ sh2}$       | Shutdown current, no load, with input signal on all inputs                          |            |     | 11  | 40  | $\mu\text{A}$ |
| $I_{CC\ SD}$        | Only the SD channel loaded $150\ \Omega$ , signal on all inputs                     |            |     | 22  |     | mA            |
| $I_{CC\ HD}$        | Only the 3 HD channels loaded $150\ \Omega$ , signal on all inputs                  |            |     | 66  |     | mA            |

## DC PERFORMANCE

|          |                                 |                                       |                |                 |     |          |
|----------|---------------------------------|---------------------------------------|----------------|-----------------|-----|----------|
| $V_{cm}$ | Input Common Mode Voltage Range | $V_{CC} = 3.3\text{ V or }5\text{ V}$ | GND            |                 | 1.4 | $V_{PP}$ |
| $V_{OH}$ | Output Voltage High Level       |                                       | $V_{CC} - 0.4$ | $V_{CC} - 0.25$ |     | V        |
| $V_{OL}$ | Output Voltage Low Level        |                                       |                | 280             | 400 | mV       |
| $I_O$    | Output Current                  |                                       | 38             |                 |     | mA       |

## AC ELECTRICAL CHARACTERISTICS FOR STANDARD DEFINITION CHANNELS ( $V_{CC} = +5\text{ V}$ , $V_{in} = 1\text{ V}_{PP}$ , $R_{source} = 75\ \Omega$ , $T_A = 25^\circ\text{C}$ , inputs AC-coupled with $0.1\ \mu\text{F}$ , all outputs AC-coupled with $220\ \mu\text{F}$ into $150\ \Omega$ referenced to $400\text{ kHz}$ ; unless otherwise specified)

| Symbol           | Characteristics   | Conditions                                     | Min        | Typ        | Max | Unit     |
|------------------|---|--|------------|------------|-----|----------|
| $A_{VSD}$        | Voltage Gain  | $V_{in} = 1\text{ V}$ – All SD Channels        | 5.8        | 6.0        | 6.2 | dB       |
| $BW_{SD}$        | Low Pass Filter Bandwidth                               | -1 dB (Note 7)<br>-3 dB                        | 5.5<br>6.5 | 7.2<br>8.0 |     | MHz      |
| $A_{RSD}$        | Stop-band Attenuation<br>Stop-band Attenuation (Note 7) | @ 16 MHz<br>@ 27 MHz                           | 18<br>43   | 25<br>50   |     | dB       |
| $dG_{SD}$        | Differential Gain Error                                 |  |            | 0.7        |     | %        |
| $d\Phi_{SD}$     | Differential Phase Error                                |  |            | 0.7        |     | $^\circ$ |
| THD              | Total Harmonic Distortion                               | $V_{out} = 1.4\text{ V}_{PP}$ @ 3.58 MHz       |            | 0.35       |     | %        |
| $X_{SD}$         | Channel-to-Channel Crosstalk                            | @ 1 MHz and $V_{in} = 1.4\text{ V}_{PP}$       |            | -57        |     | dB       |
| $SNR_{SD}$       | Signal-to-Noise Ratio                                   | NTC-7 Test Signal, 100 kHz to 4.2 MHz (Note 8) |            | 72         |     | dB       |
| $\Delta t_{SD}$  | Propagation Delay                                       | @ 4.5 MHz                                      |            | 70         |     | ns       |
| $\Delta GD_{SD}$ | Group Delay Variation                                   | 100 kHz to 8 MHz                               |            | 20         |     | ns       |

7. Guaranteed by characterization.

8.  $SNR = 20 \times \log(714\text{ mV} / \text{RMS noise})$

## NCS2584

**AC ELECTRICAL CHARACTERISTICS FOR HIGH DEFINITION CHANNELS** ( $V_{CC} = 5\text{ V}$ ,  $V_{in} = 1\text{ V}_{PP}$ ,  $R_{source} = 75\ \Omega$ ,  $T_A = 25^\circ\text{C}$ , inputs AC-coupled with  $0.1\ \mu\text{F}$ , all outputs AC-coupled with  $220\ \mu\text{F}$  into  $150\ \Omega$  referenced to  $400\ \text{kHz}$ ; unless otherwise specified)

| Symbol           | Characteristics                              | Conditions   | Min      | Typ               | Max | Unit |
|------------------|--|--|----------|-------------------|-----|------|
| $A_{VHD}$        | Voltage Gain                                 | $V_{in} = 1\text{ V}$ – All HD Channels  | 5.8      | 6.0               | 6.2 | dB   |
| $BW_{HD}$        | Low Pass Filter Bandwidth                    | -1 dB (Note 9)<br>-3 dB  | 26<br>30 | 31<br>34          |     | MHz  |
| $A_{RHD}$        | Stop-band Attenuation                        | @ 44.25 MHz<br>@ 74.25 MHz (Note 9)  | 8<br>33  | 15<br>42          |     | dB   |
| $THD_{HD}$       | Total Harmonic Distortion                    | $V_{out} = 1.4\text{ V}_{PP}$ @ 10 MHz<br>$V_{out} = 1.4\text{ V}_{PP}$ @ 15 MHz<br>$V_{out} = 1.4\text{ V}_{PP}$ @ 20 MHz |          | 0.4<br>0.6<br>0.8 |     | %    |
| $X_{HD}$         | Channel-to-Channel Crosstalk                 | @ 1 MHz and $V_{in} = 1.4\text{ V}_{PP}$   |          | -60               |     | dB   |
| $SNR_{HD}$       | Signal-to-Noise Ratio                        | White Signal, 100 kHz to 30 MHz,<br>(Note 10)  |          | 72                |     | dB   |
| $\Delta t_{HD}$  | Propagation Delay                            |  |          | 25                |     | ns   |
| $\Delta GD_{HD}$ | Group Delay Variation from 100 kHz to 30 MHz |  |          | 10                |     | ns   |

9. Guaranteed by characterization.

10.  $SNR = 20 \times \log(714\text{ mV} / \text{RMS noise})$

**TIMING CHARACTERISTICS** ( $V_{CC} = +5\text{ V}$ ,  $V_{in} = 1\text{ V}_{PP}$ ,  $R_{source} = 75\ \Omega$ ,  $T_A = 25^\circ\text{C}$ , inputs AC-coupled with  $0.1\ \mu\text{F}$ , all outputs AC-coupled with  $220\ \mu\text{F}$  into  $150\ \Omega$  referenced to  $400\ \text{kHz}$ ; unless otherwise specified)

| Symbol    | Characteristics        | Conditions                  | Min | Typ | Max | Unit          |
|-----------|------------------------|-----------------------------|-----|-----|-----|---------------|
| $T_{on}$  | Turn ON Time (Note 11) |                             |     | 2   | 10  | $\mu\text{s}$ |
| $T_{off}$ | Turn OFF Time          | When 0 V Detected on Inputs |     | 200 | 400 | $\mu\text{s}$ |

11. Guaranteed by characterization.

TYPICAL CHARACTERISTICS

$V_{CC} = +3.3\text{ V}$ ,  $V_{in} = 1\text{ V}_{pp}$ ,  $R_{source} = 75\ \Omega$ ,  $T_A = 25^\circ\text{C}$ , Inputs AC-coupled with  $0.1\ \mu\text{F}$ , All Outputs AC-coupled with  $220\ \mu\text{F}$  into  $150\ \Omega$   
 Referenced to 400 kHz; unless otherwise specified

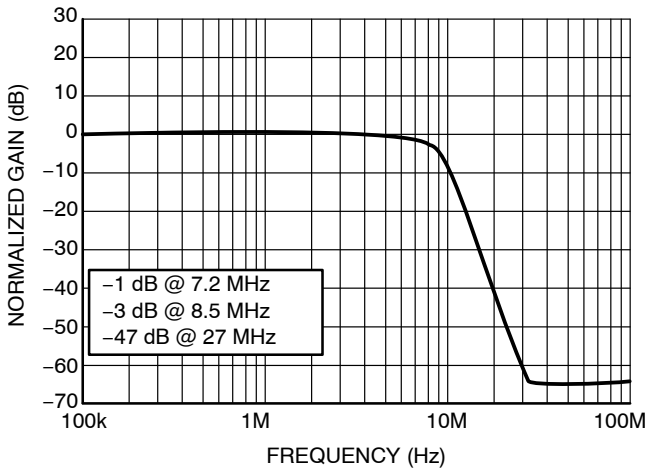

Figure 4. SD Normalized Frequency Response

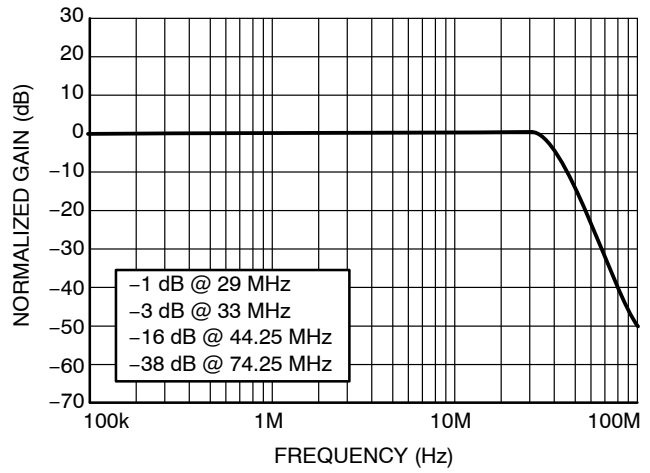

Figure 5. HD Normalized Frequency Response

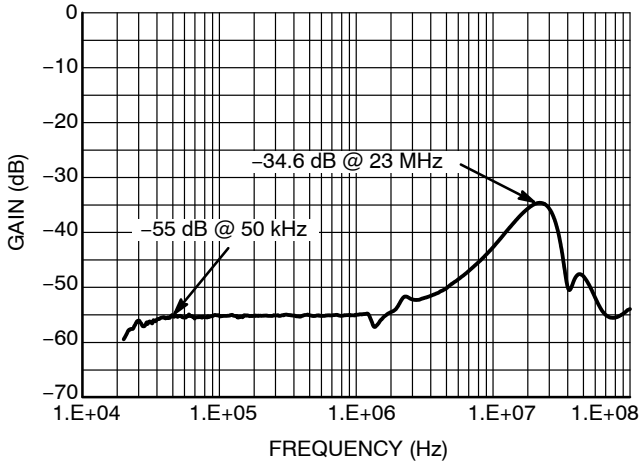

Figure 6. Channel-to-Channel Crosstalk

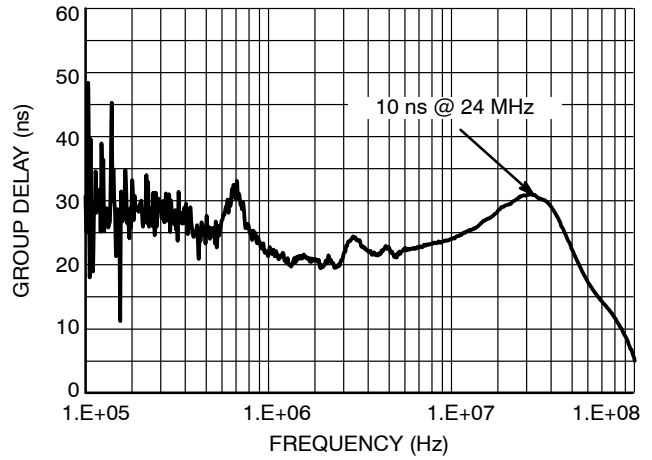

Figure 7. HD Normalized Group Delay

TYPICAL CHARACTERISTICS

$V_{CC} = +3.3\text{ V}$ ,  $V_{in} = 1\text{ V}_{PP}$ ,  $R_{source} = 75\ \Omega$ ,  $T_A = 25^\circ\text{C}$ , Inputs AC-coupled with  $0.1\ \mu\text{F}$ , All Outputs AC-coupled with  $220\ \mu\text{F}$  into  $150\ \Omega$   
 Referred to 400 kHz; unless otherwise specified

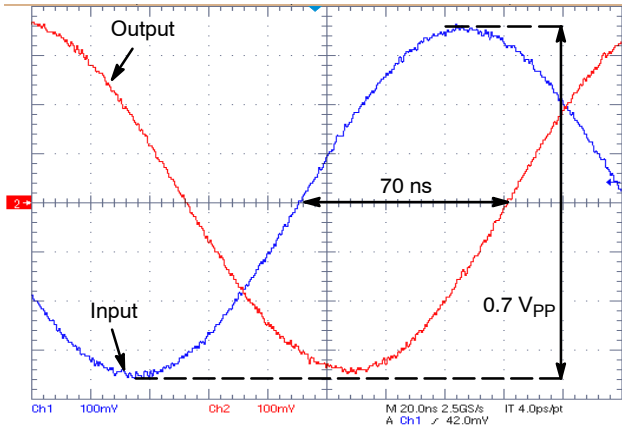

Figure 8. SD Propagation Delay

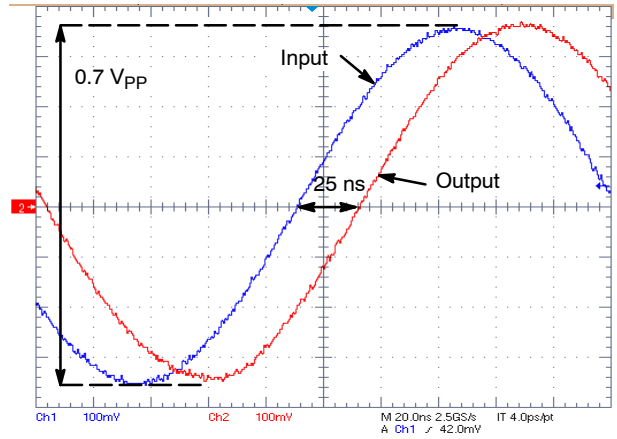

Figure 9. HD Propagation Delay

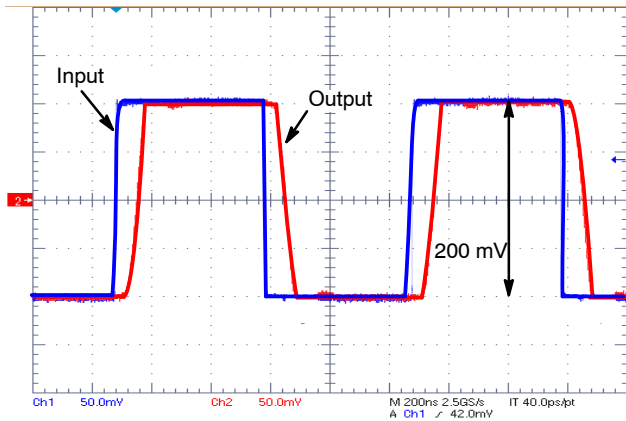

Figure 10. SD Small Signal Response

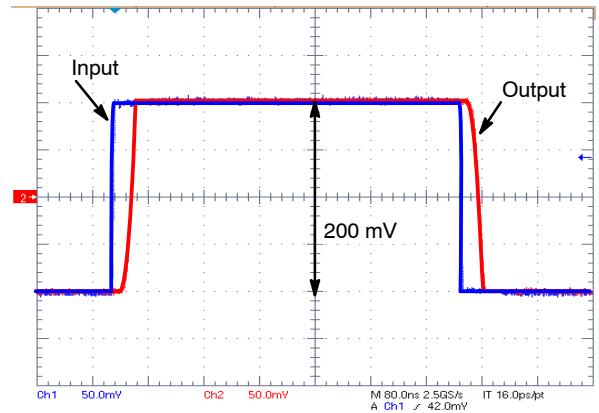

Figure 11. HD Small Signal Response

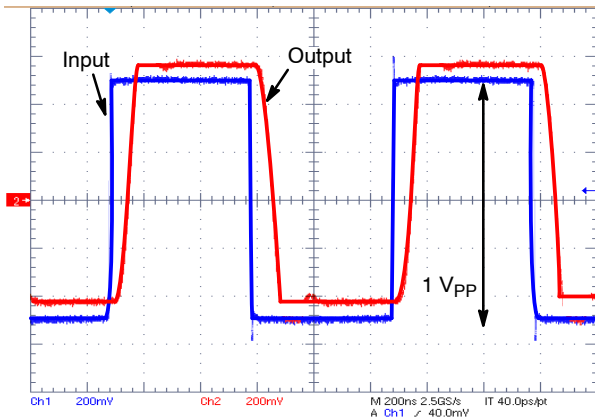

Figure 12. SD Large Signal Response

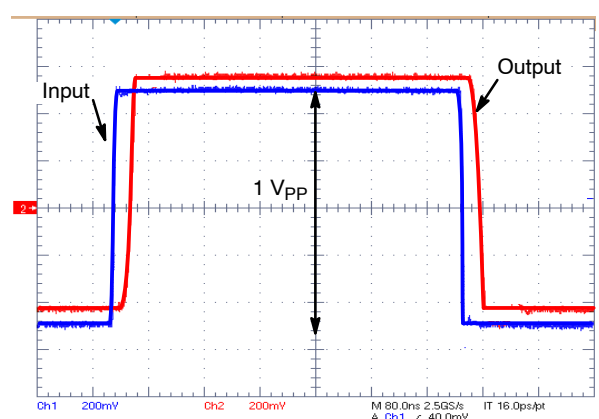

Figure 13. HD Large Signal Response

TYPICAL CHARACTERISTICS

$V_{CC} = +3.3\text{ V}$ ,  $V_{in} = 1\text{ V}_{PP}$ ,  $R_{source} = 75\ \Omega$ ,  $T_A = 25^\circ\text{C}$ , Inputs AC-coupled with  $0.1\ \mu\text{F}$ , All Outputs AC-coupled with  $220\ \mu\text{F}$  into  $150\ \Omega$   
 Referred to 400 kHz; unless otherwise specified

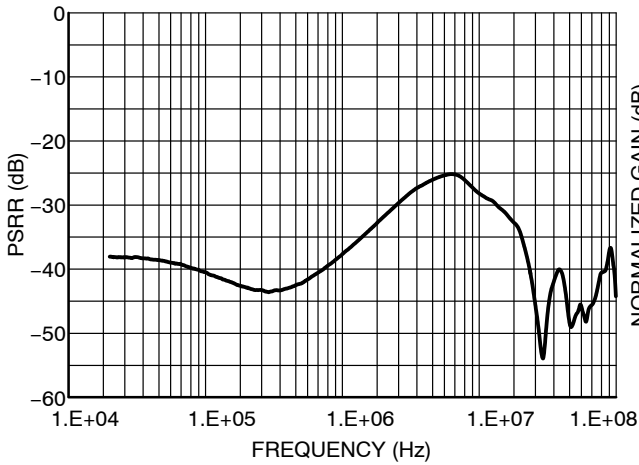

Figure 16. SD and HD  $V_{CC}$  PSRR vs. Frequency

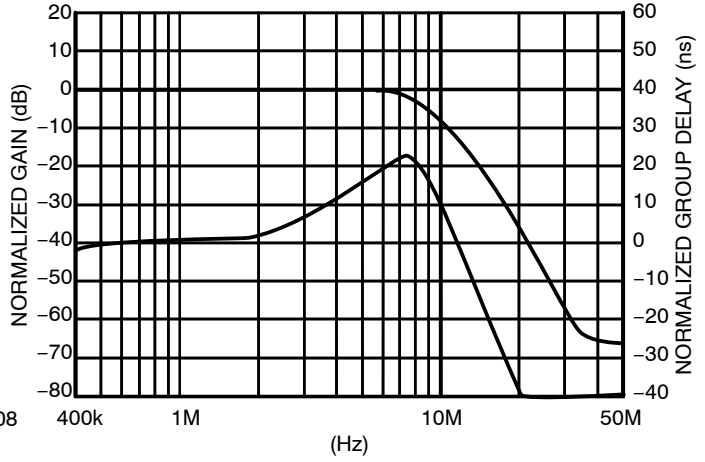

Figure 14. SD Frequency Response and Group Delay

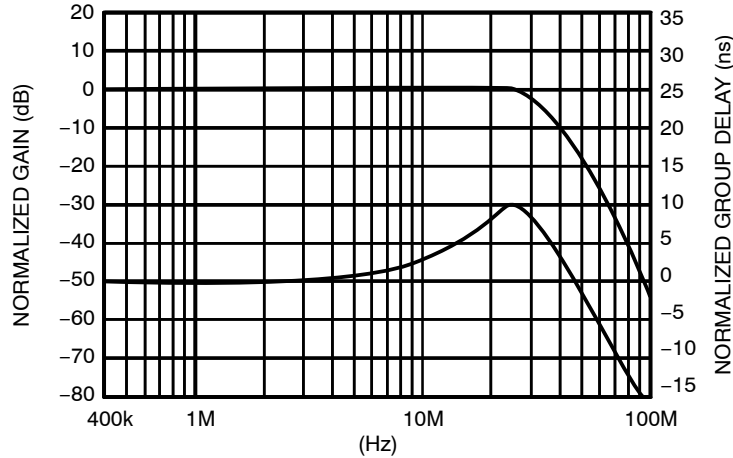

Figure 15. HD Frequency Response and Group Delay

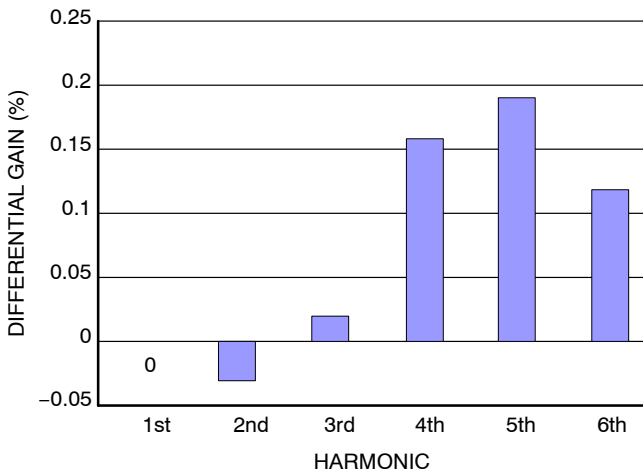

Figure 17. SD Differential Gain

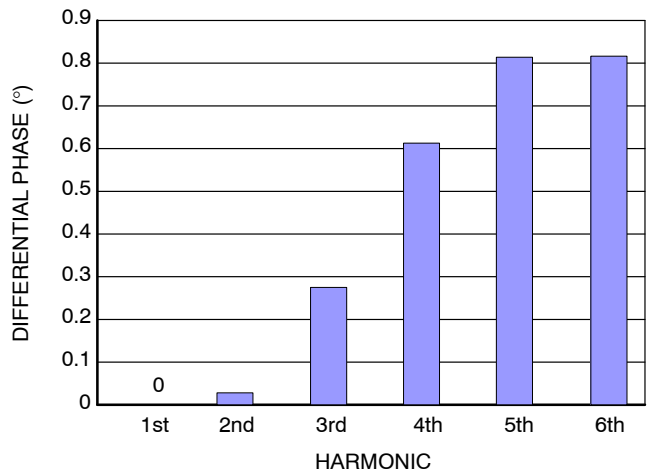

Figure 18. SD Differential Phase

## APPLICATIONS INFORMATION

The NCS2584 quad video driver has been optimized for Standard and High Definition video applications covering the requirements of the standards Composite video (Cvbs), Component Video (720p/1080i). The three HD channels have 34 MHz filters to cover high definition-like video applications. A fourth channel implements one standard definition filter of 8 MHz bandwidth to drive the Cvbs signal.

In the regular mode of operation, each channel provides an internal voltage-to-voltage gain of 2 from input to output. This effectively reduces the number of external components required as compared to discrete approach

implemented with stand alone op amps. An internal level shifter is employed shifting up the output voltage by adding an offset of 280 mV on the outputs. This prevents sync pulse clipping and allows DC-coupled output to the 150  $\Omega$  video load. In addition, the NCS2584 integrates a 6<sup>th</sup> order Butterworth filter for each. This allows rejection of the aliases or unwanted over-sampling effects produced by the video DAC. Similarly for the case of DVD recorders which use a ADC, this anti-aliasing filter (reconstruction filter) will avoid picture quality issue and will help filtration of parasitic signals caused by EMI interference.

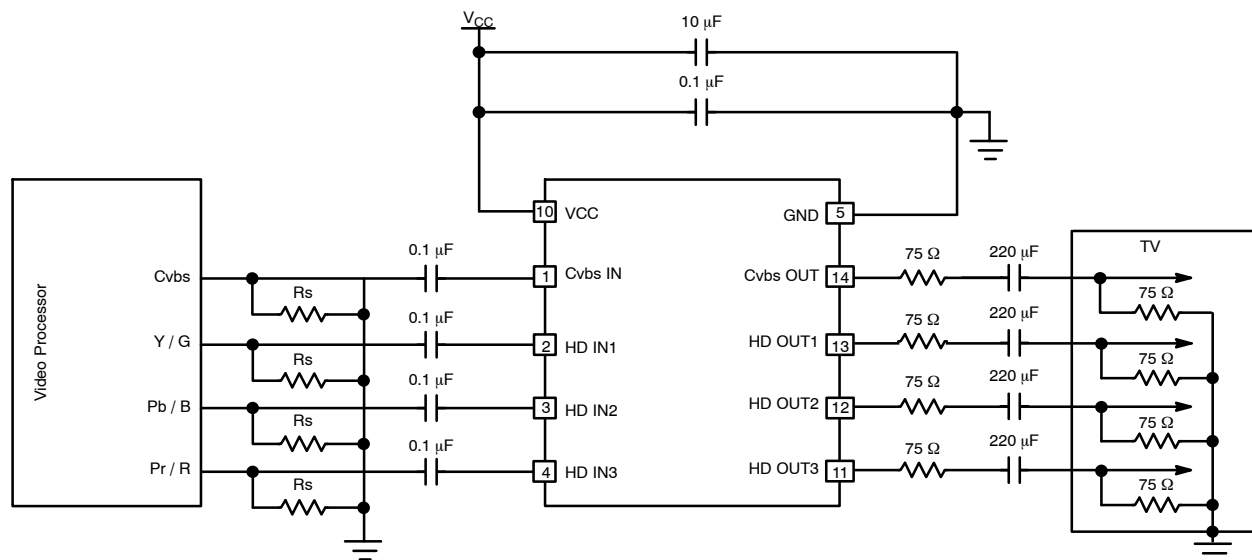

Figure 19. AC-Coupled Configuration at the Input and Output

A built-in diode-like clamp is used into the chip for each channel to support the AC-coupled mode of operation. The clamp is active when the input signal goes below 0 V.

The built-in clamp and level shifter allow the device to operate in different configuration modes depending on the DAC output signal level and the input common mode voltage of the video driver. When the configuration is DC-Coupled at the Inputs and Outputs, the 0.1  $\mu\text{F}$  and 220  $\mu\text{F}$  coupling capacitors are no longer used, and the clamps are in that case inactive; this configuration provides a low cost solution which can be implemented with few external components (Figure 19). It also require the user to ensure the input voltage range stays within 0 V to 1.4 V.

The input is AC-coupled when either the input-signal amplitude goes over the range 0 V to 1.4 V. Activating the clamp becomes mandatory and the use of the 0.1  $\mu\text{F}$  is necessary.

The output AC-coupling configuration is advantageous for eliminating DC ground loop with the drawback of making the device more sensitive to video line or field tilt issues. In some cases, it may be necessary to increase the nominal 220  $\mu\text{F}$  capacitor value. Meanwhile the AC

coupling configuration ensures the maximum compatibility with all sorts of displays.

#### Shutdown Mode

The NCS2584 integrates a shutdown mode function which allows the device to detect when the video DAC turns on or off. When the video DACs turn ON, the video drivers will turn ON on as soon as they detect a stimulus. Meanwhile if any glitch happens on the input line, embedded filters will ignore them to prevent undesired behavior. In this case, the turn on time is typically around 2  $\mu\text{s}$  to avoid any missing information. When the chipset turns on, it has to go through a boot sequence which is significantly longer than this turn on time. Then, the video drivers will go to a shutdown mode in order to significantly lower the power consumption only when no more stimulus is detected from the video DACs. In addition, the NCS2584 integrates also a load detection function. It only occurs on the Cvbs which is an independent signal and the first HD channel which contains the synchronization information. It identify when the user plugs the analog video lines of the TV or not. If these are not plugged, then the device goes into a standby mode to reduce the power consumption of the system. The device is in fact

capable of recognizing the load of the TV. With the ENERGY STAR® requirements, these innovative and patented features will perfectly fit with the power saving specifications.

**DC-Coupled Output**

The outputs of the NCS2584 can be DC-coupled to a 150 Ω load (Figure 20). This has the advantage of eliminating the AC-coupling capacitors at the output by reducing the number of external components and saving space on the board. This can be a key advantage for some applications with limited space.

The problems of field tilt effects on the video signal are also eliminated providing the best video quality with optimal dynamic or peak-to-peak amplitude of the video signal allowing operating thanks to the built-in level shifter without risk of signal clipping. In this coupling configuration the average output voltage is higher than 0 V and the power consumption can be a little higher than with an AC-coupled configuration.

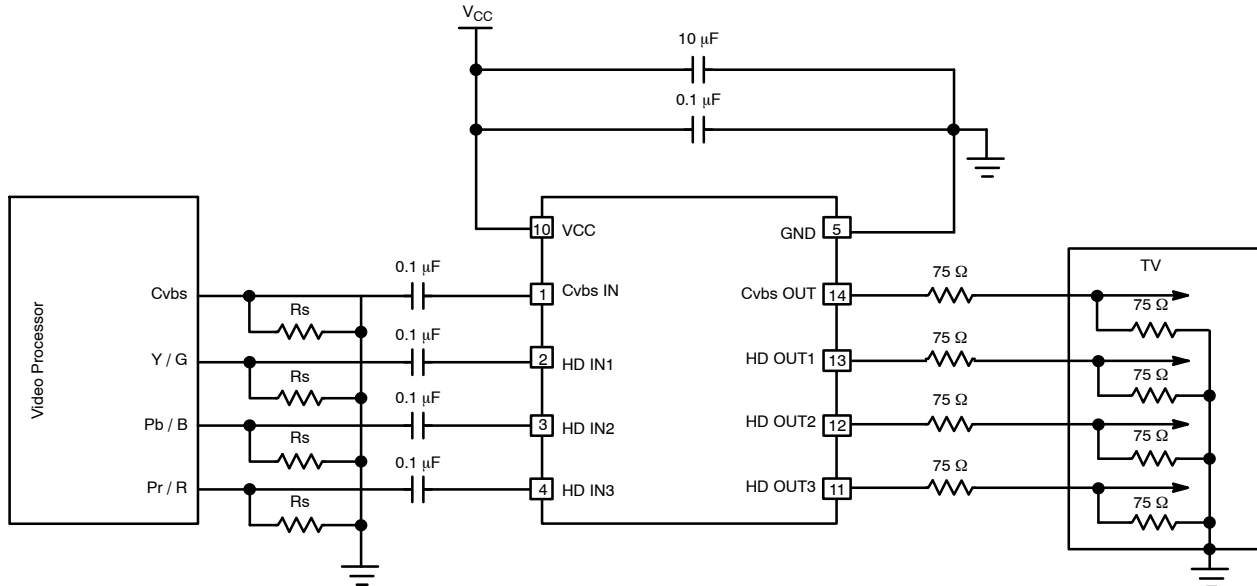

**Figure 20. AC-Coupled Input and DC-Coupled Output Configuration**

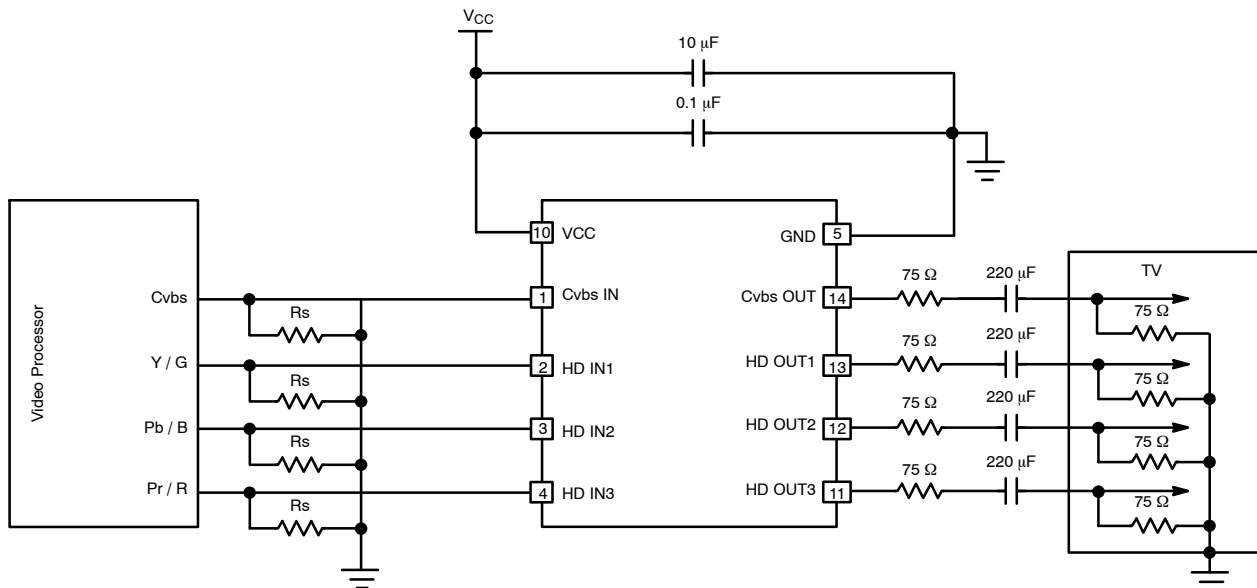

**Figure 21. DC-Coupled Inputs and AC-Coupled Outputs**

# NCS2584

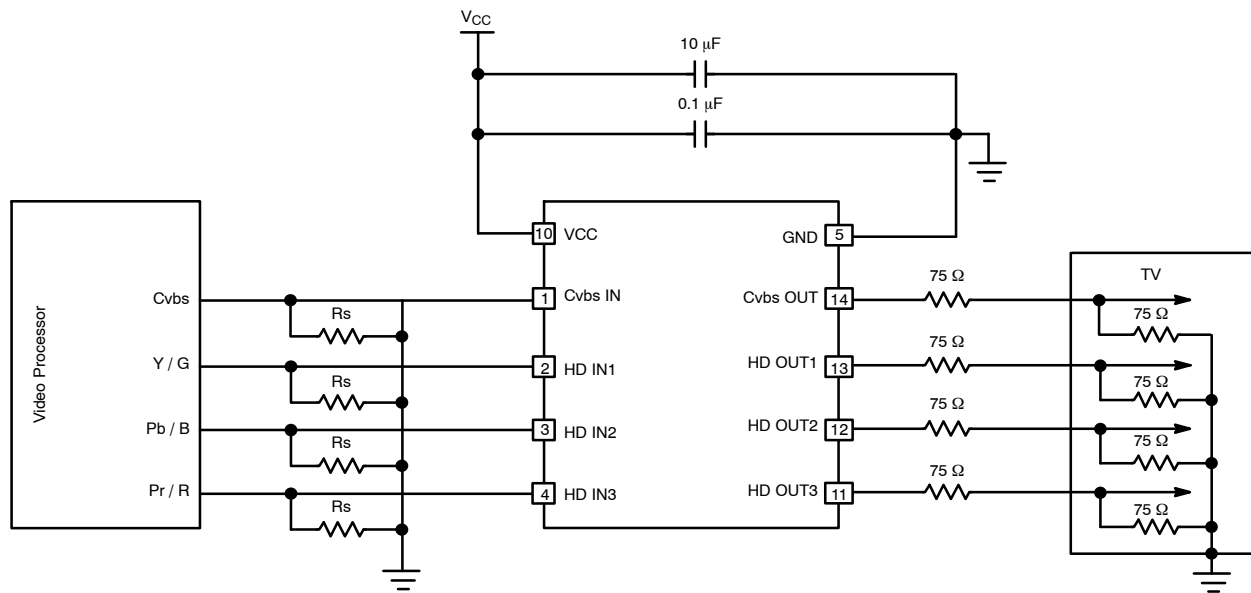

Figure 22. DC-Coupled Inputs and Outputs

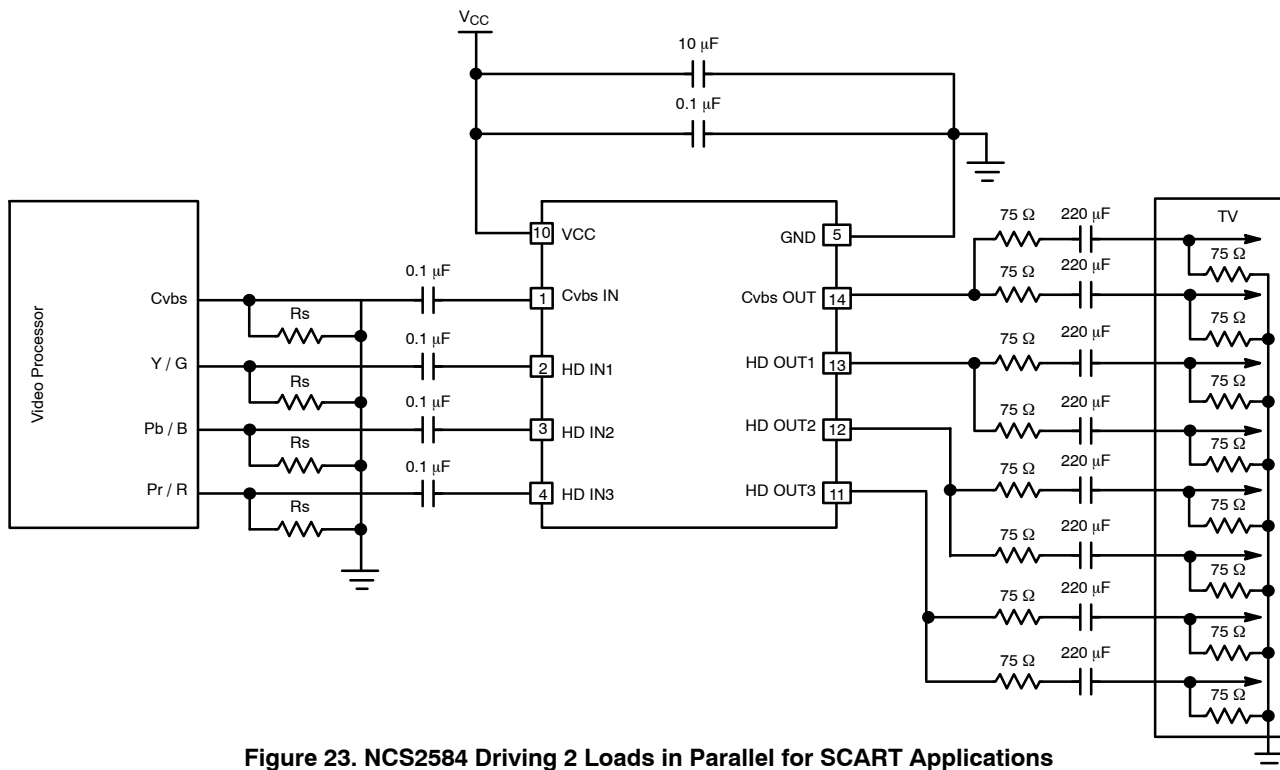

Figure 23. NCS2584 Driving 2 Loads in Parallel for SCART Applications

**Video Driving Capability**

With an output current capability of 40 mA the NCS2584 was designed to be able to drive at least two video display loads in parallel. This type of application is illustrated in Figure 23. Figure 24 (multiburst) and Figure 25 (linearity) show that the video signal can efficiently drive a 75 Ω equivalent load and not degrade the video performance.

**ESD Protection**

All the device pins are protected against electrostatic discharge at a level of 6 kV following HBM JEDEC standards. This feature has been considered with a particular attention with ESD structure able to sustain the typical values requested by the systems like Set Top Boxes or Blue-Ray players. This parameter is particularly important for video driver which usually constitutes the last stage in the video chain before the video output connector.

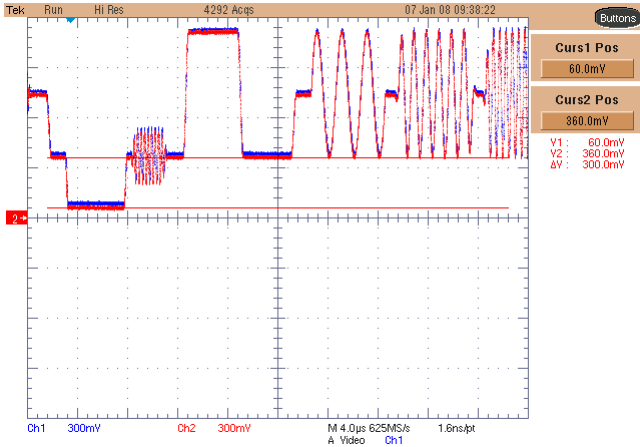

Figure 24. Multiburst Test with Two 150 Ω Loads

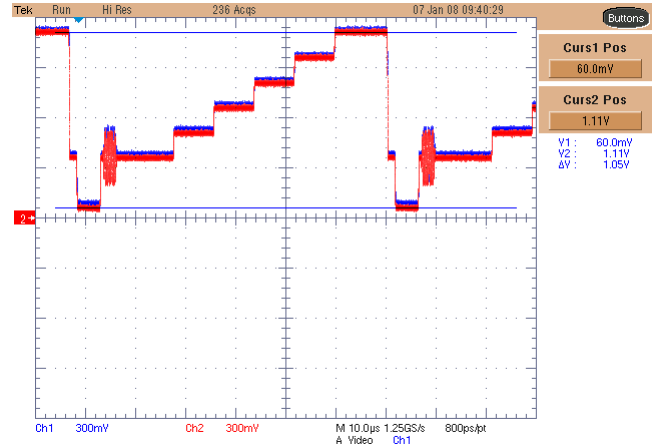

Figure 25. Linearity Test with Two 150 Ω Loads

**ORDERING INFORMATION**

| Device        | Package               | Shipping†          |
|---------------|-----------------------|--------------------|
| NCS2584DTBR2G | TSSOP-14<br>(Pb-Free) | 2500 / Tape & Reel |

†For information on tape and reel specifications, including part orientation and tape sizes, please refer to our Tape and Reel Packaging Specifications Brochure, BRD8011/D.

# NCS2584

## PACKAGE DIMENSIONS

TSSOP-14  
CASE 948G  
ISSUE B

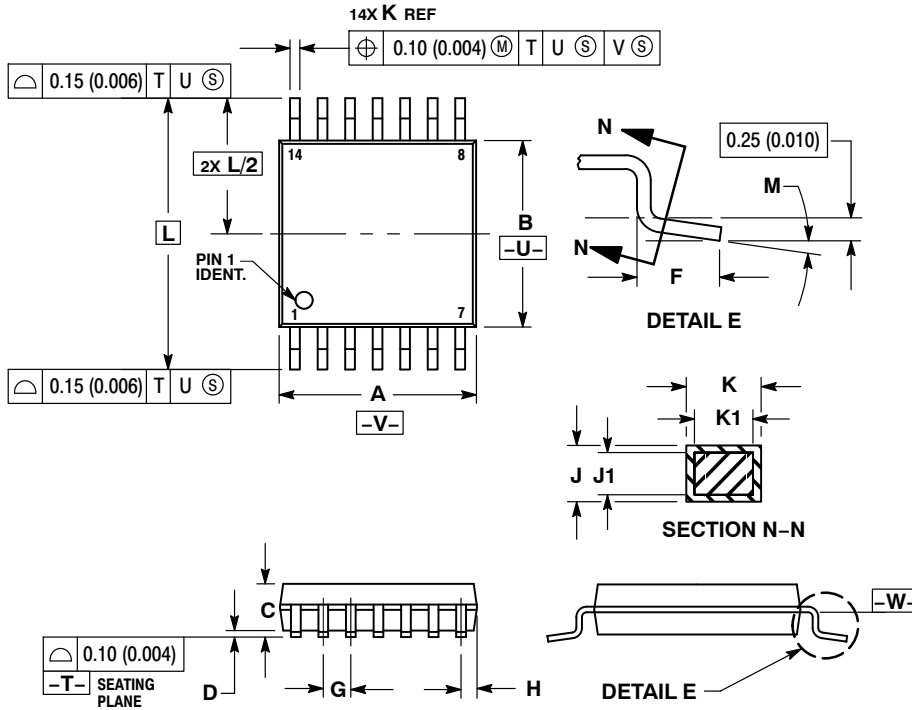

### NOTES:

1. DIMENSIONING AND TOLERANCING PER ANSI Y14.5M, 1982.
2. CONTROLLING DIMENSION: MILLIMETER.
3. DIMENSION A DOES NOT INCLUDE MOLD FLASH, PROTRUSIONS OR GATE BURRS. MOLD FLASH OR GATE BURRS SHALL NOT EXCEED  $0.15 (0.006)$  PER SIDE.
4. DIMENSION B DOES NOT INCLUDE INTERLEAD FLASH OR PROTRUSION. INTERLEAD FLASH OR PROTRUSION SHALL NOT EXCEED  $0.25 (0.010)$  PER SIDE.
5. DIMENSION K DOES NOT INCLUDE DAMBAR PROTRUSION. ALLOWABLE DAMBAR PROTRUSION SHALL BE  $0.08 (0.003)$  TOTAL IN EXCESS OF THE K DIMENSION AT MAXIMUM MATERIAL CONDITION.
6. TERMINAL NUMBERS ARE SHOWN FOR REFERENCE ONLY.
7. DIMENSION A AND B ARE TO BE DETERMINED AT DATUM PLANE  $-W-$ .

| DIM | MILLIMETERS         |      | INCHES              |       |
|-----|---------------------|------|---------------------|-------|
|     | MIN                 | MAX  | MIN                 | MAX   |
| A   | 4.90                | 5.10 | 0.193               | 0.200 |
| B   | 4.30                | 4.50 | 0.169               | 0.177 |
| C   | ---                 | 1.20 | ---                 | 0.047 |
| D   | 0.05                | 0.15 | 0.002               | 0.006 |
| F   | 0.50                | 0.75 | 0.020               | 0.030 |
| G   | 0.65 BSC            |      | 0.026 BSC           |       |
| H   | 0.50                | 0.60 | 0.020               | 0.024 |
| J   | 0.09                | 0.20 | 0.004               | 0.008 |
| J1  | 0.09                | 0.16 | 0.004               | 0.006 |
| K   | 0.19                | 0.30 | 0.007               | 0.012 |
| K1  | 0.19                | 0.25 | 0.007               | 0.010 |
| L   | 6.40 BSC            |      | 0.252 BSC           |       |
| M   | $0^\circ$ $8^\circ$ |      | $0^\circ$ $8^\circ$ |       |

### SOLDERING FOOTPRINT\*

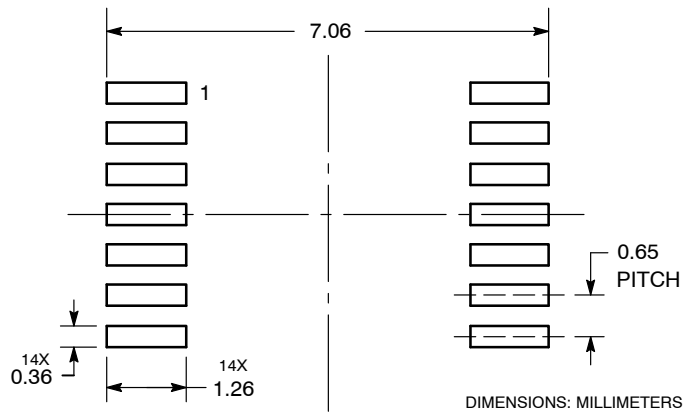

\*For additional information on our Pb-Free strategy and soldering details, please download the ON Semiconductor Soldering and Mounting Techniques Reference Manual, SOLDERRM/D.

Blu-ray and Blu-ray Disc are trademarks of Blu-ray Disc Association.  
ENERGY STAR and the ENERGY STAR mark are registered U.S. marks.

**ON Semiconductor** and  are registered trademarks of Semiconductor Components Industries, LLC (SCILLC). SCILLC owns the rights to a number of patents, trademarks, copyrights, trade secrets, and other intellectual property. A listing of SCILLC's product/patent coverage may be accessed at [www.onsemi.com/site/pdf/Patent-Marking.pdf](http://www.onsemi.com/site/pdf/Patent-Marking.pdf). SCILLC reserves the right to make changes without further notice to any products herein. SCILLC makes no warranty, representation or guarantee regarding the suitability of its products for any particular purpose, nor does SCILLC assume any liability arising out of the application or use of any product or circuit, and specifically disclaims any and all liability, including without limitation special, consequential or incidental damages. "Typical" parameters which may be provided in SCILLC data sheets and/or specifications can and do vary in different applications and actual performance may vary over time. All operating parameters, including "Typicals" must be validated for each customer application by customer's technical experts. SCILLC does not convey any license under its patent rights nor the rights of others. SCILLC products are not designed, intended, or authorized for use as components in systems intended for surgical implant into the body, or other applications intended to support or sustain life, or for any other application in which the failure of the SCILLC product could create a situation where personal injury or death may occur. Should Buyer purchase or use SCILLC products for any such unintended or unauthorized application, Buyer shall indemnify and hold SCILLC and its officers, employees, subsidiaries, affiliates, and distributors harmless against all claims, costs, damages, and expenses, and reasonable attorney fees arising out of, directly or indirectly, any claim of personal injury or death associated with such unintended or unauthorized use, even if such claim alleges that SCILLC was negligent regarding the design or manufacture of the part. SCILLC is an Equal Opportunity/Affirmative Action Employer. This literature is subject to all applicable copyright laws and is not for resale in any manner.

## PUBLICATION ORDERING INFORMATION

### LITERATURE FULFILLMENT:

Literature Distribution Center for ON Semiconductor  
P.O. Box 5163, Denver, Colorado 80217 USA  
**Phone:** 303-675-2175 or 800-344-3860 Toll Free USA/Canada  
**Fax:** 303-675-2176 or 800-344-3867 Toll Free USA/Canada  
**Email:** [orderlit@onsemi.com](mailto:orderlit@onsemi.com)

**N. American Technical Support:** 800-282-9855 Toll Free  
USA/Canada  
**Europe, Middle East and Africa Technical Support:**  
Phone: 421 33 790 2910  
**Japan Customer Focus Center**  
Phone: 81-3-5817-1050

**ON Semiconductor Website:** [www.onsemi.com](http://www.onsemi.com)  
**Order Literature:** <http://www.onsemi.com/orderlit>  
For additional information, please contact your local  
Sales Representative

## Looking for pricing, stock, or lifecycle information?

Click below to explore more details on WIN SOURCE:

- ⊖ [View NCS2584DTBR2G on WIN SOURCE](#)
- ⊖ [ON Semiconductor Information](#)

## Optimize Your Supply Chain with WIN SOURCE Solutions

- ✓ Global Sourcing Solution
- ✓ Obsolete Management
- ✓ Cost Control Management
- ✓ Shortage Management
- ✓ Alternative Solution
- ✓ Excess Inventory Management