



**THE DATASHEET OF  
NB100ELT23LDTG**



# NB100ELT23L

## 3.3V Dual Differential LVPECL/LVDS to LVTTTL Translator

The NB100ELT23L is a dual differential LVPECL/LVDS to LVTTTL translator. Because LVPECL (Positive ECL) or LVDS levels are used, only +3.3 V and ground are required. The small outline 8-lead package and the dual gate design of the ELT23L makes it ideal for applications which require the translation of a clock and a data signal.

The ELT23L is available in only the ECL 100K standard. Since there are no LVPECL outputs or an external  $V_{BB}$  reference, the ELT23L does not require both ECL standard versions. The LVPECL inputs are differential. Therefore, the NB100ELT23L can accept any standard differential LVPECL/LVDS input referenced from a  $V_{CC}$  of +3.3 V.

### Features

- 2.1 ns Typical Propagation Delay
- Maximum Operating Frequency > 160 MHz
- 24 mA LVTTTL Outputs
- Operating Range:  $V_{CC} = 3.0\text{ V}$  to  $3.6\text{ V}$  with  $GND = 0\text{ V}$
- These Devices are Pb-Free, Halogen Free/BFR Free and are RoHS Compliant



ON Semiconductor®

[www.onsemi.com](http://www.onsemi.com)

### MARKING DIAGRAMS\*

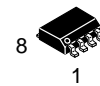

SOIC-8  
D SUFFIX  
CASE 751

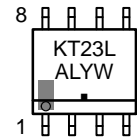

TSSOP-8  
DT SUFFIX  
CASE 948R

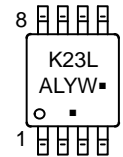

A = Assembly Location  
L = Wafer Lot  
Y = Year  
W = Work Week  
▪ = Pb-Free Package

(Note: Microdot may be in either location)

\*For additional marking information, refer to Application Note AND8002/D.

### ORDERING INFORMATION

See detailed ordering and shipping information in the package dimensions section on page 5 of this data sheet.

# NB100ELT23L

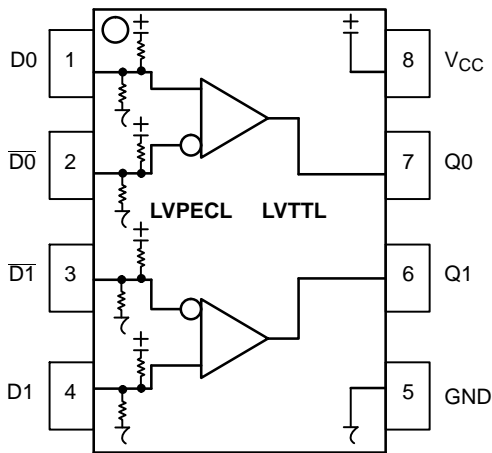

**Figure 1. 8-Lead Pinout (Top View) and Logic Diagram**

**Table 1. PIN DESCRIPTION**

| PIN                    | FUNCTION                   |
|------------------------|----------------------------|
| Q0, Q1                 | LVTTTL Outputs             |
| D0*, D1*<br>D0**, D1** | Differential LVPECL Inputs |
| V <sub>CC</sub>        | Positive Supply            |
| GND                    | Ground                     |

\*Pins will default to  $V_{CC}/2$  when left open. If connected to a common termination voltage under no signal conditions, then the device will be susceptible to self-oscillation.

\*\*Pins will default to  $2/3 V_{CC}$  when left open. If connected to a common termination voltage under no signal conditions, then the device will be susceptible to self-oscillation. See AND8020, Section 6 for options.

**Table 2. ATTRIBUTES**

| Characteristics   | Value  |
|---|--|
| Internal Input Pulldown Resistor                              | D<br>D-bar<br>50 kΩ<br>75 kΩ   |
| Internal Input Pullup Resistor                                | 50 kΩ  |
| ESD Protection  | Human Body Model<br>Machine Model<br>Charged Device Model<br>> 1.5 kV<br>> 100 V<br>> 2 kV |
| Moisture Sensitivity, Indefinite Time Out of Drypack (Note 1) | Pb-Free Pkg  |
|   | SO-8<br>TSSOP-8<br>Level 1<br>Level 3  |
| Flammability Rating   | Oxygen Index: 28 to 34<br>UL 94 V-0 @ 1.25 in  |
| Transistor Count  | 91 Devices   |
| Meets or exceeds JEDEC Spec EIA/JESD78 IC Latchup Test        |  |

1. For additional information, see Application Note AND8003/D.

# NB100ELT23L

**Table 3. MAXIMUM RATINGS**

| Symbol           | Parameter                                | Condition 1         | Condition 2                      | Rating      | Unit         |
|------------------|--|---------------------|----------------------------------|-------------|--------------|
| V <sub>CC</sub>  | Power Supply                             | GND = 0 V           |                                  | 3.8         | V            |
| V <sub>I</sub>   | Input Voltage                            | GND = 0 V           | V <sub>I</sub> ≤ V <sub>CC</sub> | 3.8         | V            |
| I <sub>out</sub> | Output Current                           | Continuous Surge    |                                  | 50<br>100   | mA<br>mA     |
| T <sub>A</sub>   | Operating Temperature Range              |                     |                                  | -40 to +85  | °C           |
| T <sub>stg</sub> | Storage Temperature Range                |                     |                                  | -65 to +150 | °C           |
| θ <sub>JA</sub>  | Thermal Resistance (Junction-to-Ambient) | 0 lfp<br>500 lfp    | SO-8<br>SO-8                     | 190<br>130  | °C/W<br>°C/W |
| θ <sub>JC</sub>  | Thermal Resistance (Junction-to-Case)    | Standard Board      | SO-8                             | 41 to 44    | °C/W         |
| θ <sub>JA</sub>  | Thermal Resistance (Junction-to-Ambient) | 0 lfp<br>500 lfp    | TSSOP-8<br>TSSOP-8               | 185<br>140  | °C/W<br>°C/W |
| θ <sub>JC</sub>  | Thermal Resistance (Junction-to-Case)    | Standard Board      | TSSOP-8                          | 41 to 44    | °C/W         |
| T <sub>sol</sub> | Wave Solder Pb-Free                      | <2 to 3 sec @ 260°C |                                  | 265         | °C           |

Stresses exceeding those listed in the Maximum Ratings table may damage the device. If any of these limits are exceeded, device functionality should not be assumed, damage may occur and reliability may be affected.

**Table 4. PECL DC CHARACTERISTICS** V<sub>CC</sub> = 3.3 V, GND = 0 V (Note 2)

| Symbol             | Characteristic                                | -40°C |     |      | 25°C |     |      | 85°C |     |      | Unit |
|--------------------|---|-------|-----|------|------|-----|------|------|-----|------|------|
|                    |   | Min   | Typ | Max  | Min  | Typ | Max  | Min  | Typ | Max  |      |
| I <sub>CCH</sub>   | Power Supply Current (Outputs set to HIGH)    | 10    | 23  | 30   | 10   | 23  | 30   | 10   | 24  | 30   | mA   |
| I <sub>CCL</sub>   | Power Supply Current (Outputs set to LOW)     | 15    | 26  | 35   | 15   | 26  | 35   | 15   | 27  | 35   | mA   |
| V <sub>IH</sub>    | Input HIGH Voltage                            | 2075  |     | 2420 | 2075 |     | 2420 | 2075 |     | 2420 | mV   |
| V <sub>IL</sub>    | Input LOW Voltage                             | 1355  |     | 1675 | 1355 |     | 1675 | 1355 |     | 1675 | mV   |
| V <sub>IHCMR</sub> | Input HIGH Voltage Common Mode Range (Note 3) | 1.2   |     | 3.3  | 1.2  |     | 3.3  | 1.2  |     | 3.3  | V    |
| I <sub>IH</sub>    | Input HIGH Current                            |       |     | 150  |      |     | 150  |      |     | 150  | μA   |
| I <sub>IL</sub>    | Input LOW Current                             | -150  |     |      | -150 |     |      | -150 |     |      | μA   |

NOTE: Device will meet the specifications after thermal equilibrium has been established when mounted in a test socket or printed circuit board with maintained transverse airflow greater than 500 lfp.

2. All values vary 1:1 with V<sub>CC</sub>.

3. V<sub>IHCMR</sub> minimum varies 1:1 with V<sub>EE</sub>, V<sub>IHCMR</sub> max varies 1:1 with V<sub>CC</sub>. The V<sub>IHCMR</sub> range is referenced to the most positive side of the differential input signal.

# NB100ELT23L

**Table 5. TTL DC CHARACTERISTICS**  $V_{CC} = 3.3\text{ V}$ ,  $GND = 0.0\text{ V}$ ,  $T_A = -40^\circ\text{C}$  to  $85^\circ\text{C}$

| Symbol   | Characteristic               | Condition                 | Min  | Typ | Max | Unit |
|----------|------------------------------|---------------------------|------|-----|-----|------|
| $V_{OH}$ | Output HIGH Voltage          | $I_{OH} = -3.0\text{ mA}$ | 2.4  |     |     | V    |
| $V_{OL}$ | Output LOW Voltage           | $I_{OL} = 24\text{ mA}$   |      |     | 0.5 | V    |
| $I_{OS}$ | Output Short Circuit Current |                           | -180 |     | -50 | mA   |

NOTE: Device will meet the specifications after thermal equilibrium has been established when mounted in a test socket or printed circuit board with maintained transverse airflow greater than 500 lfm.

**Table 6. AC CHARACTERISTICS**  $V_{CC} = 3.3\text{ V} \pm 5\%$ ,  $GND = 0.0\text{ V}$  (Note 4)

| Symbol                                 | Characteristic   | -40°C      |     |                 | 25°C       |     |                 | 85°C       |     |                 | Unit |
|--|--|------------|-----|-----------------|------------|-----|-----------------|------------|-----|-----------------|------|
|  |  | Min        | Typ | Max             | Min        | Typ | Max             | Min        | Typ | Max             |      |
| $f_{max}$                              | Maximum Frequency  | 160        |     |                 | 160        |     |                 | 160        |     |                 | MHz  |
| $t_{PLH}$ ,<br>$t_{PHL}$               | Propagation Delay to Output Differential<br>(Note 5)<br>$C_L = 20\text{ pF}$     | 1.55       | 1.9 | 2.95            | 1.55       | 1.9 | 2.95            | 1.55       | 1.9 | 3.25            | ns   |
| $t_{SK++}$<br>$t_{SK--}$<br>$t_{SKPP}$ | Output-to-Output Skew++<br>Output-to-Output Skew--<br>Part-to-Part Skew (Note 6) |            |     | 60<br>25<br>500 |            |     | 60<br>25<br>500 |            |     | 60<br>25<br>500 | ps   |
| $t_{JITTER}$                           | Random Clock Jitter (RMS)  |            | 6.0 | 20              |            | 6.0 | 20              |            | 6.0 | 20              | ps   |
| $V_{PP}$                               | Input Voltage Swing<br>(Differential Configuration)                              | 150        | 800 | 1200            | 150        | 800 | 1200            | 150        | 800 | 1200            | mV   |
| $t_r$<br>$t_f$                         | Output Rise/Fall Times<br>$C_L = 20\text{ pF}$ (0.8 V to 2.0 V)                  | 700<br>300 | 900 | 1700<br>1250    | 700<br>300 | 900 | 1700<br>1250    | 700<br>300 | 900 | 1700<br>1250    | ps   |

NOTE: Device will meet the specifications after thermal equilibrium has been established when mounted in a test socket or printed circuit board with maintained transverse airflow greater than 500 lfm.

4. Measured using a 750 mV source, 50% duty cycle clock source. All loading with  $500\ \Omega$  to GND,  $C_L = 20\text{ pF}$ .
5. Reference ( $V_{CC} = 3.3\text{ V} \pm 5\%$ ;  $GND = 0\text{ V}$ ).
6. Skews are measured between outputs under identical conditions.

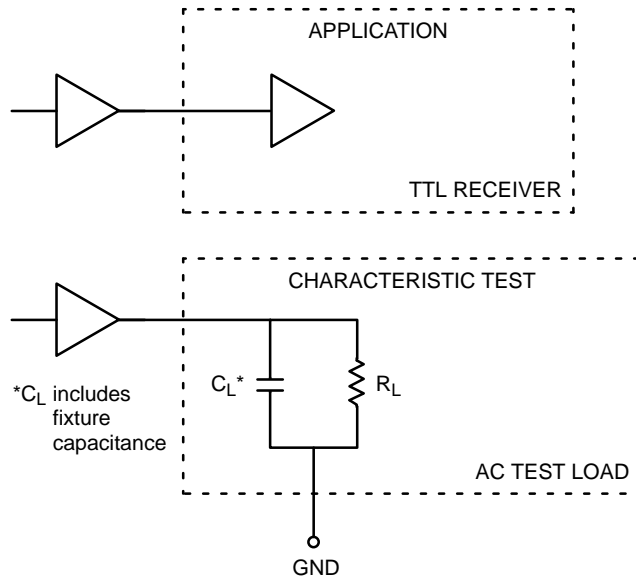

**Figure 2. TTL Output Loading Used for Device Evaluation**

# NB100ELT23L

## ORDERING INFORMATION

| Device           | Package              | Shipping†          |
|------------------|----------------------|--------------------|
| NB100ELT23LDG    | SO-8<br>(Pb-Free)    | 98 Units / Rail    |
| NB100ELT23LDR2G  | SO-8<br>(Pb-Free)    | 2500 / Tape & Reel |
| NB100ELT23LDTG   | TSSOP-8<br>(Pb-Free) | 100 Units / Rail   |
| NB100ELT23LDTR2G | TSSOP-8<br>(Pb-Free) | 2500 / Tape & Reel |

†For information on tape and reel specifications, including part orientation and tape sizes, please refer to our Tape and Reel Packaging Specifications Brochure, BRD8011/D.

### Resource Reference of Application Notes

- AN1405/D** – ECL Clock Distribution Techniques
- AN1406/D** – Designing with PECL (ECL at +5.0 V)
- AN1503/D** – ECLinPS™ I/O SPiCE Modeling Kit
- AN1504/D** – Metastability and the ECLinPS Family
- AN1568/D** – Interfacing Between LVDS and ECL
- AN1672/D** – The ECL Translator Guide
- AND8001/D** – Odd Number Counters Design
- AND8002/D** – Marking and Date Codes
- AND8020/D** – Termination of ECL Logic Devices
- AND8066/D** – Interfacing with ECLinPS
- AND8090/D** – AC Characteristics of ECL Devices

# NB100ELT23L

## PACKAGE DIMENSIONS

SOIC-8 NB  
CASE 751-07  
ISSUE AK

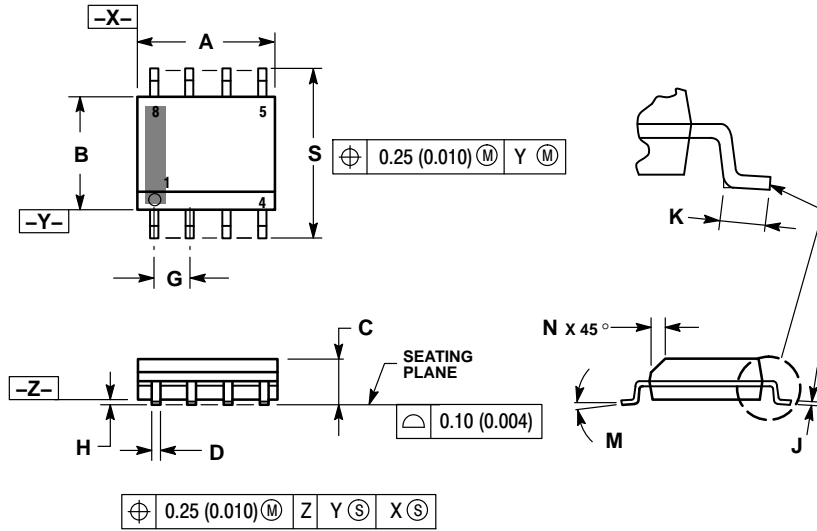

**NOTES:**

1. DIMENSIONING AND TOLERANCING PER ANSI Y14.5M, 1982.
2. CONTROLLING DIMENSION: MILLIMETER.
3. DIMENSION A AND B DO NOT INCLUDE MOLD PROTRUSION.
4. MAXIMUM MOLD PROTRUSION 0.15 (0.006) PER SIDE.
5. DIMENSION D DOES NOT INCLUDE DAMBAR PROTRUSION. ALLOWABLE DAMBAR PROTRUSION SHALL BE 0.127 (0.005) TOTAL IN EXCESS OF THE D DIMENSION AT MAXIMUM MATERIAL CONDITION.
6. 751-01 THRU 751-06 ARE OBSOLETE. NEW STANDARD IS 751-07.

| DIM | MILLIMETERS |      | INCHES    |       |
|-----|-------------|------|-----------|-------|
|     | MIN         | MAX  | MIN       | MAX   |
| A   | 4.80        | 5.00 | 0.189     | 0.197 |
| B   | 3.80        | 4.00 | 0.150     | 0.157 |
| C   | 1.35        | 1.75 | 0.053     | 0.069 |
| D   | 0.33        | 0.51 | 0.013     | 0.020 |
| G   | 1.27 BSC    |      | 0.050 BSC |       |
| H   | 0.10        | 0.25 | 0.004     | 0.010 |
| J   | 0.19        | 0.25 | 0.007     | 0.010 |
| K   | 0.40        | 1.27 | 0.016     | 0.050 |
| M   | 0 °         | 8 °  | 0 °       | 8 °   |
| N   | 0.25        | 0.50 | 0.010     | 0.020 |
| S   | 5.80        | 6.20 | 0.228     | 0.244 |

### SOLDERING FOOTPRINT\*

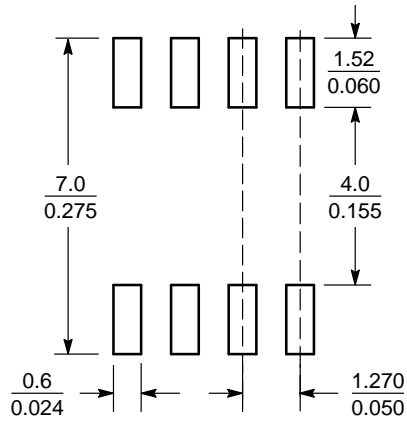

SCALE 6:1  $\left(\frac{\text{mm}}{\text{inches}}\right)$

\*For additional information on our Pb-Free strategy and soldering details, please download the ON Semiconductor Soldering and Mounting Techniques Reference Manual, SOLDERRM/D.

# NB100ELT23L

## PACKAGE DIMENSIONS

TSSOP-8  
DT SUFFIX  
CASE 948R-02  
ISSUE A

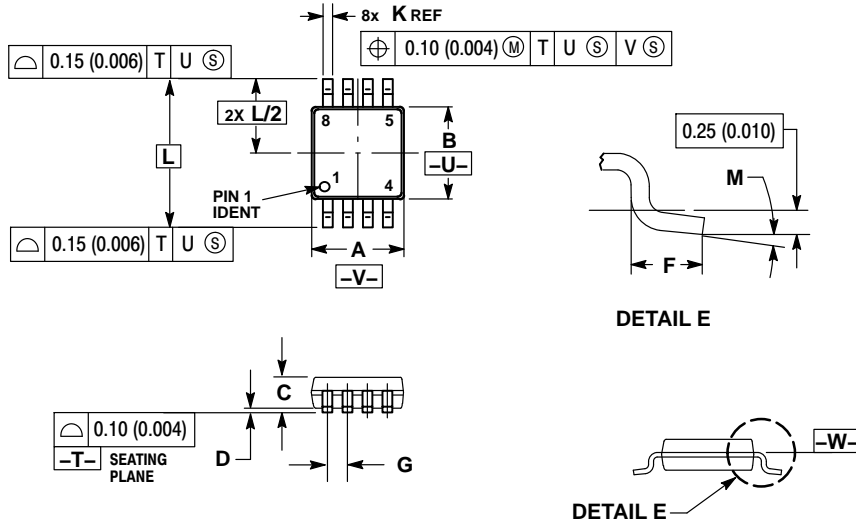

- NOTES:
1. DIMENSIONING AND TOLERANCING PER ANSI Y14.5M, 1982.
  2. CONTROLLING DIMENSION: MILLIMETER.
  3. DIMENSION A DOES NOT INCLUDE MOLD FLASH. PROTRUSIONS OR GATE BURRS. MOLD FLASH OR GATE BURRS SHALL NOT EXCEED 0.15 (0.006) PER SIDE.
  4. DIMENSION B DOES NOT INCLUDE INTERLEAD FLASH OR PROTRUSION. INTERLEAD FLASH OR PROTRUSION SHALL NOT EXCEED 0.25 (0.010) PER SIDE.
  5. TERMINAL NUMBERS ARE SHOWN FOR REFERENCE ONLY.
  6. DIMENSION A AND B ARE TO BE DETERMINED AT DATUM PLANE -W-.

| DIM | MILLIMETERS |      | INCHES    |       |
|-----|-------------|------|-----------|-------|
|     | MIN         | MAX  | MIN       | MAX   |
| A   | 2.90        | 3.10 | 0.114     | 0.122 |
| B   | 2.90        | 3.10 | 0.114     | 0.122 |
| C   | 0.80        | 1.10 | 0.031     | 0.043 |
| D   | 0.05        | 0.15 | 0.002     | 0.006 |
| F   | 0.40        | 0.70 | 0.016     | 0.028 |
| G   | 0.65 BSC    |      | 0.026 BSC |       |
| K   | 0.25        | 0.40 | 0.010     | 0.016 |
| L   | 4.90 BSC    |      | 0.193 BSC |       |
| M   | 0°          | 6°   | 0°        | 6°    |

ECLinPS is a trademark of Semiconductor Components Industries, LLC (SCILLC).

ON Semiconductor and the are registered trademarks of Semiconductor Components Industries, LLC (SCILLC) or its subsidiaries in the United States and/or other countries. SCILLC owns the rights to a number of patents, trademarks, copyrights, trade secrets, and other intellectual property. A listing of SCILLC's product/patent coverage may be accessed at [www.onsemi.com/site/pdf/Patent-Marking.pdf](http://www.onsemi.com/site/pdf/Patent-Marking.pdf). SCILLC reserves the right to make changes without further notice to any products herein. SCILLC makes no warranty, representation or guarantee regarding the suitability of its products for any particular purpose, nor does SCILLC assume any liability arising out of the application or use of any product or circuit, and specifically disclaims any and all liability, including without limitation special, consequential or incidental damages. "Typical" parameters which may be provided in SCILLC data sheets and/or specifications can and do vary in different applications and actual performance may vary over time. All operating parameters, including "Typicals" must be validated for each customer application by customer's technical experts. SCILLC does not convey any license under its patent rights nor the rights of others. SCILLC products are not designed, intended, or authorized for use as components in systems intended for surgical implant into the body, or other applications intended to support or sustain life, or for any other application in which the failure of the SCILLC product could create a situation where personal injury or death may occur. Should Buyer purchase or use SCILLC products for any such unintended or unauthorized application, Buyer shall indemnify and hold SCILLC and its officers, employees, subsidiaries, affiliates, and distributors harmless against all claims, costs, damages, and expenses, and reasonable attorney fees arising out of, directly or indirectly, any claim of personal injury or death associated with such unintended or unauthorized use, even if such claim alleges that SCILLC was negligent regarding the design or manufacture of the part. SCILLC is an Equal Opportunity/Affirmative Action Employer. This literature is subject to all applicable copyright laws and is not for resale in any manner.

### PUBLICATION ORDERING INFORMATION

**LITERATURE FULFILLMENT:**  
Literature Distribution Center for ON Semiconductor  
19521 E. 32nd Pkwy, Aurora, Colorado 80011 USA  
Phone: 303-675-2175 or 800-344-3860 Toll Free USA/Canada  
Fax: 303-675-2176 or 800-344-3867 Toll Free USA/Canada  
Email: [orderlit@onsemi.com](mailto:orderlit@onsemi.com)



**N. American Technical Support:** 800-282-9855 Toll Free  
USA/Canada  
**Europe, Middle East and Africa Technical Support:**  
Phone: 421 33 790 2910  
**Japan Customer Focus Center**  
Phone: 81-3-5817-1050

**ON Semiconductor Website:** [www.onsemi.com](http://www.onsemi.com)  
**Order Literature:** <http://www.onsemi.com/orderlit>

For additional information, please contact your local Sales Representative

## Looking for pricing, stock, or lifecycle information?

Click below to explore more details on WIN SOURCE:

-  [View NB100ELT23LDTG on WIN SOURCE](#)
-  [ON Semiconductor Information](#)

## Optimize Your Supply Chain with WIN SOURCE Solutions

-  Global Sourcing Solution
-  Obsolete Management
-  Cost Control Management
-  Shortage Management
-  Alternative Solution
-  Excess Inventory Management