



**THE DATASHEET OF
WCT-5W1COILTX**





Consumer, Industrial

Freescale Single-Coil Wireless Charger Reference Design

Exceptional performance at a low cost

Target Applications

- 5 W single-coil wireless charging applications
- Mobile phone chargers
- Point-of-sale terminals
- Handheld medical devices
- Mobile phone accessories such as battery banks and active phone sleeves
- PC accessories, including keyboards and mice

Overview

The 5W1COILT is a 5 W single-coil transmitter reference design based on the Freescale MWCT1000CFM wireless charging IC. The Freescale 5 W single-coil transmitter provides what engineers need most: high performance at low cost. The reference design provides the highest efficiency and active charging area available while maintaining the most cost competitive electronic bill of materials (BOM).

The design is based on the Wireless Power Consortium (WPC) A11 transmitter definition, comprising of a 5 V DC input source, full-bridge inverter topology and frequency control methodology. Freescale extends support to any coil topology which uses a 5 V input source; therefore, this reference design currently supports A11, A12 and A16 coil configurations on a single platform, as well as any future single coil design. This reduces the need for different hardware to support multiple (and future) coil types with similar characteristics.

WCT-5W1COILT Single-Coil Wireless Charger Block Diagram

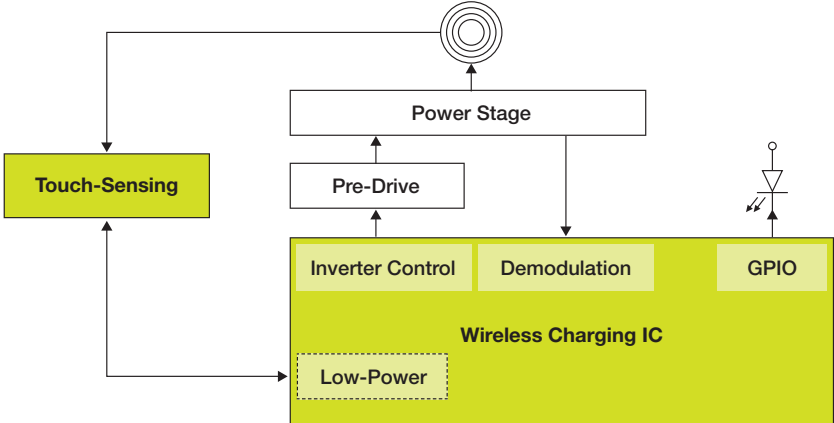

■ Freescale Technology □ Optional



Additionally, the 5W1 COILTX reference design uses Freescale's innovative wireless charging transmit controller to perform digital demodulation on incoming communication from the receiver. This unique feature provides a major reduction in BOM costs and the added benefit of a reduced PCB footprint. Another feature is robust foreign object detection (FOD) algorithm. This feature detects metallic objects such as aluminum or steel objects that may be present in the charging environment. Freescale foreign object detection algorithms easily meet and exceed the latest standards within industry.

Ultimately, the 5W1 COILTX reference design is a complete system solution, containing all of the hardware and software components necessary to quickly implement a single-coil charger solution. Freescale provides all of the necessary hardware documentation, including schematics, layout and assembly files as well as a complete BOM. A firmware library is provided which contains all of the necessary wireless charging control blocks. Access to the library is provided via an API which lets users interact with parameters and settings contained in the firmware, providing maximum control to the engineer. Customers can choose to use a ready-to-use binary file provided by Freescale or to take a more developmental approach and build an application around the firmware library.

Features

Features	Benefits
Compliant with latest WPC Qi specification	Ensure end solution meets latest industry specification
Transfer efficiency greater than 75%	Maximum energy transfer and lower thermal footprint
Meets latest FOD requirements	Ensure foreign objects are detected and provides safety function
Supports most 5 W single-coil type using 5 V power source	Provides a broad range of magnetics support with a single solution
Main controller IC provides low active RUN power (30mA)	Increase overall operating efficiency
Less than 30 mW standby power consumption (using Freescale proximity detection technology)	Lowest standby operating mode
Support for current limited power sources	Operate from PC-based power sources
SPI, UART, I ² C communication interfaces	Communicate to and from wireless charging IC to transfer charging information (MWCT1101CLH only)
On-chip digital demodulation	Lower system BOM and greater performance
Run-time calibration	Fast and accurate system calibration, saving time and effort to optimize system performance
WPC A11, A12, A16 support	Extend support for any defined 5 V single-coil application
WCT firmware library	Choose as-is firmware or build value-added features onto existing library

Package Options

Part Number	Package	Available Flash Size	Key Features
MWCT1000CFM	32-pin QFN	NA	Complete controller solution, support most Qi 5 W single coils
MWCT1101CLH	64-pin LQFP	40 KB	Premium controller, I ² C, UART, SPI, flash memory for application programming

Development Tools

WCT-5W1COILTX

BOM-cost optimized single-coil 5 W reference design for any type of closely coupled inductive charging application

Eclipse™-based CodeWarrior Development Studio for Microcontrollers

A complete integrated development environment (IDE) that provides a highly visual and automated framework to accelerate the development of the most complex embedded applications

WCTGUI

Graphical user interface tool for quickly configuring and optimizing wireless charging transmitter solutions

For more information, visit freescale.com/WCT-5W1COILTX

Looking for pricing, stock, or lifecycle information?

Click below to explore more details on WIN SOURCE:

- ⊖ [View WCT-5W1COILTX on WIN SOURCE](#)
- ⊖ [NXP / Nexperia Information](#)

Optimize Your Supply Chain with WIN SOURCE Solutions

- ✓ Global Sourcing Solution
- ✓ Obsolete Management
- ✓ Cost Control Management
- ✓ Shortage Management
- ✓ Alternative Solution
- ✓ Excess Inventory Management