

NAND Flash Memory

MT29F4G08AAA, MT29F8G08BAA, MT29F8G08DAA, MT29F16G08FAA

Features

- Single-level cell (SLC) technology
- Organization
 - Page size x8: 2,112 bytes (2,048 + 64 bytes)
 - Block size: 64 pages (128K + 4K bytes)
 - Plane size: 2,048 blocks
 - Device size: 4Gb: 4,096 blocks; 8Gb: 8,192 blocks; 16Gb: 16,384 blocks
- READ performance
 - Random READ: 25µs (MAX)
 - Sequential READ: 25ns (MIN)
- WRITE performance
 - PROGRAM PAGE: 220µs (TYP)
 - BLOCK ERASE: 1.5ms (TYP)
- Data retention: 10 years
- Endurance: 100,000 PROGRAM/ERASE cycles
- First block (block address 00h) guaranteed to be valid up to 1,000 PROGRAM/ERASE cycles¹
- Industry-standard basic NAND Flash command set
- Advanced command set:
 - PROGRAM PAGE CACHE MODE
 - PAGE READ CACHE MODE
 - One-time programmable (OTP) commands
 - Two-plane commands
 - Interleaved die operations
 - READ UNIQUE ID (contact factory)
 - READ ID2 (contact factory)
- Operation status byte provides a software method of detecting:
 - Operation completion
 - Pass/fail condition
 - Write-protect status
- Ready/busy# (R/B#) signal provides a hardware method of detecting operation completion
- WP# signal: write protect entire device
- RESET required after power-up
- INTERNAL DATA MOVE operations supported within the plane from which data is read

Figure 1: 48-Pin TSOP Type 1

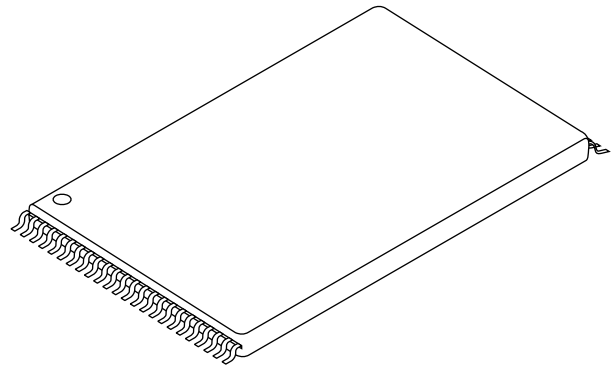

Options

- Density²
 - 4Gb (single die)
 - 8Gb (dual-die stack 1 CE#)
 - 8Gb (dual-die stack 2 CE#)
 - 16Gb (quad-die stack)
- Device width: x8
- Configuration

# of die	# of CE#	# of R/B#	I/O
1	1	1	Common
2	1	1	Common
2	2	2	Common
4	2	2	Common
- VCC: 2.7–3.6V
- Package
 - 48 TSOP type I (lead-free plating)
 - 48 TSOP type I OCPL³ (lead-free plating)
- Operating temperature
 - Commercial (0°C to +70°C)
 - Extended (–40°C to +85°C)⁴

- Notes: 1. For further details, see “Error Management” on page 58.
2. For part numbering and markings, see Figure 2 on page 2.
3. OCPL = off-center parting line.
4. For ET devices, contact factory.

Part Numbering Information

Micron® NAND Flash devices are available in several different configurations and densities (see Figure 2).

Figure 2: Part Number Chart

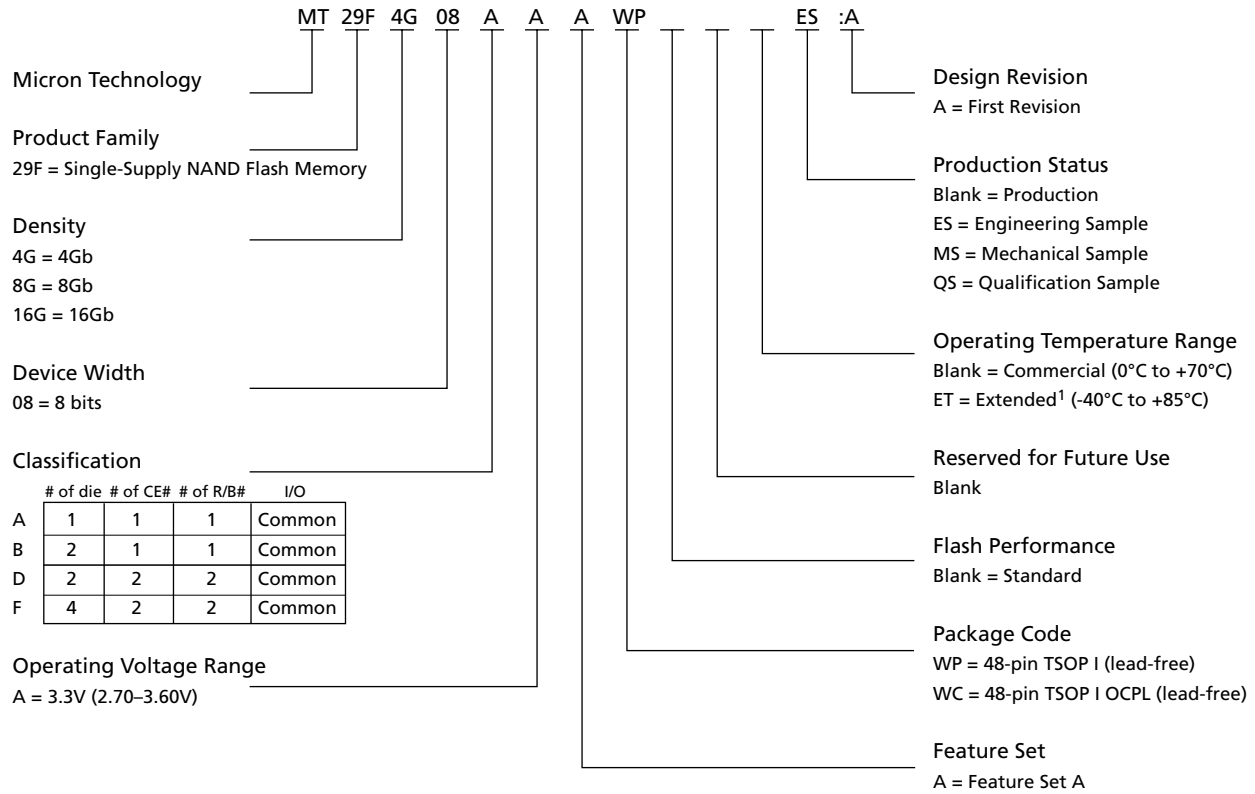

Notes: 1. For ET devices, contact factory.

Valid Part Number Combinations

After building the part number from the part numbering chart, verify that the part number is offered and valid by using the Micron Parametric Part Search Web site at www.micron.com/products/parametric. If the device required is not on this list, contact the factory.

Table of Contents

Features	1
Part Numbering Information	2
Valid Part Number Combinations	2
General Description	8
Architecture	11
Addressing	12
Memory Mapping	12
Array Organization	13
Bus Operation	15
Control Signals	15
Commands	15
Address Input	15
Data Input	16
READs	16
Ready/Busy#	16
Command Definitions	19
READ Operations	21
PAGE READ 00h-30h	21
RANDOM DATA READ 05h-E0h	22
PAGE READ CACHE MODE START 31h; PAGE READ CACHE MODE START LAST 3Fh	22
READ ID 90h	24
READ STATUS 70h	26
PROGRAM Operations	27
PROGRAM PAGE 80h-10h	27
SERIAL DATA INPUT 80h	27
RANDOM DATA INPUT 85h	27
PROGRAM PAGE CACHE MODE 80h-15h	28
Internal Data Move	29
READ FOR INTERNAL DATA MOVE 00h-35h	29
PROGRAM for INTERNAL DATA MOVE 85h-10h	29
BLOCK ERASE Operation	30
BLOCK ERASE 60h-D0h	30
One-Time Programmable (OTP) Area	31
OTP DATA PROGRAM A0h-10h	32
OTP DATA PROTECT A5h-10h	34
OTP DATA READ AFh-30h	34
TWO-PLANE Operations	35
Two-Plane Addressing	35
TWO-PLANE PAGE READ 00h-00h-30h	36
TWO-PLANE RANDOM DATA READ 06h-E0h	36
TWO-PLANE PROGRAM PAGE 80h-11h-80h-10h	39
TWO-PLANE PROGRAM PAGE CACHE MODE 80h-11h-80h-15h	40
TWO-PLANE INTERNAL DATA MOVE 00h-00h-35h/85h-11h-80h-10h	42
TWO-PLANE READ for INTERNAL DATA MOVE 00h-00h-35h	42
TWO-PLANE PROGRAM for INTERNAL DATA MOVE 85h-11h-80h-10h	43
TWO-PLANE BLOCK ERASE 60h-60h-D0h	45
TWO-PLANE/MULTIPLE-DIE READ STATUS 78h	46
Interleaved Die Operations	47
Interleaved PROGRAM PAGE Operations	47
Interleaved PROGRAM PAGE CACHE MODE Operations	48
Interleaved TWO-PLANE PROGRAM PAGE Operations	49
Interleaved TWO-PLANE PROGRAM PAGE CACHE MODE Operations	52
Interleaved BLOCK ERASE Operations	54
Interleaved TWO-PLANE BLOCK ERASE Operations	54
RESET Operation	56
RESET FFh	56



4Gb, 8Gb, and 16Gb x8 NAND Flash Memory Table of Contents

WRITE PROTECT Operation57
Error Management58
Electrical Characteristics59
VCC Power Cycling60
Timing Diagrams65
Package Dimensions79

List of Figures

Figure 1: 48-Pin TSOP Type 1 1
 Figure 2: Part Number Chart 2
 Figure 3: 48-Pin TSOP Type 1 Pin Assignment (Top View) 9
 Figure 4: NAND Flash Functional Block Diagram 11
 Figure 5: Memory Map 12
 Figure 6: Array Organization for MT29F4G08AAA and MT29F8G08DAA (x8) 13
 Figure 7: Array Organization for MT29F8G08BAA and MT29F16G08FAA (x8) 14
 Figure 8: READY/BUSY# Open Drain 17
 Figure 9: tFall and tRise 17
 Figure 10: Iol vs. Rp 18
 Figure 11: TC vs. Rp 18
 Figure 12: PAGE READ Operation 21
 Figure 13: RANDOM DATA READ Operation 22
 Figure 14: PAGE READ CACHE MODE Operation 23
 Figure 15: READ ID Operation 24
 Figure 16: Status Register Operation 27
 Figure 17: PROGRAM and READ STATUS Operation 28
 Figure 18: RANDOM DATA INPUT Operation 28
 Figure 19: PROGRAM PAGE CACHE MODE Operation Example 29
 Figure 20: INTERNAL DATA MOVE Operation 30
 Figure 21: INTERNAL DATA MOVE Operation with RANDOM DATA INPUT 30
 Figure 22: BLOCK ERASE Operation 31
 Figure 23: OTP DATA PROGRAM Operation 33
 Figure 24: OTP DATA PROTECT Operation 34
 Figure 25: OTP DATA READ Operation 35
 Figure 26: TWO-PLANE PAGE READ Operation 37
 Figure 27: TWO-PLANE PAGE READ Operation with RANDOM DATA READ 38
 Figure 28: TWO-PLANE PROGRAM PAGE Operation 39
 Figure 29: TWO-PLANE PROGRAM PAGE Operation with RANDOM DATA INPUT 40
 Figure 30: TWO-PLANE PROGRAM PAGE CACHE MODE Operation 42
 Figure 31: TWO-PLANE INTERNAL DATA MOVE Operation 44
 Figure 32: TWO-PLANE INTERNAL DATA MOVE Operation with RANDOM DATA INPUT 44
 Figure 33: TWO-PLANE BLOCK ERASE Operation 45
 Figure 34: TWO-PLANE/MULTIPLE-DIE READ STATUS Cycle 46
 Figure 35: Interleaved PROGRAM PAGE Operation with R/B# Monitoring 47
 Figure 36: Interleaved PROGRAM PAGE Operation with Status Register Monitoring 48
 Figure 37: Interleaved PROGRAM PAGE CACHE MODE Operation with R/B# Monitoring 48
 Figure 38: Interleaved PROGRAM PAGE CACHE MODE Operation with Status Register Monitoring 49
 Figure 39: Interleaved TWO-PLANE PROGRAM PAGE Operation with R/B# Monitoring 50
 Figure 40: Interleaved TWO-PLANE PROGRAM PAGE Operation with Status Register Monitoring 51
 Figure 41: Interleaved TWO-PLANE PROGRAM PAGE CACHE MODE Operation with R/B# Monitoring 52
 Figure 42: Interleaved TWO-PLANE PROGRAM PAGE CACHE MODE Operation with Status Register Monitoring 53
 Figure 43: Interleaved BLOCK ERASE Operation with R/B# Monitoring 54
 Figure 44: Interleaved BLOCK ERASE Operation with Status Register Monitoring 54
 Figure 45: Interleaved TWO-PLANE BLOCK ERASE Operation with R/B# Monitoring 55
 Figure 46: Interleaved TWO-PLANE BLOCK ERASE Operation with Status Register Monitoring 55
 Figure 47: RESET Operation 56
 Figure 48: ERASE Enable 57
 Figure 49: ERASE Disable 57
 Figure 50: PROGRAM Enable 57
 Figure 51: PROGRAM Disable 58
 Figure 52: AC Waveforms During Power Transitions 60
 Figure 53: COMMAND LATCH Cycle 65
 Figure 54: ADDRESS LATCH Cycle 65
 Figure 55: INPUT DATA LATCH Cycle 66



Figure 56:	SERIAL ACCESS Cycle After READ	.66
Figure 57:	SERIAL ACCESS Cycle After READ (EDO Mode)	.67
Figure 58:	READ STATUS Operation	.67
Figure 59:	TWO-PLANE/MULTIPLE-DIE READ STATUS Operation	.68
Figure 60:	PAGE READ Operation	.68
Figure 61:	READ Operation with CE# "Don't Care"	.69
Figure 62:	RANDOM DATA READ Operation	.69
Figure 63:	PAGE READ CACHE MODE Operation, Part 1 of 2	.70
Figure 64:	PAGE READ CACHE MODE Operation, Part 2 of 2	.71
Figure 65:	PAGE READ CACHE MODE Operation without R/B#, Part 1 of 2	.72
Figure 66:	PAGE READ CACHE MODE Operation without R/B#, Part 2 of 2	.73
Figure 67:	READ ID Operation	.74
Figure 68:	PROGRAM PAGE Operation	.74
Figure 69:	Program Operation with CE# "Don't Care"	.75
Figure 70:	PROGRAM PAGE Operation with RANDOM DATA INPUT	.75
Figure 71:	INTERNAL DATA MOVE Operation	.76
Figure 72:	PROGRAM PAGE CACHE MODE Operation	.76
Figure 73:	PROGRAM PAGE CACHE MODE Operation Ending on 15h	.77
Figure 74:	BLOCK ERASE Operation	.78
Figure 75:	RESET Operation	.78
Figure 76:	48-Pin TSOP Type 1 (WP Package Code)	.79
Figure 77:	48-Pin TSOP OCPL Type 1 (WC Package Code)	.80

List of Tables

Table 1:	Signal Descriptions	10
Table 2:	Operational Example	12
Table 3:	Array Addressing: MT29F4G08AAA and MT29F8G08DAA	13
Table 4:	Array Addressing: MT28F8G08BAA and MT29F16G08FAA	14
Table 5:	Mode Selection	18
Table 6:	Command Set	19
Table 7:	Two-Plane Command Set	20
Table 8:	Device ID and Configuration Codes	25
Table 9:	Status Register Bit Definition	26
Table 10:	Status Register Contents After RESET Operation	56
Table 11:	Absolute Maximum Ratings	59
Table 12:	Recommended Operating Conditions	59
Table 13:	M29FxGxxxAA 3V Device DC and Operating Characteristics	61
Table 14:	Valid Blocks	61
Table 15:	Capacitance	62
Table 16:	Test Conditions	62
Table 17:	AC Characteristics: Command, Data, and Address Input	62
Table 18:	AC Characteristics: Normal Operation	63
Table 19:	PROGRAM/ERASE Characteristics	64

General Description

NAND Flash technology provides a cost-effective solution for applications requiring high-density, solid-state storage. The MT29F4G08AAA is a 4Gb NAND Flash memory device. The MT29F8G08BAA is a two-die stack that operates as a single 8Gb device. The MT29F8G08DAA is a two-die stack that operates as two independent 4Gb devices. The MT29F16G08FAA is a four-die stack that operates as two independent 8Gb devices, providing a total storage capacity of 16Gb in a single, space-saving package. Micron NAND Flash devices include standard NAND Flash features as well as new features designed to enhance system-level performance.

Micron NAND Flash devices use a highly multiplexed 8-bit bus (I/O[7:0]) to transfer data, addresses, and instructions. The five command pins (CLE, ALE, CE#, RE#, WE#) implement the NAND Flash command bus interface protocol. Additional pins control hardware write protection (WP#) and monitor device status (R/B#).

This hardware interface creates a low-pin-count device with a standard pinout that is the same from one density to another, allowing future upgrades to higher densities without board redesign.

The MT29F4G, MT29F8G, and MT29F16G devices contain two planes per die. Each plane consists of 2,048 blocks. Each block is subdivided into 64 programmable pages. Each page consists of 2,112 bytes. The pages are further divided into a 2,048-byte data storage region with a separate 64-byte area. The 64-byte area is typically used for error management functions.

The contents of each page can be programmed in 220 μ s (TYP), and an entire block can be erased in 1.5ms (TYP). On-chip control logic automates PROGRAM and ERASE operations to maximize cycle endurance. PROGRAM/ERASE endurance is specified at 100,000 cycles with appropriate error correction code (ECC) and error management.

Figure 3: 48-Pin TSOP Type 1 Pin Assignment (Top View)

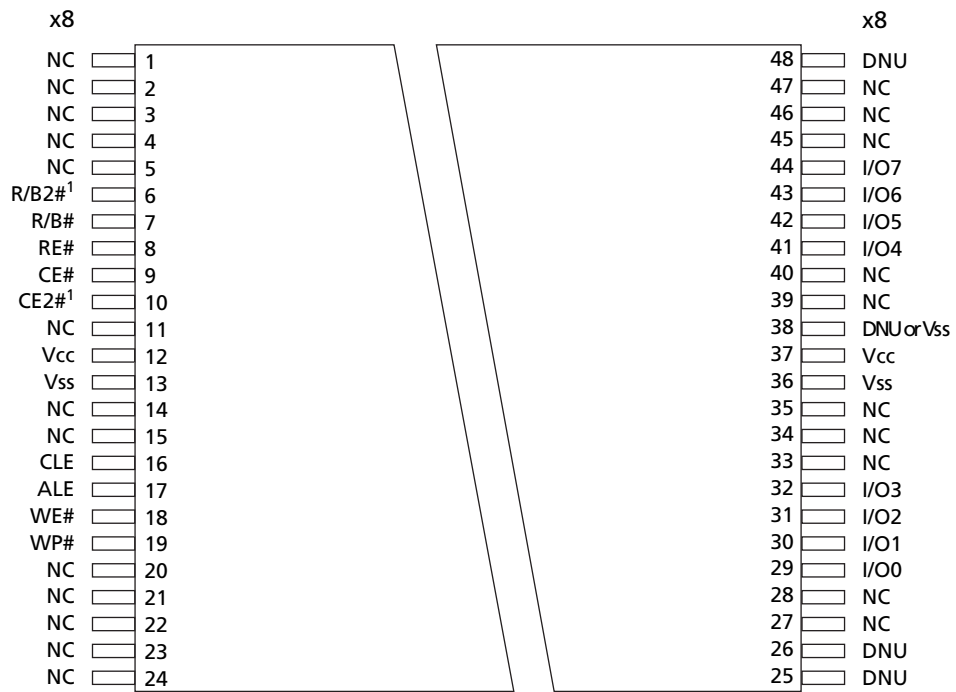

Notes: 1. CE2# and R/B2# are available on 8Gb 2-CE# devices and 16Gb devices only. These pins are NC for other configurations.

Table 1: Signal Descriptions

Symbol	Type	Description
ALE	Input	Address latch enable: During the time ALE is HIGH, address information is transferred from I/O[7:0] into the on-chip address register on the rising edge of WE#. When address information is not being loaded, ALE should be driven LOW.
CE#, CE2#	Input	Chip enable: Gates transfers between the host system and the NAND Flash device. After the device starts a PROGRAM or ERASE operation, CE# can be de-asserted. For the 8Gb configuration, CE# controls the first 4Gb of memory; CE2# controls the second 4Gb of memory. For the 16Gb configuration, CE# controls the first 8Gb of memory; CE2# controls the second 8Gb. See "Bus Operation" on page 15 for additional operational details.
CLE	Input	Command latch enable: When CLE is HIGH, information is transferred from I/O[7:0] to the on-chip command register on the rising edge of WE#. When command information is not being loaded, CLE should be driven LOW.
RE#	Input	Read enable: Gates transfers from the NAND Flash device to the host system.
WE#	Input	Write enable: Gates transfers from the host system to the NAND Flash device.
WP#	Input	Write protect: Protects against inadvertent PROGRAM and ERASE operations. All PROGRAM and ERASE operations are disabled when WP# is LOW.
I/O[7:0] (x8)	I/O	Data inputs/outputs: The bidirectional I/Os transfer address, data, and instruction information. Data is output only during READ operations; at other times the I/Os are inputs.
R/B#, R/B2#	Output	Ready/busy: An open-drain, active-LOW output, that uses an external pull-up resistor. R/B# is used to indicate when the chip is processing a PROGRAM or ERASE operation. It is also used during READ operations to indicate when data is being transferred from the array into the serial data register. When these operations have completed, R/B# returns to the High-Z state. In the 8Gb configuration, R/B# is for the 4Gb of memory enabled by CE#; R/B2# is for the 4Gb of memory enabled by CE2#. In the 16Gb configuration, R/B# is for the 8Gb of memory enabled by CE#; R/B2# is for the 8Gb of memory enabled by CE2#.
VCC	Supply	VCC: Power supply.
VSS	Supply	VSS: Ground connection.
NC	–	No connect: NCs are not internally connected. They can be driven or left unconnected.
DNU	–	Do not use: DNUs must be left unconnected.

Architecture

These devices use NAND Flash electrical and command interfaces. Data, commands, and addresses are multiplexed onto the same pins and received by I/O control circuits. This provides a memory device with a low pin count. The commands received at the I/O control circuits are latched by a command register and are transferred to control logic circuits for generating internal signals to control device operations. The addresses are latched by an address register and sent to a row decoder or a column decoder to select a row address or a column address, respectively.

The data are transferred to or from the NAND Flash memory array, byte by byte (x8), through a data register and a cache register. The cache register is closest to I/O control circuits and acts as a data buffer for the I/O data, whereas the data register is closest to the memory array and acts as a data buffer for the NAND Flash memory array operation.

The NAND Flash memory array is programmed and read in page-based operations and is erased in block-based operations. During normal page operations, the data and cache registers are tied together and act as a single register. During cache operations the data and cache registers operate independently to increase data throughput.

These devices also have a status register that reports the status of device operation.

Figure 4: NAND Flash Functional Block Diagram

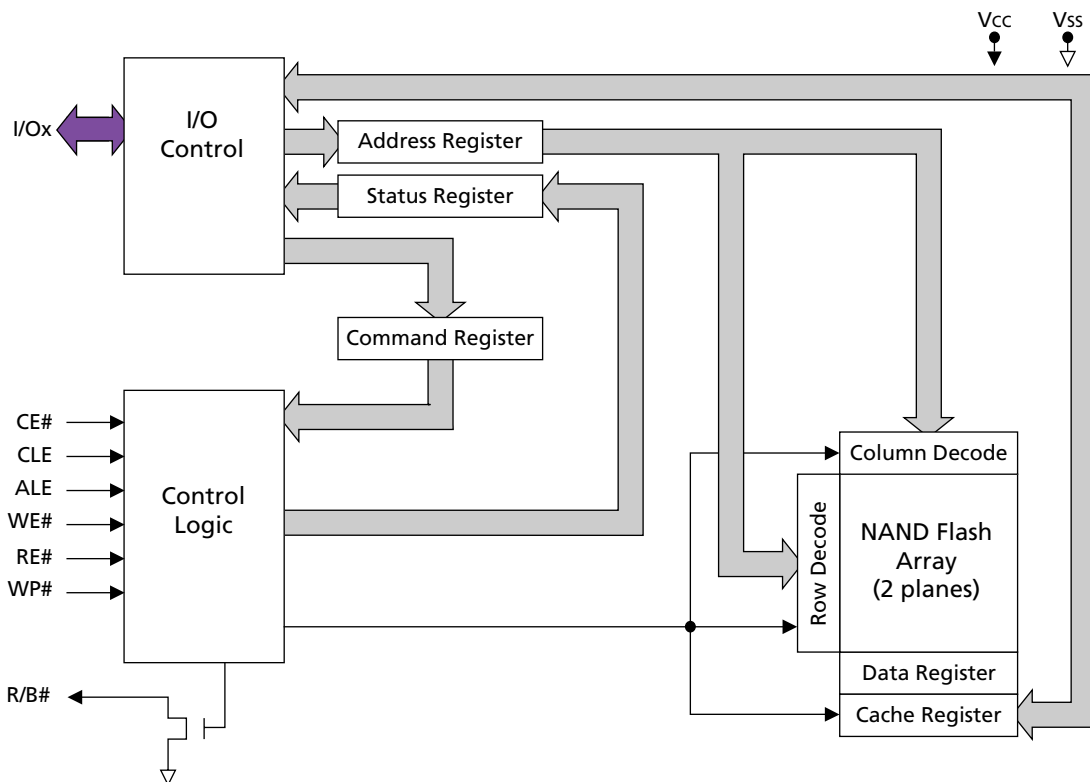

Addressing

NAND Flash devices do not contain dedicated address pins. Addresses are loaded using a 5-cycle sequence as shown in Tables 3 and 4, on pages 13 and 14. See Figure 5 for additional memory mapping and addressing details.

Memory Mapping

Figure 5: Memory Map

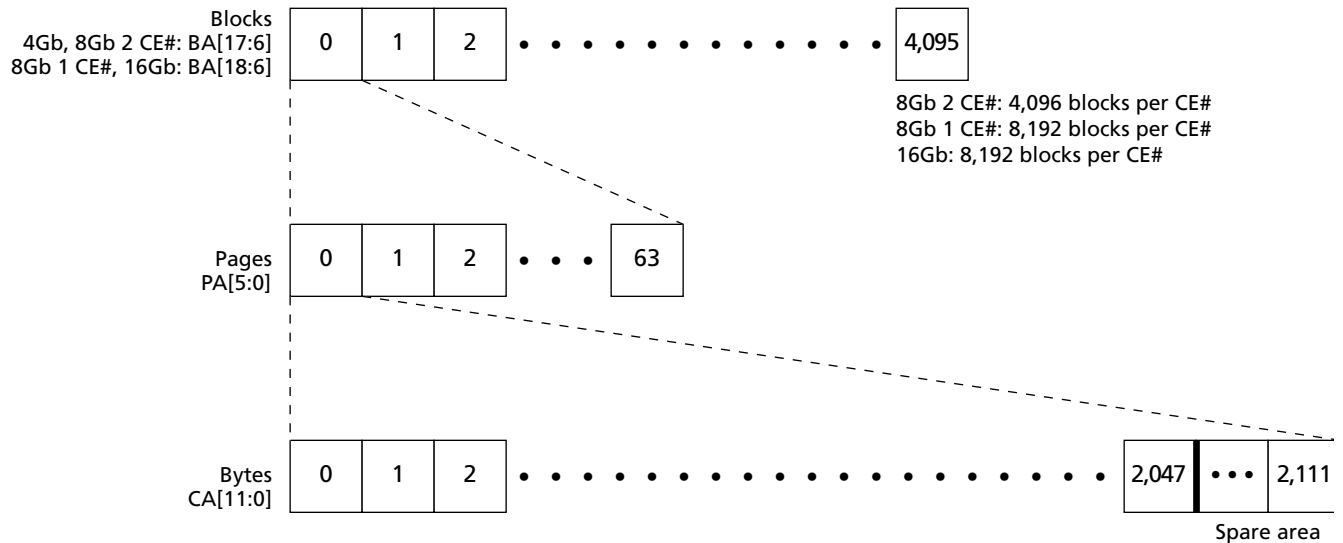

Table 2: Operational Example

Block	Page	Min Address in Page	Max Address in Page	Out of Bounds Addresses in Page
0	0	0x000000000	0x000000083F	0x0000000840–0x0000000FFF
0	1	0x0000010000	0x000001083F	0x0000010840–0x0000010FFF
0	2	0x0000020000	0x000002083F	0x0000020840–0x0000020FFF
...
4,095	62	0x03FFFE0000	0x03FFFE083F	0x03FFFE0840–0x03FFFE0FFF
4,095	63	0x03FFFF0000	0x03FFFF083F	0x03FFFF0840–0x03FFFF0FFF

- Notes:
- As shown in Table 3 on page 13, the high nibble of ADDRESS cycle 2 has no assigned address bits; however, these 4 bits must be held LOW during the ADDRESS cycle to ensure that the address is interpreted correctly by the NAND Flash device. These extra bits are accounted for in ADDRESS cycle 2 even though they do not have address bits assigned to them.
 - The 12-bit column address is capable of addressing from 0 to 4,095 bytes on a x8 device; however, only bytes 0 through 2,111 are valid. Bytes 2,112 through 4,095 of each page are “out of bounds,” do not exist in the device, and cannot be addressed.

Array Organization

Figure 6: Array Organization for MT29F4G08AAA and MT29F8G08DAA (x8)

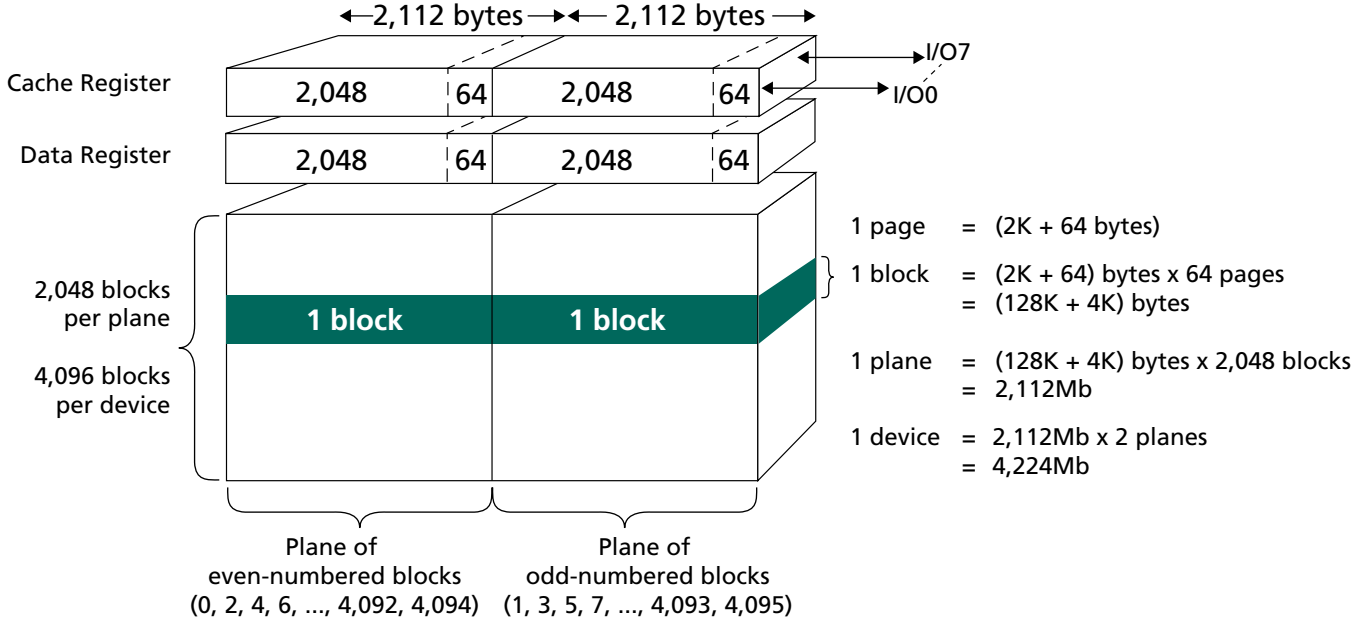

Notes: 1. For the 8Gb MT29F8G08DAA, the 4Gb array organization shown applies to each chip enable (CE# and CE2#).

Table 3: Array Addressing: MT29F4G08AAA and MT29F8G08DAA

Cycle	I/O7	I/O6	I/O5	I/O4	I/O3	I/O2	I/O1	I/O0
First	CA7	CA6	CA5	CA4	CA3	CA2	CA1	CA0
Second	LOW	LOW	LOW	LOW	CA11	CA10	CA9	CA8
Third	BA7	BA6	PA5	PA4	PA3	PA2	PA1	PA0
Fourth	BA15	BA14	BA13	BA12	BA11	BA10	BA9	BA8
Fifth	LOW	LOW	LOW	LOW	LOW	LOW	BA17	BA16

Notes: 1. Block address concatenated with page address = actual page address. CAx = column address; PAx = page address; BAx = block address.
2. If CA11 is "1," then CA[10:6] must be "0."

Figure 7: Array Organization for MT29F8G08BAA and MT29F16G08FAA (x8)

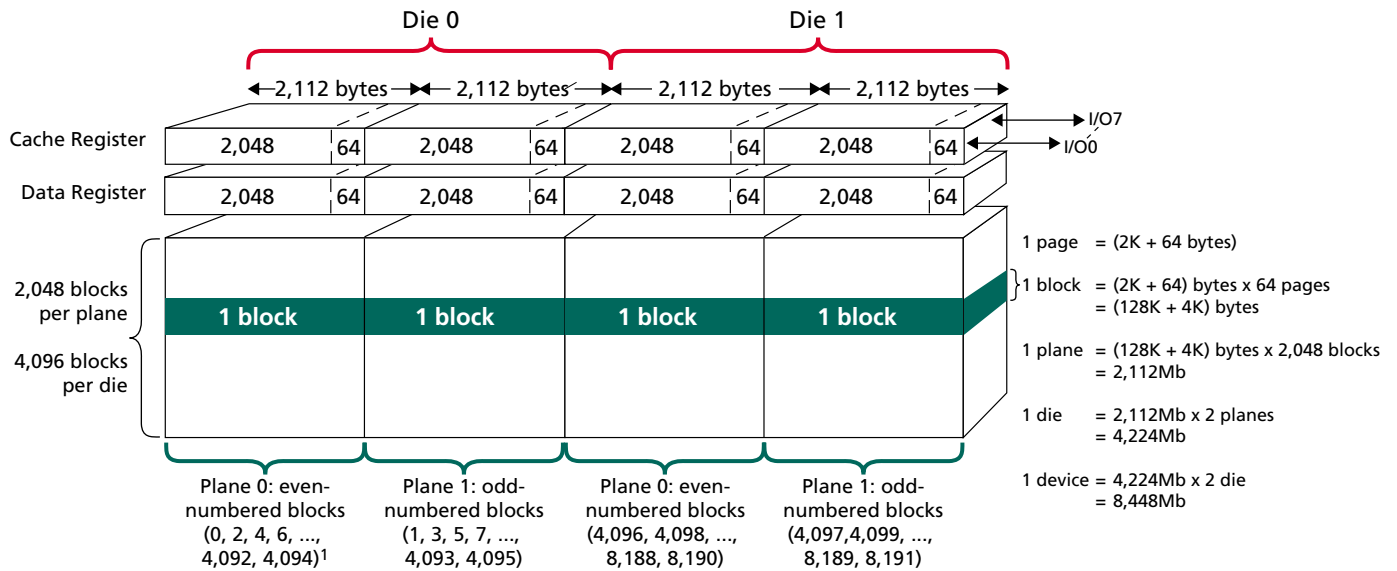

- Notes:
- Die 0, Plane 0: BA18 = 0; BA6 = 0.
Die 0, Plane 1: BA18 = 0; BA6 = 1.
Die 1, Plane 0: BA18 = 1; BA6 = 0.
Die 1, Plane 1: BA18 = 1; BA6 = 1.
 - For the 16Gb MT29F16G08FAA, the 8Gb array organization shown here applies to each chip enable (CE# and CE2#).

Table 4: Array Addressing: MT29F8G08BAA and MT29F16G08FAA

Cycle	I/O7	I/O6	I/O5	I/O4	I/O3	I/O2	I/O1	I/O0
First	CA7	CA6	CA5	CA4	CA3	CA2	CA1	CA0
Second	LOW	LOW	LOW	LOW	CA11	CA10	CA9	CA8
Third	BA7	BA6	PA5	PA4	PA3	PA2	PA1	PA0
Fourth	BA15	BA14	BA13	BA12	BA11	BA10	BA9	BA8
Fifth	LOW	LOW	LOW	LOW	LOW	BA18 ³	BA17	BA16

- Notes:
- Cx = column address; Px = page address; Bx = block address.
 - If CA11 is 1, then CA[10:6] must be "0."
 - Die address boundary: 0 = 0-4Gb; 1 = 4Gb-8Gb.

Bus Operation

The bus on MT29Fxxx devices is multiplexed. Data I/O, addresses, and commands all share the same pins, I/O[7:0].

The command sequence normally consists of a COMMAND LATCH cycle, ADDRESS INPUT cycles, and 1 or more DATA cycles—either READ or WRITE.

Control Signals

CE#, WE#, RE#, CLE, ALE, and WP# control NAND Flash device READ and WRITE operations. On the 8Gb MT29F8G08DAA, CE# and CE2# each control independent 4Gb arrays. On the 16Gb MT29F16G08FAA, CE# and CE2# each control independent 8Gb arrays. CE2# functions the same as CE# for its own array; all operations described for CE# also apply to CE2#.

CE# is used to enable the device. When CE# is LOW and the device is not in the busy state, the NAND Flash memory will accept command, address, and data information.

When the device is not performing an operation, the CE# pin is typically driven HIGH and the device enters standby mode. The memory will enter standby if CE# goes HIGH while data is being transferred and the device is not busy. This helps reduce power consumption. See Figure 61 on page 69 and Figure 69 on page 75 for examples of CE# “Don’t Care” operations.

The CE# “Don’t Care” operation enables the NAND Flash to reside on the same asynchronous memory bus as other Flash or SRAM devices. Other devices on the memory bus can then be accessed while the NAND Flash is busy with internal operations. This capability is important for designs that require multiple NAND Flash devices on the same bus.

A HIGH CLE signal indicates that a command cycle is taking place. A HIGH ALE signal signifies that an ADDRESS INPUT cycle is occurring.

Commands

Commands are written to the command register on the rising edge of WE# when:

- CE# and ALE are LOW, and
- CLE is HIGH, and
- The device is not busy

As exceptions, the device accepts the READ STATUS, TWO-PLANE/MULTIPLE-DIE READ STATUS, and RESET commands when busy. Commands are transferred to the command register on the rising edge of WE# (see Figure 53 on page 65). Commands are input on I/O[7:0].

Address Input

Addresses are written to the address register on the rising edge of WE# when:

- CE# and CLE are LOW, and
- ALE is HIGH

Addresses are input on I/O[7:0]. Bits not part of the address space must be LOW.

The number of ADDRESS cycles required for each command varies. Refer to the command descriptions to determine addressing requirements (see Table 6 on page 19).

Data Input

Data is written to the data register on the rising edge of WE# when:

- CE#, CLE, and ALE are LOW, and
- the device is not busy

Data is input on I/O[7:0]. See Figure 55 on page 66 for additional data input details.

READS

After a READ command is issued, data is transferred from the memory array to the data register on the rising edge of WE#. R/B# goes LOW for ^tR and transitions HIGH after the transfer is complete. When data is available in the data register, it is clocked out of the part by RE# going LOW. See Figure 60 on page 68 for detailed timing information.

The READ STATUS (70h) command, TWO-PLANE/MULTIPLE-DIE READ STATUS (78h) command, or the R/B# signal can be used to determine when the device is ready.

If a controller is using a timing of 30ns or longer for ^tRC, use Figure 56 on page 66 for proper timing. If ^tRC is less than 30ns, use Figure 57 on page 67 for extended data output (EDO) timing.

Ready/Busy#

The R/B# output provides a hardware method of indicating the completion of PROGRAM, ERASE, and READ operations. The signal requires a pull-up resistor for proper operation. The signal is typically HIGH, and transitions to LOW after the appropriate command is written to the device. The signal pin's open-drain driver enables multiple R/B# outputs to be OR-tied. The READ STATUS command can be used in place of R/B#. Typically, R/B# is connected to an interrupt pin on the system controller (see Figure 8 on page 17).

On the 8Gb MT29F8G08DAA, R/B# provides a status indication for the 4Gb section enabled by CE#, and R/B2# does the same for the 4Gb section enabled by CE2#. R/B# and R/B2# can be tied together, or they can be used separately to provide independent indications for each 4Gb section.

On the 16Gb MT29F16G08FAA, R/B# provides a status indication for the 8Gb section enabled by CE#, and R/B2# does the same for the 8Gb section enabled by CE2#. R/B# and R/B2# can be tied together, or they can be used separately to provide independent indications for each 8Gb section.

The combination of R_p and capacitive loading of the R/B# circuit determines the rise time of the R/B# pin. The actual value used for R_p depends on the system timing requirements. Large values of R_p cause R/B# to be delayed significantly. At the 10 to 90 percent points on the R/B# waveform, rise time is approximately two time constants (TC).

$$TC = R \times C$$

Where R = R_p (resistance of pull-up resistor), and C = total capacitive load.

The fall time of the R/B# signal is determined mainly by the output impedance of the R/B# pin and the total load capacitance.

Refer to Figures 10 and 11 on page 18, which depict approximate R_p values using a circuit load of 100pF.

The minimum value for R_p is determined by the output drive capability of the R/B# signal, the output voltage swing, and V_{CC} .

$$R_p(MIN, 3.3V \text{ part}) = \frac{V_{CC}(MAX) - V_{OL}(MAX)}{I_{OL} + \Sigma I_L} = \frac{3.2V}{8mA + \Sigma I_L}$$

Where ΣI_L is the sum of the input currents of all devices tied to the R/B# pin.

Figure 8: READY/BUSY# Open Drain

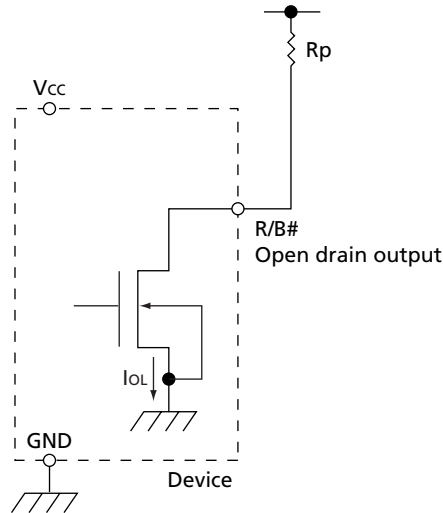
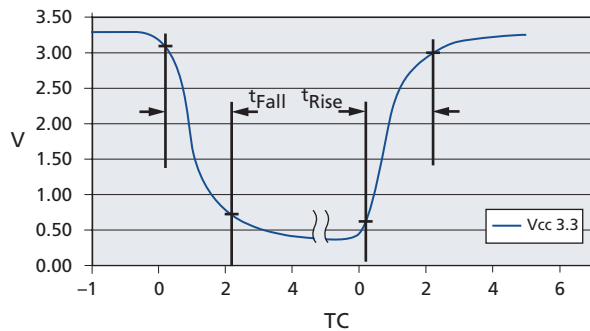

Figure 9: t_{Fall} and t_{Rise}



- Notes:
1. t_{Fall} and t_{Rise} calculated at 10 percent and 90 percent points.
 2. t_{Rise} is primarily dependent on external pull-up resistor and external capacitive loading.
 3. $t_{Fall} \approx 10ns$ at 3.3V.
 4. See TC values in Figure 11 on page 18 for approximate R_p value and TC.

Figure 10: IOL vs. Rp

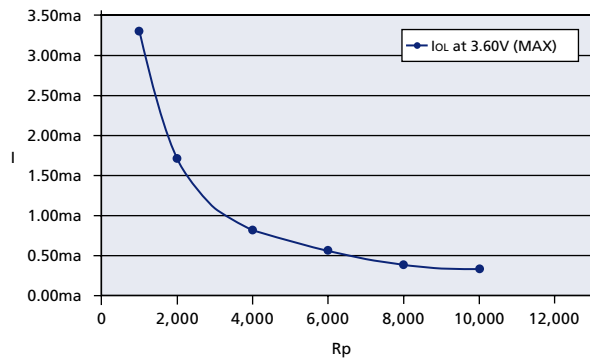

Figure 11: TC vs. Rp

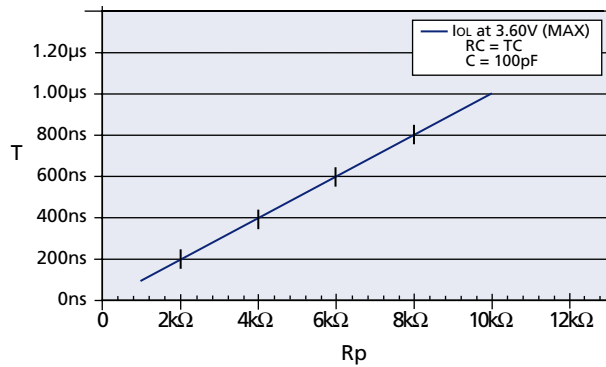

Table 5: Mode Selection

CLE	ALE	CE#	WE#	RE#	WP#	Mode	
H	L	L		H	X	Read mode	Command input
L	H	L		H	X		Address input
H	L	L		H	H	Write mode	Command input
L	H	L		H	H		Address input
L	L	L		H	H	Data input	
L	L	L	H		X	Sequential read and data output	
X	X	X	H	H	X	During read (busy)	
X	X	X	X	X	H	During program (busy)	
X	X	X	X	X	H	During erase (busy)	
X	X	X	X	X	L	Write protect	
X	X	H	X	X	0V/Vcc ¹	Standby	

- Notes:
1. WP# should be biased to CMOS HIGH or LOW for standby.
 2. Mode selection settings for this table: H = Logic level HIGH; L = Logic level LOW; X = VIH or VIL.

Command Definitions

Table 6: Command Set

Command	Command Cycle 1	Number of Address Cycles	Data Cycles Required ¹	Command Cycle 2	Valid During Busy	Notes
PAGE READ	00h	5	No	30h	No	
PAGE READ CACHE MODE	31h	–	No	–	No	2
PAGE READ CACHE MODE LAST	3Fh	–	No	–	No	2
READ for INTERNAL DATA MOVE	00h	5	No	35h	No	3
RANDOM DATA READ	05h	2	No	E0h	No	4
READ ID	90h	1	No	–	No	
READ STATUS	70h	–	No	–	Yes	
PROGRAM PAGE	80h	5	Yes	10h	No	5
PROGRAM PAGE CACHE MODE	80h	5	Yes	15h	No	5
PROGRAM for INTERNAL DATA MOVE	85h	5	Optional	10h	No	3
RANDOM DATA INPUT	85h	2	Yes	–	No	6
BLOCK ERASE	60h	3	No	D0h	No	5
RESET	FFh	–	No	–	Yes	
OTP DATA PROGRAM	A0h	5	Yes	10h	No	
OTP DATA PROTECT	A5h	5	No	10h	No	
OTP DATA READ	AFh	5	No	30h	No	

- Notes:
1. Indicates required data cycles between command cycle 1 and command cycle 2.
 2. Do not cross block address boundaries when using PAGE READ CACHE MODE operations.
 3. Do not cross plane address boundaries when using READ for INTERNAL DATA MOVE and PROGRAM for INTERNAL DATA MOVE. See Tables 3 and 4 on pages 13 and 14 for plane address boundary definitions.
 4. The RANDOM DATA READ command is limited to use within a single page.
 5. These commands are valid during busy when performing an interleaved die operation. See “Interleaved Die Operations” on page 47 for additional details.
 6. The RANDOM DATA INPUT command is limited to use within a single page.

Table 7: Two-Plane Command Set

Command	Command Cycle 1	Number of Address Cycles	Command Cycle 2	Number of Address Cycles	Command Cycle 3	Valid During Busy	Notes
TWO-PLANE PAGE READ	00h	5	00h	5	30h	No	
TWO-PLANE READ for INTERNAL DATA MOVE	00h	5	00h	5	35h	No	1
TWO-PLANE RANDOM DATA READ	06h	5	E0h	–	–	No	2
TWO-PLANE/MULTIPLE-DIE READ STATUS	78h	3	–	–	–	Yes	3
TWO-PLANE PROGRAM PAGE	80h	5	11h-80h	5	10h	No	4
TWO-PLANE PROGRAM PAGE CACHE MODE	80h	5	11h-80h	5	15h	No	4
TWO-PLANE PROGRAM for INTERNAL DATA MOVE	85h	5	11h-80h	5	10h	No	1
TWO-PLANE BLOCK ERASE	60h	3	60h	3	D0h	No	4

- Notes:
1. Do not cross plane address boundaries when using TWO-PLANE READ for INTERNAL DATA MOVE and TWO-PLANE PROGRAM for INTERNAL DATA MOVE. See Tables 3 and 4 on pages 13 and 14 for plane address boundary definitions.
 2. The TWO-PLANE RANDOM DATA READ command is limited to use with the TWO-PLANE PAGE READ command.
 3. The TWO-PLANE/MULTIPLE-DIE READ STATUS command can be used to check status with two-plane and multiple-die operations, excluding the TWO-PLANE PAGE READ (00h-00h-30h) command.
 4. These commands are valid during busy when performing interleaved die operations. See “Interleaved Die Operations” on page 47 for additional details.

READ Operations

PAGE READ 00h-30h

At power-on, the device defaults to READ mode. To enter READ mode while in operation, write the 00h command to the command register, then write 5 ADDRESS cycles, and conclude with the 30h command.

To determine the progress of the data transfer from the NAND Flash array to the data register (^tR), monitor the R/B# signal or, alternatively, issue a READ STATUS (70h) command. If the READ STATUS command is used to monitor the data transfer, the user must reissue the READ (00h) command to receive data output from the data register. See Figure 65 on page 72 and Figure 66 on page 73 for examples. After the READ command has been reissued, pulsing the RE# line will result in outputting data, starting from the initial column address.

A serial page read sequence outputs a complete page of data. After 30h is written, the page data is transferred to the data register, and R/B# goes LOW during the transfer. When the transfer to the data register is complete, R/B# returns HIGH. At this point, data can be read from the device. Starting from the initial column address and going to the end of the page, read the data by repeatedly pulsing RE# at the maximum ^tRC rate (see Figure 12).

Figure 12: PAGE READ Operation

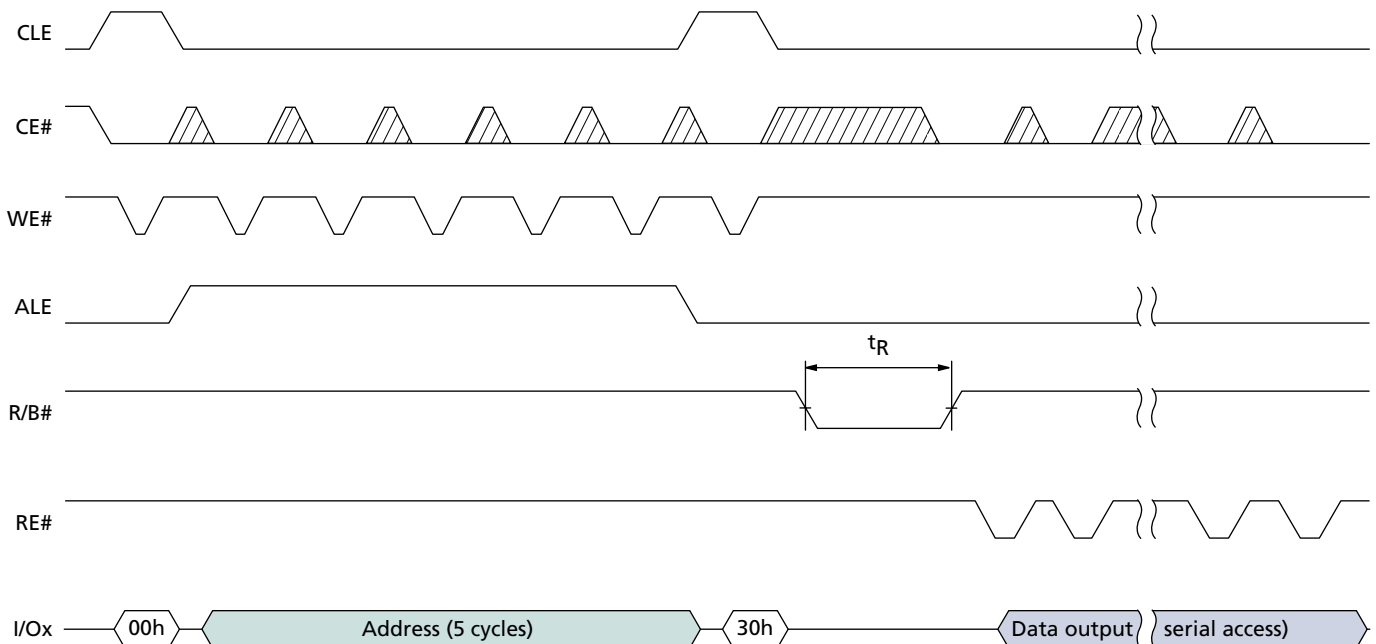

Don't Care

RANDOM DATA READ 05h-E0h

The RANDOM DATA READ command enables the user to specify a new column address so the data at single or multiple addresses can be read. The random read mode is enabled after a normal PAGE READ (00h-30h) sequence.

Random data can be output after the initial page read by writing an 05h-E0h command sequence along with the new column address (2 cycles).

The RANDOM DATA READ command can be issued without limit within the page.

Only data on the current page can be read. Pulsing the RE# pin outputs data sequentially (see Figure 13).

Figure 13: RANDOM DATA READ Operation

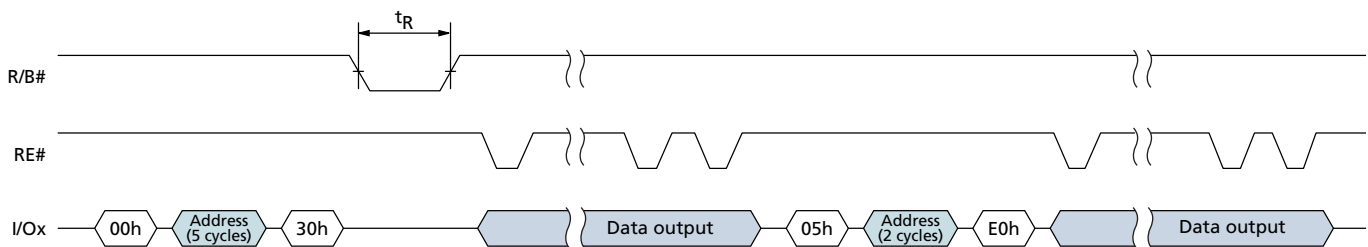

PAGE READ CACHE MODE START 31h; PAGE READ CACHE MODE START LAST 3Fh

Micron NAND Flash devices have a cache register that can be used to increase the READ operation speed when accessing sequential pages within a block.

First, issue a normal PAGE READ (00h-30h) command sequence. See Figure 14 on page 23 for operation details. The R/B# signal goes LOW for t_R during the time it takes to transfer the first page of data from the memory to the data register. After R/B# returns to HIGH, the PAGE READ CACHE MODE START (31h) command is latched into the command register. R/B# goes LOW for $t_{DCBSYR1}$ while data is being transferred from the data register to the cache register. After the data register contents are transferred to the cache register, another PAGE READ is automatically started as part of the 31h command. Data is transferred from the next sequential page of the memory array to the data register during the same time data is being read serially (pulsing RE#) from the cache register. If the total time to output data exceeds t_R , then the PAGE READ is hidden.

The second and subsequent pages of data are transferred to the cache register by issuing additional 31h commands. R/B# will stay LOW up to $t_{DCBSYR2}$. This time can vary, depending on whether the previous memory-to-data-register transfer was completed prior to issuing the next 31h command. See Table 18 on page 63 for timing parameters. If the data transfer from memory to the data register is not completed before the 31h command is issued, R/B# stays LOW until the transfer is complete.

It is not necessary to output a whole page of data before issuing another 31h command. R/B# will stay LOW until the previous PAGE READ is complete and the data has been transferred to the cache register.

To read out the last page of data, the PAGE READ CACHE MODE START LAST (3Fh) command is issued. This command transfers data from the data register to the cache register without issuing another PAGE READ (see Figure 14 on page 23).

Crossing block address boundaries when using the PAGE READ CACHE MODE operation is prohibited.

Figure 14: PAGE READ CACHE MODE Operation

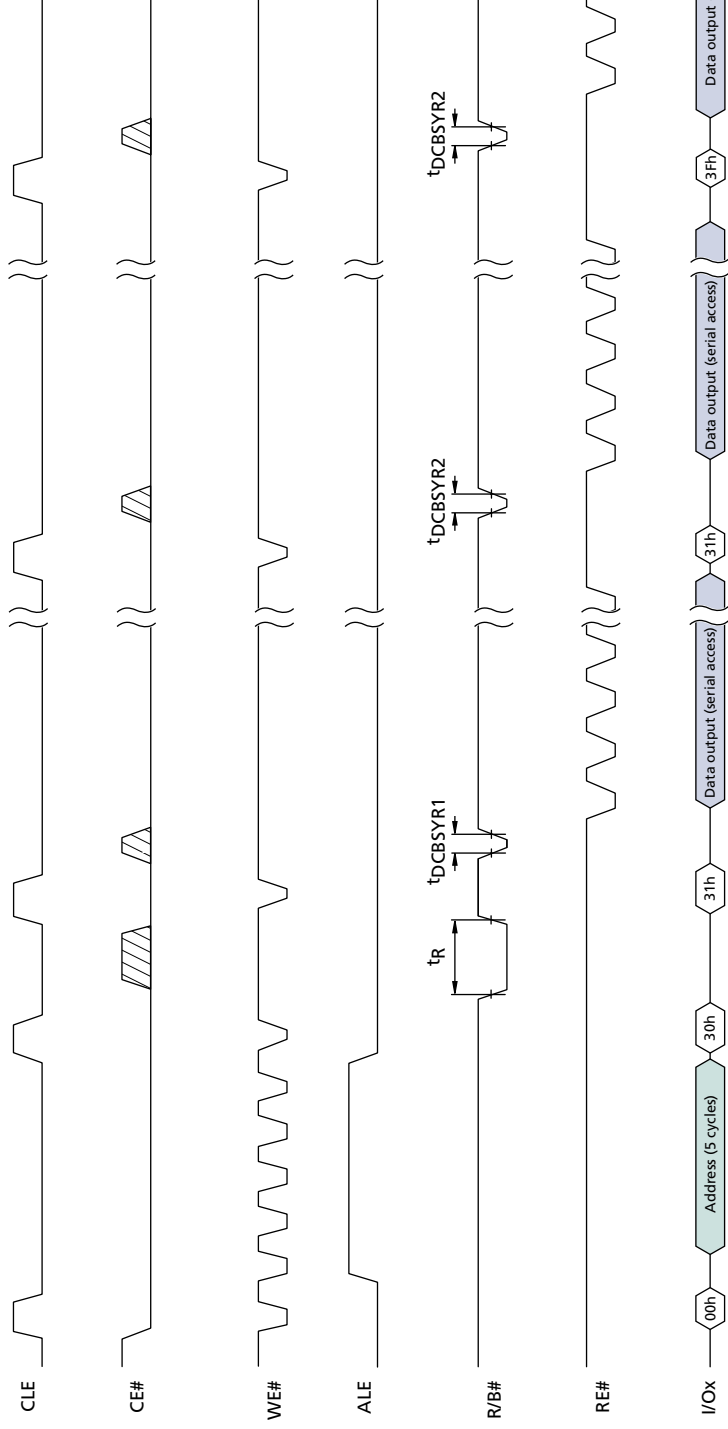

READ ID 90h

The READ ID command is used to read the 5 bytes of identifier code programmed into the NAND Flash devices. The READ ID command reads a 5-byte table that includes manufacturer ID, device configuration, and part-specific information (see Table 8 on page 25).

Writing 90h to the command register puts the device into the read ID mode. The command register stays in this mode until the next command cycle is issued (see Figure 15).

Figure 15: READ ID Operation

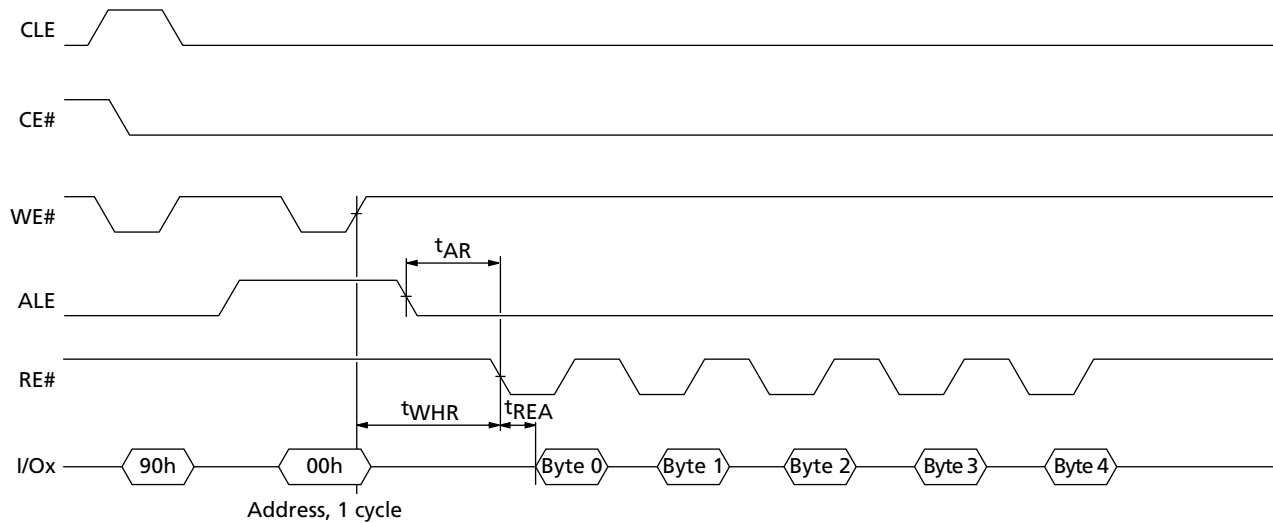

Notes: 1. See Table 8 on page 25 for byte definitions.



Table 8: Device ID and Configuration Codes

	Options	I/O7	I/O6	I/O5	I/O4	I/O3	I/O2	I/O1	I/O0	Value ¹	Notes
Byte 0	Manufacturer ID										
	Micron	0	0	1	0	1	1	0	0	2Ch	
Byte 1	Device ID										
MT29F4G08AAA	4Gb, x8, 3V	1	1	0	1	1	1	0	0	DCh	
MT29F8G08BAA	8Gb, x8, 3V	1	1	0	1	0	0	1	1	D3h	
MT29F8G08DAA	8Gb, x8, 3V	1	1	0	1	1	1	0	0	DCh	2
MT29F16G08FAA	16Gb, x8, 3V	1	1	0	1	0	0	1	1	D3h	3
Byte 2											
Number of die per CE	1							0	0	00b	
	2							0	1	01b	
Cell type	SLC					0	0			00b	
Number of simultaneously programmed pages	2			0	1					01b	
Interleaved operations between multiple die on the same CE#	Not supported		0							0b	
	Supported		1							1b	
Cache programming	Supported	1								1b	
Byte value	MT29F4G08AAA	1	0	0	1	0	0	0	0	90h	
	MT29F8G08BAA	1	1	0	1	0	0	0	1	D1h	3
	MT29F8G08DAA	1	0	0	1	0	0	0	0	90h	2
	MT29F16G08FAA	1	1	0	1	0	0	0	1	D1h	3
Byte 3											
Page size	2KB							0	1	01b	
Spare area size (bytes)	64B						1			1b	
Block size (w/o spare)	128KB			0	1					01b	
Organization	x8		0							0b	
Serial access (MIN)	25ns	1				0				1xxx0b	
Byte value	MT29FxG08xAA	1	0	0	1	0	1	0	1	95h	
Byte 4											
Reserved								0	0	00b	
Planes per CE#	2					0	1			01b	
	4					1	0			10b	
Plane size	2Gb		1	0	1					101b	
Reserved		0								0b	
Byte value	MT29F4G08AAA	0	1	0	1	0	1	0	0	54h	
	MT29F8G08BAA	0	1	0	1	1	0	0	0	58h	
	MT29F8G08DAA	0	1	0	1	0	1	0	0	54h	2
	MT29F16G08FAA	0	1	0	1	1	0	0	0	58h	3

- Notes:
1. b = binary; h = hex.
 2. The MT29F8G08DAA device ID code reflects the configuration of each 4Gb section.
 3. The MT29F16G08FAA device ID code reflects the configuration of each 8Gb section.

READ STATUS 70h

These NAND Flash devices have an 8-bit status register the software can read during device operation. Table 9 describes the status register.

After a READ STATUS command, all READ cycles will be from the status register until a new command is issued. Changes in the status register will be seen on I/O[7:0] as long as CE# and RE# are LOW; it is not necessary to start a new READ STATUS cycle to see these changes.

In devices that have more than one die sharing a common CE# pin, the READ STATUS (70h) command reports the status of the die that was last addressed. If interleaved operations are started on both die, then the TWO-PLANE/MULTIPLE-DIE READ STATUS (78h) command must be used to select the die that should report status. In this situation, using the READ STATUS (70h) command will result in bus contention, as both die will respond until the next operation is issued.

While monitoring the status register to determine when the ^tR (transfer from NAND Flash array to data register) is complete, the user must reissue the READ (00h) command to make the change from status to read mode. After the READ command has been reissued, pulsing the RE# line will result in outputting data, starting from the initial column address.

Table 9: Status Register Bit Definition

SR Bit	Program Page	Program Page Cache Mode	Page Read	Page Read Cache Mode	Block Erase	Definition
0 ¹	Pass/fail	Pass/fail (N)	–	–	Pass/fail	0 = Successful PROGRAM/ERASE 1 = Error in PROGRAM/ERASE
1	–	Pass/fail (N-1)	–	–	–	0 = Successful PROGRAM 1 = Error in PROGRAM
2	–	–	–	–	–	0
3	–	–	–	–	–	0
4	–	–	–	–	–	0
5	Ready/busy	Ready/busy ²	Ready/busy	Ready/busy ²	Ready/busy	0 = Busy 1 = Ready
6	Ready/busy	Ready/busy cache ³	Ready/busy	Ready/busy cache ³	Ready/busy	0 = Busy 1 = Ready
7	Write protect	Write protect	Write protect	Write protect	Write protect	0 = Protected 1 = Not protected

- Notes:
1. Status register bit 0 reports a “1” if a TWO-PLANE PROGRAM PAGE or TWO-PLANE BLOCK ERASE operation fails on one or both planes. Status register bit 1 reports a “1” if a TWO-PLANE PROGRAM PAGE CACHE MODE operation fails on one or both planes. Use TWO-PLANE/MULTIPLE-DIE READ STATUS (78h) to determine the plane to which the operation failed.
 2. Status register bit 5 is “0” during the actual programming operation. If cache mode is used, this bit will be “1” when all internal operations are complete.
 3. Status register bit 6 is “1” when the cache is ready to accept new data. R/B# follows bit 6. See Figure 19 on page 29 and Figure 73 on page 77.

Figure 16: Status Register Operation

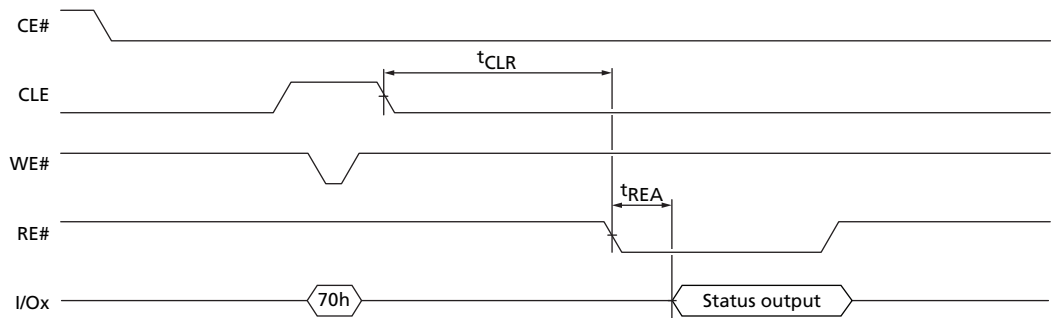

PROGRAM Operations

PROGRAM PAGE 80h-10h

Micron NAND Flash devices are inherently page-programmed devices. Pages must be programmed consecutively within a block, from the least significant page address to most significant page address (that is, 0, 1, 2, ..., 63). Random page address programming is prohibited.

Micron NAND Flash devices also support partial-page programming operations. This means that any single bit can only be programmed one time before an erase is required; however, the page can be partitioned such that a maximum of four programming operations are supported before an erase is required.

SERIAL DATA INPUT 80h

PROGRAM PAGE operations require loading the SERIAL DATA INPUT (80h) command into the command register, followed by 5 ADDRESS cycles, then the data. Serial data is loaded on consecutive WE# cycles starting at the given address. The PROGRAM (10h) command is written after the data input is complete. The control logic automatically executes the proper algorithm and controls all the necessary timing to program and verify the operation. Write verification only detects “1s” that are not successfully written to “0s.”

R/B# goes LOW for the duration of array programming time, t_{PROG} . The READ STATUS (70h) command and the RESET (FFh) command are the only commands valid during the programming operation. Bit 6 of the status register will reflect the state of R/B#. When the device reaches ready, read bit 0 of the status register to determine if the program operation passed or failed (see Figure 17 on page 28). The command register stays in read status register mode until another valid command is written to it.

RANDOM DATA INPUT 85h

After the initial data set is input, additional data can be written to a new column address with the RANDOM DATA INPUT (85h) command. The RANDOM DATA INPUT command can be used any number of times in the same page prior to issuing the PAGE WRITE (10h) command. See Figure 18 on page 28 for the proper command sequence.

Figure 17: PROGRAM and READ STATUS Operation

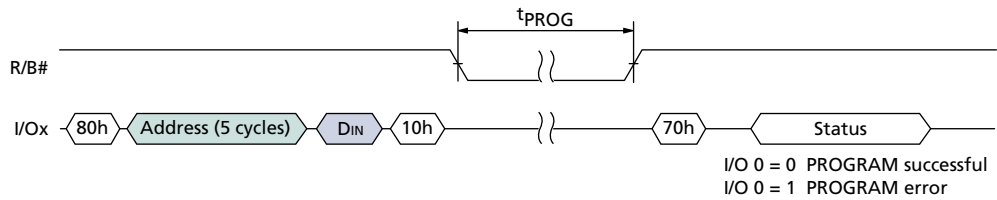
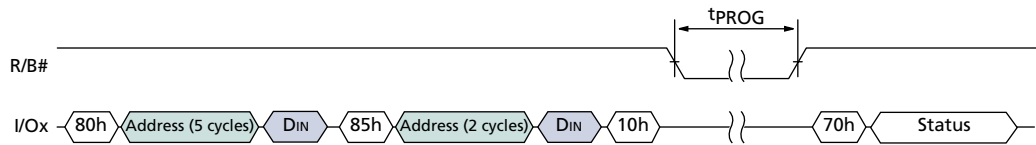

Figure 18: RANDOM DATA INPUT Operation



PROGRAM PAGE CACHE MODE 80h-15h

Cache programming is actually a buffered programming mode of the standard PROGRAM PAGE command. Programming is started by loading the SERIAL DATA INPUT (80h) command to the command register, followed by 5 cycles of address and a full or partial page of data. The data is initially copied into the cache register, and the CACHE PROGRAM (15h) command is then latched to the command register. Data is transferred from the cache register to the data register on the rising edge of WE#. R/B# goes LOW during this transfer time. After the data has been copied into the data register and R/B# returns to HIGH, memory array programming begins.

When R/B# returns to HIGH, new data can be written to the cache register by issuing another CACHE PROGRAM command sequence. The time that R/B# stays LOW will be controlled by the actual programming time. The first time through equals the time it takes to transfer the cache register contents to the data register. On the second and subsequent programming passes, transfer from the cache register to the data register is held off until current data register content has been programmed into the array.

The PROGRAM PAGE CACHE MODE command can cross block address boundaries; it must not cross die address boundaries. RANDOM DATA INPUT (85h) commands are permitted with PROGRAM PAGE CACHE MODE operations.

Bit 6 (Cache R/B#) of the status register can be read by issuing the READ STATUS (70h) command to determine when the cache register is ready to accept new data. The R/B# pin always follows bit 6.

Bit 5 (R/B#) of the status register can be polled to determine when the actual programming of the array is complete for the current programming cycle.

If just the R/B# pin is used to determine programming completion, the last page of the program sequence must use the PROGRAM PAGE (10h) command instead of the CACHE PROGRAM (15h) command. If the CACHE PROGRAM (15h) command is used every time, including the last page of the programming sequence, status register bit 5 must be used to determine when programming is complete (see Figure 19 on page 29).

Bit 0 of the status register returns the pass/fail for the previous page when bit 6 of the status register is a “1” (ready state). The pass/fail status of the current PROGRAM operation is returned with bit 0 of the status register when bit 5 of the status register is a “1” (ready state) as shown in Figure 19.

Figure 19: PROGRAM PAGE CACHE MODE Operation Example

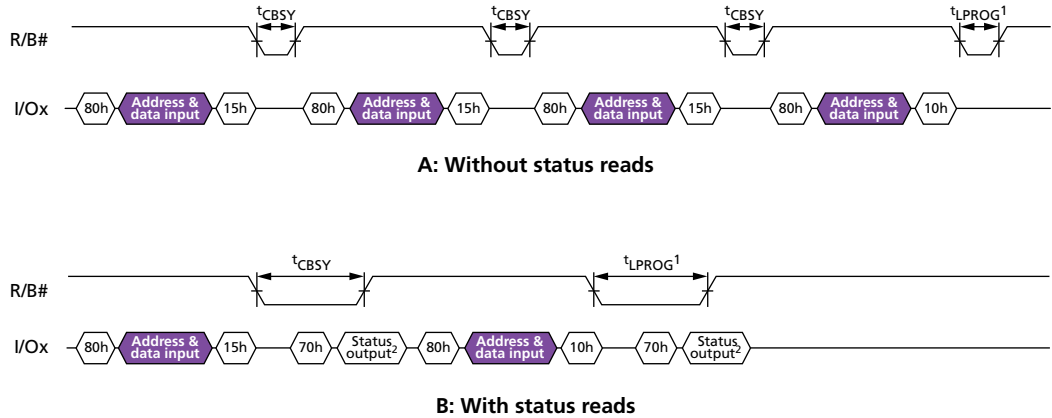

- Notes:
1. See Note 3, Table 19 on page 64.
 2. Check I/O[6:5] for internal ready/busy. Check I/O[1:0] for pass/fail status. RE# can stay LOW or pulse multiple times after a 70h command.

Internal Data Move

An internal data move requires two command sequences. Issue a READ for INTERNAL DATA MOVE (00h-35h) command first, then the PROGRAM for INTERNAL DATA MOVE (85h-10h) command. *Data moves are only supported within the plane from which data is read. Moving data from odd to even blocks, from even to odd blocks, and across die boundaries is prohibited.*

READ FOR INTERNAL DATA MOVE 00h-35h

The READ for INTERNAL DATA MOVE (00h-35h) command is used in conjunction with the PROGRAM for INTERNAL DATA MOVE (85h-10h) command. First, 00h is written to the command register, then the internal source address is written (5 cycles). After the address is input, the READ for INTERNAL DATA MOVE (35h) command writes to the command register. This transfers a page from memory into the cache register.

The written column addresses are ignored even though all 5 ADDRESS cycles are required.

The memory device is now ready to accept the PROGRAM for INTERNAL DATA MOVE command. Please refer to the description of this command in the following section.

PROGRAM for INTERNAL DATA MOVE 85h-10h

After the READ for INTERNAL DATA MOVE (00h-35h) command has been issued and R/B# goes HIGH, the PROGRAM for INTERNAL DATA MOVE (85h-10h) command can be written to the command register. This command transfers the data from the cache register to the data register and programming of the new destination page begins. The sequence: 85h, destination address (5 cycles), then 10h, is written to the device. After 10h is written, R/B# goes LOW while the control logic automatically programs the new page. The READ

STATUS command can be used instead of the R/B# line to determine when the write is complete. When status register bit 6 = 1, bit 0 of the status register indicates if the operation was successful.

The RANDOM DATA INPUT (85h) command can be used during the PROGRAM for INTERNAL DATA MOVE command sequence to modify one or more bytes of the original data. First, data is copied into the cache register using the 00h-35h command sequence, then the RANDOM DATA INPUT (85h) command is written along with the address of the data to be modified next. New data is input on the external data pins. This copies the new data into the cache register.

When 10h is written to the command register, the original data plus the modified data are transferred to the data register, and programming of the new page is started. The RANDOM DATA INPUT command can be issued as many times as necessary before starting the programming sequence with 10h (see Figures 20 and 21).

Because INTERNAL DATA MOVE operations do not use external memory, ECC cannot be used to check for errors before programming the data to a new page. This can lead to a data error if the source page contains a bit error due to charge loss or charge gain. In the case that multiple INTERNAL DATA MOVE operations are performed, these bit errors may accumulate without correction. For this reason, it is highly recommended that systems using INTERNAL DATA MOVE operations also use a robust ECC scheme that can correct two or more bits per sector.

Figure 20: INTERNAL DATA MOVE Operation

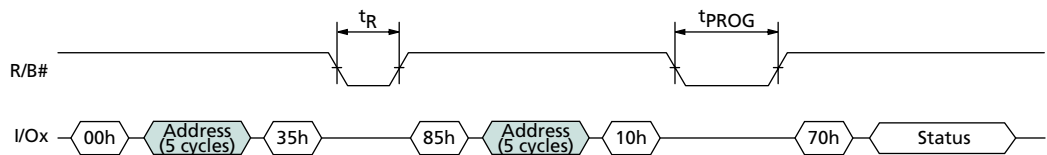

Notes: 1. INTERNAL DATA MOVE operations are only supported within the plane from which data is read.

Figure 21: INTERNAL DATA MOVE Operation with RANDOM DATA INPUT

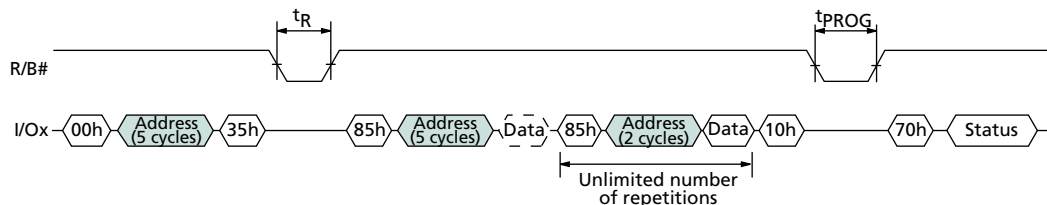

BLOCK ERASE Operation

BLOCK ERASE 60h-D0h

Erasing occurs at the block level. For example, the MT29F4G08AAA device has 4,096 erase blocks, organized into 64 pages per block, 2,112 bytes per page (2,048 + 64 bytes). Each block is 132K bytes (128K + 4K bytes). The BLOCK ERASE command operates on one block at a time (see Figure 22 on page 31).

Three cycles of addresses BA[18:6] and PA[5:0] are required. Although page addresses PA[5:0] are loaded, they are a “Don’t Care” and are ignored for BLOCK ERASE operations. See Table 3 on page 13 for addressing details.

The actual command sequence is a two-step process. The ERASE SETUP (60h) command is first written to the command register. Then 3 cycles of addresses are written to the device. Next, the ERASE CONFIRM (D0h) command is written to the command register. At the rising edge of WE#, R/B# goes LOW and the control logic automatically controls the timing and erase-verify operations. R/B# stays LOW for the entire t_{BERS} erase time.

The READ STATUS (70h) command can be used to check the status of the BLOCK ERASE operation. When bit 6 = 1, the ERASE operation is complete. Bit 0 indicates a pass/fail condition where 0 = pass (see Figure 22, and Table 9 on page 26).

Figure 22: BLOCK ERASE Operation

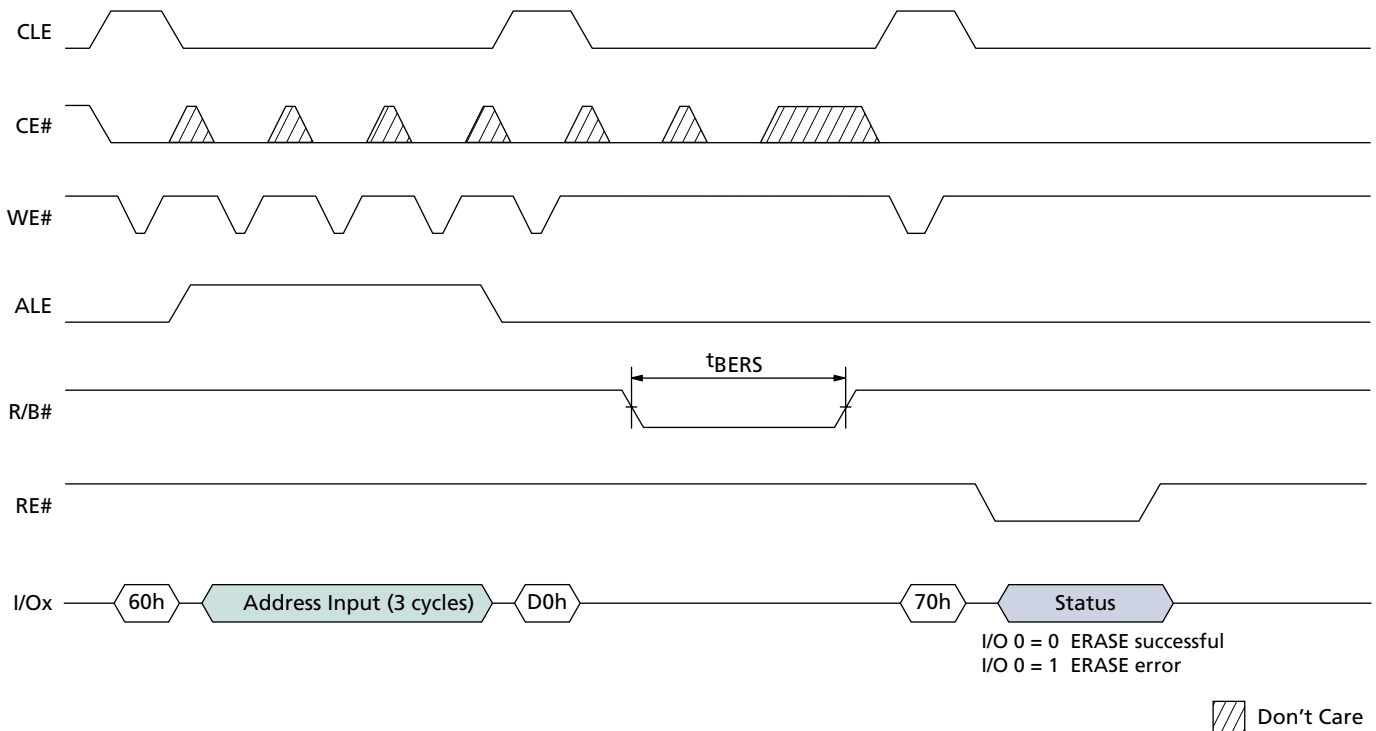

One-Time Programmable (OTP) Area

This Micron NAND Flash device offers a protected, one-time programmable NAND Flash memory area. Ten full pages (2,112 bytes per page) of OTP data is available on the device, and the entire range is guaranteed to be good. The OTP area is accessible only through the OTP commands. Customers can use the OTP area in any way they desire; typical uses include programming serial numbers or other data for permanent storage.

In Micron NAND Flash devices, the OTP area leaves the factory in a non-written state (all bits are "1s"). Programming or partial-page programming enables the user to program only "0" bits in the OTP area. The OTP area cannot be erased, even if it is not protected. Protecting the OTP area simply prevents further programming of the OTP area.

While the OTP area is referred to as "one-time programmable," Micron provides a unique way to program and verify data—before permanently protecting it and preventing future changes.

OTP programming and protection are accomplished in two discrete operations. First, using the OTP DATA PROGRAM (A0h-10h) command, an OTP page is programmed entirely in one operation or in up to four partial-page programming sequences. Programming can occur on other pages within the OTP area in a similar manner. Second, the OTP area is permanently protected from further programming using the OTP DATA PROTECT (A5h-10h) command. The pages within the OTP area can always be read using the OTP DATA READ (AFh-30h) command, whether or not it is protected.

To determine whether or not the device is busy during an OTP operation, either monitor R/B# or use the READ STATUS (70h) command. Use of the TWO-PLANE/MULTIPLE-DIE READ STATUS (78h) command is prohibited during and following OTP operations.

OTP DATA PROGRAM A0h-10h

The OTP DATA PROGRAM (A0h-10h) command is used to write data to the pages within the OTP area. An entire page can be programmed at one time, or a page can be partially programmed up to four times. There is no ERASE operation for the OTP pages.

The OTP DATA PROGRAM enables programming into an offset of an OTP page, using the two bytes of column address (CA[11:0]). The command is not compatible with the RANDOM DATA INPUT (85h) command. The OTP DATA PROGRAM command will not execute if the OTP area has been protected.

To use the OTP DATA PROGRAM command, issue the A0h command. Issue 5 ADDRESS cycles: the first 2 ADDRESS cycles are the column address, and for the remaining 3 cycles select a page in the range of 02h-00h-00h through 0Bh-00h-00h. Next, write from 1 to 2,112 bytes of data. After data input is complete, issue the 10h command. The internal control logic automatically executes the proper programming algorithm and controls the necessary timing for programming and verification. Program verification only detects “1s” that are not successfully written to “0s.”

R/B# goes LOW during the duration of the array programming time (^tPROG). The READ STATUS (70h) command is the only command valid during the OTP DATA PROGRAM operation. Bit 5 of the status register will reflect the state of R/B#. If bit 7 is “0,” then the OTP area has been protected; otherwise, it will be a “1.”

When the device is ready, read bit 0 of the status register to determine if the operation passed or failed (see Table 9 on page 26).

It is possible to program each OTP page a maximum of four times.

Figure 23: OTP DATA PROGRAM Operation

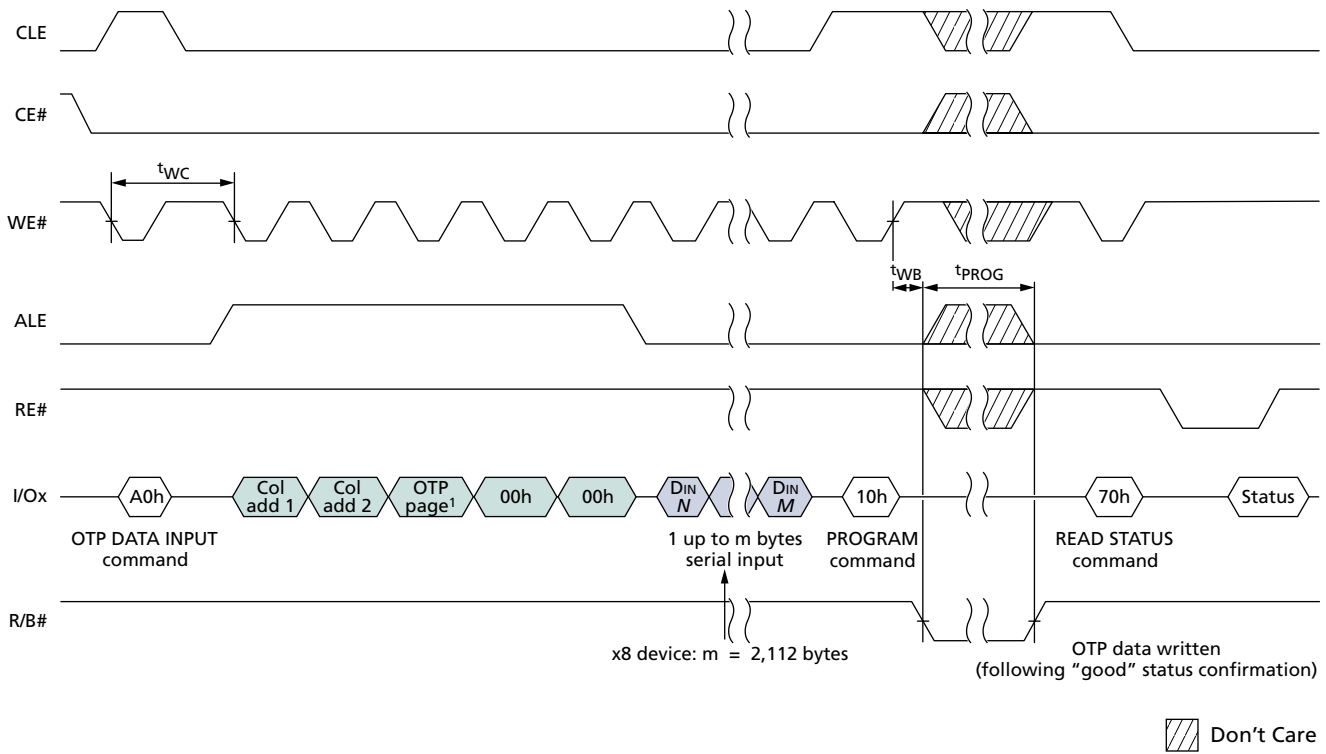

Notes: 1. The OTP page must be within the 02h–0Bh range.

OTP DATA PROTECT A5h-10h

The OTP DATA PROTECT (A5h-10h) command is used to protect all the data in the OTP area. After the data is protected it cannot be programmed further. When the OTP area is protected, the pages within the area are no longer programmable and cannot be unprotected.

To use the OTP DATA PROTECT command, issue the A5h command. Next, issue the following 5 ADDRESS cycles: 00h-00h-01h-00h-00h. Finally, issue the 10h command.

R/B# goes LOW while the OTP area is being protected. The protect command duration is similar to a normal page programming operation, t_{PROG} . The READ STATUS (70h) command is the only command valid during the OTP DATA PROTECT operation. Bit 5 of the status register will reflect the state of R/B#.

When the device is ready, read bit 0 of the status register to determine if the operation passed or failed (see Table 9 on page 26).

Figure 24: OTP DATA PROTECT Operation

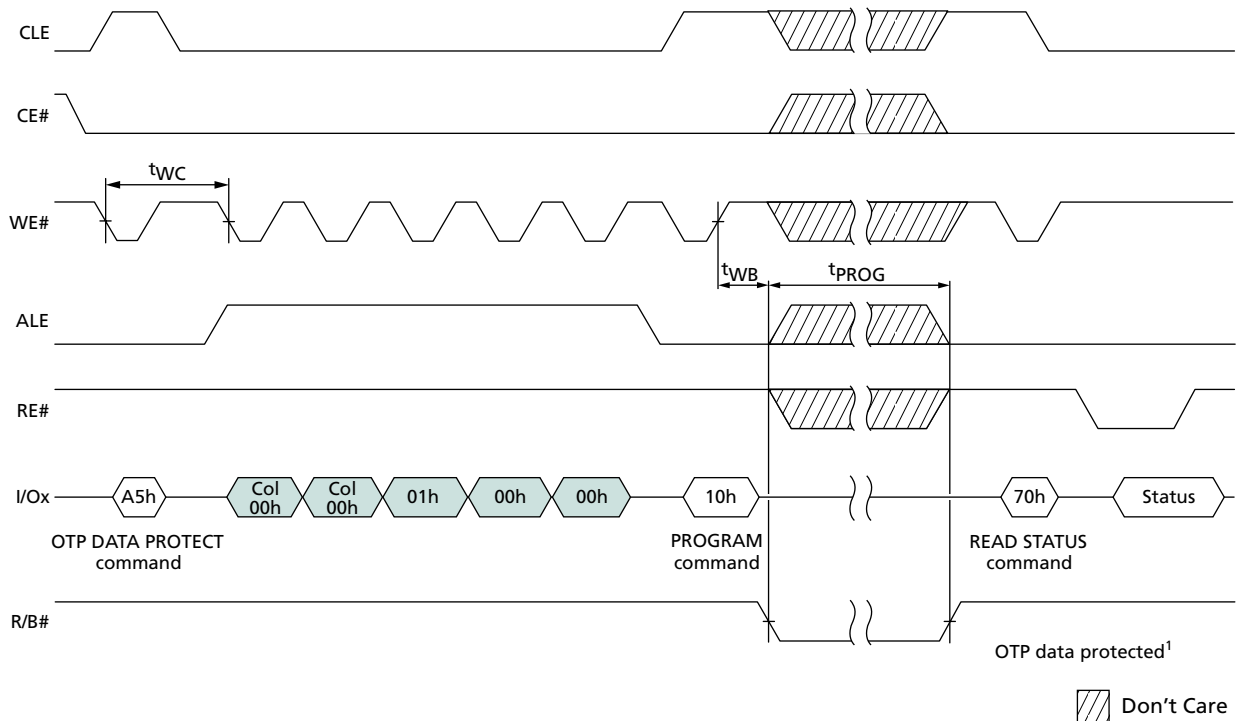

Notes: 1. OTP data is protected following "good" status confirmation.

OTP DATA READ AFh-30h

The OTP DATA READ (AFh-30h) command is used to read data from a page within the OTP area. An OTP page within the OTP area is available for reading data whether or not the area is protected.

To use the OTP DATA READ command, issue the AFh command. Next, issue 5 ADDRESS cycles: the first 2 ADDRESS cycles are the column address, and for the remaining 3 cycles select a page in the range of 02h-00h-00h through 0Bh-00h-00h. Finally, issue the 30h command.

R/B# goes LOW (t_R) while the data is moved from the OTP page to the data register. The READ STATUS (70h) command and the RESET (FFh) command are the only commands valid during the OTP DATA READ operation. Bit 5 of the status register will reflect the state of R/B#. For details, refer to Table 9 on page 26.

Normal READ operation timings apply to OTP read accesses (see Figure 25). Additional pages within the OTP area can be selected by repeating the OTP DATA READ command.

Figure 25: OTP DATA READ Operation

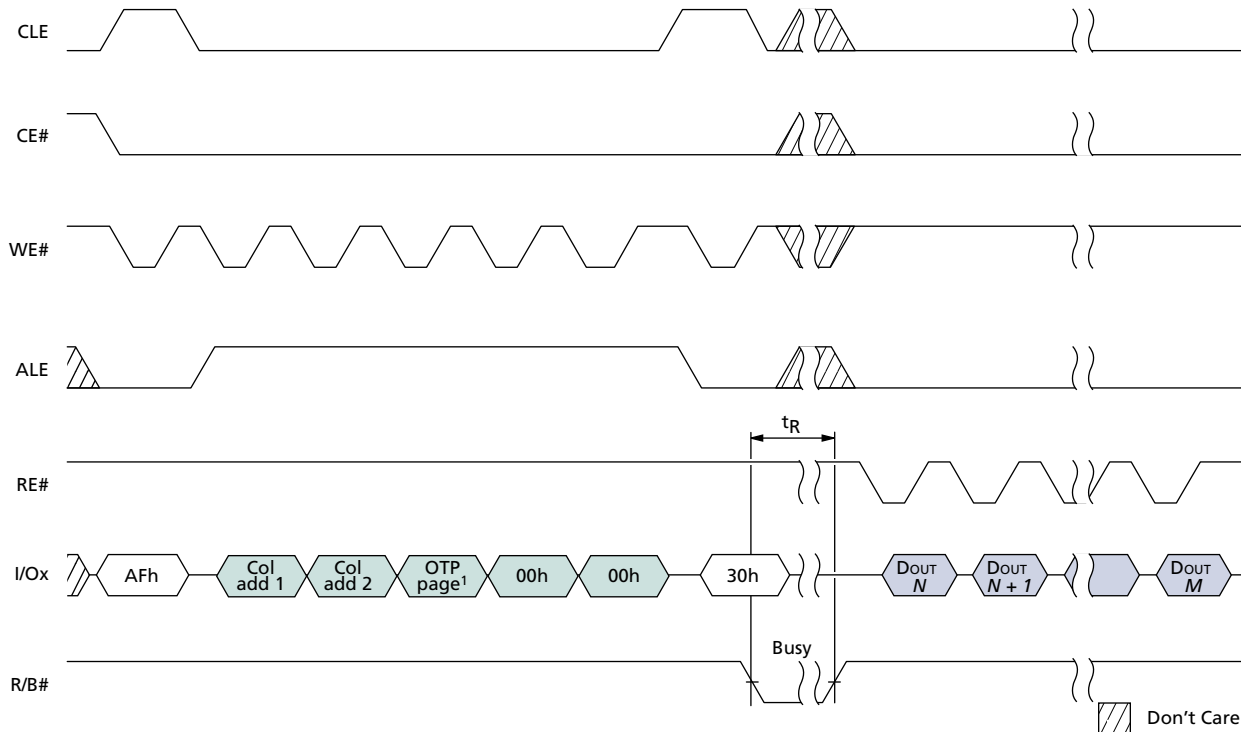

Notes: 1. The OTP page must be within the 02h–0Bh range.

TWO-PLANE Operations

This NAND Flash device is divided into two physical planes. Each plane contains a 2,112-byte data register, a 2,112-byte cache register, and a 2,048-block NAND Flash array. Two-plane commands make better use of the Flash arrays on these physical planes by performing PROGRAM, READ, or ERASE operations simultaneously, significantly improving system performance.

Two-Plane Addressing

Two-plane commands require two addresses, one address per plane. These two addresses are subject to the following requirements:

- The least significant block address bit, BA6, must be different for the two addresses.
- The most significant block address bit, BA18 for 16Gb devices and for 8Gb devices with 1 CE#, must be identical for each plane.
- The page address bits, PA[5:0], must be identical for both addresses.

TWO-PLANE PAGE READ 00h-00h-30h

The TWO-PLANE PAGE READ (00h-00h-30h) operation is similar to the PAGE READ (00h-30h) operation. It transfers two pages of data from the NAND Flash array to the data registers. Each page must be from a different plane on the same die.

To enter the TWO-PLANE PAGE READ mode, write the 00h command to the command register, then write 5 ADDRESS cycles for plane 0 (BA6 = 0). Next, write the 00h command to the command register, then write 5 ADDRESS cycles for plane 1 (BA6 = 1). Finally, issue the 30h command. The first-plane and second-plane addresses must meet the two-plane addressing requirements and, in addition, they must have identical column addresses.

After the 30h command is written, page data is transferred from both planes to their respective data registers in ^tR. During these transfers, R/B# goes LOW. When the transfers are complete, R/B# goes HIGH. To read out the data from the plane 0 data register, pulse RE# repeatedly. After the data cycle from the plane 0 address completes, issue a TWO-PLANE RANDOM DATA READ (06h-E0h) command to select the plane 1 address, then repeatedly pulse RE# to read out the data from the plane 1 data register.

Alternatively, the READ STATUS (70h) command can monitor data transfers. When the transfers are complete, status register bit 6 is set to “1.” To read data from the first of the two planes, the user must first issue the TWO-PLANE RANDOM DATA READ (06h-E0h) command (see “TWO-PLANE RANDOM DATA READ 06h-E0h”) and pulse RE# repeatedly. When the data cycle is complete, issue a TWO-PLANE RANDOM DATA READ (06h-E0h) command to select the other plane. To output the data beginning at the specified column address, pulse RE# repeatedly.

Use of the TWO-PLANE/MULTIPLE-DIE READ STATUS (78h) command is prohibited during and following a TWO-PLANE PAGE READ operation.

TWO-PLANE RANDOM DATA READ 06h-E0h

The TWO-PLANE RANDOM DATA READ (06h-E0h) command is similar to the RANDOM DATA READ (05h-E0h) command, except that it requires 5 ADDRESS cycles rather than 2. The command selects a die and plane, and a column address from which to read data after a TWO-PLANE PAGE READ (00h-00h-30h) command.

To issue a TWO-PLANE RANDOM DATA READ command, issue the 06h command, then 5 ADDRESS cycles, and follow with the E0h command. Pulse RE# repeatedly to read data from the new plane, beginning at the specified column address.

The primary purpose of the TWO-PLANE RANDOM DATA READ command is to select a new die and plane, and a column address within that die and plane. If a new die and plane do not need to be selected, then it is possible to use the RANDOM DATA READ (05h-E0h) command instead (see “RANDOM DATA READ 05h-E0h” on page 22).

Figure 27: TWO-PLANE PAGE READ Operation with RANDOM DATA READ

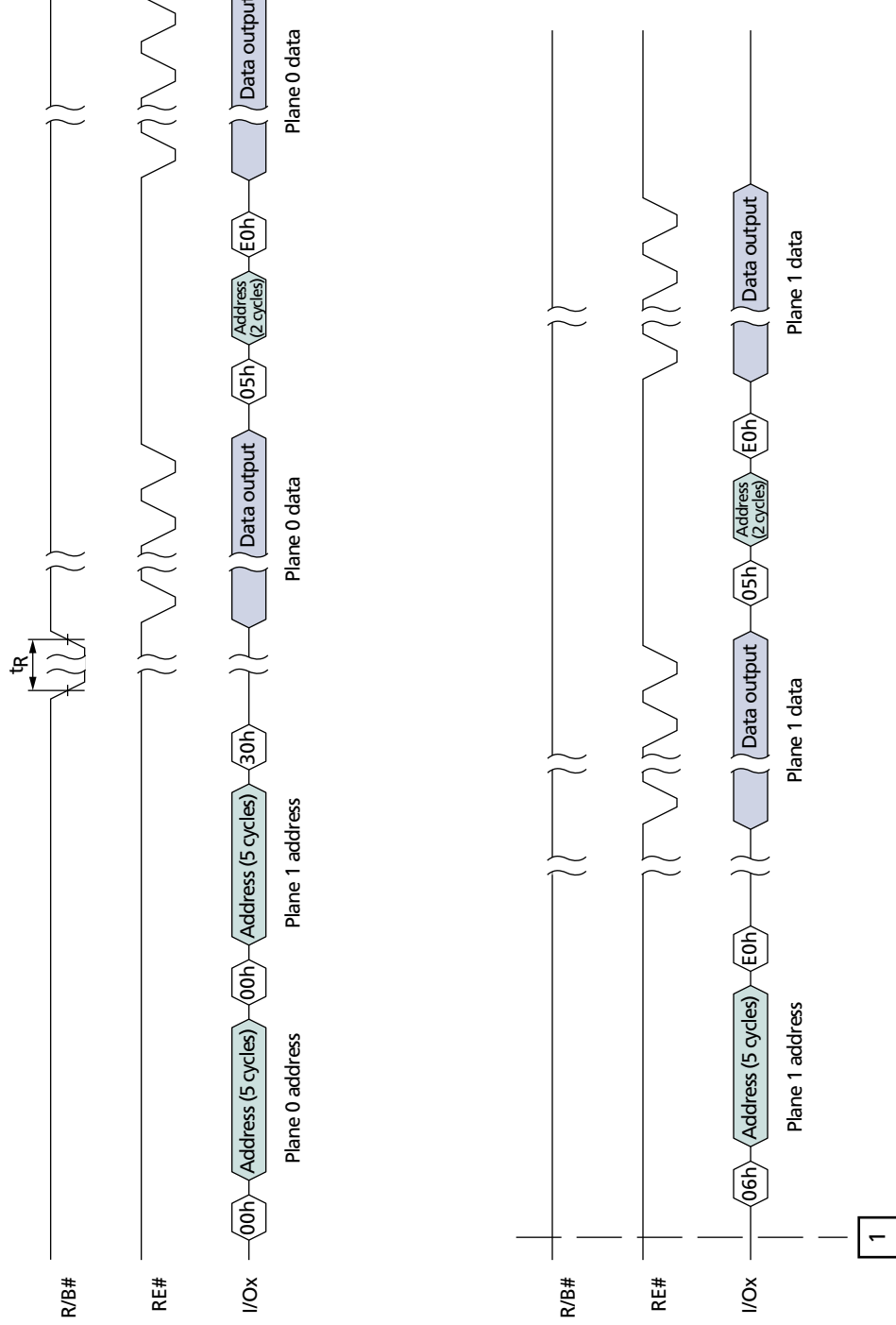

1

TWO-PLANE PROGRAM PAGE 80h-11h-80h-10h

The TWO-PLANE PROGRAM PAGE (80h-11h-80h-10h) operation is similar to the PROGRAM PAGE (80h-10h) operation. It programs two pages of data from the data registers to the Flash arrays. The pages must be programmed to different planes on the same die. Within a block, the pages must be programmed consecutively from the least significant to most significant page address. Random page programming within a block is prohibited. The first-plane address and the second-plane address must meet the two-plane addressing requirements (see “Two-Plane Addressing” on page 35).

To begin the TWO-PLANE PROGRAM PAGE operation, write the 80h command to the command register; write 5 ADDRESS cycles for the first plane; then write the data. Serial data is loaded on consecutive WE# cycles starting at the given address. Next, write the 11h command. The 11h command is a “dummy” command that informs the control logic that the first set of data for the first plane is complete. No programming of the NAND Flash array occurs. R/B# goes LOW for t_{DBSY} , then returns HIGH. The READ STATUS (70h) command also indicates that the device is ready when status register bit 6 is set to “1.” The only valid commands during t_{DBSY} are READ STATUS (70h) and RESET (FFh).

After t_{DBSY} , write the 80h (or 81h) command to the command register; write 5 ADDRESS cycles for the second plane; then write the data. The PROGRAM (10h) command is written after the second-plane data input is complete.

After the 10h command is written, the control logic automatically executes the proper algorithm and controls all the necessary timing to program and verify the operations to both planes. WRITE verification only detects “1s” that are not successfully written to “0s.”

R/B# goes LOW for the duration of the array programming time (t_{PROG}). When programming and verification are complete, R/B# returns HIGH. The READ STATUS (70h) command also indicates that the device is ready when status register bit 6 is set to “1.” The only valid commands during t_{PROG} are READ STATUS (70h), TWO-PLANE/MULTIPLE-DIE READ STATUS (78h), and RESET (FFh).

When the device is ready, if the READ STATUS (70h) command indicates an error in the operation (status register bit 0 = 1), use the TWO-PLANE/MULTIPLE-DIE READ STATUS (78h) command twice—once for each plane—to determine which plane operation failed.

During serial data input for either plane, the RANDOM DATA INPUT (85h) command can be used any number of times to change the column address within that plane. For details on this command, see “RANDOM DATA INPUT 85h” on page 27. Figure 28 shows TWO-PLANE PROGRAM PAGE operation.

Figure 28: TWO-PLANE PROGRAM PAGE Operation

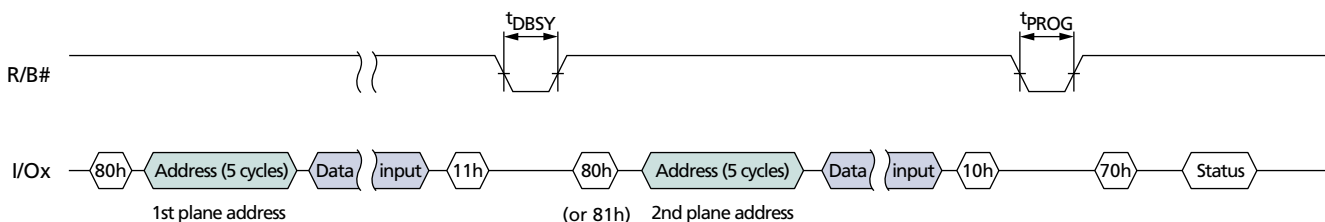
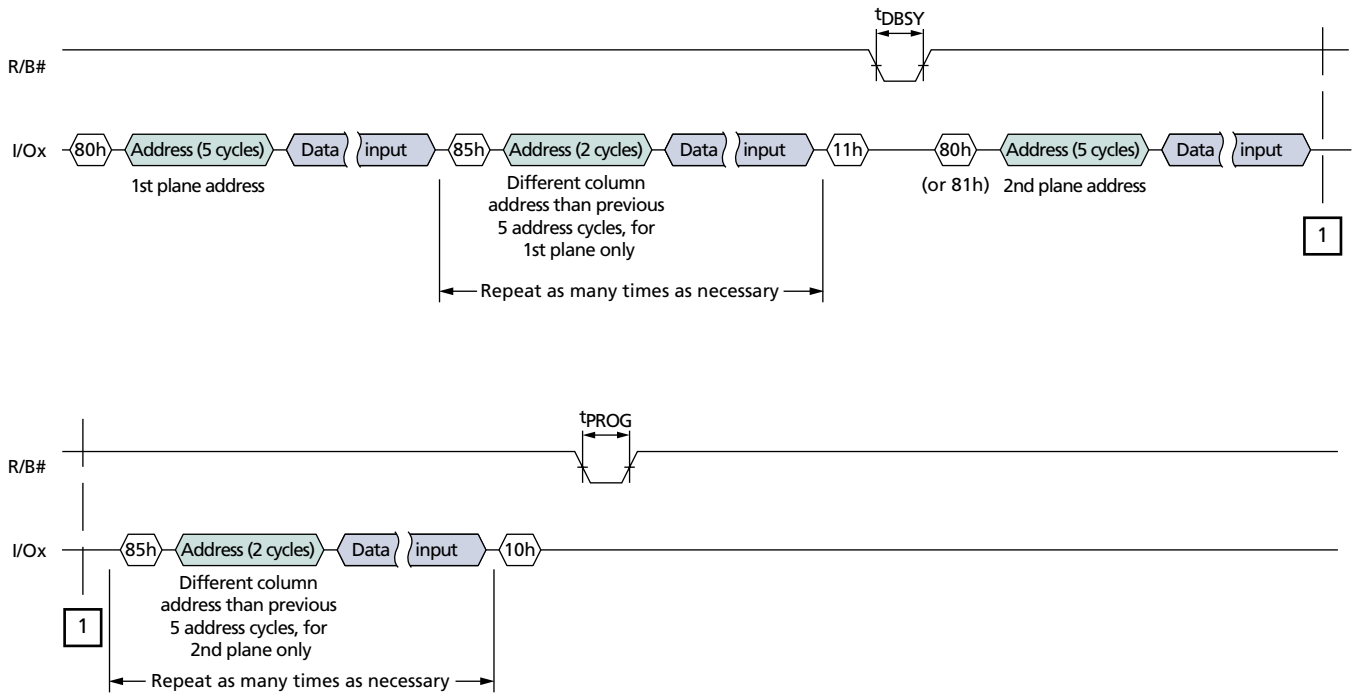

Figure 29: TWO-PLANE PROGRAM PAGE Operation with RANDOM DATA INPUT



TWO-PLANE PROGRAM PAGE CACHE MODE 80h-11h-80h-15h

The TWO-PLANE PROGRAM PAGE CACHE MODE (80h-11h-80h-15h) operation is similar to the PROGRAM PAGE CACHE MODE (80h-15h) operation. It programs two pages of data from the data registers to the NAND Flash arrays. The pages must be programmed to different planes on the same die. Within a block, the pages must be programmed consecutively from the least significant to the most significant page address. Random page programming within a block is prohibited. The first-plane and second-plane addresses must meet the two-plane addressing requirements (see “Two-Plane Addressing” on page 35).

To enter the two-plane program page cache mode, write the 80h command to the command register, write 5 ADDRESS cycles for the first plane, then write the data. Serial data is loaded on consecutive WE# cycles starting at the given address. Next, write the 11h command. The 11h command is a “dummy” command that informs the control logic that the first set of data for the first plane is complete. No programming of the NAND Flash array occurs. R/B# goes LOW for t_{DBSY} , then returns HIGH. The READ STATUS (70h) command also indicates that the device is ready when status register bit 6 is set to “1.” The only valid commands during t_{DBSY} are READ STATUS (70h) and RESET (FFh).

After t_{DBSY} , write the 80h (or 81h) command to the command register, write 5 ADDRESS cycles for the second plane, then write the data. The CACHE WRITE (15h) command is written after the second-plane data input is complete. Data is transferred from the cache registers to the data registers on the rising edge of WE#. R/B# goes LOW during this transfer time. After the data has been copied into the data registers and R/B# returns HIGH, memory array programming to both planes begins.

When R/B# returns HIGH, new data can be written to the cache registers by issuing another TWO-PLANE PROGRAM PAGE CACHE MODE (80h-11h-80h-15h) command sequence. The time that R/B# stays LOW (t_{CBSY}) is determined by the actual programming time of the previous operation. For the first cache operation, the duration of t_{CBSY} is the time it takes for the data to be copied from the cache registers to the data registers. On the second and subsequent TWO-PLANE PROGRAM PAGE CACHE MODE operations, transfer from the cache registers to the data registers is delayed until the current data register contents have been programmed into the arrays.

If the R/B# pin is used to determine programming completion, the last operation of the program sequence must use the TWO-PLANE PROGRAM PAGE (80h-11h-80h-10h) command instead of the TWO-PLANE PROGRAM PAGE CACHE MODE (80h-11h-80h-15h) command. If the TWO-PLANE PROGRAM PAGE CACHE MODE (80h-11h-80h-15h) command is used for the last operation, then use READ STATUS (70h) to monitor operation progress; status register bit 5 indicates when programming is complete. See Table 9 on page 26 for details of the status register.

To determine when the current TWO-PLANE PROGRAM PAGE CACHE MODE (80h-11h-80h-10h) operation has completed, issue the READ STATUS (70h) command and check status register bits 5 and 6. When the device is ready, use status register bit 0 to determine if the current operation passed and status register bit 1 to determine if the previous operation passed. If either bit 0 or bit 1 = 1, indicating a failed operation, then use the TWO-PLANE/MULTIPLE-DIE READ STATUS (78h) command twice—once for each plane—to determine which current or previous plane operation failed. For more information on status register bit definitions, see Table 9 on page 26.

During the serial data input for either plane, the RANDOM DATA INPUT (85h) command can be used any number of times to change the column address within that plane. For details on this command, see “RANDOM DATA INPUT 85h” on page 27. See Figure 29 on page 40 for an example.

Figure 30: TWO-PLANE PROGRAM PAGE CACHE MODE Operation

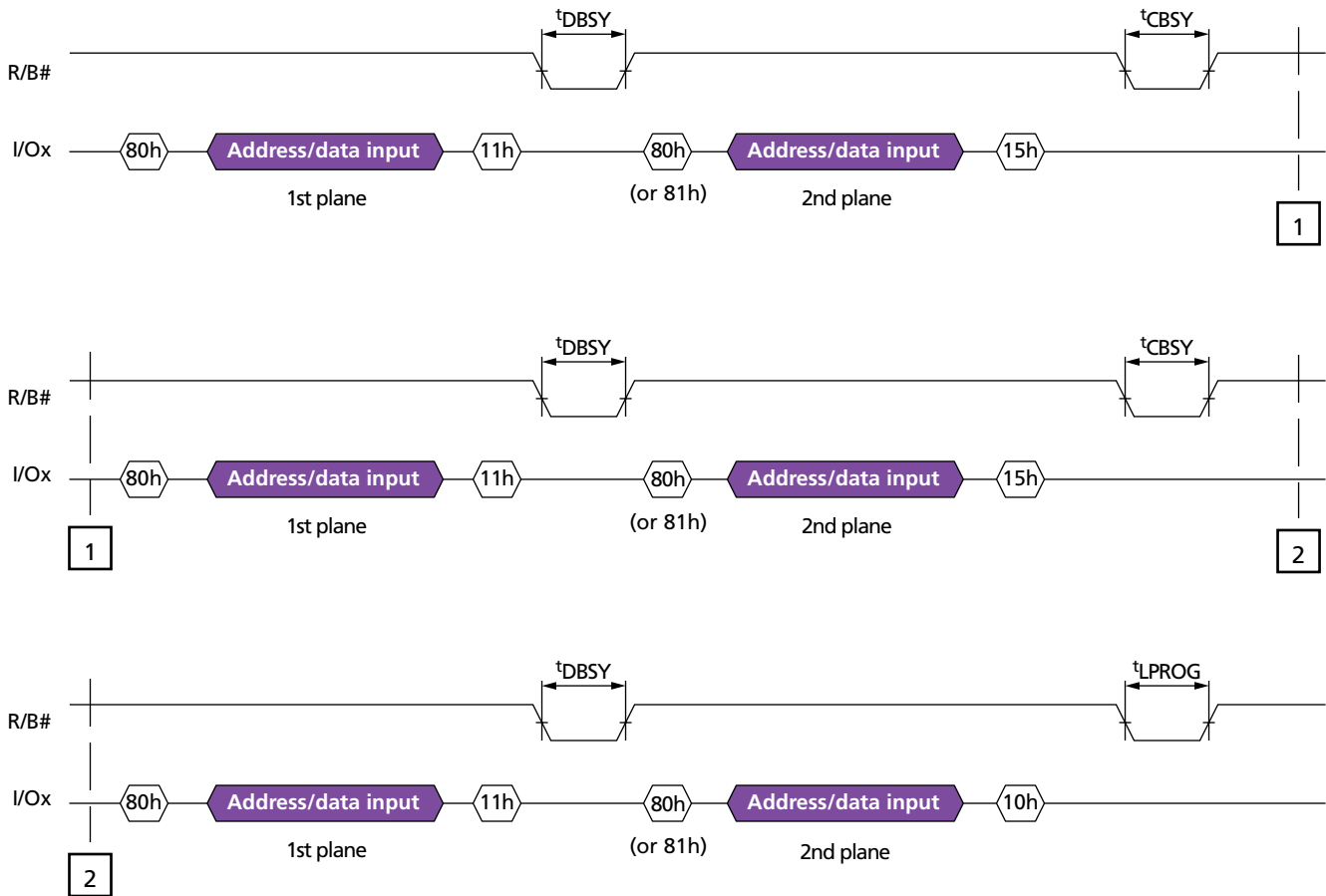

TWO-PLANE INTERNAL DATA MOVE 00h-00h-35h/85h-11h-80h-10h

A TWO-PLANE INTERNAL DATA MOVE operation is similar to an INTERNAL DATA MOVE operation, and requires two sequences. Issue a TWO-PLANE READ for INTERNAL DATA MOVE (00h-00h-35h) command first, then the TWO-PLANE PROGRAM for INTERNAL DATA MOVE (85h-11h-80h-10h) command. Data moves are only supported within the planes from which data is read. The first-plane and second-plane addresses must meet the two-plane addressing requirements for both the TWO-PLANE READ for INTERNAL DATA MOVE (00h-00h-35h) and TWO-PLANE PROGRAM for INTERNAL DATA MOVE (85h-11h-80h-10h) commands (see “Two-Plane Addressing” on page 35).

TWO-PLANE READ for INTERNAL DATA MOVE 00h-00h-35h

The TWO-PLANE READ for INTERNAL DATA MOVE (00h-00h-35h) command is used in conjunction with the TWO-PLANE PROGRAM for INTERNAL DATA MOVE (85h-11h-80h-10h) command. First, write 00h to the command register, then write the first-plane internal source address (5 cycles). Again, write 00h to the command register, followed by the second-plane internal source address (5 cycles). Finally, write 35h to the command register. After the 35h command, R/B# goes LOW for t_R while two pages are read into their respective cache registers.

The memory device is now ready to accept the TWO-PLANE PROGRAM for INTERNAL DATA MOVE (85h-11h-80h-10h) command.

TWO-PLANE PROGRAM for INTERNAL DATA MOVE 85h-11h-80h-10h

After the TWO-PLANE READ for INTERNAL DATA MOVE (00h-00h-35h) command has been issued and R/B# goes HIGH (or the status register bit 6 is “1”), the TWO-PLANE PROGRAM for INTERNAL DATA MOVE (85h-11h-80h-10h) command is used. Pages must be read from and programmed to the same plane.

First, write 85h to the command register, then write the first-plane destination address (5 cycles), then write 11h to the command register. The 11h command is a “dummy” command that informs the control logic that the first set of data for the first plane is complete. No programming of the NAND Flash array occurs. R/B# goes LOW for t_{DBSY} , then returns HIGH. The READ STATUS (70h) command also indicates that the device is ready when status register bit 6 is set to “1.” The only valid commands during t_{DBSY} are READ STATUS (70h) and RESET (FFh).

After t_{DBSY} , write the 80h (or 81h) command to the command register, then write the second-plane destination address (5 cycles), then write 10h to the command register. Data is transferred from the cache registers to the data registers on the rising edge of WE#, and programming begins on both planes.

R/B# goes LOW for the duration of array programming time, t_{PROG} . When programming and verification are complete, R/B# returns HIGH. The READ STATUS (70h) command also indicates that the device is ready when status register bit 6 is set to “1.” The only valid commands during t_{PROG} are READ STATUS (70h), TWO-PLANE/MULTIPLE-DIE READ STATUS (78h), and RESET (FFh).

If the READ STATUS (70h) command indicates an error in the operation (status register bit 0 = 1), use the TWO-PLANE/MULTIPLE-DIE READ STATUS (78h) command twice—once for each plane—to determine which plane operation failed.

During the serial data input for either plane, the RANDOM DATA INPUT (85h) command can be used any number of times to change the column address within that plane. For details on this command, see “RANDOM DATA INPUT 85h” on page 27. See Figure 32 on page 44 for an example.

Figure 31: TWO-PLANE INTERNAL DATA MOVE Operation

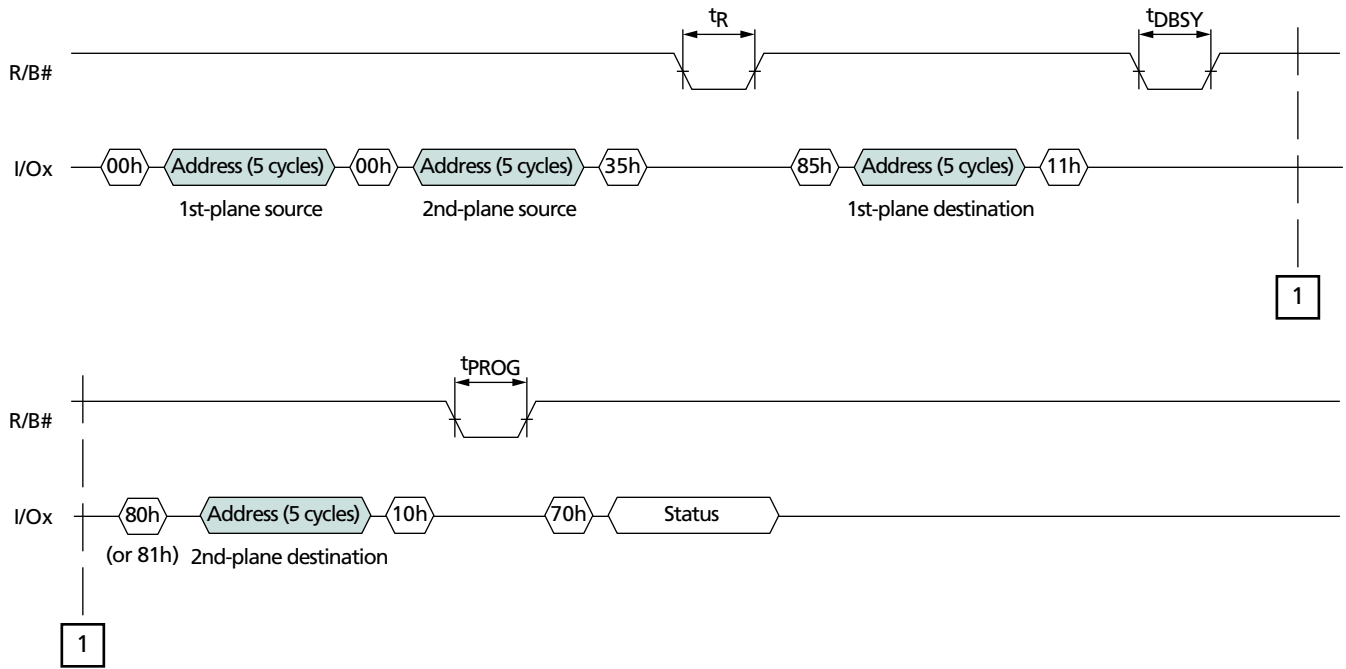
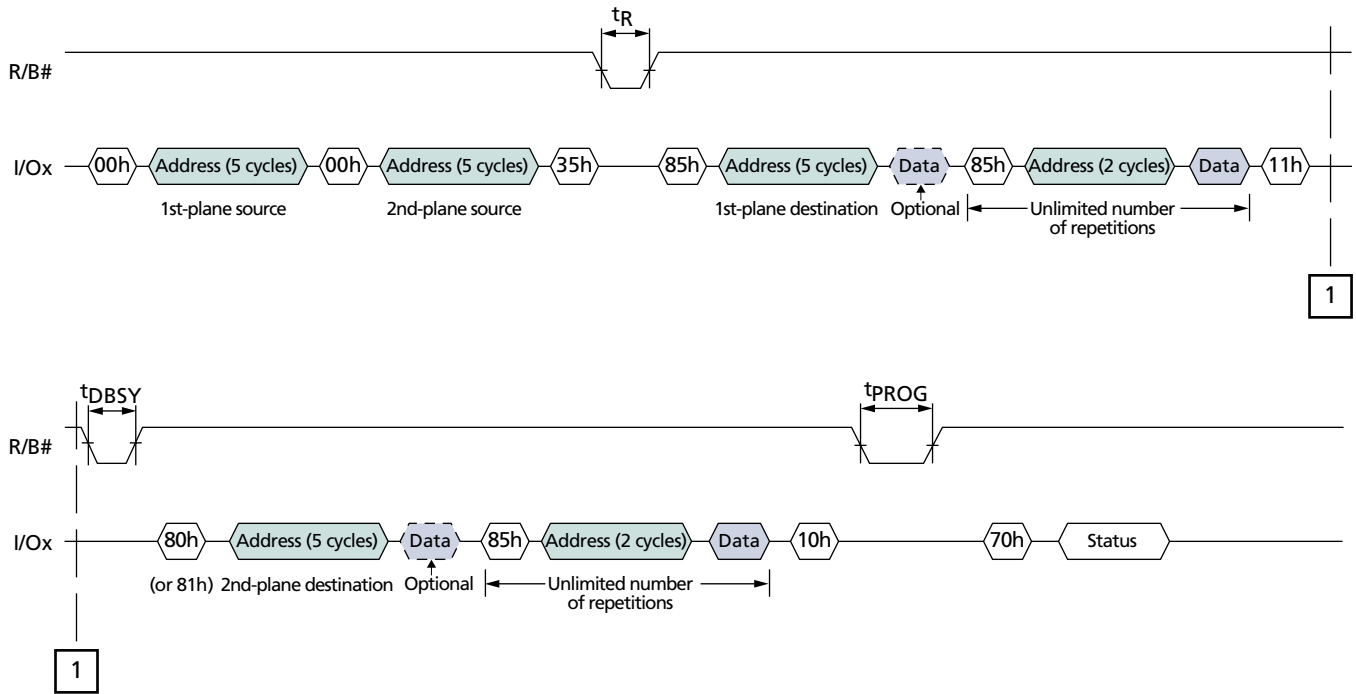

Figure 32: TWO-PLANE INTERNAL DATA MOVE Operation with RANDOM DATA INPUT



TWO-PLANE BLOCK ERASE 60h-60h-D0h

The TWO-PLANE BLOCK ERASE (60h-60h-D0h) operation is similar to the BLOCK ERASE (60h-D0h) operation. It erases two blocks instead of one. The blocks to be erased must be on different planes on the same die. The first-plane and second-plane addresses must meet the two-plane addressing requirements (see “Two-Plane Addressing” on page 35). Additionally, the page addresses, PA[5:0], for both planes must be LOW.

Begin a TWO-PLANE BLOCK ERASE operation by writing 60h to the command register, followed by 3 ADDRESS cycles of the first-plane block address. Then write 60h again to the command register, followed by 3 ADDRESS cycles of the second-plane block address. Finally, issue the D0h command.

R/B# goes LOW for the duration of block erase time, t_{BERS} . When block erasure is complete, R/B# returns HIGH. The READ STATUS (70h) command also indicates that the device is ready when status register bit 6 is set to “1.” The only valid commands during t_{BERS} are READ STATUS (70h), TWO-PLANE/MULTIPLE-DIE READ STATUS (78h), and RESET (FFh).

If the READ STATUS (70h) command indicates an error in the operation (status register bit 0 = 1), then use the TWO-PLANE/MULTIPLE-DIE READ STATUS (78h) command twice—once for each plane—to determine which plane operation failed.

Figure 33: TWO-PLANE BLOCK ERASE Operation

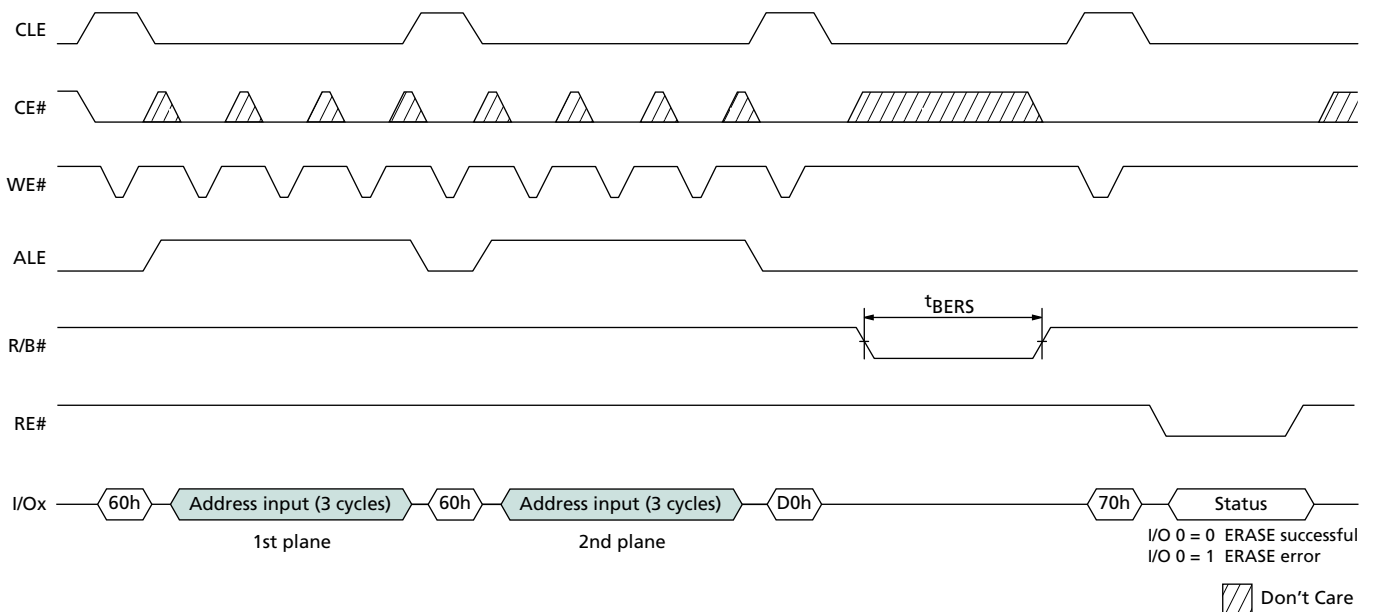

TWO-PLANE/MULTIPLE-DIE READ STATUS 78h

In Micron NAND Flash devices that have two planes, and possibly more than one die in a package that share the same CE# pin, it is possible to independently poll the status register of a particular plane and die using the TWO-PLANE/MULTIPLE-DIE READ STATUS (78h) command. This command can be used to check the status register during and after two-plane operations (with the exception of TWO-PLANE PAGE READ), and to check the status of interleaved die operations.

After the 78h command is issued, the device requires 3 ADDRESS cycles containing the block and page addresses, BA[18:6] and PA[5:0]. The most significant block address bit in the third ADDRESS cycle, BA18, selects the proper die, and the least significant block address bit in the first ADDRESS cycle, BA6, selects the proper plane within that die.

After the 78h command and the 3 ADDRESS cycles, the status register is output on I/O[7:0] when RE# is LOW. Changes in the status register will be seen on I/O[7:0] as long as CE# and RE# are LOW; it is not necessary to issue a new TWO-PLANE/MULTIPLE-DIE READ STATUS command to see these changes. The status register bit definitions are identical to those reported by the READ STATUS (70h) command (see Table 9 on page 26).

In devices that have more than one die sharing a common CE# pin, when one die is not busy (status register bit 5 is “1”), it is possible to initiate a new operation to that die even if the other die is busy (see “Interleaved Die Operations” on page 47).

If both die are busy during or following an interleaved die operation, the READ STATUS (70h) command must not be used to check status, as both die will respond, causing bus contention on I/O[7:0]. The TWO-PLANE/MULTIPLE-DIE READ STATUS (78h) command is required to check status during and after interleaved die operations.

Use of the TWO-PLANE/MULTIPLE-DIE READ STATUS (78h) command is prohibited during and following power-on RESET and OTP commands.

Figure 34: TWO-PLANE/MULTIPLE-DIE READ STATUS Cycle

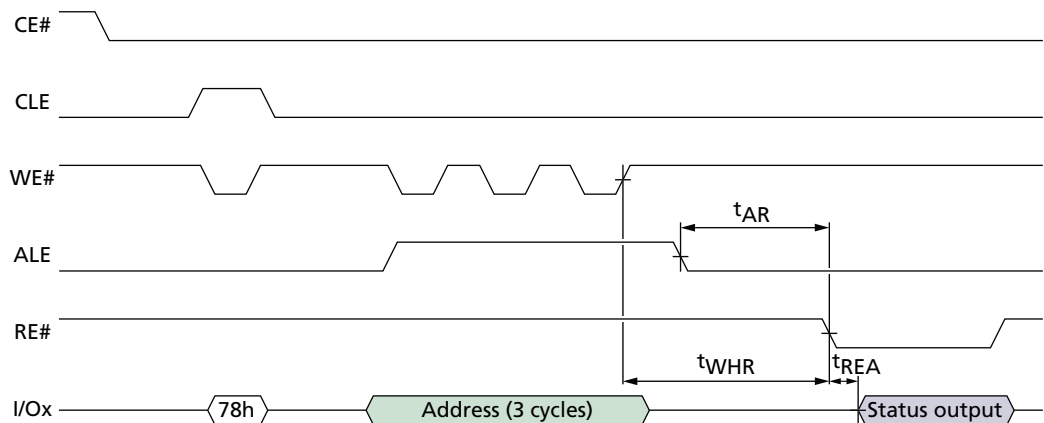

Interleaved Die Operations

In devices that have more than one die sharing a common CE# pin, it is possible to significantly improve performance by interleaving operations between the die. When both die are idle (R/B# is HIGH or status register bit 5 is “1”), issue a command to the first die (BA18 = 0). Then, while the first die is busy (R/B# is LOW), issue a command to the other die (BA18 = 1).

There are two ways to verify operation completion in each die: using the R/B# signal, or monitoring the status register. R/B# remains LOW while either die is busy. When R/B# goes HIGH, then both die are idle and the operations are complete. Alternatively, the TWO-PLANE/MULTIPLE-DIE READ STATUS (78h) command can report the status of each die individually. If a die is performing a cache operation, like PROGRAM PAGE CACHE MODE (80h-15h) or TWO-PLANE PROGRAM PAGE CACHE MODE (80h-11h-80h-15h), then the die is able to accept the data for another cache operation when status register bit 6 is “1.” All operations, including cache operations, are complete on a die when status register bit 5 is “1.”

During and following interleaved die operations, the READ STATUS (70h) command is prohibited. Instead, use the TWO-PLANE/MULTIPLE-DIE READ STATUS (78h) command. This command selects which die will report status. Interleaved two-plane commands must also meet the requirements in “Two-Plane Addressing” on page 35.

PROGRAM PAGE, PROGRAM PAGE CACHE MODE, TWO-PLANE PROGRAM PAGE, TWO-PLANE PROGRAM PAGE CACHE MODE, BLOCK ERASE, and TWO-PLANE BLOCK ERASE can be used as interleaved operations on separate die that share a common CE#.

Interleaved PROGRAM PAGE Operations

Figures 35 and 36 show how to perform two types of interleaved PROGRAM PAGE operations. In Figure 35, the R/B# signal is monitored for operation completion. In Figure 36 on page 48, the status register is monitored for operation completion with the TWO-PLANE/MULTIPLE-DIE READ STATUS (78h) command.

RANDOM DATA INPUT (85h) is permitted during interleaved PROGRAM PAGE operations.

Figure 35: Interleaved PROGRAM PAGE Operation with R/B# Monitoring

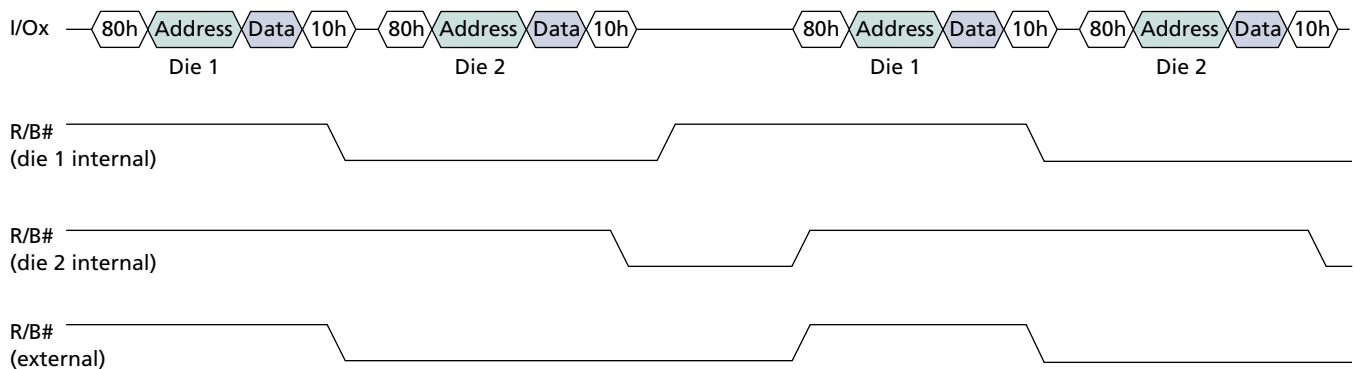
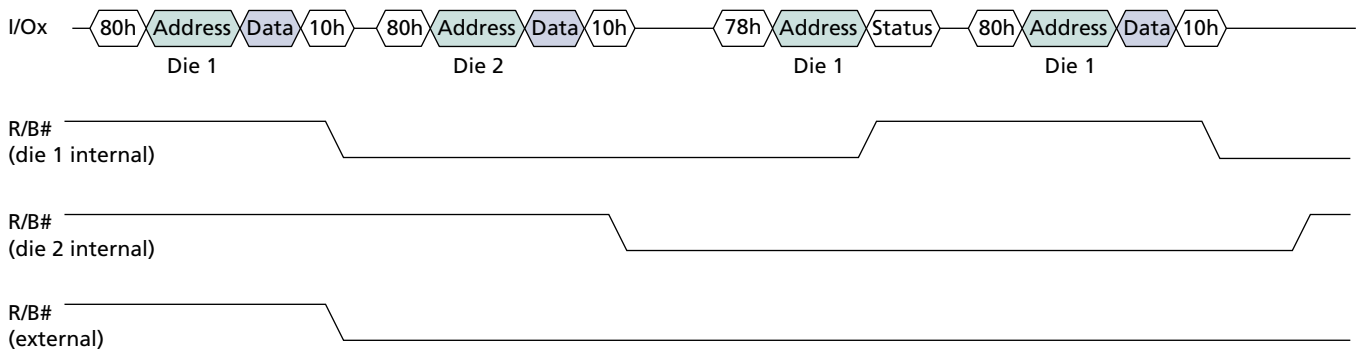

Figure 36: Interleaved PROGRAM PAGE Operation with Status Register Monitoring



Interleaved PROGRAM PAGE CACHE MODE Operations

Figures 37 and 38 show how to perform two types of interleaved PROGRAM PAGE CACHE MODE operations. In Figure 37, the R/B# signal is monitored. In Figure 38 on page 49, the status register is monitored with the TWO-PLANE/MULTIPLE-DIE READ STATUS (78h) command.

RANDOM DATA INPUT (85h) is permitted during interleaved PROGRAM PAGE CACHE MODE operations.

Figure 37: Interleaved PROGRAM PAGE CACHE MODE Operation with R/B# Monitoring

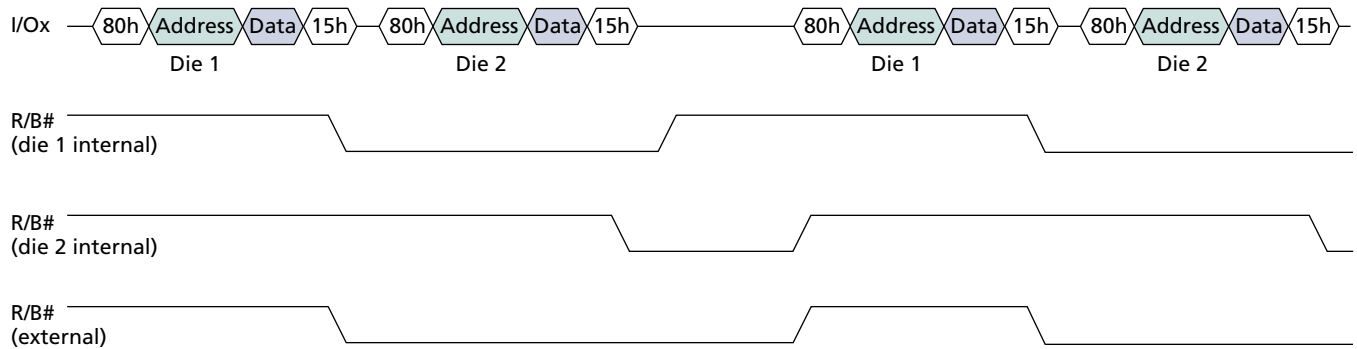
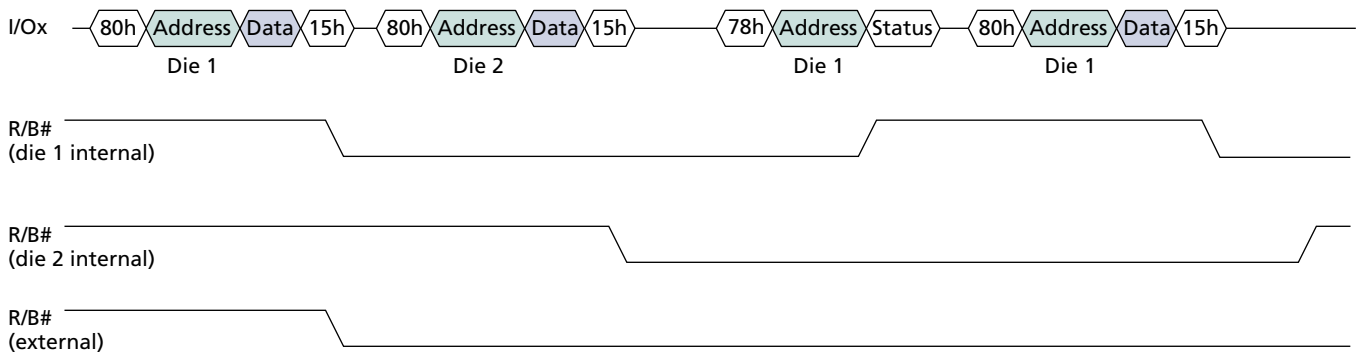

Figure 38: Interleaved PROGRAM PAGE CACHE MODE Operation with Status Register Monitoring



Interleaved TWO-PLANE PROGRAM PAGE Operations

Figure 39 on page 50 and Figure 40 on page 51 show how to perform two types of interleaved TWO-PLANE PROGRAM PAGE operations. In Figure 39, the R/B# signal is monitored for operation completion. In Figure 40, the TWO-PLANE/MULTIPLE-DIE READ STATUS (78h) command is used to monitor the status register for operation completion.

The interleaved TWO-PLANE PROGRAM PAGE operation must meet two-plane addressing requirements. See “Two-Plane Addressing” on page 35 for details.

RANDOM DATA INPUT (85h) is permitted during interleaved TWO-PLANE PROGRAM PAGE operations.

Figure 39: Interleaved TWO-PLANE PROGRAM PAGE Operation with R/B# Monitoring

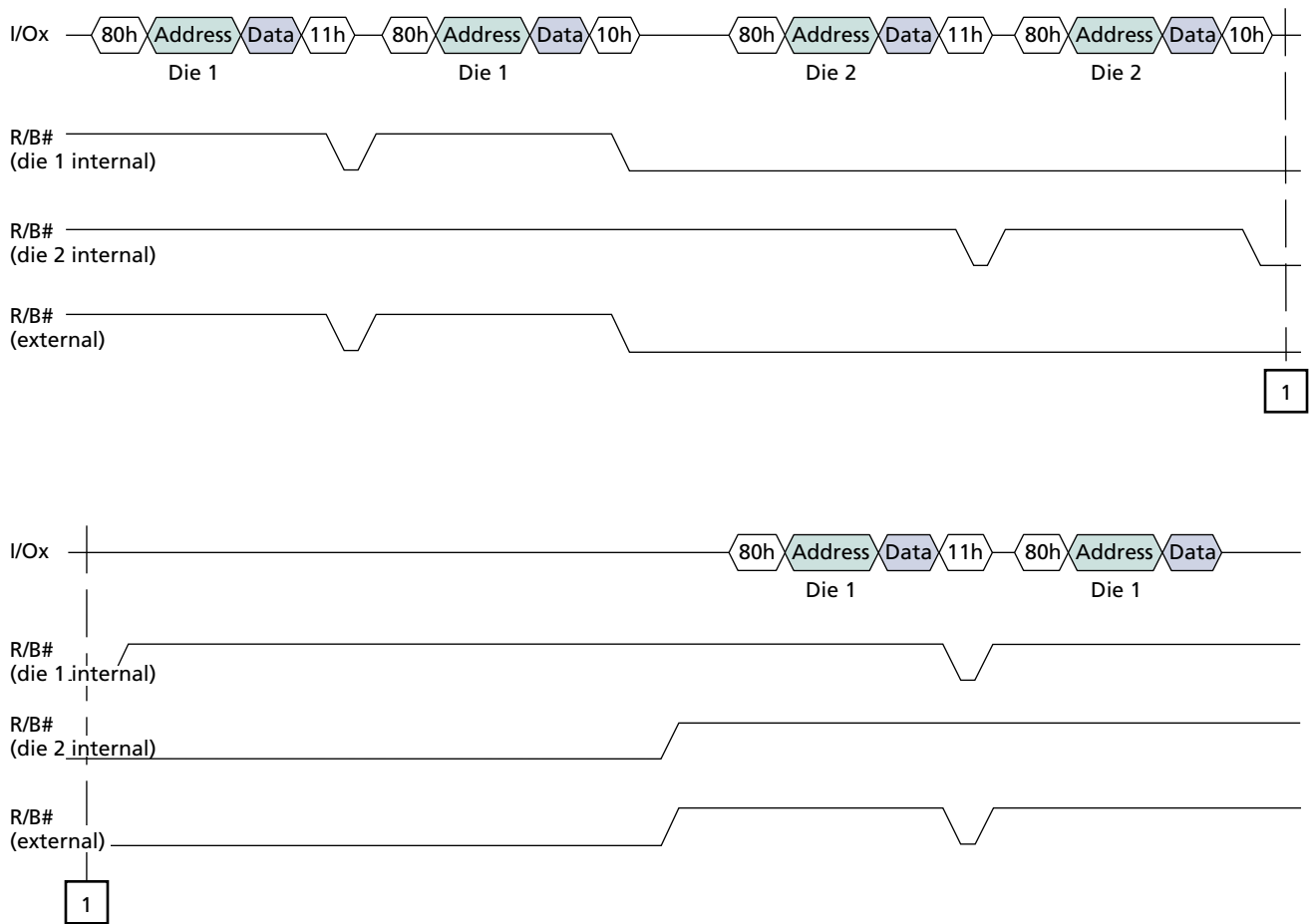

Notes: 1. Two-plane addressing requirements apply.

Interleaved TWO-PLANE PROGRAM PAGE CACHE MODE Operations

Figures 41 and 42 show how to perform two types of interleaved TWO-PLANE PROGRAM PAGE CACHE MODE operations. In Figure 41, the R/B# signal is monitored. In Figure 42 on page 53, the status register is monitored with the TWO-PLANE/MULTIPLE-DIE READ STATUS (78h) command.

The interleaved TWO-PLANE PROGRAM PAGE CACHE MODE operation must meet two-plane addressing requirements. See “Two-Plane Addressing” on page 35 for details.

RANDOM DATA INPUT (85h) is permitted during interleaved TWO-PLANE PROGRAM PAGE CACHE MODE operations.

Figure 41: Interleaved TWO-PLANE PROGRAM PAGE CACHE MODE Operation with R/B# Monitoring

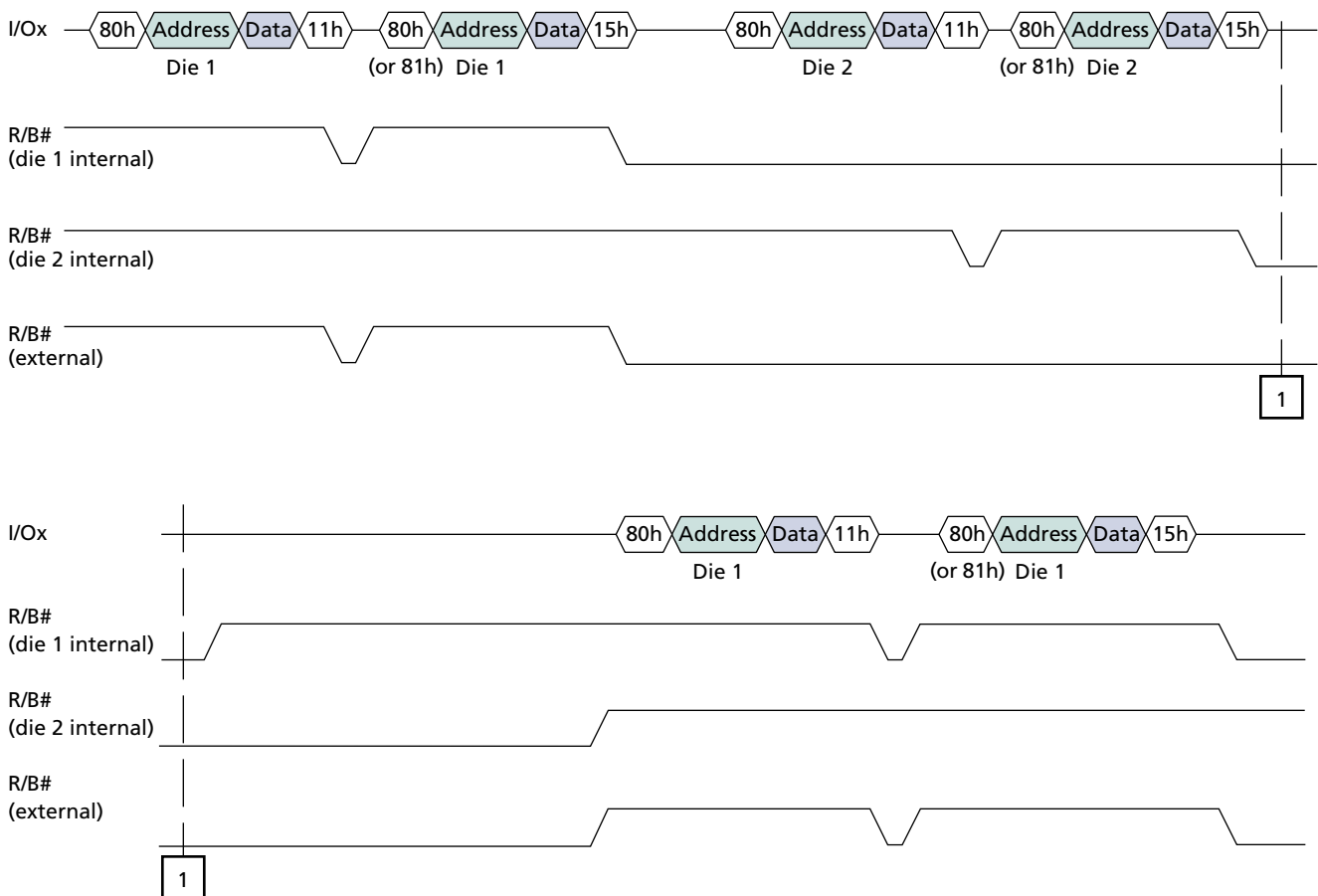
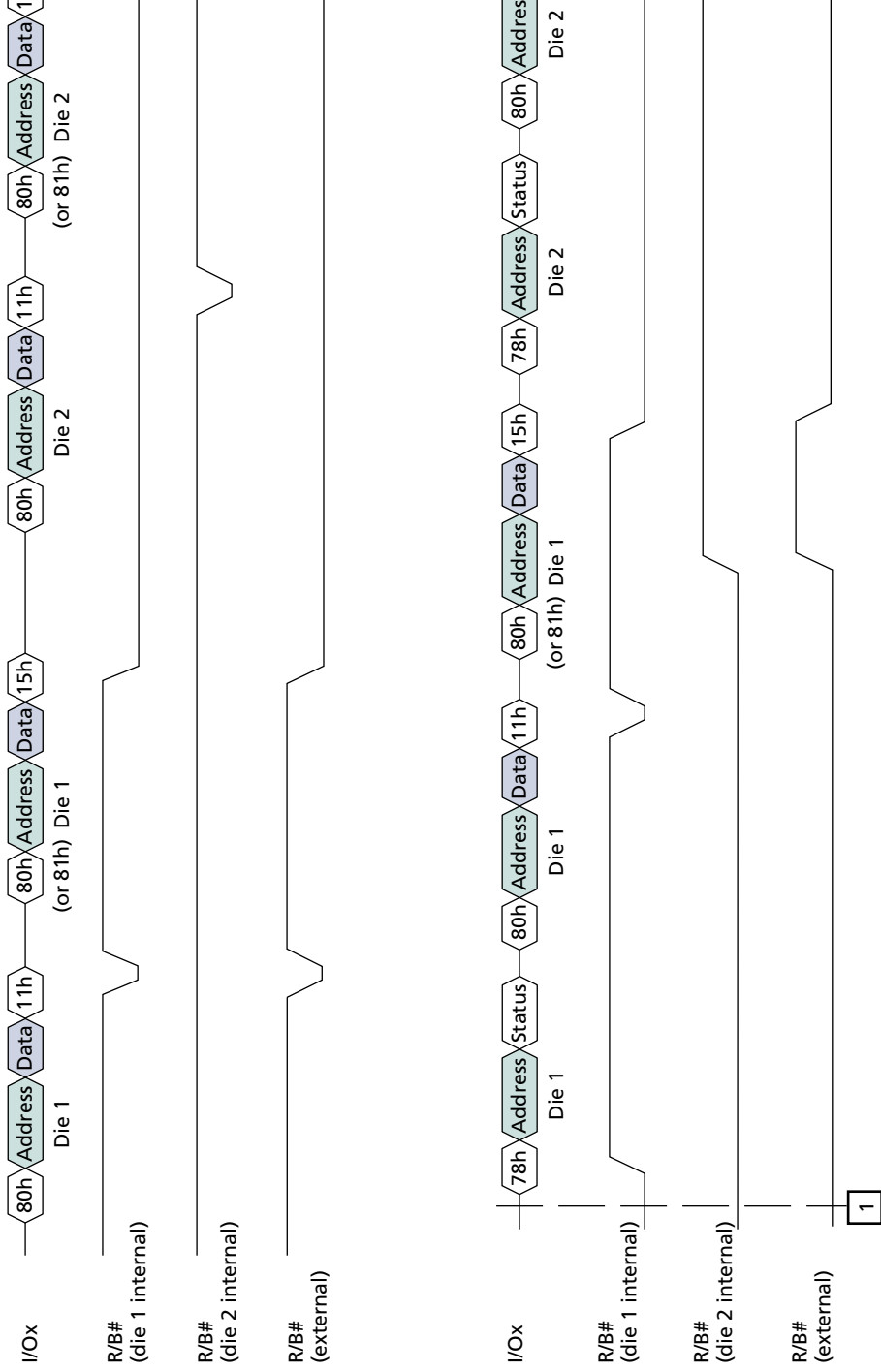

Figure 42: Interleaved TWO-PLANE PROGRAM PAGE CACHE MODE Operation with Status Register Monitor



Notes: 1. Two-plane addressing requirements apply.

Interleaved BLOCK ERASE Operations

Figures 43 and 44 show how to perform two types of interleaved BLOCK ERASE operations. In Figure 43, the R/B# signal is monitored for operation completion. In Figure 44, the TWO-PLANE/MULTIPLE-DIE READ STATUS (78h) command is used to monitor the status register for operation completion.

Figure 43: Interleaved BLOCK ERASE Operation with R/B# Monitoring

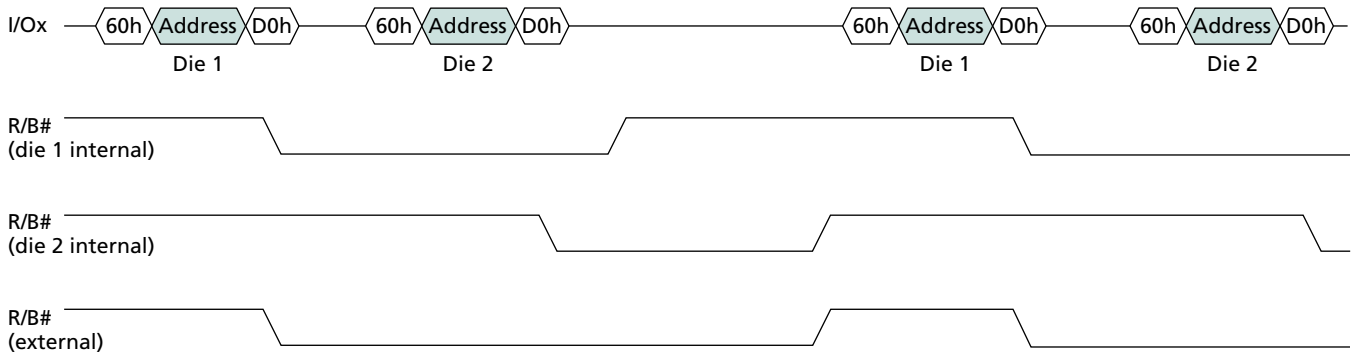
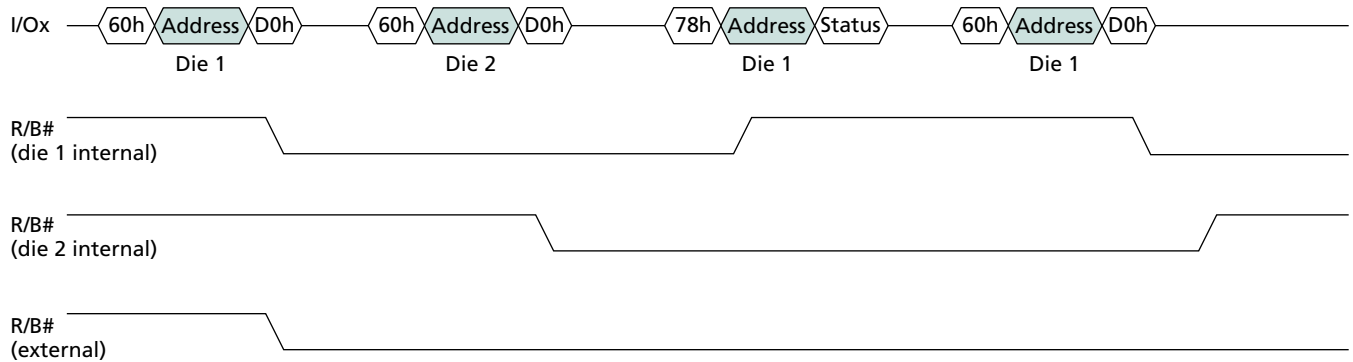

Figure 44: Interleaved BLOCK ERASE Operation with Status Register Monitoring



Interleaved TWO-PLANE BLOCK ERASE Operations

Figures 45 and 46 on page 55 show how to perform two types of interleaved BLOCK ERASE operations. In Figure 45, the R/B# signal is monitored for operation completion. In Figure 46, the TWO-PLANE/MULTIPLE-DIE READ STATUS (78h) command is used to monitor the status register for operation completion.

The interleaved TWO-PLANE BLOCK ERASE operation must meet two-plane addressing requirements. See “Two-Plane Addressing” on page 35 for details.

Figure 45: Interleaved TWO-PLANE BLOCK ERASE Operation with R/B# Monitoring

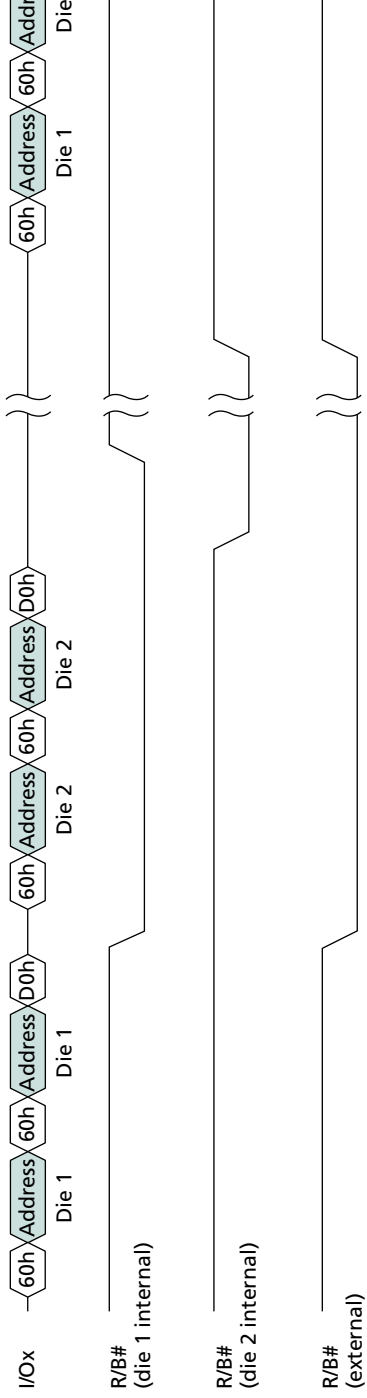

Notes: 1. Two-plane addressing requirements apply.

Figure 46: Interleaved TWO-PLANE BLOCK ERASE Operation with Status Register Monitoring

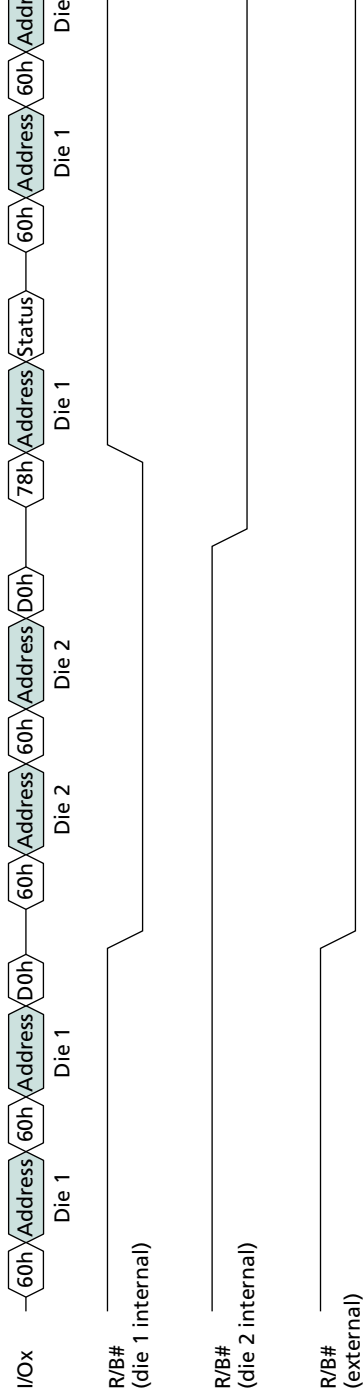

Notes: 1. Two-plane addressing requirements apply.

RESET Operation

RESET FFh

The RESET command is used to put the memory device into a known condition and to abort the command sequence in progress.

READ, PROGRAM, and ERASE commands can be aborted while the device is in the busy state. The contents of the memory location being programmed or the block being erased are no longer valid. The data may be partially erased or programmed, and is invalid. The command register is cleared and is ready for the next command. The data register and cache register contents are marked invalid.

The status register contains the value E0h when WP# is HIGH; otherwise it is written with a 60h value. R/B# goes LOW for t_{RST} after the RESET command is written to the command register (see Figure 47 and Table 10).

The RESET command must be issued to all CE#s after power-on. The device will be busy for a maximum of 1ms. Use of the TWO-PLANE/MULTIPLE-DIE READ STATUS (78h) command is prohibited during and following the initial RESET command and OTP operations.

Figure 47: RESET Operation

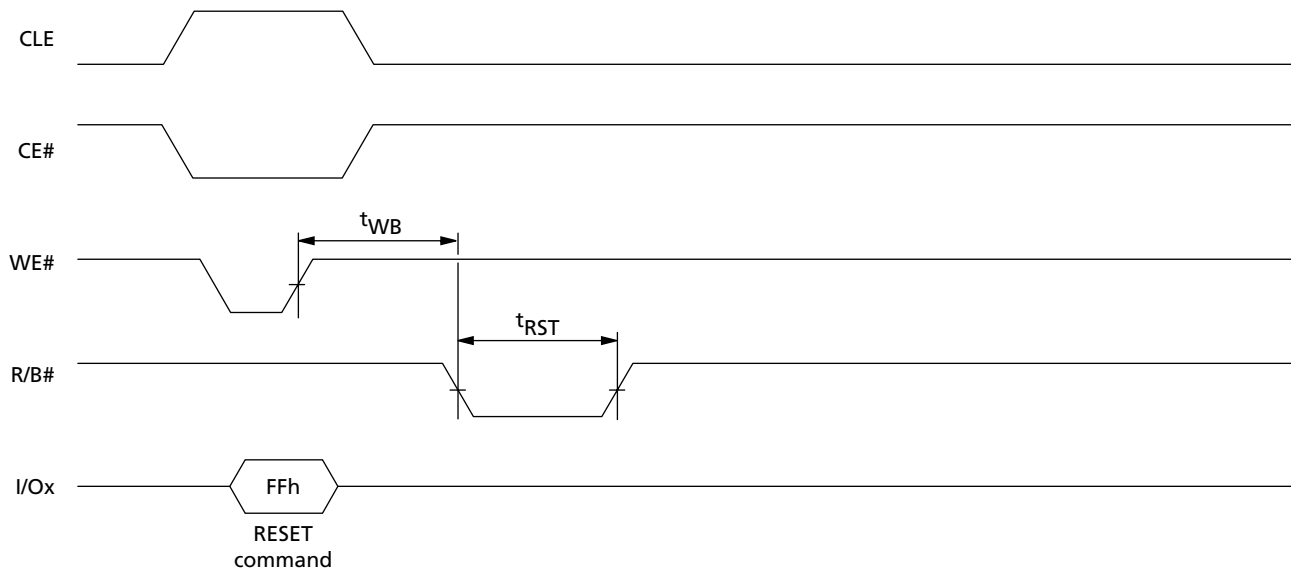

Table 10: Status Register Contents After RESET Operation

Condition	Status	Bit 7	Bit 6	Bit 5	Bit 4	Bit 3	Bit 2	Bit 1	Bit 0	Hex
WP# HIGH	Ready	1	1	1	0	0	0	0	0	E0h
WP# LOW	Ready and write protected	0	1	1	0	0	0	0	0	60h

WRITE PROTECT Operation

It is possible to enable and disable PROGRAM and ERASE commands using the WP# pin. Figures 48 through 51 illustrate the setup time (t_{WW}) required from WP# toggling until a PROGRAM or ERASE command is latched into the command register. After command cycle 1 is latched, the WP# pin must not be toggled until the command is complete and the device is ready (status register bit 5 is "1").

Figure 48: ERASE Enable

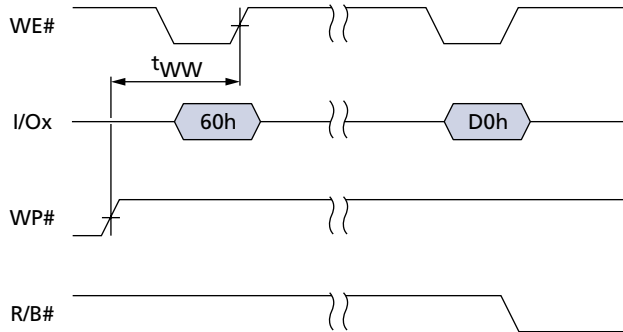

Figure 49: ERASE Disable

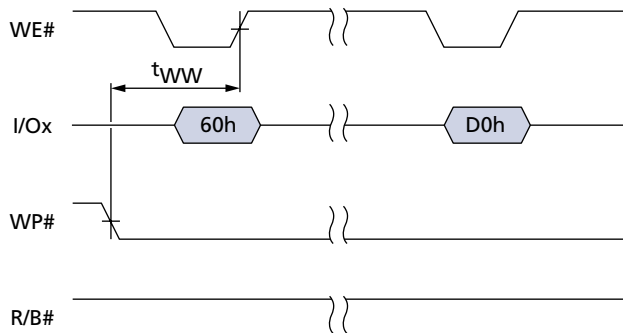

Figure 50: PROGRAM Enable

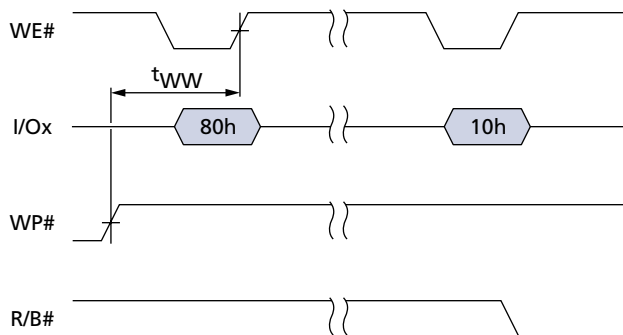
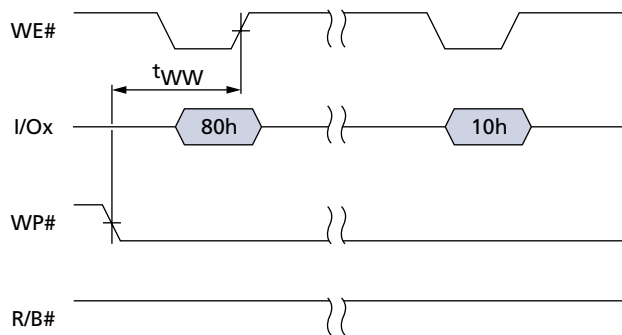

Figure 51: PROGRAM Disable



Error Management

This NAND Flash device is specified to have a minimum of 4,016 valid blocks (NVB) out of every 4,096 total available blocks. This means the devices may have blocks that are invalid when shipped from the factory. An invalid block is one that contains one or more bad bits. Additional bad blocks may develop with use. However, the total number of available blocks will not fall below NVB during the endurance life of the product.

Although NAND Flash memory devices may contain bad blocks, they can be used quite reliably in systems that provide bad-block management and error correction algorithms. This type of software environment ensures data integrity.

Internal circuitry isolates each block from other blocks, so the presence of a bad block does not affect the operation of the rest of the NAND Flash array.

The first block (physical block address 00h) for each CE# is guaranteed to be valid with ECC (up to 1,000 PROGRAM/ERASE cycles) when shipped from the factory. This provides a reliable location for storing boot code and critical boot information.

NAND Flash devices are shipped from the factory erased. The factory identifies invalid blocks before shipping by programming data other than FFh into the first spare location (column address 2,048) of the first or second page of each bad block.

System software should check the first spare address on the first and second page of each block prior to performing any PROGRAM or ERASE operations on the NAND Flash device. A bad-block table can then be created, allowing system software to map around these areas. Factory testing is performed under worst-case conditions. Because blocks marked “bad” may be marginal, it may not be possible to recover this information if the block is erased.

Over time, some memory locations may fail to program or erase properly. In order to ensure that data is stored properly over the life of the NAND Flash device, the following precautions are required:

- Check status after a PROGRAM, ERASE, or INTERNAL DATA MOVE operation.
- Under typical use conditions, utilize a minimum of 1-bit ECC per 528 bytes of data.
- Use bad-block management and a wear-leveling algorithm.

Electrical Characteristics

Stresses greater than those listed in Table 11 may cause permanent damage to the device. This is a stress rating only, and functional operation of the device at these or any other conditions above those indicated in the operational sections of this specification is not guaranteed. Exposure to absolute maximum rating conditions for extended periods may affect reliability.

Table 11: Absolute Maximum Ratings
Voltage on any pin relative to Vss

Parameter/Condition		Symbol	Min	Max	Unit
Voltage input	MT29FxG08xAA	V _{IN}	-0.6	+4.6	V
Vcc supply voltage	MT29FxG08xAA	V _{CC}	-0.6	+4.6	V
Storage temperature		T _{STG}	-65	+150	°C
Short circuit output current, I/Os			-	5	mA

Table 12: Recommended Operating Conditions

Parameter/Condition		Symbol	Min	Typ	Max	Unit
Operating temperature	Commercial	T _A	0	-	+70	°C
	Extended		-40	-	+85	
Vcc supply voltage	MT29FxG08xAA	V _{CC}	2.7	3.3	3.6	V
Ground supply voltage		V _{SS}	0	0	0	V

Vcc Power Cycling

Micron NAND Flash devices are designed to prevent data corruption during power transitions. VCC is internally monitored. When VCC goes below approximately 2.0V, PROGRAM and ERASE functions are disabled. WP# provides additional hardware protection. WP# should be kept at VIL during power cycling. When VCC reaches 2.5V, 10µs should be allowed for the NAND Flash to initialize before executing any commands (see Figure 52).

The RESET command must be issued to all CE#s after power-on. The device will be busy for a maximum of 1ms.

Figure 52: AC Waveforms During Power Transitions

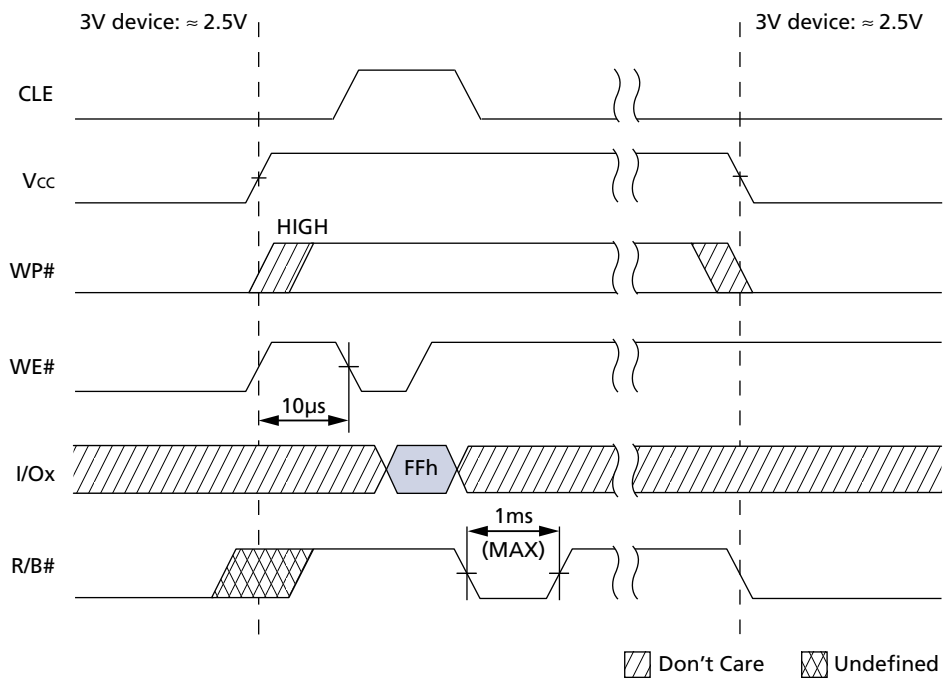

Table 13: M29FxGxxxAA 3V Device DC and Operating Characteristics

Parameter	Conditions	Symbol	Min	Typ	Max	Unit	
Sequential read current	^t RC = 25ns; CE# = V _{IL} ; I _{OUT} = 0mA	I _{CC1}	–	25	35	mA	
Program current	–	I _{CC2}	–	25	35	mA	
Erase current	–	I _{CC3}	–	25	35	mA	
Standby current (TTL)	CE# = V _{IH} ; WP# = 0V/V _{CC}	I _{SB1}	–	–	1	mA	
Standby current (CMOS)							
	MT29F4G08AAA	CE# = V _{CC} - 0.2V; WP# = 0V/V _{CC}	I _{SB2}	–	10	50	μA
	MT29F8G08BAA			–	20	100	μA
	MT29F8G08DAA			–	20	100	μA
	MT29F16G08FAA			–	40	200	μA
Input leakage current							
	MT29F4G08AAA	V _{IN} = 0V to V _{CC}	I _{LI}	–	–	±10	μA
	MT29F8G08BAA			–	–	±20	μA
	MT29F8G08DAA			–	–	±20	μA
	MT29F16G08FAA			–	–	±40	μA
Output leakage current							
	MT29F4G08AAA	V _{OUT} = 0V to V _{CC}	I _{LO}	–	–	±10	μA
	MT29F8G08BAA			–	–	±20	μA
	MT29F8G08DAA			–	–	±20	μA
	MT29F16G08FAA			–	–	±40	μA
Input high voltage	I/O[7:0], CE#, CLE, ALE, WE#, RE#, WP#, R/B#	V _{IH}	0.8 x V _{CC}	–	V _{CC} + 0.3	V	
Input low voltage (all inputs)	–	V _{IL}	–0.3	–	0.2 x V _{CC}	V	
Output high voltage	I _{OH} = –400μA	V _{OH}	2.4	–	–	V	
Output low voltage	I _{OL} = 2.1mA	V _{OL}	–	–	0.4	V	
Output low current (R/B#)	V _{OL} = 0.4V	I _{OL} (R/B#)	8	10	–	mA	

Table 14: Valid Blocks

Parameter	Symbol	Device	Min	Max	Unit	Notes
Valid block number	N _{VB}	MT29F4G08AAA	4,016	4,096	blocks	1, 2
		MT29F8G08BAA	8,032	8,192		3
		MT29F8G08DAA	8,032	8,192		3
		MT29F16G08FAA	16,064	16,384		3

- Notes:
- Invalid blocks are blocks that contain one or more bad bits. The device may contain bad blocks upon shipment. Additional bad blocks may develop over time; however, the total number of available blocks will not drop below N_{VB} during the endurance life of the device. Do not erase or program blocks marked invalid by the factory.
 - Block 00h (the first block) is guaranteed to be valid up to 1,000 PROGRAM/ERASE cycles.
 - Each 4Gb section has a maximum of 80 invalid blocks.

Table 15: Capacitance

Description	Symbol	Device	Max	Unit	Notes
Input capacitance	C _{IN}	MT29F4G08AAA	10	pF	1, 2
		MT29F8G08BAA	20		
		MT29F8G08DAA	20		
		MT29F16G08FAA	40		
Input/output capacitance (I/O)	C _{IO}	MT29F4G08AAA	10	pF	1, 2
		MT29F8G08BAA	20		
		MT29F8G08DAA	20		
		MT29F16G08FAA	40		

- Notes: 1. These parameters are verified in device characterization and are not 100 percent tested.
2. Test conditions: T_C = 25°C; f = 1 MHz; V_{IN} = 0V.

Table 16: Test Conditions

Parameter		Value	Notes
Input pulse levels	MT29FxG08xAA	0.0V to V _{CC}	
Input rise and fall times		5ns	
Input and output timing levels		V _{CC} /2	
Output load		1 TTL GATE and CL = 50pF	1

- Notes: 1. Verified in device characterization; not 100 percent tested.

Table 17: AC Characteristics: Command, Data, and Address Input

Parameter	Symbol	Cache Mode ¹		Standard Mode		Unit	Notes
		Min	Max	Min	Max		
ALE to data start	^t ADL	70	–	70	–	ns	2
ALE hold time	^t ALH	10	–	5	–	ns	
ALE setup time	^t ALS	25	–	10	–	ns	
CE# hold time	^t CH	10	–	5	–	ns	
CLE hold time	^t CLH	10	–	5	–	ns	
CLE setup time	^t CLS	25	–	10	–	ns	
CE# setup time	^t CS	35	–	15	–	ns	
Data hold time	^t DH	10	–	5	–	ns	
Data setup time	^t DS	20	–	10	–	ns	
WRITE cycle time	^t WC	45	–	25	–	ns	
WE# pulse width HIGH	^t WH	15	–	10	–	ns	
WE# pulse width	^t WP	25	–	12	–	ns	
WP# setup time	^t WW	30	–	30	–	ns	

- Notes: 1. For PAGE READ CACHE MODE and PROGRAM PAGE CACHE MODE operations, cache mode timing applies.
2. Timing for ^tADL begins in the ADDRESS cycle on the final rising edge of WE# and ends with the first rising edge of WE# for data input.

Table 18: AC Characteristics: Normal Operation

Parameter	Symbol	Cache Mode		Standard Mode		Unit	Notes
		Min	Max	Min	Max		
ALE to RE# delay	^t AR	10	–	10	–	ns	
CE# access time	^t CEA	–	45	–	25	ns	1
CE# HIGH to output High-Z	^t CHZ	–	45	–	30	ns	2
CLE to RE# delay	^t CLR	10	–	10	–	ns	
CE# HIGH to output hold	^t COH	15	–	15	–	ns	
Cache busy in page read cache mode (first 31h)	^t DCBSYR1	–	3	–	–	μs	
Cache busy in page read cache mode (next 31h and 3Fh)	^t DCBSYR2	^t DCBSYR1	25	–	–	μs	
Output High-Z to RE# LOW	^t IR	0	–	0	–	ns	1
Data transfer from Flash array to data register	^t R	–	25	–	25	μs	
READ cycle time	^t RC	50	–	25	–	ns	1
RE# access time	^t REA	–	30	–	20	ns	1
RE# HIGH hold time	^t REH	15	–	10	–	ns	1
RE# HIGH to output hold	^t RHOH	22	–	22	–	ns	
RE# HIGH to WE# LOW	^t RHW	100	–	100	–	ns	
RE# HIGH to output High-Z	^t RHZ	–	100	–	100	ns	2
RE# LOW to output hold	^t RLOH	5	–	5	–	ns	
RE# pulse width	^t RP	25	–	12	–	ns	1
Ready to RE# LOW	^t RR	20	–	20	–	ns	
Reset time (READ/PROGRAM/ERASE)	^t RST	–	5/10/500	–	5/10/500	μs	3
WE# HIGH to busy	^t WB	–	100	–	100	ns	4
WE# HIGH to RE# LOW	^t WHR	60	–	60	–	ns	

- Notes:
1. For PAGE READ CACHE MODE and PROGRAM PAGE CACHE MODE operations, cache mode timing applies.
 2. Transition is measured $\pm 200\text{mV}$ from steady-state voltage with load. This parameter is sampled and not 100 percent tested.
 3. The first time the RESET (FFh) command is issued while the device is idle, the device will go busy for a maximum of 1ms. Thereafter, the device goes busy for maximum 5μs.
 4. Do not issue a new command during ^tWB, even if R/B# is ready.

Table 19: PROGRAM/ERASE Characteristics

Symbol	Parameter	Typ	Max	Unit	Notes
NOP	Number of partial page programs	–	4	cycles	1
^t BERS	BLOCK ERASE operation time	1.5	2	ms	
^t CBSY	Busy time for PROGRAM CACHE operation	3	600	μs	2
^t DBSY	Busy time for TWO-PLANE PROGRAM PAGE operation	0.5	1	μs	
^t LPROG	LAST PAGE PROGRAM operation time	–	–	–	3
^t OBSY	Busy time for OTP DATA PROGRAM operation if OTP is protected	–	25	μs	
^t PROG	PAGE PROGRAM operation time	220	600	μs	4

- Notes:
1. Four total partial-page programs to the same page.
 2. ^tCBSY MAX time depends on timing between internal program completion and data-in.
 3. ^tLPROG = ^tPROG (last page) + ^tPROG (last - 1 page) - command load time (last page) - address load time (last page) - data load time (last page).
 4. Typical ^tPROG time may increase for two-plane operations.

Timing Diagrams

Figure 53: COMMAND LATCH Cycle

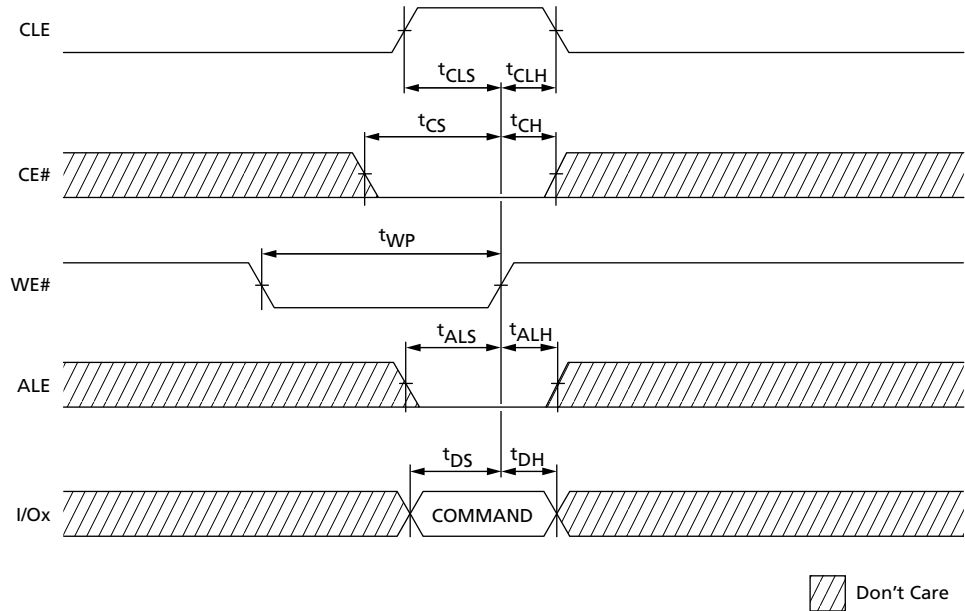

Figure 54: ADDRESS LATCH Cycle

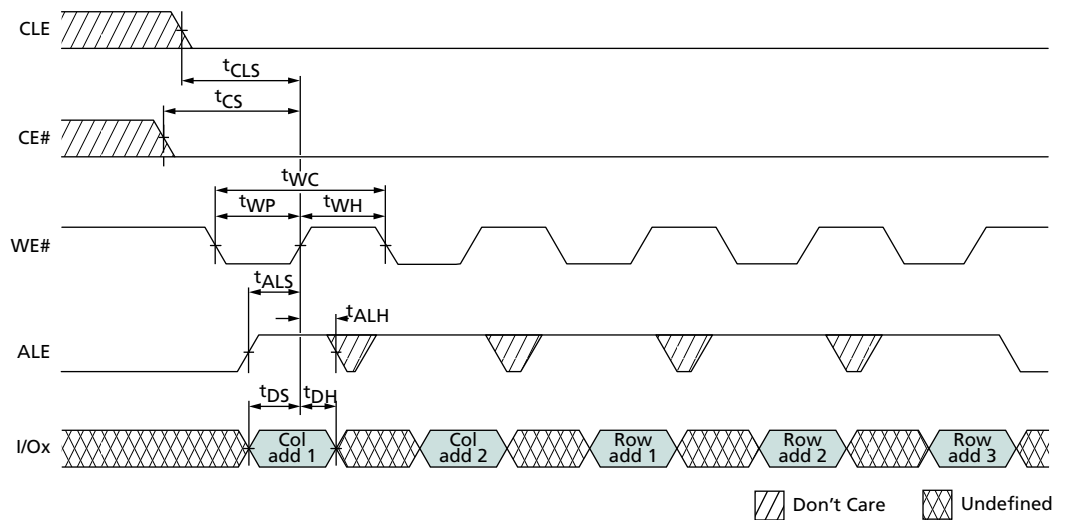
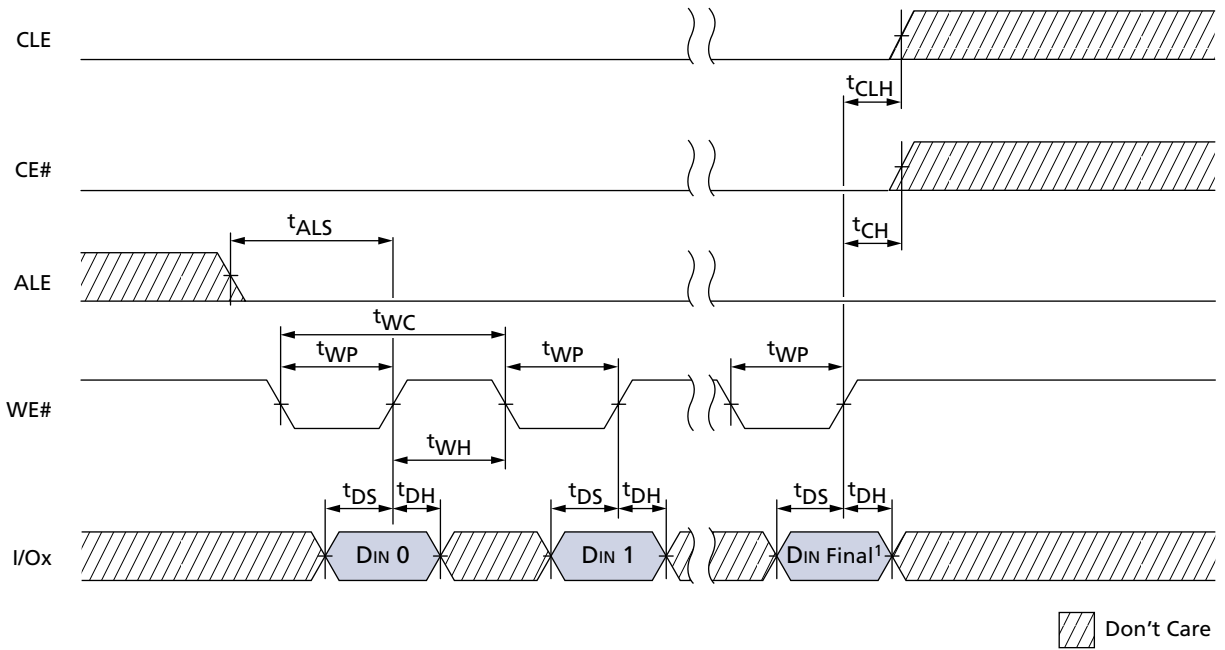
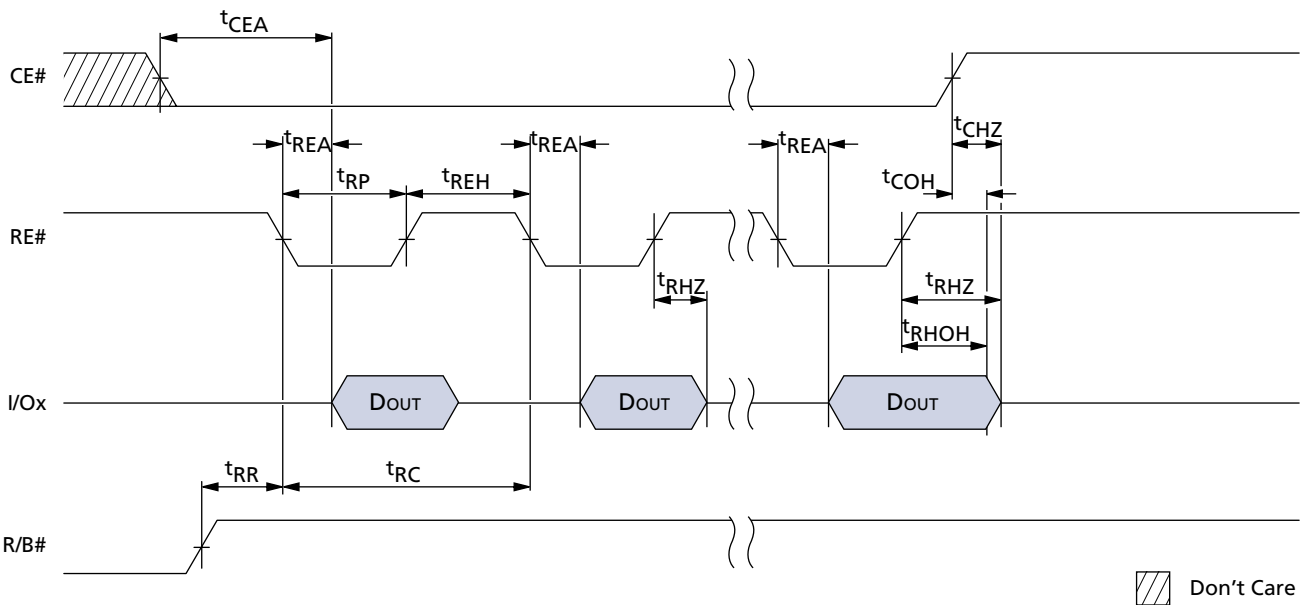

Figure 55: INPUT DATA LATCH Cycle



Notes: 1. DIN Final = 2,111 (x8).

Figure 56: SERIAL ACCESS Cycle After READ



Note: Use this timing diagram for $t_{RC} \geq 30\text{ns}$.

Figure 57: SERIAL ACCESS Cycle After READ (EDO Mode)

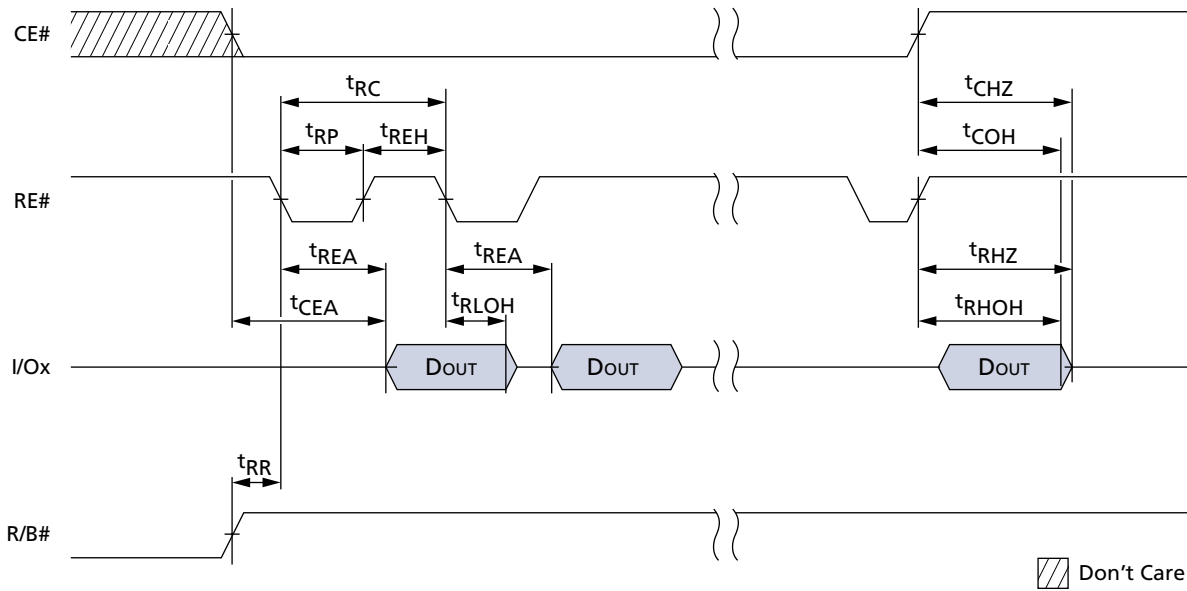

Note: Use this timing diagram for $t_{RC} < 30\text{ns}$.

Figure 58: READ STATUS Operation

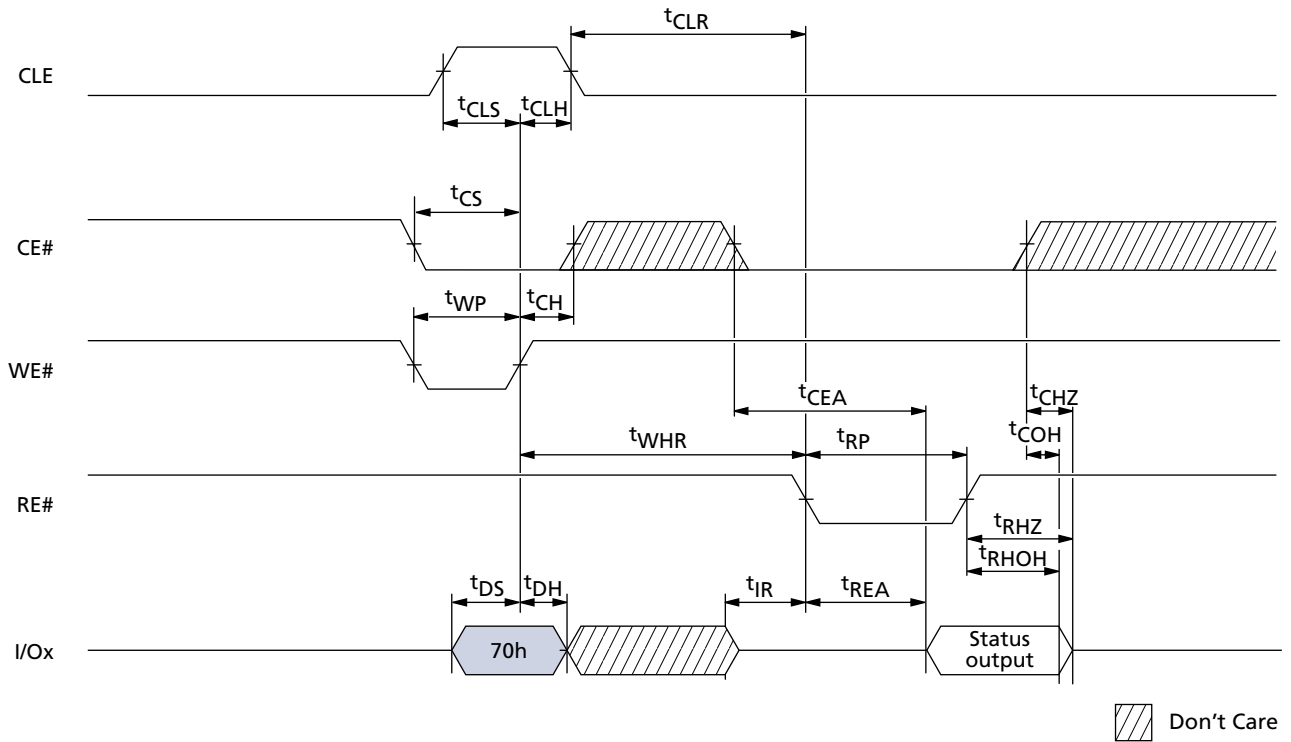

Figure 59: TWO-PLANE/MULTIPLE-DIE READ STATUS Operation

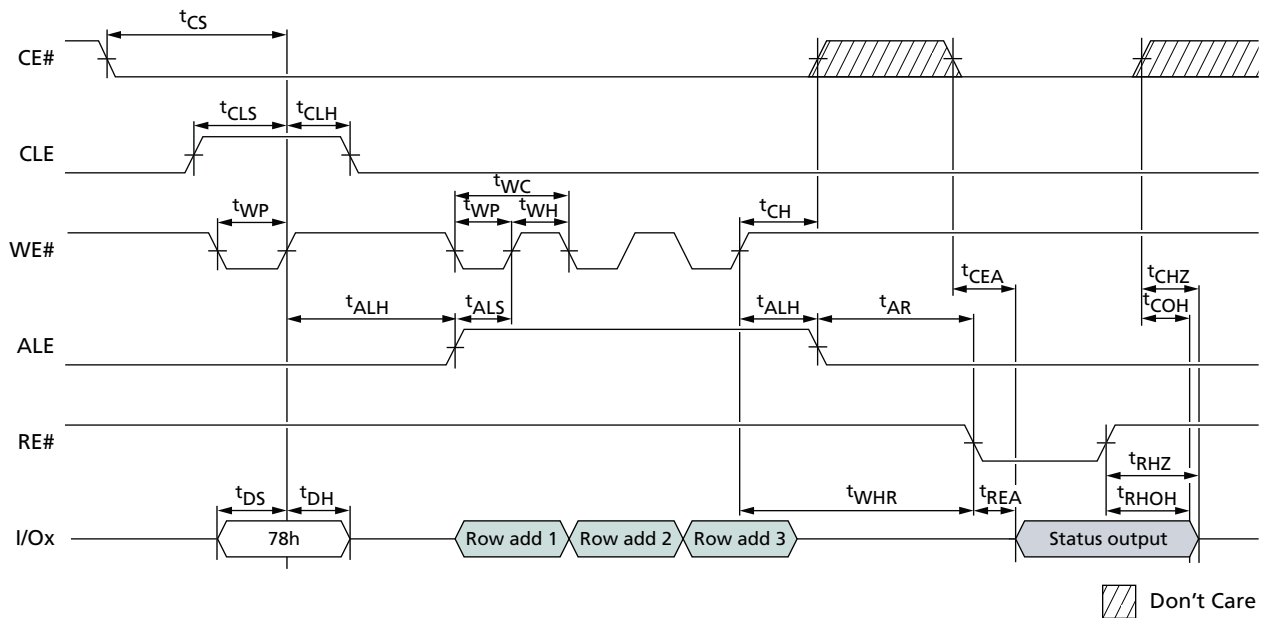

Figure 60: PAGE READ Operation

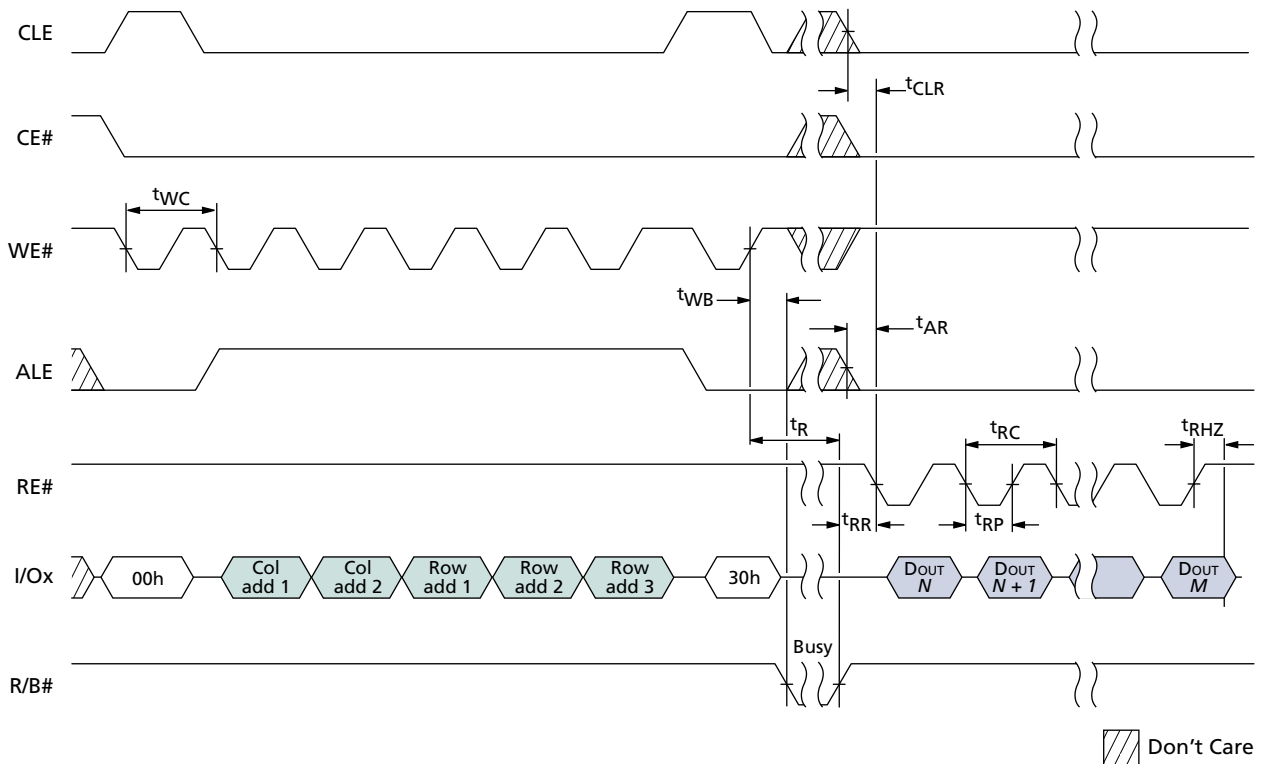

Figure 61: READ Operation with CE# "Don't Care"

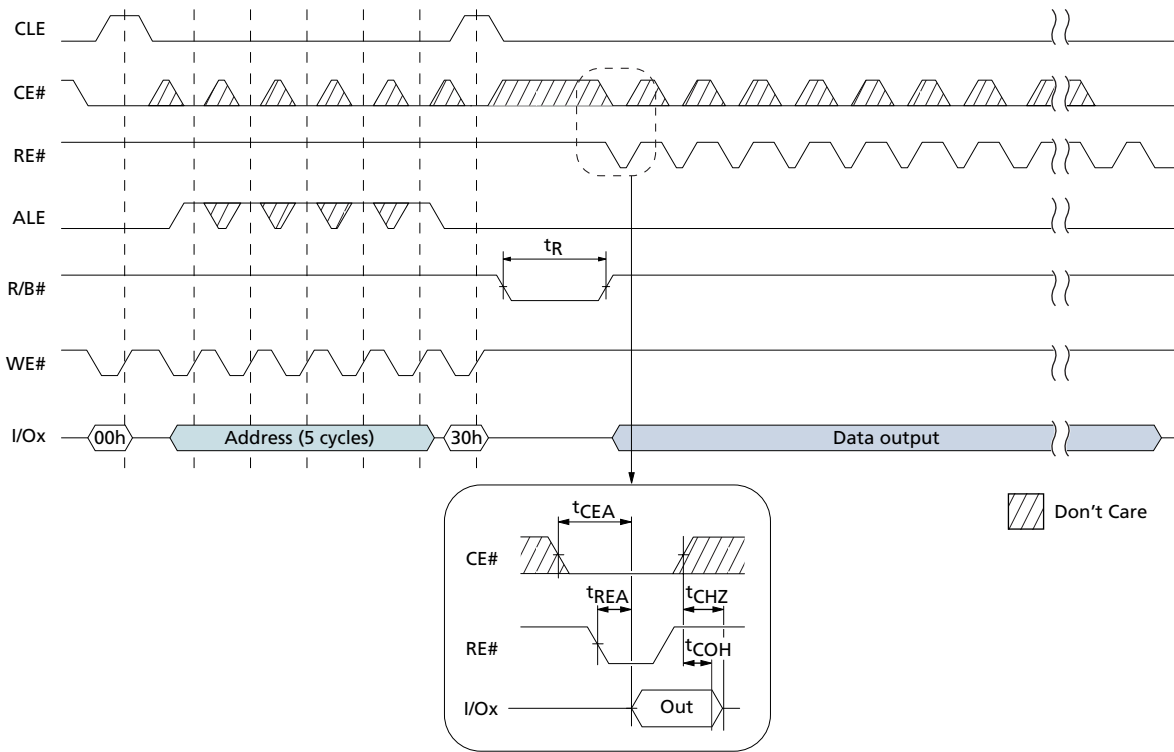

Figure 62: RANDOM DATA READ Operation

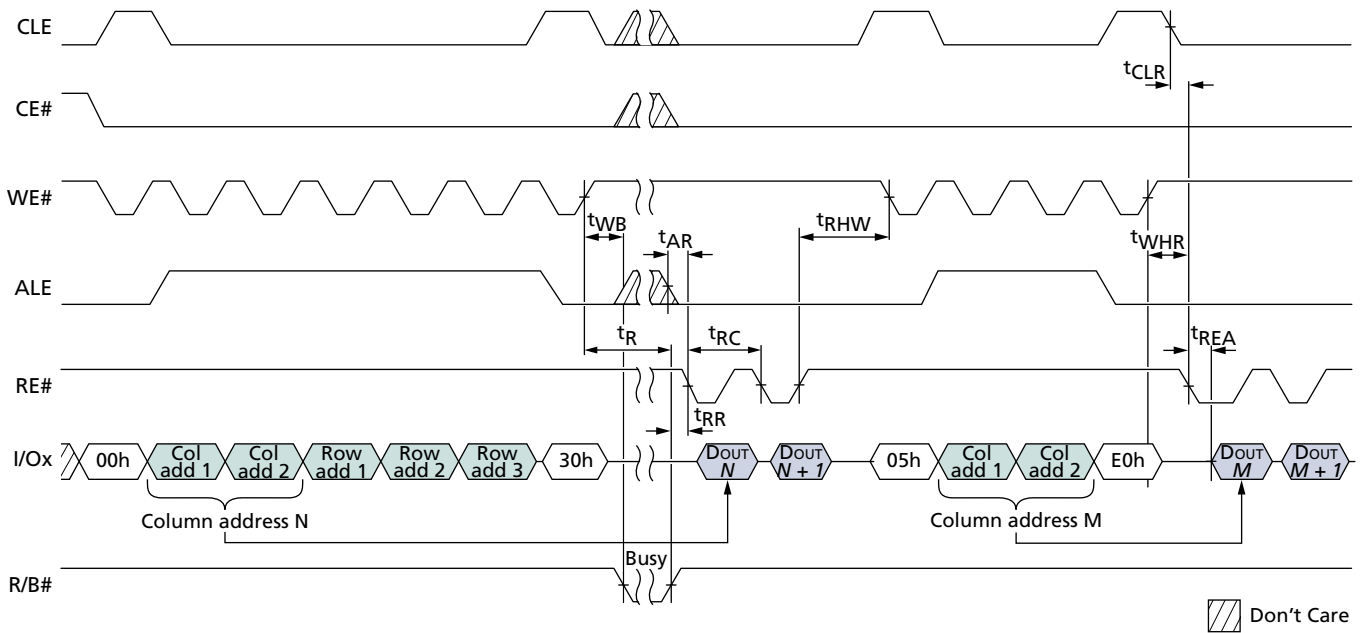
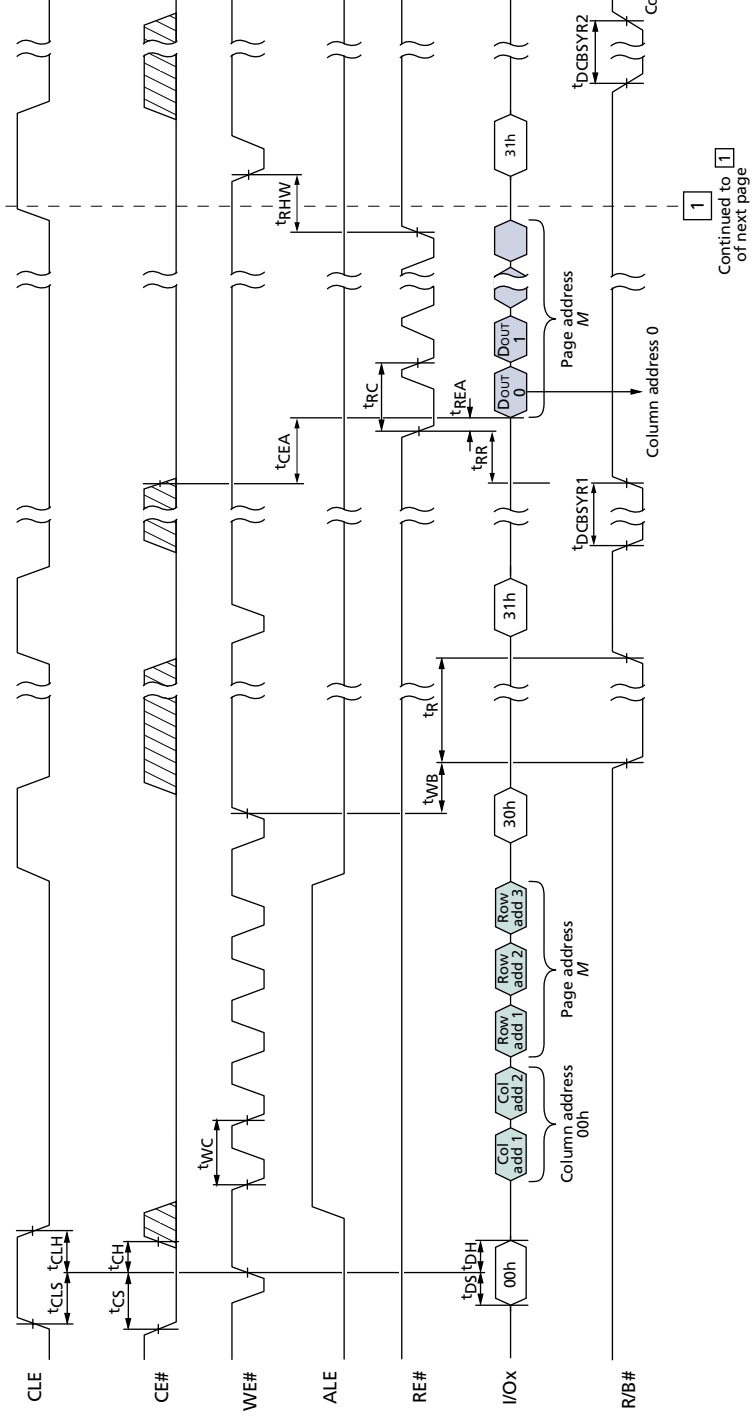
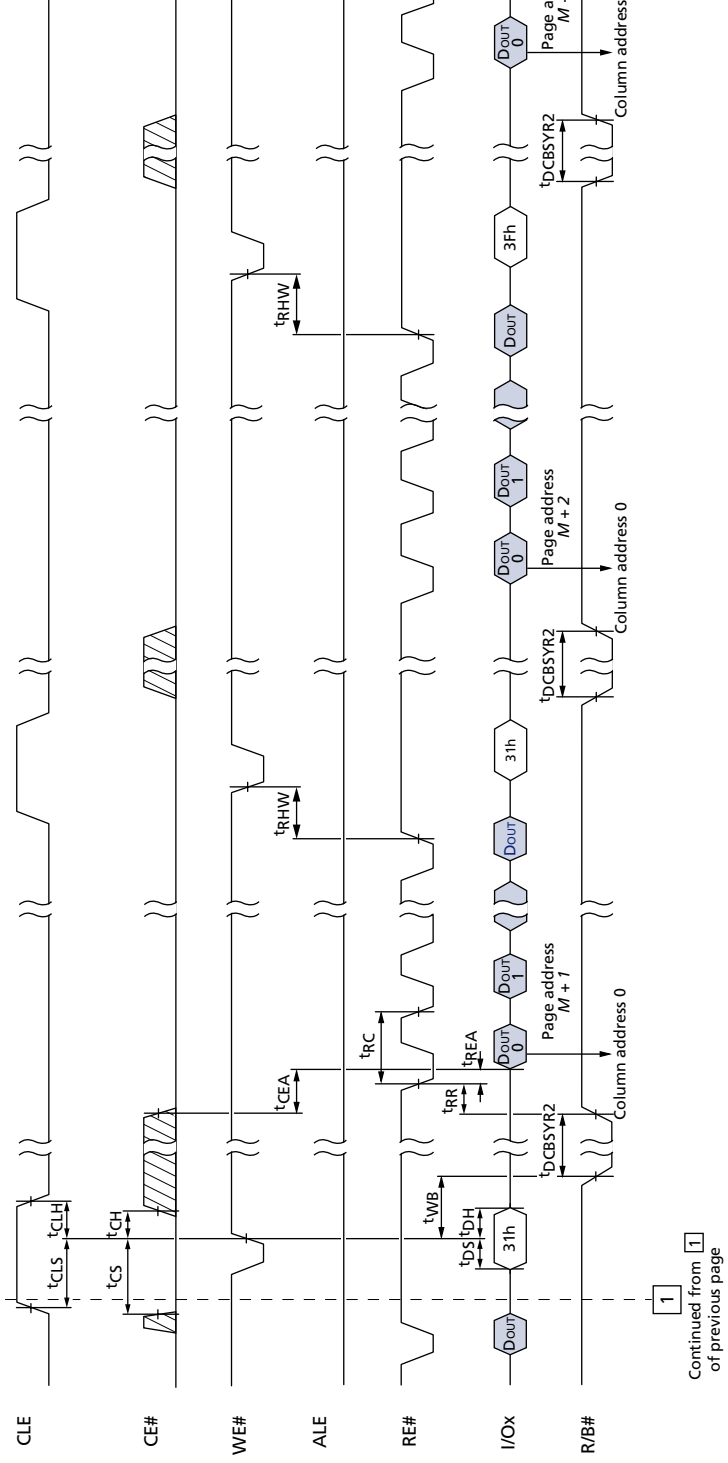

Figure 63: PAGE READ CACHE MODE Operation, Part 1 of 2



Continued to **1**
of next page

Figure 64: PAGE READ CACHE MODE Operation, Part 2 of 2



Continued from 1
of previous page

Figure 65: PAGE READ CACHE MODE Operation without R/B#, Part 1 of 2

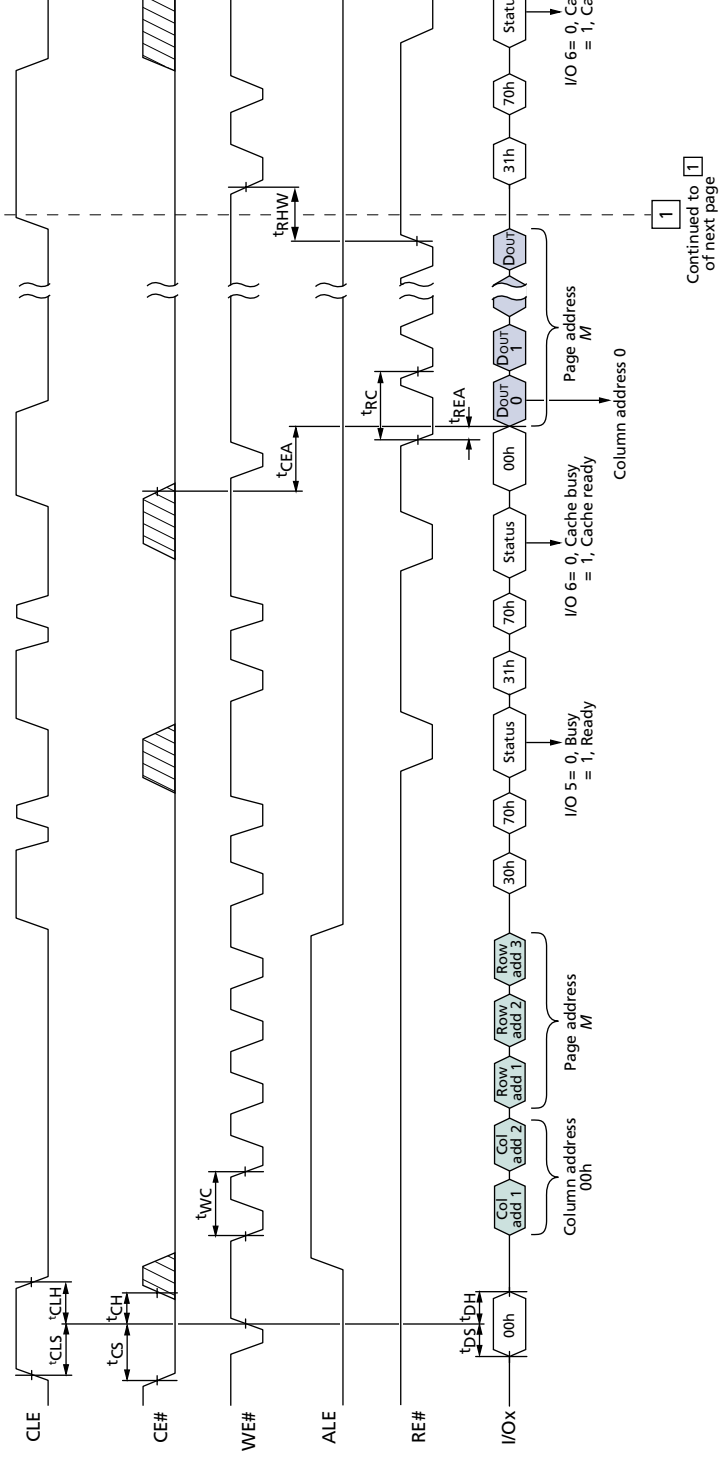

Continued to **1**
of next page

Figure 66: PAGE READ CACHE MODE Operation without R/B#, Part 2 of 2

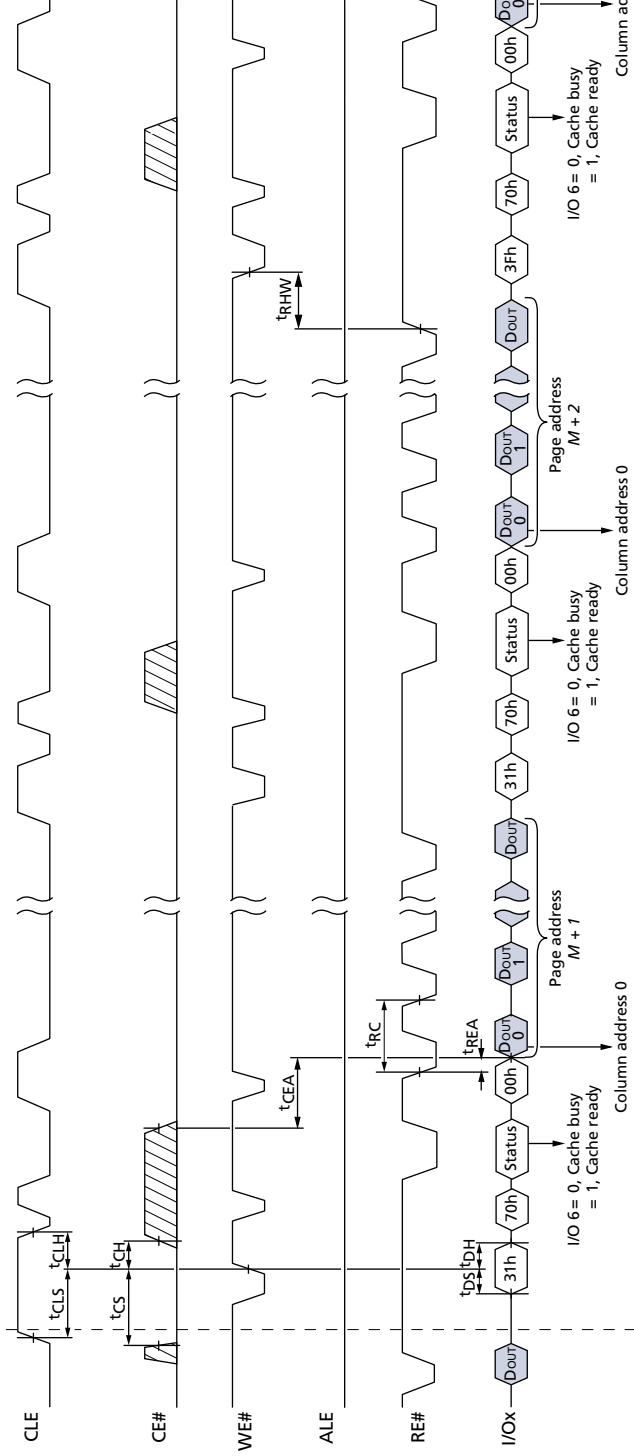

Continued from 1
of previous page

Figure 67: READ ID Operation

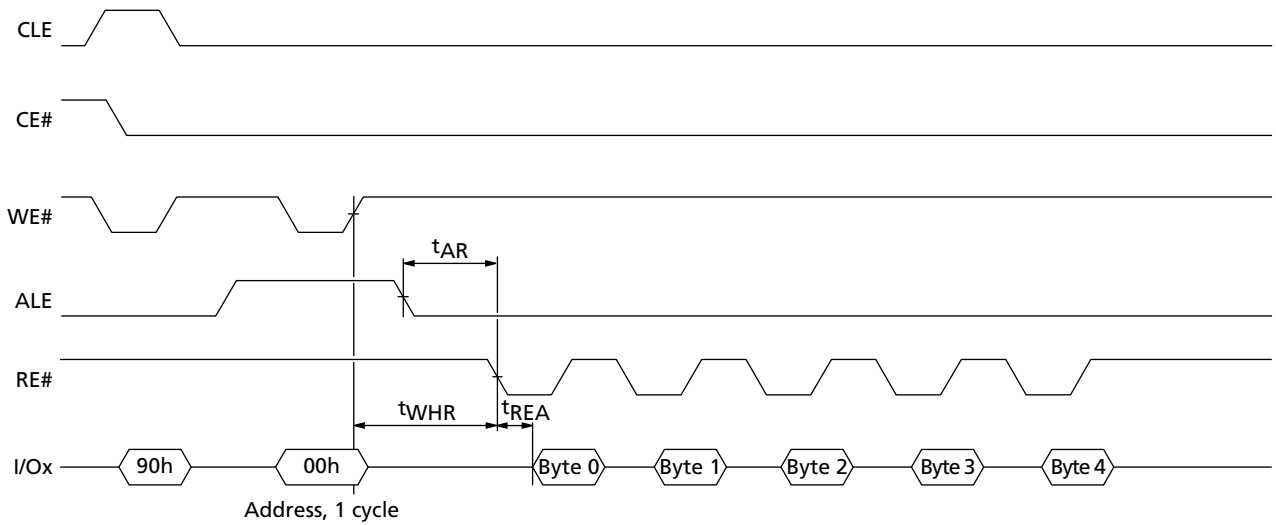

Note: See Table 8 on page 25 for actual values.

Figure 68: PROGRAM PAGE Operation

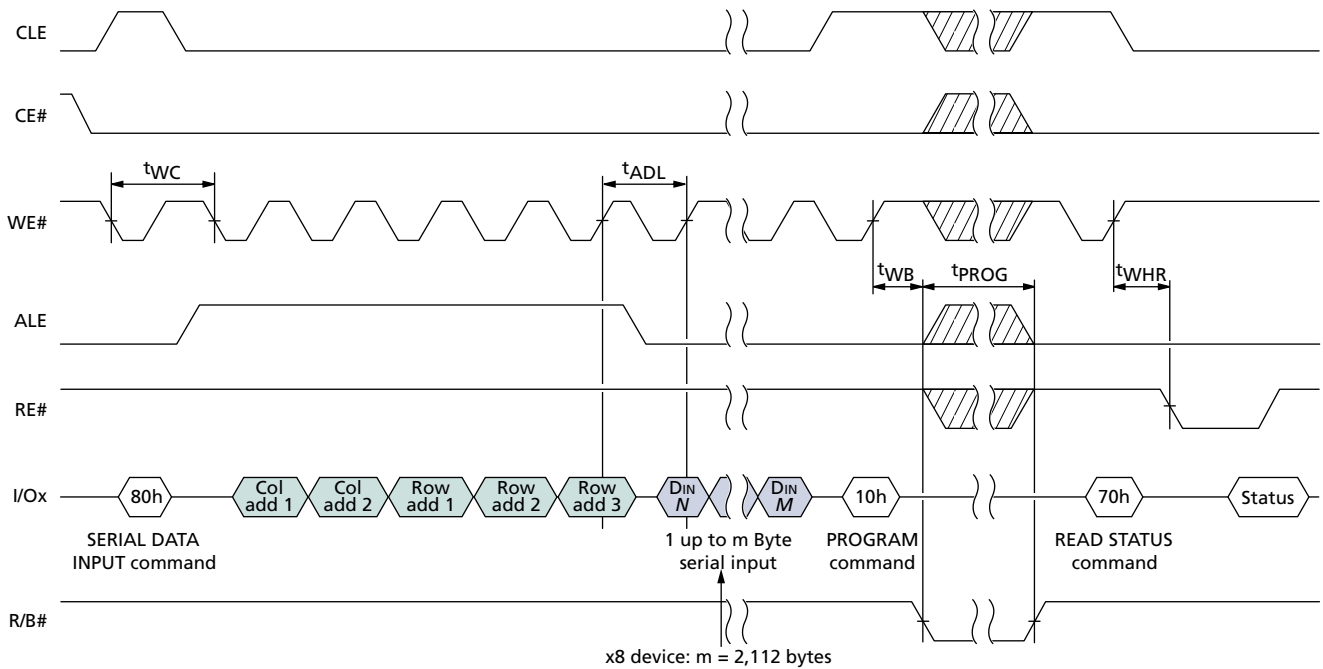

x8 device: $m = 2,112$ bytes

Don't Care

Figure 69: Program Operation with CE# "Don't Care"

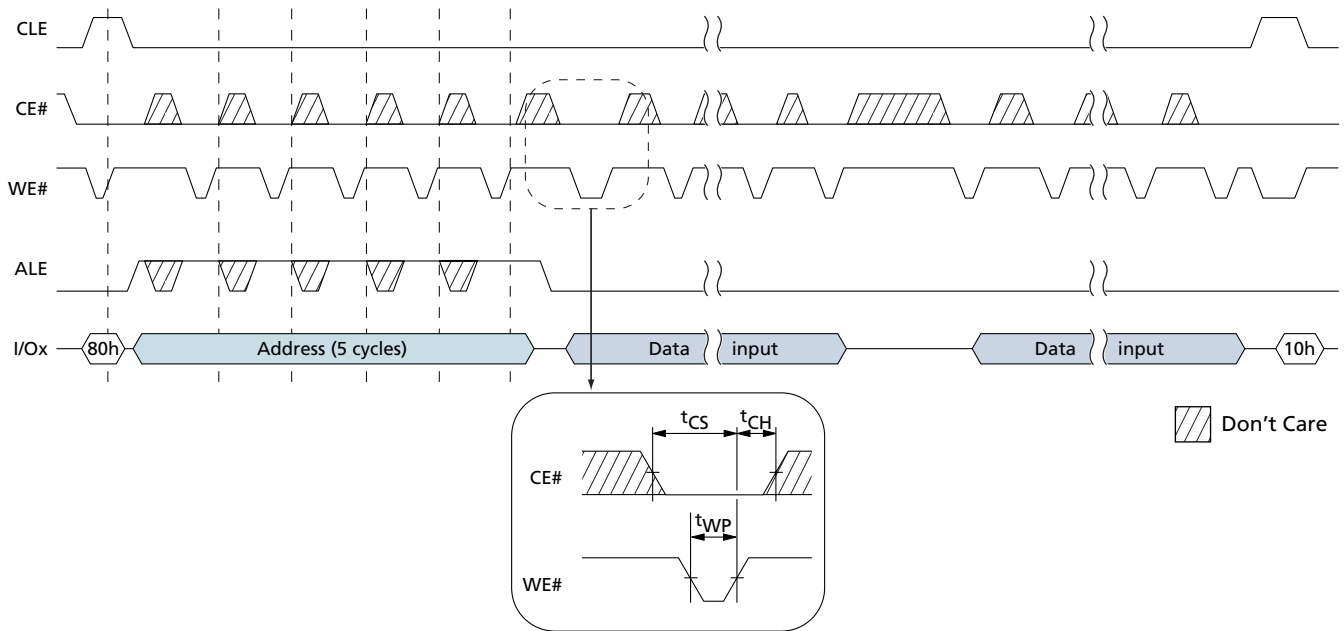

Figure 70: PROGRAM PAGE Operation with RANDOM DATA INPUT

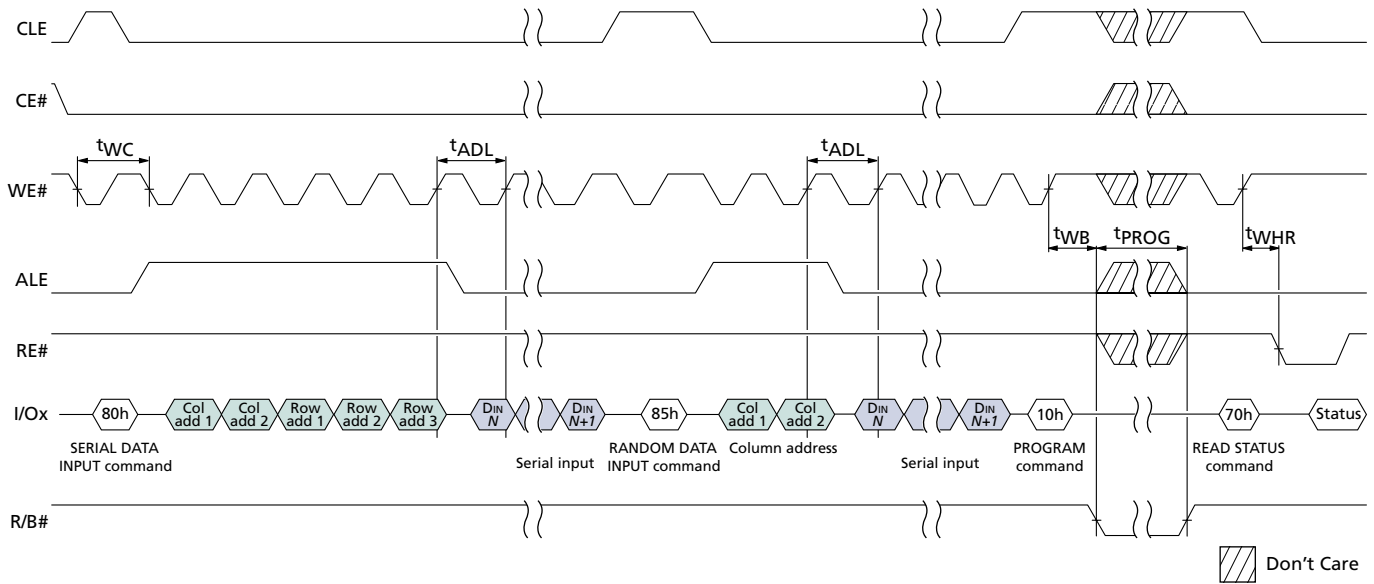
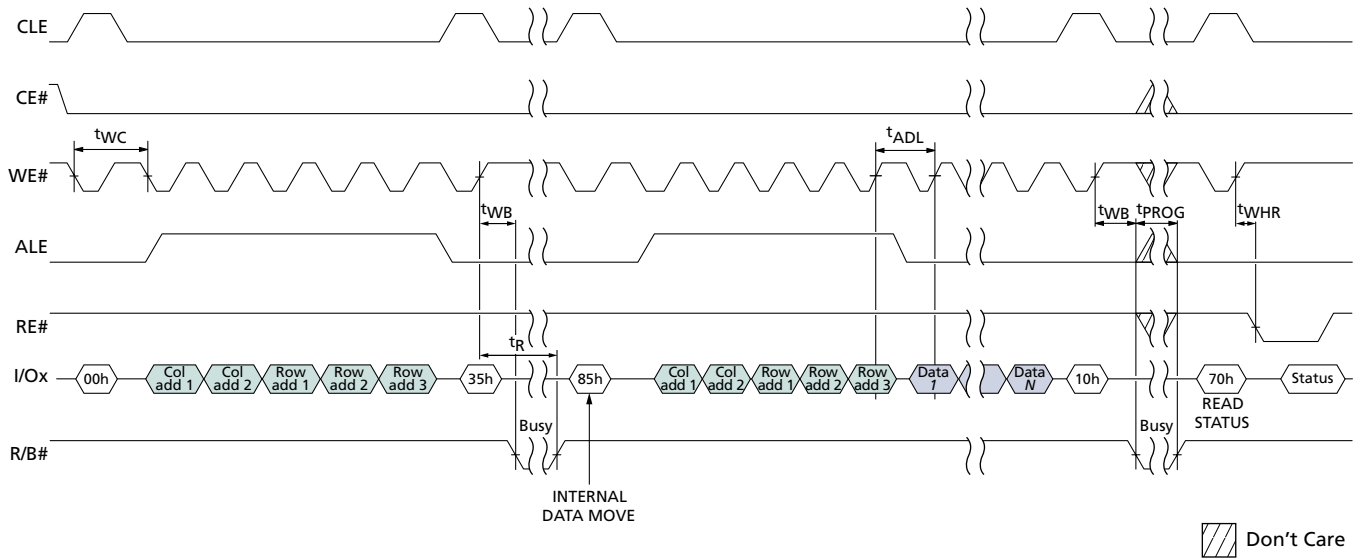

Figure 71: INTERNAL DATA MOVE Operation



Note: INTERNAL DATA MOVE operations are only supported within the plane from which data is read.

Figure 72: PROGRAM PAGE CACHE MODE Operation

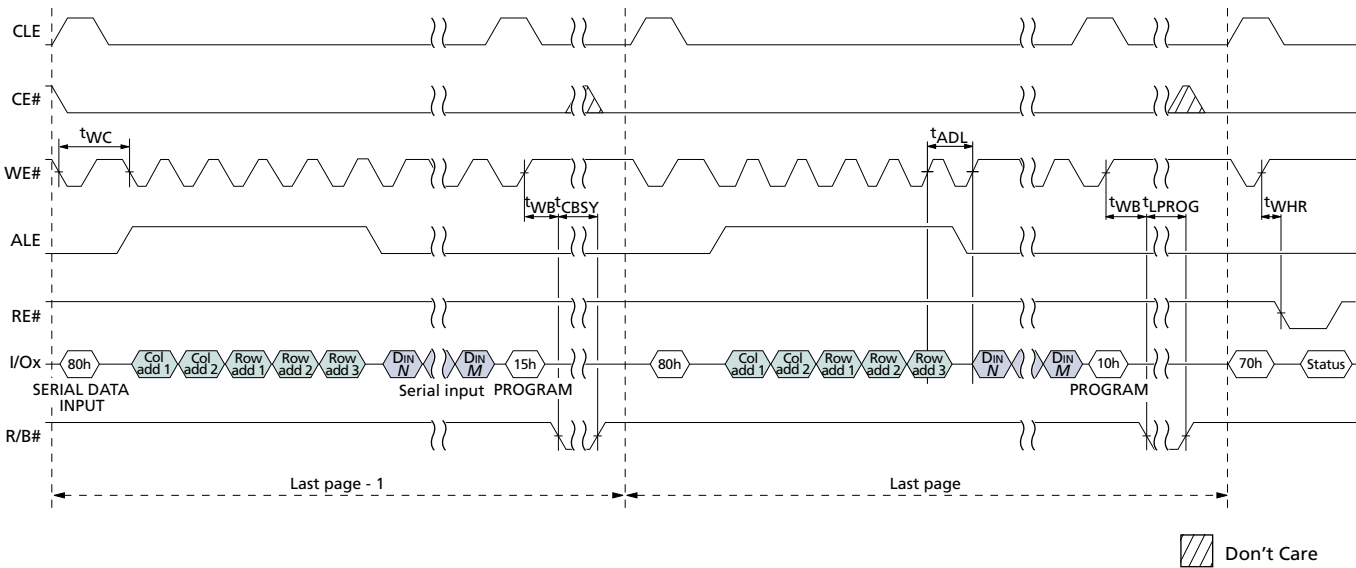

Figure 73: PROGRAM PAGE CACHE MODE Operation Ending on 15h

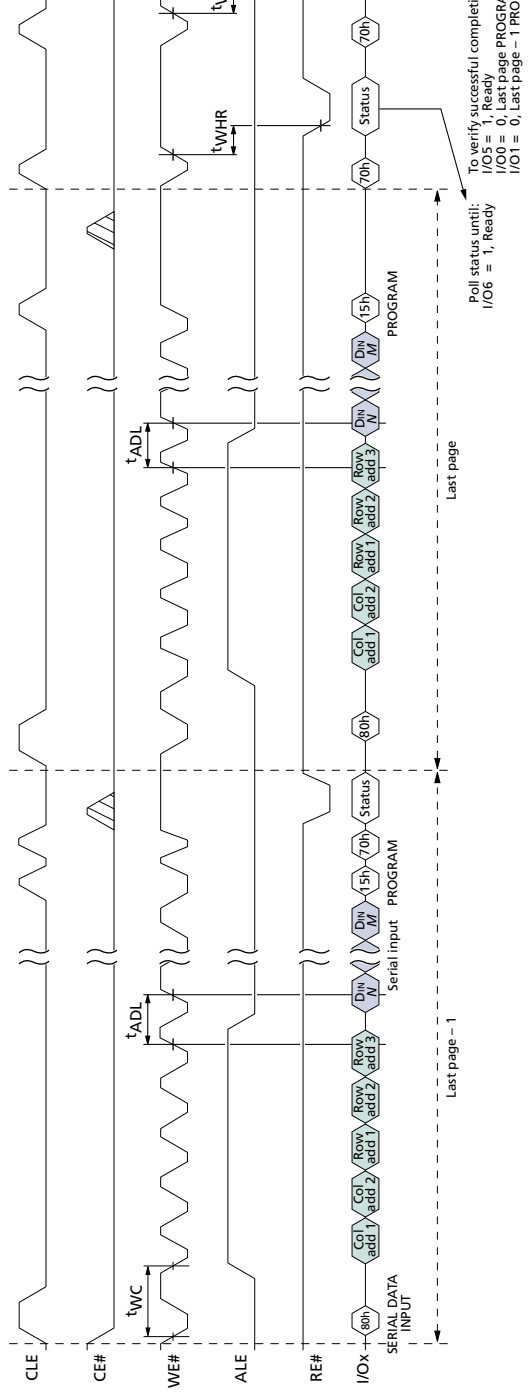

Figure 74: BLOCK ERASE Operation

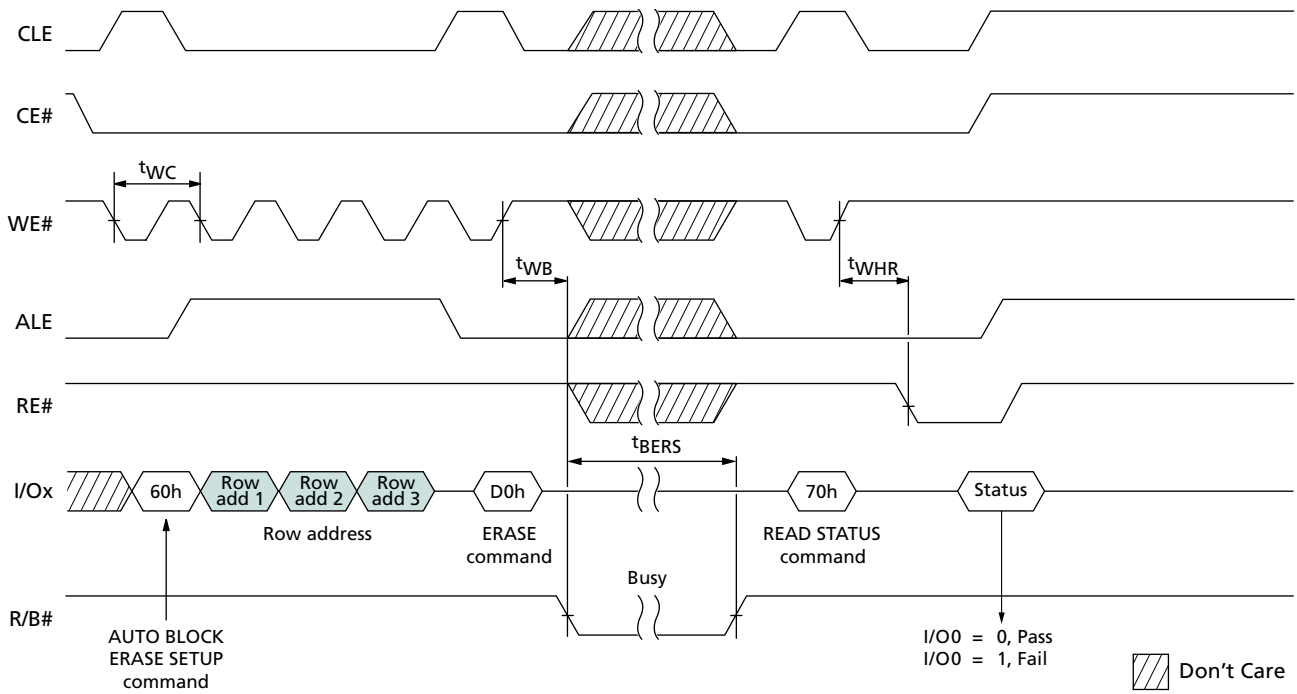
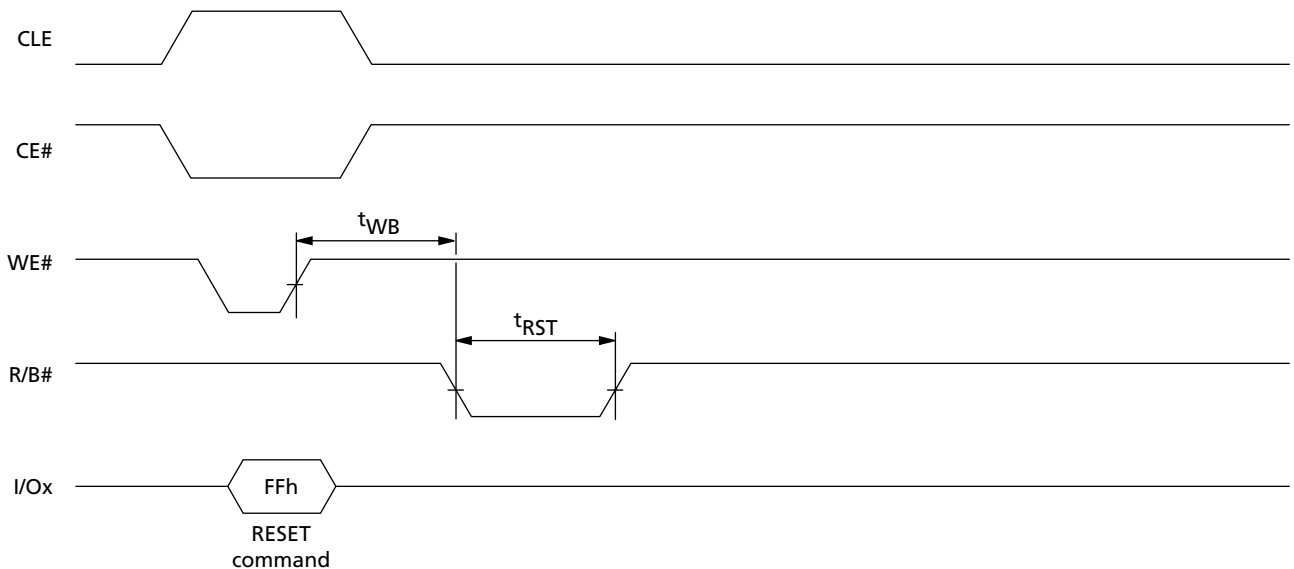
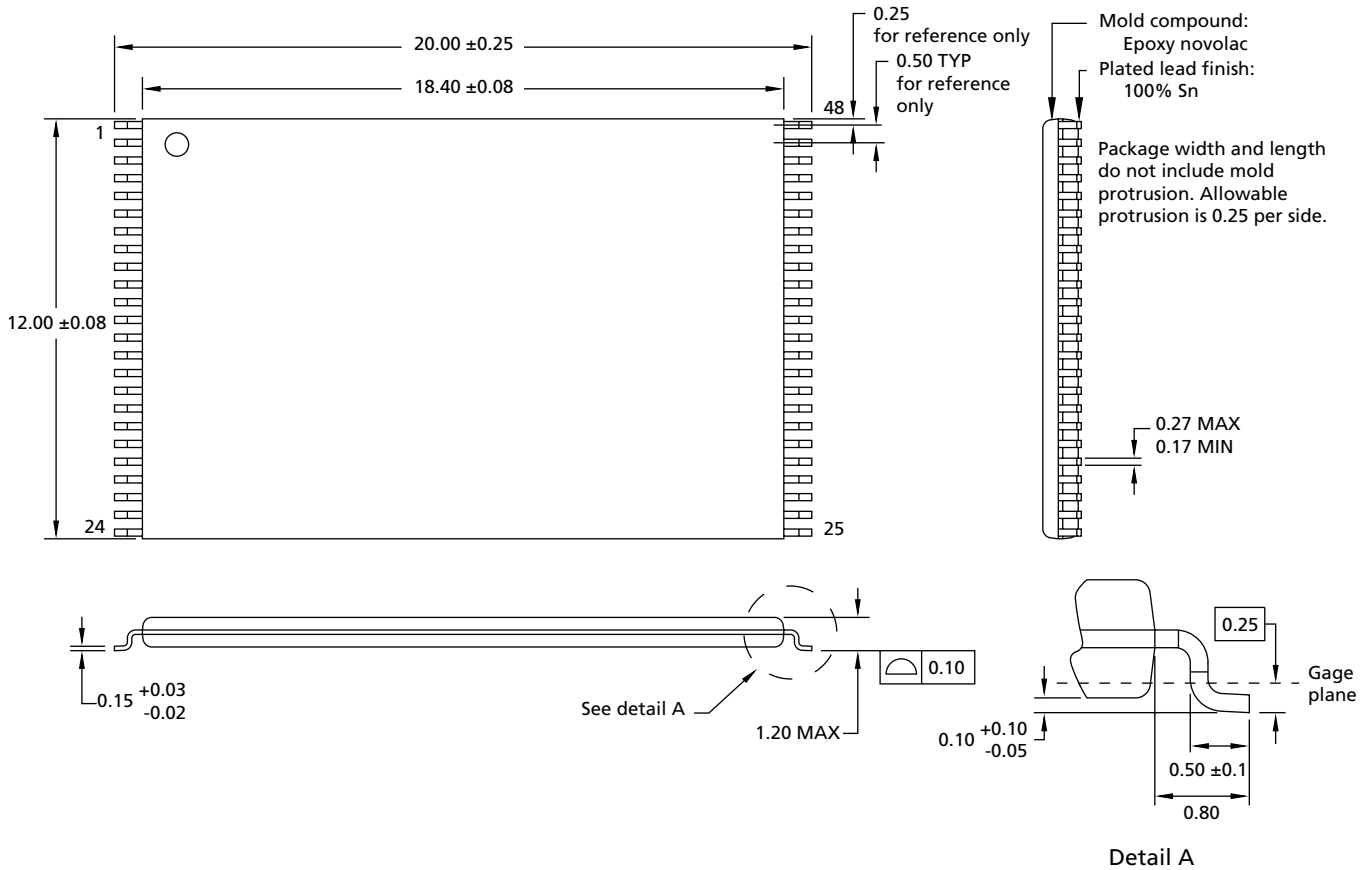

Figure 75: RESET Operation



Package Dimensions

Figure 76: 48-Pin TSOP Type 1 (WP Package Code)



Note: All dimensions are in millimeters.

Figure 77: 48-Pin TSOP OCPL Type 1 (WC Package Code)

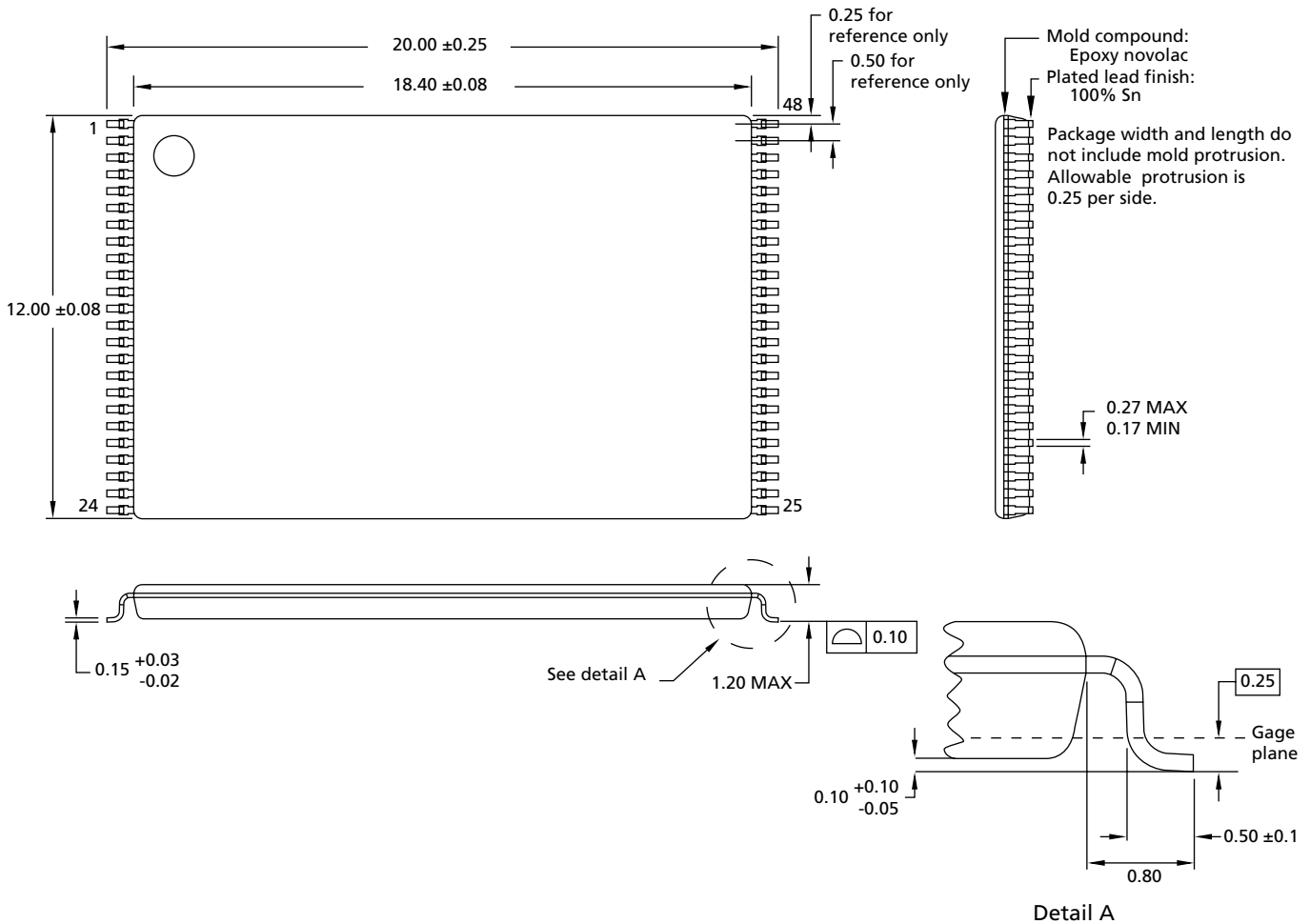

Note: All dimensions are in millimeters.



8000 S. Federal Way, P.O. Box 6, Boise, ID 83707-0006, Tel: 208-368-3900

prodmktg@micron.com www.micron.com Customer Comment Line: 800-932-4992

Micron, the M logo, and the Micron logo are trademarks of Micron Technology, Inc. All other trademarks are the property of their respective owners.

This data sheet contains minimum and maximum limits specified over the complete power supply and temperature range for production devices. Although considered final, these specifications are subject to change, as further product development and data characterization sometimes occur.

Revision History

Rev. B2/07

- Page 1: Added MT29F8G08BAA to title, 8Gb (dual-die stack 1 CE#), 8Gb (dual-die stack 2 CE#) to density options, 2 die, 1 CE#, 1 RB# to configuration options. Added extended temperature to options.
- Figure 2 on page 2: Added classification B: 2 die, 1 CE#, 1 RB#. Added extended temperature and note to contact factory.
- “General Description” on page 8: Added MT29F8G08BAA to first paragraph; revised fourth paragraph.
- Figure 3 on page 9: Modified note 1.
- Figure 5 on page 12: Revised block information.
- Figure 7 on page 14: Added new part number information to figure title and note 2.
- Table 4 on page 14: Changed part numbers in title.
- Former Figure 8 on page 17, “Time Constants” and Figure 9 on page 17, “Minimum Rp”: Converted to equation format.
- Table 8 on page 25: Added MT29F8G08BAA in bytes 1, 2, and 4, modified interleaved operations description, added note 3, changed part number in note 2.
- “Two-Plane Addressing” on page 35: Revised second bullet re BA18.
- “Error Management” on page 58: Modified second bullet.
- Table 12 on page 59: Added extended temperature.
- Tables 13 and 14 on page 61, Table 15 on page 62: Added MT29F8G08DAA.
- Table 19 on page 64: Changed ^tCBSY (MAX) and ^tPROG (MAX) to 600µs.

Rev. A8/06

- Initial release.

Looking for pricing, stock, or lifecycle information?

Click below to explore more details on WIN SOURCE:

 [View MT29F16G08DAAWP-ET:A TR on WIN SOURCE](#)

 [Micron Technology Inc. Information](#)

Optimize Your Supply Chain with WIN SOURCE Solutions

-  Global Sourcing Solution
-  Obsolete Management
-  Cost Control Management
-  Shortage Management
-  Alternative Solution
-  Excess Inventory Management