



**THE DATASHEET OF  
MSP430F5658IPZR**



# MSP430F665x, MSP430F645x, MSP430F565x, MSP430F535x Mixed-Signal Microcontrollers

## 1 Device Overview

### 1.1 Features

- Low Supply Voltage Range:  
3.6 V Down to 1.8 V
- Ultra-Low-Power Consumption
  - Active Mode (AM):  
All System Clocks Active:  
295  $\mu$ A/MHz at 8 MHz, 3.0 V, Flash Program Execution (Typical)
  - Standby Mode (LPM3):  
Watchdog With Crystal, and Supply Supervisor Operational, Full RAM Retention, Fast Wakeup:  
2.0  $\mu$ A at 2.2 V, 2.2  $\mu$ A at 3.0 V (Typical)
  - Shutdown, Real-Time Clock (RTC) Mode (LPM3.5):  
Shutdown Mode, Active RTC With Crystal:  
1.1  $\mu$ A at 3.0 V (Typical)
  - Shutdown Mode (LPM4.5):  
0.45  $\mu$ A at 3.0 V (Typical)
- Wake up From Standby Mode in 3  $\mu$ s (Typical)
- 16-Bit RISC Architecture, Extended Memory, up to 20-MHz System Clock
- Flexible Power-Management System
  - Fully Integrated LDO With Programmable Regulated Core Supply Voltage
  - Supply Voltage Supervision, Monitoring, and Brownout
- Unified Clock System
  - FLL Control Loop for Frequency Stabilization
  - Low-Power Low-Frequency Internal Clock Source (VLO)
  - Low-Frequency Trimmed Internal Reference Source (REFO)
  - 32-kHz Crystals (XT1)
  - High-Frequency Crystals up to 32 MHz (XT2)
- Four 16-Bit Timers With 3, 5, or 7 Capture/Compare Registers
- Three Universal Serial Communication Interfaces (USCIs)
  - USCI\_A0, USCI\_A1, and USCI\_A2 Each Support:
    - Enhanced UART With Automatic Baud-Rate Detection
    - IrDA Encoder and Decoder
    - Synchronous SPI
  - USCI\_B0, USCI\_B1, and USCI\_B2 Each Support:
    - I<sup>2</sup>C
    - Synchronous SPI
- Full-Speed Universal Serial Bus (USB)
  - Integrated USB-PHY
  - Integrated 3.3-V and 1.8-V USB Power System
  - Integrated USB-PLL
  - Eight Input and Eight Output Endpoints
- 12-Bit Analog-to-Digital Converter (ADC) With Internal Shared Reference, Sample-and-Hold, and Autoscan Feature
- Two 12-Bit Digital-to-Analog Converters (DACs) With Synchronization
- Voltage Comparator
- Integrated LCD Driver With Contrast Control for up to 160 Segments
- Hardware Multiplier Supports 32-Bit Operations
- Serial Onboard Programming, No External Programming Voltage Needed
- Six-Channel Internal DMA
- RTC Module With Supply Voltage Backup Switch
- [Device Comparison](#) Summarizes the Available Family Members

### 1.2 Applications

- Analog and Digital Sensor Systems
- Digital Motor Controls
- Remote Controls
- Thermostats
- Digital Timers
- Hand-Held Meters



### 1.3 Description

The TI MSP family of ultra-low-power microcontrollers consists of several devices that feature different sets of peripherals targeted for various applications. The architecture, combined with five low-power modes, is optimized to achieve extended battery life in portable measurement applications. The device features a powerful 16-bit RISC CPU, 16-bit registers, and constant generators that contribute to maximum code efficiency. The digitally controlled oscillator (DCO) allows the device to wake up from low-power modes to active mode in 3 μs (typical).

The MSP430F665x and MSP430F565x series are microcontroller configurations with four 16-bit timers, a high-performance 12-bit ADC, three USCI, a hardware multiplier, DMA, an RTC module with alarm capabilities, a comparator, USB 2.0, and up to 74 I/O pins.

The MSP430F645x and MSP430F535x series are microcontroller configurations with an integrated 3.3-V LDO, four 16-bit timers, a high-performance 12-bit ADC, three USCI, a hardware multiplier, DMA, an RTC module with alarm capabilities, a comparator, and up to 74 I/O pins.

For complete module descriptions, see the [MSP430F5xx and MSP430F6xx Family User's Guide](#).

#### Device Information<sup>(1)</sup>

PART NUMBER	PACKAGE	BODY SIZE <sup>(2)</sup>
MSP430F6659IZQW	MicroStar Junior™ BGA (113)	7 mm x 7 mm
MSP430F6659IPZ	LQFP (100)	14 mm x 14 mm

(1) For the most current device, package, and ordering information, see the *Package Option Addendum* in [Section 8](#), or see the TI website at [www.ti.com](#).

(2) The sizes shown here are approximations. For the package dimensions with tolerances, see the *Mechanical Data* in [Section 8](#).

### 1.4 Functional Block Diagrams

Figure 1-1 through Figure 1-4 show the functional block diagrams.

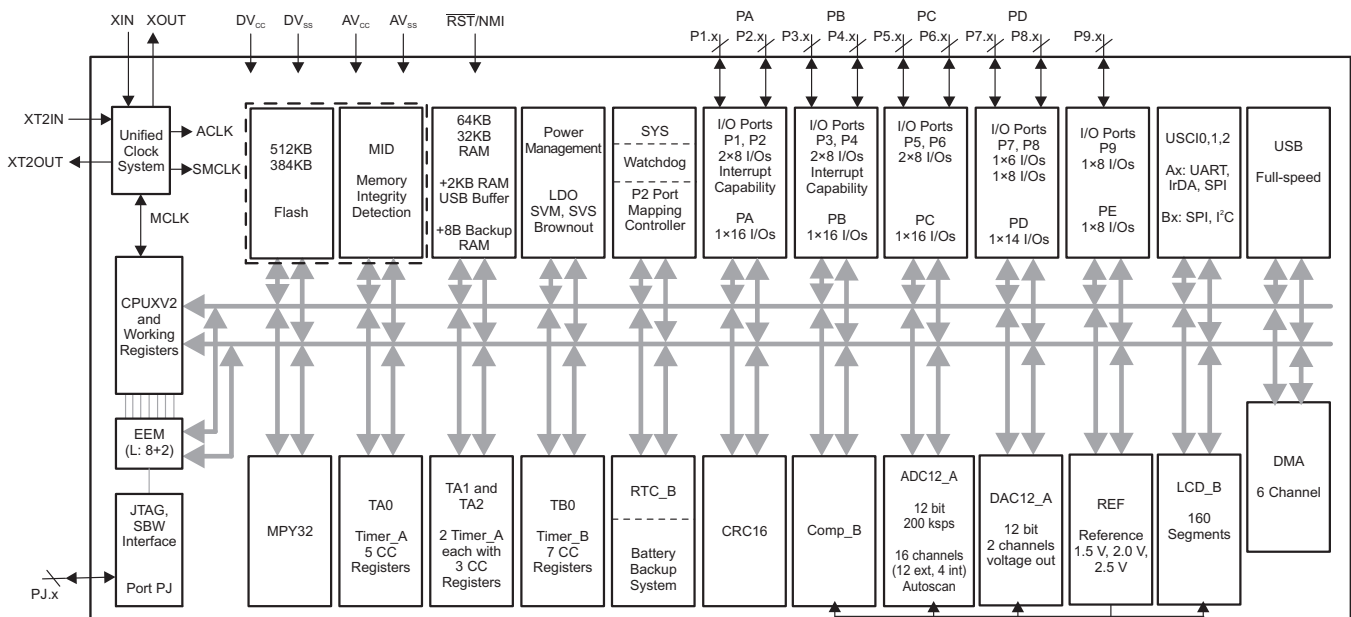

Copyright © 2016, Texas Instruments Incorporated

Figure 1-1. Functional Block Diagram – MSP430F6659, MSP430F6658

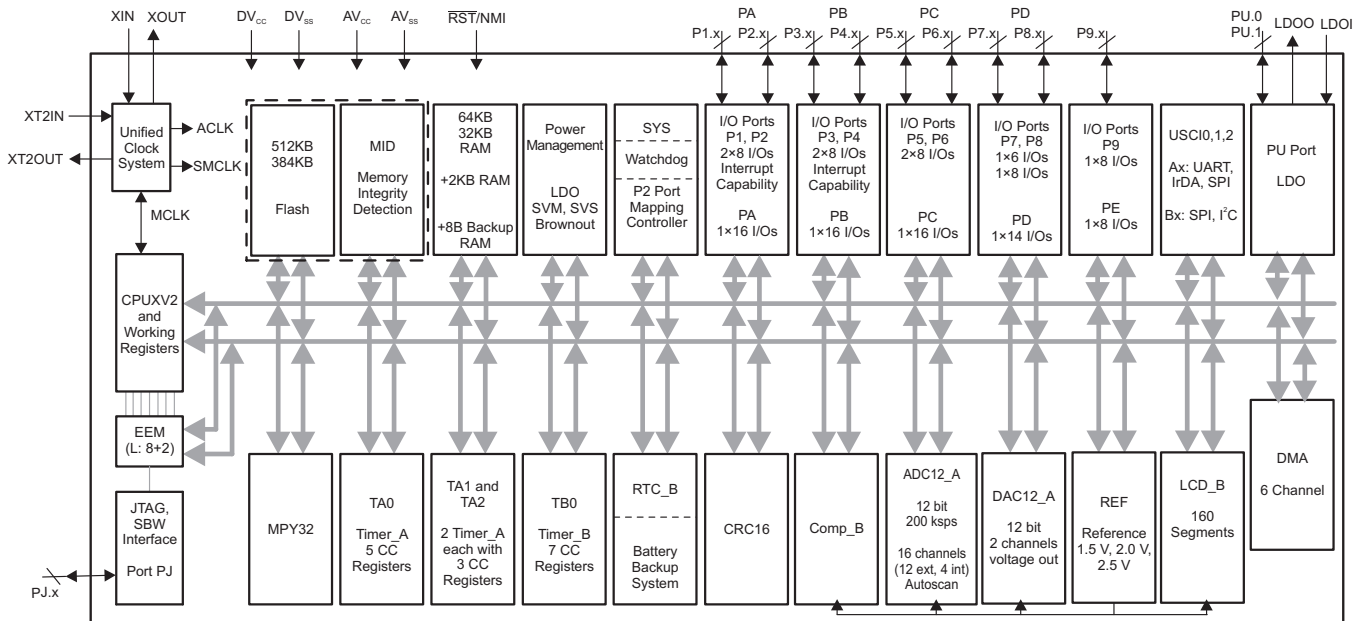

Copyright © 2016, Texas Instruments Incorporated

Figure 1-2. Functional Block Diagram – MSP430F6459, MSP430F6458

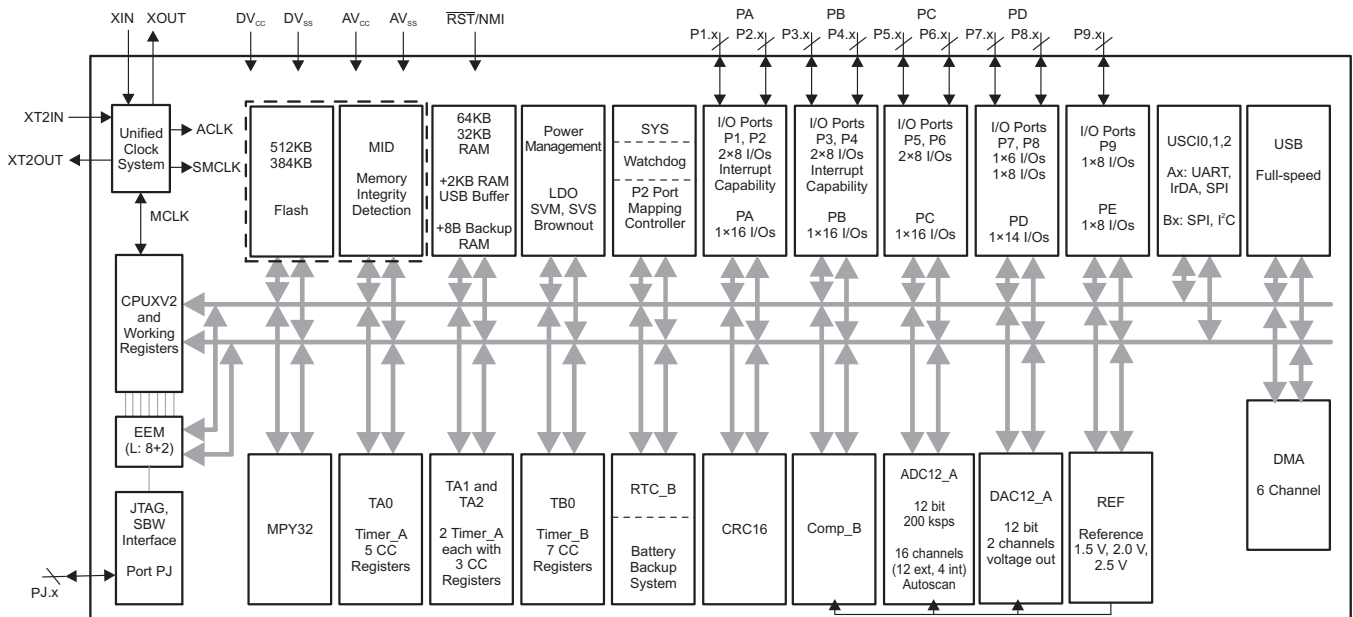

Copyright © 2016, Texas Instruments Incorporated

Figure 1-3. Functional Block Diagram – MSP430F5659, MSP430F5658

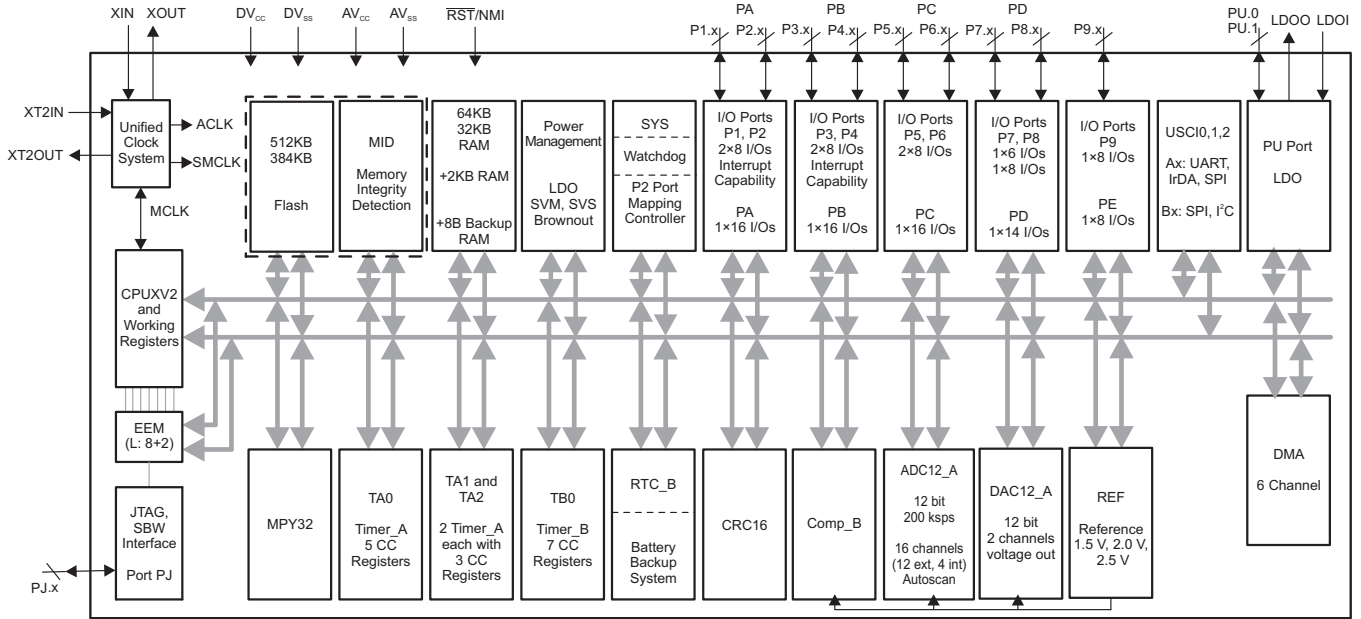

Copyright © 2016, Texas Instruments Incorporated

**Figure 1-4. Functional Block Diagram – MSP430F5359, MSP430F5358**

## Table of Contents

<b>1</b>	<b>Device Overview</b>	<b>1</b>	5.34	USCI (I <sup>2</sup> C Mode)	<b>42</b>
1.1	Features	1	5.35	LCD_B Operating Characteristics	<b>43</b>
1.2	Applications	1	5.36	LCD_B Electrical Characteristics	<b>44</b>
1.3	Description	2	5.37	12-Bit ADC, Power Supply and Input Range Conditions	<b>44</b>
1.4	Functional Block Diagrams	2	5.38	12-Bit ADC, Timing Parameters	<b>45</b>
<b>2</b>	<b>Revision History</b>	<b>6</b>	5.39	12-Bit ADC, Linearity Parameters Using an External Reference Voltage	<b>45</b>
<b>3</b>	<b>Device Comparison</b>	<b>7</b>	5.40	12-Bit ADC, Linearity Parameters Using AV <sub>CC</sub> as Reference Voltage	<b>46</b>
3.1	Related Products	8	5.41	12-Bit ADC, Linearity Parameters Using the Internal Reference Voltage	<b>46</b>
<b>4</b>	<b>Terminal Configuration and Functions</b>	<b>9</b>	5.42	12-Bit ADC, Temperature Sensor and Built-In V <sub>MID</sub>	<b>46</b>
4.1	Pin Diagrams	9	5.43	REF, External Reference	<b>47</b>
4.2	Signal Descriptions	14	5.44	REF, Built-In Reference	<b>48</b>
<b>5</b>	<b>Specifications</b>	<b>21</b>	5.45	12-Bit DAC, Supply Specifications	<b>49</b>
5.1	Absolute Maximum Ratings	21	5.46	12-Bit DAC, Linearity Specifications	<b>50</b>
5.2	ESD Ratings	21	5.47	12-Bit DAC, Output Specifications	<b>51</b>
5.3	Recommended Operating Conditions	21	5.48	12-Bit DAC, Reference Input Specifications	<b>52</b>
5.4	Active Mode Supply Current Into V <sub>CC</sub> Excluding External Current	23	5.49	12-Bit DAC, Dynamic Specifications	<b>52</b>
5.5	Low-Power Mode Supply Currents (Into V <sub>CC</sub> ) Excluding External Current	23	5.50	12-Bit DAC, Dynamic Specifications (Continued)	<b>53</b>
5.6	Low-Power Mode With LCD Supply Currents (Into V <sub>CC</sub> ) Excluding External Current	25	5.51	Comparator_B	<b>54</b>
5.7	Thermal Resistance Characteristics	25	5.52	Ports PU.0 and PU.1	<b>55</b>
5.8	Schmitt-Trigger Inputs – General-Purpose I/O	26	5.53	USB Output Ports DP and DM	<b>55</b>
5.9	Inputs – Ports P1, P2, P3, and P4	26	5.54	USB Input Ports DP and DM	<b>55</b>
5.10	Leakage Current – General-Purpose I/O	26	5.55	USB-PWR (USB Power System)	<b>55</b>
5.11	Outputs – General-Purpose I/O (Full Drive Strength)	26	5.56	USB-PLL (USB Phase Locked Loop)	<b>56</b>
5.12	Outputs – General-Purpose I/O (Reduced Drive Strength)	27	5.57	Flash Memory	<b>56</b>
5.13	Output Frequency – Ports P1, P2, and P3	27	5.58	JTAG and Spy-Bi-Wire Interface	<b>56</b>
5.14	Typical Characteristics – Outputs, Reduced Drive Strength (PxDS.y = 0)	28	<b>6</b>	<b>Detailed Description</b>	<b>57</b>
5.15	Typical Characteristics – Outputs, Full Drive Strength (PxDS.y = 1)	29	6.1	CPU ( <a href="#">Link to User's Guide</a> )	<b>57</b>
5.16	Crystal Oscillator, XT1, Low-Frequency Mode	30	6.2	Instruction Set	<b>58</b>
5.17	Crystal Oscillator, XT2	31	6.3	Operating Modes	<b>59</b>
5.18	Internal Very-Low-Power Low-Frequency Oscillator (VLO)	32	6.4	Interrupt Vector Addresses	<b>60</b>
5.19	Internal Reference, Low-Frequency Oscillator (REFO)	32	6.5	Memory Organization	<b>62</b>
5.20	DCO Frequency	33	6.6	Bootloader (BSL)	<b>63</b>
5.21	PMM, Brownout Reset (BOR)	34	6.7	JTAG Operation	<b>64</b>
5.22	PMM, Core Voltage	34	6.8	Flash Memory ( <a href="#">Link to User's Guide</a> )	<b>64</b>
5.23	PMM, SVS High Side	35	6.9	Memory Integrity Detection (MID) ( <a href="#">Link to User's Guide</a> )	<b>65</b>
5.24	PMM, SVM High Side	35	6.10	RAM ( <a href="#">Link to User's Guide</a> )	<b>65</b>
5.25	PMM, SVS Low Side	36	6.11	Backup RAM ( <a href="#">Link to User's Guide</a> )	<b>65</b>
5.26	PMM, SVM Low Side	36	6.12	Peripherals	<b>66</b>
5.27	Wake-up Times From Low-Power Modes	36	6.13	Input/Output Diagrams	<b>90</b>
5.28	Timer_A – Timers TA0, TA1, and TA2	37	6.14	Device Descriptors	<b>116</b>
5.29	Timer_B – Timer TB0	37	<b>7</b>	<b>Device and Documentation Support</b>	<b>117</b>
5.30	Battery Backup	37	7.1	Getting Started and Next Steps	<b>117</b>
5.31	USCI (UART Mode)	38	7.2	Device Nomenclature	<b>117</b>
5.32	USCI (SPI Master Mode)	38	7.3	Tools and Software	<b>119</b>
5.33	USCI (SPI Slave Mode)	40	7.4	Documentation Support	<b>121</b>
			7.5	Related Links	<b>122</b>
			7.6	Community Resources	<b>122</b>

7.7 Trademarks .....	<a href="#">122</a>	7.10 Glossary.....	<a href="#">123</a>
7.8 Electrostatic Discharge Caution .....	<a href="#">123</a>	<b>8 Mechanical, Packaging, and Orderable Information .....</b>	<b><a href="#">123</a></b>
7.9 Export Control Notice .....	<a href="#">123</a>		

## 2 Revision History

NOTE: Page numbers for previous revisions may differ from page numbers in the current version.

### Changes from October 21, 2013 to September 26, 2018

Page

• Format and organization changes throughout document, including addition of section numbering .....	<a href="#">1</a>
• Added <i>Device Information</i> table .....	<a href="#">2</a>
• Added <a href="#">Section 1.4</a> and moved all functional block diagrams to it.....	<a href="#">2</a>
• Added <a href="#">Section 3.1</a> , <i>Related Products</i> .....	<a href="#">8</a>
• Added "Port U is supplied the LDOO rail" to the description of PU.0 and PU.1 in <a href="#">Table 4-1</a> , <i>Signal Descriptions</i> ...	<a href="#">19</a>
• Added <a href="#">Section 5</a> and moved all electrical specifications to it .....	<a href="#">21</a>
• Added typical conditions statements at the beginning of <a href="#">Section 5</a> , <i>Specifications</i> .....	<a href="#">21</a>
• Added <a href="#">Section 5.2</a> , <i>ESD Ratings</i> .....	<a href="#">21</a>
• Moved <a href="#">Section 5.7</a> , <i>Thermal Resistance Characteristics</i> .....	<a href="#">25</a>
• Changed the TYP value of the $C_{L,eff}$ parameter with Test Conditions of "XTS = 0, XCAPx = 0" from 2 pF to 1 pF in <a href="#">Section 5.16</a> , <i>Crystal Oscillator, XT1, Low-Frequency Mode</i> .....	<a href="#">30</a>
• Changed the MIN value of the $V_{(DVCC\_BOR\_hys)}$ parameter from 60 mV to 50 mV in <a href="#">Section 5.21</a> , <i>PMM, Brownout Reset (BOR)</i> .....	<a href="#">34</a>
• Updated notes (1) and (2) and added note (3) in <a href="#">Section 5.27</a> , <i>Wake-up Times From Low-Power Modes and Reset</i> .....	<a href="#">36</a>
• Corrected typo in the description of the $V_{BAT3}$ parameter: changed " $V_{BAT3} \neq V_{BAT}/3$ " to " $V_{BAT3} \approx V_{BAT}/3$ " in <a href="#">Section 5.30</a> , <i>Battery Backup</i> .....	<a href="#">37</a>
• Removed ADC12DIV from the formula for the TYP value in the second row of the $t_{CONVERT}$ parameter in <a href="#">Section 5.38</a> , <i>12-Bit ADC, Timing Parameters</i> , because ADC12CLK is after division .....	<a href="#">45</a>
• Added the $TC_{SENSOR}$ parameter in <a href="#">Section 5.42</a> , <i>12-Bit ADC, Temperature Sensor and Built-In <math>V_{MID}</math></i> .....	<a href="#">46</a>
• Changed the note that starts "The temperature sensor offset ..." from "...offset can be as much as $\pm 20^{\circ}C$ " to "...offset can be significant" .....	<a href="#">46</a>
• Changed DAC12xDAT to DAC12_xDAT in $I_{L(DAC12)}$ Test Conditions in <a href="#">Section 5.47</a> , <i>12-Bit DAC, Output Specifications</i> .....	<a href="#">51</a>
• Removed note from " $R_{i(VREF+)}$ , $R_{i(VREF-)}$ " parameter in <a href="#">Section 5.48</a> , <i>12-Bit DAC, Reference Input Specifications</i> ...	<a href="#">52</a>
• Changed from $f_{DAC12\_0OUT}$ to $f_{DAC12\_1OUT}$ in the first row of the Test Conditions for the "Channel-to-channel crosstalk" parameter in <a href="#">Section 5.50</a> , <i>12-Bit DAC, Dynamic Specifications (Continued)</i> .....	<a href="#">53</a>
• Changed the value of DAC12_xDAT from 7F7h to F7Fh and changed the x-axis label from $f_{Toggle}$ to $1/f_{Toggle}$ in <a href="#">Figure 5-22</a> , <i>Crosstalk Test Conditions</i> .....	<a href="#">53</a>
• <a href="#">Section 5.51</a> , <i>Comparator_B</i> : Added second row for the $t_{EN\_CMP}$ parameter with Test Conditions of "CBPWRMD = 10" and MAX value of 100 $\mu s$ ; Removed "CBPWRMD = 10" option in first row of Test Conditions .....	<a href="#">54</a>
• Added note on $R_{PUR}$ in <a href="#">Section 5.55</a> , <i>USB-PWR (USB Power System)</i> .....	<a href="#">55</a>
• Removed RTC_B from LPM4.5 wake-up options in <a href="#">Section 6.3</a> , <i>Operating Modes</i> .....	<a href="#">59</a>
• Throughout document, changed "bootstrap loader" to "bootloader" .....	<a href="#">63</a>
• Added the paragraph that begins "Using the MSP430 RTC_B Module With Battery Backup Supply describes how to..." .....	<a href="#">68</a>
• Corrected spelling of NMIFG in <a href="#">Table 6-12</a> , <i>System Module Interrupt Vector Registers</i> .....	<a href="#">69</a>
• Corrected register names (added "USB" prefix as required) in <a href="#">Table 6-53</a> , <i>USB Control Registers</i> .....	<a href="#">89</a>
• Added P7SEL.2 and XT2BYPASS inputs with AND and OR gates in <a href="#">Figure 6-10</a> , <i>Port P7 (P7.3) Diagram</i> .....	<a href="#">104</a>
• Changed P7SEL.3 column from X to 0 for "P7.3 (I/O)" rows in <a href="#">Table 6-63</a> , <i>Port P7 (P7.2 and P7.3) Pin Functions</i> .....	<a href="#">104</a>
• Updated <a href="#">Table 6-67</a> , <i>Port PU.0, PU.1 Functions</i> .....	<a href="#">112</a>
• Added <a href="#">Section 6.13.14</a> , <i>Port PU.0, PU.1 Ports (F645x, F535x)</i> .....	<a href="#">113</a>
• Added <a href="#">Section 7</a> , <i>Device and Documentation Support</i> , and moved <i>Development Tools Support, Device and Development Tool Nomenclature, Trademarks, and Electrostatic Discharge Caution</i> sections to it .....	<a href="#">117</a>
• Replaced former section <i>Development Tools Support</i> with <a href="#">Section 7.3</a> , <i>Tools and Software</i> .....	<a href="#">119</a>
• Added <a href="#">Section 8</a> , <i>Mechanical, Packaging, and Orderable Information</i> .....	<a href="#">123</a>

### 3 Device Comparison

Table 3-1 summarizes the available family members.

Table 3-1. Device Comparison<sup>(1)(2)</sup>

DEVICE	FLASH (KB)	SRAM (KB) <sup>(3)</sup>	Timer_A <sup>(4)</sup>	Timer_B <sup>(5)</sup>	USCI		ADC12_A (Ch)	DAC12_A (Ch)	Comp_B (Ch)	I/O	USB	LCD	PACKAGE
					CHANNEL A: UART, IrDA, SPI	CHANNEL B: SPI, I <sup>2</sup> C							
MSP430F6659	512	64 + 2	5, 3, 3	7	3	3	12 ext, 4 int	2	12	74	Yes	Yes	100 PZ, 113 ZQW
MSP430F6658	384	32 + 2	5, 3, 3	7	3	3	12 ext, 4 int	2	12	74	Yes	Yes	100 PZ, 113 ZQW
MSP430F6459	512	66	5, 3, 3	7	3	3	12 ext, 4 int	2	12	74	No	Yes	100 PZ, 113 ZQW
MSP430F6458	384	34	5, 3, 3	7	3	3	12 ext, 4 int	2	12	74	No	Yes	100 PZ, 113 ZQW
MSP430F5659	512	64 + 2	5, 3, 3	7	3	3	12 ext, 4 int	2	12	74	Yes	No	100 PZ, 113 ZQW
MSP430F5658	384	32 + 2	5, 3, 3	7	3	3	12 ext, 4 int	2	12	74	Yes	No	100 PZ, 113 ZQW
MSP430F5359	512	66	5, 3, 3	7	3	3	12 ext, 4 int	2	12	74	No	No	100 PZ, 113 ZQW
MSP430F5358	384	34	5, 3, 3	7	3	3	12 ext, 4 int	2	12	74	No	No	100 PZ, 113 ZQW

- (1) For the most current device, package, and ordering information, see the *Package Option Addendum* in Section 8, or see the TI website at [www.ti.com](http://www.ti.com).
- (2) Package drawings, standard packing quantities, thermal data, symbolization, and PCB design guidelines are available at [www.ti.com/packaging](http://www.ti.com/packaging).
- (3) The additional 2KB of USB SRAM that is listed can be used as general-purpose SRAM when USB is not in use.
- (4) Each number in the sequence represents an instantiation of Timer\_A with its associated number of capture compare registers and PWM output generators available. For example, a number sequence of 3, 5 would represent two instantiations of Timer\_A, the first instantiation having 3 and the second instantiation having 5 capture compare registers and PWM output generators, respectively.
- (5) Each number in the sequence represents an instantiation of Timer\_B with its associated number of capture compare registers and PWM output generators available. For example, a number sequence of 3, 5 would represent two instantiations of Timer\_B, the first instantiation having 3 and the second instantiation having 5 capture compare registers and PWM output generators, respectively.

### 3.1 Related Products

For information about other devices in this family of products or related products, see the following links.

**Products for TI Microcontrollers** TI's low-power and high-performance MCUs, with wired and wireless connectivity options, are optimized for a broad range of applications.

**Products for MSP430 Ultra-Low-Power Microcontrollers** One platform. One ecosystem. Endless possibilities. Enabling the connected world with innovations in ultra-low-power microcontrollers with advanced peripherals for precise sensing and measurement.

**Companion Products for MSP430F6659** Review products that are frequently purchased or used with this product.

**TI Reference Designs** Find reference designs that leverage the best in TI technology to solve your system-level challenges.

## 4 Terminal Configuration and Functions

### 4.1 Pin Diagrams

Figure 4-1 shows the pinout of the 100-pin PZ package for the MSP430F6659 and MSP430F6658 devices.

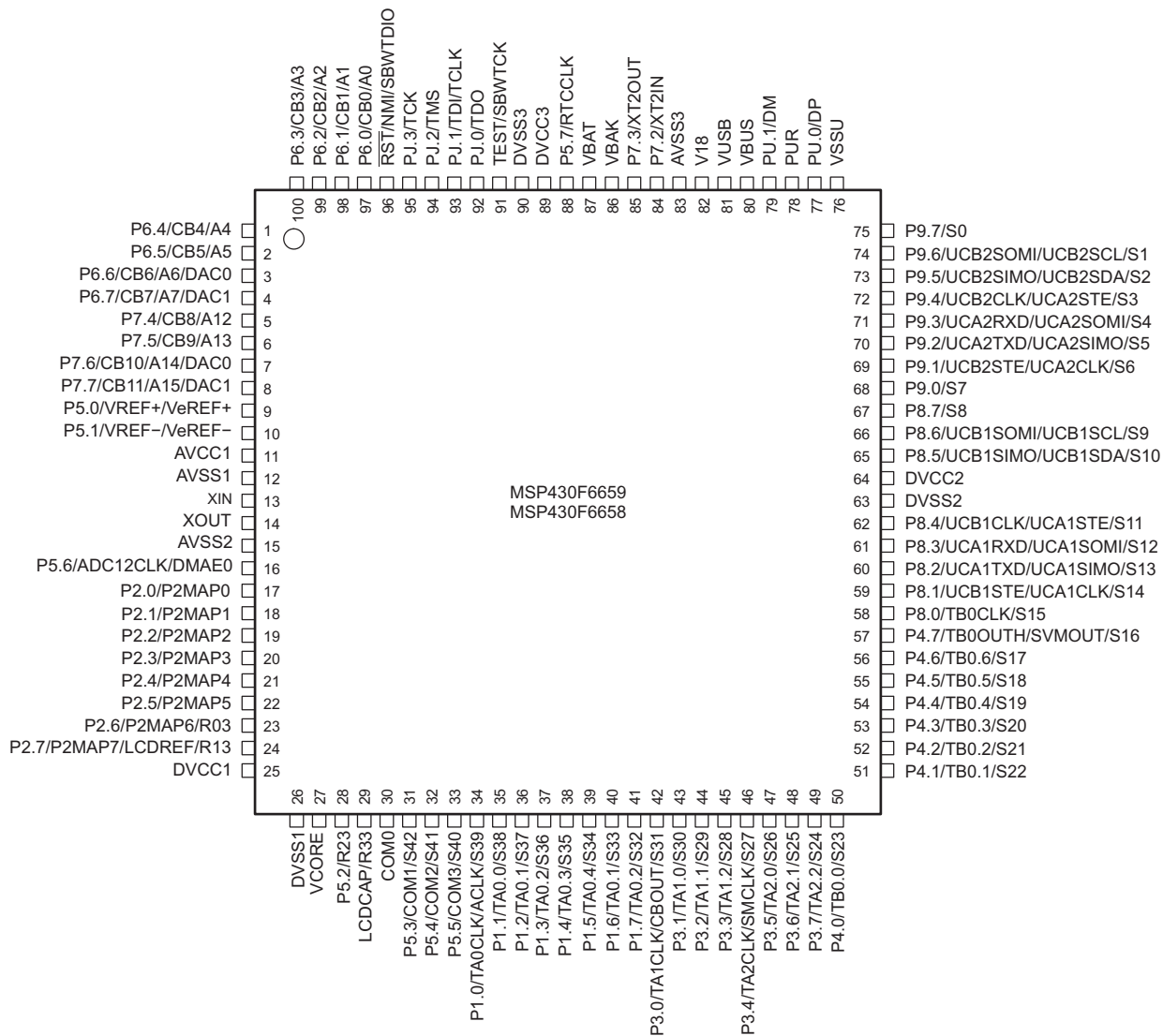
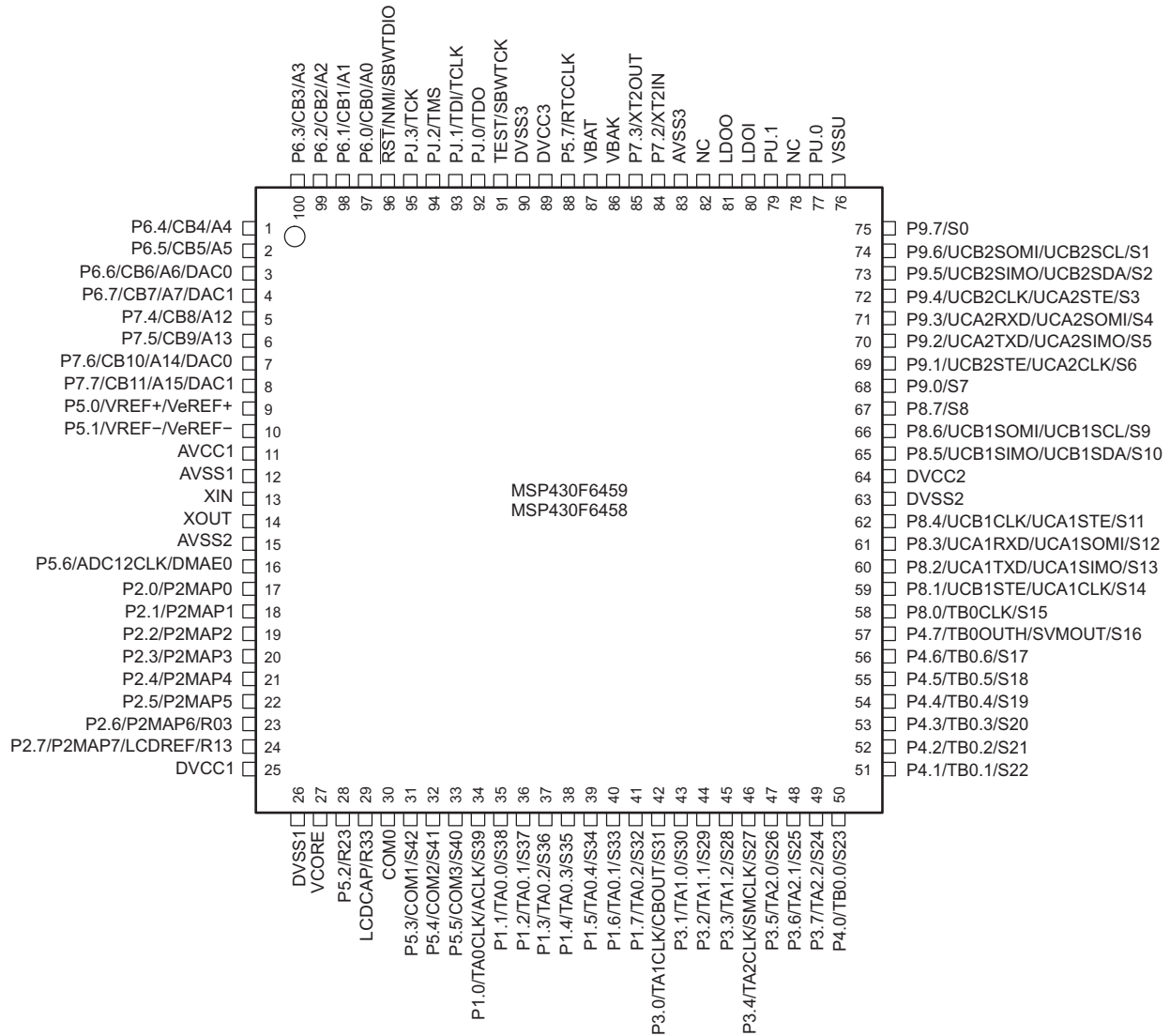

Figure 4-1. 100-Pin PZ Package (Top View) – MSP430F6659IPZ, MSP430F6658IPZ

Figure 4-1 shows the pinout of the 100-pin PZ package for the MSP430F6459 and MSP430F6458 devices.



**Figure 4-2. 100-Pin PZ Package (Top View) – MSP430F6459IPZ, MSP430F6458IPZ**

Figure 4-3 shows the pinout of the 100-pin PZ package for the MSP430F5659 and MSP430F5658 devices.

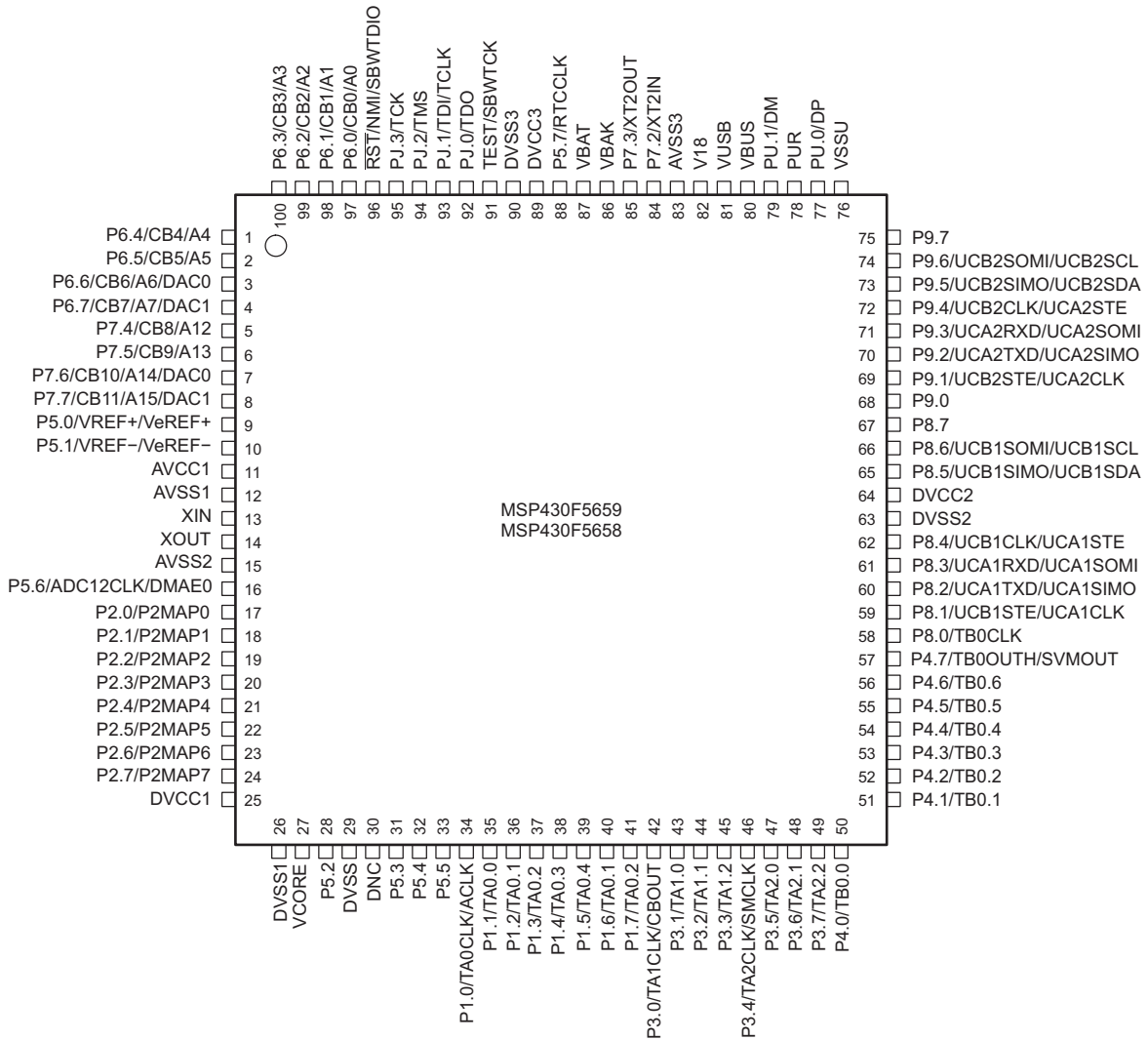

**Figure 4-3. 100-Pin PZ Package (Top View) – MSP430F5659IPZ, MSP430F5658IPZ**

Figure 4-4 shows the pinout of the 100-pin PZ package for the MSP430F5359 and MSP430F5358 devices.

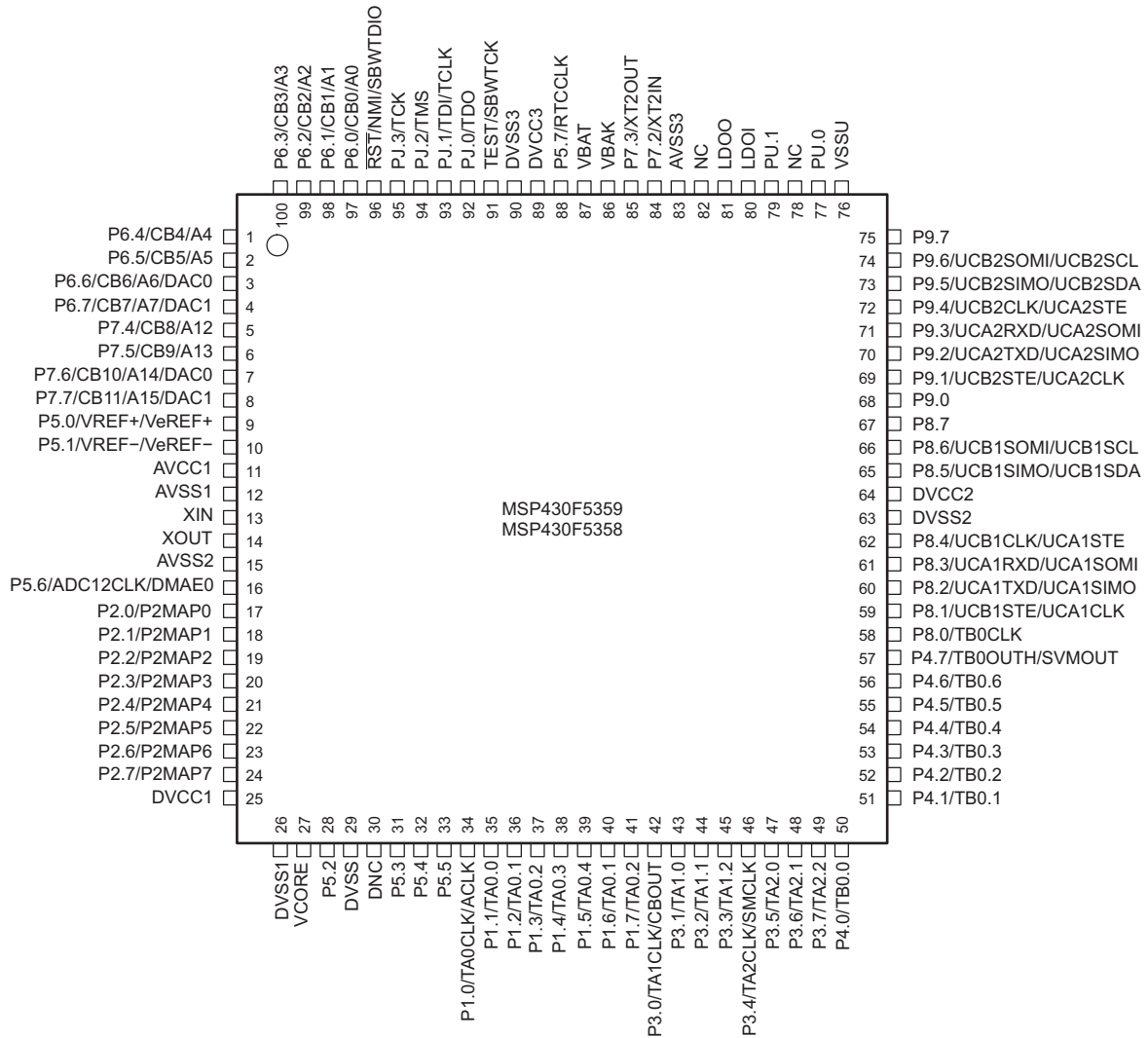
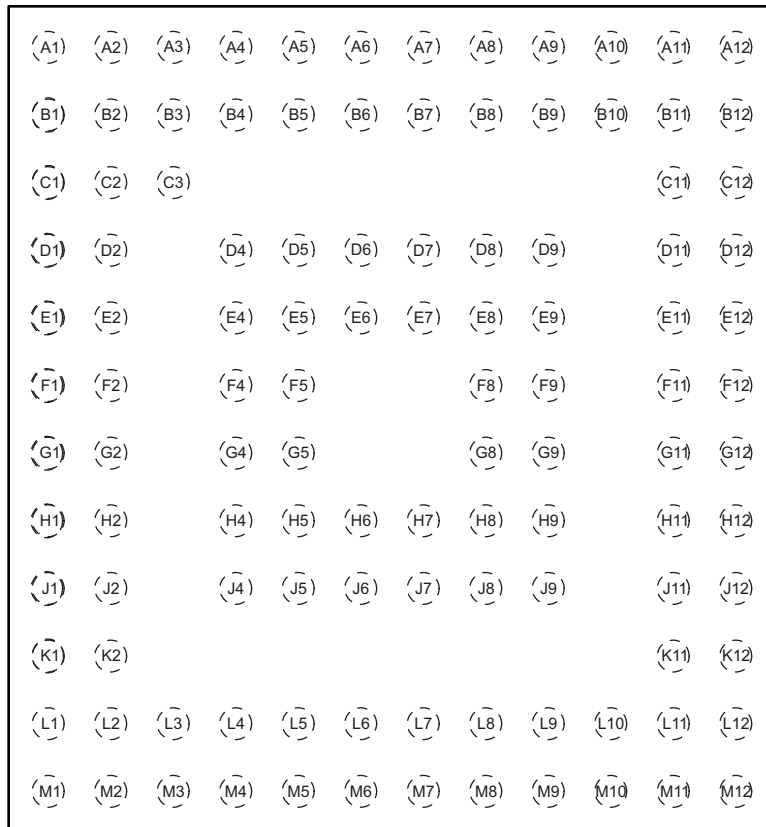

Figure 4-4. 100-Pin PZ Package (Top View) – MSP430F5359IPZ, MSP430F5358IPZ

Figure 4-4 shows the pinout of the 113-pin ZQW package. See Section 4.2 for the pin assignments.



**Figure 4-5. 113-Pin ZQW Package (Top View) – MSP430F6659IZQW, MSP430F6658IZQW, MSP430F6459IZQW, MSP430F6458IZQW, MSP430F5659IZQW, MSP430F5658IZQW, MSP430F5359IZQW, MSP430F5358IZQW**

## 4.2 Signal Descriptions

Table 4-1 describes the signals for all device variants and package options.

**Table 4-1. Signal Descriptions**

TERMINAL			I/O <sup>(1)</sup>	DESCRIPTION
NAME	NO.			
	PZ	ZQW		
P6.4/CB4/A4	1	A1	I/O	General-purpose digital I/O Comparator_B input CB4 Analog input A4 for ADC
P6.5/CB5/A5	2	B2	I/O	General-purpose digital I/O Comparator_B input CB5 Analog input A5 for ADC
P6.6/CB6/A6/DAC0	3	B1	I/O	General-purpose digital I/O Comparator_B input CB6 Analog input A6 for ADC DAC12.0 output
P6.7/CB7/A7/DAC1	4	C2	I/O	General-purpose digital I/O Comparator_B input CB7 Analog input A7 for ADC DAC12.1 output
P7.4/CB8/A12	5	C1	I/O	General-purpose digital I/O Comparator_B input CB8 Analog input A12 –ADC
P7.5/CB9/A13	6	C3	I/O	General-purpose digital I/O Comparator_B input CB9 Analog input A13 for ADC
P7.6/CB10/A14/DAC0	7	D2	I/O	General-purpose digital I/O Comparator_B input CB10 Analog input A14 for ADC DAC12.0 output
P7.7/CB11/A15/DAC1	8	D1	I/O	General-purpose digital I/O Comparator_B input CB11 Analog input A15 for ADC DAC12.1 output
P5.0/VREF+/VeREF+	9	D4	I/O	General-purpose digital I/O Output of reference voltage to the ADC Input for an external reference voltage to the ADC
P5.1/VREF-/VeREF-	10	E4	I/O	General-purpose digital I/O Negative terminal for the ADC's reference voltage for both sources, the internal reference voltage, or an external applied reference voltage
AVCC1	11	E1, E2		Analog power supply
AVSS1	12	F2		Analog ground supply
XIN	13	F1	I	Input terminal for crystal oscillator XT1
XOUT	14	G1	O	Output terminal of crystal oscillator XT1

(1) I = input, O = output, N/A = not available on this package offering

**Table 4-1. Signal Descriptions (continued)**

TERMINAL			I/O <sup>(1)</sup>	DESCRIPTION
NAME	NO.			
	PZ	ZQW		
AVSS2	15	G2		Analog ground supply
P5.6/ADC12CLK/DMAE0	16	H1	I/O	General-purpose digital I/O Conversion clock output ADC DMA external trigger input
P2.0/P2MAP0	17	G4	I/O	General-purpose digital I/O with port interrupt and mappable secondary function Default mapping: USCI_B0 SPI slave transmit enable; USCI_A0 clock input/output
P2.1/P2MAP1	18	H2	I/O	General-purpose digital I/O with port interrupt and mappable secondary function Default mapping: USCI_B0 SPI slave in, master out; USCI_B0 I2C data
P2.2/P2MAP2	19	J1	I/O	General-purpose digital I/O with port interrupt and mappable secondary function Default mapping: USCI_B0 SPI slave out, master in; USCI_B0 I2C clock
P2.3/P2MAP3	20	H4	I/O	General-purpose digital I/O with port interrupt and mappable secondary function Default mapping: USCI_B0 clock input/output; USCI_A0 SPI slave transmit enable
P2.4/P2MAP4	21	J2	I/O	General-purpose digital I/O with port interrupt and mappable secondary function Default mapping: USCI_A0 UART transmit data; USCI_A0 SPI slave in, master out
P2.5/P2MAP5	22	K1	I/O	General-purpose digital I/O with port interrupt and mappable secondary function Default mapping: USCI_A0 UART receive data; USCI_A0 slave out, master in
P2.6/P2MAP6/R03	23	K2	I/O	General-purpose digital I/O with port interrupt and mappable secondary function Default mapping: no secondary function Input/output port of lowest analog LCD voltage (V5) (not available on F5659, F5658, F5359, F5358 devices)
P2.7/P2MAP7/LCDREF/R13	24	L2	I/O	General-purpose digital I/O with port interrupt and mappable secondary function Default mapping: no secondary function External reference voltage input for regulated LCD voltage (not available on F5659, F5658, F5359, F5358 devices) Input/output port of third most positive analog LCD voltage (V3 or V4) (not available on F5659, F5658, F5359, F5358 devices)
DVCC1	25	L1		Digital power supply
DVSS1	26	M1		Digital ground supply
VCORE <sup>(2)</sup>	27	M2		Regulated core power supply (internal use only, no external current loading)
P5.2/R23	28	L3	I/O	General-purpose digital I/O Input/output port of second most positive analog LCD voltage (V2) (not available on F5659, F5658, F5359, F5358 devices)
LDCAP/R33	29	M3	I/O	LCD capacitor connection (not available on F5659, F5658, F5359, F5358 devices) Input/output port of most positive analog LCD voltage (V1) (not available on F5659, F5658, F5359, F5358 devices)
DVSS	29	M3		Digital ground supply (not available on F6659, F6658, F6459, and F6458 devices)
COM0	30	J4	O	LCD common output COM0 for LCD backplane (not available on F5659, F5658, F5359, F5358 devices)
DNC	30	J4		Do not connect. TI strongly recommends leaving this terminal open (not available on F6659, F6658, F6459, and F6458 devices)
P5.3/COM1/S42	31	L4	I/O	General-purpose digital I/O LCD common output COM1 for LCD backplane (not available on F5659, F5658, F5359, F5358 devices) LCD segment output S42 (not available on F5659, F5658, F5359, F5358 devices)

(2) VCORE is for internal use only. No external current loading is possible. VCORE should only be connected to the recommended capacitor value, C<sub>VCORE</sub>.

**Table 4-1. Signal Descriptions (continued)**

TERMINAL			I/O <sup>(1)</sup>	DESCRIPTION
NAME	NO.			
	PZ	ZQW		
P5.4/COM2/S41	32	M4	I/O	General-purpose digital I/O LCD common output COM2 for LCD backplane (not available on F5659, F5658, F5359, F5358 devices) LCD segment output S41 (not available on F5659, F5658, F5359, F5358 devices)
P5.5/COM3/S40	33	J5	I/O	General-purpose digital I/O LCD common output COM3 for LCD backplane (not available on F5659, F5658, F5359, F5358 devices) LCD segment output S40 (not available on F5659, F5658, F5359, F5358 devices)
P1.0/TA0CLK/ACLK/S39	34	L5	I/O	General-purpose digital I/O with port interrupt Timer TA0 clock signal TACLK input ACLK output (divided by 1, 2, 4, 8, 16, or 32) LCD segment output S39 (not available on F5659, F5658, F5359, F5358 devices)
P1.1/TA0.0/S38	35	M5	I/O	General-purpose digital I/O with port interrupt Timer TA0 CCR0 capture: CCI0A input, compare: Out0 output BSL transmit output LCD segment output S38 (not available on F5659, F5658, F5359, F5358 devices)
P1.2/TA0.1/S37	36	J6	I/O	General-purpose digital I/O with port interrupt Timer TA0 CCR1 capture: CCI1A input, compare: Out1 output BSL receive input LCD segment output S37 (not available on F5659, F5658, F5359, F5358 devices)
P1.3/TA0.2/S36	37	H6	I/O	General-purpose digital I/O with port interrupt Timer TA0 CCR2 capture: CCI2A input, compare: Out2 output LCD segment output S36 (not available on F5659, F5658, F5359, F5358 devices)
P1.4/TA0.3/S35	38	M6	I/O	General-purpose digital I/O with port interrupt Timer TA0 CCR3 capture: CCI3A input compare: Out3 output LCD segment output S35 (not available on F5659, F5658, F5359, F5358 devices)
P1.5/TA0.4/S34	39	L6	I/O	General-purpose digital I/O with port interrupt Timer TA0 CCR4 capture: CCI4A input, compare: Out4 output LCD segment output S34 (not available on F5659, F5658, F5359, F5358 devices)
P1.6/TA0.1/S33	40	J7	I/O	General-purpose digital I/O with port interrupt Timer TA0 CCR1 capture: CCI1B input, compare: Out1 output LCD segment output S33 (not available on F5659, F5658, F5359, F5358 devices)
P1.7/TA0.2/S32	41	M7	I/O	General-purpose digital I/O with port interrupt Timer TA0 CCR2 capture: CCI2B input, compare: Out2 output LCD segment output S32 (not available on F5659, F5658, F5359, F5358 devices)
P3.0/TA1CLK/CBOUT/S31	42	L7	I/O	General-purpose digital I/O with port interrupt Timer TA1 clock input Comparator_B output LCD segment output S31 (not available on F5659, F5658, F5359, F5358 devices)
P3.1/TA1.0/S30	43	H7	I/O	General-purpose digital I/O with port interrupt Timer TA1 capture CCR0: CCI0A/CCI0B input, compare: Out0 output LCD segment output S30 (not available on F5659, F5658, F5359, F5358 devices)

**Table 4-1. Signal Descriptions (continued)**

TERMINAL			I/O <sup>(1)</sup>	DESCRIPTION
NAME	NO.			
	PZ	ZQW		
P3.2/TA1.1/S29	44	M8	I/O	General-purpose digital I/O with port interrupt Timer TA1 capture CCR1: CCI1A/CCI1B input, compare: Out1 output LCD segment output S29 (not available on F5659, F5658, F5359, F5358 devices)
P3.3/TA1.2/S28	45	L8	I/O	General-purpose digital I/O with port interrupt Timer TA1 capture CCR2: CCI2A/CCI2B input, compare: Out2 output LCD segment output S28 (not available on F5659, F5658, F5359, F5358 devices)
P3.4/TA2CLK/SMCLK/S27	46	J8	I/O	General-purpose digital I/O with port interrupt Timer TA2 clock input SMCLK output LCD segment output S27 (not available on F5659, F5658, F5359, F5358 devices)
P3.5/TA2.0/S26	47	M9	I/O	General-purpose digital I/O with port interrupt Timer TA2 capture CCR0: CCI0A/CCI0B input, compare: Out0 output LCD segment output S26 (not available on F5659, F5658, F5359, F5358 devices)
P3.6/TA2.1/S25	48	L9	I/O	General-purpose digital I/O with port interrupt Timer TA2 capture CCR1: CCI1A/CCI1B input, compare: Out1 output LCD segment output S25 (not available on F5659, F5658, F5359, F5358 devices)
P3.7/TA2.2/S24	49	M10	I/O	General-purpose digital I/O with port interrupt Timer TA2 capture CCR2: CCI2A/CCI2B input, compare: Out2 output LCD segment output S24 (not available on F5659, F5658, F5359, F5358 devices)
P4.0/TB0.0/S23	50	J9	I/O	General-purpose digital I/O with port interrupt Timer TB0 capture CCR0: CCI0A/CCI0B input, compare: Out0 output LCD segment output S23 (not available on F5659, F5658, F5359, F5358 devices)
P4.1/TB0.1/S22	51	M11	I/O	General-purpose digital I/O with port interrupt Timer TB0 capture CCR1: CCI1A/CCI1B input, compare: Out1 output LCD segment output S22 (not available on F5659, F5658, F5359, F5358 devices)
P4.2/TB0.2/S21	52	L10	I/O	General-purpose digital I/O with port interrupt Timer TB0 capture CCR2: CCI2A/CCI2B input, compare: Out2 output LCD segment output S21 (not available on F5659, F5658, F5359, F5358 devices)
P4.3/TB0.3/S20	53	M12	I/O	General-purpose digital I/O with port interrupt Timer TB0 capture CCR3: CCI3A/CCI3B input, compare: Out3 output LCD segment output S20 (not available on F5659, F5658, F5359, F5358 devices)
P4.4/TB0.4/S19	54	L12	I/O	General-purpose digital I/O with port interrupt Timer TB0 capture CCR4: CCI4A/CCI4B input, compare: Out4 output LCD segment output S19 (not available on F5659, F5658, F5359, F5358 devices)
P4.5/TB0.5/S18	55	L11	I/O	General-purpose digital I/O with port interrupt Timer TB0 capture CCR5: CCI5A/CCI5B input, compare: Out5 output LCD segment output S18 (not available on F5659, F5658, F5359, F5358 devices)
P4.6/TB0.6/S17	56	K11	I/O	General-purpose digital I/O with port interrupt Timer TB0 capture CCR6: CCI6A/CCI6B input, compare: Out6 output LCD segment output S17 (not available on F5659, F5658, F5359, F5358 devices)

**Table 4-1. Signal Descriptions (continued)**

TERMINAL			I/O <sup>(1)</sup>	DESCRIPTION
NAME	NO.			
	PZ	ZQW		
P4.7/TB0OUTH/SVMOUT/S16	57	K12	I/O	General-purpose digital I/O with port interrupt Timer TB0: Switch all PWM outputs high impedance SVM output LCD segment output S16 (not available on F5659, F5658, F5359, F5358 devices)
P8.0/TB0CLK/S15	58	J11	I/O	General-purpose digital I/O Timer TB0 clock input LCD segment output S15 (not available on F5659, F5658, F5359, F5358 devices)
P8.1/UCB1STE/UCA1CLK/S14	59	J12	I/O	General-purpose digital I/O USCI_B1 SPI slave transmit enable USCI_A1 clock input/output LCD segment output S14 (not available on F5659, F5658, F5359, F5358 devices)
P8.2/UCA1TXD/UCA1SIMO/S13	60	H11	I/O	General-purpose digital I/O USCI_A1 UART transmit data USCI_A1 SPI slave in, master out LCD segment output S13 (not available on F5659, F5658, F5359, F5358 devices)
P8.3/UCA1RXD/UCA1SOMI/S12	61	H12	I/O	General-purpose digital I/O USCI_A1 UART receive data USCI_A1 SPI slave out, master in LCD segment output S12 (not available on F5659, F5658, F5359, F5358 devices)
P8.4/UCB1CLK/UCA1STE/S11	62	G11	I/O	General-purpose digital I/O USCI_B1 clock input/output USCI_A1 SPI slave transmit enable LCD segment output S11 (not available on F5659, F5658, F5359, F5358 devices)
DVSS2	63	G12		Digital ground supply
DVCC2	64	F12		Digital power supply
P8.5/UCB1SIMO/UCB1SDA/S10	65	F11	I/O	General-purpose digital I/O USCI_B1 SPI slave in, master out USCI_B1 I2C data LCD segment output S10 (not available on F5659, F5658, F5359, F5358 devices)
P8.6/UCB1SOMI/UCB1SCL/S9	66	G9	I/O	General-purpose digital I/O USCI_B1 SPI slave out, master in USCI_B1 I2C clock LCD segment output S9 (not available on F5659, F5658, F5359, F5358 devices)
P8.7/S8	67	E12	I/O	General-purpose digital I/O LCD segment output S8 (not available on F5659, F5658, F5359, F5358 devices)
P9.0/S7	68	E11	I/O	General-purpose digital I/O LCD segment output S7 (not available on F5659, F5658, F5359, F5358 devices)
P9.1/UCB2STE/UCA2CLK/S6	69	F9	I/O	General-purpose digital I/O USCI_B2 SPI slave transmit enable USCI_A2 clock input/output LCD segment output S6 (not available on F5659, F5658, F5359, F5358 devices)

**Table 4-1. Signal Descriptions (continued)**

TERMINAL			I/O <sup>(1)</sup>	DESCRIPTION
NAME	NO.			
	PZ	ZQW		
P9.2/UCA2TXD/UCA2SIMO/S5	70	D12	I/O	General-purpose digital I/O USCI_A2 UART transmit data USCI_A2 SPI slave in, master out LCD segment output S5 (not available on F5659, F5658, F5359, F5358 devices)
P9.3/UCA2RXD/UCA2SOMI/S4	71	D11	I/O	General-purpose digital I/O USCI_A2 UART receive data USCI_A2 SPI slave out, master in LCD segment output S4 (not available on F5659, F5658, F5359, F5358 devices)
P9.4/UCB2CLK/UCA2STE/S3	72	E9	I/O	General-purpose digital I/O USCI_B2 clock input/output USCI_A2 SPI slave transmit enable LCD segment output S3 (not available on F5659, F5658, F5359, F5358 devices)
P9.5/UCB2SIMO/UCB2SDA/S2	73	C12	I/O	General-purpose digital I/O USCI_B2 SPI slave in, master out USCI_B2 I2C data LCD segment output S2 (not available on F5659, F5658, F5359, F5358 devices)
P9.6/UCB2SOMI/UCB2SCL/S1	74	C11	I/O	General-purpose digital I/O USCI_B2 SPI slave out, master in USCI_B2 I2C clock LCD segment output S1 (not available on F5659, F5658, F5359, F5358 devices)
P9.7/S0	75	D9	I/O	General-purpose digital I/O LCD segment output S0 (not available on F5659, F5658, F5359, F5358 devices)
VSSU	76	B11, B12		USB PHY or PU ground supply
PU.0/DP	77	A12	I/O	General-purpose digital I/O – controlled by USB or PU control register (Port U is supplied the LDOO rail) USB data terminal DP (not available on F6459, F6458, F5359, F5358 devices)
PUR	78	B10	I/O	USB pullup resistor pin (open drain) (not available on F6459, F6458, F5359, F5358 devices)
NC	78	B10		Not connected (not available on F6659, F6658, F5659, F5658 devices)
PU.1/DM	79	A11	I/O	General-purpose digital I/O – controlled by USB or PU control register (Port U is supplied the LDOO rail) USB data terminal DM (not available on F6459, F6458, F5359, F5358 devices)
VBUS	80	A10		USB LDO input (connect to USB power source) (not available on F6459, F6458, F5359, F5358 devices)
LDOI	80	A10		LDO input (not available on F6659, F6658, F5659, F5658 devices)
VUSB	81	A9		USB LDO output (not available on F6459, F6458, F5359, F5358 devices)
LDOO	81	A9		LDO output (not available on F6659, F6658, F5659, F5658 devices)
V18	82	B9		USB regulated power (internal use only, no external current loading) (not available on F6459, F6458, F5359, F5358 devices)
NC	82	B9		Not connected (not available on F6659, F6658, F5659, F5658 devices)
AVSS3	83	A8		Analog ground supply
P7.2/XT2IN	84	B8	I/O	General-purpose digital I/O Input terminal for crystal oscillator XT2

**Table 4-1. Signal Descriptions (continued)**

TERMINAL			I/O <sup>(1)</sup>	DESCRIPTION
NAME	NO.			
	PZ	ZQW		
P7.3/XT2OUT	85	B7	I/O	General-purpose digital I/O Output terminal of crystal oscillator XT2
VBAK	86	A7		Capacitor for backup subsystem. Do not load this pin externally. For capacitor values, see C <sub>BAK</sub> in <a href="#">Section 5.3</a> .
VBAT	87	D8		Backup supply voltage. If backup voltage is not supplied, connect to DVCC externally.
P5.7/RTCCLK	88	D7	I/O	General-purpose digital I/O RTCCLK output
DVCC3	89	A6		Digital power supply
DVSS3	90	A5		Digital ground supply
TEST/SBWTCK	91	B6	I	Test mode pin – select digital I/O on JTAG pins Spy-Bi-Wire input clock
PJ.0/TDO	92	B5	I/O	General-purpose digital I/O Test data output port
PJ.1/TDI/TCLK	93	A4	I/O	General-purpose digital I/O Test data input or test clock input
PJ.2/TMS	94	E7	I/O	General-purpose digital I/O Test mode select
PJ.3/TCK	95	D6	I/O	General-purpose digital I/O Test clock
$\overline{\text{RST}}/\text{NMI}/\text{SBWTDIO}$	96	A3	I/O	Reset input active low <sup>(3)</sup> Nonmaskable interrupt input Spy-Bi-Wire data input/output
P6.0/CB0/A0	97	B4	I/O	General-purpose digital I/O Comparator_B input CB0 Analog input A0 for ADC
P6.1/CB1/A1	98	B3	I/O	General-purpose digital I/O Comparator_B input CB1 Analog input A1 for ADC
P6.2/CB2/A2	99	A2	I/O	General-purpose digital I/O Comparator_B input CB2 Analog input A2 for ADC
P6.3/CB3/A3	100	D5	I/O	General-purpose digital I/O Comparator_B input CB3 Analog input A3 for ADC
Reserved	N/A	E5, E6, E8, F4, F5, F8, G5, G8, H5, H8, H9		Reserved BGA package balls. TI recommends connecting to ground (DVSS, AVSS).

(3) When this pin is configured as reset, the internal pullup resistor is enabled by default.

## 5 Specifications

All graphs in this section are for typical conditions, unless otherwise noted.

Typical (TYP) values are specified at  $V_{CC} = 3.3\text{ V}$  and  $T_A = 25^\circ\text{C}$ , unless otherwise noted.

### 5.1 Absolute Maximum Ratings

over operating free-air temperature range (unless otherwise noted)<sup>(1)</sup>

	MIN	MAX	UNIT
Voltage applied at $V_{CC}$ to $V_{SS}$	-0.3	4.1	V
Voltage applied to any pin (excluding V <sub>CORE</sub> , V <sub>BUS</sub> , V18) <sup>(2)</sup>	-0.3	$V_{CC} + 0.3$	V
Diode current at any device pin		±2	mA
Storage temperature, $T_{stg}$ <sup>(3)</sup>	-55	150	°C
Maximum junction temperature, $T_J$		95	°C

- (1) Stresses beyond those listed under *Absolute Maximum Ratings* may cause permanent damage to the device. These are stress ratings only, and functional operation of the device at these or any other conditions beyond those indicated under *Recommended Operating Conditions* is not implied. Exposure to absolute-maximum-rated conditions for extended periods may affect device reliability.
- (2) All voltages referenced to  $V_{SS}$ . V<sub>CORE</sub> is for internal device use only. No external DC loading or voltage should be applied.
- (3) Higher temperature may be applied during board soldering according to the current JEDEC J-STD-020 specification with peak reflow temperatures not higher than classified on the device label on the shipping boxes or reels.

### 5.2 ESD Ratings

		VALUE	UNIT
$V_{(ESD)}$ Electrostatic discharge	Human-body model (HBM), per ANSI/ESDA/JEDEC JS-001 <sup>(1)</sup>	±1000	V
	Charged-device model (CDM), per JEDEC specification JESD22-C101 <sup>(2)</sup>	±250	

- (1) JEDEC document JEP155 states that 500-V HBM allows safe manufacturing with a standard ESD control process. Pins listed as ±1000 V may actually have higher performance.
- (2) JEDEC document JEP157 states that 250-V CDM allows safe manufacturing with a standard ESD control process. Pins listed as ±250 V may actually have higher performance.

### 5.3 Recommended Operating Conditions

		MIN	NOM	MAX	UNIT
$V_{CC}$	Supply voltage during program execution and flash programming ( $AVCC1 = DVCC1 = DVCC2 = DVCC3 = DV_{CC} = V_{CC}$ ) <sup>(1)(2)</sup>	PMMCOREVx = 0	1.8	3.6	V
		PMMCOREVx = 0, 1	2.0	3.6	
		PMMCOREVx = 0, 1, 2	2.2	3.6	
		PMMCOREVx = 0, 1, 2, 3	2.4	3.6	
$V_{CC,USB}$	Supply voltage during USB operation, USB PLL disabled, USB_EN = 1, UPLLEN = 0	PMMCOREVx = 0	1.8	3.6	V
		PMMCOREVx = 0, 1	2.0	3.6	
		PMMCOREVx = 0, 1, 2	2.2	3.6	
		PMMCOREVx = 0, 1, 2, 3	2.4	3.6	
	Supply voltage during USB operation, USB PLL enabled <sup>(3)</sup> , USB_EN = 1, UPLLEN = 1	PMMCOREVx = 2	2.2	3.6	
		PMMCOREVx = 2, 3	2.4	3.6	
$V_{SS}$	Supply voltage ( $AVSS1 = AVSS2 = AVSS3 = DVSS1 = DVSS2 = DVSS3 = V_{SS}$ )		0		V
$V_{BAT,RTC}$	Backup-supply voltage with RTC operational	$T_A = 0^\circ\text{C}$ to $85^\circ\text{C}$	1.55	3.6	V
		$T_A = -40^\circ\text{C}$ to $85^\circ\text{C}$	1.70	3.6	
$V_{BAT,MEM}$	Backup-supply voltage with backup memory retained.	$T_A = -40^\circ\text{C}$ to $85^\circ\text{C}$	1.20	3.6	V
$T_A$	Operating free-air temperature	I version	-40	85	°C
$T_J$	Operating junction temperature	I version	-40	85	°C
$C_{BAK}$	Capacitance at pin VBAK	1	4.7	10	nF

- (1) TI recommends powering AVCC and DVCC from the same source. A maximum difference of 0.3 V between AVCC and DVCC can be tolerated during power up and operation.
- (2) The minimum supply voltage is defined by the supervisor SVS levels when it is enabled. See the [Section 5.23](#) threshold parameters for the exact values and further details.
- (3) USB operation with USB PLL enabled requires PMMCOREVx ≥ 2 for proper operation.

**Recommended Operating Conditions (continued)**

		MIN	NOM	MAX	UNIT	
C <sub>VCORE</sub>	Capacitor at V <sub>CORE</sub> <sup>(4)</sup>		470		nF	
C <sub>DVCC</sub> / C <sub>VCORE</sub>	Capacitor ratio of DVCC to V <sub>CORE</sub>	10				
f <sub>SYSTEM</sub>	Processor frequency (maximum MCLK frequency) <sup>(5)(6)</sup> (see <a href="#">Figure 5-1</a> )	PMMCOREV <sub>x</sub> = 0, 1.8 V ≤ V <sub>CC</sub> ≤ 3.6 V (default condition)		0	8.0	MHz
		PMMCOREV <sub>x</sub> = 1, 2 V ≤ V <sub>CC</sub> ≤ 3.6 V		0	12.0	
		PMMCOREV <sub>x</sub> = 2, 2.2 V ≤ V <sub>CC</sub> ≤ 3.6 V		0	16.0	
		PMMCOREV <sub>x</sub> = 3, 2.4 V ≤ V <sub>CC</sub> ≤ 3.6 V		0	20.0	
f <sub>SYSTEM_USB</sub>	Minimum processor frequency for USB operation	1.5			MHz	
USB_wait	Wait state cycles during USB operation		16		cycles	

- (4) A capacitor tolerance of ±20% or better is required.
- (5) The MSP430 CPU is clocked directly with MCLK. Both the high and low phase of MCLK must not exceed the pulse duration of the specified maximum frequency.
- (6) Modules may have a different maximum input clock specification. See the specification of the respective module in this data sheet.

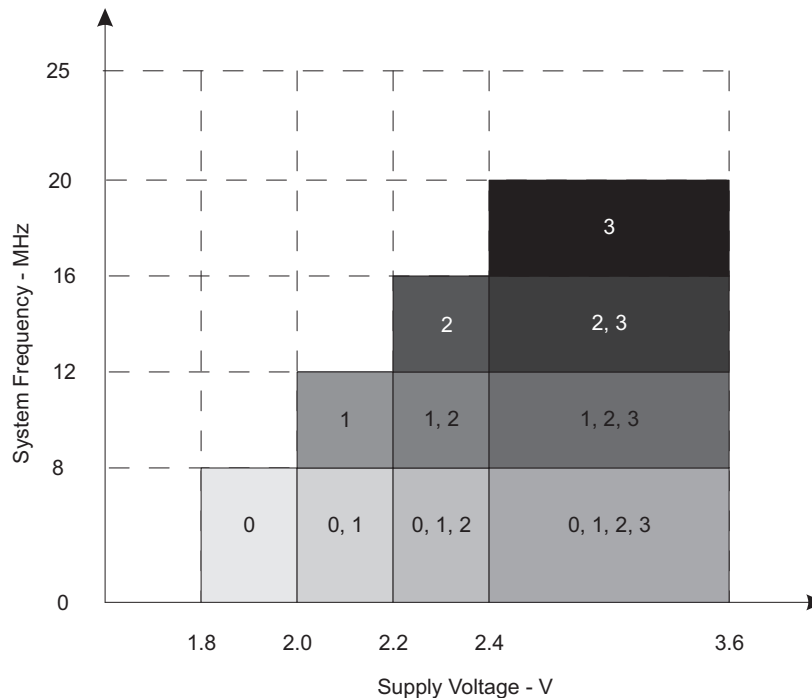

NOTE: The numbers within the fields denote the supported PMMCOREV<sub>x</sub> settings.

**Figure 5-1. Frequency vs Supply Voltage**

## 5.4 Active Mode Supply Current Into $V_{CC}$ Excluding External Current

over recommended operating free-air temperature (unless otherwise noted)<sup>(1) (2) (3)</sup>

PARAMETER	EXECUTION MEMORY	$V_{CC}$	PMMCOREVx	FREQUENCY ( $f_{DCO} = f_{MCLK} = f_{SMCLK}$ )								UNIT
				1 MHz		8 MHz		12 MHz		20 MHz		
				TYP	MAX	TYP	MAX	TYP	MAX	TYP	MAX	
$I_{AM, Flash}$	Flash	3 V	0	0.36	0.45	2.4	2.7					mA
			1	0.41		2.7		4.0	4.4			
			2	0.46		2.9		4.3				
			3	0.51		3.1		4.5		7.4		
$I_{AM, RAM}$	RAM	3 V	0	0.18	0.23	1.0	1.3					mA
			1	0.20		1.2		1.7	1.9			
			2	0.22		1.3		2.0				
			3	0.23		1.4		2.2		3.6		

(1) All inputs are tied to 0 V or to  $V_{CC}$ . Outputs do not source or sink any current.

(2) The currents are characterized with a Micro Crystal MS1V-T1K crystal with a load capacitance of 12.5 pF. The internal and external load capacitance are chosen to closely match the required 12.5 pF.

(3) Characterized with program executing typical data processing. USB disabled ( $VUSBEN = 0$ ,  $SLDOEN = 0$ ).

 $f_{ACLK} = 32786$  Hz,  $f_{DCO} = f_{MCLK} = f_{SMCLK}$  at specified frequency.

 $XTS = CPUOFF = SCG0 = SCG1 = OSCOFF = SMCLKOFF = 0$ .

## 5.5 Low-Power Mode Supply Currents (Into $V_{CC}$ ) Excluding External Current

over recommended ranges of supply voltage and operating free-air temperature (unless otherwise noted)<sup>(1) (2)</sup>

PARAMETER	$V_{CC}$	PMMCOREVx	-40°C		25°C		60°C		85°C		UNIT
			TYP	MAX	TYP	MAX	TYP	MAX	TYP	MAX	
$I_{LPM0, 1MHz}$ Low-power mode 0 <sup>(3) (4)</sup>	2.2 V	0	69		73	95	79		85	125	$\mu A$
	3 V	3	79		83	120	87		96	155	
$I_{LPM2}$ Low-power mode 2 <sup>(5) (4)</sup>	2.2 V	0	6.1		6.7	9.0	8.0		13	32	$\mu A$
	3 V	3	6.5		7.1	9.5	8.5		14	34	
$I_{LPM3, XT1LF}$ Low-power mode 3, crystal mode <sup>(6) (4)</sup>	2.2 V	0	1.5		2.0	3.3	3.3		8.2	27	$\mu A$
		1	1.7		2.2		3.6		8.7		
		2	1.9		2.4		3.8		8.9		
	3 V	0	1.8		2.2	3.5	3.6		8.6	28	
		1	1.9		2.4		3.8		9.0		
		2	2.1		2.6		4.0		9.1		
		3	2.1		2.6	4.2	4.0		9.1	29	

(1) All inputs are tied to 0 V or to  $V_{CC}$ . Outputs do not source or sink any current.

(2) The currents are characterized with a Micro Crystal CC4V-T1A SMD crystal with a load capacitance of 9 pF. The internal and external load capacitance are chosen to closely match the required 9 pF.

(3) Current for watchdog timer clocked by SMCLK included.  $ACLK$  = low frequency crystal operation ( $XTS = 0$ ,  $XT1DRIVEx = 0$ ).  $CPUOFF = 1$ ,  $SCG0 = 0$ ,  $SCG1 = 0$ ,  $OSCOFF = 0$  (LPM0),  $f_{ACLK} = 32768$  Hz,  $f_{MCLK} = 0$  MHz,  $f_{SMCLK} = f_{DCO} = 1$  MHz USB disabled ( $VUSBEN = 0$ ,  $SLDOEN = 0$ ).

(4) Current for brownout included. Low-side supervisor and monitors disabled ( $SVSL$ ,  $SVM_L$ ). High-side supervisor and monitor disabled ( $SVSH$ ,  $SVM_H$ ). RAM retention enabled.

(5) Current for watchdog timer clocked by  $ACLK$  and RTC clocked by LFXT1 (32768 Hz) included.  $ACLK$  = low frequency crystal operation ( $XTS = 0$ ,  $XT1DRIVEx = 0$ ).

 $CPUOFF = 1$ ,  $SCG0 = 0$ ,  $SCG1 = 1$ ,  $OSCOFF = 0$  (LPM2),  $f_{ACLK} = 32768$  Hz,  $f_{MCLK} = 0$  MHz,  $f_{SMCLK} = f_{DCO} = 0$  MHz, DCO setting = 1-MHz operation, DCO bias generator enabled. USB disabled ( $VUSBEN = 0$ ,  $SLDOEN = 0$ )

(6) Current for watchdog timer clocked by  $ACLK$  and RTC clocked by LFXT1 (32768 Hz) included.  $ACLK$  = low frequency crystal operation ( $XTS = 0$ ,  $XT1DRIVEx = 0$ ).

 $CPUOFF = 1$ ,  $SCG0 = 1$ ,  $SCG1 = 1$ ,  $OSCOFF = 0$  (LPM3),  $f_{ACLK} = 32768$  Hz,  $f_{MCLK} = f_{SMCLK} = f_{DCO} = 0$  MHz USB disabled ( $VUSBEN = 0$ ,  $SLDOEN = 0$ )

## Low-Power Mode Supply Currents (Into $V_{CC}$ ) Excluding External Current (*continued*)

over recommended ranges of supply voltage and operating free-air temperature (unless otherwise noted)<sup>(1) (2)</sup>

PARAMETER	$V_{CC}$	PMMCOREVx	-40°C		25°C		60°C		85°C		UNIT
			TYP	MAX	TYP	MAX	TYP	MAX	TYP	MAX	
$I_{LPM3,VLO, WDT}$ Low-power mode 3, VLO mode, Watchdog enabled <sup>(7) (4)</sup>	3 V	0	1.0		1.3	2.7	2.7		7.4	26	$\mu A$
			1.1		1.5		2.8		7.7		
			1.1		1.6		2.9		7.8		
			1.1	3.2	2.9		7.8	30			
$I_{LPM4}$ Low-power mode 4 <sup>(8) (4)</sup>	3 V	0	0.9		1.3	2.5	2.5		6.8	26	$\mu A$
			1.0		1.3		2.6		7.0		
			1.0		1.4		2.7		7.2		
			1.0	3.1	2.7		7.2	27			
$I_{LPM3.5,RTC, VCC}$ Low-power mode 3.5 (LPM3.5) current with active RTC into primary supply pin DV <sub>CC</sub> <sup>(9)</sup>	3 V				0.5			0.75	1.8	$\mu A$	
$I_{LPM3.5,RTC, VBAT}$ Low-power mode 3.5 (LPM3.5) current with active RTC into backup supply pin VBAT <sup>(10)</sup>	3 V				0.6			0.75	1.0	$\mu A$	
$I_{LPM3.5,RTC, TOT}$ Total Low-power mode 3.5 (LPM3.5) current with active RTC <sup>(11)</sup>	3 V		1.0		1.1		1.2	1.5	2.8	$\mu A$	
$I_{LPM4.5}$ Low-power mode 4.5 <sup>(12)</sup>	3 V		0.4		0.45	0.6	0.5	0.76	1.8	$\mu A$	

(7) Current for watchdog timer clocked by VLO included.

CPUOFF = 1, SCG0 = 1, SCG1 = 1, OSCOFF = 0 (LPM3),  $f_{ACLK} = f_{MCLK} = f_{SMCLK} = f_{DCO} = 0$  MHz  
USB disabled (VUSBEN = 0, SLDOEN = 0)

(8) CPUOFF = 1, SCG0 = 1, SCG1 = 1, OSCOFF = 1 (LPM4),  $f_{DCO} = f_{ACLK} = f_{MCLK} = f_{SMCLK} = 0$  MHz  
USB disabled (VUSBEN = 0, SLDOEN = 0)

(9)  $V_{VBAT} = V_{CC} - 0.2$  V,  $f_{DCO} = f_{MCLK} = f_{SMCLK} = 0$  MHz,  $f_{ACLK} = 32768$  Hz, PMMREGOFF = 1, RTC in backup domain active

(10)  $V_{VBAT} = V_{CC} - 0.2$  V,  $f_{DCO} = f_{MCLK} = f_{SMCLK} = 0$  MHz,  $f_{ACLK} = 32768$  Hz, PMMREGOFF = 1, RTC in backup domain active, no current drawn on VBAK

(11)  $f_{DCO} = f_{MCLK} = f_{SMCLK} = 0$  MHz,  $f_{ACLK} = 32768$  Hz, PMMREGOFF = 1, RTC in backup domain active, no current drawn on VBAK

(12) Internal regulator disabled. No data retention.

CPUOFF = 1, SCG0 = 1, SCG1 = 1, OSCOFF = 1, PMMREGOFF = 1 (LPM4.5),  $f_{DCO} = f_{ACLK} = f_{MCLK} = f_{SMCLK} = 0$  MHz

## 5.6 Low-Power Mode With LCD Supply Currents (Into $V_{CC}$ ) Excluding External Current

over recommended ranges of supply voltage and operating free-air temperature (unless otherwise noted)<sup>(1) (2)</sup>

PARAMETER	$V_{CC}$	PMMCOREVx	TEMPERATURE ( $T_A$ )								UNIT
			-40°C		25°C		60°C		85°C		
			TYP	MAX	TYP	MAX	TYP	MAX	TYP	MAX	
$I_{LPM3\ LCD, int. bias}$ Low-power mode 3 (LPM3) current, LCD 4-mux mode, internal biasing, charge pump disabled <sup>(3) (4)</sup>	3 V	0	2.7	3.3	4.8	4.7	9.5	28	$\mu A$		
		1	2.9	3.5		5.0	9.9				
		2	3.0	3.7		5.2	10.2				
		3	3.1	3.7	5.3	5.2	10.2	30			
$I_{LPM3\ LCD, CP}$ Low-power mode 3 (LPM3) current, LCD 4-mux mode, internal biasing, charge pump enabled <sup>(3) (5)</sup>	2.2 V	0		3.6					$\mu A$		
		1		3.7							
		2		4.0							
	3 V	0		3.5							
		1		3.7							
		2		3.8							
		3		3.9							

(1) All inputs are tied to 0 V or to  $V_{CC}$ . Outputs do not source or sink any current.

(2) The currents are characterized with a Micro Crystal CC4V-T1A SMD crystal with a load capacitance of 9 pF. The internal and external load capacitance are chosen to closely match the required 9 pF.

(3) Current for watchdog timer clocked by ACLK and RTC clocked by LFXT1 (32768 Hz) included. ACLK = low frequency crystal operation (XTS = 0, XT1DRIVEx = 0).

CPUOFF = 1, SCG0 = 1, SCG1 = 1, OSCOFF = 0 (LPM3),  $f_{ACLK}$  = 32768 Hz,  $f_{MCLK}$  =  $f_{SMCLK}$  =  $f_{DCO}$  = 0 MHz  
Current for brownout included. Low-side supervisor (SVSL) and low-side monitor (SVM<sub>L</sub>) disabled. High-side supervisor (SVSH) and high-side monitor (SVM<sub>H</sub>) disabled. RAM retention enabled.

(4) LCDMx = 11 (4-mux mode), LCDREXT = 0, LCDEXTBIAS = 0 (internal biasing), LCD2B = 0 (1/3 bias), LCDCPEN = 0 (charge pump disabled), LCDSSEL = 0, LCDPREx = 101, LCDDIVx = 00011 ( $f_{LCD}$  = 32768 Hz / 32 / 4 = 256 Hz)  
Even segments S0, S2, ... = 0, odd segments S1, S3, ... = 1. No LCD panel load.

(5) LCDMx = 11 (4-mux mode), LCDREXT = 0, LCDEXTBIAS = 0 (internal biasing), LCD2B = 0 (1/3 bias), LCDCPEN = 1 (charge pump enabled), VLCDx = 1000 ( $V_{LCD}$  = 3 V, typical), LCDSSEL = 0, LCDPREx = 101, LCDDIVx = 00011 ( $f_{LCD}$  = 32768 Hz / 32 / 4 = 256 Hz)  
Even segments S0, S2, ... = 0, odd segments S1, S3, ... = 1. No LCD panel load.

## 5.7 Thermal Resistance Characteristics

THERMAL METRIC		PACKAGE	VALUE	UNIT
$\theta_{JA}$	Junction-to-ambient thermal resistance, still air <sup>(1)</sup>	QFP (PZ)	122	°C/W
		BGA (ZQW)	108	
$\theta_{JC(TOP)}$	Junction-to-case (top) thermal resistance <sup>(2)</sup>	QFP (PZ)	83	°C/W
		BGA (ZQW)	72	
$\theta_{JB}$	Junction-to-board thermal resistance <sup>(3)</sup>	QFP (PZ)	98	°C/W
		BGA (ZQW)	76	

(1) The junction-to-ambient thermal resistance under natural convection is obtained in a simulation on a JEDEC-standard, High-K board, as specified in JESD51-7, in an environment described in JESD51-2a.

(2) The junction-to-case (top) thermal resistance is obtained by simulating a cold plate test on the package top. No specific JEDEC-standard test exists, but a close description can be found in the ANSI SEMI standard G30-88.

(3) The junction-to-board thermal resistance is obtained by simulating in an environment with a ring cold plate fixture to control the PCB temperature, as described in JESD51-8.

### 5.8 Schmitt-Trigger Inputs – General-Purpose I/O<sup>(1)</sup>

over recommended ranges of supply voltage and operating free-air temperature (unless otherwise noted)

PARAMETER	TEST CONDITIONS	V <sub>CC</sub>	MIN	TYP	MAX	UNIT
V <sub>IT+</sub> Positive-going input threshold voltage		1.8 V	0.80		1.40	V
		3 V	1.50		2.10	
V <sub>IT-</sub> Negative-going input threshold voltage		1.8 V	0.45		1.00	V
		3 V	0.75		1.65	
V <sub>hys</sub> Input voltage hysteresis (V <sub>IT+</sub> – V <sub>IT-</sub> )		1.8 V	0.3		0.8	V
		3 V	0.4		1.0	
R <sub>Pull</sub> Pullup or pulldown resistor <sup>(2)</sup>	For pullup: V <sub>IN</sub> = V <sub>SS</sub> For pulldown: V <sub>IN</sub> = V <sub>CC</sub>		20	35	50	kΩ
C <sub>I</sub> Input capacitance	V <sub>IN</sub> = V <sub>SS</sub> or V <sub>CC</sub>			5		pF

(1) The same parametrics apply to the clock input pin when the crystal bypass mode is used on XT1 (XIN) or XT2 (XT2IN).

(2) Also applies to  $\overline{\text{RST}}$  pin when pullup or pulldown resistor is enabled.

### 5.9 Inputs – Ports P1, P2, P3, and P4<sup>(1)</sup>

over recommended ranges of supply voltage and operating free-air temperature (unless otherwise noted)

PARAMETER	TEST CONDITIONS	V <sub>CC</sub>	MIN	MAX	UNIT
t <sub>(int)</sub> External interrupt timing <sup>(2)</sup>	Port P1, P2, P3, P4: P1.x to P4.x, External trigger pulse duration to set interrupt flag	2.2 V, 3 V	20		ns

(1) Some devices may contain additional ports with interrupts. See the block diagram and terminal function descriptions.

(2) An external signal sets the interrupt flag every time the minimum interrupt pulse duration t<sub>(int)</sub> is met. It may be set by trigger signals shorter than t<sub>(int)</sub>.

### 5.10 Leakage Current – General-Purpose I/O

over recommended ranges of supply voltage and operating free-air temperature (unless otherwise noted)

PARAMETER	TEST CONDITIONS	V <sub>CC</sub>	MIN	MAX	UNIT
I <sub>lkg(Px.y)</sub> High-impedance leakage current	See <sup>(1)(2)</sup>	1.8 V, 3 V		±50	nA

(1) The leakage current is measured with V<sub>SS</sub> or V<sub>CC</sub> applied to the corresponding pin(s), unless otherwise noted.

(2) The leakage of the digital port pins is measured individually. The port pin is selected for input, and the pullup or pulldown resistor is disabled.

### 5.11 Outputs – General-Purpose I/O (Full Drive Strength)

over recommended ranges of supply voltage and operating free-air temperature (unless otherwise noted)

PARAMETER	TEST CONDITIONS	V <sub>CC</sub>	MIN	MAX	UNIT
V <sub>OH</sub> High-level output voltage	I <sub>(OHmax)</sub> = –3 mA <sup>(1)</sup>	1.8 V	V <sub>CC</sub> – 0.25	V <sub>CC</sub>	V
	I <sub>(OHmax)</sub> = –10 mA <sup>(2)</sup>		V <sub>CC</sub> – 0.60	V <sub>CC</sub>	
	I <sub>(OHmax)</sub> = –5 mA <sup>(1)</sup>	3 V	V <sub>CC</sub> – 0.25	V <sub>CC</sub>	
	I <sub>(OHmax)</sub> = –15 mA <sup>(2)</sup>		V <sub>CC</sub> – 0.60	V <sub>CC</sub>	
V <sub>OL</sub> Low-level output voltage	I <sub>(OLmax)</sub> = 3 mA <sup>(1)</sup>	1.8 V	V <sub>SS</sub>	V <sub>SS</sub> + 0.25	V
	I <sub>(OLmax)</sub> = 10 mA <sup>(2)</sup>		V <sub>SS</sub>	V <sub>SS</sub> + 0.60	
	I <sub>(OLmax)</sub> = 5 mA <sup>(1)</sup>	3 V	V <sub>SS</sub>	V <sub>SS</sub> + 0.25	
	I <sub>(OLmax)</sub> = 15 mA <sup>(2)</sup>		V <sub>SS</sub>	V <sub>SS</sub> + 0.60	

(1) The maximum total current, I<sub>(OHmax)</sub> and I<sub>(OLmax)</sub>, for all outputs combined should not exceed ±48 mA to hold the maximum voltage drop specified.

(2) The maximum total current, I<sub>(OHmax)</sub> and I<sub>(OLmax)</sub>, for all outputs combined should not exceed ±100 mA to hold the maximum voltage drop specified.

## 5.12 Outputs – General-Purpose I/O (Reduced Drive Strength)

over recommended ranges of supply voltage and operating free-air temperature (unless otherwise noted)<sup>(1)</sup>

PARAMETER		TEST CONDITIONS	V <sub>CC</sub>	MIN	MAX	UNIT
V <sub>OH</sub>	High-level output voltage	I <sub>(OHmax)</sub> = -1 mA <sup>(2)</sup>	1.8 V	V <sub>CC</sub> - 0.25	V <sub>CC</sub>	V
		I <sub>(OHmax)</sub> = -3 mA <sup>(3)</sup>		V <sub>CC</sub> - 0.60	V <sub>CC</sub>	
		I <sub>(OHmax)</sub> = -2 mA <sup>(2)</sup>	3 V	V <sub>CC</sub> - 0.25	V <sub>CC</sub>	
		I <sub>(OHmax)</sub> = -6 mA <sup>(3)</sup>		V <sub>CC</sub> - 0.60	V <sub>CC</sub>	
V <sub>OL</sub>	Low-level output voltage	I <sub>(OLmax)</sub> = 1 mA <sup>(2)</sup>	1.8 V	V <sub>SS</sub>	V <sub>SS</sub> + 0.25	V
		I <sub>(OLmax)</sub> = 3 mA <sup>(3)</sup>		V <sub>SS</sub>	V <sub>SS</sub> + 0.60	
		I <sub>(OLmax)</sub> = 2 mA <sup>(2)</sup>	3 V	V <sub>SS</sub>	V <sub>SS</sub> + 0.25	
		I <sub>(OLmax)</sub> = 6 mA <sup>(3)</sup>		V <sub>SS</sub>	V <sub>SS</sub> + 0.60	

(1) Selecting reduced drive strength may reduce EMI.

(2) The maximum total current, I<sub>(OHmax)</sub> and I<sub>(OLmax)</sub>, for all outputs combined, should not exceed ±48 mA to hold the maximum voltage drop specified.

(3) The maximum total current, I<sub>(OHmax)</sub> and I<sub>(OLmax)</sub>, for all outputs combined, should not exceed ±100 mA to hold the maximum voltage drop specified.

## 5.13 Output Frequency – Ports P1, P2, and P3

over recommended ranges of supply voltage and operating free-air temperature (unless otherwise noted)

PARAMETER		TEST CONDITIONS	MIN	MAX	UNIT
f <sub>Px,y</sub>	Port output frequency (with load)	P3.4/TA2CLK/SMCLK/S27, C <sub>L</sub> = 20 pF, R <sub>L</sub> = 1 kΩ <sup>(1)</sup> or 3.2 kΩ <sup>(2)</sup> (3)	V <sub>CC</sub> = 1.8 V, PMMCOREVx = 0	8	MHz
			V <sub>CC</sub> = 3 V, PMMCOREVx = 3	20	
f <sub>Port_CLK</sub>	Clock output frequency	P1.0/TA0CLK/ACLK/S39, P3.4/TA2CLK/SMCLK/S27, P2.0/P2MAP0 (P2MAP0 = PM_MCLK), C <sub>L</sub> = 20 pF <sup>(3)</sup>	V <sub>CC</sub> = 1.8 V, PMMCOREVx = 0	8	MHz
			V <sub>CC</sub> = 3 V, PMMCOREVx = 3	20	

(1) Full drive strength of port: A resistive divider with 2 × 0.5 kΩ between V<sub>CC</sub> and V<sub>SS</sub> is used as load. The output is connected to the center tap of the divider.

(2) Reduced drive strength of port: A resistive divider with 2 × 1.6 kΩ between V<sub>CC</sub> and V<sub>SS</sub> is used as load. The output is connected to the center tap of the divider.

(3) The output voltage reaches at least 10% and 90% V<sub>CC</sub> at the specified toggle frequency.

### 5.14 Typical Characteristics – Outputs, Reduced Drive Strength (PxDS.y = 0)

over recommended ranges of supply voltage and operating free-air temperature (unless otherwise noted)

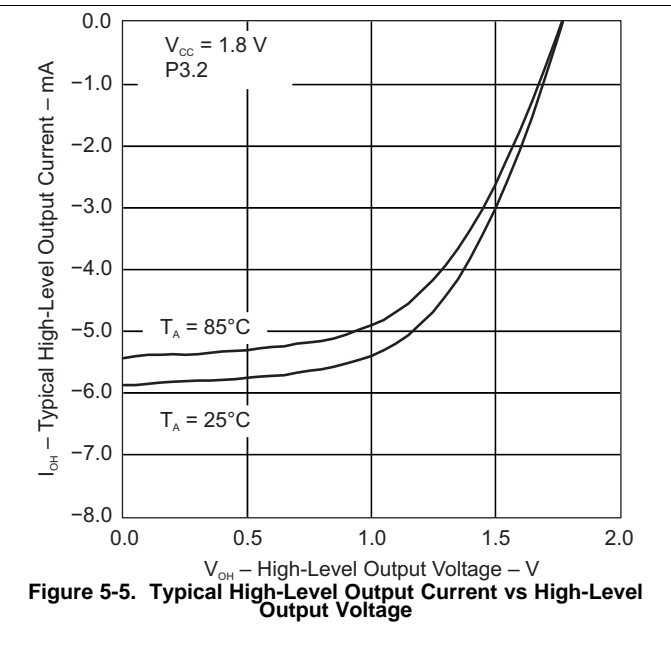
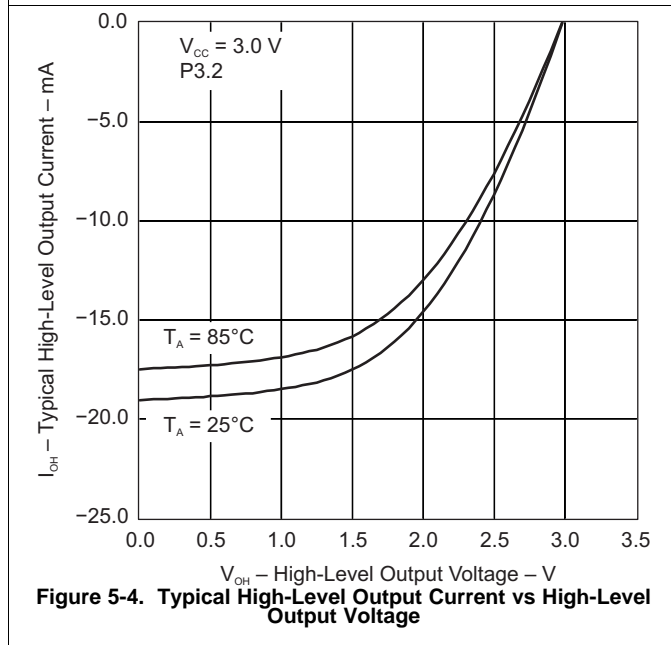
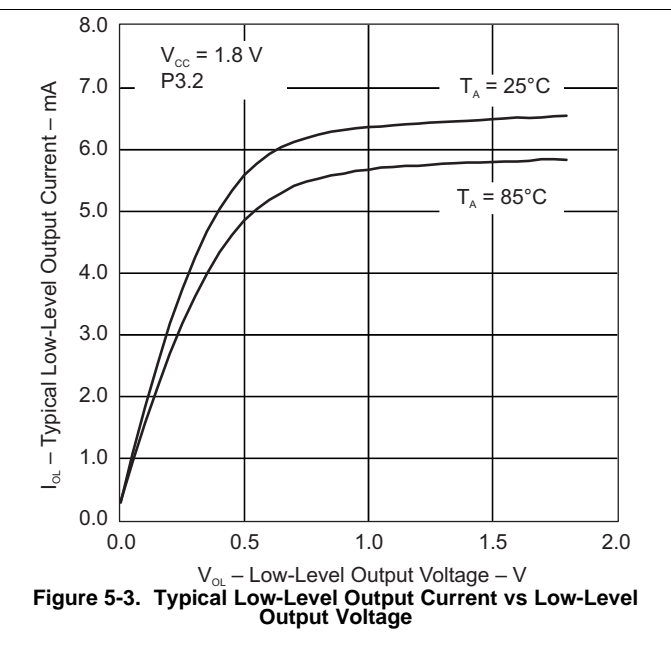
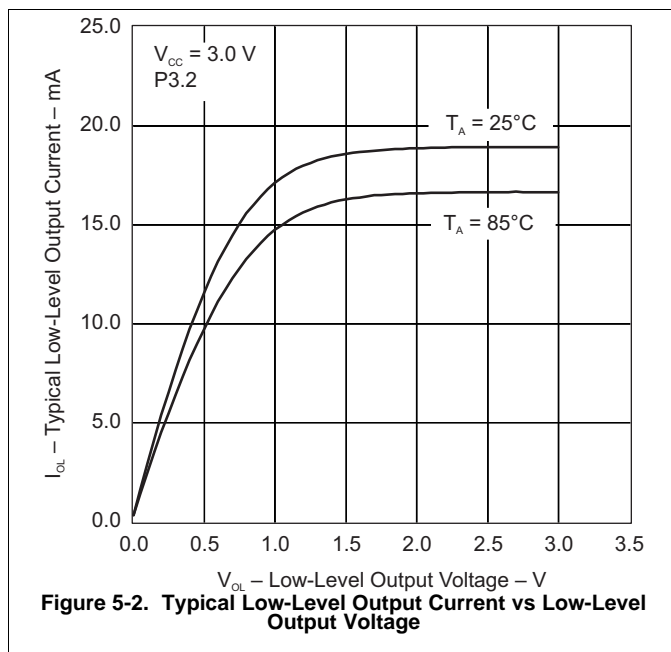

### 5.15 Typical Characteristics – Outputs, Full Drive Strength (PxDS.y = 1)

over recommended ranges of supply voltage and operating free-air temperature (unless otherwise noted)

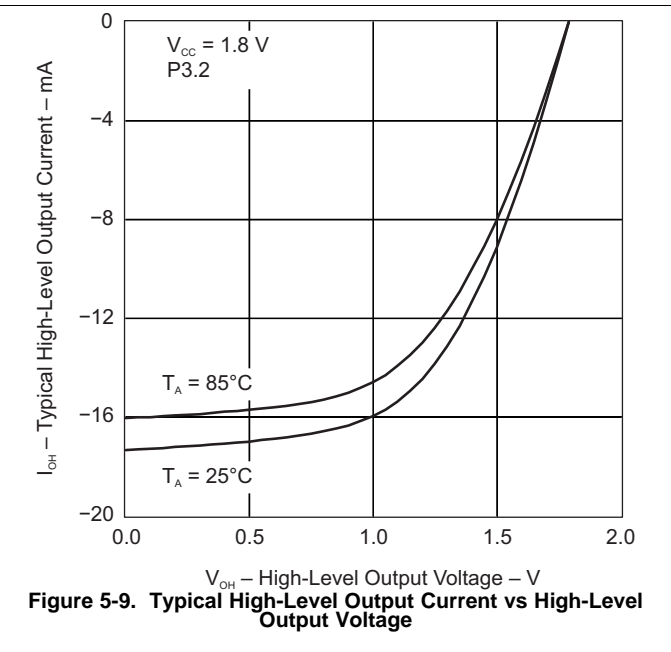
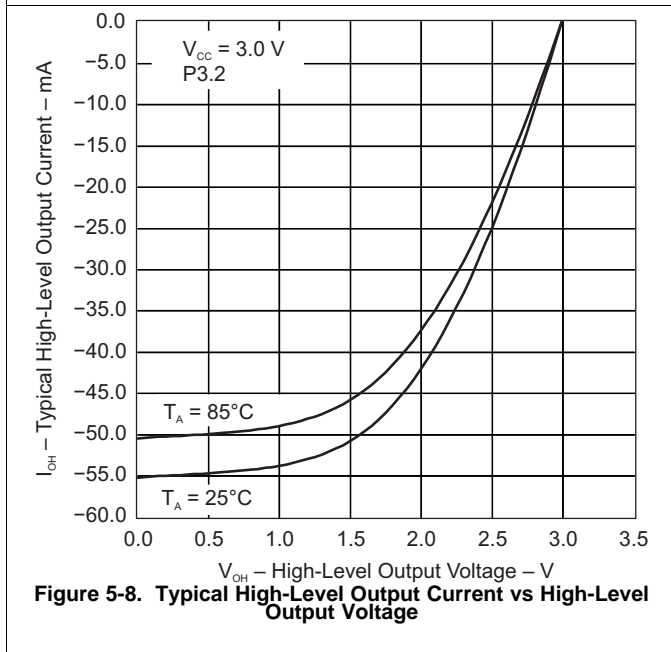
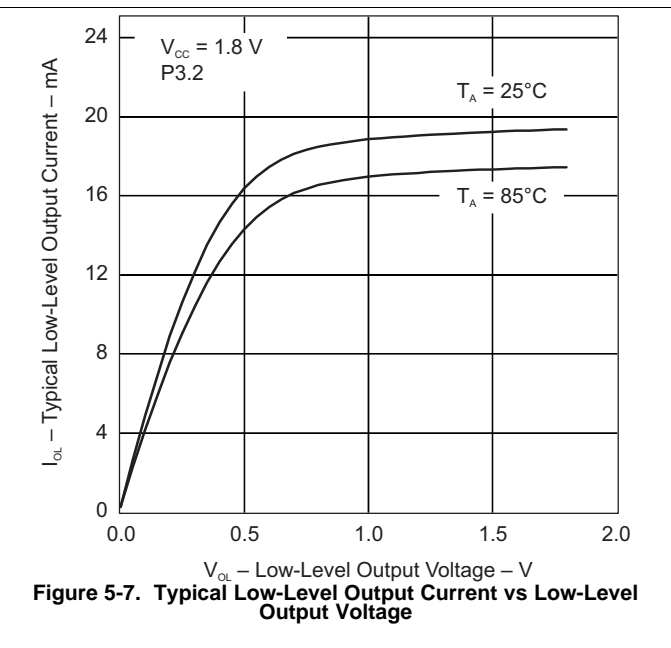
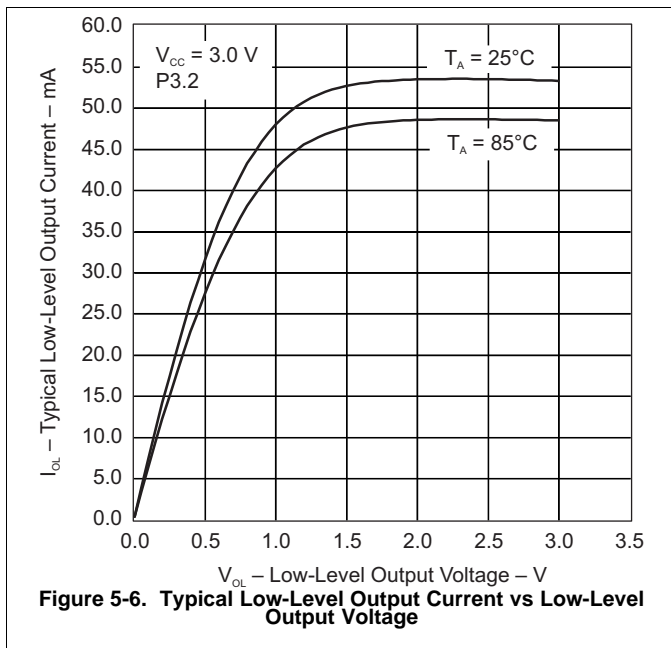

## 5.16 Crystal Oscillator, XT1, Low-Frequency Mode<sup>(1)</sup>

over recommended ranges of supply voltage and operating free-air temperature (unless otherwise noted)

PARAMETER	TEST CONDITIONS	V <sub>CC</sub>	MIN	TYP	MAX	UNIT
$\Delta I_{DVCC,LF}$	Differential XT1 oscillator crystal current consumption from lowest drive setting, LF mode	3 V		0.075		$\mu A$
	$f_{OSC} = 32768$ Hz, XTS = 0, XT1BYPASS = 0, XT1DRIVE <sub>x</sub> = 1, T <sub>A</sub> = 25°C					
	$f_{OSC} = 32768$ Hz, XTS = 0, XT1BYPASS = 0, XT1DRIVE <sub>x</sub> = 2, T <sub>A</sub> = 25°C					
	$f_{OSC} = 32768$ Hz, XTS = 0, XT1BYPASS = 0, XT1DRIVE <sub>x</sub> = 3, T <sub>A</sub> = 25°C			0.290		
$f_{XT1,LF0}$	XT1 oscillator crystal frequency, LF mode			32768		Hz
$f_{XT1,LF,SW}$	XT1 oscillator logic-level square-wave input frequency, LF mode		10	32.768	50	kHz
$OA_{LF}$	Oscillation allowance for LF crystals <sup>(4)</sup>	3 V		210		k $\Omega$
				$XTS = 0$ , XT1BYPASS = 0, XT1DRIVE <sub>x</sub> = 0, $f_{XT1,LF} = 32768$ Hz, C <sub>L,eff</sub> = 6 pF, T <sub>A</sub> = 25°C		
$C_{L,eff}$	Integrated effective load capacitance, LF mode <sup>(5)</sup>			1		pF
				$XTS = 0$ , XCAP <sub>x</sub> = 1		
				$XTS = 0$ , XCAP <sub>x</sub> = 2		
				$XTS = 0$ , XCAP <sub>x</sub> = 3		
	Duty cycle, LF mode		30%		70%	
$f_{Fault,LF}$	Oscillator fault frequency, LF mode <sup>(7)</sup>		10		10000	Hz
$t_{START,LF}$	Start-up time, LF mode	3 V		1000		ms
				$f_{OSC} = 32768$ Hz, XTS = 0, XT1BYPASS = 0, XT1DRIVE <sub>x</sub> = 0, T <sub>A</sub> = 25°C, C <sub>L,eff</sub> = 6 pF		
	$f_{OSC} = 32768$ Hz, XTS = 0, XT1BYPASS = 0, XT1DRIVE <sub>x</sub> = 3, T <sub>A</sub> = 25°C, C <sub>L,eff</sub> = 12 pF			500		

- (1) To improve EMI on the XT1 oscillator, the following guidelines should be observed.
  - Keep the trace between the device and the crystal as short as possible.
  - Design a good ground plane around the oscillator pins.
  - Prevent crosstalk from other clock or data lines into oscillator pins XIN and XOUT.
  - Avoid running PCB traces underneath or adjacent to the XIN and XOUT pins.
  - Use assembly materials and processes that avoid any parasitic load on the oscillator XIN and XOUT pins.
  - If conformal coating is used, make sure that it does not induce capacitive or resistive leakage between the oscillator pins.
- (2) When XT1BYPASS is set, XT1 circuit is automatically powered down. Input signal is a digital square wave with parametrics defined in the Schmitt-trigger Inputs section of this data sheet.
- (3) Maximum frequency of operation of the entire device cannot be exceeded.
- (4) Oscillation allowance is based on a safety factor of 5 for recommended crystals. The oscillation allowance is a function of the XT1DRIVE<sub>x</sub> settings and the effective load. In general, comparable oscillator allowance can be achieved based on the following guidelines, but should be evaluated based on the actual crystal selected for the application:
  - For XT1DRIVE<sub>x</sub> = 0, C<sub>L,eff</sub> ≤ 6 pF.
  - For XT1DRIVE<sub>x</sub> = 1, 6 pF ≤ C<sub>L,eff</sub> ≤ 9 pF.
  - For XT1DRIVE<sub>x</sub> = 2, 6 pF ≤ C<sub>L,eff</sub> ≤ 10 pF.
  - For XT1DRIVE<sub>x</sub> = 3, C<sub>L,eff</sub> ≥ 6 pF.
- (5) Includes parasitic bond and package capacitance (approximately 2 pF per pin). Because the PCB adds additional capacitance, verify the correct load by measuring the ACLK frequency. For a correct setup, the effective load capacitance should always match the specification of the used crystal.
- (6) Requires external capacitors at both terminals. Values are specified by crystal manufacturers.
- (7) Frequencies below the MIN specification set the fault flag. Frequencies above the MAX specification do not set the fault flag. Frequencies between the MIN and MAX specifications might set the flag.
- (8) Measured with logic-level input frequency but also applies to operation with crystals.

## 5.17 Crystal Oscillator, XT2

over recommended ranges of supply voltage and operating free-air temperature (unless otherwise noted)<sup>(1) (2)</sup>

PARAMETER		TEST CONDITIONS	V <sub>CC</sub>	MIN	TYP	MAX	UNIT
I <sub>DVCC,XT2</sub>	XT2 oscillator crystal current consumption	f <sub>OSC</sub> = 4 MHz, XT2OFF = 0, XT2BYPASS = 0, XT2DRIVE <sub>x</sub> = 0, T <sub>A</sub> = 25°C	3 V		200		μA
		f <sub>OSC</sub> = 12 MHz, XT2OFF = 0, XT2BYPASS = 0, XT2DRIVE <sub>x</sub> = 1, T <sub>A</sub> = 25°C			260		
		f <sub>OSC</sub> = 20 MHz, XT2OFF = 0, XT2BYPASS = 0, XT2DRIVE <sub>x</sub> = 2, T <sub>A</sub> = 25°C			325		
		f <sub>OSC</sub> = 32 MHz, XT2OFF = 0, XT2BYPASS = 0, XT2DRIVE <sub>x</sub> = 3, T <sub>A</sub> = 25°C			450		
f <sub>XT2,HF0</sub>	XT2 oscillator crystal frequency, mode 0	XT2DRIVE <sub>x</sub> = 0, XT2BYPASS = 0 <sup>(3)</sup>		4		8	MHz
f <sub>XT2,HF1</sub>	XT2 oscillator crystal frequency, mode 1	XT2DRIVE <sub>x</sub> = 1, XT2BYPASS = 0 <sup>(3)</sup>		8		16	MHz
f <sub>XT2,HF2</sub>	XT2 oscillator crystal frequency, mode 2	XT2DRIVE <sub>x</sub> = 2, XT2BYPASS = 0 <sup>(3)</sup>		16		24	MHz
f <sub>XT2,HF3</sub>	XT2 oscillator crystal frequency, mode 3	XT2DRIVE <sub>x</sub> = 3, XT2BYPASS = 0 <sup>(3)</sup>		24		32	MHz
f <sub>XT2,HF,SW</sub>	XT2 oscillator logic-level square-wave input frequency	XT2BYPASS = 1 <sup>(4) (3)</sup>		0.7		32	MHz
O <sub>AHF</sub>	Oscillation allowance for HF crystals <sup>(5)</sup>	XT2DRIVE <sub>x</sub> = 0, XT2BYPASS = 0, f <sub>XT2,HF0</sub> = 6 MHz, C <sub>L,eff</sub> = 15 pF, T <sub>A</sub> = 25°C	3 V		450		Ω
		XT2DRIVE <sub>x</sub> = 1, XT2BYPASS = 0, f <sub>XT2,HF1</sub> = 12 MHz, C <sub>L,eff</sub> = 15 pF, T <sub>A</sub> = 25°C			320		
		XT2DRIVE <sub>x</sub> = 2, XT2BYPASS = 0, f <sub>XT2,HF2</sub> = 20 MHz, C <sub>L,eff</sub> = 15 pF, T <sub>A</sub> = 25°C			200		
		XT2DRIVE <sub>x</sub> = 3, XT2BYPASS = 0, f <sub>XT2,HF3</sub> = 32 MHz, C <sub>L,eff</sub> = 15 pF, T <sub>A</sub> = 25°C			200		
t <sub>START,HF</sub>	Start-up time	f <sub>OSC</sub> = 6 MHz, XT2BYPASS = 0, XT2DRIVE <sub>x</sub> = 0, T <sub>A</sub> = 25°C, C <sub>L,eff</sub> = 15 pF	3 V		0.5		ms
		f <sub>OSC</sub> = 20 MHz, XT2BYPASS = 0, XT2DRIVE <sub>x</sub> = 3, T <sub>A</sub> = 25°C, C <sub>L,eff</sub> = 15 pF			0.3		
C <sub>L,eff</sub>	Integrated effective load capacitance, HF mode <sup>(6) (1)</sup>				1		pF
	Duty cycle	Measured at ACLK, f <sub>XT2,HF2</sub> = 20 MHz		40%	50%	60%	
f <sub>FAULT,HF</sub>	Oscillator fault frequency <sup>(7)</sup>	XT2BYPASS = 1 <sup>(8)</sup>		30		300	kHz

(1) Requires external capacitors at both terminals. Values are specified by crystal manufacturers.

(2) To improve EMI on the XT2 oscillator the following guidelines should be observed.

- Keep the traces between the device and the crystal as short as possible.
- Design a good ground plane around the oscillator pins.
- Prevent crosstalk from other clock or data lines into oscillator pins XT2IN and XT2OUT.
- Avoid running PCB traces underneath or adjacent to the XT2IN and XT2OUT pins.
- Use assembly materials and processes that avoid any parasitic load on the oscillator XT2IN and XT2OUT pins.
- If conformal coating is used, make sure that it does not induce capacitive or resistive leakage between the oscillator pins.

(3) Maximum frequency of operation of the entire device cannot be exceeded.

(4) When XT2BYPASS is set, the XT2 circuit is automatically powered down.

(5) Oscillation allowance is based on a safety factor of 5 for recommended crystals.

(6) Includes parasitic bond and package capacitance (approximately 2 pF per pin).

Because the PCB adds additional capacitance, verify the correct load by measuring the ACLK frequency. For a correct setup, the effective load capacitance should always match the specification of the used crystal.

(7) Frequencies below the MIN specification set the fault flag. Frequencies above the MAX specification do not set the fault flag.

Frequencies between the MIN and MAX specifications might set the flag.

(8) Measured with logic-level input frequency but also applies to operation with crystals.

## 5.18 Internal Very-Low-Power Low-Frequency Oscillator (VLO)

over recommended ranges of supply voltage and operating free-air temperature (unless otherwise noted)

PARAMETER		TEST CONDITIONS	V <sub>CC</sub>	MIN	TYP	MAX	UNIT
f <sub>VLO</sub>	VLO frequency	Measured at ACLK	1.8 V to 3.6 V	6	9.4	14	kHz
df <sub>VLO</sub> /dT	VLO frequency temperature drift	Measured at ACLK <sup>(1)</sup>	1.8 V to 3.6 V		0.5		%/°C
df <sub>VLO</sub> /dV <sub>CC</sub>	VLO frequency supply voltage drift	Measured at ACLK <sup>(2)</sup>	1.8 V to 3.6 V		4		%/V
	Duty cycle	Measured at ACLK	1.8 V to 3.6 V	40%	50%	60%	

(1) Calculated using the box method: (MAX(−40°C to 85°C) – MIN(−40°C to 85°C)) / MIN(−40°C to 85°C) / (85°C – (−40°C))

(2) Calculated using the box method: (MAX(1.8 V to 3.6 V) – MIN(1.8 V to 3.6 V)) / MIN(1.8 V to 3.6 V) / (3.6 V – 1.8 V)

## 5.19 Internal Reference, Low-Frequency Oscillator (REFO)

over recommended ranges of supply voltage and operating free-air temperature (unless otherwise noted)

PARAMETER		TEST CONDITIONS	V <sub>CC</sub>	MIN	TYP	MAX	UNIT
I <sub>REFO</sub>	REFO oscillator current consumption	T <sub>A</sub> = 25°C	1.8 V to 3.6 V		3		μA
f <sub>REFO</sub>	REFO frequency calibrated	Measured at ACLK	1.8 V to 3.6 V		32768		Hz
	REFO absolute tolerance calibrated	Full temperature range	1.8 V to 3.6 V			±3.5%	
		T <sub>A</sub> = 25°C	3 V			±1.5%	
df <sub>REFO</sub> /dT	REFO frequency temperature drift	Measured at ACLK <sup>(1)</sup>	1.8 V to 3.6 V		0.01		%/°C
df <sub>REFO</sub> /dV <sub>CC</sub>	REFO frequency supply voltage drift	Measured at ACLK <sup>(2)</sup>	1.8 V to 3.6 V		1.0		%/V
	Duty cycle	Measured at ACLK	1.8 V to 3.6 V	40%	50%	60%	
t <sub>START</sub>	REFO start-up time	40%/60% duty cycle	1.8 V to 3.6 V		25		μs

(1) Calculated using the box method: (MAX(−40°C to 85°C) – MIN(−40°C to 85°C)) / MIN(−40°C to 85°C) / (85°C – (−40°C))

(2) Calculated using the box method: (MAX(1.8 V to 3.6 V) – MIN(1.8 V to 3.6 V)) / MIN(1.8 V to 3.6 V) / (3.6 V – 1.8 V)

## 5.20 DCO Frequency

over recommended ranges of supply voltage and operating free-air temperature (unless otherwise noted)

PARAMETER		TEST CONDITIONS	MIN	TYP	MAX	UNIT
$f_{DCO(0,0)}$	DCO frequency (0, 0) <sup>(1)</sup>	DCORSELx = 0, DCOx = 0, MODx = 0	0.07		0.20	MHz
$f_{DCO(0,31)}$	DCO frequency (0, 31) <sup>(1)</sup>	DCORSELx = 0, DCOx = 31, MODx = 0	0.70		1.70	MHz
$f_{DCO(1,0)}$	DCO frequency (1, 0) <sup>(1)</sup>	DCORSELx = 1, DCOx = 0, MODx = 0	0.15		0.36	MHz
$f_{DCO(1,31)}$	DCO frequency (1, 31) <sup>(1)</sup>	DCORSELx = 1, DCOx = 31, MODx = 0	1.47		3.45	MHz
$f_{DCO(2,0)}$	DCO frequency (2, 0) <sup>(1)</sup>	DCORSELx = 2, DCOx = 0, MODx = 0	0.32		0.75	MHz
$f_{DCO(2,31)}$	DCO frequency (2, 31) <sup>(1)</sup>	DCORSELx = 2, DCOx = 31, MODx = 0	3.17		7.38	MHz
$f_{DCO(3,0)}$	DCO frequency (3, 0) <sup>(1)</sup>	DCORSELx = 3, DCOx = 0, MODx = 0	0.64		1.51	MHz
$f_{DCO(3,31)}$	DCO frequency (3, 31) <sup>(1)</sup>	DCORSELx = 3, DCOx = 31, MODx = 0	6.07		14.0	MHz
$f_{DCO(4,0)}$	DCO frequency (4, 0) <sup>(1)</sup>	DCORSELx = 4, DCOx = 0, MODx = 0	1.3		3.2	MHz
$f_{DCO(4,31)}$	DCO frequency (4, 31) <sup>(1)</sup>	DCORSELx = 4, DCOx = 31, MODx = 0	12.3		28.2	MHz
$f_{DCO(5,0)}$	DCO frequency (5, 0) <sup>(1)</sup>	DCORSELx = 5, DCOx = 0, MODx = 0	2.5		6.0	MHz
$f_{DCO(5,31)}$	DCO frequency (5, 31) <sup>(1)</sup>	DCORSELx = 5, DCOx = 31, MODx = 0	23.7		54.1	MHz
$f_{DCO(6,0)}$	DCO frequency (6, 0) <sup>(1)</sup>	DCORSELx = 6, DCOx = 0, MODx = 0	4.6		10.7	MHz
$f_{DCO(6,31)}$	DCO frequency (6, 31) <sup>(1)</sup>	DCORSELx = 6, DCOx = 31, MODx = 0	39.0		88.0	MHz
$f_{DCO(7,0)}$	DCO frequency (7, 0) <sup>(1)</sup>	DCORSELx = 7, DCOx = 0, MODx = 0	8.5		19.6	MHz
$f_{DCO(7,31)}$	DCO frequency (7, 31) <sup>(1)</sup>	DCORSELx = 7, DCOx = 31, MODx = 0	60		135	MHz
$S_{DCORSEL}$	Frequency step between range DCORSEL and DCORSEL + 1	$S_{RSEL} = f_{DCO(DCORSEL+1,DCO)} / f_{DCO(DCORSEL,DCO)}$	1.2		2.3	ratio
$S_{DCO}$	Frequency step between tap DCO and DCO + 1	$S_{DCO} = f_{DCO(DCORSEL,DCO+1)} / f_{DCO(DCORSEL,DCO)}$	1.02		1.12	ratio
	Duty cycle	Measured at SMCLK	40%	50%	60%	
$df_{DCO}/dT$	DCO frequency temperature drift	$f_{DCO} = 1 \text{ MHz}$		0.1		%/°C
$df_{DCO}/dV_{CC}$	DCO frequency voltage drift	$f_{DCO} = 1 \text{ MHz}$		1.9		%/V

- (1) When selecting the proper DCO frequency range (DCORSELx), the target DCO frequency,  $f_{DCO}$ , should be set to reside within the range of  $f_{DCO(n,0),MAX} \leq f_{DCO} \leq f_{DCO(n,31),MIN}$ , where  $f_{DCO(n,0),MAX}$  represents the maximum frequency specified for the DCO frequency, range n, tap 0 (DCOx = 0) and  $f_{DCO(n,31),MIN}$  represents the minimum frequency specified for the DCO frequency, range n, tap 31 (DCOx = 31). This ensures that the target DCO frequency resides within the range selected. If the actual  $f_{DCO}$  frequency for the selected range causes the FLL or the application to select tap 0 or 31, the DCO fault flag is set to report that the selected range is at its minimum or maximum tap setting.

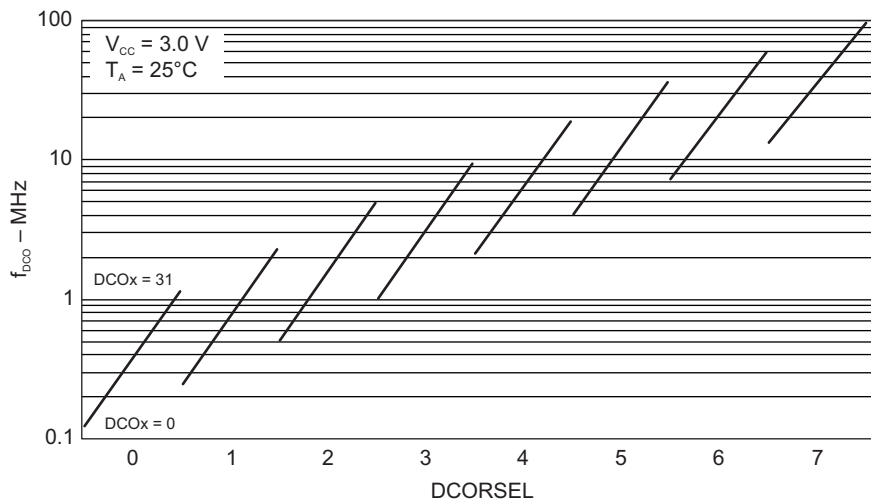

Figure 5-10. Typical DCO Frequency

## 5.21 PMM, Brownout Reset (BOR)

over recommended ranges of supply voltage and operating free-air temperature (unless otherwise noted)

PARAMETER		TEST CONDITIONS	MIN	TYP	MAX	UNIT
$V_{(DVCC\_BOR\_IT-)}$	BOR <sub>H</sub> on voltage, DV <sub>CC</sub> falling level	$ dDV_{CC}/dt  < 3 \text{ V/s}$			1.45	V
$V_{(DVCC\_BOR\_IT+)}$	BOR <sub>H</sub> off voltage, DV <sub>CC</sub> rising level	$ dDV_{CC}/dt  < 3 \text{ V/s}$	0.80	1.30	1.50	V
$V_{(DVCC\_BOR\_hys)}$	BOR <sub>H</sub> hysteresis		50		250	mV
$t_{RESET}$	Pulse duration required at $\overline{RST}/NMI$ pin to accept a reset		2			μs

## 5.22 PMM, Core Voltage

over recommended ranges of supply voltage and operating free-air temperature (unless otherwise noted)

PARAMETER		TEST CONDITIONS	MIN	TYP	MAX	UNIT
$V_{CORE3(AM)}$	Core voltage, active mode, PMMCOREV = 3	$2.4 \text{ V} \leq DV_{CC} \leq 3.6 \text{ V}, 0 \text{ mA} \leq I(V_{CORE}) \leq 21 \text{ mA}$		1.90		V
$V_{CORE2(AM)}$	Core voltage, active mode, PMMCOREV = 2	$2.2 \text{ V} \leq DV_{CC} \leq 3.6 \text{ V}, 0 \text{ mA} \leq I(V_{CORE}) \leq 21 \text{ mA}$		1.80		V
$V_{CORE1(AM)}$	Core voltage, active mode, PMMCOREV = 1	$2 \text{ V} \leq DV_{CC} \leq 3.6 \text{ V}, 0 \text{ mA} \leq I(V_{CORE}) \leq 17 \text{ mA}$		1.60		V
$V_{CORE0(AM)}$	Core voltage, active mode, PMMCOREV = 0	$1.8 \text{ V} \leq DV_{CC} \leq 3.6 \text{ V}, 0 \text{ mA} \leq I(V_{CORE}) \leq 13 \text{ mA}$		1.40		V
$V_{CORE3(LPM)}$	Core voltage, low-current mode, PMMCOREV = 3	$2.4 \text{ V} \leq DV_{CC} \leq 3.6 \text{ V}, 0 \mu\text{A} \leq I(V_{CORE}) \leq 30 \mu\text{A}$		1.94		V
$V_{CORE2(LPM)}$	Core voltage, low-current mode, PMMCOREV = 2	$2.2 \text{ V} \leq DV_{CC} \leq 3.6 \text{ V}, 0 \mu\text{A} \leq I(V_{CORE}) \leq 30 \mu\text{A}$		1.84		V
$V_{CORE1(LPM)}$	Core voltage, low-current mode, PMMCOREV = 1	$2 \text{ V} \leq DV_{CC} \leq 3.6 \text{ V}, 0 \mu\text{A} \leq I(V_{CORE}) \leq 30 \mu\text{A}$		1.64		V
$V_{CORE0(LPM)}$	Core voltage, low-current mode, PMMCOREV = 0	$1.8 \text{ V} \leq DV_{CC} \leq 3.6 \text{ V}, 0 \mu\text{A} \leq I(V_{CORE}) \leq 30 \mu\text{A}$		1.44		V

### 5.23 PMM, SVS High Side

over recommended ranges of supply voltage and operating free-air temperature (unless otherwise noted)

PARAMETER	TEST CONDITIONS	MIN	TYP	MAX	UNIT
$I_{(SVSH)}$ SVS current consumption	SVSHE = 0, DV <sub>CC</sub> = 3.6 V		0		nA
	SVSHE = 1, DV <sub>CC</sub> = 3.6 V, SVSHFP = 0		200		
	SVSHE = 1, DV <sub>CC</sub> = 3.6 V, SVSHFP = 1		2.0		μA
$V_{(SVSH\_IT-)}$ SVS <sub>H</sub> on voltage level <sup>(1)</sup>	SVSHE = 1, SVSHRVL = 0	1.59	1.64	1.69	V
	SVSHE = 1, SVSHRVL = 1	1.79	1.84	1.91	
	SVSHE = 1, SVSHRVL = 2	1.98	2.04	2.11	
	SVSHE = 1, SVSHRVL = 3	2.10	2.16	2.23	
$V_{(SVSH\_IT+)}$ SVS <sub>H</sub> off voltage level <sup>(1)</sup>	SVSHE = 1, SVSMHRRRL = 0	1.62	1.74	1.81	V
	SVSHE = 1, SVSMHRRRL = 1	1.88	1.94	2.01	
	SVSHE = 1, SVSMHRRRL = 2	2.07	2.14	2.21	
	SVSHE = 1, SVSMHRRRL = 3	2.20	2.26	2.33	
	SVSHE = 1, SVSMHRRRL = 4	2.32	2.40	2.48	
	SVSHE = 1, SVSMHRRRL = 5	2.56	2.70	2.84	
	SVSHE = 1, SVSMHRRRL = 6	2.85	3.00	3.15	
	SVSHE = 1, SVSMHRRRL = 7	2.85	3.00	3.15	
$t_{pd(SVSH)}$ SVS <sub>H</sub> propagation delay	SVSHE = 1, dV <sub>DVCC</sub> /dt = 10 mV/μs, SVSHFP = 1		2.5		μs
	SVSHE = 1, dV <sub>DVCC</sub> /dt = 1 mV/μs, SVSHFP = 0		20		
$t_{(SVSH)}$ SVS <sub>H</sub> on or off delay time	SVSHE = 0→1, SVSHFP = 1		12.5		μs
	SVSHE = 0→1, SVSHFP = 0		100		
dV <sub>DVCC</sub> /dt DV <sub>CC</sub> rise time		0		1000	V/s

(1) The SVS<sub>H</sub> settings available depend on the VCore (PMMCOREVx) setting. See the *Power Management Module and Supply Voltage Supervisor* chapter in the [MSP430x5xx and MSP430x6xx Family User's Guide](#) on recommended settings and usage.

### 5.24 PMM, SVM High Side

over recommended ranges of supply voltage and operating free-air temperature (unless otherwise noted)

PARAMETER	TEST CONDITIONS	MIN	TYP	MAX	UNIT
$I_{(SVMH)}$ SVM <sub>H</sub> current consumption	SVMHE = 0, DV <sub>CC</sub> = 3.6 V		0		nA
	SVMHE = 1, DV <sub>CC</sub> = 3.6 V, SVMHFP = 0		200		
	SVMHE = 1, DV <sub>CC</sub> = 3.6 V, SVMHFP = 1		2.0		μA
$V_{(SVMH)}$ SVM <sub>H</sub> on or off voltage level <sup>(1)</sup>	SVMHE = 1, SVSMHRRRL = 0	1.65	1.74	1.86	V
	SVMHE = 1, SVSMHRRRL = 1	1.85	1.94	2.02	
	SVMHE = 1, SVSMHRRRL = 2	2.02	2.14	2.22	
	SVMHE = 1, SVSMHRRRL = 3	2.18	2.26	2.35	
	SVMHE = 1, SVSMHRRRL = 4	2.32	2.40	2.48	
	SVMHE = 1, SVSMHRRRL = 5	2.56	2.70	2.84	
	SVMHE = 1, SVSMHRRRL = 6	2.85	3.00	3.15	
	SVMHE = 1, SVSMHRRRL = 7	2.85	3.00	3.15	
	SVMHE = 1, SVMHOVPE = 1		3.75		
$t_{pd(SVMH)}$ SVM <sub>H</sub> propagation delay	SVMHE = 1, dV <sub>DVCC</sub> /dt = 10 mV/μs, SVMHFP = 1		2.5		μs
	SVMHE = 1, dV <sub>DVCC</sub> /dt = 1 mV/μs, SVMHFP = 0		20		
$t_{(SVMH)}$ SVM <sub>H</sub> on or off delay time	SVMHE = 0→1, SVMHFP = 1		12.5		μs
	SVMHE = 0→1, SVMHFP = 0		100		

(1) The SVM<sub>H</sub> settings available depend on the VCore (PMMCOREVx) setting. See the *Power Management Module and Supply Voltage Supervisor* chapter in the [MSP430x5xx and MSP430x6xx Family User's Guide](#) on recommended settings and usage.

## 5.25 PMM, SVS Low Side

over recommended ranges of supply voltage and operating free-air temperature (unless otherwise noted)

PARAMETER		TEST CONDITIONS	MIN	TYP	MAX	UNIT
$I_{(SVSL)}$	SVS <sub>L</sub> current consumption	SVSLE = 0, PMMCOREV = 2		0		nA
		SVSLE = 1, PMMCOREV = 2, SVSLFP = 0		200		
		SVSLE = 1, PMMCOREV = 2, SVSLFP = 1		2.0		μA
$t_{pd(SVSL)}$	SVS <sub>L</sub> propagation delay	SVSLE = 1, $dV_{CORE}/dt = 10 \text{ mV}/\mu\text{s}$ , SVSLFP = 1		2.5		μs
		SVSLE = 1, $dV_{CORE}/dt = 1 \text{ mV}/\mu\text{s}$ , SVSLFP = 0		20		
$t_{(SVSL)}$	SVS <sub>L</sub> on or off delay time	SVSLE = 0→1, SVSLFP = 1		12.5		μs
		SVSLE = 0→1, SVSLFP = 0		100		

## 5.26 PMM, SVM Low Side

over recommended ranges of supply voltage and operating free-air temperature (unless otherwise noted)

PARAMETER		TEST CONDITIONS	MIN	TYP	MAX	UNIT
$I_{(SVM_L)}$	SVM <sub>L</sub> current consumption	SVMLE = 0, PMMCOREV = 2		0		nA
		SVMLE = 1, PMMCOREV = 2, SVM_LFP = 0		200		
		SVMLE = 1, PMMCOREV = 2, SVM_LFP = 1		2.0		μA
$t_{pd(SVM_L)}$	SVM <sub>L</sub> propagation delay	SVMLE = 1, $dV_{CORE}/dt = 10 \text{ mV}/\mu\text{s}$ , SVM_LFP = 1		2.5		μs
		SVMLE = 1, $dV_{CORE}/dt = 1 \text{ mV}/\mu\text{s}$ , SVM_LFP = 0		20		
$t_{(SVM_L)}$	SVM <sub>L</sub> on or off delay time	SVMLE = 0→1, SVM_LFP = 1		12.5		μs
		SVMLE = 0→1, SVM_LFP = 0		100		

## 5.27 Wake-up Times From Low-Power Modes

over recommended ranges of supply voltage and operating free-air temperature (unless otherwise noted)

PARAMETER		TEST CONDITIONS	MIN	TYP	MAX	UNIT
$t_{\text{WAKE-UP-FAST}}$	Wake-up time from LPM2, LPM3, or LPM4 to active mode <sup>(1)</sup>	PMMCOREV = SVSMLRRL = n (where n = 0, 1, 2, or 3), SVSLFP = 1, $f_{MCLK} \geq 4.0 \text{ MHz}$		3	6.5	μs
		PMMCOREV = SVSMLRRL = n (where n = 0, 1, 2, or 3), SVSLFP = 1, $1 \text{ MHz} < f_{MCLK} < 4.0 \text{ MHz}$		4	8.0	
$t_{\text{WAKE-UP-SLOW}}$	Wake-up time from LPM2, LPM3, or LPM4 to active mode <sup>(2)(3)</sup>	PMMCOREV = SVSMLRRL = n (where n = 0, 1, 2, or 3), SVSLFP = 0		150	165	
$t_{\text{WAKE-UP LPM5}}$	Wake-up time from LPM3.5 or LPM4.5 to active mode <sup>(4)</sup>			2	3	ms
$t_{\text{WAKE-UP-RESET}}$	Wake-up time from RST or BOR event to active mode <sup>(4)</sup>			2	3	ms

- (1) This value represents the time from the wake-up event to the first active edge of MCLK. The wake-up time depends on the performance mode of the low-side supervisor (SVS<sub>L</sub>) and low-side monitor (SVM<sub>L</sub>).  $t_{\text{WAKE-UP-FAST}}$  is possible with SVS<sub>L</sub> and SVM<sub>L</sub> in full performance mode or disabled. For specific register settings, see the *Low-Side SVS and SVM Control and Performance Mode Selection* section in the *Power Management Module and Supply Voltage Supervisor* chapter of the [MSP430x5xx and MSP430x6xx Family User's Guide](#).
- (2) This value represents the time from the wake-up event to the first active edge of MCLK. The wake-up time depends on the performance mode of the low-side supervisor (SVS<sub>L</sub>) and low-side monitor (SVM<sub>L</sub>).  $t_{\text{WAKE-UP-SLOW}}$  is set with SVS<sub>L</sub> and SVM<sub>L</sub> in normal mode (low current mode). For specific register settings, see the *Low-Side SVS and SVM Control and Performance Mode Selection* section in the *Power Management Module and Supply Voltage Supervisor* chapter of the [MSP430x5xx and MSP430x6xx Family User's Guide](#).
- (3) The wake-up times from LPM0 and LPM1 to AM are not specified. They are proportional to MCLK cycle time but are not affected by the performance mode settings as for LPM2, LPM3, and LPM4.
- (4) This value represents the time from the wake-up event to the reset vector execution.

## 5.28 Timer\_A – Timers TA0, TA1, and TA2

over recommended ranges of supply voltage and operating free-air temperature (unless otherwise noted)

PARAMETER		TEST CONDITIONS	V <sub>CC</sub>	MIN	MAX	UNIT
f <sub>TA</sub>	Timer_A input clock frequency	Internal: SMCLK or ACLK, External: TACLK, Duty cycle = 50% ±10%	1.8 V, 3 V		20	MHz
t <sub>TA,cap</sub>	Timer_A capture timing	All capture inputs, Minimum pulse duration required for capture	1.8 V, 3 V	20		ns

## 5.29 Timer\_B – Timer TB0

over recommended ranges of supply voltage and operating free-air temperature (unless otherwise noted)

PARAMETER		TEST CONDITIONS	V <sub>CC</sub>	MIN	MAX	UNIT
f <sub>TB</sub>	Timer_B input clock frequency	Internal: SMCLK or ACLK, External: TBCLK, Duty cycle = 50% ±10%	1.8 V, 3 V		20	MHz
t <sub>TB,cap</sub>	Timer_B capture timing	All capture inputs, Minimum pulse duration required for capture	1.8 V, 3 V	20		ns

## 5.30 Battery Backup

over operating free-air temperature range (unless otherwise noted)

PARAMETER		TEST CONDITIONS	V <sub>CC</sub>	MIN	TYP	MAX	UNIT
I <sub>VBAT</sub>	Current into VBAT terminal if no primary battery is connected	VBAT = 1.7 V, DVCC not connected, RTC running	0 V		T <sub>A</sub> = -40°C	0.43	μA
					T <sub>A</sub> = 25°C	0.52	
					T <sub>A</sub> = 60°C	0.58	
					T <sub>A</sub> = 85°C	0.66	
		VBAT = 2.2 V, DVCC not connected, RTC running			T <sub>A</sub> = -40°C	0.50	
					T <sub>A</sub> = 25°C	0.59	
					T <sub>A</sub> = 60°C	0.64	
					T <sub>A</sub> = 85°C	0.72	
		VBAT = 3 V, DVCC not connected, RTC running			T <sub>A</sub> = -40°C	0.68	
					T <sub>A</sub> = 25°C	0.75	
					T <sub>A</sub> = 60°C	0.79	
					T <sub>A</sub> = 85°C	0.87	
V <sub>SWITCH</sub>	Switch-over level (V <sub>CC</sub> to VBAT) C <sub>VCC</sub> = 4.7 μF	General	0 V		V <sub>SVSH_IT-</sub>		V
		SVSHRL = 0			1.59	1.69	
		SVSHRL = 1			1.79	1.91	
		SVSHRL = 2			1.98	2.11	
		SVSHRL = 3			2.10	2.23	
R <sub>ON_VBAT</sub>	On-resistance of switch between VBAT and VBAK	V <sub>BAT</sub> = 1.8 V	0 V		0.35	1	kΩ
V <sub>BAT3</sub>	VBAT to ADC input channel 12: V <sub>BAT</sub> divided, V <sub>BAT3</sub> ≈ V <sub>BAT</sub> /3		1.8 V		0.6	±5%	V
			3 V		1.0	±5%	
			3.6 V		1.2	±5%	
t <sub>Sample, VBAT3</sub>	VBAT to ADC: Sampling time required if VBAT3 selected	ADC12ON = 1, Error of conversion result ≤ 2 LSB		1000			ns
V <sub>CHVx</sub>	Charger end voltage	CHVx = 2		2.65	2.7	2.9	V
R <sub>CHARGE</sub>	Charge limiting resistor	CHCx = 1				5.2	kΩ
		CHCx = 2				10.2	
		CHCx = 3				20	

### 5.31 USCI (UART Mode)

over recommended ranges of supply voltage and operating free-air temperature (unless otherwise noted)

PARAMETER		TEST CONDITIONS	V <sub>CC</sub>	MIN	MAX	UNIT
f <sub>USCI</sub>	USCI input clock frequency	Internal: SMCLK or ACLK, External: UCLK Duty cycle = 50% ±10%			f <sub>SYSTEM</sub>	MHz
f <sub>BITCLK</sub>	BITCLK clock frequency (equals baud rate in Mbaud)				1	MHz
t <sub>r</sub>	UART receive deglitch time <sup>(1)</sup>		2.2 V	50	600	ns
			3 V	50	600	

(1) Pulses on the UART receive input (UCxRX) shorter than the UART receive deglitch time are suppressed. To make sure that pulses are correctly recognized, their duration should exceed the maximum specification of the deglitch time.

### 5.32 USCI (SPI Master Mode)

over recommended ranges of supply voltage and operating free-air temperature (unless otherwise noted)<sup>(1)</sup>

(see [Figure 5-11](#) and )

PARAMETER		TEST CONDITIONS	V <sub>CC</sub>	MIN	MAX	UNIT
f <sub>USCI</sub>	USCI input clock frequency	SMCLK or ACLK, Duty cycle = 50% ±10%			f <sub>SYSTEM</sub>	MHz
t <sub>SU,MI</sub>	SOMI input data setup time	PMMCOREV = 0	1.8 V	55		ns
			3 V	38		
		PMMCOREV = 3	2.4 V	30		
			3 V	25		
t <sub>HD,MI</sub>	SOMI input data hold time	PMMCOREV = 0	1.8 V	0		ns
			3 V	0		
		PMMCOREV = 3	2.4 V	0		
			3 V	0		
t <sub>VALID,MO</sub>	SIMO output data valid time <sup>(2)</sup>	UCLK edge to SIMO valid, C <sub>L</sub> = 20 pF, PMMCOREV = 0	1.8 V		20	ns
			3 V		18	
		UCLK edge to SIMO valid, C <sub>L</sub> = 20 pF, PMMCOREV = 3	2.4 V		16	
			3 V		15	
t <sub>HD,MO</sub>	SIMO output data hold time <sup>(3)</sup>	C <sub>L</sub> = 20 pF, PMMCOREV = 0	1.8 V	-10		ns
			3 V	-8		
		C <sub>L</sub> = 20 pF, PMMCOREV = 3	2.4 V	-10		
			3 V	-8		

(1)  $f_{UCXCLK} = 1/2t_{LO/HI}$  with  $t_{LO/HI} \geq \max(t_{VALID,MO(USCI)} + t_{SU,SI(Slave)}, t_{SU,MI(USCI)} + t_{VALID,SO(Slave)})$

For the slave parameters  $t_{SU,SI(Slave)}$  and  $t_{VALID,SO(Slave)}$ , see the SPI parameters of the attached slave.

(2) Specifies the time to drive the next valid data to the SIMO output after the output changing UCLK clock edge. See the timing diagrams in [Figure 5-11](#) and [Figure 5-12](#).

(3) Specifies how long data on the SIMO output is valid after the output changing UCLK clock edge. Negative values indicate that the data on the SIMO output can become invalid before the output changing clock edge observed on UCLK. See the timing diagrams in [Figure 5-11](#) and [Figure 5-12](#).

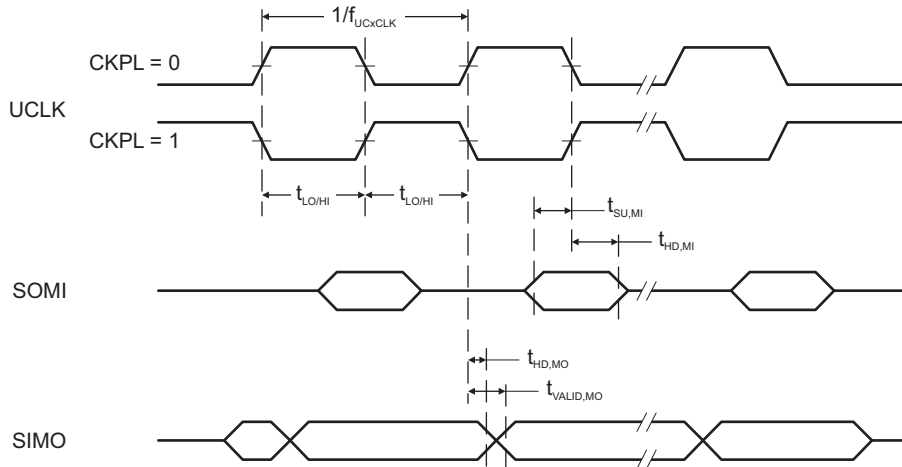

Figure 5-11. SPI Master Mode, CKPH = 0

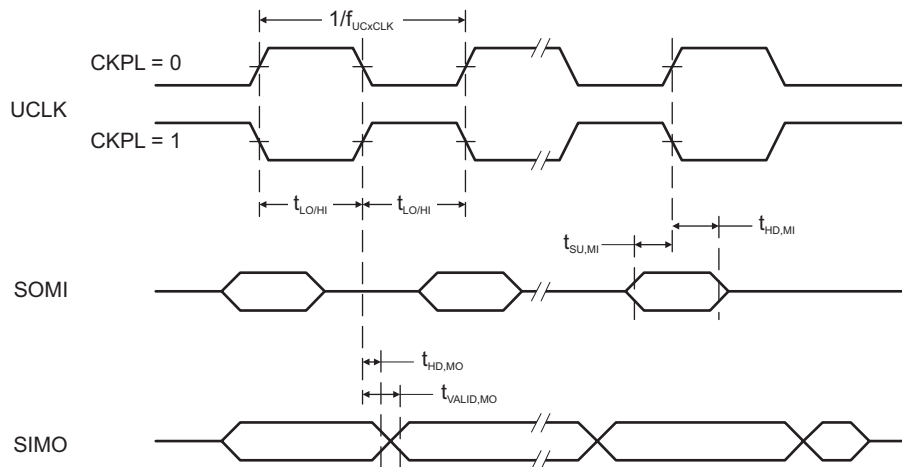

Figure 5-12. SPI Master Mode, CKPH = 1

### 5.33 USCI (SPI Slave Mode)

over recommended ranges of supply voltage and operating free-air temperature (unless otherwise noted)<sup>(1)</sup>  
(see [Figure 5-13](#) and [Figure 5-14](#))

PARAMETER		TEST CONDITIONS	V <sub>CC</sub>	MIN	MAX	UNIT
t <sub>STE,LEAD</sub>	STE lead time, STE low to clock	PMMCOREV = 0	1.8 V	11	ns	
			3 V	8		
		PMMCOREV = 3	2.4 V	7		
			3 V	6		
t <sub>STE,LAG</sub>	STE lag time, last clock to STE high	PMMCOREV = 0	1.8 V	1	ns	
			3 V	1		
		PMMCOREV = 3	2.4 V	1		
			3 V	1		
t <sub>STE,ACC</sub>	STE access time, STE low to SOMI data out	PMMCOREV = 0	1.8 V	66	ns	
			3 V	50		
		PMMCOREV = 3	2.4 V	36		
			3 V	30		
t <sub>STE,DIS</sub>	STE disable time, STE high to SOMI high impedance	PMMCOREV = 0	1.8 V	30	ns	
			3 V	30		
		PMMCOREV = 3	2.4 V	30		
			3 V	30		
t <sub>SU,SI</sub>	SIMO input data setup time	PMMCOREV = 0	1.8 V	5	ns	
			3 V	5		
		PMMCOREV = 3	2.4 V	2		
			3 V	2		
t <sub>HD,SI</sub>	SIMO input data hold time	PMMCOREV = 0	1.8 V	5	ns	
			3 V	5		
		PMMCOREV = 3	2.4 V	5		
			3 V	5		
t <sub>VALID,SO</sub>	SOMI output data valid time <sup>(2)</sup>	UCLK edge to SOMI valid, C <sub>L</sub> = 20 pF, PMMCOREV = 0	1.8 V	76	ns	
			3 V	60		
		UCLK edge to SOMI valid, C <sub>L</sub> = 20 pF, PMMCOREV = 3	2.4 V	44		
			3 V	40		
t <sub>HD,SO</sub>	SOMI output data hold time <sup>(3)</sup>	C <sub>L</sub> = 20 pF, PMMCOREV = 0	1.8 V	12	ns	
			3 V	12		
		C <sub>L</sub> = 20 pF, PMMCOREV = 3	2.4 V	12		
			3 V	12		

- (1)  $t_{UCxCLK} = 1/2t_{LO/HI}$  with  $t_{LO/HI} \geq \max(t_{VALID,MO(Master)} + t_{SU,SI(USCI)}, t_{SU,MI(Master)} + t_{VALID,SO(USCI)})$   
For the master parameters  $t_{SU,MI(Master)}$  and  $t_{VALID,MO(Master)}$ , see the SPI parameters of the attached master.
- (2) Specifies the time to drive the next valid data to the SOMI output after the output changing UCLK clock edge. See the timing diagrams in [Figure 5-13](#) and [Figure 5-14](#).
- (3) Specifies how long data on the SOMI output is valid after the output changing UCLK clock edge. See the timing diagrams in [Figure 5-13](#) and [Figure 5-14](#).

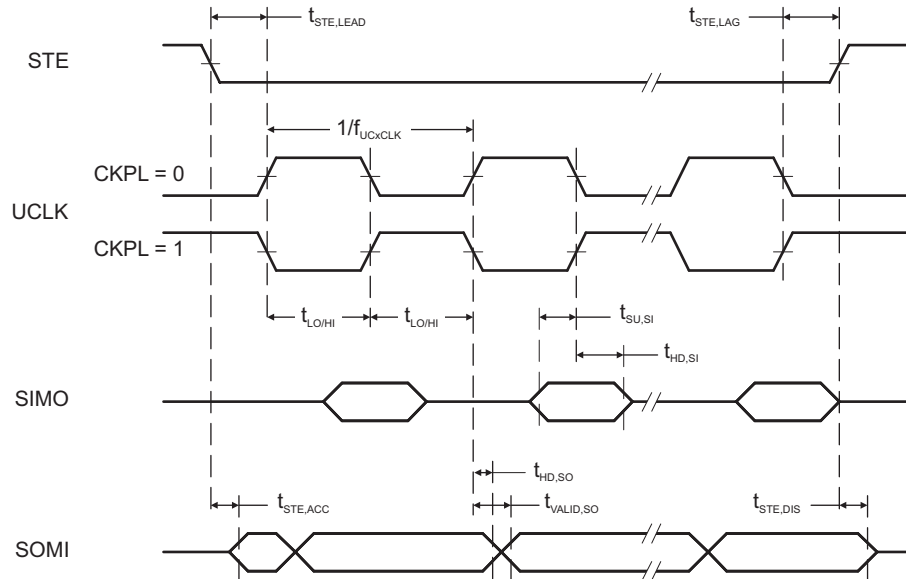

Figure 5-13. SPI Slave Mode, CKPH = 0

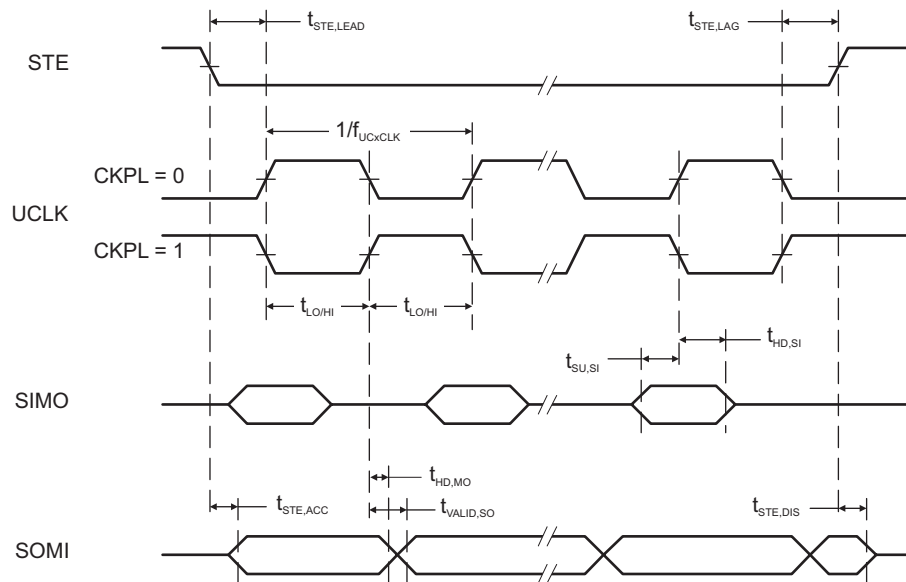

Figure 5-14. SPI Slave Mode, CKPH = 1

### 5.34 USCI (I<sup>2</sup>C Mode)

over recommended ranges of supply voltage and operating free-air temperature (unless otherwise noted) (see [Figure 5-15](#))

PARAMETER		TEST CONDITIONS	V <sub>CC</sub>	MIN	MAX	UNIT
f <sub>USCI</sub>	USCI input clock frequency	Internal: SMCLK or ACLK, External: UCLK Duty cycle = 50% ±10%		f <sub>SYSTEM</sub>		MHz
f <sub>SCL</sub>	SCL clock frequency		2.2 V, 3 V	0	400	kHz
t <sub>HD,STA</sub>	Hold time (repeated) START	f <sub>SCL</sub> ≤ 100 kHz f <sub>SCL</sub> > 100 kHz	2.2 V, 3 V	4.0 0.6		μs
t <sub>SU,STA</sub>	Setup time for a repeated START	f <sub>SCL</sub> ≤ 100 kHz f <sub>SCL</sub> > 100 kHz	2.2 V, 3 V	4.7 0.6		μs
t <sub>HD,DAT</sub>	Data hold time		2.2 V, 3 V	0		ns
t <sub>SU,DAT</sub>	Data setup time		2.2 V, 3 V	250		ns
t <sub>SU,STO</sub>	Setup time for STOP	f <sub>SCL</sub> ≤ 100 kHz f <sub>SCL</sub> > 100 kHz	2.2 V, 3 V	4.0 0.6		μs
t <sub>SP</sub>	Pulse duration of spikes suppressed by input filter		2.2 V 3 V	50 50	600 600	ns

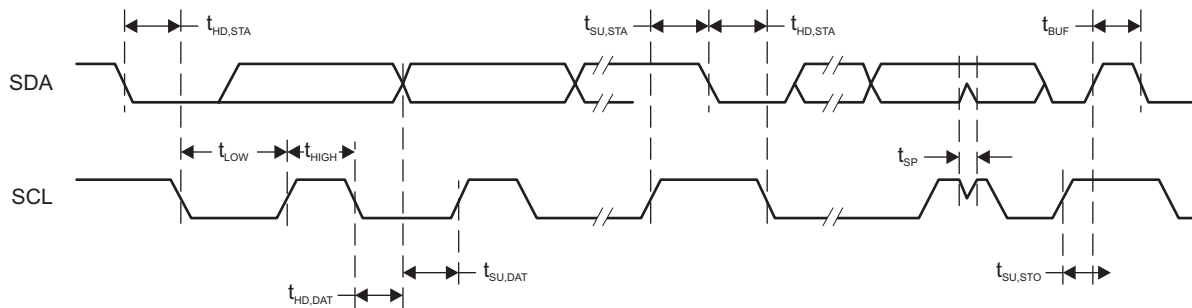

Figure 5-15. I<sup>2</sup>C Mode Timing

### 5.35 LCD\_B Operating Characteristics

over operating free-air temperature range (unless otherwise noted)

PARAMETER	CONDITIONS	MIN	TYP	MAX	UNIT		
$V_{CC,LCD\_B,CP}$ en,3.6	Supply voltage range, charge pump enabled, $V_{LCD} \leq 3.6$ V	LCDPEN = 1, $0000 < VLCDx \leq 1111$ (charge pump enabled, $V_{LCD} \leq 3.6$ V)		2.2	3.6	V	
$V_{CC,LCD\_B,CP}$ en,3.3	Supply voltage range, charge pump enabled, $V_{LCD} \leq 3.3$ V	LCDPEN = 1, $0000 < VLCDx \leq 1100$ (charge pump enabled, $V_{LCD} \leq 3.3$ V)		2.0	3.6	V	
$V_{CC,LCD\_B,int. bias}$	Supply voltage range, internal biasing, charge pump disabled	LCDPEN = 0, VLCDEXT = 0		2.4	3.6	V	
$V_{CC,LCD\_B,ext. bias}$	Supply voltage range, external biasing, charge pump disabled	LCDPEN = 0, VLCDEXT = 0		2.4	3.6	V	
$V_{CC,LCD\_B,VLCDEXT}$	Supply voltage range, external LCD voltage, internal or external biasing, charge pump disabled	LCDPEN = 0, VLCDEXT = 1		2.0	3.6	V	
$V_{LCDCAP/R33}$	External LCD voltage at LCDCAP/R33, internal or external biasing, charge pump disabled	LCDPEN = 0, VLCDEXT = 1		2.4	3.6	V	
$C_{LCDCAP}$	Capacitor on LCDCAP when charge pump enabled	LCDPEN = 1, $VLCDx > 0000$ (charge pump enabled)		4.7	10	$\mu$ F	
$f_{Frame}$	LCD frame frequency range	$f_{LCD} = 2 \times mux \times f_{FRAME}$ with mux = 1 (static), 2, 3, 4		0	100	Hz	
$f_{ACLK,in}$	ACLK input frequency range			30	32	40	kHz
$C_{Panel}$	Panel capacitance	100-Hz frame frequency			10000	pF	
$V_{R33}$	Analog input voltage at R33	LCDPEN = 0, VLCDEXT = 1		2.4	$V_{CC} + 0.2$	V	
$V_{R23,1/3bias}$	Analog input voltage at R23	LCDREXT = 1, LCDEXTBIAS = 1, LCD2B = 0		$V_{R13}$	$V_{R03} + 2/3 \times (V_{R33} - V_{R03})$	$V_{R33}$	V
$V_{R13,1/3bias}$	Analog input voltage at R13 with 1/3 biasing	LCDREXT = 1, LCDEXTBIAS = 1, LCD2B = 0		$V_{R03}$	$V_{R03} + 1/3 \times (V_{R33} - V_{R03})$	$V_{R23}$	V
$V_{R13,1/2bias}$	Analog input voltage at R13 with 1/2 biasing	LCDREXT = 1, LCDEXTBIAS = 1, LCD2B = 1		$V_{R03}$	$V_{R03} + 1/2 \times (V_{R33} - V_{R03})$	$V_{R33}$	V
$V_{R03}$	Analog input voltage at R03	R0EXT = 1		$V_{SS}$			V
$V_{LCD} - V_{R03}$	Voltage difference between $V_{LCD}$ and R03	LCDPEN = 0, R0EXT = 1		2.4	$V_{CC} + 0.2$		V
$V_{LCDREF/R13}$	External LCD reference voltage applied at LCDREF/R13	VLCDFREFx = 01		0.8	1.2	1.5	V

### 5.36 LCD\_B Electrical Characteristics

over operating free-air temperature range (unless otherwise noted)

PARAMETER		TEST CONDITIONS	V <sub>CC</sub>	MIN	TYP	MAX	UNIT
V <sub>LCD</sub>	LCD voltage	VLCDx = 0000, VLCDxEXT = 0	2.4 V to 3.6 V	V <sub>CC</sub>			V
		LCDCPEN = 1, VLCDx = 0001	2 V to 3.6 V	2.59			
		LCDCPEN = 1, VLCDx = 0010	2 V to 3.6 V	2.66			
		LCDCPEN = 1, VLCDx = 0011	2 V to 3.6 V	2.72			
		LCDCPEN = 1, VLCDx = 0100	2 V to 3.6 V	2.79			
		LCDCPEN = 1, VLCDx = 0101	2 V to 3.6 V	2.85			
		LCDCPEN = 1, VLCDx = 0110	2 V to 3.6 V	2.92			
		LCDCPEN = 1, VLCDx = 0111	2 V to 3.6 V	2.98			
		LCDCPEN = 1, VLCDx = 1000	2 V to 3.6 V	3.05			
		LCDCPEN = 1, VLCDx = 1001	2 V to 3.6 V	3.10			
		LCDCPEN = 1, VLCDx = 1010	2 V to 3.6 V	3.17			
		LCDCPEN = 1, VLCDx = 1011	2 V to 3.6 V	3.24			
		LCDCPEN = 1, VLCDx = 1100	2 V to 3.6 V	3.30			
		LCDCPEN = 1, VLCDx = 1101	2.2 V to 3.6 V	3.36			
		LCDCPEN = 1, VLCDx = 1110	2.2 V to 3.6 V	3.42			
LCDCPEN = 1, VLCDx = 1111	2.2 V to 3.6 V	3.48		3.6			
I <sub>CC,Peak,CP</sub>	Peak supply currents due to charge pump activities	LCDCPEN = 1, VLCDx = 1111	2.2 V	400			μA
t <sub>LCD,CP,on</sub>	Time to charge C <sub>LCD</sub> when discharged	C <sub>LCD</sub> = 4.7 μF, LCDCPEN = 0→1, VLCDx = 1111	2.2 V	100	500		ms
I <sub>CP,Load</sub>	Maximum charge pump load current	LCDCPEN = 1, VLCDx = 1111	2.2 V	50			μA
R <sub>LCD,Seg</sub>	LCD driver output impedance, segment lines	LCDCPEN = 1, VLCDx = 1000, I <sub>LOAD</sub> = ±10 μA	2.2 V			10	kΩ
R <sub>LCD,COM</sub>	LCD driver output impedance, common lines	LCDCPEN = 1, VLCDx = 1000, I <sub>LOAD</sub> = ±10 μA	2.2 V			10	kΩ

### 5.37 12-Bit ADC, Power Supply and Input Range Conditions

over recommended ranges of supply voltage and operating free-air temperature (unless otherwise noted)<sup>(1)</sup>

PARAMETER		TEST CONDITIONS	V <sub>CC</sub>	MIN	TYP	MAX	UNIT
AV <sub>CC</sub>	Analog supply voltage	AVCC and DVCC are connected together, AVSS and DVSS are connected together, V(AVSS) = V(DVSS) = 0 V		2.2		3.6	V
V <sub>(Ax)</sub>	Analog input voltage range <sup>(2)</sup>	All ADC12 analog input pins Ax		0		AV <sub>CC</sub>	V
I <sub>ADC12_A</sub>	Operating supply current into AVCC terminal <sup>(3)</sup>	f <sub>ADC12CLK</sub> = 5.0 MHz <sup>(4)</sup>	2.2 V		150	200	μA
			3 V		150	250	
C <sub>I</sub>	Input capacitance	Only one terminal Ax can be selected at one time	2.2 V		20	25	pF
R <sub>I</sub>	Input MUX ON resistance	0 V ≤ VIN ≤ V(AVCC)		10	200	1900	Ω

(1) The leakage current is specified by the digital I/O input leakage.

(2) The analog input voltage range must be within the selected reference voltage range V<sub>R+</sub> to V<sub>R-</sub> for valid conversion results. If the reference voltage is supplied by an external source or if the internal voltage is used and REFOUT = 1, then decoupling capacitors are required. See Section 5.43 and Section 5.44.

(3) The internal reference supply current is not included in current consumption parameter I<sub>ADC12</sub>.

(4) ADC12ON = 1, REFON = 0, SHT0 = 0, SHT1 = 0, ADC12DIV = 0

### 5.38 12-Bit ADC, Timing Parameters

over recommended ranges of supply voltage and operating free-air temperature (unless otherwise noted)

PARAMETER	TEST CONDITIONS	V <sub>CC</sub>	MIN	TYP	MAX	UNIT
f <sub>ADC12CLK</sub> ADC conversion clock	For specified performance of ADC12 linearity parameters using an external reference voltage or AV <sub>CC</sub> as reference <sup>(1)</sup>	2.2 V, 3 V	0.45	4.8	5.0	MHz
	For specified performance of ADC12 linearity parameters using the internal reference <sup>(2)</sup>		0.45	2.4	4.0	
	For specified performance of ADC12 linearity parameters using the internal reference <sup>(3)</sup>		0.45	2.4	2.7	
f <sub>ADC12OSC</sub> Internal ADC12 oscillator <sup>(4)</sup>	ADC12DIV = 0, f <sub>ADC12CLK</sub> = f <sub>ADC12OSC</sub>	2.2 V, 3 V	4.2	4.8	5.4	MHz
t <sub>CONVERT</sub> Conversion time	REFON = 0, Internal oscillator, ADC12OSC used for ADC conversion clock	2.2 V, 3 V	2.4		3.1	μs
	External f <sub>ADC12CLK</sub> from ACLK, MCLK or SMCLK, ADC12SSEL ≠ 0		13 × 1 / f <sub>ADC12CLK</sub>			
t <sub>Sample</sub> Sampling time	R <sub>S</sub> = 400 Ω, R <sub>I</sub> = 200 Ω, C <sub>I</sub> = 20 pF, τ = [R <sub>S</sub> + R <sub>I</sub> ] × C <sub>I</sub> <sup>(5)</sup>	2.2 V, 3 V	1000			ns

- (1) REFOUT = 0, external reference voltage: SREF2 = 0, SREF1 = 1, SREF0 = 0. AV<sub>CC</sub> as reference voltage: SREF2 = 0, SREF1 = 0, SREF0 = 0. The specified performance of the ADC12 linearity is ensured when using the ADC12OSC. For other clock sources, the specified performance of the ADC12 linearity is ensured with f<sub>ADC12CLK</sub> maximum of 5.0 MHz.
- (2) SREF2 = 0, SREF1 = 1, SREF0 = 0, ADC12SR = 0, REFOUT = 1
- (3) SREF2 = 0, SREF1 = 1, SREF0 = 0, ADC12SR = 0, REFOUT = 0. The specified performance of the ADC12 linearity is ensured when using the ADC12OSC divided by 2.
- (4) The ADC12OSC is sourced directly from MODOSC inside the UCS.
- (5) Approximately 10 Tau (τ) are needed to get an error of less than ±0.5 LSB:  
t<sub>Sample</sub> = ln(2<sup>n+1</sup>) × (R<sub>S</sub> + R<sub>I</sub>) × C<sub>I</sub> + 800 ns, where n = ADC resolution = 12, R<sub>S</sub> = external source resistance

### 5.39 12-Bit ADC, Linearity Parameters Using an External Reference Voltage

over recommended ranges of supply voltage and operating free-air temperature (unless otherwise noted)

PARAMETER	TEST CONDITIONS	V <sub>CC</sub>	MIN	TYP	MAX	UNIT
E <sub>I</sub> Integral linearity error <sup>(1)</sup>	1.4 V ≤ dVREF ≤ 1.6 V <sup>(2)</sup>	2.2 V, 3 V			±2	LSB
	1.6 V < dVREF <sup>(2)</sup>				±1.7	
E <sub>D</sub> Differential linearity error <sup>(1)</sup>	See <sup>(2)</sup>	2.2 V, 3 V			±1	LSB
E <sub>O</sub> Offset error <sup>(3)</sup>	dVREF ≤ 2.2 V <sup>(2)</sup>	2.2 V, 3 V			±3    ±5.6	LSB
	dVREF > 2.2 V <sup>(2)</sup>	2.2 V, 3 V			±1.5    ±3.5	
E <sub>G</sub> Gain error <sup>(3)</sup>	See <sup>(2)</sup>	2.2 V, 3 V			±1    ±2.5	LSB
E <sub>T</sub> Total unadjusted error	dVREF ≤ 2.2 V <sup>(2)</sup>	2.2 V, 3 V			±3.5    ±7.1	LSB
	dVREF > 2.2 V <sup>(2)</sup>	2.2 V, 3 V			±2    ±5	

- (1) Parameters are derived using the histogram method.
- (2) The external reference voltage is selected by: SREF2 = 0 or 1, SREF1 = 1, SREF0 = 0. dVREF = V<sub>R+</sub> – V<sub>R-</sub>. V<sub>R+</sub> < AV<sub>CC</sub>. V<sub>R-</sub> > AV<sub>SS</sub>. Unless otherwise mentioned dVREF > 1.5 V. Impedance of the external reference voltage R < 100 Ω and two decoupling capacitors, 10 μF and 100 nF, should be connected to VREF to decouple the dynamic current. Also see the [MSP430F5xx and MSP430F6xx Family User's Guide](#).
- (3) Parameters are derived using a best fit curve.

## 5.40 12-Bit ADC, Linearity Parameters Using $V_{CC}$ as Reference Voltage

over recommended ranges of supply voltage and operating free-air temperature (unless otherwise noted)

PARAMETER		TEST CONDITIONS	$V_{CC}$	MIN	TYP	MAX	UNIT
$E_I$	Integral linearity error <sup>(1)</sup>	See <sup>(2)</sup>	2.2 V, 3 V			±2.0	LSB
$E_D$	Differential linearity error <sup>(1)</sup>	See <sup>(2)</sup>	2.2 V, 3 V			±1	LSB
$E_O$	Offset error <sup>(3)</sup>	See <sup>(2)</sup>	2.2 V, 3 V		±1	±2	LSB
$E_G$	Gain error <sup>(3)</sup>	See <sup>(2)</sup>	2.2 V, 3 V		±2	±4	LSB
$E_T$	Total unadjusted error	See <sup>(2)</sup>	2.2 V, 3 V		±2	±5	LSB

- (1) Parameters are derived using the histogram method.  
(2)  $V_{CC}$  as reference voltage is selected by: SREF2 = 0, SREF1 = 0, SREF0 = 0.  
(3) Parameters are derived using a best fit curve.

## 5.41 12-Bit ADC, Linearity Parameters Using the Internal Reference Voltage

over recommended ranges of supply voltage and operating free-air temperature (unless otherwise noted)

PARAMETER		TEST CONDITIONS <sup>(1)</sup>		$V_{CC}$	MIN	TYP	MAX	UNIT
$E_I$	Integral linearity error <sup>(2)</sup>	ADC12SR = 0, REFOUT = 1	$f_{ADC12CLK} \leq 4.0$ MHz	2.2 V, 3 V			±2.0	LSB
		ADC12SR = 0, REFOUT = 0	$f_{ADC12CLK} \leq 2.7$ MHz				±2.5	
$E_D$	Differential linearity error <sup>(2)</sup>	ADC12SR = 0, REFOUT = 1	$f_{ADC12CLK} \leq 4.0$ MHz	2.2 V, 3 V		-1	+1.5	LSB
		ADC12SR = 0, REFOUT = 1	$f_{ADC12CLK} \leq 2.7$ MHz				±1	
		ADC12SR = 0, REFOUT = 0	$f_{ADC12CLK} \leq 2.7$ MHz				-1	
$E_O$	Offset error <sup>(3)</sup>	ADC12SR = 0, REFOUT = 1	$f_{ADC12CLK} \leq 4.0$ MHz	2.2 V, 3 V			±2	LSB
		ADC12SR = 0, REFOUT = 0	$f_{ADC12CLK} \leq 2.7$ MHz				±2	
$E_G$	Gain error <sup>(3)</sup>	ADC12SR = 0, REFOUT = 1	$f_{ADC12CLK} \leq 4.0$ MHz	2.2 V, 3 V			±1	LSB
		ADC12SR = 0, REFOUT = 0	$f_{ADC12CLK} \leq 2.7$ MHz				±1% <sup>(4)</sup>	
$E_T$	Total unadjusted error	ADC12SR = 0, REFOUT = 1	$f_{ADC12CLK} \leq 4.0$ MHz	2.2 V, 3 V			±2	LSB
		ADC12SR = 0, REFOUT = 0	$f_{ADC12CLK} \leq 2.7$ MHz				±1% <sup>(4)</sup>	

- (1) The external reference voltage is selected by: SREF2 = 0, SREF1 = 0, SREF0 = 1.  $dV_{REF} = V_{R+} - V_{R-}$ .  
(2) Parameters are derived using the histogram method.  
(3) Parameters are derived using a best fit curve.  
(4) The gain error and the total unadjusted error are dominated by the accuracy of the integrated reference module absolute accuracy. In this mode, the reference voltage used by the ADC12\_A is not available on a pin.

## 5.42 12-Bit ADC, Temperature Sensor and Built-In $V_{MID}$ <sup>(1)</sup>

over recommended ranges of supply voltage and operating free-air temperature (unless otherwise noted)

PARAMETER		TEST CONDITIONS	$V_{CC}$	MIN	TYP	MAX	UNIT
$V_{SENSOR}$	Temperature sensor voltage <sup>(2)</sup> (see Figure 5-16)	ADC12ON = 1, INCH = 0Ah, $T_A = 0^\circ\text{C}$	2.2 V		680		mV
			3 V		680		
$TC_{SENSOR}$	Temperature coefficient of sensor	ADC12ON = 1, INCH = 0Ah	2.2 V, 3V		2.25 <sup>(2)</sup>		mV/°C
$t_{SENSOR(sample)}$	Sample time required if channel 10 is selected <sup>(3)</sup>	ADC12ON = 1, INCH = 0Ah, Error of conversion result $\leq 1$ LSB	2.2 V		30		$\mu\text{s}$
			3 V		30		
$V_{MID}$	$V_{CC}$ divider at channel 11	ADC12ON = 1, INCH = 0Bh, $V_{MID} \approx 0.5 \times V_{AVCC}$	2.2 V	1.06	1.1	1.14	V
			3 V	1.46	1.5	1.54	
$t_{VMID(sample)}$	Sample time required if channel 11 is selected <sup>(4)</sup>	ADC12ON = 1, INCH = 0Bh, Error of conversion result $\leq 1$ LSB	2.2 V, 3 V		1000		ns

- (1) The temperature sensor is provided by the REF module. See the REF module parametric,  $I_{REF+}$ , regarding the current consumption of the temperature sensor.  
(2) The temperature sensor offset can be significant. TI recommends a single-point calibration to minimize the offset error of the built-in temperature sensor. The TLV structure contains calibration values for  $30^\circ\text{C} \pm 3^\circ\text{C}$  and  $85^\circ\text{C} \pm 3^\circ\text{C}$  for each of the available reference voltage levels. The sensor voltage can be computed as  $V_{SENSE} = TC_{SENSOR} \times (\text{Temperature}, ^\circ\text{C}) + V_{SENSOR}$ , where  $TC_{SENSOR}$  and  $V_{SENSOR}$  can be computed from the calibration values for higher accuracy. Also see the [MSP430F5xx and MSP430F6xx Family User's Guide](#).  
(3) The typical equivalent impedance of the sensor is 51 k $\Omega$ . The sample time required includes the sensor-on time  $t_{SENSOR(on)}$ .  
(4) The on-time  $t_{VMID(on)}$  is included in the sampling time  $t_{VMID(sample)}$ ; no additional on time is needed.

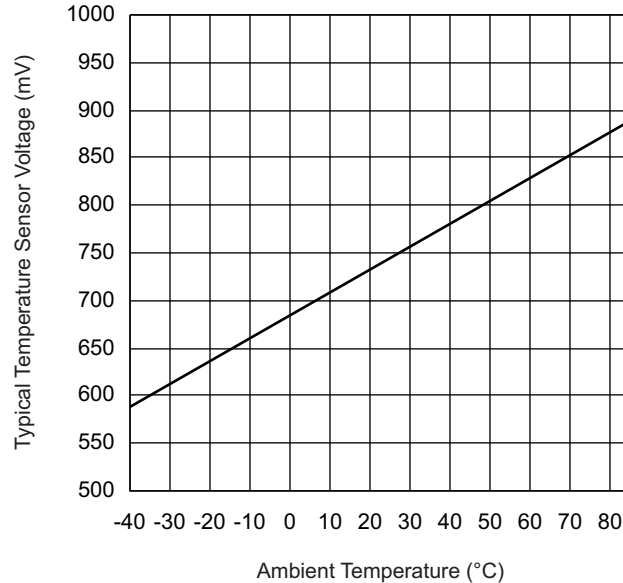

Figure 5-16. Typical Temperature Sensor Voltage

### 5.43 REF, External Reference

over recommended ranges of supply voltage and operating free-air temperature (unless otherwise noted)<sup>(1)</sup>

PARAMETER		TEST CONDITIONS	V <sub>CC</sub>	MIN	MAX	UNIT
V <sub>eREF+</sub>	Positive external reference voltage input	V <sub>eREF+</sub> > V <sub>REF-</sub> - V <sub>eREF-</sub> <sup>(2)</sup>		1.4	AV <sub>CC</sub>	V
V <sub>REF-</sub> - V <sub>eREF-</sub>	Negative external reference voltage input	V <sub>eREF+</sub> > V <sub>REF-</sub> - V <sub>eREF-</sub> <sup>(3)</sup>		0	1.2	V
(V <sub>eREF+</sub> - V <sub>REF-</sub> - V <sub>eREF-</sub> )	Differential external reference voltage input	V <sub>eREF+</sub> > V <sub>REF-</sub> - V <sub>eREF-</sub> <sup>(4)</sup>		1.4	AV <sub>CC</sub>	V
I <sub>VeREF+</sub> , I <sub>VREF- - VeREF-</sub>	Static input current	1.4 V ≤ V <sub>eREF+</sub> ≤ V <sub>AVCC</sub> , V <sub>eREF-</sub> = 0 V, f <sub>ADC12CLK</sub> = 5 MHz, ADC12SHTx = 1h, Conversion rate 200 ksps	2.2 V, 3 V	-26	26	μA
		1.4 V ≤ V <sub>eREF+</sub> ≤ V <sub>AVCC</sub> , V <sub>eREF-</sub> = 0 V, f <sub>ADC12CLK</sub> = 5 MHz, ADC12SHTx = 8h, Conversion rate 20 ksps	2.2 V, 3 V	-1.2	+1.2	
C <sub>VREF+/-</sub>	Capacitance at VREF+ or VREF- terminal <sup>(5)</sup>			10		μF

- (1) The external reference is used during ADC conversion to charge and discharge the capacitance array. The input capacitance, C<sub>i</sub>, is also the dynamic load for an external reference during conversion. The dynamic impedance of the reference supply should follow the recommendations on analog-source impedance to allow the charge to settle for 12-bit accuracy.
- (2) The accuracy limits the minimum positive external reference voltage. Lower reference voltage levels may be applied with reduced accuracy requirements.
- (3) The accuracy limits the maximum negative external reference voltage. Higher reference voltage levels may be applied with reduced accuracy requirements.
- (4) The accuracy limits minimum external differential reference voltage. Lower differential reference voltage levels may be applied with reduced accuracy requirements.
- (5) Two decoupling capacitors, 10 μF and 100 nF, should be connected to VREF to decouple the dynamic current required for an external reference source if it is used for the ADC12\_A. Also see the [MSP430F5xx and MSP430F6xx Family User's Guide](#).

## 5.44 REF, Built-In Reference

over recommended ranges of supply voltage and operating free-air temperature (unless otherwise noted)<sup>(1)</sup>

PARAMETER	TEST CONDITIONS		V <sub>CC</sub>	MIN	TYP	MAX	UNIT
V <sub>REF+</sub> Positive built-in reference voltage output	REFVSEL = {2} for 2.5 V, REFON = REFOUT = 1, I <sub>VREF+</sub> = 0 A		3 V		2.5	±1%	V
	REFVSEL = {1} for 2 V, REFON = REFOUT = 1, I <sub>VREF+</sub> = 0 A		3 V		2.0	±1%	
	REFVSEL = {0} for 1.5 V, REFON = REFOUT = 1, I <sub>VREF+</sub> = 0 A		2.2 V, 3 V		1.5	±1%	
AV <sub>CC(min)</sub> AVCC minimum voltage, Positive built-in reference active	REFVSEL = {0} for 1.5 V				2.2		V
	REFVSEL = {1} for 2 V				2.3		
	REFVSEL = {2} for 2.5 V				2.8		
I <sub>REF+</sub> Operating supply current into AVCC terminal <sup>(2) (3)</sup>	ADC12SR = 1 <sup>(4)</sup> , REFON = 1, REFOUT = 0, REFBURST = 0		3 V		70	100	μA
	ADC12SR = 1 <sup>(4)</sup> , REFON = 1, REFOUT = 1, REFBURST = 0				0.45	0.75	mA
	ADC12SR = 0 <sup>(4)</sup> , REFON = 1, REFOUT = 0, REFBURST = 0				210	310	μA
	ADC12SR = 0 <sup>(4)</sup> , REFON = 1, REFOUT = 1, REFBURST = 0				0.95	1.7	mA
I <sub>L(VREF+)</sub> Load-current regulation, VREF+ terminal <sup>(5)</sup>	REFVSEL = {0, 1, 2}, I <sub>VREF+</sub> = +10 μA or -1000 μA, AV <sub>CC</sub> = AV <sub>CC(min)</sub> for each reference level, REFVSEL = {0, 1, 2}, REFON = REFOUT = 1				1500	2500	μV/mA
C <sub>VREF+</sub> Capacitance at VREF+ terminal	REFON = REFOUT = 1 <sup>(6)</sup> , 0 mA ≤ I <sub>VREF+</sub> ≤ I <sub>VREF+(max)</sub>		2.2 V, 3 V		20	100	pF
TC <sub>REF+</sub> Temperature coefficient of built-in reference <sup>(7)</sup>	I <sub>VREF+</sub> is a constant in the range of 0 mA ≤ I <sub>VREF+</sub> ≤ -1 mA	REFOUT = 0	2.2 V, 3 V		20		ppm/°C
TC <sub>REF+</sub> Temperature coefficient of built-in reference <sup>(7)</sup>	I <sub>VREF+</sub> is a constant in the range of 0 mA ≤ I <sub>VREF+</sub> ≤ -1 mA	REFOUT = 1	2.2 V, 3 V		20	50	ppm/°C
PSRR <sub>DC</sub> Power supply rejection ratio (DC)	AV <sub>CC</sub> = AV <sub>CC(min)</sub> to AV <sub>CC(max)</sub> , T <sub>A</sub> = 25°C, REFVSEL = {0, 1, 2}, REFON = 1, REFOUT = 0 or 1				120	300	μV/V
PSRR <sub>AC</sub> Power supply rejection ratio (AC)	AV <sub>CC</sub> = AV <sub>CC(min)</sub> to AV <sub>CC(max)</sub> , T <sub>A</sub> = 25°C, REFVSEL = {0, 1, 2}, REFON = 1, REFOUT = 0 or 1				1		mV/V
t <sub>SETTLE</sub> Settling time of reference voltage <sup>(8)</sup>	AV <sub>CC</sub> = AV <sub>CC(min)</sub> to AV <sub>CC(max)</sub> , REFVSEL = {0, 1, 2}, REFOUT = 0, REFON = 0 → 1				75		μs
	AV <sub>CC</sub> = AV <sub>CC(min)</sub> to AV <sub>CC(max)</sub> , C <sub>VREF</sub> = C <sub>VREF(max)</sub> , REFVSEL = {0, 1, 2}, REFOUT = 1, REFON = 0 → 1				75		

(1) The reference is supplied to the ADC by the REF module and is buffered locally inside the ADC. The ADC uses two internal buffers, one smaller and one larger for driving the VREF+ terminal. When REFOUT = 1, the reference is available at the VREF+ terminal and is used as the reference for the conversion and uses the larger buffer. When REFOUT = 0, the reference is only used as the reference for the conversion and uses the smaller buffer.

(2) The internal reference current is supplied from the AVCC terminal. Consumption is independent of the ADC12ON control bit, unless a conversion is active. REFOUT = 0 represents the current contribution of the smaller buffer. REFOUT = 1 represents the current contribution of the larger buffer without external load.

(3) The temperature sensor is provided by the REF module. Its current is supplied from the AVCC terminal and is equivalent to I<sub>REF+</sub> with REFON = 1 and REFOUT = 0.

(4) For devices without the ADC12, the parametric with ADC12SR = 0 are applicable.

(5) Contribution only due to the reference and buffer including package. This does not include resistance due to PCB trace or other causes.

(6) Two decoupling capacitors, 10 μF and 100 nF, should be connected to VREF to decouple the dynamic current required for an external reference source if it is used for the ADC12\_A. Also see the [MSP430F5xx and MSP430F6xx Family User's Guide](#).

(7) Calculated using the box method: (MAX(-40°C to 85°C) – MIN(-40°C to 85°C)) / (MIN(-40°C to 85°C)/(85°C – (-40°C))).

(8) The condition is that the error in a conversion started after t<sub>REFON</sub> is less than ±0.5 LSB. The settling time depends on the external capacitive load when REFOUT = 1.

## 5.45 12-Bit DAC, Supply Specifications

over recommended ranges of supply voltage and operating free-air temperature (unless otherwise noted)

PARAMETER		TEST CONDITIONS	V <sub>CC</sub>	MIN	TYP	MAX	UNIT
AV <sub>CC</sub>	Analog supply voltage	AV <sub>CC</sub> = DV <sub>CC</sub> , AV <sub>SS</sub> = DV <sub>SS</sub> = 0 V		2.20		3.60	V
I <sub>DD</sub>	Supply current, single DAC channel <sup>(1)(2)</sup>	DAC12AMPx = 2, DAC12IR = 0, DAC12IOG = 1 DAC12_xDAT = 0800h V <sub>REF+</sub> = V <sub>REF+</sub> = 1.5 V	3 V		65	110	μA
		DAC12AMPx = 2, DAC12IR = 1, DAC12_xDAT = 0800h, V <sub>REF+</sub> = V <sub>REF+</sub> = AV <sub>CC</sub>			65	110	
		DAC12AMPx = 5, DAC12IR = 1, DAC12_xDAT = 0800h, V <sub>REF+</sub> = V <sub>REF+</sub> = AV <sub>CC</sub>	2.2 V, 3 V		250	300	
		DAC12AMPx = 7, DAC12IR = 1, DAC12_xDAT = 0800h, V <sub>REF+</sub> = V <sub>REF+</sub> = AV <sub>CC</sub>			750	1000	
PSRR	Power supply rejection ratio <sup>(3)(4)</sup>	DAC12_xDAT = 800h, V <sub>REF+</sub> = 1.5 V, ΔAV <sub>CC</sub> = 100 mV	2.2 V		70		dB
		DAC12_xDAT = 800h, V <sub>REF+</sub> = 1.5 V or 2.5 V, ΔAV <sub>CC</sub> = 100 mV	3 V		70		

- (1) No load at the output pin, DAC12\_0 or DAC12\_1, assuming that the control bits for the shared pins are set properly.
- (2) Current into reference terminals not included. If DAC12IR = 1 current flows through the input divider; see Reference Input specifications.
- (3) PSRR = 20 log (ΔAV<sub>CC</sub> / ΔV<sub>DAC12\_xOUT</sub>)
- (4) The internal reference is not used.

## 5.46 12-Bit DAC, Linearity Specifications

See [Figure 5-17](#), over recommended ranges of supply voltage and operating free-air temperature (unless otherwise noted)

PARAMETER	TEST CONDITIONS	V <sub>CC</sub>	MIN	TYP	MAX	UNIT
Resolution	12-bit monotonic		12			bits
INL	Integral nonlinearity <sup>(1)</sup>	V <sub>REF+</sub> = 1.5 V, DAC12AMPx = 7, DAC12IR = 1	2.2 V	±2	±4	LSB
		V <sub>REF+</sub> = 2.5 V, DAC12AMPx = 7, DAC12IR = 1	3 V	±2	±4	
DNL	Differential nonlinearity <sup>(1)</sup>	V <sub>REF+</sub> = 1.5 V, DAC12AMPx = 7, DAC12IR = 1	2.2 V	±0.4	±1	LSB
		V <sub>REF+</sub> = 2.5 V, DAC12AMPx = 7, DAC12IR = 1	3 V	±0.4	±1	
E <sub>O</sub>	Without calibration <sup>(1) (2)</sup>	V <sub>REF+</sub> = 1.5 V, DAC12AMPx = 7, DAC12IR = 1	2.2 V		±21	mV
		V <sub>REF+</sub> = 2.5 V, DAC12AMPx = 7, DAC12IR = 1	3 V		±21	
	With calibration <sup>(1) (2)</sup>	V <sub>REF+</sub> = 1.5 V, DAC12AMPx = 7, DAC12IR = 1	2.2 V		±1.5	
		V <sub>REF+</sub> = 2.5 V, DAC12AMPx = 7, DAC12IR = 1	3 V		±1.5	
d <sub>E(O)/dT</sub>	Offset error temperature coefficient <sup>(1)</sup>	With calibration	2.2 V, 3 V	±10		µV/°C
E <sub>G</sub>	Gain error	V <sub>REF+</sub> = 1.5 V	2.2 V		±2.5	%FSR
		V <sub>REF+</sub> = 2.5 V	3 V		±2.5	
d <sub>E(G)/dT</sub>	Gain temperature coefficient <sup>(1)</sup>		2.2 V, 3 V	10		ppm of FSR/°C
t <sub>Offset_Cal</sub>	Time for offset calibration <sup>(3)</sup>	DAC12AMPx = 2	2.2 V, 3 V		165	ms
		DAC12AMPx = 3, 5			66	
		DAC12AMPx = 4, 6, 7			16.5	

- (1) Parameters calculated from the best-fit curve from 0x0F to 0xFF. The best-fit curve method is used to deliver coefficients "a" and "b" of the first-order equation:  $y = a + bx$ .  $V_{DAC12\_xOUT} = E_O + (1 + E_G) \times (V_{REF+}/4095) \times DAC12\_xDAT$ , DAC12IR = 1.
- (2) The offset calibration works on the output operational amplifier. Offset Calibration is triggered setting bit DAC12CALON
- (3) The offset calibration can be done if DAC12AMPx = {2, 3, 4, 5, 6, 7}. The output operational amplifier is switched off with DAC12AMPx = {0, 1}. TI recommends configuring the DAC12 module before initiating calibration. Port activity during calibration may affect accuracy and is not recommended.

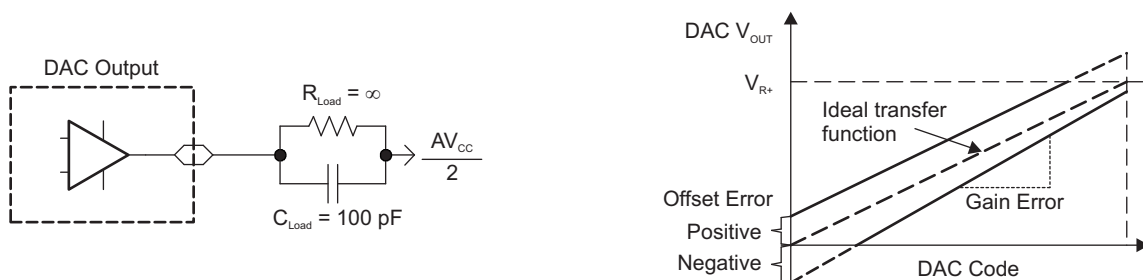

Figure 5-17. Linearity Test Load Conditions and Gain/Offset Definition

### 5.47 12-Bit DAC, Output Specifications

over recommended ranges of supply voltage and operating free-air temperature (unless otherwise noted)

PARAMETER	TEST CONDITIONS	V <sub>CC</sub>	MIN	TYP	MAX	UNIT
V <sub>O</sub> Output voltage range <sup>(1)</sup> (see Figure 5-18)	No load, V <sub>REF+</sub> = AV <sub>CC</sub> , DAC12_xDAT = 0h, DAC12IR = 1, DAC12AMPx = 7	2.2 V, 3 V	0		0.005	V
	No load, V <sub>REF+</sub> = AV <sub>CC</sub> , DAC12_xDAT = 0FFFh, DAC12IR = 1, DAC12AMPx = 7		AV <sub>CC</sub> - 0.05		AV <sub>CC</sub>	
	R <sub>Load</sub> = 3 kΩ, V <sub>REF+</sub> = AV <sub>CC</sub> , DAC12_xDAT = 0h, DAC12IR = 1, DAC12AMPx = 7		0		0.1	
	R <sub>Load</sub> = 3 kΩ, V <sub>REF+</sub> = AV <sub>CC</sub> , DAC12_xDAT = 0FFFh, DAC12IR = 1, DAC12AMPx = 7		AV <sub>CC</sub> - 0.13		AV <sub>CC</sub>	
C <sub>L(DAC12)</sub> Maximum DAC12 load capacitance		2.2 V, 3 V			100	pF
I <sub>L(DAC12)</sub> Maximum DAC12 load current	DAC12AMPx = 2, DAC12_xDAT = 0FFFh, V <sub>O/P(DAC12)</sub> > AV <sub>CC</sub> - 0.3	2.2 V, 3 V	-1			mA
	DAC12AMPx = 2, DAC12_xDAT = 0h, V <sub>O/P(DAC12)</sub> < 0.3 V				1	
R <sub>O/P(DAC12)</sub> Output resistance (see Figure 5-18)	R <sub>Load</sub> = 3 kΩ, V <sub>O/P(DAC12)</sub> < 0.3 V, DAC12AMPx = 2, DAC12_xDAT = 0h	2.2 V, 3 V		150	250	Ω
	R <sub>Load</sub> = 3 kΩ, V <sub>O/P(DAC12)</sub> > AV <sub>CC</sub> - 0.3 V, DAC12_xDAT = 0FFFh			150	250	
	R <sub>Load</sub> = 3 kΩ, 0.3 V ≤ V <sub>O/P(DAC12)</sub> ≤ AV <sub>CC</sub> - 0.3 V					

(1) Data is valid after the offset calibration of the output amplifier.

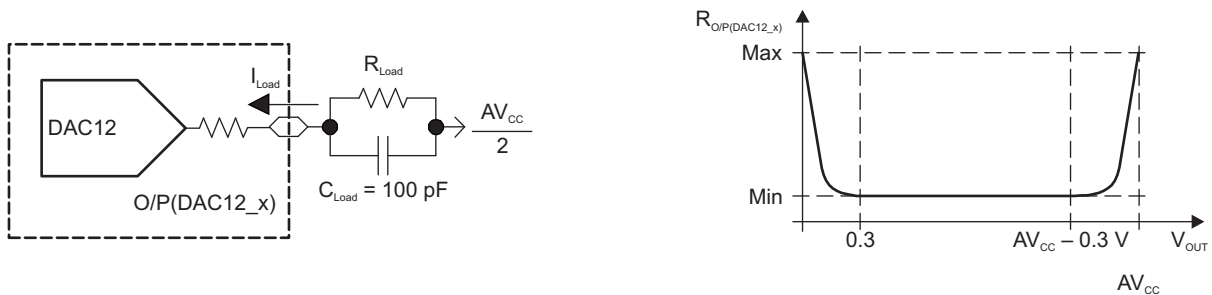

Figure 5-18. DAC12\_x Output Resistance Tests

### 5.48 12-Bit DAC, Reference Input Specifications

over recommended ranges of supply voltage and operating free-air temperature (unless otherwise noted)

PARAMETER	TEST CONDITIONS	V <sub>CC</sub>	MIN	TYP	MAX	UNIT
V <sub>REF+</sub> Reference input voltage range	DAC12IR = 0 <sup>(1)</sup> (2)	2.2 V, 3 V		AV <sub>CC</sub> /3	AV <sub>CC</sub> + 0.2	V
	DAC12IR = 1 <sup>(3)</sup> (4)			AV <sub>CC</sub>	AV <sub>CC</sub> + 0.2	
R <sub>i(VREF+)</sub> , R <sub>i(VeREF+)</sub> Reference input resistance	DAC12_0 IR = DAC12_1 IR = 0	2.2 V, 3 V		20		MΩ
	DAC12_0 IR = 1, DAC12_1 IR = 0			52		kΩ
	DAC12_0 IR = 0, DAC12_1 IR = 1			52		
	DAC12_0 IR = DAC12_1 IR = 1, DAC12_0 SREFx = DAC12_1 SREFx <sup>(5)</sup>			26		

- (1) For a full-scale output, the reference input voltage can be as high as 1/3 of the maximum output voltage swing (AV<sub>CC</sub>).
- (2) The maximum voltage applied at reference input voltage terminal VeREF+ = [AV<sub>CC</sub> - V<sub>E(O)</sub>] / [3 × (1 + E<sub>G</sub>)].
- (3) For a full-scale output, the reference input voltage can be as high as the maximum output voltage swing (AV<sub>CC</sub>).
- (4) The maximum voltage applied at reference input voltage terminal VeREF+ = [AV<sub>CC</sub> - V<sub>E(O)</sub>] / (1 + E<sub>G</sub>).
- (5) When DAC12IR = 1 and DAC12SREFx = 0 or 1 for both channels, the reference input resistive dividers for each DAC are in parallel reducing the reference input resistance.

### 5.49 12-Bit DAC, Dynamic Specifications

V<sub>REF</sub> = V<sub>CC</sub>, DAC12IR = 1 (see Figure 5-19 and Figure 5-20), over recommended ranges of supply voltage and operating free-air temperature (unless otherwise noted)

PARAMETER	TEST CONDITIONS	V <sub>CC</sub>	MIN	TYP	MAX	UNIT	
t <sub>ON</sub> DAC12 on time	DAC12_xDAT = 800h, Error <sub>V(O)</sub> < ±0.5 LSB <sup>(1)</sup> (see Figure 5-19)	2.2 V, 3 V	DAC12AMPx = 0 → {2, 3, 4}		60	120	μs
			DAC12AMPx = 0 → {5, 6}		15	30	
			DAC12AMPx = 0 → 7		6	12	
t <sub>S(FS)</sub> Settling time, full scale	DAC12_xDAT = 80h → F7Fh → 80h	2.2 V, 3 V	DAC12AMPx = 2		100	200	μs
			DAC12AMPx = 3, 5		40	80	
			DAC12AMPx = 4, 6, 7		15	30	
t <sub>S(C-C)</sub> Settling time, code to code	DAC12_xDAT = 3F8h → 408h → 3F8h, BF8h → C08h → BF8h	2.2 V, 3 V	DAC12AMPx = 2		5		μs
			DAC12AMPx = 3, 5		2		
			DAC12AMPx = 4, 6, 7		1		
SR Slew rate	DAC12_xDAT = 80h → F7Fh → 80h <sup>(2)</sup>	2.2 V, 3 V	DAC12AMPx = 2		0.05	0.35	V/μs
			DAC12AMPx = 3, 5		0.35	1.10	
			DAC12AMPx = 4, 6, 7		1.50	5.20	
Glitch energy	DAC12_xDAT = 800h → 7FFh → 800h	2.2 V, 3 V	DAC12AMPx = 7		35	nV-s	

- (1) R<sub>Load</sub> and C<sub>Load</sub> connected to AV<sub>SS</sub> (not AV<sub>CC</sub>/2) in Figure 5-19.
- (2) Slew rate applies to output voltage steps ≥ 200 mV.

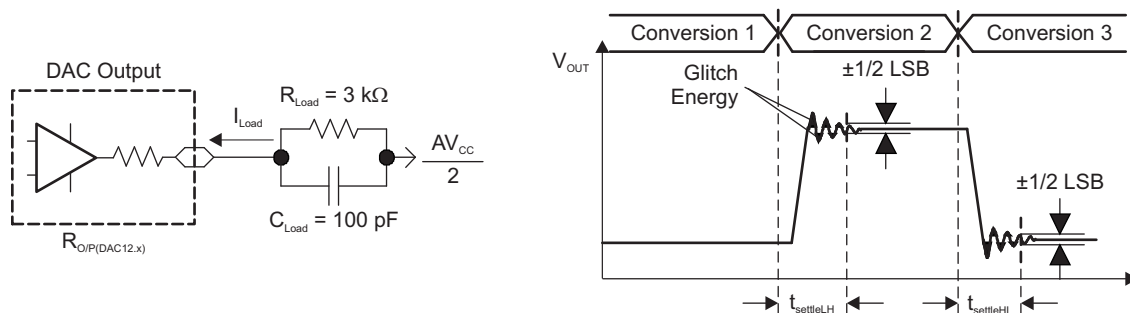

Figure 5-19. Settling Time and Glitch Energy Testing

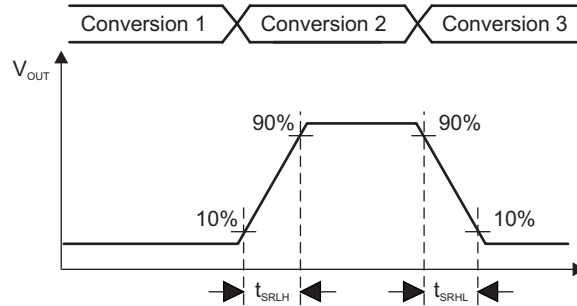

Figure 5-20. Slew Rate Testing

### 5.50 12-Bit DAC, Dynamic Specifications (Continued)

over recommended ranges of supply voltage and operating free-air temperature (unless otherwise noted)

PARAMETER	TEST CONDITIONS	V <sub>CC</sub>	MIN	TYP	MAX	UNIT
BW <sub>-3dB</sub> 3-dB bandwidth, V <sub>DC</sub> = 1.5 V, V <sub>AC</sub> = 0.1 V <sub>PP</sub> (see Figure 5-21)	DAC12AMPx = {2, 3, 4}, DAC12SREFx = 2, DAC12IR = 1, DAC12_xDAT = 800h T <sub>A</sub> = 25°C	2.2 V, 3 V	40			kHz
	DAC12AMPx = {5, 6}, DAC12SREFx = 2, DAC12IR = 1, DAC12_xDAT = 800h T <sub>A</sub> = 25°C		180			
	DAC12AMPx = 7, DAC12SREFx = 2, DAC12IR = 1, DAC12_xDAT = 800h T <sub>A</sub> = 25°C		550			
Channel-to-channel crosstalk <sup>(1)</sup> (see Figure 5-22)	DAC12_0DAT = 800h, No load, DAC12_1DAT = 80h ↔ F7Fh, R <sub>Load</sub> = 3 kΩ, f <sub>DAC12_1OUT</sub> = 10 kHz at 50/50 duty cycle, T <sub>A</sub> = 25°C	2.2 V, 3 V		-80		dB
	DAC12_0DAT = 80h ↔ F7Fh, R <sub>Load</sub> = 3 kΩ, DAC12_1DAT = 800h, No load, f <sub>DAC12_0OUT</sub> = 10 kHz at 50/50 duty cycle, T <sub>A</sub> = 25°C			-80		

(1) R<sub>Load</sub> = 3 kΩ, C<sub>Load</sub> = 100 pF

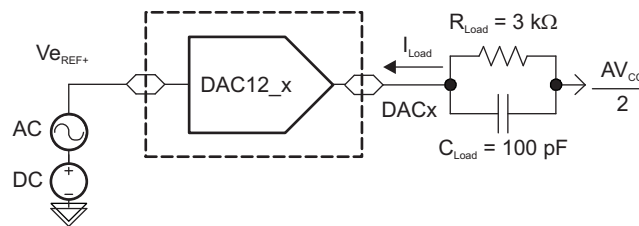

Figure 5-21. Test Conditions for 3-dB Bandwidth Specification

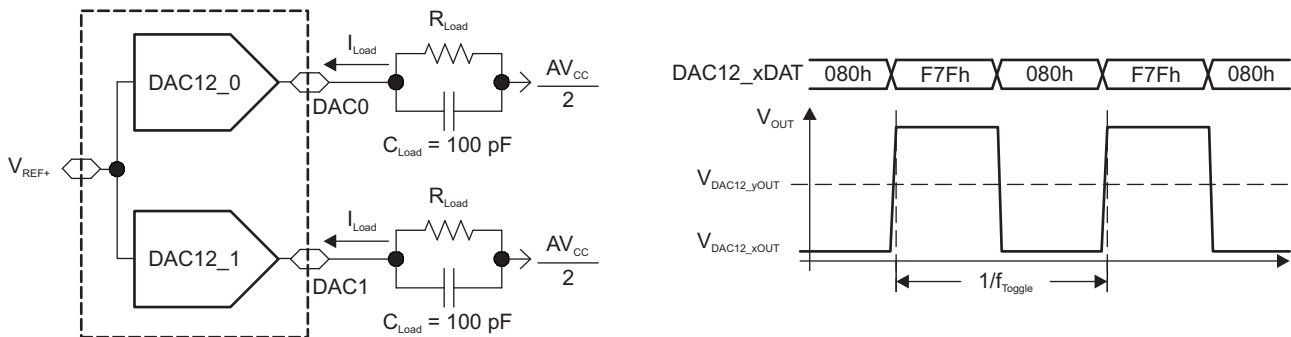

Figure 5-22. Crosstalk Test Conditions

## 5.51 Comparator\_B

over recommended ranges of supply voltage and operating free-air temperature (unless otherwise noted)

PARAMETER	TEST CONDITIONS	V <sub>CC</sub>	MIN	TYP	MAX	UNIT	
V <sub>CC</sub>	Supply voltage		1.8		3.6	V	
I <sub>AVCC_COMP</sub>	Comparator operating supply current into AVCC terminal, Excludes reference resistor ladder	CBPWRMD = 00	1.8 V		40	μA	
			2.2 V		30		
			3 V		40		
		CBPWRMD = 01	2.2 V, 3 V		10		30
		CBPWRMD = 10	2.2 V, 3 V		0.1		0.5
I <sub>AVCC_REF</sub>	Quiescent current of local reference voltage amplifier into AVCC terminal	CBREFACC = 1, CBREFLx = 01			22	μA	
V <sub>IC</sub>	Common mode input range		0	V <sub>CC</sub> – 1		V	
V <sub>OFFSET</sub>	Input offset voltage	CBPWRMD = 00			±20	mV	
		CBPWRMD = 01 or 10			±10		
C <sub>IN</sub>	Input capacitance			5		pF	
R <sub>SIN</sub>	Series input resistance	On (switch closed)		3	4	kΩ	
		Off (switch open)	50			MΩ	
t <sub>PD</sub>	Propagation delay, response time	CBPWRMD = 00, CBF = 0			450	ns	
		CBPWRMD = 01, CBF = 0			600		
		CBPWRMD = 10, CBF = 0			50	μs	
t <sub>PD,filter</sub>	Propagation delay with filter active	CBPWRMD = 00, CBON = 1, CBF = 1, CBFDLY = 00	0.35	0.6	1.0	μs	
		CBPWRMD = 00, CBON = 1, CBF = 1, CBFDLY = 01	0.6	1.0	1.8		
		CBPWRMD = 00, CBON = 1, CBF = 1, CBFDLY = 10	1.0	1.8	3.4		
		CBPWRMD = 00, CBON = 1, CBF = 1, CBFDLY = 11	1.8	3.4	6.5		
t <sub>EN_CMP</sub>	Comparator enable time	CBON = 0 to CBON = 1 CBPWRMD = 00 or 01		1	2	μs	
		CBON = 0 to CBON = 1 CBPWRMD = 10			100		
t <sub>EN_REF</sub>	Resistor reference enable time	CBON = 0 to CBON = 1		0.3	1.5	μs	
V <sub>CB_REF</sub>	Reference voltage for a given tap	V <sub>IN</sub> = reference into resistor ladder (n = 0 to 31)		V <sub>IN</sub> × (n + 0.5) / 32	V <sub>IN</sub> × (n + 1) / 32	V <sub>IN</sub> × (n + 1.5) / 32	V

## 5.52 Ports PU.0 and PU.1

over recommended ranges of supply voltage and operating free-air temperature (unless otherwise noted)

PARAMETER		TEST CONDITIONS	MIN	MAX	UNIT
V <sub>OH</sub>	High-level output voltage	V <sub>USB</sub> = 3.3 V ±10%, I <sub>OH</sub> = –25 mA	2.4		V
V <sub>OL</sub>	Low-level output voltage	V <sub>USB</sub> = 3.3 V ±10%, I <sub>OL</sub> = 25 mA		0.4	V
V <sub>IH</sub>	High-level input voltage	V <sub>USB</sub> = 3.3 V ±10%	2.0		V
V <sub>IL</sub>	Low-level input voltage	V <sub>USB</sub> = 3.3 V ±10%		0.8	V

## 5.53 USB Output Ports DP and DM

over recommended ranges of supply voltage and operating free-air temperature (unless otherwise noted)

PARAMETER		TEST CONDITIONS	MIN	MAX	UNIT
V <sub>OH</sub>	D+, D- single ended	USB 2.0 load conditions	2.8	3.6	V
V <sub>OL</sub>	D+, D- single ended	USB 2.0 load conditions	0	0.3	V
Z <sub>(DRV)</sub>	D+, D- impedance	Including external series resistor of 27 Ω	28	44	Ω
t <sub>RISE</sub>	Rise time	Full speed, differential, C <sub>L</sub> = 50 pF, 10%/90%, R <sub>pu</sub> on D+	4	20	ns
t <sub>FALL</sub>	Fall time	Full speed, differential, C <sub>L</sub> = 50 pF, 10%/90%, R <sub>pu</sub> on D+	4	20	ns

## 5.54 USB Input Ports DP and DM

over recommended ranges of supply voltage and operating free-air temperature (unless otherwise noted)

PARAMETER		TEST CONDITIONS	MIN	MAX	UNIT
V <sub>(CM)</sub>	Differential input common mode range		0.8	2.5	V
Z <sub>(IN)</sub>	Input impedance		300		kΩ
V <sub>CRS</sub>	Crossover voltage		1.3	2.0	V
V <sub>IL</sub>	Static SE input logic low level			0.8	V
V <sub>IH</sub>	Static SE input logic high level		2.0		V
V <sub>DI</sub>	Differential input voltage			0.2	V

## 5.55 USB-PWR (USB Power System)

over recommended ranges of supply voltage and operating free-air temperature (unless otherwise noted)

PARAMETER		TEST CONDITIONS	MIN	TYP	MAX	UNIT
V <sub>LAUNCH</sub>	V <sub>BUS</sub> detection threshold				3.75	V
V <sub>BUS</sub>	USB bus voltage	Normal operation	3.76		5.5	V
V <sub>USB</sub>	USB LDO output voltage			3.3	±9%	V
V <sub>18</sub>	Internal USB voltage <sup>(1)</sup>			1.8		V
I <sub>USB_EXT</sub>	Maximum external current from VUSB terminal <sup>(2)</sup>	USB LDO is on			12	mA
I <sub>DET</sub>	USB LDO current overload detection <sup>(3)</sup>		60		100	mA
I <sub>SUSPEND</sub>	Operating supply current into VBUS terminal. <sup>(4)</sup>	USB LDO is on, USB PLL disabled			250	μA
C <sub>BUS</sub>	VBUS terminal recommended capacitance			4.7		μF
C <sub>USB</sub>	VUSB terminal recommended capacitance			220		nF
C <sub>18</sub>	V18 terminal recommended capacitance			220		nF
t <sub>ENABLE</sub>	Settling time V <sub>USB</sub> and V <sub>18</sub>	Within 2%, recommended capacitances			2	ms
R <sub>PUR</sub>	Pullup resistance of PUR terminal <sup>(5)</sup>		70	110	150	Ω

(1) This voltage is for internal use only. No external DC loading should be applied.

(2) This represents additional current that can be supplied to the application from the VUSB terminal beyond the needs of the USB operation.

(3) A current overload will be detected when the total current supplied from the USB LDO, including I<sub>USB\_EXT</sub>, exceeds this value.

(4) Does not include current contribution of R<sub>pu</sub> and R<sub>pd</sub> as outlined in the USB specification.

(5) This value, in series with an external resistor between PUR and D+, produces the R<sub>pu</sub> as outlined in the USB specification.

## 5.56 USB-PLL (USB Phase Locked Loop)

over recommended ranges of supply voltage and operating free-air temperature (unless otherwise noted)

PARAMETER		MIN	TYP	MAX	UNIT
$I_{PLL}$	Operating supply current			7	mA
$f_{PLL}$	PLL frequency		48		MHz
$f_{UPD}$	PLL reference frequency	1.5		3	MHz
$t_{LOCK}$	PLL lock time			2	ms
$t_{Jitter}$	PLL jitter		1000		ps

## 5.57 Flash Memory

over recommended ranges of supply voltage and operating free-air temperature (unless otherwise noted)

PARAMETER		$T_J$	MIN	TYP	MAX	UNIT
$DV_{CC(PGM/ERASE)}$	Program and erase supply voltage		1.8		3.6	V
$I_{PGM}$	Average supply current from $DV_{CC}$ during program			3	5	mA
$I_{ERASE}$	Average supply current from $DV_{CC}$ during erase			6	15	mA
$I_{MERASE}, I_{BANK}$	Average supply current from $DV_{CC}$ during mass erase or bank erase			6	15	mA
$t_{CPT}$	Cumulative program time <sup>(1)</sup>				16	ms
	Program and erase endurance		$10^4$	$10^5$		cycles
$t_{Retention}$	Data retention duration	25°C	100			years
$t_{Word}$	Word or byte program time <sup>(2)</sup>		64		85	µs
$t_{Block, 0}$	Block program time for first byte or word <sup>(2)</sup>		49		65	µs
$t_{Block, 1-(N-1)}$	Block program time for each additional byte or word, except for last byte or word <sup>(2)</sup>		37		49	µs
$t_{Block, N}$	Block program time for last byte or word <sup>(2)</sup>		55		73	µs
$t_{Seg Erase}$	Erase time for segment, mass erase, and bank erase when available <sup>(2)</sup>		23		32	ms
$f_{MCLK, MGR}$	MCLK frequency in marginal read mode (FCTL4.MGR0 = 1 or FCTL4.MGR1 = 1)		0		1	MHz

(1) The cumulative program time must not be exceeded when writing to a 128-byte flash block. This parameter applies to all programming methods: individual word write, individual byte write, and block write modes.

(2) These values are hardwired into the state machine of the flash controller.

## 5.58 JTAG and Spy-Bi-Wire Interface

over recommended ranges of supply voltage and operating free-air temperature (unless otherwise noted)

PARAMETER		TEST CONDITIONS	MIN	TYP	MAX	UNIT
$f_{SBW}$	Spy-Bi-Wire input frequency	2.2 V, 3 V	0		20	MHz
$t_{SBW, Low}$	Spy-Bi-Wire low clock pulse duration	2.2 V, 3 V	0.025		15	µs
$t_{SBW, En}$	Spy-Bi-Wire enable time (TEST high to acceptance of first clock edge) <sup>(1)</sup>	2.2 V, 3 V			1	µs
$t_{SBW, Rst}$	Spy-Bi-Wire return to normal operation time		15		100	µs
$f_{TCK}$	TCK input frequency for 4-wire JTAG <sup>(2)</sup>	2.2 V	0		5	MHz
		3 V	0		10	
$R_{internal}$	Internal pulldown resistance on TEST	2.2 V, 3 V	45	60	80	kΩ

(1) Tools that access the Spy-Bi-Wire interface must wait for the  $t_{SBW, En}$  time after pulling the TEST/SBWTCK pin high before applying the first SBWTCK clock edge.

(2)  $f_{TCK}$  may be restricted to meet the timing requirements of the module selected.

## 6 Detailed Description

### 6.1 CPU ([Link to User's Guide](#))

The MSP430 CPU has a 16-bit RISC architecture that is highly transparent to the application. All operations, other than program-flow instructions, are performed as register operations in conjunction with seven addressing modes for source operand and four addressing modes for destination operand.

The CPU is integrated with 16 registers that provide reduced instruction execution time. The register-to-register operation execution time is one cycle of the CPU clock. Four of the registers, R0 to R3, are dedicated as program counter, stack pointer, status register, and constant generator, respectively. The remaining registers are general-purpose registers (see [Figure 6-1](#)).

Peripherals are connected to the CPU using data, address, and control buses. The peripherals can be managed with all instructions.

Program Counter	PC/R0
Stack Pointer	SP/R1
Status Register	SR/CG1/R2
Constant Generator	CG2/R3
General-Purpose Register	R4
General-Purpose Register	R5
General-Purpose Register	R6
General-Purpose Register	R7
General-Purpose Register	R8
General-Purpose Register	R9
General-Purpose Register	R10
General-Purpose Register	R11
General-Purpose Register	R12
General-Purpose Register	R13
General-Purpose Register	R14
General-Purpose Register	R15

**Figure 6-1. Integrated CPU Registers**

## 6.2 Instruction Set

The instruction set consists of the original 51 instructions with three formats and seven address modes and additional instructions for the expanded address range. Each instruction can operate on word and byte data. [Table 6-1](#) lists examples of the three types of instruction formats. [Table 6-2](#) lists the address modes.

**Table 6-1. Instruction Word Formats**

INSTRUCTION WORD FORMAT	EXAMPLE	OPERATION
Dual operands, source-destination	ADD R4,R5	R4 + R5 → R5
Single operands, destination only	CALL R8	PC → (TOS), R8 → PC
Relative jump, unconditional or conditional	JNE	Jump-on-equal bit = 0

**Table 6-2. Address Mode Descriptions**

ADDRESS MODE	S <sup>(1)</sup>	D <sup>(1)</sup>	SYNTAX	EXAMPLE	OPERATION
Register	+	+	MOV Rs,Rd	MOV R10,R11	R10 → R11
Indexed	+	+	MOV X(Rn),Y(Rm)	MOV 2(R5),6(R6)	M(2+R5) → M(6+R6)
Symbolic (PC relative)	+	+	MOV EDE,TONI		M(EDE) → M(TONI)
Absolute	+	+	MOV &MEM, &TCDAT		M(MEM) → M(TCDAT)
Indirect	+		MOV @Rn,Y(Rm)	MOV @R10,Tab(R6)	M(R10) → M(Tab+R6)
Indirect auto-increment	+		MOV @Rn+,Rm	MOV @R10+,R11	M(R10) → R11 R10 + 2 → R10
Immediate	+		MOV #X,TONI	MOV #45,TONI	#45 → M(TONI)

(1) S = source, D = destination

## 6.3 Operating Modes

The MCUs have one active mode and seven software-selectable low-power modes of operation. An interrupt event can wake up the device from any of the low-power modes, service the request, and restore back to the low-power mode on return from the interrupt program.

Software can configure the following operating modes:

- Active mode (AM)
  - All clocks are active
- Low-power mode 0 (LPM0)
  - CPU is disabled
  - ACLK and SMCLK remain active, MCLK is disabled
  - FLL loop control remains active
- Low-power mode 1 (LPM1)
  - CPU is disabled
  - FLL loop control is disabled
  - ACLK and SMCLK remain active, MCLK is disabled
- Low-power mode 2 (LPM2)
  - CPU is disabled
  - MCLK, FLL loop control, and DCOCLK are disabled
  - DC generator of the DCO remains enabled
  - ACLK remains active
- Low-power mode 3 (LPM3)
  - CPU is disabled
  - MCLK, FLL loop control, and DCOCLK are disabled
  - DC generator of the DCO is disabled
  - ACLK remains active
- Low-power mode 4 (LPM4)
  - CPU is disabled
  - ACLK is disabled
  - MCLK, FLL loop control, and DCOCLK are disabled
  - DC generator of the DCO is disabled
  - Crystal oscillator is stopped
  - Complete data retention
- Low-power mode 3.5 (LPM3.5)
  - Internal regulator disabled
  - No data retention
  - RTC enabled and clocked by low-frequency oscillator
  - Wake-up input from  $\overline{\text{RST}}/\text{NMI}$ , RTC\_B, P1, P2, P3, and P4
- Low-power mode 4.5 (LPM4.5)
  - Internal regulator disabled
  - No data retention
  - Wake-up input from  $\overline{\text{RST}}/\text{NMI}$ , P1, P2, P3, and P4

## 6.4 Interrupt Vector Addresses

The interrupt vectors and the power-up start address are in the address range 0FFFFh to 0FF80h (see Table 6-3). The vector contains the 16-bit address of the appropriate interrupt-handler instruction sequence.

**Table 6-3. Interrupt Sources, Flags, and Vectors**

INTERRUPT SOURCE	INTERRUPT FLAG	SYSTEM INTERRUPT	WORD ADDRESS	PRIORITY
<b>System Reset</b> Power up, External Reset Watchdog time-out, key violation Flash memory key violation	WDTIFG, KEYV (SYSRSTIV) <sup>(1) (2)</sup>	Reset	0FFFEh	63, highest
<b>System NMI</b> PMM Vacant memory access JTAG mailbox	SVMLIFG, SVMHIFG, DLYLIFG, DLYHIFG, SVMLVLRIFG, SVMHVLRFIFG, VMAIFG, JMBINIFG, JMBOUTIFG (SYSSNIV) <sup>(1)</sup>	(Non)maskable	0FFFCh	62
<b>User NMI</b> NMI Oscillator fault Flash memory access violation	NMIIFG, OFIFG, ACCVIFG, BUSIFG (SYSUNIV) <sup>(1) (2)</sup>	(Non)maskable	0FFFAh	61
Comp_B	Comparator B interrupt flags (CBIV) <sup>(1) (3)</sup>	Maskable	0FFF8h	60
Timer TB0	TB0CCR0 CCIFG0 <sup>(3)</sup>	Maskable	0FFF6h	59
Timer TB0	TB0CCR1 CCIFG1 to TB0CCR6 CCIFG6, TB0IFG (TB0IV) <sup>(1) (3)</sup>	Maskable	0FFF4h	58
Watchdog interval timer mode	WDTIFG	Maskable	0FFF2h	57
USCI_A0 receive or transmit	UCA0RXIFG, UCA0TXIFG (UCA0IV) <sup>(1) (3)</sup>	Maskable	0FFF0h	56
USCI_B0 receive or transmit	UCB0RXIFG, UCB0TXIFG (UCB0IV) <sup>(1) (3)</sup>	Maskable	0FFEEh	55
ADC12_A	ADC12IFG0 to ADC12IFG15 (ADC12IV) <sup>(1) (3)</sup>	Maskable	0FFECCh	54
Timer TA0	TA0CCR0 CCIFG0 <sup>(3)</sup>	Maskable	0FFEAh	53
Timer TA0	TA0CCR1 CCIFG1 to TA0CCR4 CCIFG4, TA0IFG (TA0IV) <sup>(1) (3)</sup>	Maskable	0FFE8h	52
USB_UBM <sup>(4)</sup>	USB interrupts (USBIV) <sup>(1) (3)</sup>	Maskable	0FFE6h	51
LDO-PWR <sup>(5)</sup>	LDOOFFIFG, LDOONIFG, LDOOVLIFG			
DMA	DMA0IFG, DMA1IFG, DMA2IFG, DMA3IFG, DMA4IFG, DMA5IFG (DMAIV) <sup>(1) (3)</sup>	Maskable	0FFE4h	50
Timer TA1	TA1CCR0 CCIFG0 <sup>(3)</sup>	Maskable	0FFE2h	49
Timer TA1	TA1CCR1 CCIFG1 to TA1CCR2 CCIFG2, TA1IFG (TA1IV) <sup>(1) (3)</sup>	Maskable	0FFE0h	48
I/O Port P1	P1IFG.0 to P1IFG.7 (P1IV) <sup>(1)(3)</sup>	Maskable	0FFDEh	47
USCI_A1 receive or transmit	UCA1RXIFG, UCA1TXIFG (UCA1IV) <sup>(1) (3)</sup>	Maskable	0FFDCh	46
USCI_B1 receive or transmit	UCB1RXIFG, UCB1TXIFG (UCB1IV) <sup>(1) (3)</sup>	Maskable	0FFDAh	45
I/O port P2	P2IFG.0 to P2IFG.7 (P2IV) <sup>(1) (3)</sup>	Maskable	0FFD8h	44
LCD_B <sup>(6)</sup>	LCD_B Interrupt Flags (LCDBIV) <sup>(1)</sup>	Maskable	0FFD6h	43
RTC_B	RTCRDYIFG, RTCTEVIFG, RTCAIFG, RT0PSIFG, RT1PSIFG, RTCOFIFG (RTCIV) <sup>(1) (3)</sup>	Maskable	0FFD4h	42
DAC12_A	DAC12_0IFG, DAC12_1IFG <sup>(1) (3)</sup>	Maskable	0FFD2h	41
Timer TA2	TA2CCR0 CCIFG0 <sup>(3)</sup>	Maskable	0FFD0h	40
Timer TA2	TA2CCR1 CCIFG1 to TA2CCR2 CCIFG2, TA2IFG (TA2IV) <sup>(1) (3)</sup>	Maskable	0FFCEh	39

(1) Multiple source flags

(2) A reset is generated if the CPU tries to fetch instructions from within peripheral space or vacant memory space.

(Non)maskable: the individual interrupt enable bit can disable an interrupt event, but the general interrupt enable bit cannot disable it.

(3) Interrupt flags are in the module.

(4) Only on devices with peripheral module USB (MSP430F665x and MSP430F565x)

(5) Only on devices with peripheral module LDO-PWR (MSP430F535x and MSP430F645x)

(6) Only on devices with peripheral module LCD\_B (MSP430F665x and MSP430F645x), otherwise reserved (MSP430F535x and MSP430F565x)

**Table 6-3. Interrupt Sources, Flags, and Vectors (continued)**

INTERRUPT SOURCE	INTERRUPT FLAG	SYSTEM INTERRUPT	WORD ADDRESS	PRIORITY
I/O port P3	P3IFG.0 to P3IFG.7 (P3IV) <sup>(1) (3)</sup>	Maskable	0FFCCh	38
I/O Port P4	P4IFG.0 to P4IFG.7 (P4IV) <sup>(1) (3)</sup>	Maskable	0FFCAh	37
USCI_A2 receive or transmit	UCA2RXIFG, UCA2TXIFG (UCA2IV) <sup>(1) (3)</sup>		0FFC8h	36
USCI_B2 receive or transmit	UCB2RXIFG, UCB2TXIFG (UCB2IV) <sup>(1) (3)</sup>		0FFC6h	35
Reserved	Reserved <sup>(7)</sup>		0FFC4h	34
			⋮	⋮
			0FF80h	0, lowest

(7) Reserved interrupt vectors at addresses are not used in this device and can be used for regular program code if necessary. To maintain compatibility with other devices, TI recommends reserving these locations.

## 6.5 Memory Organization

Table 6-4 summarizes the memory map of all device variants.

**Table 6-4. Memory Organization<sup>(1)</sup>**

		MSP430F6458 MSP430F5358	MSP430F6459 MSP430F5359	MSP430F6658 MSP430F5658	MSP430F6659 MSP430F5659
Memory (flash)	Total Size	384KB	512KB	384KB	512KB
Main: interrupt vector		00FFFFh to 00FF80h	00FFFFh to 00FF80h	00FFFFh to 00FF80h	00FFFFh to 00FF80h
Main: code memory	Bank 3	N/A	128KB 087FFFh to 068000h	N/A	128KB 087FFFh to 068000h
	Bank 2	128KB 067FFFh to 048000h	128KB 067FFFh-48000h	128KB 067FFFh to 048000h	128KB 067FFFh-48000h
	Bank 1	128KB 047FFFh to 028000h	128KB 047FFFh to 028000h	128KB 047FFFh to 028000h	128KB 047FFFh to 028000h
	Bank 0	128KB 027FFFh to 008000h	128KB 027FFFh to 008000h	128KB 027FFFh to 008000h	128KB 027FFFh to 008000h
MID support software (ROM)	Total Size	1KB 006FFFh to 006C00h	1KB 006FFFh to 006C00h	1KB 006FFFh to 006C00h	1KB 006FFFh to 006C00h
RAM	Sector 3	16KB 0FBFFFh to 0F8000h	16KB 0FBFFFh to 0F8000h	16KB 0FBFFFh to 0F8000h	16KB 0FBFFFh to 0F8000h
	Sector 2	N/A	16KB 0F7FFFh to 0F4000h	N/A	16KB 0F7FFFh to 0F4000h
	Sector 1	N/A	16KB 0F3FFFh to 0F0000h	N/A	16KB 0F3FFFh to 0F0000h
	Sector 0	16KB 0063FFh to 002400h (mirrored at address range 0FFFFFh to 0FC000h)	16KB 0063FFh to 002400h (mirrored at address range 0FFFFFh to 0FC000h)	16KB 0063FFh to 002400h (mirrored at address range 0FFFFFh to 0FC000h)	16KB 0063FFh to 002400h (mirrored at address range 0FFFFFh to 0FC000h)
RAM <sup>(2)</sup>	Sector 7	2KB 0023FFh to 001C00h	2KB 0023FFh to 001C00h	N/A	N/A
USB RAM <sup>(3)</sup>	Sector 7	N/A	N/A	2KB 0023FFh to 001C00h	2KB 0023FFh to 001C00h
Information memory (flash)	Info A	128 B 0019FFh to 001980h	128 B 0019FFh to 001980h	128 B 0019FFh to 001980h	128 B 0019FFh to 001980h
	Info B	128 B 00197Fh to 001900h	128 B 00197Fh to 001900h	128 B 00197Fh to 001900h	128 B 00197Fh to 001900h
	Info C	128 B 0018FFh to 001880h	128 B 0018FFh to 001880h	128 B 0018FFh to 001880h	128 B 0018FFh to 001880h
	Info D	128 B 00187Fh to 001800h	128 B 00187Fh to 001800h	128 B 00187Fh to 001800h	128 B 00187Fh to 001800h
Bootloader (BSL) memory (flash)	BSL 3	512 B 0017FFh to 001600h	512 B 0017FFh to 001600h	512 B 0017FFh to 001600h	512 B 0017FFh to 001600h
	BSL 2	512 B 0015FFh to 001400h	512 B 0015FFh to 001400h	512 B 0015FFh to 001400h	512 B 0015FFh to 001400h
	BSL 1	512 B 0013FFh to 001200h	512 B 0013FFh to 001200h	512 B 0013FFh to 001200h	512 B 0013FFh to 001200h
	BSL 0	512 B 0011FFh to 001000h	512 B 0011FFh to 001000h	512 B 0011FFh to 001000h	512 B 0011FFh to 001000h
Peripherals	Size	4KB 000FFFh to 000000h	4KB 000FFFh to 000000h	4KB 000FFFh to 000000h	4KB 000FFFh to 000000h

(1) N/A = Not available

(2) Only available on F6459, F6458, F5359, F5358 devices.

(3) Only available on F6659, F6658, F5659, F5658 devices. USB RAM can be used as general-purpose RAM when not used for USB operation.

## 6.6 Bootloader (BSL)

The BSL enables users to program the flash memory or RAM using various serial interfaces. Access to the device memory by the BSL is protected by an user-defined password. For complete description of the features of the BSL and its implementation, see the [MSP430 Flash Device Bootloader \(BSL\) User's Guide](#).

### 6.6.1 USB BSL

The devices MSP430F565x and MSP430F665x come preprogrammed with the USB BSL. Use of the USB BSL requires external access to six pins (see [Table 6-5](#)). In addition to these pins, the application must support external components necessary for normal USB operation; for example, the proper crystal on XT2IN and XT2OUT or proper decoupling.

**Table 6-5. USB BSL Pin Requirements and Functions**

DEVICE SIGNAL	BSL FUNCTION
$\overline{\text{RST}}/\text{NMI}/\text{SBWTDIO}$	Entry sequence signal
PU.0/DP	USB data terminal DP
PU.1/DM	USB data terminal DM
PUR	USB pullup resistor terminal
VBUS	USB bus power supply
VSSU	USB ground supply

#### NOTE

The default USB BSL evaluates the logic level of the PUR pin after a BOR reset. If it is pulled high externally, then the BSL is invoked. Therefore, unless the application is invoking the BSL, it is important to keep PUR pulled low after a BOR reset, even if BSL or USB is never used. TI recommends applying a 1-M $\Omega$  resistor to ground.

### 6.6.2 UART BSL

All devices without a USB module (MSP430F535x and MSP430F645x) come preprogrammed with the UART BSL. A UART BSL is also available for devices with USB module that can be programmed by the user into the BSL memory by replacing the preprogrammed, factory supplied, USB BSL. Use of the UART BSL requires external access to six pins (see [Table 6-6](#)).

**Table 6-6. UART BSL Pin Requirements and Functions**

DEVICE SIGNAL	BSL FUNCTION
$\overline{\text{RST}}/\text{NMI}/\text{SBWTDIO}$	Entry sequence signal
TEST/SBWTK	Entry sequence signal
P1.1	Data transmit
P1.2	Data receive
VCC	Power supply
VSS	Ground supply

## 6.7 JTAG Operation

### 6.7.1 JTAG Standard Interface

The MSP430 family supports the standard JTAG interface which requires four signals for sending and receiving data. The JTAG signals are shared with general-purpose I/O. The TEST/SBWTCK pin is used to enable the JTAG signals. In addition to these signals, the  $\overline{\text{RST}}/\text{NMI}/\text{SBWTDIO}$  is required to interface with MSP430 development tools and device programmers. [Table 6-7](#) lists the JTAG pin requirements. For further details on interfacing to development tools and device programmers, see the [MSP430 Hardware Tools User's Guide](#). For a complete description of the features of the BSL and its implementation, see [MSP430 Programming With the JTAG Interface](#).

**Table 6-7. JTAG Pin Requirements and Functions**

DEVICE SIGNAL	DIRECTION	FUNCTION
PJ.3/TCK	IN	JTAG clock input
PJ.2/TMS	IN	JTAG state control
PJ.1/TDI/TCLK	IN	JTAG data input, TCLK input
PJ.0/TDO	OUT	JTAG data output
TEST/SBWTCK	IN	Enable JTAG pins
$\overline{\text{RST}}/\text{NMI}/\text{SBWTDIO}$	IN	External reset
VCC		Power supply
VSS		Ground supply

### 6.7.2 Spy-Bi-Wire Interface

In addition to the standard JTAG interface, the MSP430 family supports the two wire Spy-Bi-Wire interface. Spy-Bi-Wire can be used to interface with MSP430 development tools and device programmers. [Table 6-8](#) lists the Spy-Bi-Wire interface pin requirements. For further details on interfacing to development tools and device programmers, see the [MSP430 Hardware Tools User's Guide](#). For a complete description of the features of the JTAG interface and its implementation, see [MSP430 Programming With the JTAG Interface](#).

**Table 6-8. Spy-Bi-Wire Pin Requirements and Functions**

DEVICE SIGNAL	DIRECTION	FUNCTION
TEST/SBWTCK	IN	Spy-Bi-Wire clock input
$\overline{\text{RST}}/\text{NMI}/\text{SBWTDIO}$	IN, OUT	Spy-Bi-Wire data input and output
VCC		Power supply
VSS		Ground supply

## 6.8 Flash Memory ([Link to User's Guide](#))

The flash memory can be programmed through the JTAG port, Spy-Bi-Wire (SBW), the BSL, or in-system by the CPU. The CPU can perform single-byte, single-word, and long-word writes to the flash memory. Features of the flash memory include:

- Flash memory has n segments of main memory and four segments of information memory (A to D) of 128 bytes each. Each segment in main memory is 512 bytes in size.
- Segments 0 to n may be erased in one step, or each segment may be individually erased.
- Segments A to D can be erased individually, or as a group with segments 0 to n. Segments A to D are also called *information memory*.
- Segment A can be locked separately.

## 6.9 Memory Integrity Detection (MID) ([Link to User's Guide](#))

The MID is an add-on to the flash memory controller. MID provides additional functionality over the regular flash operation methods. The main purpose of the MID function is to gain higher reliability of flash content and overall system integrity in harsh environments and in application areas that require such features. The on-chip MID ROM contains the factory-programmed MID support software. This software package provides several software functions that allow an application to use all of the features of the MID.

The MID functionality can be enabled for different flash memory ranges. These memory ranges are selectable by the cw0 parameter of the MID function MidEnable() (see [Table 6-9](#)).

**Table 6-9. Address Range Coverage of cw0 Parameter of MidEnable() Function**

BITS OF cw0 PARAMETER	MSP430F6659 MSP430F6459 MSP430F5659 MSP430F5359	MSP430F6658 MSP430F6458 MSP430F5658 MSP430F5358
cw0.15	087FFFh to 080000h	N/A
cw0.14	07FFFFh to 078000h	N/A
cw0.13	077FFFh to 070000h	N/A
cw0.12	06FFFFh to 068000h	N/A
cw0.11	067FFFh to 060000h	067FFFh to 060000h
cw0.10	05FFFFh to 058000h	05FFFFh to 058000h
cw0.9	057FFFh to 050000h	057FFFh to 050000h
cw0.8	04FFFFh to 048000h	04FFFFh to 048000h
cw0.7	047FFFh to 040000h	047FFFh to 040000h
cw0.6	03FFFFh to 038000h	03FFFFh to 038000h
cw0.5	037FFFh to 030000h	037FFFh to 030000h
cw0.4	02FFFFh to 028000h	02FFFFh to 028000h
cw0.3	027FFFh to 020000h	027FFFh to 020000h
cw0.2	01FFFFh to 018000h	01FFFFh to 018000h
cw0.1	017FFFh to 010000h	017FFFh to 010000h
cw0.0	00FFFFh to 008000h	00FFFFh to 008000h

## 6.10 RAM ([Link to User's Guide](#))

The RAM is made up of n sectors. Each sector can be completely powered down to save leakage; however, all data are lost. Features of the RAM include:

- RAM has n sectors. The size of a sector can be found in [Section 6.5](#).
- Each sector 0 to n can be complete disabled; however, data retention is lost.
- Each sector 0 to n automatically enters low-power retention mode when possible.
- For devices that contain USB memory, the USB memory can be used as normal RAM if USB is not required.

## 6.11 Backup RAM ([Link to User's Guide](#))

The backup RAM provides a limited number of bytes of RAM that are retained during LPMx.5 and during operation from a backup supply if the battery backup system module is implemented.

There are 8 bytes of backup RAM available. It can be word-wise accessed by the control registers BAKMEM0, BAKMEM1, BAKMEM2, and BAKMEM3.

## 6.12 Peripherals

Peripherals are connected to the CPU through data, address, and control buses. Peripherals can be managed using all instructions. For complete module descriptions, see the [MSP430F5xx and MSP430F6xx Family User's Guide](#).

### 6.12.1 Digital I/O ([Link to User's Guide](#))

Nine 8-bit I/O ports are implemented: P1 through P9 are complete, and port PJ contains four individual I/O ports.

- All individual I/O bits are independently programmable.
- Any combination of input, output, and interrupt conditions is possible.
- Programmable pullup or pulldown on all ports.
- Programmable drive strength on all ports.
- Edge-selectable interrupt input capability for all the eight bits of ports P1, P2, P3, and P4.
- Read and write access to port-control registers is supported by all instructions.
- Ports can be accessed byte-wise (P1 through P9) or word-wise in pairs (PA through PD).

### 6.12.2 Port Mapping Controller ([Link to User's Guide](#))

The port mapping controller allows the flexible and reconfigurable mapping of digital functions to port P2. [Table 6-10](#) lists the available mappings, and [Table 6-11](#) lists the default settings.

**Table 6-10. Port Mapping Mnemonics and Functions**

VALUE	PxMAPy MNEMONIC	INPUT PIN FUNCTION	OUTPUT PIN FUNCTION
0	PM_NONE	None	DVSS
1	PM_CBOUT	–	Comparator_B output
	PM_TB0CLK	Timer TB0 clock input	–
2	PM_ADC12CLK	–	ADC12CLK
	PM_DMAE0	DMAE0 Input	–
3	PM_SVMOUT	–	SVM output
	PM_TB0OUTH	Timer TB0 high impedance input TB0OUTH	–
4	PM_TB0CCR0B	Timer TB0 CCR0 capture input CCI0B	Timer TB0: TB0.0 compare output Out0
5	PM_TB0CCR1B	Timer TB0 CCR1 capture input CCI1B	Timer TB0: TB0.1 compare output Out1
6	PM_TB0CCR2B	Timer TB0 CCR2 capture input CCI2B	Timer TB0: TB0.2 compare output Out2
7	PM_TB0CCR3B	Timer TB0 CCR3 capture input CCI3B	Timer TB0: TB0.3 compare output Out3
8	PM_TB0CCR4B	Timer TB0 CCR4 capture input CCI4B	Timer TB0: TB0.4 compare output Out4
9	PM_TB0CCR5B	Timer TB0 CCR5 capture input CCI5B	Timer TB0: TB0.5 compare output Out5
10	PM_TB0CCR6B	Timer TB0 CCR6 capture input CCI6B	Timer TB0: TB0.6 compare output Out6
11	PM_UCA0RXD	USCI_A0 UART RXD (Direction controlled by USCI – input)	
	PM_UCA0SOMI	USCI_A0 SPI slave out master in (direction controlled by USCI)	
12	PM_UCA0TXD	USCI_A0 UART TXD (Direction controlled by USCI – output)	
	PM_UCA0SIMO	USCI_A0 SPI slave in master out (direction controlled by USCI)	
13	PM_UCA0CLK	USCI_A0 clock input/output (direction controlled by USCI)	
	PM_UCB0STE	USCI_B0 SPI slave transmit enable (direction controlled by USCI – input)	
14	PM_UCB0SOMI	USCI_B0 SPI slave out master in (direction controlled by USCI)	
	PM_UCB0SCL	USCI_B0 I2C clock (open drain and direction controlled by USCI)	
15	PM_UCB0SIMO	USCI_B0 SPI slave in master out (direction controlled by USCI)	
	PM_UCB0SDA	USCI_B0 I2C data (open drain and direction controlled by USCI)	
16	PM_UCB0CLK	USCI_B0 clock input/output (direction controlled by USCI)	
	PM_UCA0STE	USCI_A0 SPI slave transmit enable (direction controlled by USCI – input)	

**Table 6-10. Port Mapping Mnemonics and Functions (continued)**

VALUE	PxMAPy MNEMONIC	INPUT PIN FUNCTION	OUTPUT PIN FUNCTION
17	PM_MCLK	–	MCLK
18	Reserved	Reserved for test purposes. Do not use this setting.	
19	Reserved	Reserved for test purposes. Do not use this setting.	
20-30	Reserved	None	DVSS
31 (0FFh) <sup>(1)</sup>	PM_ANALOG	Disables the output driver and the input Schmitt-trigger to prevent parasitic cross currents when applying analog signals.	

(1) The value of the PM\_ANALOG mnemonic is set to 0FFh. The port mapping registers are only 5 bits wide, and the upper bits are ignored, which results in a read value of 31.

**Table 6-11. Default Mapping**

PIN	PxMAPy MNEMONIC	INPUT PIN FUNCTION	OUTPUT PIN FUNCTION
P2.0/P2MAP0	PM_UCB0STE, PM_UCA0CLK	USCI_B0 SPI slave transmit enable (direction controlled by USCI – input), USCI_A0 clock input/output (direction controlled by USCI)	
P2.1/P2MAP1	PM_UCB0SIMO, PM_UCB0SDA	USCI_B0 SPI slave in master out (direction controlled by USCI), USCI_B0 I2C data (open drain and direction controlled by USCI)	
P2.2/P2MAP2	PM_UCB0SOMI, PM_UCB0SCL	USCI_B0 SPI slave out master in (direction controlled by USCI), USCI_B0 I2C clock (open drain and direction controlled by USCI)	
P2.3/P2MAP3	PM_UCB0CLK, PM_UCA0STE	USCI_B0 clock input/output (direction controlled by USCI), USCI_A0 SPI slave transmit enable (direction controlled by USCI – input)	
P2.4/P2MAP4	PM_UCA0TXD, PM_UCA0SIMO	USCI_A0 UART TXD (direction controlled by USCI – output), USCI_A0 SPI slave in master out (direction controlled by USCI)	
P2.5/P2MAP5	PM_UCA0RXD, PM_UCA0SOMI	USCI_A0 UART RXD (direction controlled by USCI – input), USCI_A0 SPI slave out master in (direction controlled by USCI)	
P2.6/P2MAP6/ R03	PM_NONE	–	DVSS
P2.7/P2MAP7/LCDREF/R13	PM_NONE	–	DVSS

### 6.12.3 Oscillator and System Clock ([Link to User's Guide](#))

The clock system is supported by the Unified Clock System (UCS) module that includes support for a 32-kHz watch crystal oscillator (in XT1 LF mode; XT1 HF mode is not supported), an internal very-low-power low-frequency oscillator (VLO), an internal trimmed low-frequency oscillator (REFO), an integrated internal digitally controlled oscillator (DCO), and a high-frequency crystal oscillator (XT2). The UCS module is designed to meet the requirements of both low system cost and low power consumption. The UCS module features digital frequency locked loop (FLL) hardware that, in conjunction with a digital modulator, stabilizes the DCO frequency to a programmable multiple of the watch crystal frequency. The internal DCO provides a fast turnon clock source and stabilizes in 3  $\mu$ s (typical). The UCS module provides the following clock signals:

- Auxiliary clock (ACLK), sourced from a 32-kHz watch crystal (XT1), a high-frequency crystal (XT2), the internal low-frequency oscillator (VLO), the trimmed low-frequency oscillator (REFO), or the internal digitally-controlled oscillator DCO.
- Main clock (MCLK), the system clock used by the CPU. MCLK can be sourced by same sources available to ACLK.
- Sub-Main clock (SMCLK), the subsystem clock used by the peripheral modules. SMCLK can be sourced by same sources available to ACLK.
- ACLK/n, the buffered output of ACLK, ACLK/2, ACLK/4, ACLK/8, ACLK/16, ACLK/32.

#### 6.12.4 Power-Management Module (PMM) ([Link to User's Guide](#))

The PMM includes an integrated voltage regulator that supplies the core voltage to the device and contains programmable output levels to provide for power optimization. The PMM also includes supply voltage supervisor (SVS) and supply voltage monitoring (SVM) circuitry, as well as brownout protection. The brownout circuit is implemented to provide the proper internal reset signal to the device during power-on and power-off. The SVS and SVM circuitry detects if the supply voltage drops below a user-selectable level and supports both supply voltage supervision (the device is automatically reset) and supply voltage monitoring (the device is not automatically reset). SVS and SVM circuitry is available on the primary supply and core supply.

#### 6.12.5 Hardware Multiplier (MPY) ([Link to User's Guide](#))

The multiplication operation is supported by a dedicated peripheral module. The module performs operations with 32-, 24-, 16-, and 8-bit operands. The module supports signed and unsigned multiplication as well as signed and unsigned multiply-and-accumulate operations.

#### 6.12.6 Real-Time Clock (RTC\_B) ([Link to User's Guide](#))

The RTC\_B module can be configured for real-time clock (RTC) or calendar mode providing seconds, minutes, hours, day of week, day of month, month, and year. Calendar mode integrates an internal calendar which compensates for months with less than 31 days and includes leap year correction. The RTC\_B also supports flexible alarm functions and offset-calibration hardware. The implementation on this device supports operation in LPM3.5 mode and operation from a backup supply.

*Using the MSP430 RTC\_B Module With Battery Backup Supply* describes how to use the RTC\_B with battery backup supply functionality to retain the time and keep the RTC counting through loss of main power supply, as well as how to handle correct reinitialization when the main power supply is restored.

#### 6.12.7 Watchdog Timer (WDT\_A) ([Link to User's Guide](#))

The primary function of the WDT\_A module is to perform a controlled system restart after a software problem occurs. If the selected time interval expires, a system reset is generated. If the watchdog function is not needed in an application, the module can be configured as an interval timer and can generate interrupts at selected time intervals.

#### 6.12.8 System Module (SYS) ([Link to User's Guide](#))

The SYS module handles many of the system functions within the device. These include power-on reset and power-up clear handling, NMI source selection and management, reset interrupt vector generators, bootloader entry mechanisms, and configuration management (device descriptors). SYS also includes a data exchange mechanism using JTAG called a JTAG mailbox that can be used in the application. [Table 6-12](#) lists the SYS module interrupt vector registers.

**Table 6-12. System Module Interrupt Vector Registers**

INTERRUPT VECTOR REGISTER	INTERRUPT EVENT	WORD ADDRESS	OFFSET	PRIORITY	
SYSRSTIV, System Reset	No interrupt pending	019Eh	00h	Highest	
	Brownout (BOR)		02h		
	RST/NMI (BOR)		04h		
	PMMSWBOR (BOR)		06h		
	LPM3.5 or LPM4.5 wakeup (BOR)		08h		
	Security violation (BOR)		0Ah		
	SVSL (POR)		0Ch		
	SVSH (POR)		0Eh		
	SVML_OVP (POR)		10h		
	SVMH_OVP (POR)		12h		
	PMMSWPOR (POR)		14h		
	WDT time-out (PUC)		16h		
	WDT key violation (PUC)		18h		
	KEYV flash key violation (PUC)		1Ah		
	Reserved		1Ch		
	Peripheral area fetch (PUC)		1Eh		
	PMM key violation (PUC)		20h		
Reserved	22h to 3Eh	Lowest			
SYSSNIV, System NMI	No interrupt pending	019Ch	00h	Highest	
	SVMLIFG		02h		
	SVMHIFG		04h		
	DLYLIFG		06h		
	DLYHIFG		08h		
	VMAIFG		0Ah		
	JMBINIFG		0Ch		
	JMBOUTIFG		0Eh		
	SVMLVLRIFG		10h		
	SVMHVLRIFG		12h		
	Reserved		14h to 1Eh		Lowest
	SYSUNIV, User NMI		No interrupt pending		019Ah
NMIIFG		02h			
OFIFG		04h			
ACCVIFG		06h			
BUSIFG		08h			
Reserved		0Ah to 1Eh	Lowest		
SYSBERRIV, Bus Error		No interrupt pending	0198h	00h	
	USB wait state time-out	02h			
	Reserved	04h			
	MID error	06h			
	Reserved	08h to 1Eh		Lowest	

### 6.12.9 DMA Controller [\(Link to User's Guide\)](#)

The DMA controller allows movement of data from one memory address to another without CPU intervention. For example, the DMA controller can be used to move data from the ADC12\_A conversion memory to RAM. Using the DMA controller can increase the throughput of peripheral modules. The DMA controller reduces system power consumption by allowing the CPU to remain in sleep mode, without having to awaken to move data to or from a peripheral.

The USB timestamp generator also uses the channel 0, 1, and 2 DMA trigger assignments described in [Table 6-13](#). The USB timestamp generator is available only on devices with the USB module (MSP430F565x and MSP430F665x).

**Table 6-13. DMA Trigger Assignments<sup>(1)</sup>**

TRIGGER	CHANNEL					
	0	1	2	3	4	5
0	DMAREQ					
1	TA0CCR0 CCIFG					
2	TA0CCR2 CCIFG					
3	TA1CCR0 CCIFG					
4	TA1CCR2 CCIFG					
5	TA2CCR0 CCIFG					
6	TA2CCR2 CCIFG					
7	TBCCR0 CCIFG					
8	TBCCR2 CCIFG					
9	Reserved					
10	Reserved					
11	Reserved					
12	UCA2RXIFG					
13	UCA2TXIFG					
14	UCB2RXIFG					
15	UCB2TXIFG					
16	UCA0RXIFG					
17	UCA0TXIFG					
18	UCB0RXIFG					
19	UCB0TXIFG					
20	UCA1RXIFG					
21	UCA1TXIFG					
22	UCB1RXIFG					
23	UCB1TXIFG					
24	ADC12IFGx					
25	DAC12_0IFG					
26	DAC12_1IFG					
27	USB FNRXD <sup>(2)</sup>					
28	USB ready <sup>(2)</sup>					
29	MPY ready					
30	DMA5IFG	DMA0IFG	DMA1IFG	DMA2IFG	DMA3IFG	DMA4IFG
31	DMAE0					

- (1) Reserved DMA triggers may be used by other devices in the family. Reserved DMA triggers do not cause any DMA trigger event when selected.
- (2) Only on devices with peripheral module USB (MSP430F565x and MSP430F665x), otherwise reserved (MSP430F535x and MSP430F645x).

### 6.12.10 Universal Serial Communication Interface (USCI) (Links to User's Guide: [UART Mode](#), [SPI Mode](#), [I<sup>2</sup>C Mode](#))

The USCI modules are used for serial data communication. The USCI module supports synchronous communication protocols such as SPI (3- or 4-pin) and I<sup>2</sup>C, and asynchronous communication protocols such as UART, enhanced UART with automatic baudrate detection, and IrDA. Each USCI module contains two portions, A and B.

The USCI\_An module provides support for SPI (3- or 4-pin), UART, enhanced UART, or IrDA.

The USCI\_Bn module provides support for SPI (3- or 4-pin) or I<sup>2</sup>C.

The MSP430F665x, MSP430F645x, MSP430F565x, MSP430F535x MCUs include three complete USCI modules (n = 0 to 2).

### 6.12.11 Timer TA0 (Link to User's Guide)

Timer TA0 is a 16-bit timer/counter (Timer\_A type) with five capture/compare registers. TA0 supports multiple capture/compares, PWM outputs, and interval timing (see [Table 6-14](#)). TA0 also has extensive interrupt capabilities. Interrupts may be generated from the counter on overflow conditions and from each of the capture/compare registers.

**Table 6-14. Timer TA0 Signal Connections**

INPUT PIN NUMBER		DEVICE INPUT SIGNAL	MODULE INPUT SIGNAL	MODULE BLOCK	MODULE OUTPUT SIGNAL	DEVICE OUTPUT SIGNAL	OUTPUT PIN NUMBER	
PZ	ZQW						PZ	ZQW
34-P1.0	L5-P1.0	TA0CLK	TACLK	Timer	NA	NA		
		ACLK	ACLK					
		SMCLK	SMCLK					
34-P1.0	L5-P1.0	TA0CLK	$\overline{\text{TACLK}}$	CCR0	TA0	TA0.0		
35-P1.1	M5-P1.1	TA0.0	CCI0A				35-P1.1	M5-P1.1
		DV <sub>SS</sub>	CCI0B					
		DV <sub>SS</sub>	GND					
		DV <sub>CC</sub>	V <sub>CC</sub>					
36-P1.2	J6-P1.2	TA0.1	CCI1A	CCR1	TA1	TA0.1	36-P1.2	J6-P1.2
40-P1.6	J7-P1.6	TA0.1	CCI1B				40-P1.6	J7-P1.6
		DV <sub>SS</sub>	GND				ADC12_A (internal) ADC12SHSx = {1}	
		DV <sub>CC</sub>	V <sub>CC</sub>					
37-P1.3	H6-P1.3	TA0.2	CCI2A	CCR2	TA2	TA0.2	37-P1.3	H6-P1.3
41-P1.7	M7-P1.7	TA0.2	CCI2B				41-P1.7	M7-P1.7
		DV <sub>SS</sub>	GND					
		DV <sub>CC</sub>	V <sub>CC</sub>					
38-P1.4	M6-P1.4	TA0.3	CCI3A	CCR3	TA3	TA0.3	38-P1.4	M6-P1.4
		DV <sub>SS</sub>	CCI3B					
		DV <sub>SS</sub>	GND					
		DV <sub>CC</sub>	V <sub>CC</sub>					
39-P1.5	L6-P1.5	TA0.4	CCI4A	CCR4	TA4	TA0.4	39-P1.5	L6-P1.5
		DV <sub>SS</sub>	CCI4B					
		DV <sub>SS</sub>	GND					
		DV <sub>CC</sub>	V <sub>CC</sub>					

### 6.12.12 Timer TA1 [\(Link to User's Guide\)](#)

Timer TA1 is a 16-bit timer/counter (Timer\_A type) with three capture/compare registers. TA1 supports multiple capture/comparators, PWM outputs, and interval timing (see [Table 6-15](#)). TA1 also has extensive interrupt capabilities. Interrupts may be generated from the counter on overflow conditions and from each of the capture/compare registers.

**Table 6-15. Timer TA1 Signal Connections**

INPUT PIN NUMBER		DEVICE INPUT SIGNAL	MODULE INPUT SIGNAL	MODULE BLOCK	MODULE OUTPUT SIGNAL	DEVICE OUTPUT SIGNAL	OUTPUT PIN NUMBER	
PZ	ZQW						PZ	ZQW
42-P3.0	L7-P3.0	TA1CLK	TACLK	Timer	NA	NA		
		ACLK	ACLK					
		SMCLK	SMCLK					
42-P3.0	L7-P3.0	TA1CLK	$\overline{\text{TACLK}}$					
43-P3.1	H7-P3.1	TA1.0	CCI0A	CCR0	TA0	TA1.0	43-P3.1	H7-P3.1
		DV <sub>SS</sub>	CCI0B					
		DV <sub>SS</sub>	GND					
		DV <sub>CC</sub>	V <sub>CC</sub>					
44-P3.2	M8-P3.2	TA1.1	CCI1A	CCR1	TA1	TA1.1	44-P3.2	M8-P3.2
		CBOUT (internal)	CCI1B				DAC12_A DAC12_0, DAC12_1 (internal)	
		DV <sub>SS</sub>	GND					
		DV <sub>CC</sub>	V <sub>CC</sub>					
45-P3.3	L8-P3.3	TA1.2	CCI2A	CCR2	TA2	TA1.2	45-P3.3	L8-P3.3
		ACLK (internal)	CCI2B					
		DV <sub>SS</sub>	GND					
		DV <sub>CC</sub>	V <sub>CC</sub>					

### 6.12.13 Timer TA2 ([Link to User's Guide](#))

Timer TA2 is a 16-bit timer/counter (Timer\_A type) with three capture/compare registers. TA2 supports multiple capture/compares, PWM outputs, and interval timing (see [Table 6-16](#)). TA2 also has extensive interrupt capabilities. Interrupts may be generated from the counter on overflow conditions and from each of the capture/compare registers.

**Table 6-16. Timer TA2 Signal Connections**

INPUT PIN NUMBER		DEVICE INPUT SIGNAL	MODULE INPUT SIGNAL	MODULE BLOCK	MODULE OUTPUT SIGNAL	DEVICE OUTPUT SIGNAL	OUTPUT PIN NUMBER	
PZ	ZQW						PZ	ZQW
46-P3.4	J8-P3.4	TA2CLK	TACLK	Timer	NA	NA		
		ACLK	ACLK					
		SMCLK	SMCLK					
46-P3.4	J8-P3.4	TA2CLK	$\overline{\text{TACLK}}$	CCR0	TA0	TA2.0		
47-P3.5	M9-P3.5	TA2.0	CCI0A				47-P3.5	M9-P3.5
		DV <sub>SS</sub>	CCI0B					
		DV <sub>SS</sub>	GND					
		DV <sub>CC</sub>	V <sub>CC</sub>					
48-P3.6	L9-P3.6	TA2.1	CCI1A	CCR1	TA1	TA2.1	48-P3.6	L9-P3.6
		CBOUT (internal)	CCI1B					
		DV <sub>SS</sub>	GND					
		DV <sub>CC</sub>	V <sub>CC</sub>					
49-P3.7	M10-P3.7	TA2.2	CCI2A	CCR2	TA2	TA2.2	49-P3.7	M10-P3.7
		ACLK (internal)	CCI2B					
		DV <sub>SS</sub>	GND					
		DV <sub>CC</sub>	V <sub>CC</sub>					

### 6.12.14 Timer TB0 (Link to User's Guide)

Timer TB0 is a 16-bit timer/counter (Timer\_B type) with seven capture/compare registers. TB0 supports multiple capture/comparers, PWM outputs, and interval timing (see Table 6-17). TB0 also has extensive interrupt capabilities. Interrupts may be generated from the counter on overflow conditions and from each of the capture/compare registers.

Table 6-17. Timer TB0 Signal Connections

INPUT PIN NUMBER		DEVICE INPUT SIGNAL	MODULE INPUT SIGNAL	MODULE BLOCK	MODULE OUTPUT SIGNAL	DEVICE OUTPUT SIGNAL	OUTPUT PIN NUMBER	
PZ	ZQW						PZ	ZQW
58-P8.0 P2MAPx <sup>(1)</sup>	J11-P8.0 P2MAPx <sup>(1)</sup>	TB0CLK	TB0CLK	Timer	NA	NA		
		ACLK	ACLK					
		SMCLK	SMCLK					
58-P8.0 P2MAPx <sup>(1)</sup>	J11-P8.0 P2MAPx <sup>(1)</sup>	TB0CLK	$\overline{\text{TB0CLK}}$					
50-P4.0 P2MAPx <sup>(1)</sup>	J9-P4.0 P2MAPx <sup>(1)</sup>	TB0.0	CCI0A	CCR0	TB0	TB0.0	50-P4.0	J9-P4.0
		TB0.0	CCI0B				P2MAPx <sup>(1)</sup>	P2MAPx <sup>(1)</sup>
		DV <sub>SS</sub>	GND				ADC12 (internal) ADC12SHSx = {2}	
		DV <sub>CC</sub>	V <sub>CC</sub>					
51-P4.1 P2MAPx <sup>(1)</sup>	M11-P4.1 P2MAPx <sup>(1)</sup>	TB0.1	CCI1A	CCR1	TB1	TB0.1	51-P4.1	M11-P4.1
		TB0.1	CCI1B				P2MAPx <sup>(1)</sup>	P2MAPx <sup>(1)</sup>
		DV <sub>SS</sub>	GND				ADC12 (internal) ADC12SHSx = {3}	
		DV <sub>CC</sub>	V <sub>CC</sub>					
52-P4.2 P2MAPx <sup>(1)</sup>	L10-P4.2 P2MAPx <sup>(1)</sup>	TB0.2	CCI2A	CCR2	TB2	TB0.2	52-P4.2	L10-P4.2
		TB0.2	CCI2B				P2MAPx <sup>(1)</sup>	P2MAPx <sup>(1)</sup>
		DV <sub>SS</sub>	GND				DAC12_A DAC12_0, DAC12_1 (internal)	
		DV <sub>CC</sub>	V <sub>CC</sub>					
53-P4.3 P2MAPx <sup>(1)</sup>	M12-P4.3 P2MAPx <sup>(1)</sup>	TB0.3	CCI3A	CCR3	TB3	TB0.3	53-P4.3	M12-P4.3
		TB0.3	CCI3B				P2MAPx <sup>(1)</sup>	P2MAPx <sup>(1)</sup>
		DV <sub>SS</sub>	GND					
		DV <sub>CC</sub>	V <sub>CC</sub>					
54-P4.4 P2MAPx <sup>(1)</sup>	L12-P4.4 P2MAPx <sup>(1)</sup>	TB0.4	CCI4A	CCR4	TB4	TB0.4	54-P4.4	L12-P4.4
		TB0.4	CCI4B				P2MAPx <sup>(1)</sup>	P2MAPx <sup>(1)</sup>
		DV <sub>SS</sub>	GND					
		DV <sub>CC</sub>	V <sub>CC</sub>					
55-P4.5 P2MAPx <sup>(1)</sup>	L11-P4.5 P2MAPx <sup>(1)</sup>	TB0.5	CCI5A	CCR5	TB5	TB0.5	55-P4.5	L11-P4.5
		TB0.5	CCI5B				P2MAPx <sup>(1)</sup>	P2MAPx <sup>(1)</sup>
		DV <sub>SS</sub>	GND					
		DV <sub>CC</sub>	V <sub>CC</sub>					
56-P4.6 P2MAPx <sup>(1)</sup>	K11-P4.6 P2MAPx <sup>(1)</sup>	TB0.6	CCI6A	CCR6	TB6	TB0.6	56-P4.6	K11-P4.6
		TB0.6	CCI6B				P2MAPx <sup>(1)</sup>	P2MAPx <sup>(1)</sup>
		DV <sub>SS</sub>	GND					
		DV <sub>CC</sub>	V <sub>CC</sub>					

(1) Timer functions are selectable through the port mapping controller.

### 6.12.15 **Comparator\_B** ([Link to User's Guide](#))

The primary function of the Comparator\_B module is to support precision slope analog-to-digital conversions, battery voltage supervision, and monitoring of external analog signals.

### 6.12.16 **ADC12\_A** ([Link to User's Guide](#))

The ADC12\_A module supports fast 12-bit analog-to-digital conversions. The module implements a 12-bit SAR core, sample select control, reference generator, and a 16 word conversion-and-control buffer. The conversion-and-control buffer allows up to 16 independent ADC samples to be converted and stored without any CPU intervention.

### 6.12.17 **DAC12\_A** ([Link to User's Guide](#))

The DAC12\_A module is a 12-bit R-ladder voltage-output DAC. The DAC12\_A may be used in 8-bit or 12-bit mode, and may be used in conjunction with the DMA controller. When multiple DAC12\_A modules are present, they may be grouped together for synchronous operation.

### 6.12.18 **CRC16** ([Link to User's Guide](#))

The CRC16 module produces a signature based on a sequence of entered data values and can be used for data checking purposes. The CRC16 module signature is based on the CRC-CCITT standard.

### 6.12.19 **Voltage Reference (REF) Module** ([Link to User's Guide](#))

The REF module generates all critical reference voltages that can be used by the various analog peripherals in the device.

### 6.12.20 **LCD\_B** ([Link to User's Guide](#))

The LCD\_B driver generates the segment and common signals that are required to drive a liquid crystal display (LCD). The LCD\_B controller has dedicated data memories to hold segment drive information. Common and segment signals are generated as defined by the mode. Static, 2-mux, 3-mux, and 4-mux LCDs are supported. The module can provide a LCD voltage independent of the supply voltage with its integrated charge pump. It is possible to control the level of the LCD voltage, and thus contrast, by software. The module also provides an automatic blinking capability for individual segments.

The LCD\_B module is available only on the MSP430F665x and MSP430F645x devices.

### 6.12.21 **USB Universal Serial Bus** ([Link to User's Guide](#))

The USB module is a fully integrated USB interface that is compliant with the USB 2.0 specification. The module supports full-speed operation of control, interrupt, and bulk transfers. The module includes an integrated LDO, PHY, and PLL. The PLL is highly flexible and supports a wide range of input clock frequencies. When USB RAM is not used for USB communication, it can be used by the system.

The USB module is available only on the MSP430F665x and MSP430F565x devices.

### 6.12.22 **LDO and PU Port**

The integrated 3.3-V power system incorporates an integrated 3.3-V LDO regulator that allows the entire MSP430 microcontroller to be powered from nominal 5-V LDO when it is made available for the system. Alternatively, the power system can supply power only to other components within the system, or it can be unused altogether.

The Port U Pins (PU.0 and PU.1) function as general-purpose high-current I/O pins. These pins can only be configured together as either both inputs or both outputs. Port U is supplied by the LDO rail. If the 3.3-V LDO is not being used in the system (disabled), the LDO pin can be supplied externally.

The LDO-PWR module (LDO and PU Port) is available on only the MSP430F645x and MSP430F535x devices.

### 6.12.23 Embedded Emulation Module (EEM) (L Version) [\(Link to User's Guide\)](#)

The EEM supports real-time in-system debugging. The L version of the EEM has the following features:

- Eight hardware triggers or breakpoints on memory access
- Two hardware triggers or breakpoints on CPU register write access
- Up to 10 hardware triggers can be combined to form complex triggers or breakpoints
- Two cycle counters
- Sequencer
- State storage
- Clock control on module level

### 6.12.24 Peripheral File Map

Table 6-18 lists the base register address for each available peripheral.

**Table 6-18. Peripherals**

MODULE NAME	BASE ADDRESS	OFFSET ADDRESS RANGE <sup>(1)</sup>
Special Functions (see <a href="#">Table 6-19</a> )	0100h	000h to 01Fh
PMM (see <a href="#">Table 6-20</a> )	0120h	000h to 010h
Flash Control (see <a href="#">Table 6-21</a> )	0140h	000h to 00Fh
CRC16 (see <a href="#">Table 6-22</a> )	0150h	000h to 007h
RAM Control (see <a href="#">Table 6-23</a> )	0158h	000h to 001h
Watchdog (see <a href="#">Table 6-24</a> )	015Ch	000h to 001h
UCS (see <a href="#">Table 6-25</a> )	0160h	000h to 01Fh
SYS (see <a href="#">Table 6-26</a> )	0180h	000h to 01Fh
Shared Reference (see <a href="#">Table 6-27</a> )	01B0h	000h to 001h
Port Mapping Control (see <a href="#">Table 6-28</a> )	01C0h	000h to 003h
Port Mapping Port P2 (see <a href="#">Table 6-28</a> )	01D0h	000h to 007h
Port P1, P2 (see <a href="#">Table 6-29</a> )	0200h	000h to 01Fh
Port P3, P4 (see <a href="#">Table 6-30</a> )	0220h	000h to 01Fh
Port P5, P6 (see <a href="#">Table 6-31</a> )	0240h	000h to 00Bh
Port P7, P8 (see <a href="#">Table 6-32</a> )	0260h	000h to 00Bh
Port P9 (see <a href="#">Table 6-33</a> )	0280h	000h to 00Bh
Port PJ (see <a href="#">Table 6-34</a> )	0320h	000h to 01Fh
Timer TA0 (see <a href="#">Table 6-35</a> )	0340h	000h to 02Eh
Timer TA1 (see <a href="#">Table 6-36</a> )	0380h	000h to 02Eh
Timer TB0 (see <a href="#">Table 6-37</a> )	03C0h	000h to 02Eh
Timer TA2 (see <a href="#">Table 6-38</a> )	0400h	000h to 02Eh
Battery Backup (see <a href="#">Table 6-39</a> )	0480h	000h to 01Fh
RTC_B (see <a href="#">Table 6-40</a> )	04A0h	000h to 01Fh
32-Bit Hardware Multiplier (see <a href="#">Table 6-41</a> )	04C0h	000h to 02Fh
DMA General Control (see <a href="#">Table 6-42</a> )	0500h	000h to 00Fh
DMA Channel 0 (see <a href="#">Table 6-42</a> )	0510h	000h to 00Ah
DMA Channel 1 (see <a href="#">Table 6-42</a> )	0520h	000h to 00Ah
DMA Channel 2 (see <a href="#">Table 6-42</a> )	0530h	000h to 00Ah
DMA Channel 3 (see <a href="#">Table 6-42</a> )	0540h	000h to 00Ah
DMA Channel 4 (see <a href="#">Table 6-42</a> )	0550h	000h to 00Ah
DMA Channel 5 (see <a href="#">Table 6-42</a> )	0560h	000h to 00Ah
USCI_A0 (see <a href="#">Table 6-43</a> )	05C0h	000h to 01Fh

(1) For a detailed description of the individual control register offset addresses, see the [MSP430F5xx and MSP430F6xx Family User's Guide](#).

**Table 6-18. Peripherals (continued)**

MODULE NAME	BASE ADDRESS	OFFSET ADDRESS RANGE <sup>(1)</sup>
USCI_B0 (see <a href="#">Table 6-44</a> )	05E0h	000h to 01Fh
USCI_A1 (see <a href="#">Table 6-45</a> )	0600h	000h to 01Fh
USCI_B1 (see <a href="#">Table 6-46</a> )	0620h	000h to 01Fh
USCI_A2 (see <a href="#">Table 6-47</a> )	0640h	000h to 01Fh
USCI_B2 (see <a href="#">Table 6-48</a> )	0660h	000h to 01Fh
ADC12_A (see <a href="#">Table 6-49</a> )	0700h	000h to 03Fh
DAC12_A (see <a href="#">Table 6-50</a> )	0780h	000h to 01Fh
Comparator_B (see <a href="#">Table 6-51</a> )	08C0h	000h to 00Fh
USB configuration (see <a href="#">Table 6-52</a> ) <sup>(2)</sup>	0900h	000h to 014h
USB control (see <a href="#">Table 6-53</a> ) <sup>(2)</sup>	0920h	000h to 01Fh
LDO-PWR; LDO and Port U configuration (see <a href="#">Table 6-54</a> ) <sup>(3)</sup>	0900h	000h to 014h
LCD_B control (see <a href="#">Table 6-55</a> ) <sup>(4)</sup>	0A00h	000h to 05Fh

- (2) Only on devices with peripheral module USB.  
 (3) Only on devices with peripheral module LDO-PWR.  
 (4) Only on devices with peripheral module LCD\_B.

**Table 6-19. Special Function Registers (Base Address: 0100h)**

REGISTER DESCRIPTION	REGISTER	OFFSET
SFR interrupt enable	SFRIE1	00h
SFR interrupt flag	SFRIFG1	02h
SFR reset pin control	SFRRPCR	04h

**Table 6-20. PMM Registers (Base Address: 0120h)**

REGISTER DESCRIPTION	REGISTER	OFFSET
PMM control 0	PMMCTL0	00h
PMM control 1	PMMCTL1	02h
SVS high-side control	SVSMHCTL	04h
SVS low-side control	SVSMLCTL	06h
PMM interrupt flags	PMMIFG	0Ch
PMM interrupt enable	PMMIE	0Eh
PMM power mode 5 control	PM5CTL0	10h

**Table 6-21. Flash Control Registers (Base Address: 0140h)**

REGISTER DESCRIPTION	REGISTER	OFFSET
Flash control 1	FCTL1	00h
Flash control 3	FCTL3	04h
Flash control 4	FCTL4	06h

**Table 6-22. CRC16 Registers (Base Address: 0150h)**

REGISTER DESCRIPTION	REGISTER	OFFSET
CRC data input	CRC16DI	00h
CRC result	CRC16INIRES	04h

**Table 6-23. RAM Control Registers (Base Address: 0158h)**

REGISTER DESCRIPTION	REGISTER	OFFSET
RAM control 0	RCCTL0	00h

**Table 6-24. Watchdog Registers (Base Address: 015Ch)**

REGISTER DESCRIPTION	REGISTER	OFFSET
Watchdog timer control	WDTCTL	00h

**Table 6-25. UCS Registers (Base Address: 0160h)**

REGISTER DESCRIPTION	REGISTER	OFFSET
UCS control 0	UCSCTL0	00h
UCS control 1	UCSCTL1	02h
UCS control 2	UCSCTL2	04h
UCS control 3	UCSCTL3	06h
UCS control 4	UCSCTL4	08h
UCS control 5	UCSCTL5	0Ah
UCS control 6	UCSCTL6	0Ch
UCS control 7	UCSCTL7	0Eh
UCS control 8	UCSCTL8	10h

**Table 6-26. SYS Registers (Base Address: 0180h)**

REGISTER DESCRIPTION	REGISTER	OFFSET
System control	SYSCTL	00h
Bootloader configuration area	SYSBSLC	02h
JTAG mailbox control	SYSJMBC	06h
JTAG mailbox input 0	SYSJMBIO	08h
JTAG mailbox input 1	SYSJMBI1	0Ah
JTAG mailbox output 0	SYSJMBO0	0Ch
JTAG mailbox output 1	SYSJMBO1	0Eh
Bus error vector generator	SYSBERRIV	18h
User NMI vector generator	SYSUNIV	1Ah
System NMI vector generator	SYSSNIV	1Ch
Reset vector generator	SYSRSTIV	1Eh

**Table 6-27. Shared Reference Registers (Base Address: 01B0h)**

REGISTER DESCRIPTION	REGISTER	OFFSET
Shared reference control	REFCTL	00h

**Table 6-28. Port Mapping Registers  
(Base Address of Port Mapping Control: 01C0h, Port P4: 01D0h)**

REGISTER DESCRIPTION	REGISTER	OFFSET
Port mapping password	PMAPPWD	00h
Port mapping control	PMAPCTL	02h
Port P2.0 mapping	P2MAP0	00h
Port P2.1 mapping	P2MAP1	01h
Port P2.2 mapping	P2MAP2	02h
Port P2.3 mapping	P2MAP3	03h
Port P2.4 mapping	P2MAP4	04h
Port P2.5 mapping	P2MAP5	05h
Port P2.6 mapping	P2MAP6	06h
Port P2.7 mapping	P2MAP7	07h

**Table 6-29. Port P1, P2 Registers (Base Address: 0200h)**

REGISTER DESCRIPTION	REGISTER	OFFSET
Port P1 input	P1IN	00h
Port P1 output	P1OUT	02h
Port P1 direction	P1DIR	04h
Port P1 resistor enable	P1REN	06h
Port P1 drive strength	P1DS	08h
Port P1 selection	P1SEL	0Ah
Port P1 interrupt vector word	P1IV	0Eh
Port P1 interrupt edge select	P1IES	18h
Port P1 interrupt enable	P1IE	1Ah
Port P1 interrupt flag	P1IFG	1Ch
Port P2 input	P2IN	01h
Port P2 output	P2OUT	03h
Port P2 direction	P2DIR	05h
Port P2 resistor enable	P2REN	07h

**Table 6-29. Port P1, P2 Registers (Base Address: 0200h) (continued)**

REGISTER DESCRIPTION	REGISTER	OFFSET
Port P2 drive strength	P2DS	09h
Port P2 selection	P2SEL	0Bh
Port P2 interrupt vector word	P2IV	1Eh
Port P2 interrupt edge select	P2IES	19h
Port P2 interrupt enable	P2IE	1Bh
Port P2 interrupt flag	P2IFG	1Dh

**Table 6-30. Port P3, P4 Registers (Base Address: 0220h)**

REGISTER DESCRIPTION	REGISTER	OFFSET
Port P3 input	P3IN	00h
Port P3 output	P3OUT	02h
Port P3 direction	P3DIR	04h
Port P3 resistor enable	P3REN	06h
Port P3 drive strength	P3DS	08h
Port P3 selection	P3SEL	0Ah
Port P3 interrupt vector word	P3IV	0Eh
Port P3 interrupt edge select	P3IES	18h
Port P3 interrupt enable	P3IE	1Ah
Port P3 interrupt flag	P3IFG	1Ch
Port P4 input	P4IN	01h
Port P4 output	P4OUT	03h
Port P4 direction	P4DIR	05h
Port P4 resistor enable	P4REN	07h
Port P4 drive strength	P4DS	09h
Port P4 selection	P4SEL	0Bh
Port P4 interrupt vector word	P4IV	1Eh
Port P4 interrupt edge select	P4IES	19h
Port P4 interrupt enable	P4IE	1Bh
Port P4 interrupt flag	P4IFG	1Dh

**Table 6-31. Port P5, P6 Registers (Base Address: 0240h)**

REGISTER DESCRIPTION	REGISTER	OFFSET
Port P5 input	P5IN	00h
Port P5 output	P5OUT	02h
Port P5 direction	P5DIR	04h
Port P5 resistor enable	P5REN	06h
Port P5 drive strength	P5DS	08h
Port P5 selection	P5SEL	0Ah
Port P6 input	P6IN	01h
Port P6 output	P6OUT	03h
Port P6 direction	P6DIR	05h
Port P6 resistor enable	P6REN	07h
Port P6 drive strength	P6DS	09h
Port P6 selection	P6SEL	0Bh

**Table 6-32. Port P7, P8 Registers (Base Address: 0260h)**

REGISTER DESCRIPTION	REGISTER	OFFSET
Port P7 input	P7IN	00h
Port P7 output	P7OUT	02h
Port P7 direction	P7DIR	04h
Port P7 resistor enable	P7REN	06h
Port P7 drive strength	P7DS	08h
Port P7 selection	P7SEL	0Ah
Port P8 input	P8IN	01h
Port P8 output	P8OUT	03h
Port P8 direction	P8DIR	05h
Port P8 resistor enable	P8REN	07h
Port P8 drive strength	P8DS	09h
Port P8 selection	P8SEL	0Bh

**Table 6-33. Port P9 Register (Base Address: 0280h)**

REGISTER DESCRIPTION	REGISTER	OFFSET
Port P9 input	P9IN	00h
Port P9 output	P9OUT	02h
Port P9 direction	P9DIR	04h
Port P9 resistor enable	P9REN	06h
Port P9 drive strength	P9DS	08h
Port P9 selection	P9SEL	0Ah

**Table 6-34. Port J Registers (Base Address: 0320h)**

REGISTER DESCRIPTION	REGISTER	OFFSET
Port PJ input	PJIN	00h
Port PJ output	PJOUT	02h
Port PJ direction	PJDIR	04h
Port PJ resistor enable	PJREN	06h
Port PJ drive strength	PJDS	08h

**Table 6-35. TA0 Registers (Base Address: 0340h)**

REGISTER DESCRIPTION	REGISTER	OFFSET
TA0 control	TA0CTL	00h
Capture/compare control 0	TA0CCTL0	02h
Capture/compare control 1	TA0CCTL1	04h
Capture/compare control 2	TA0CCTL2	06h
Capture/compare control 3	TA0CCTL3	08h
Capture/compare control 4	TA0CCTL4	0Ah
TA0 counter	TA0R	10h
Capture/compare 0	TA0CCR0	12h
Capture/compare 1	TA0CCR1	14h
Capture/compare 2	TA0CCR2	16h
Capture/compare 3	TA0CCR3	18h
Capture/compare 4	TA0CCR4	1Ah
TA0 expansion 0	TA0EX0	20h
TA0 interrupt vector	TA0IV	2Eh

**Table 6-36. TA1 Registers (Base Address: 0380h)**

REGISTER DESCRIPTION	REGISTER	OFFSET
TA1 control	TA1CTL	00h
Capture/compare control 0	TA1CCTL0	02h
Capture/compare control 1	TA1CCTL1	04h
Capture/compare control 2	TA1CCTL2	06h
TA1 counter	TA1R	10h
Capture/compare 0	TA1CCR0	12h
Capture/compare 1	TA1CCR1	14h
Capture/compare 2	TA1CCR2	16h
TA1 expansion 0	TA1EX0	20h
TA1 interrupt vector	TA1IV	2Eh

**Table 6-37. TB0 Registers (Base Address: 03C0h)**

REGISTER DESCRIPTION	REGISTER	OFFSET
TB0 control	TB0CTL	00h
Capture/compare control 0	TB0CCTL0	02h
Capture/compare control 1	TB0CCTL1	04h
Capture/compare control 2	TB0CCTL2	06h
Capture/compare control 3	TB0CCTL3	08h
Capture/compare control 4	TB0CCTL4	0Ah
Capture/compare control 5	TB0CCTL5	0Ch
Capture/compare control 6	TB0CCTL6	0Eh
TB0 counter	TB0R	10h
Capture/compare 0	TB0CCR0	12h
Capture/compare 1	TB0CCR1	14h
Capture/compare 2	TB0CCR2	16h
Capture/compare 3	TB0CCR3	18h
Capture/compare 4	TB0CCR4	1Ah
Capture/compare 5	TB0CCR5	1Ch
Capture/compare 6	TB0CCR6	1Eh
TB0 expansion 0	TB0EX0	20h
TB0 interrupt vector	TB0IV	2Eh

**Table 6-38. TA2 Registers (Base Address: 0400h)**

REGISTER DESCRIPTION	REGISTER	OFFSET
TA2 control	TA2CTL	00h
Capture/compare control 0	TA2CCTL0	02h
Capture/compare control 1	TA2CCTL1	04h
Capture/compare control 2	TA2CCTL2	06h
TA2 counter	TA2R	10h
Capture/compare 0	TA2CCR0	12h
Capture/compare 1	TA2CCR1	14h
Capture/compare 2	TA2CCR2	16h
TA2 expansion 0	TA2EX0	20h
TA2 interrupt vector	TA2IV	2Eh

**Table 6-39. Battery Backup Registers (Base Address: 0480h)**

REGISTER DESCRIPTION	REGISTER	OFFSET
Battery backup memory 0	BAKMEM0	00h
Battery backup memory 1	BAKMEM1	02h
Battery backup memory 2	BAKMEM2	04h
Battery backup memory 3	BAKMEM3	06h
Battery backup control	BAKCTL	1Ch
Battery charger control	BAKCHCTL	1Eh

**Table 6-40. Real-Time Clock Registers (Base Address: 04A0h)**

REGISTER DESCRIPTION	REGISTER	OFFSET
RTC control 0	RTCCTL0	00h
RTC control 1	RTCCTL1	01h
RTC control 2	RTCCTL2	02h
RTC control 3	RTCCTL3	03h
RTC prescaler 0 control	RTCPS0CTL	08h
RTC prescaler 1 control	RTCPS1CTL	0Ah
RTC prescaler 0	RTCPS0	0Ch
RTC prescaler 1	RTCPS1	0Dh
RTC interrupt vector word	RTCIV	0Eh
RTC seconds	RTCSEC	10h
RTC minutes	RTCMIN	11h
RTC hours	RTCHOUR	12h
RTC day of week	RTCDOW	13h
RTC days	RTCDAY	14h
RTC month	RTCMON	15h
RTC year low	RTCYEARL	16h
RTC year high	RTCYEARH	17h
RTC alarm minutes	RTCAMIN	18h
RTC alarm hours	RTCAHOUR	19h
RTC alarm day of week	RTCADOW	1Ah
RTC alarm days	RTCADAY	1Bh
Binary-to-BCD conversion	BIN2BCD	1Ch
BCD-to-binary conversion	BCD2BIN	1Eh

**Table 6-41. 32-Bit Hardware Multiplier Registers (Base Address: 04C0h)**

REGISTER DESCRIPTION	REGISTER	OFFSET
16-bit operand 1 – multiply	MPY	00h
16-bit operand 1 – signed multiply	MPYS	02h
16-bit operand 1 – multiply accumulate	MAC	04h
16-bit operand 1 – signed multiply accumulate	MACS	06h
16-bit operand 2	OP2	08h
16 × 16 result low word	RESLO	0Ah
16 × 16 result high word	RESHI	0Ch
16 × 16 sum extension	SUMEXT	0Eh
32-bit operand 1 – multiply low word	MPY32L	10h
32-bit operand 1 – multiply high word	MPY32H	12h
32-bit operand 1 – signed multiply low word	MPYS32L	14h
32-bit operand 1 – signed multiply high word	MPYS32H	16h

**Table 6-41. 32-Bit Hardware Multiplier Registers (Base Address: 04C0h) (continued)**

REGISTER DESCRIPTION	REGISTER	OFFSET
32-bit operand 1 – multiply accumulate low word	MAC32L	18h
32-bit operand 1 – multiply accumulate high word	MAC32H	1Ah
32-bit operand 1 – signed multiply accumulate low word	MACS32L	1Ch
32-bit operand 1 – signed multiply accumulate high word	MACS32H	1Eh
32-bit operand 2 – low word	OP2L	20h
32-bit operand 2 – high word	OP2H	22h
32 × 32 result 0 – least significant word	RES0	24h
32 × 32 result 1	RES1	26h
32 × 32 result 2	RES2	28h
32 × 32 result 3 – most significant word	RES3	2Ah
MPY32 control 0	MPY32CTL0	2Ch

**Table 6-42. DMA Registers (Base Address DMA General Control: 0500h, DMA Channel 0: 0510h, DMA Channel 1: 0520h, DMA Channel 2: 0530h, DMA Channel 3: 0540h, DMA Channel 4: 0550h, DMA Channel 5: 0560h)**

REGISTER DESCRIPTION	REGISTER	OFFSET
DMA general control: DMA module control 0	DMACTL0	00h
DMA general control: DMA module control 1	DMACTL1	02h
DMA general control: DMA module control 2	DMACTL2	04h
DMA general control: DMA module control 3	DMACTL3	06h
DMA general control: DMA module control 4	DMACTL4	08h
DMA general control: DMA interrupt vector	DMAIV	0Ah
DMA channel 0 control	DMA0CTL	00h
DMA channel 0 source address low	DMA0SAL	02h
DMA channel 0 source address high	DMA0SAH	04h
DMA channel 0 destination address low	DMA0DAL	06h
DMA channel 0 destination address high	DMA0DAH	08h
DMA channel 0 transfer size	DMA0SZ	0Ah
DMA channel 1 control	DMA1CTL	00h
DMA channel 1 source address low	DMA1SAL	02h
DMA channel 1 source address high	DMA1SAH	04h
DMA channel 1 destination address low	DMA1DAL	06h
DMA channel 1 destination address high	DMA1DAH	08h
DMA channel 1 transfer size	DMA1SZ	0Ah
DMA channel 2 control	DMA2CTL	00h
DMA channel 2 source address low	DMA2SAL	02h
DMA channel 2 source address high	DMA2SAH	04h
DMA channel 2 destination address low	DMA2DAL	06h
DMA channel 2 destination address high	DMA2DAH	08h
DMA channel 2 transfer size	DMA2SZ	0Ah
DMA channel 3 control	DMA3CTL	00h
DMA channel 3 source address low	DMA3SAL	02h
DMA channel 3 source address high	DMA3SAH	04h
DMA channel 3 destination address low	DMA3DAL	06h
DMA channel 3 destination address high	DMA3DAH	08h
DMA channel 3 transfer size	DMA3SZ	0Ah
DMA channel 4 control	DMA4CTL	00h

**Table 6-42. DMA Registers (Base Address DMA General Control: 0500h, DMA Channel 0: 0510h, DMA Channel 1: 0520h, DMA Channel 2: 0530h, DMA Channel 3: 0540h, DMA Channel 4: 0550h, DMA Channel 5: 0560h) (continued)**

REGISTER DESCRIPTION	REGISTER	OFFSET
DMA channel 4 source address low	DMA4SAL	02h
DMA channel 4 source address high	DMA4SAH	04h
DMA channel 4 destination address low	DMA4DAL	06h
DMA channel 4 destination address high	DMA4DAH	08h
DMA channel 4 transfer size	DMA4SZ	0Ah
DMA channel 5 control	DMA5CTL	00h
DMA channel 5 source address low	DMA5SAL	02h
DMA channel 5 source address high	DMA5SAH	04h
DMA channel 5 destination address low	DMA5DAL	06h
DMA channel 5 destination address high	DMA5DAH	08h
DMA channel 5 transfer size	DMA5SZ	0Ah

**Table 6-43. USCI\_A0 Registers (Base Address: 05C0h)**

REGISTER DESCRIPTION	REGISTER	OFFSET
USCI control 0	UCA0CTL0	00h
USCI control 1	UCA0CTL1	01h
USCI baud rate 0	UCA0BR0	06h
USCI baud rate 1	UCA0BR1	07h
USCI modulation control	UCA0MCTL	08h
USCI status	UCA0STAT	0Ah
USCI receive buffer	UCA0RXBUF	0Ch
USCI transmit buffer	UCA0TXBUF	0Eh
USCI LIN control	UCA0ABCTL	10h
USCI IrDA transmit control	UCA0IRTCTL	12h
USCI IrDA receive control	UCA0IRRCTL	13h
USCI interrupt enable	UCA0IE	1Ch
USCI interrupt flags	UCA0IFG	1Dh
USCI interrupt vector word	UCA0IV	1Eh

**Table 6-44. USCI\_B0 Registers (Base Address: 05E0h)**

REGISTER DESCRIPTION	REGISTER	OFFSET
USCI synchronous control 0	UCB0CTL0	00h
USCI synchronous control 1	UCB0CTL1	01h
USCI synchronous bit rate 0	UCB0BR0	06h
USCI synchronous bit rate 1	UCB0BR1	07h
USCI synchronous status	UCB0STAT	0Ah
USCI synchronous receive buffer	UCB0RXBUF	0Ch
USCI synchronous transmit buffer	UCB0TXBUF	0Eh
USCI I2C own address	UCB0I2COA	10h
USCI I2C slave address	UCB0I2CSA	12h
USCI interrupt enable	UCB0IE	1Ch
USCI interrupt flags	UCB0IFG	1Dh
USCI interrupt vector word	UCB0IV	1Eh

**Table 6-45. USCI\_A1 Registers (Base Address: 0600h)**

REGISTER DESCRIPTION	REGISTER	OFFSET
USCI control 0	UCA1CTL0	00h
USCI control 1	UCA1CTL1	01h
USCI baud rate 0	UCA1BR0	06h
USCI baud rate 1	UCA1BR1	07h
USCI modulation control	UCA1MCTL	08h
USCI status	UCA1STAT	0Ah
USCI receive buffer	UCA1RXBUF	0Ch
USCI transmit buffer	UCA1TXBUF	0Eh
USCI LIN control	UCA1ABCTL	10h
USCI IrDA transmit control	UCA1IRTCTL	12h
USCI IrDA receive control	UCA1IRRCTL	13h
USCI interrupt enable	UCA1IE	1Ch
USCI interrupt flags	UCA1IFG	1Dh
USCI interrupt vector word	UCA1IV	1Eh

**Table 6-46. USCI\_B1 Registers (Base Address: 0620h)**

REGISTER DESCRIPTION	REGISTER	OFFSET
USCI synchronous control 0	UCB1CTL0	00h
USCI synchronous control 1	UCB1CTL1	01h
USCI synchronous bit rate 0	UCB1BR0	06h
USCI synchronous bit rate 1	UCB1BR1	07h
USCI synchronous status	UCB1STAT	0Ah
USCI synchronous receive buffer	UCB1RXBUF	0Ch
USCI synchronous transmit buffer	UCB1TXBUF	0Eh
USCI I2C own address	UCB1I2COA	10h
USCI I2C slave address	UCB1I2CSA	12h
USCI interrupt enable	UCB1IE	1Ch
USCI interrupt flags	UCB1IFG	1Dh
USCI interrupt vector word	UCB1IV	1Eh

**Table 6-47. USCI\_A2 Registers (Base Address: 0640h)**

REGISTER DESCRIPTION	REGISTER	OFFSET
USCI control 0	UCA2CTL0	00h
USCI control 1	UCA2CTL1	01h
USCI baud rate 0	UCA2BR0	06h
USCI baud rate 1	UCA2BR1	07h
USCI modulation control	UCA2MCTL	08h
USCI status	UCA2STAT	0Ah
USCI receive buffer	UCA2RXBUF	0Ch
USCI transmit buffer	UCA2TXBUF	0Eh
USCI LIN control	UCA2ABCTL	10h
USCI IrDA transmit control	UCA2IRTCTL	12h
USCI IrDA receive control	UCA2IRRCTL	13h
USCI interrupt enable	UCA2IE	1Ch
USCI interrupt flags	UCA2IFG	1Dh
USCI interrupt vector word	UCA2IV	1Eh

**Table 6-48. USCI\_B2 Registers (Base Address: 0660h)**

REGISTER DESCRIPTION	REGISTER	OFFSET
USCI synchronous control 0	UCB2CTL0	00h
USCI synchronous control 1	UCB2CTL1	01h
USCI synchronous bit rate 0	UCB2BR0	06h
USCI synchronous bit rate 1	UCB2BR1	07h
USCI synchronous status	UCB2STAT	0Ah
USCI synchronous receive buffer	UCB2RXBUF	0Ch
USCI synchronous transmit buffer	UCB2TXBUF	0Eh
USCI I2C own address	UCB2I2COA	10h
USCI I2C slave address	UCB2I2CSA	12h
USCI interrupt enable	UCB2IE	1Ch
USCI interrupt flags	UCB2IFG	1Dh
USCI interrupt vector word	UCB2IV	1Eh

**Table 6-49. ADC12\_A Registers (Base Address: 0700h)**

REGISTER DESCRIPTION	REGISTER	OFFSET
ADC12 control 0	ADC12CTL0	00h
ADC12 control 1	ADC12CTL1	02h
ADC12 control 2	ADC12CTL2	04h
Interrupt flag	ADC12IFG	0Ah
Interrupt enable	ADC12IE	0Ch
Interrupt vector word	ADC12IV	0Eh
ADC memory control 0	ADC12MCTL0	10h
ADC memory control 1	ADC12MCTL1	11h
ADC memory control 2	ADC12MCTL2	12h
ADC memory control 3	ADC12MCTL3	13h
ADC memory control 4	ADC12MCTL4	14h
ADC memory control 5	ADC12MCTL5	15h
ADC memory control 6	ADC12MCTL6	16h
ADC memory control 7	ADC12MCTL7	17h
ADC memory control 8	ADC12MCTL8	18h
ADC memory control 9	ADC12MCTL9	19h
ADC memory control 10	ADC12MCTL10	1Ah
ADC memory control 11	ADC12MCTL11	1Bh
ADC memory control 12	ADC12MCTL12	1Ch
ADC memory control 13	ADC12MCTL13	1Dh
ADC memory control 14	ADC12MCTL14	1Eh
ADC memory control 15	ADC12MCTL15	1Fh
Conversion memory 0	ADC12MEM0	20h
Conversion memory 1	ADC12MEM1	22h
Conversion memory 2	ADC12MEM2	24h
Conversion memory 3	ADC12MEM3	26h
Conversion memory 4	ADC12MEM4	28h
Conversion memory 5	ADC12MEM5	2Ah
Conversion memory 6	ADC12MEM6	2Ch
Conversion memory 7	ADC12MEM7	2Eh
Conversion memory 8	ADC12MEM8	30h
Conversion memory 9	ADC12MEM9	32h

**Table 6-49. ADC12\_A Registers (Base Address: 0700h) (continued)**

REGISTER DESCRIPTION	REGISTER	OFFSET
Conversion memory 10	ADC12MEM10	34h
Conversion memory 11	ADC12MEM11	36h
Conversion memory 12	ADC12MEM12	38h
Conversion memory 13	ADC12MEM13	3Ah
Conversion memory 14	ADC12MEM14	3Ch
Conversion memory 15	ADC12MEM15	3Eh

**Table 6-50. DAC12\_A Registers (Base Address: 0780h)**

REGISTER DESCRIPTION	REGISTER	OFFSET
DAC12_A channel 0 control 0	DAC12_0CTL0	00h
DAC12_A channel 0 control 1	DAC12_0CTL1	02h
DAC12_A channel 0 data	DAC12_0DAT	04h
DAC12_A channel 0 calibration control	DAC12_0CALCTL	06h
DAC12_A channel 0 calibration data	DAC12_0CALDAT	08h
DAC12_A channel 1 control 0	DAC12_1CTL0	10h
DAC12_A channel 1 control 1	DAC12_1CTL1	12h
DAC12_A channel 1 data	DAC12_1DAT	14h
DAC12_A channel 1 calibration control	DAC12_1CALCTL	16h
DAC12_A channel 1 calibration data	DAC12_1CALDAT	18h
DAC12_A interrupt vector word	DAC12IV	1Eh

**Table 6-51. Comparator\_B Registers (Base Address: 08C0h)**

REGISTER DESCRIPTION	REGISTER	OFFSET
Comp_B control 0	CBCTL0	00h
Comp_B control 1	CBCTL1	02h
Comp_B control 2	CBCTL2	04h
Comp_B control 3	CBCTL3	06h
Comp_B interrupt	CBINT	0Ch
Comp_B interrupt vector word	CBIV	0Eh

**Table 6-52. USB Configuration Registers (Base Address: 0900h)**

REGISTER DESCRIPTION	REGISTER	OFFSET
USB key/ID	USBKEYID	00h
USB module configuration	USBCNF	02h
USB PHY control	USBPHYCTL	04h
USB power control	USBPWRCTL	08h
USB power voltage setting	USBPWRVSR	0Ah
USB PLL control	USBPLLCTL	10h
USB PLL divider	USBPLLDIV	12h
USB PLL interrupts	USBPLLIR	14h

**Table 6-53. USB Control Registers (Base Address: 0920h)**

REGISTER DESCRIPTION	REGISTER	OFFSET
Input endpoint_0 configuration	USBIEPCNF_0	00h
Input endpoint_0 byte count	USBIEPCNT_0	01h
Output endpoint_0 configuration	USBOEPCNFG_0	02h
Output endpoint_0 byte count	USBOEPCNT_0	03h
Input endpoint interrupt enables	USBIEPIE	0Eh
Output endpoint interrupt enables	USBOEPIE	0Fh
Input endpoint interrupt flags	USBIEPIFG	10h
Output endpoint interrupt flags	USBOEPIFG	11h
USB interrupt vector	USBIV	12h
USB maintenance	USBMAINT	16h
Timestamp	USBTSREG	18h
USB frame number	USBFN	1Ah
USB control	USBCTL	1Ch
USB interrupt enables	USBIE	1Dh
USB interrupt flags	USBIFG	1Eh
Function address	USBFUNADR	1Fh

**Table 6-54. LDO and Port U Configuration Registers (Base Address: 0900h)**

REGISTER DESCRIPTION	REGISTER	OFFSET
LDO key/ID	LDOKEYID	00h
PU port control	PUCTL	04h
LDO power control	LDOPWRCTL	08h

**Table 6-55. LCD\_B Registers (Base Address: 0A00h)**

REGISTER DESCRIPTION	REGISTER	OFFSET
LCD_B control 0	LCDBCTL0	000h
LCD_B control 1	LCDBCTL1	002h
LCD_B blinking control	LCDBBLKCTL	004h
LCD_B memory control	LCDBMEMCTL	006h
LCD_B voltage control	LCDBVCTL	008h
LCD_B port control 0	LCDBPCTL0	00Ah
LCD_B port control 1	LCDBPCTL1	00Ch
LCD_B port control 2	LCDBPCTL2	00Eh
LCD_B charge pump control	LCDBCTL0	012h
LCD_B interrupt vector word	LCDBIV	01Eh
LCD_B memory 1	LCDM1	020h
LCD_B memory 2	LCDM2	021h
⋮	⋮	⋮
LCD_B memory 22	LCDM22	035h
LCD_B blinking memory 1	LCDBM1	040h
LCD_B blinking memory 2	LCDBM2	041h
⋮	⋮	⋮
LCD_B blinking memory 22	LCDBM22	055h

## 6.13 Input/Output Diagrams

### 6.13.1 Port P1 (P1.0 to P1.7) Input/Output With Schmitt Trigger

Figure 6-2 shows the port diagram. Table 6-56 summarizes selection of the pin functions.

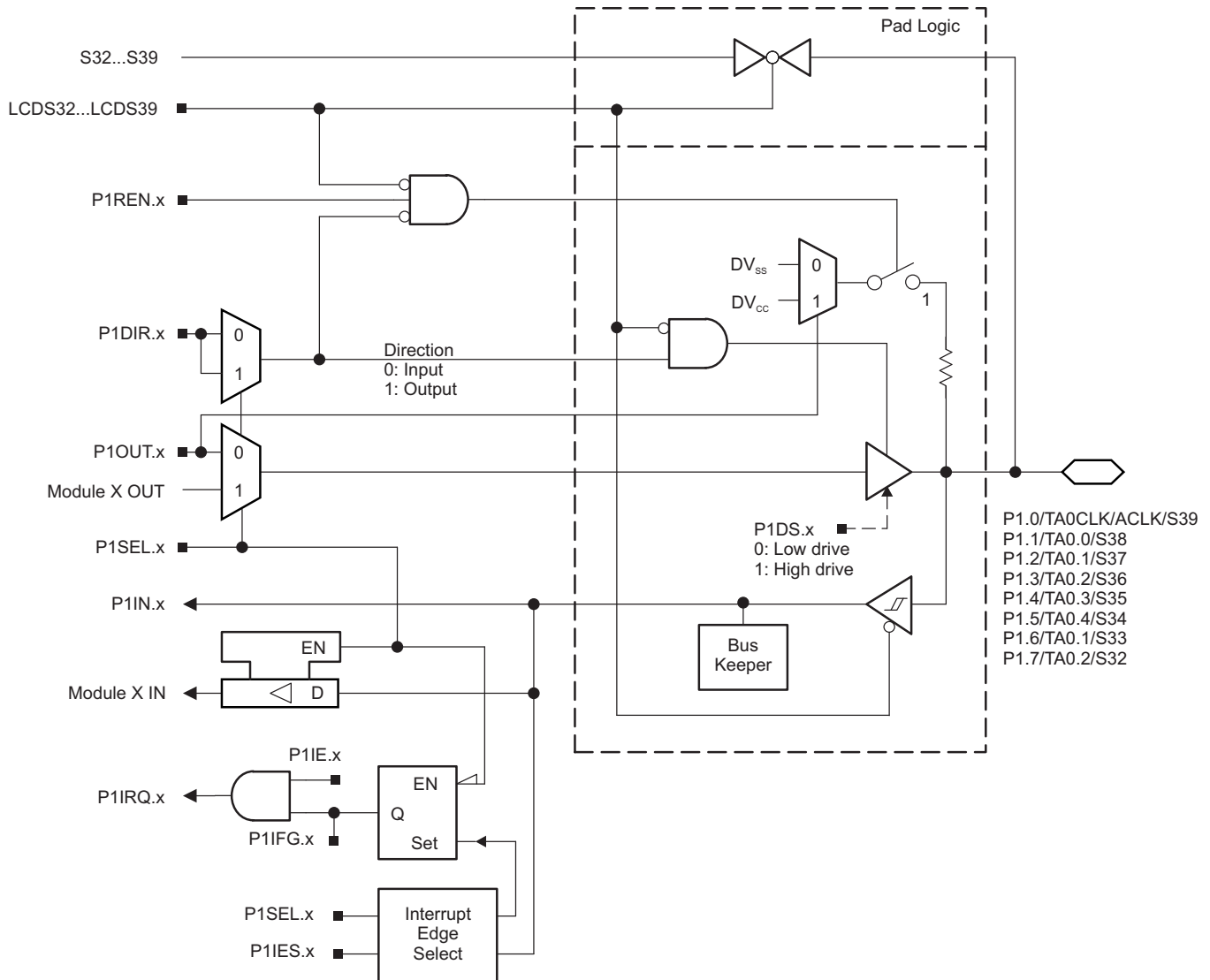

Figure 6-2. Port P1 (P1.0 to P1.7) Diagram

**Table 6-56. Port P1 (P1.0 to P1.7) Pin Functions**

PIN NAME (P1.x)	x	FUNCTION	CONTROL BITS OR SIGNALS <sup>(1)</sup>		
			P1DIR.x	P1SEL.x	LCDS32... LCDS39
P1.0/TA0CLK/ACLK/ S39	0	P1.0 (I/O)	I: 0; O: 1	0	0
		Timer TA0.TA0CLK	0	1	0
		ACLK	1	1	0
		S39	X	X	1
P1.1/TA0.0/S38	1	P1.1 (I/O)	I: 0; O: 1	0	0
		Timer TA0.CCI0A capture input	0	1	0
		Timer TA0.0 output	1	1	0
		S38	X	X	1
P1.2/TA0.1/S37	2	P1.2 (I/O)	I: 0; O: 1	0	0
		Timer TA0.CCI1A capture input	0	1	0
		Timer TA0.1 output	1	1	0
		S37	X	X	1
P1.3/TA0.2/S36	3	P1.3 (I/O)	I: 0; O: 1	0	0
		Timer TA0.CCI2A capture input	0	1	0
		Timer TA0.2 output	1	1	0
		S36	X	X	1
P1.4/TA0.3/S35	4	P1.4 (I/O)	I: 0; O: 1	0	0
		Timer TA0.CCI3A capture input	0	1	0
		Timer TA0.3 output	1	1	0
		S35	X	X	1
P1.5/TA0.4/S34	5	P1.5 (I/O)	I: 0; O: 1	0	0
		Timer TA0.CCI4A capture input	0	1	0
		Timer TA0.4 output	1	1	0
		S34	X	X	1
P1.6/TA0.1/S33	6	P1.6 (I/O)	I: 0; O: 1	0	0
		Timer TA0.CCI1B capture input	0	1	0
		Timer TA0.1 output	1	1	0
		S33	X	X	1
P1.7/TA0.2/S32	7	P1.7 (I/O)	I: 0; O: 1	0	0
		Timer TA0.CCI2B capture input	0	1	0
		Timer TA0.2 output	1	1	0
		S32	X	X	1

(1) X = Don't care

### 6.13.2 Port P2 (P2.0 to P2.7) Input/Output With Schmitt Trigger

Figure 6-3 shows the port diagram. Table 6-57 summarizes selection of the pin functions.

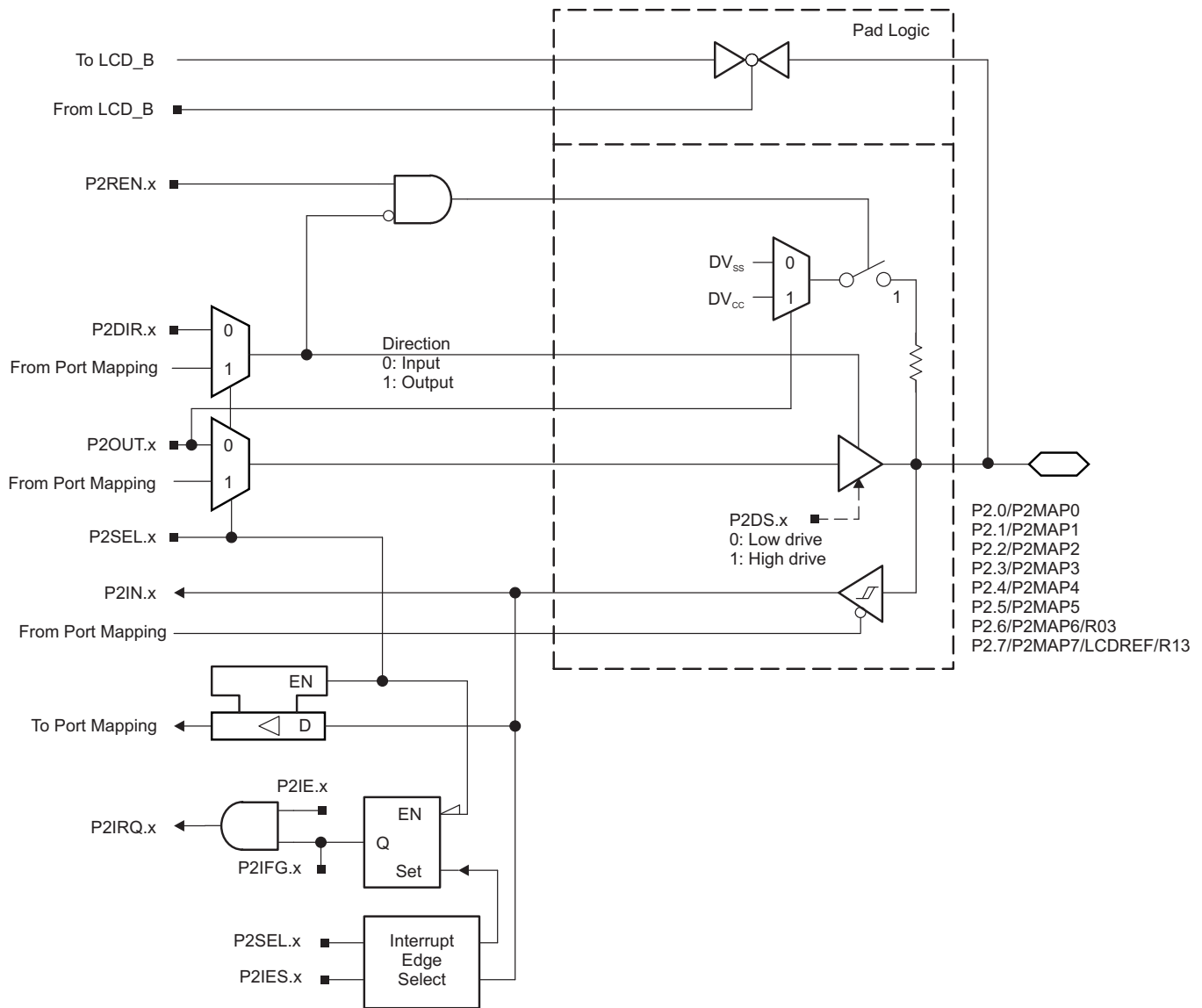

Figure 6-3. Port P2 (P2.0 to P2.7) Diagram

**Table 6-57. Port P2 (P2.0 to P2.7) Pin Functions**

PIN NAME (P2.x)	x	FUNCTION	CONTROL BITS OR SIGNALS <sup>(1)</sup>		
			P2DIR.x	P2SEL.x	P2MAPx
P2.0/P2MAP0	0	P2.0 (I/O)	I: 0; O: 1	0	
		Mapped secondary digital function	X	1	≤ 19
P2.1/P2MAP1	1	P2.1 (I/O)	I: 0; O: 1	0	
		Mapped secondary digital function	X	1	≤ 19
P2.2/P2MAP2	2	P2.2 (I/O)	I: 0; O: 1	0	
		Mapped secondary digital function	X	1	≤ 19
P2.3/P2MAP3	3	P2.3 (I/O)	I: 0; O: 1	0	
		Mapped secondary digital function	X	1	≤ 19
P2.4/P2MAP4	4	P2.4 (I/O)	I: 0; O: 1	0	
		Mapped secondary digital function	X	1	≤ 19
P2.5/P2MAP5	5	P2.5 (I/O)	I: 0; O: 1	0	
		Mapped secondary digital function	X	1	≤ 19
P2.6/P2MAP6/R03	6	P2.6 (I/O)	I: 0; O: 1	0	
		Mapped secondary digital function	X	1	≤ 19
		R03	X	1	= 31
P2.7/P2MAP7/ LCDREF/R13	7	P2.7 (I/O)	I: 0; O: 1	0	
		Mapped secondary digital function	X	1	≤ 19
		LCDREF/R13	X	1	= 31

(1) X = Don't care

### 6.13.3 Port P3 (P3.0 to P3.7) Input/Output With Schmitt Trigger

Figure 6-4 shows the port diagram. Table 6-58 summarizes selection of the pin functions.

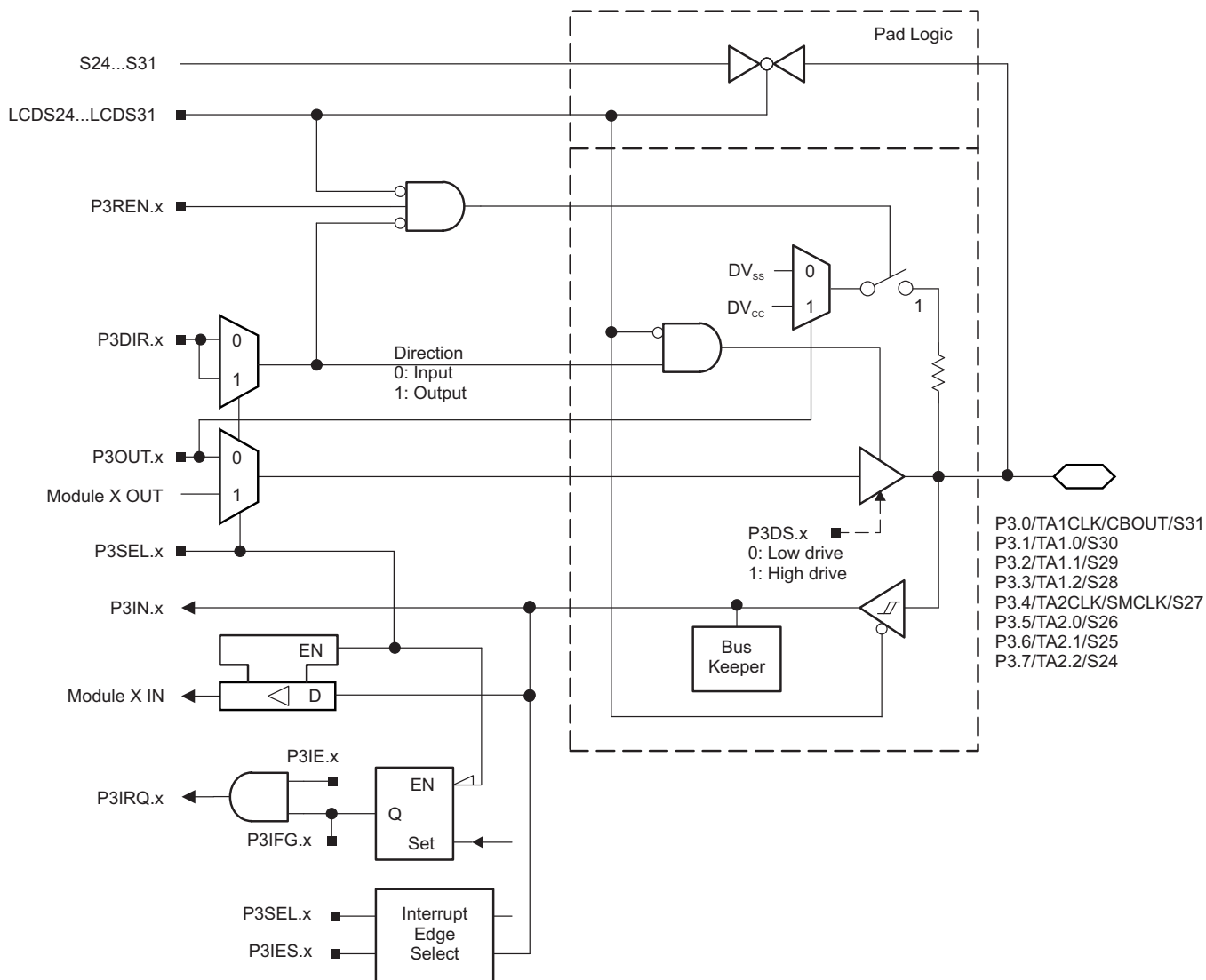

Figure 6-4. Port P3 (P3.0 to P3.7) Diagram

**Table 6-58. Port P3 (P3.0 to P3.7) Pin Functions**

PIN NAME (P3.x)	x	FUNCTION	CONTROL BITS OR SIGNALS <sup>(1)</sup>		
			P3DIR.x	P3SEL.x	LCDS24... LCDS31
P3.0/TA1CLK/CBOUT/ S31	0	P3.0 (I/O)	I: 0; O: 1	0	0
		Timer TA1.TA1CLK	0	1	0
		CBOUT	1	1	0
		S31	X	X	1
P3.1/TA1.0/S30	1	P3.1 (I/O)	I: 0; O: 1	0	0
		Timer TA1.CCI0A capture input	0	1	0
		Timer TA1.0 output	1	1	0
		S30	X	X	1
P3.2/TA1.1/S29	2	P3.2 (I/O)	I: 0; O: 1	0	0
		Timer TA1.CCI1A capture input	0	1	0
		Timer TA1.1 output	1	1	0
		S29	X	X	1
P3.3/TA1.2/S28	3	P3.3 (I/O)	I: 0; O: 1	0	0
		Timer TA1.CCI2A capture input	0	1	0
		Timer TA1.2 output	1	1	0
		S28	X	X	1
P3.4/TA2CLK/SMCLK/ S27	4	P3.4 (I/O)	I: 0; O: 1	0	0
		Timer TA2.TA2CLK	0	1	0
		SMCLK	1	1	0
		S27	X	X	1
P3.5/TA2.0/S26	5	P3.5 (I/O)	I: 0; O: 1	0	0
		Timer TA2.CCI0A capture input	0	1	0
		Timer TA2.0 output	1	1	0
		S26	X	X	1
P3.6/TA2.1/S25	6	P3.6 (I/O)	I: 0; O: 1	0	0
		Timer TA2.CCI1A capture input	0	1	0
		Timer TA2.1 output	1	1	1
		S25	X	X	1
P3.7/TA2.2/S24	7	P3.7 (I/O)	I: 0; O: 1	0	0
		Timer TA2.CCI2A capture input	0	1	0
		Timer TA2.2 output	1	1	0
		S24	X	X	1

(1) X = Don't care

### 6.13.4 Port P4 (P4.0 to P4.7) Input/Output With Schmitt Trigger

Figure 6-5 shows the port diagram. Table 6-59 summarizes selection of the pin functions.

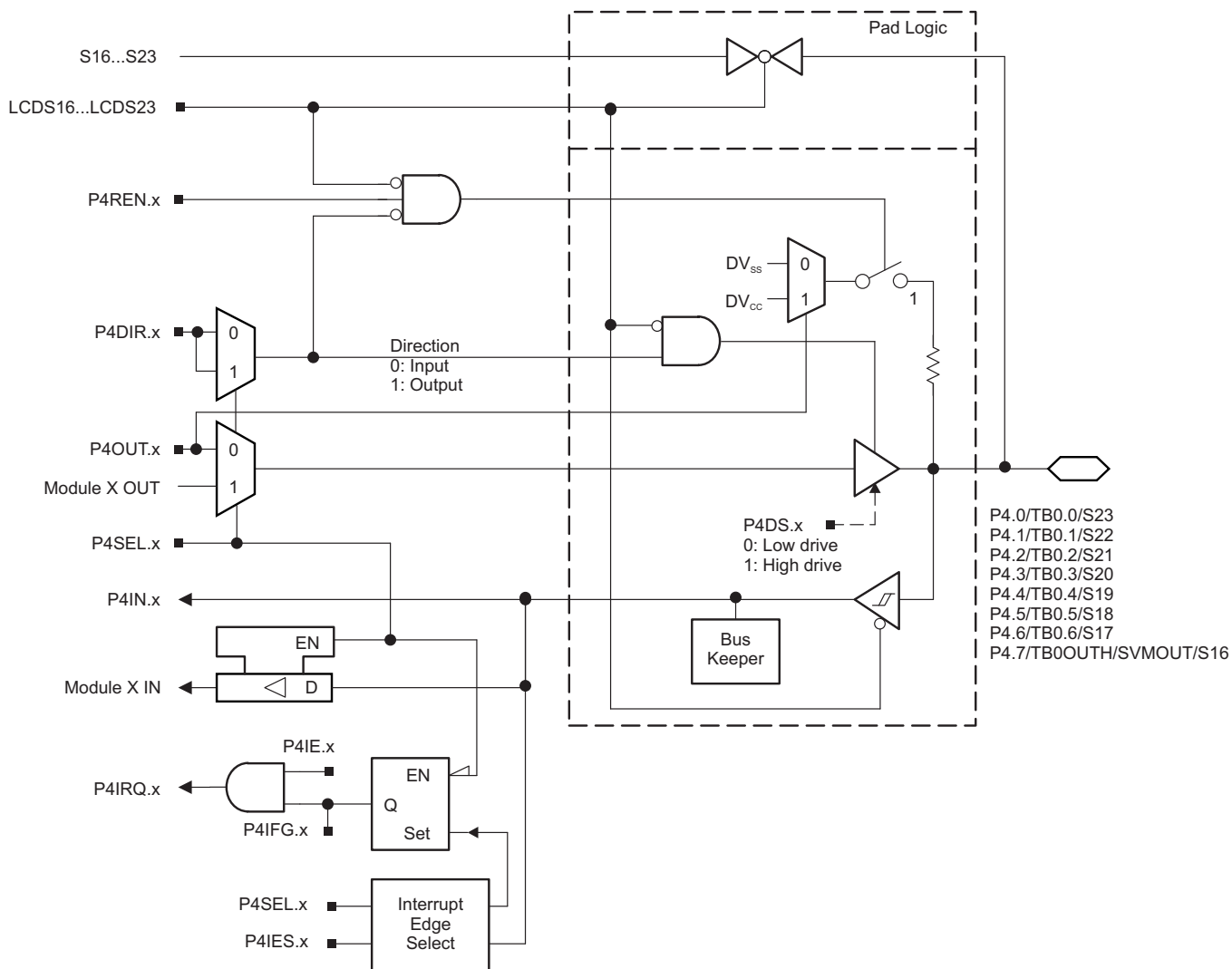

Figure 6-5. Port P4 (P4.0 to P4.7) Diagram

**Table 6-59. Port P4 (P4.0 to P4.7) Pin Functions**

PIN NAME (P4.x)	x	FUNCTION	CONTROL BITS OR SIGNALS <sup>(1)</sup>		
			P4DIR.x	P4SEL.x	LCDS16... LCDS23
P4.0/TB0.0/S23	0	P4.0 (I/O)	I: 0; O: 1	0	0
		Timer TB0.CCI0A capture input	0	1	0
		Timer TB0.0 output <sup>(2)</sup>	1	1	0
		S23	X	X	1
P4.1/TB0.1/S22	1	P4.1 (I/O)	I: 0; O: 1	0	0
		Timer TB0.CCI1A capture input	0	1	0
		Timer TB0.1 output <sup>(2)</sup>	1	1	0
		S22	X	X	1
P4.2/TB0.2/S21	2	P4.2 (I/O)	I: 0; O: 1	0	0
		Timer TB0.CCI2A capture input	0	1	0
		Timer TB0.2 output <sup>(2)</sup>	1	1	0
		S21	X	X	1
P4.3/TB0.3/S20	3	P4.3 (I/O)	I: 0; O: 1	0	0
		Timer TB0.CCI3A capture input	0	1	0
		Timer TB0.3 output <sup>(2)</sup>	1	1	0
		S20	X	X	1
P4.4/TB0.4/S19	4	P4.4 (I/O)	I: 0; O: 1	0	0
		Timer TB0.CCI4A capture input	0	1	0
		Timer TB0.4 output <sup>(2)</sup>	1	1	0
		S19	X	X	1
P4.5/TB0.5/S18	5	P4.5 (I/O)	I: 0; O: 1	0	0
		Timer TB0.CCI5A capture input	0	1	0
		Timer TB0.5 output <sup>(2)</sup>	1	1	0
		S18	X	X	1
P4.6/TB0.6/S17	6	P4.6 (I/O)	I: 0; O: 1	0	0
		Timer TB0.CCI6A capture input	0	1	0
		Timer TB0.6 output <sup>(2)</sup>	1	1	0
		S17	X	X	1
P4.7/TB0OUTH/ SVMOUT/S16	7	P4.7 (I/O)	I: 0; O: 1	0	0
		Timer TB0.TB0OUTH	0	1	0
		SVMOUT	1	1	0
		S16	X	X	1

(1) X = Don't care

(2) Setting TB0OUTH causes all Timer\_B configured outputs to be set to high impedance.

### 6.13.5 Port P5 (P5.0 and P5.1) Input/Output With Schmitt Trigger

Figure 6-6 shows the port diagram. Table 6-60 summarizes selection of the pin functions.

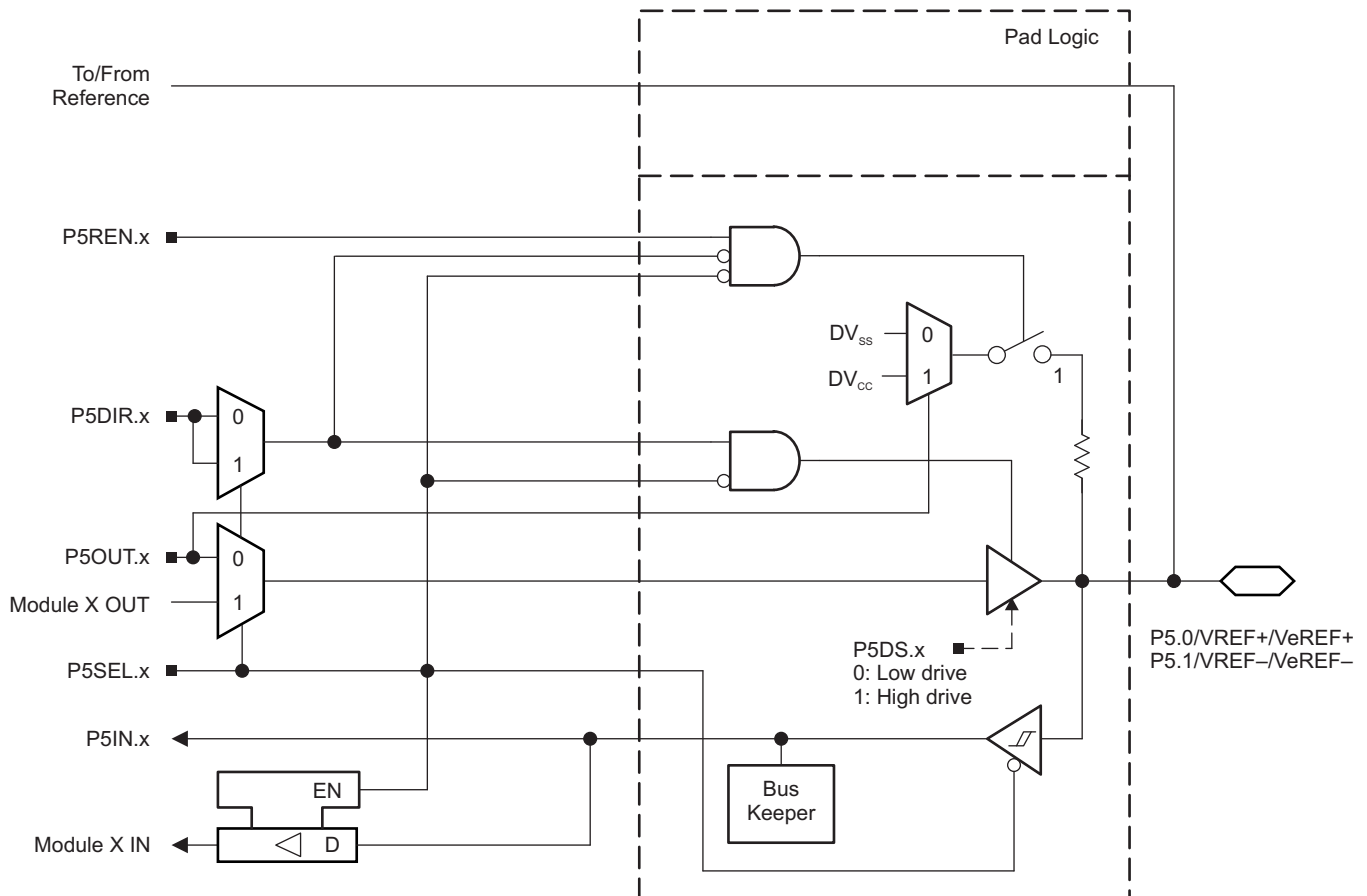

Figure 6-6. Port P5 (P5.0 and P5.1) Diagram

Table 6-60. Port P5 (P5.0 and P5.1) Pin Functions

PIN NAME (P5.x)	x	FUNCTION	CONTROL BITS OR SIGNALS <sup>(1)</sup>		
			P5DIR.x	P5SEL.x	REFOUT
P5.0/VREF+/VeREF+	0	P5.0 (I/O) <sup>(2)</sup>	I: 0; O: 1	0	X
		VeREF+ <sup>(3)</sup>	X	1	0
		VREF+ <sup>(4)</sup>	X	1	1
P5.1/VREF-/VeREF-	1	P5.1 (I/O) <sup>(2)</sup>	I: 0; O: 1	0	X
		VeREF- <sup>(5)</sup>	X	1	0
		VREF- <sup>(6)</sup>	X	1	1

- (1) X = Don't care
- (2) Default condition
- (3) Setting the P5SEL.0 bit disables the output driver and the input Schmitt trigger to prevent parasitic cross currents when applying analog signals. An external voltage can be applied to VeREF+ and used as the reference for the ADC12\_A, Comparator\_B, or DAC12\_A.
- (4) Setting the P5SEL.0 bit disables the output driver and the input Schmitt trigger to prevent parasitic cross currents when applying analog signals. The ADC12\_A, VREF+ reference is available at the pin.
- (5) Setting the P5SEL.1 bit disables the output driver and the input Schmitt trigger to prevent parasitic cross currents when applying analog signals. An external voltage can be applied to VeREF- and used as the reference for the ADC12\_A, Comparator\_B, or DAC12\_A.
- (6) Setting the P5SEL.1 bit disables the output driver and the input Schmitt trigger to prevent parasitic cross currents when applying analog signals. The ADC12\_A, VREF- reference is available at the pin.



**Table 6-61. Port P5 (P5.2 to P5.7) Pin Functions (continued)**

PIN NAME (P5.x)	x	FUNCTION	CONTROL BITS OR SIGNALS <sup>(1)</sup>		
			P5DIR.x	P5SEL.x	LCDS40... LCDS42
P5.7/RTCCLK	7	P5.7 (I/O)	I: 0; O: 1	0	N/A
		RTCCLK	1	1	N/A

### 6.13.7 Port P6 (P6.0 to P6.7) Input/Output With Schmitt Trigger

Figure 6-8 shows the port diagram. Table 6-62 summarizes selection of the pin functions.

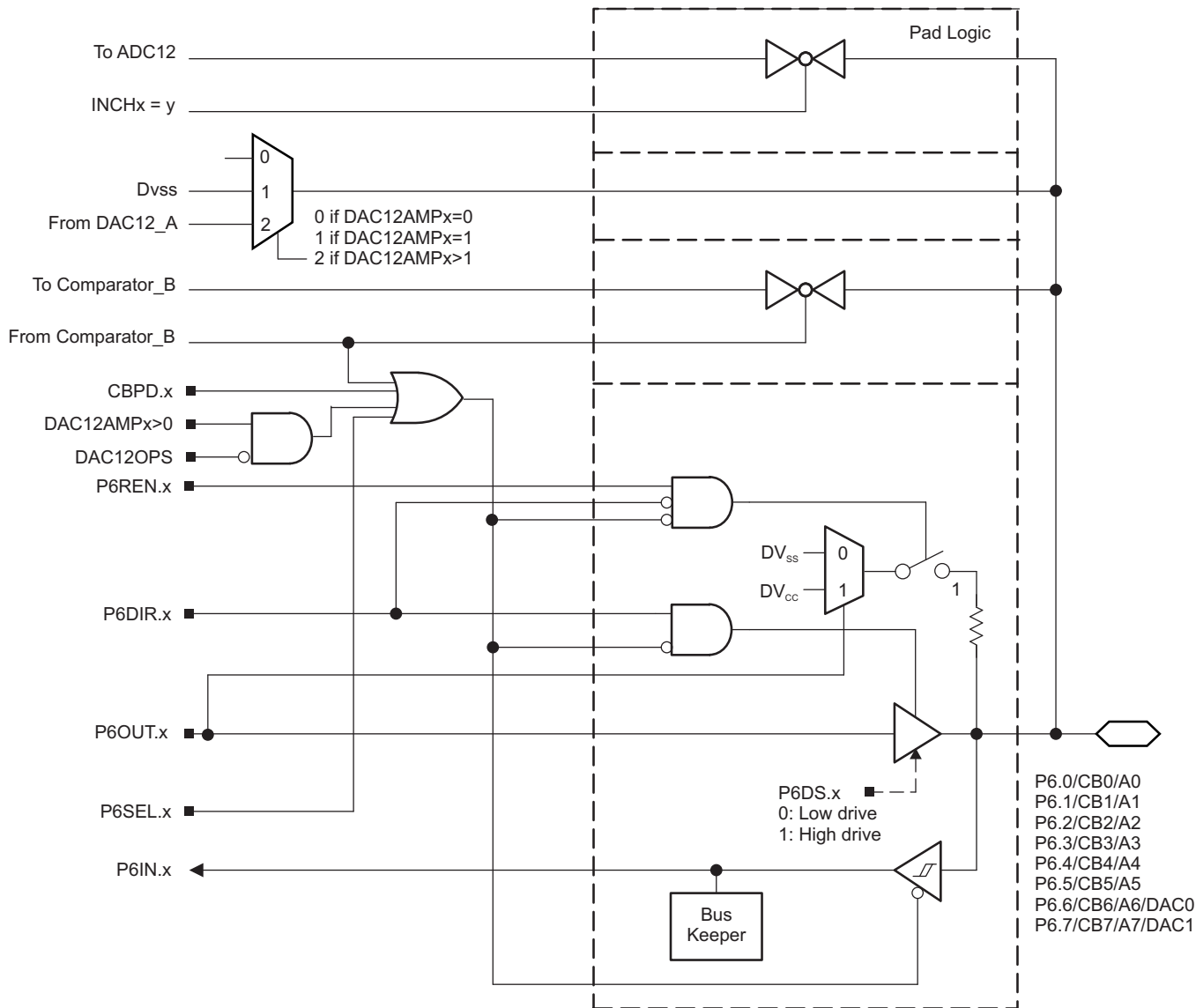

Figure 6-8. Port P6 (P6.0 to P6.7) Diagram

**Table 6-62. Port P6 (P6.0 to P6.7) Pin Functions**

PIN NAME (P6.x)	x	FUNCTION	CONTROL BITS OR SIGNALS <sup>(1)</sup>				
			P6DIR.x	P6SEL.x	CBPD.x	DAC12OPS	DAC12AMPx
P6.0/CB0/A0	0	P6.0 (I/O)	I: 0; O: 1	0	0	N/A	N/A
		CB0	X	X	1	N/A	N/A
		A0 <sup>(2)(3)</sup>	X	1	X	N/A	N/A
P6.1/CB1/A1	1	P6.1 (I/O)	I: 0; O: 1	0	0	N/A	N/A
		CB1	X	X	1	N/A	N/A
		A1 <sup>(2)(3)</sup>	X	1	X	N/A	N/A
P6.2/CB2/A2	2	P6.2 (I/O)	I: 0; O: 1	0	0	N/A	N/A
		CB2	X	X	1	N/A	N/A
		A2 <sup>(2)(3)</sup>	X	1	X	N/A	N/A
P6.3/CB3/A3	3	P6.3 (I/O)	I: 0; O: 1	0	0	N/A	N/A
		CB3	X	X	1	N/A	N/A
		A3 <sup>(2)(3)</sup>	X	1	X	N/A	N/A
P6.4/CB4/A4	4	P6.4 (I/O)	I: 0; O: 1	0	0	N/A	N/A
		CB4	X	X	1	N/A	N/A
		A4 <sup>(2)(3)</sup>	X	1	X	N/A	N/A
P6.5/CB5/A5	5	P6.5 (I/O)	I: 0; O: 1	0	0	N/A	N/A
		CB5	X	X	1	N/A	N/A
		A5 <sup>(2)(3)</sup>	X	1	X	N/A	N/A
P6.6/CB6/A6/DAC0	6	P6.6 (I/O)	I: 0; O: 1	0	0	X	0
		CB6	X	X	1	X	0
		A6 <sup>(2)(3)</sup>	X	1	X	X	0
		DAC0	X	X	X	0	>1
P6.7/CB7/A7/DAC1	7	P6.7 (I/O)	I: 0; O: 1	0	0	X	0
		CB7	X	X	1	X	0
		A7 <sup>(2)(3)</sup>	X	1	X	X	0
		DAC1	X	X	X	0	>1

- (1) X = Don't care
- (2) Setting the P6SEL.x bit disables the output driver and the input Schmitt trigger to prevent parasitic cross currents when applying analog signals.
- (3) The ADC12\_A channel Ax is connected internally to AV<sub>SS</sub> if not selected by the respective INCHx bits.

### 6.13.8 Port P7 (P7.2) Input/Output With Schmitt Trigger

Figure 6-9 shows the port diagram. Table 6-63 summarizes selection of the pin functions.

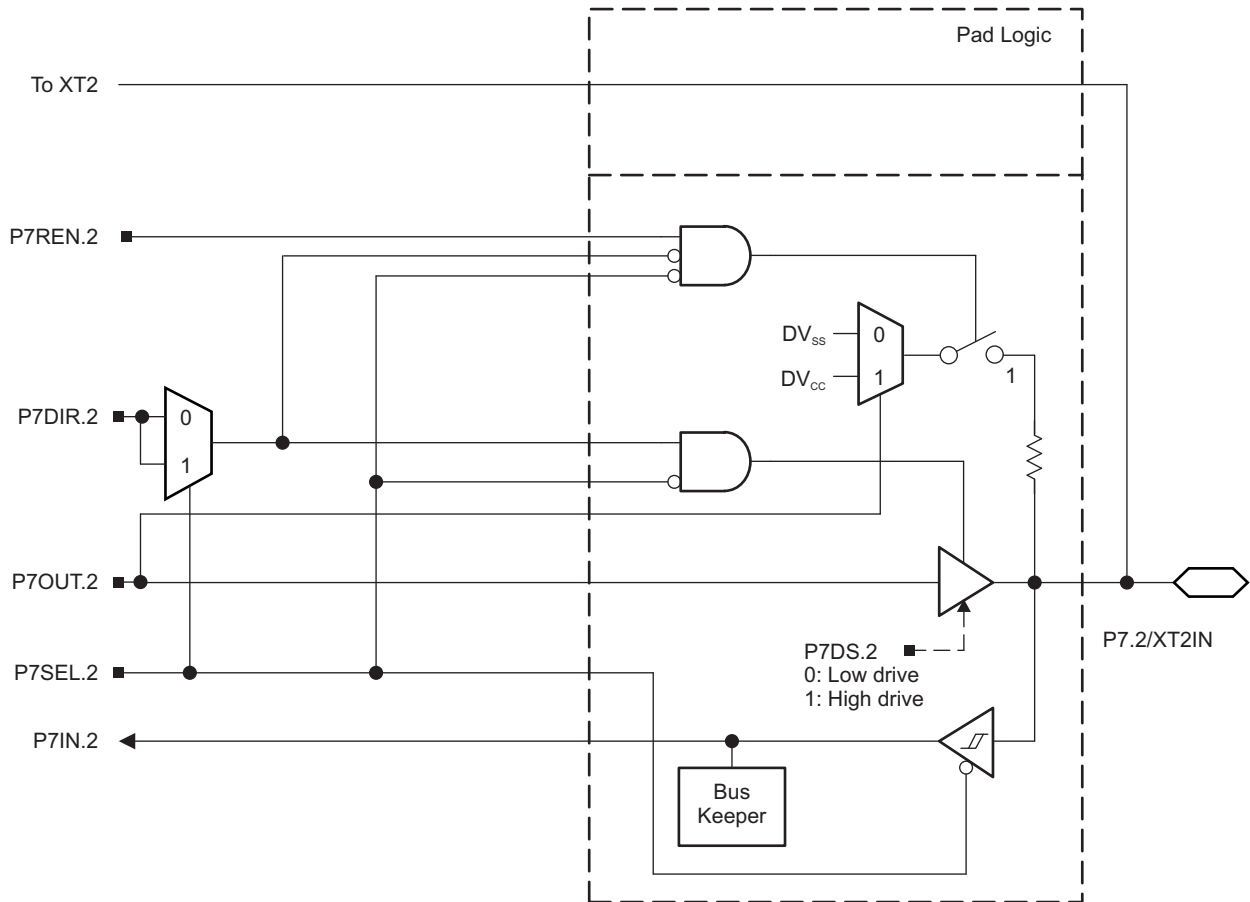

Figure 6-9. Port P7 (P7.2) Diagram

### 6.13.9 Port P7 (P7.3) Input/Output With Schmitt Trigger

Figure 6-10 shows the port diagram. Table 6-63 summarizes selection of the pin functions.

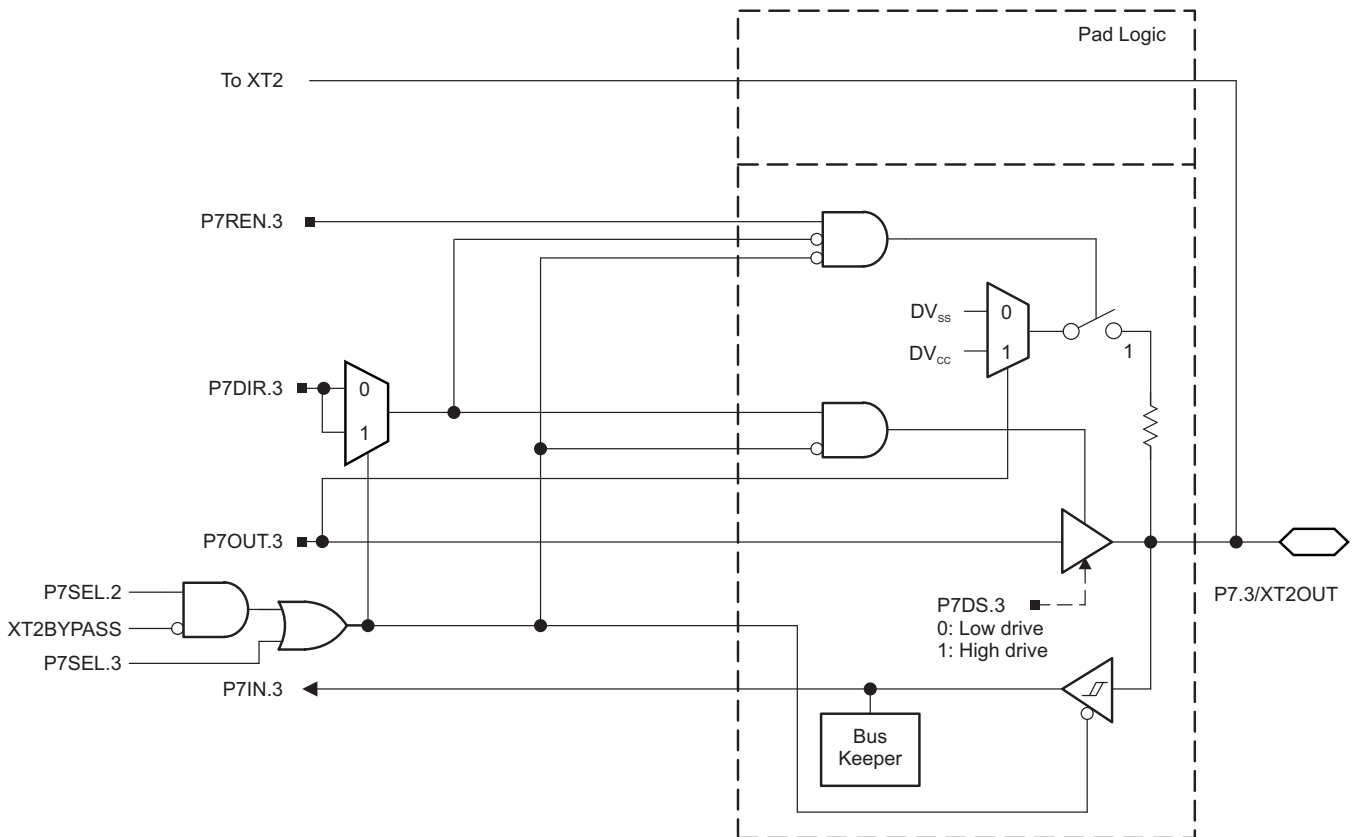

Figure 6-10. Port P7 (P7.3) Diagram

Table 6-63. Port P7 (P7.2 and P7.3) Pin Functions

PIN NAME (P7.x)	x	FUNCTION	CONTROL BITS OR SIGNALS <sup>(1)</sup>			
			P7DIR.x	P7SEL.2	P7SEL.3	XT2BYPASS
P7.2/XT2IN	2	P7.2 (I/O)	I: 0; O: 1	0	X	X
		XT2IN crystal mode <sup>(2)</sup>	X	1	X	0
		XT2IN bypass mode <sup>(2)</sup>	X	1	X	1
P7.3/XT2OUT	3	P7.3 (I/O)	I: 0; O: 1	0	0	X
		XT2OUT crystal mode <sup>(3)</sup>	X	1	X	0
		P7.3 (I/O) <sup>(3)</sup>	X	1	0	1

(1) X = Don't care

(2) Setting P7SEL.2 causes the general-purpose I/O to be disabled. Pending the setting of XT2BYPASS, P7.2 is configured for crystal mode or bypass mode.

(3) Setting P7SEL.2 causes the general-purpose I/O to be disabled in crystal mode. When using bypass mode, P7.3 can be used as general-purpose I/O.

### 6.13.10 Port P7 (P7.4 to P7.7) Input/Output With Schmitt Trigger

Figure 6-11 shows the port diagram. Table 6-64 summarizes selection of the pin functions.

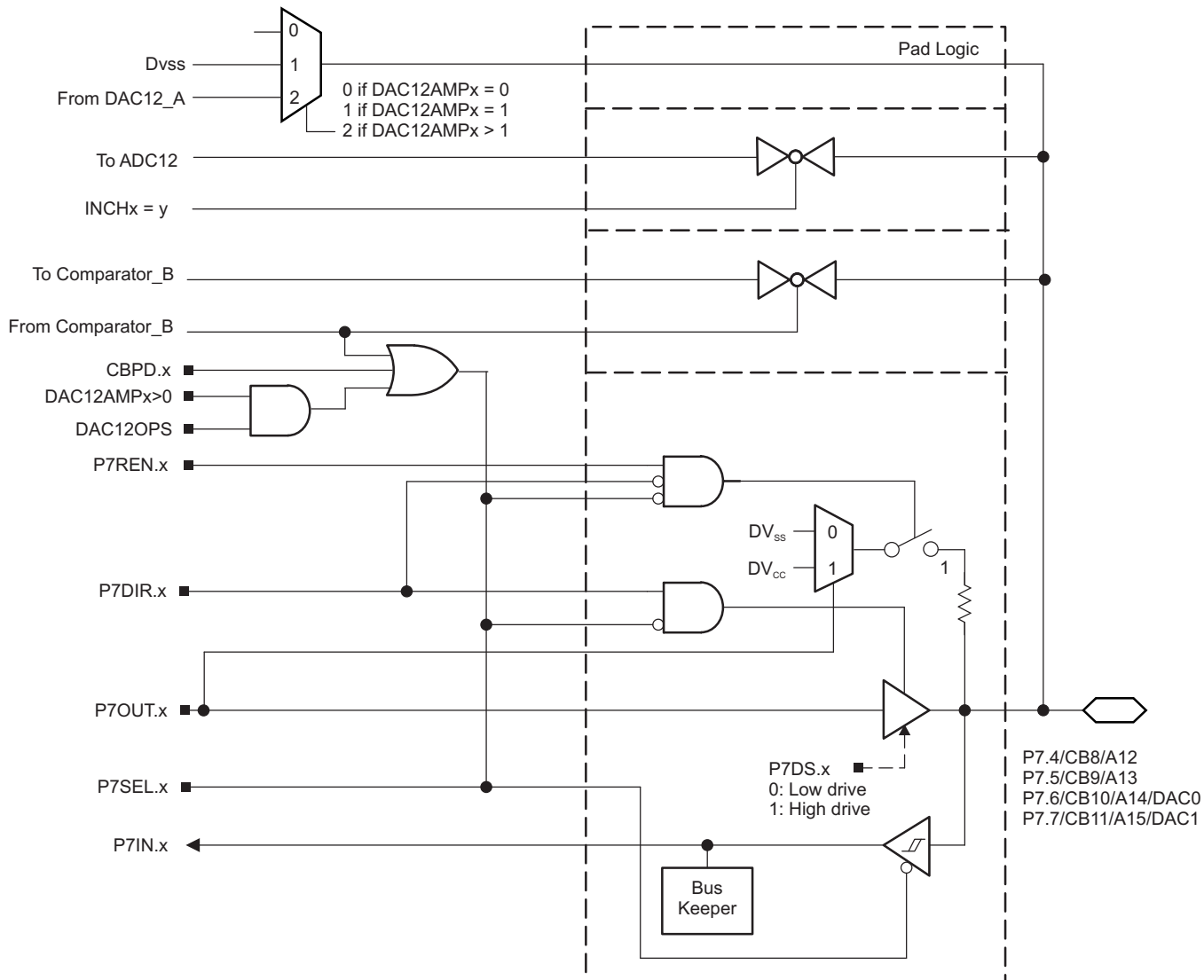

Figure 6-11. Port P7 (P7.4 to P7.7) Diagram

**Table 6-64. Port P7 (P7.4 to P7.7) Pin Functions**

PIN NAME (P7.x)	x	FUNCTION	CONTROL BITS OR SIGNALS <sup>(1)</sup>				
			P7DIR.x	P7SEL.x	CBPD.x	DAC12OPS	DAC12AMPx
P7.4/CB8/A12	4	P7.4 (I/O)	I: 0; O: 1	0	0	N/A	N/A
		Comparator_B input CB8	X	X	1	N/A	N/A
		A12 <sup>(2)(3)</sup>	X	1	X	N/A	N/A
P7.5/CB9/A13	5	P7.5 (I/O)	I: 0; O: 1	0	0	N/A	N/A
		Comparator_B input CB9	X	X	1	N/A	N/A
		A13 <sup>(2)(3)</sup>	X	1	X	N/A	N/A
P7.6/CB10/A14/DAC0	6	P7.6 (I/O)	I: 0; O: 1	0	0	X	0
		Comparator_B input CB10	X	X	1	X	0
		A14 <sup>(2)(3)</sup>	X	1	X	X	0
		DAC12_A output DAC0	X	X	X	1	>1
P7.7/CB11/A15/DAC1	7	P7.7 (I/O)	I: 0; O: 1	0	0	X	0
		A15 <sup>(2)(3)</sup>	X	1	X	X	0
		DAC12_A output DAC1	X	X	X	1	>1

(1) X = Don't care

(2) Setting the P7SEL.x bit disables the output driver and the input Schmitt trigger to prevent parasitic cross currents when applying analog signals.

(3) The ADC12\_A channel Ax is connected internally to AV<sub>SS</sub> if not selected by the respective INCHx bits.



**Table 6-65. Port P8 (P8.0 to P8.7) Pin Functions**

PIN NAME (P9.x)	x	FUNCTION	CONTROL BITS OR SIGNALS <sup>(1)</sup>		
			P8DIR.x	P8SEL.x	LCDS8... LCDS15
P8.0/TB0CLK/S15	0	P8.0 (I/O)	I: 0; O: 1	0	0
		Timer TB0.TB0CLK clock input	0	1	0
		S15	X	X	1
P8.1/UCB1STE/UCA1CLK/S14	1	P8.1 (I/O)	I: 0; O: 1	0	0
		UCB1STE/UCA1CLK	X	1	0
		S14	X	X	1
P8.2/UCA1TXD/UCA1SIMO/S13	2	P8.2 (I/O)	I: 0; O: 1	0	0
		UCA1TXD/UCA1SIMO	X	1	0
		S13	X	X	1
P8.3/UCA1RXD/UCA1SOMI/S12	3	P8.3 (I/O)	I: 0; O: 1	0	0
		UCA1RXD/UCA1SOMI	X	1	0
		S12	X	X	1
P8.4/UCB1CLK/UCA1STE/S11	4	P8.4 (I/O)	I: 0; O: 1	0	0
		UCB1CLK/UCA1STE	X	1	0
		S11	X	X	1
P8.5/UCB1SIMO/UCB1SDA/S10	5	P8.5 (I/O)	I: 0; O: 1	0	0
		UCB1SIMO/UCB1SDA	X	1	0
		S10	X	X	1
P8.6/UCB1SOMI/UCB1SCL/S9	6	P8.6 (I/O)	I: 0; O: 1	0	0
		UCB1SOMI/UCB1SCL	X	1	0
		S9	X	X	1
P8.7/S8	7	P8.7 (I/O)	I: 0; O: 1	0	0
		S8	X	X	1

(1) X = Don't care

### 6.13.12 Port P9 (P9.0 to P9.7) Input/Output With Schmitt Trigger

Figure 6-13 shows the port diagram. Table 6-66 summarizes selection of the pin functions.

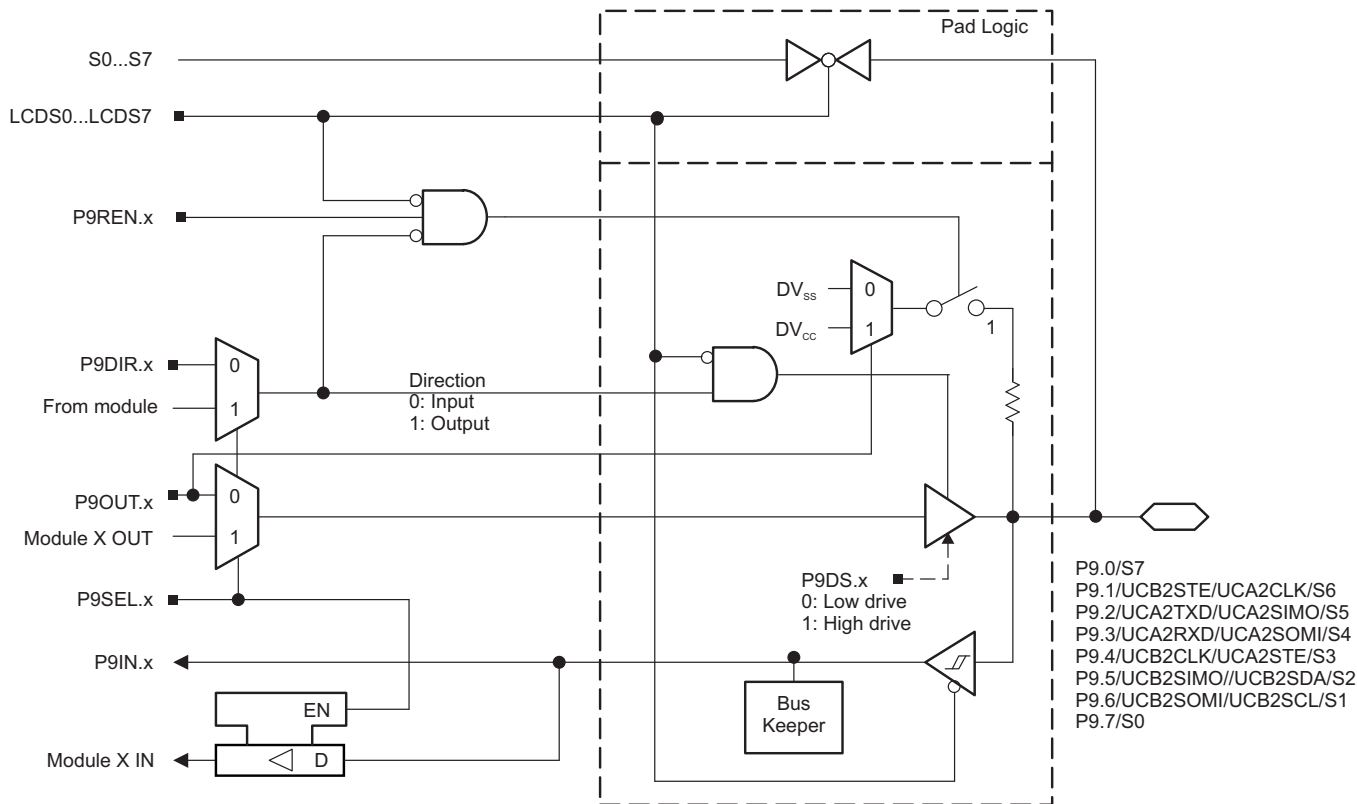

Figure 6-13. Port P9 (P9.0 to P9.7) Diagram

**Table 6-66. Port P9 (P9.0 to P9.7) Pin Functions**

PIN NAME (P9.x)	x	FUNCTION	CONTROL BITS OR SIGNALS <sup>(1)</sup>		
			P9DIR.x	P9SEL.x	LCDS0... LCDS7
P9.0/S7	0	P9.0 (I/O)	I: 0; O: 1	0	0
		S7	X	X	1
P9.1/UCB2STE/UCA2CLK/S6	1	P9.1 (I/O)	I: 0; O: 1	0	0
		UCB2STE/UCA2CLK	X	1	0
		S6	X	X	1
P9.2/UCA2TXD/UCA2SIMO/S5	2	P9.2 (I/O)	I: 0; O: 1	0	0
		UCA2TXD/UCA2SIMO	X	1	0
		S5	X	X	1
P9.3/UCA2RXD/UCA2SOMI/S4	3	P9.3 (I/O)	I: 0; O: 1	0	0
		UCA2RXD/UCA2SOMI	X	1	0
		S4	X	X	1
P9.4/UCB2CLK/UCA2STE/S3	4	P9.4 (I/O)	I: 0; O: 1	0	0
		UCB2CLK/UCA2STE	X	1	0
		S3	X	X	1
P9.5/UCB2SIMO/UCB2SDA/S2	5	P9.5 (I/O)	I: 0; O: 1	0	0
		UCB2SIMO/UCB2SDA	X	1	0
		S2	X	X	1
P9.6/UCB2SOMI/UCB2SCLK/S1	6	P9.6 (I/O)	I: 0; O: 1	0	0
		UCB2SOMI/UCB2SCLK	X	1	0
		S1	X	X	1
P9.7/S0	7	P9.7 (I/O)	I: 0; O: 1	0	0
		S0	X	X	1

(1) X = Don't care

6.13.13 Port PU (PU.0/DP, PU.1/DM, PUR) USB Ports (F665x, F565x)

Figure 6-14 shows the port diagram. Table 6-67 and Table 6-68 summarize selection of the pin functions.

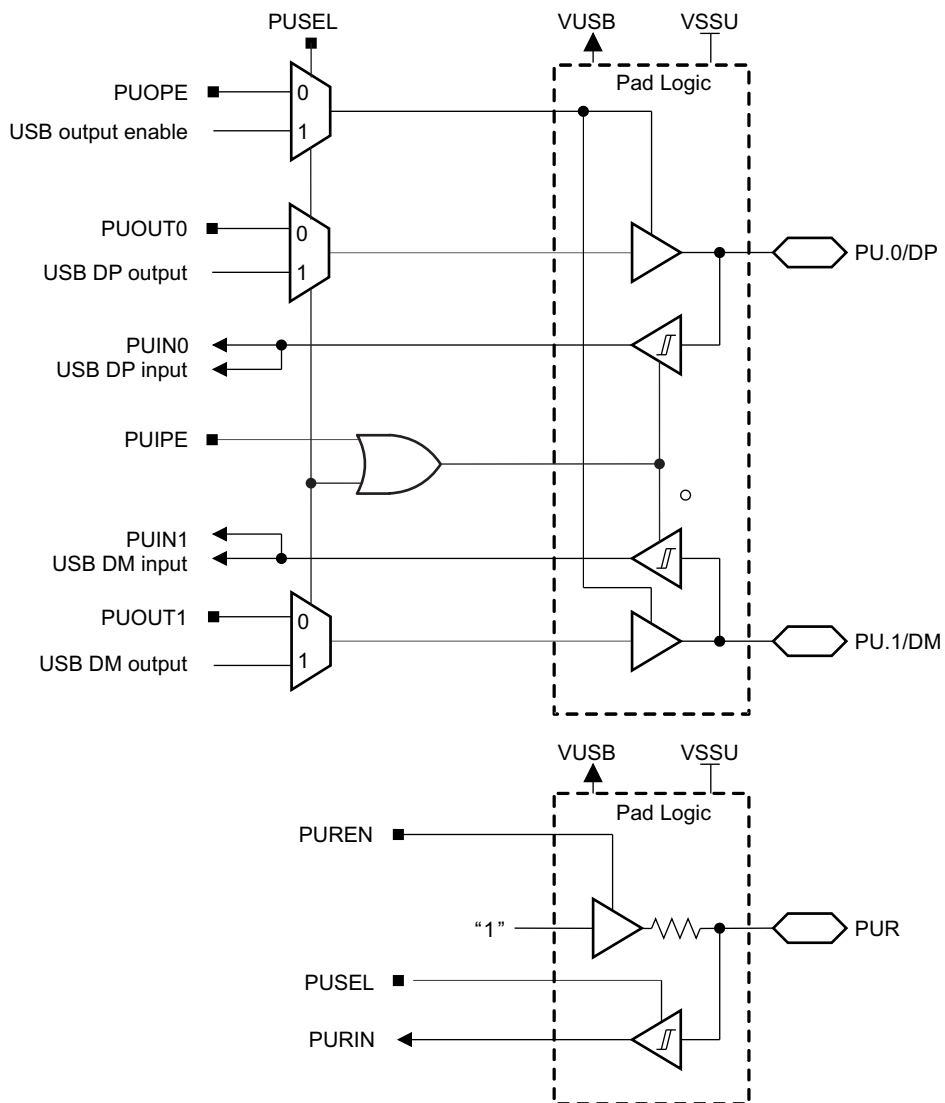

Figure 6-14. Port PU (PU.0 and PU.1) Diagram (F665x, F565x)

**Table 6-67. Port PU (PU.0, PU.1) Functions (F665x, F565x)**

PUSEL	PUIPE	PUOPE	PUOUT1	PUOUT0	PU.1/DM	PU.0/DP	PORT U FUNCTION
0	0	1	0	0	Output low	Output low	Outputs enabled
0	0	1	0	1	Output low	Output high	Outputs enabled
0	0	1	1	0	Output high	Output low	Outputs enabled
0	0	1	1	1	Output high	Output high	Outputs enabled
0	1	0	X	X	Input enabled	Input enabled	Inputs enabled
0	0	0	X	X	Hi-Z	Hi-Z	Outputs and inputs disabled
1	X	X	X	X	DM	DP	Direction set by USB module

**Table 6-68. Port PU (PUR) Input Functions (F665x, F565x)**

CONTROL BITS		FUNCTION
PUSEL	PUREN	
0	0	Input disabled Pullup disabled
0	1	Input disabled Pullup enabled
1	0	Input enabled Pullup disabled
1	1	Input enabled Pullup enabled

### 6.13.14 Port PU (PU.0 and PU.1) Ports (F645x, F535x)

Figure 6-15 shows the port diagram. Table 6-69 summarizes selection of the pin functions.

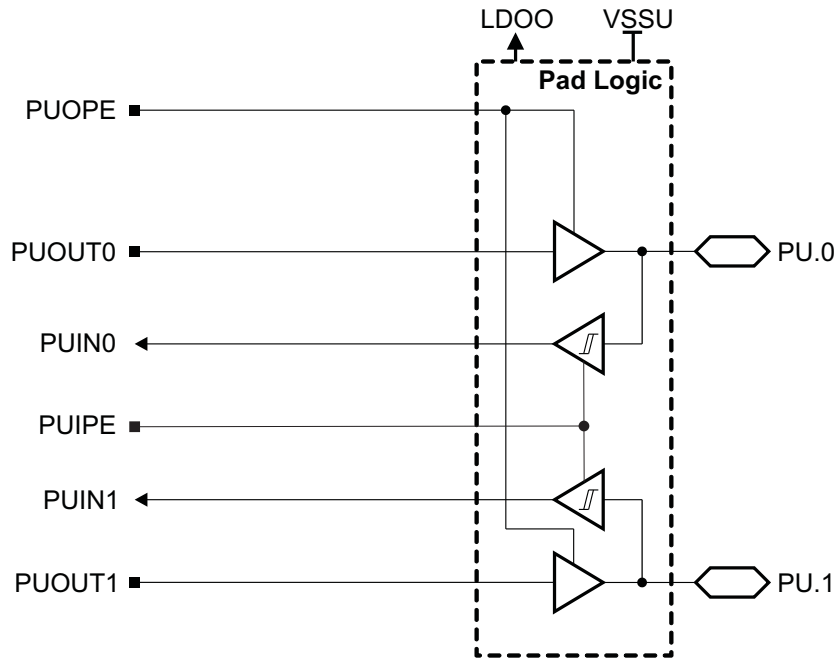

Figure 6-15. Port PU (PU.0 and PU.1) Diagram (F645x, F535x)

Table 6-69. Port PU (PU.0 and PU.1) Functions (F645x, F535x)<sup>(1)</sup>

PUIPE	PUOPE	PUOUT1	PUOUT0	PU.1	PU.0	PORT U FUNCTION
0	1	0	0	Output low	Output low	Outputs enabled
0	1	0	1	Output low	Output high	Outputs enabled
0	1	1	0	Output high	Output low	Outputs enabled
0	1	1	1	Output high	Output high	Outputs enabled
1	0	X	X	Input enabled	Input enabled	Inputs enabled
0	0	X	X	Hi-Z	Hi-Z	Outputs and inputs disabled

(1) PU.1 and PU.0 inputs and outputs are supplied from LDOO. LDOO can be generated by the device using the integrated 3.3-V LDO when enabled. LDOO can also be supplied externally when the 3.3-V LDO is not being used and is disabled.

### 6.13.15 Port PJ (PJ.0) JTAG Pin TDO, Input/Output With Schmitt Trigger or Output

Figure 6-16 shows the port diagram. Table 6-70 summarizes selection of the pin functions.

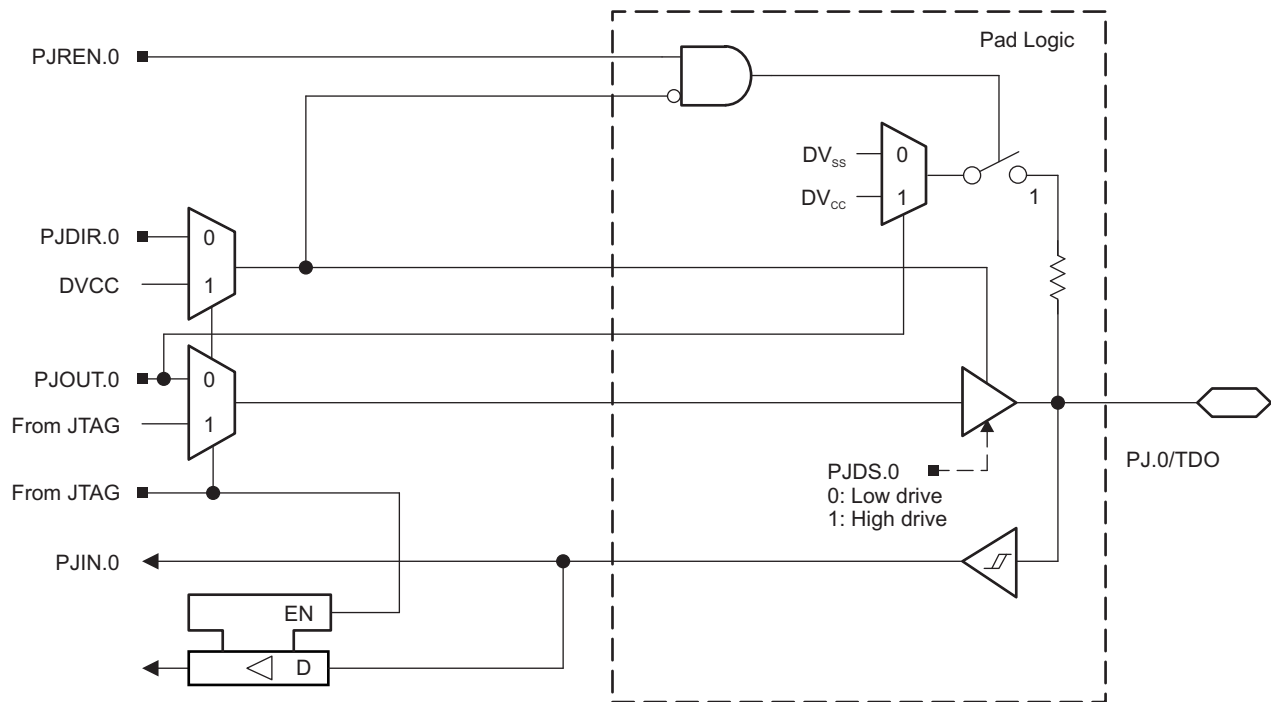

Figure 6-16. Port PJ (PJ.0) Diagram

### 6.13.16 Port PJ (PJ.1 to PJ.3) JTAG Pins TMS, TCK, TDI/TCLK, Input/Output With Schmitt Trigger or Output

Figure 6-17 shows the port diagram. Table 6-70 summarizes selection of the pin functions.

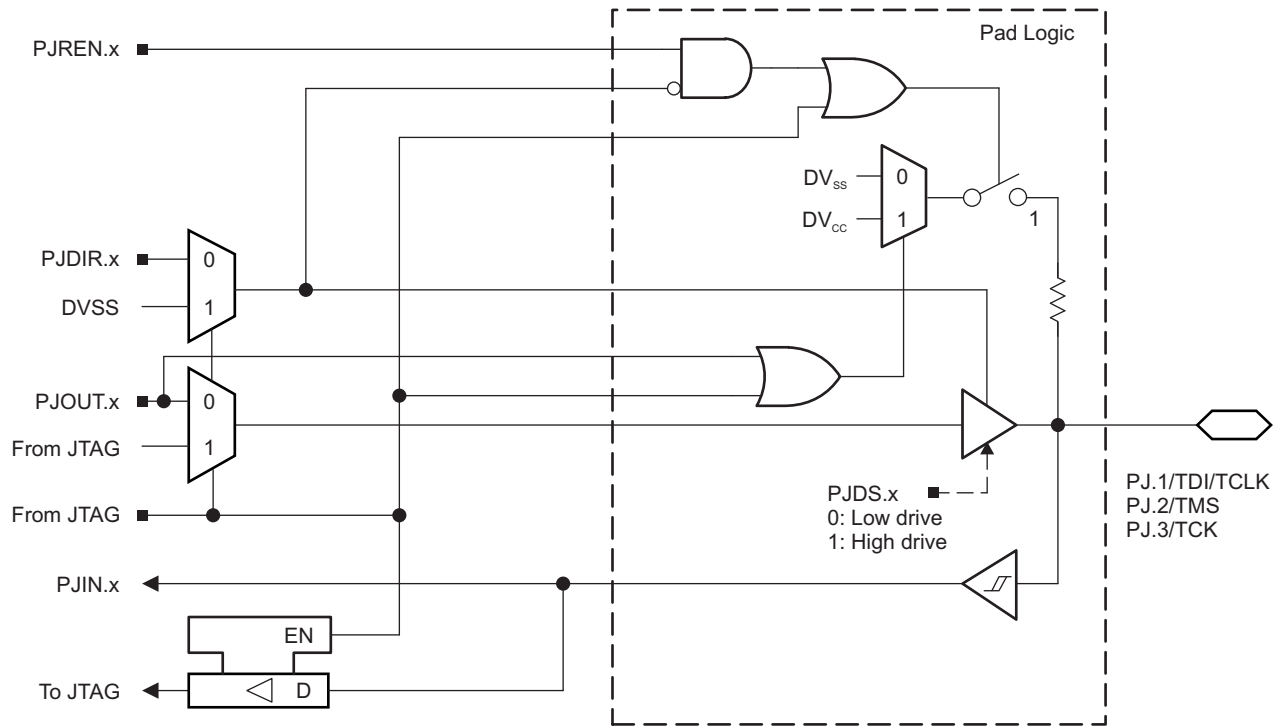

Figure 6-17. Port PJ (PJ.1 to PJ.3) Diagram

Table 6-70. Port PJ (PJ.0 to PJ.3) Pin Functions

PIN NAME (PJ.x)	x	FUNCTION	CONTROL BITS OR SIGNALS <sup>(1)</sup>
			PJDIR.x
PJ.0/TDO	0	PJ.0 (I/O) <sup>(2)</sup>	I: 0; O: 1
		TDO <sup>(3)</sup>	X
PJ.1/TDI/TCLK	1	PJ.1 (I/O) <sup>(2)</sup>	I: 0; O: 1
		TDI/TCLK <sup>(3) (4)</sup>	X
PJ.2/TMS	2	PJ.2 (I/O) <sup>(2)</sup>	I: 0; O: 1
		TMS <sup>(3) (4)</sup>	X
PJ.3/TCK	3	PJ.3 (I/O) <sup>(2)</sup>	I: 0; O: 1
		TCK <sup>(3) (4)</sup>	X

(1) X = Don't care

(2) Default condition

(3) The pin direction is controlled by the JTAG module.

(4) In JTAG mode, pullups are activated automatically on TMS, TCK, and TDI/TCLK. PJREN.x are do not care.

## 6.14 Device Descriptors

Table 6-71 lists the contents of the device descriptor tag-length-value (TLV) structure for each device type.

**Table 6-71. Device Descriptor Table<sup>(1)</sup>**

DESCRIPTION	ADDRESS	SIZE (bytes)	VALUE									
			F6659	F6658	F6459	F6458	F5659	F5658	F5359	F5358		
Info Block	Info length	01A00h	1	06h	06h	06h	06h	06h	06h	06h	06h	06h
	CRC length	01A01h	1	06h	06h	06h	06h	06h	06h	06h	06h	06h
	CRC value	01A02h	2	Per unit	Per unit	Per unit	Per unit	Per unit	Per unit	Per unit	Per unit	Per unit
	Device ID	01A04h	2	812Bh	812Ch	812Dh	812Eh	8130h	8131h	8132h	8133h	8133h
	Hardware revision	01A06h	1	10h	10h	10h	10h	10h	10h	10h	10h	10h
	Firmware revision	01A07h	1	10h	10h	10h	10h	10h	10h	10h	10h	10h
Die Record	Die record tag	01A08h	1	08h	08h	08h	08h	08h	08h	08h	08h	08h
	Die record length	01A09h	1	0Ah	0Ah	0Ah	0Ah	0Ah	0Ah	0Ah	0Ah	0Ah
	Lot/wafer ID	01A0Ah	4	Per unit	Per unit	Per unit	Per unit	Per unit	Per unit	Per unit	Per unit	Per unit
	Die X position	01A0Eh	2	Per unit	Per unit	Per unit	Per unit	Per unit	Per unit	Per unit	Per unit	Per unit
	Die Y position	01A10h	2	Per unit	Per unit	Per unit	Per unit	Per unit	Per unit	Per unit	Per unit	Per unit
	Test results	01A12h	2	Per unit	Per unit	Per unit	Per unit	Per unit	Per unit	Per unit	Per unit	Per unit
ADC12 Calibration	ADC12 calibration tag	01A14h	1	11h	11h	11h	11h	11h	11h	11h	11h	11h
	ADC12 calibration length	01A15h	1	10h	10h	10h	10h	10h	10h	10h	10h	10h
	ADC gain factor	01A16h	2	Per unit	Per unit	Per unit	Per unit	Per unit	Per unit	Per unit	Per unit	Per unit
	ADC offset	01A18h	2	Per unit	Per unit	Per unit	Per unit	Per unit	Per unit	Per unit	Per unit	Per unit
	ADC 1.5-V reference temperature sensor 30°C	01A1Ah	2	Per unit	Per unit	Per unit	Per unit	Per unit	Per unit	Per unit	Per unit	Per unit
	ADC 1.5-V reference temperature sensor 85°C	01A1Ch	2	Per unit	Per unit	Per unit	Per unit	Per unit	Per unit	Per unit	Per unit	Per unit
	ADC 2.0-V reference temperature sensor 30°C	01A1Eh	2	Per unit	Per unit	Per unit	Per unit	Per unit	Per unit	Per unit	Per unit	Per unit
	ADC 2.0-V reference temperature sensor 85°C	01A20h	2	Per unit	Per unit	Per unit	Per unit	Per unit	Per unit	Per unit	Per unit	Per unit
	ADC 2.5-V reference temperature sensor 30°C	01A22h	2	Per unit	Per unit	Per unit	Per unit	Per unit	Per unit	Per unit	Per unit	Per unit
	ADC 2.5-V reference temperature sensor 85°C	01A24h	2	Per unit	Per unit	Per unit	Per unit	Per unit	Per unit	Per unit	Per unit	Per unit
REF Calibration	REF calibration tag	01A26h	1	12h	12h	12h	12h	12h	12h	12h	12h	12h
	REF calibration length	01A27h	1	06h	06h	06h	06h	06h	06h	06h	06h	06h
	REF 1.5-V reference factor	01A28h	2	Per unit	Per unit	Per unit	Per unit	Per unit	Per unit	Per unit	Per unit	Per unit
	REF 2.0-V reference factor	01A2Ah	2	Per unit	Per unit	Per unit	Per unit	Per unit	Per unit	Per unit	Per unit	Per unit
	REF 2.5-V reference factor	01A2Ch	2	Per unit	Per unit	Per unit	Per unit	Per unit	Per unit	Per unit	Per unit	Per unit

(1) N/A = Not applicable

## 7 Device and Documentation Support

### 7.1 Getting Started and Next Steps

For more information on the MSP430™ family of devices and the tools and libraries that are available to help with your development, visit the [MSP430 ultra-low-power sensing and measurement MCUs overview](#).

### 7.2 Device Nomenclature

To designate the stages in the product development cycle, TI assigns prefixes to the part numbers of all MSP MCU devices. Each MSP MCU commercial family member has one of two prefixes: MSP or XMS. These prefixes represent evolutionary stages of product development from engineering prototypes (XMS) through fully qualified production devices (MSP).

**XMS** – Experimental device that is not necessarily representative of the final device's electrical specifications

**MSP** – Fully qualified production device

XMS devices are shipped against the following disclaimer:

"Developmental product is intended for internal evaluation purposes."

MSP devices have been characterized fully, and the quality and reliability of the device have been demonstrated fully. TI's standard warranty applies.

Predictions show that prototype devices (XMS) have a greater failure rate than the standard production devices. TI recommends that these devices not be used in any production system because their expected end-use failure rate still is undefined. Only qualified production devices are to be used.

TI device nomenclature also includes a suffix with the device family name. This suffix indicates the temperature range, package type, and distribution format. [Figure 7-1](#) provides a legend for reading the complete device name.

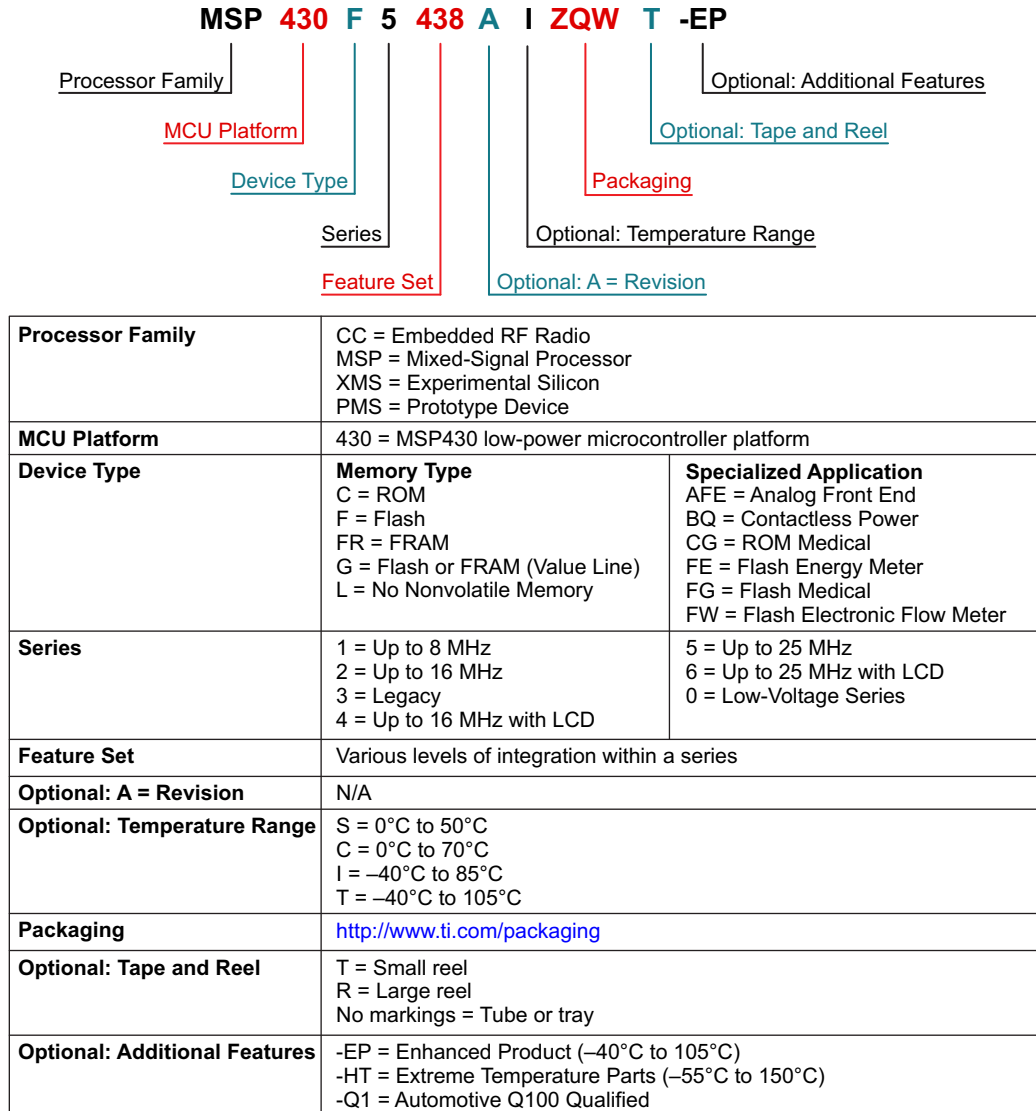

**Figure 7-1. Device Nomenclature**

## 7.3 Tools and Software

All MSP microcontrollers are supported by a wide variety of software and hardware development tools. Tools are available from TI and various third parties. See them all at [MSP430 Ultra-Low-Power MCUs – Tools & software](#).

Table 7-1 lists the debug features of the MSP430F665x, MSP430F645x, MSP430F565x, and MSP430F535x MCUs. See the [Code Composer Studio for MSP430 User's Guide](#) for details on the available features.

**Table 7-1. Hardware Debug Features**

MSP430 ARCHITECTURE	4-WIRE JTAG	2-WIRE JTAG	BREAK-POINTS (N)	RANGE BREAK-POINTS	CLOCK CONTROL	STATE SEQUENCER	TRACE BUFFER	LPMx.5 DEBUGGING SUPPORT
MSP430Xv2	Yes	Yes	8	Yes	Yes	Yes	Yes	Yes

### Design Kits and Evaluation Modules

#### **MSP-TS430PZ100USB - 100-pin Target Development Board for MSP430F5x and MSP430F6x MCUs**

The MSP-TS430PZ100USB is a stand-alone 100-pin ZIF socket target board used to program and debug the MSP430 MCU in-system through the JTAG interface or the Spy Bi-Wire (2-wire JTAG) protocol.

#### **100-pin Target Development Board and MSP-FET Programmer Bundle for MSP430F5x and MSP430F6x MCUs**

The MSP-TS430PZ100USB is a stand-alone 100-pin ZIF socket target board used to program and debug the MSP430 MCU in-system through the JTAG interface or the Spy Bi-Wire (2-wire JTAG) protocol. The MSP-FET is a powerful flash emulation tool to quickly begin application development on the MSP430 MCU. It includes USB debugging interface used to program and debug the MSP430 in-system through the JTAG interface or the pin saving Spy Bi-Wire (2-wire JTAG) protocol.

**MSP430F5529 USB LaunchPad Evaluation Kit** Develop low power, PC-connected applications with integrated Full-speed USB 2.0 (HID/MSC/CDC). The MSP-EXP430F5529LP LaunchPad is an inexpensive, simple microcontroller development kit for the MSP430F5529 USB microcontroller. It's an easy way to start developing on the MSP430 MCU, with an on-board emulation for programming and debugging, as well as buttons and LEDs for simple user interface.

### Software

**MSP430Ware™ Software** MSP430Ware software is a collection of code examples, data sheets, and other design resources for all MSP430 devices delivered in a convenient package. In addition to providing a complete collection of existing MSP430 MCU design resources, MSP430Ware software also includes a high-level API called MSP Driver Library. This library makes it easy to program MSP430 hardware. MSP430Ware software is available as a component of CCS or as a stand-alone package.

**MSP430F665x, MSP430F565x Code Examples** C code examples that configure each of the integrated peripherals for various application needs.

**MSP Driver Library** Driver Library's abstracted API keeps you above the bits and bytes of the MSP430 hardware by providing easy-to-use function calls. Thorough documentation is delivered through a helpful API Guide, which includes details on each function call and the recognized parameters. Developers can use Driver Library functions to write complete projects with minimal overhead.

**MSP EnergyTrace™ Technology** EnergyTrace technology for MSP430 microcontrollers is an energy-based code analysis tool that measures and displays the application's energy profile and helps to optimize it for ultra-low-power consumption.

**ULP (Ultra-Low Power) Advisor** ULP Advisor™ software is a tool for guiding developers to write more efficient code to fully utilize the unique ultra-low power features of MSP and MSP432 microcontrollers. Aimed at both experienced and new microcontroller developers, ULP Advisor checks your code against a thorough ULP checklist to squeeze every last nano amp out of your application. At build time, ULP Advisor will provide notifications and remarks to highlight areas of your code that can be further optimized for lower power.

**IEC60730 Software Package** The IEC60730 MSP430 software package was developed to be useful in assisting customers in complying with IEC 60730-1:2010 (Automatic Electrical Controls for Household and Similar Use – Part 1: General Requirements) for up to Class B products, which includes home appliances, arc detectors, power converters, power tools, e-bikes, and many others. The IEC60730 MSP430 software package can be embedded in customer applications running on MSP430s to help simplify the customer's certification efforts of functional safety-compliant consumer devices to IEC 60730-1:2010 Class B.

**Fixed Point Math Library for MSP** The MSP IQmath and Qmath Libraries are a collection of highly optimized and high-precision mathematical functions for C programmers to seamlessly port a floating-point algorithm into fixed-point code on MSP430 and MSP432 devices. These routines are typically used in computationally intensive real-time applications where optimal execution speed, high accuracy, and ultra-low energy are critical. By using the IQmath and Qmath libraries, it is possible to achieve execution speeds considerably faster and energy consumption considerably lower than equivalent code written using floating-point math.

**Floating Point Math Library for MSP430** Continuing to innovate in the low power and low cost microcontroller space, TI brings you MSPMATHLIB. Leveraging the intelligent peripherals of our devices, this floating point math library of scalar functions brings you up to 26x better performance. Mathlib is easy to integrate into your designs. This library is free and is integrated in both Code Composer Studio and IAR IDEs. Read the user's guide for an in depth look at the math library and relevant benchmarks.

## Development Tools

**Code Composer Studio™ Integrated Development Environment for MSP Microcontrollers** Code Composer Studio is an integrated development environment (IDE) that supports all MSP microcontroller devices. Code Composer Studio comprises a suite of embedded software utilities used to develop and debug embedded applications. It includes an optimizing C/C++ compiler, source code editor, project build environment, debugger, profiler, and many other features. The intuitive IDE provides a single user interface taking you through each step of the application development flow. Familiar utilities and interfaces allow users to get started faster than ever before. Code Composer Studio combines the advantages of the Eclipse software framework with advanced embedded debug capabilities from TI resulting in a compelling feature-rich development environment for embedded developers. When using CCS with an MSP MCU, a unique and powerful set of plugins and embedded software utilities are made available to fully leverage the MSP microcontroller.

**Command-Line Programmer** MSP Flasher is an open-source shell-based interface for programming MSP microcontrollers through a FET programmer or eZ430 using JTAG or Spy-Bi-Wire (SBW) communication. MSP Flasher can download binary files (.txt or .hex) files directly to the MSP microcontroller without an IDE.

**MSP MCU Programmer and Debugger** The MSP-FET is a powerful emulation development tool – often called a debug probe – which allows users to quickly begin application development on MSP low-power microcontrollers (MCU). Creating MCU software usually requires downloading the resulting binary program to the MSP device for validation and debugging. The MSP-FET provides a debug communication pathway between a host computer and the target MSP. Furthermore, the MSP-FET also provides a Backchannel UART connection between the computer's USB interface and the MSP UART. This affords the MSP programmer a convenient method for communicating serially between the MSP and a terminal running on the computer. It also supports loading programs (often called firmware) to the MSP target using the BSL (bootloader) through the UART and I<sup>2</sup>C communication protocols.

**MSP-GANG Production Programmer** The MSP Gang Programmer is an MSP430 or MSP432 device programmer that can program up to eight identical MSP430 or MSP432 Flash or FRAM devices at the same time. The MSP Gang Programmer connects to a host PC using a standard RS-232 or USB connection and provides flexible programming options that allow the user to fully customize the process. The MSP Gang Programmer is provided with an expansion board, called the Gang Splitter, that implements the interconnections between the MSP Gang Programmer and multiple target devices. Eight cables are provided that connect the expansion board to eight target devices (through JTAG or Spy-Bi-Wire connectors). The programming can be done with a PC or as a stand-alone device. A PC-side graphical user interface is also available and is DLL-based.

## 7.4 Documentation Support

The following documents describe the MSP430F665x, MSP430F645x, MSP430F565x, and MSP430F535x MCUs. Copies of these documents are available on the Internet at [www.ti.com](http://www.ti.com).

### Receiving Notification of Document Updates

To receive notification of documentation updates—including silicon errata—go to the product folder for your device on [ti.com](http://ti.com) (for links to the product folders, see [Section 7.5](#)). In the upper right corner, click the "Alert me" button. This registers you to receive a weekly digest of product information that has changed (if any). For change details, check the revision history of any revised document.

### Errata

**MSP430F6659 Device Erratasheet** Describes the known exceptions to the functional specifications for all silicon revisions of this device.

**MSP430F6658 Device Erratasheet** Describes the known exceptions to the functional specifications for all silicon revisions of this device.

**MSP430F6459 Device Erratasheet** Describes the known exceptions to the functional specifications for all silicon revisions of this device.

**MSP430F6458 Device Erratasheet** Describes the known exceptions to the functional specifications for all silicon revisions of this device.

**MSP430F5659 Device Erratasheet** Describes the known exceptions to the functional specifications for all silicon revisions of this device.

**MSP430F5658 Device Erratasheet** Describes the known exceptions to the functional specifications for all silicon revisions of this device.

**MSP430F5359 Device Erratasheet** Describes the known exceptions to the functional specifications for all silicon revisions of this device.

**MSP430F5358 Device Erratasheet** Describes the known exceptions to the functional specifications for all silicon revisions of this device.

### User's Guides

**MSP430F5xx and MSP430F6xx Family User's Guide** Detailed information on the modules and peripherals available in this device family.

**MSP430 Flash Device Bootloader (BSL) User's Guide** The MSP430 bootloader (BSL) lets users communicate with embedded memory in the MSP430 microcontroller during the prototyping phase, final production, and in service. Both the programmable memory (flash memory) and the data memory (RAM) can be modified as required. Do not confuse the bootloader with the bootstrap loader programs found in some digital signal processors (DSPs) that automatically load program code (and data) from external memory to the internal memory of the DSP.

**MSP430 Programming With the JTAG Interface** This document describes the functions that are required to erase, program, and verify the memory module of the MSP430 flash-based and FRAM-based microcontroller families using the JTAG communication port. In addition, it describes how to program the JTAG access security fuse that is available on all MSP430 devices. This document describes device access using both the standard 4-wire JTAG interface and the 2-wire JTAG interface, which is also referred to as Spy-Bi-Wire (SBW).

**MSP430 Hardware Tools User's Guide** This manual describes the hardware of the TI MSP-FET430 Flash Emulation Tool (FET). The FET is the program development tool for the MSP430 ultra-low-power microcontroller. Both available interface types, the parallel port interface and the USB interface, are described.

### Application Reports

**MSP430 32-kHz Crystal Oscillators** Selection of the right crystal, correct load circuit, and proper board layout are important for a stable crystal oscillator. This application report summarizes crystal oscillator function and explains the parameters to select the correct crystal for MSP430 ultra-low-power operation. In addition, hints and examples for correct board layout are given. The document also contains detailed information on the possible oscillator tests to ensure stable oscillator operation in mass production.

**MSP430 System-Level ESD Considerations** System-Level ESD has become increasingly demanding as silicon technology scales to lower voltages and the need for designing cost-effective and ultra-low-power components. This application report addresses three ESD topics to help board designers and OEMs understand and design robust system-level designs: (1) Component-level ESD testing and system-level ESD testing; (2) General design guidelines for system-level ESD protection; (3) Introduction to System Efficient ESD Design (SEED), a co-design methodology of on-board and on-chip ESD protection. A few real-world system-level ESD protection design examples and their results are discussed.

## 7.5 Related Links

Table 7-2 lists quick access links. Categories include technical documents, support and community resources, tools and software, and quick access to sample or buy.

**Table 7-2. Related Links**

PARTS	PRODUCT FOLDER	ORDER NOW	TECHNICAL DOCUMENTS	TOOLS & SOFTWARE	SUPPORT & COMMUNITY
MSP430F6659	<a href="#">Click here</a>	<a href="#">Click here</a>	<a href="#">Click here</a>	<a href="#">Click here</a>	<a href="#">Click here</a>
MSP430F6658	<a href="#">Click here</a>	<a href="#">Click here</a>	<a href="#">Click here</a>	<a href="#">Click here</a>	<a href="#">Click here</a>
MSP430F6459	<a href="#">Click here</a>	<a href="#">Click here</a>	<a href="#">Click here</a>	<a href="#">Click here</a>	<a href="#">Click here</a>
MSP430F6458	<a href="#">Click here</a>	<a href="#">Click here</a>	<a href="#">Click here</a>	<a href="#">Click here</a>	<a href="#">Click here</a>
MSP430F5659	<a href="#">Click here</a>	<a href="#">Click here</a>	<a href="#">Click here</a>	<a href="#">Click here</a>	<a href="#">Click here</a>
MSP430F5658	<a href="#">Click here</a>	<a href="#">Click here</a>	<a href="#">Click here</a>	<a href="#">Click here</a>	<a href="#">Click here</a>
MSP430F5359	<a href="#">Click here</a>	<a href="#">Click here</a>	<a href="#">Click here</a>	<a href="#">Click here</a>	<a href="#">Click here</a>
MSP430F5358	<a href="#">Click here</a>	<a href="#">Click here</a>	<a href="#">Click here</a>	<a href="#">Click here</a>	<a href="#">Click here</a>

## 7.6 Community Resources

The following links connect to TI community resources. Linked contents are provided "AS IS" by the respective contributors. They do not constitute TI specifications and do not necessarily reflect TI's views; see TI's [Terms of Use](#).

### TI E2E™ Community

TI's *Engineer-to-Engineer (E2E) Community*. Created to foster collaboration among engineers. At [e2e.ti.com](http://e2e.ti.com), you can ask questions, share knowledge, explore ideas, and help solve problems with fellow engineers.

### TI Embedded Processors Wiki

*Texas Instruments Embedded Processors Wiki*. Established to help developers get started with embedded processors from Texas Instruments and to foster innovation and growth of general knowledge about the hardware and software surrounding these devices.

## 7.7 Trademarks

MicroStar Junior, MSP430, MSP430Ware, EnergyTrace, ULP Advisor, Code Composer Studio, E2E are trademarks of Texas Instruments.

All other trademarks are the property of their respective owners.

## 7.8 Electrostatic Discharge Caution



This integrated circuit can be damaged by ESD. Texas Instruments recommends that all integrated circuits be handled with appropriate precautions. Failure to observe proper handling and installation procedures can cause damage.

ESD damage can range from subtle performance degradation to complete device failure. Precision integrated circuits may be more susceptible to damage because very small parametric changes could cause the device not to meet its published specifications.

## 7.9 Export Control Notice

Recipient agrees to not knowingly export or re-export, directly or indirectly, any product or technical data (as defined by the U.S., EU, and other Export Administration Regulations) including software, or any controlled product restricted by other applicable national regulations, received from disclosing party under nondisclosure obligations (if any), or any direct product of such technology, to any destination to which such export or re-export is restricted or prohibited by U.S. or other applicable laws, without obtaining prior authorization from U.S. Department of Commerce and other competent Government authorities to the extent required by those laws.

## 7.10 Glossary

[TI Glossary](#) This glossary lists and explains terms, acronyms, and definitions.

## 8 Mechanical, Packaging, and Orderable Information

The following pages include mechanical, packaging, and orderable information. This information is the most current data available for the designated devices. This data is subject to change without notice and revision of this document. For browser-based versions of this data sheet, refer to the left-hand navigation.

**PACKAGING INFORMATION**

Orderable Device	Status (1)	Package Type	Package Drawing	Pins	Package Qty	Eco Plan (2)	Lead/Ball Finish (6)	MSL Peak Temp (3)	Op Temp (°C)	Device Marking (4/5)	Samples
MSP430F5358IPZ	ACTIVE	LQFP	PZ	100	90	Green (RoHS & no Sb/Br)	CU NIPDAU	Level-3-260C-168 HR	-40 to 85	F5358	<a href="#">Samples</a>
MSP430F5358IPZR	ACTIVE	LQFP	PZ	100	1000	Green (RoHS & no Sb/Br)	CU NIPDAU	Level-3-260C-168 HR	-40 to 85	F5358	<a href="#">Samples</a>
MSP430F5358IZQWR	ACTIVE	BGA MICROSTAR JUNIOR	ZQW	113	2500	Green (RoHS & no Sb/Br)	SNAGCU	Level-3-260C-168 HR	-40 to 85	F5358	<a href="#">Samples</a>
MSP430F5358IZQWT	ACTIVE	BGA MICROSTAR JUNIOR	ZQW	113	250	Green (RoHS & no Sb/Br)	SNAGCU	Level-3-260C-168 HR	-40 to 85	F5358	<a href="#">Samples</a>
MSP430F5359IPZ	ACTIVE	LQFP	PZ	100	90	Green (RoHS & no Sb/Br)	CU NIPDAU	Level-3-260C-168 HR	-40 to 85	F5359	<a href="#">Samples</a>
MSP430F5359IPZR	ACTIVE	LQFP	PZ	100	1000	Green (RoHS & no Sb/Br)	CU NIPDAU	Level-3-260C-168 HR	-40 to 85	F5359	<a href="#">Samples</a>
MSP430F5359IZQWR	ACTIVE	BGA MICROSTAR JUNIOR	ZQW	113	2500	Green (RoHS & no Sb/Br)	SNAGCU	Level-3-260C-168 HR	-40 to 85	F5359	<a href="#">Samples</a>
MSP430F5359IZQWT	ACTIVE	BGA MICROSTAR JUNIOR	ZQW	113	250	Green (RoHS & no Sb/Br)	SNAGCU	Level-3-260C-168 HR	-40 to 85	F5359	<a href="#">Samples</a>
MSP430F5658IPZ	ACTIVE	LQFP	PZ	100	90	Green (RoHS & no Sb/Br)	CU NIPDAU	Level-3-260C-168 HR	-40 to 85	F5658	<a href="#">Samples</a>
MSP430F5658IPZR	ACTIVE	LQFP	PZ	100	1000	Green (RoHS & no Sb/Br)	CU NIPDAU	Level-3-260C-168 HR	-40 to 85	F5658	<a href="#">Samples</a>
MSP430F5658IZQWR	ACTIVE	BGA MICROSTAR JUNIOR	ZQW	113	2500	Green (RoHS & no Sb/Br)	SNAGCU	Level-3-260C-168 HR	-40 to 85	F5658	<a href="#">Samples</a>
MSP430F5658IZQWT	ACTIVE	BGA MICROSTAR JUNIOR	ZQW	113	250	Green (RoHS & no Sb/Br)	SNAGCU	Level-3-260C-168 HR	-40 to 85	F5658	<a href="#">Samples</a>
MSP430F5659IPZ	ACTIVE	LQFP	PZ	100	90	Green (RoHS & no Sb/Br)	CU NIPDAU	Level-3-260C-168 HR	-40 to 85	F5659	<a href="#">Samples</a>
MSP430F5659IPZR	ACTIVE	LQFP	PZ	100	1000	Green (RoHS & no Sb/Br)	CU NIPDAU	Level-3-260C-168 HR	-40 to 85	F5659	<a href="#">Samples</a>

Orderable Device	Status (1)	Package Type	Package Drawing	Pins	Package Qty	Eco Plan (2)	Lead/Ball Finish (6)	MSL Peak Temp (3)	Op Temp (°C)	Device Marking (4/5)	Samples
MSP430F5659IZQWR	ACTIVE	BGA MICROSTAR JUNIOR	ZQW	113	2500	Green (RoHS & no Sb/Br)	SNAGCU	Level-3-260C-168 HR	-40 to 85	F5659	<a href="#">Samples</a>
MSP430F5659IZQWT	ACTIVE	BGA MICROSTAR JUNIOR	ZQW	113	250	Green (RoHS & no Sb/Br)	SNAGCU	Level-3-260C-168 HR	-40 to 85	F5659	<a href="#">Samples</a>
MSP430F6458IPZ	ACTIVE	LQFP	PZ	100	90	Green (RoHS & no Sb/Br)	CU NIPDAU	Level-3-260C-168 HR	-40 to 85	F6458	<a href="#">Samples</a>
MSP430F6459IPZ	ACTIVE	LQFP	PZ	100	90	Green (RoHS & no Sb/Br)	CU NIPDAU	Level-3-260C-168 HR	-40 to 85	F6459	<a href="#">Samples</a>
MSP430F6459IPZR	ACTIVE	LQFP	PZ	100	1000	Green (RoHS & no Sb/Br)	CU NIPDAU	Level-3-260C-168 HR	-40 to 85	F6459	<a href="#">Samples</a>
MSP430F6459IZQWT	ACTIVE	BGA MICROSTAR JUNIOR	ZQW	113	250	Green (RoHS & no Sb/Br)	SNAGCU	Level-3-260C-168 HR	-40 to 85	F6459	<a href="#">Samples</a>
MSP430F6658IPZ	ACTIVE	LQFP	PZ	100	90	Green (RoHS & no Sb/Br)	CU NIPDAU	Level-3-260C-168 HR	-40 to 85	F6658	<a href="#">Samples</a>
MSP430F6659IPZ	ACTIVE	LQFP	PZ	100	90	Green (RoHS & no Sb/Br)	CU NIPDAU	Level-3-260C-168 HR	-40 to 85	F6659	<a href="#">Samples</a>
MSP430F6659IPZR	ACTIVE	LQFP	PZ	100	1000	Green (RoHS & no Sb/Br)	CU NIPDAU	Level-3-260C-168 HR	-40 to 85	F6659	<a href="#">Samples</a>
MSP430F6659IZQWR	ACTIVE	BGA MICROSTAR JUNIOR	ZQW	113	2500	Green (RoHS & no Sb/Br)	SNAGCU	Level-3-260C-168 HR	-40 to 85	F6659	<a href="#">Samples</a>
MSP430F6659IZQWT	ACTIVE	BGA MICROSTAR JUNIOR	ZQW	113	250	Green (RoHS & no Sb/Br)	SNAGCU	Level-3-260C-168 HR	-40 to 85	F6659	<a href="#">Samples</a>

(1) The marketing status values are defined as follows:

**ACTIVE:** Product device recommended for new designs.

**LIFEBUY:** TI has announced that the device will be discontinued, and a lifetime-buy period is in effect.

**NRND:** Not recommended for new designs. Device is in production to support existing customers, but TI does not recommend using this part in a new design.

**PREVIEW:** Device has been announced but is not in production. Samples may or may not be available.

**OBSELETE:** TI has discontinued the production of the device.

(2) **RoHS:** TI defines "RoHS" to mean semiconductor products that are compliant with the current EU RoHS requirements for all 10 RoHS substances, including the requirement that RoHS substance do not exceed 0.1% by weight in homogeneous materials. Where designed to be soldered at high temperatures, "RoHS" products are suitable for use in specified lead-free processes. TI may reference these types of products as "Pb-Free".

---

**RoHS Exempt:** TI defines "RoHS Exempt" to mean products that contain lead but are compliant with EU RoHS pursuant to a specific EU RoHS exemption.

**Green:** TI defines "Green" to mean the content of Chlorine (Cl) and Bromine (Br) based flame retardants meet JS709B low halogen requirements of  $\leq 1000$ ppm threshold. Antimony trioxide based flame retardants must also meet the  $\leq 1000$ ppm threshold requirement.

(3) MSL, Peak Temp. - The Moisture Sensitivity Level rating according to the JEDEC industry standard classifications, and peak solder temperature.

(4) There may be additional marking, which relates to the logo, the lot trace code information, or the environmental category on the device.

(5) Multiple Device Markings will be inside parentheses. Only one Device Marking contained in parentheses and separated by a "~" will appear on a device. If a line is indented then it is a continuation of the previous line and the two combined represent the entire Device Marking for that device.

(6) Lead/Ball Finish - Orderable Devices may have multiple material finish options. Finish options are separated by a vertical ruled line. Lead/Ball Finish values may wrap to two lines if the finish value exceeds the maximum column width.

**Important Information and Disclaimer:** The information provided on this page represents TI's knowledge and belief as of the date that it is provided. TI bases its knowledge and belief on information provided by third parties, and makes no representation or warranty as to the accuracy of such information. Efforts are underway to better integrate information from third parties. TI has taken and continues to take reasonable steps to provide representative and accurate information but may not have conducted destructive testing or chemical analysis on incoming materials and chemicals. TI and TI suppliers consider certain information to be proprietary, and thus CAS numbers and other limited information may not be available for release.

In no event shall TI's liability arising out of such information exceed the total purchase price of the TI part(s) at issue in this document sold by TI to Customer on an annual basis.

## TAPE AND REEL INFORMATION

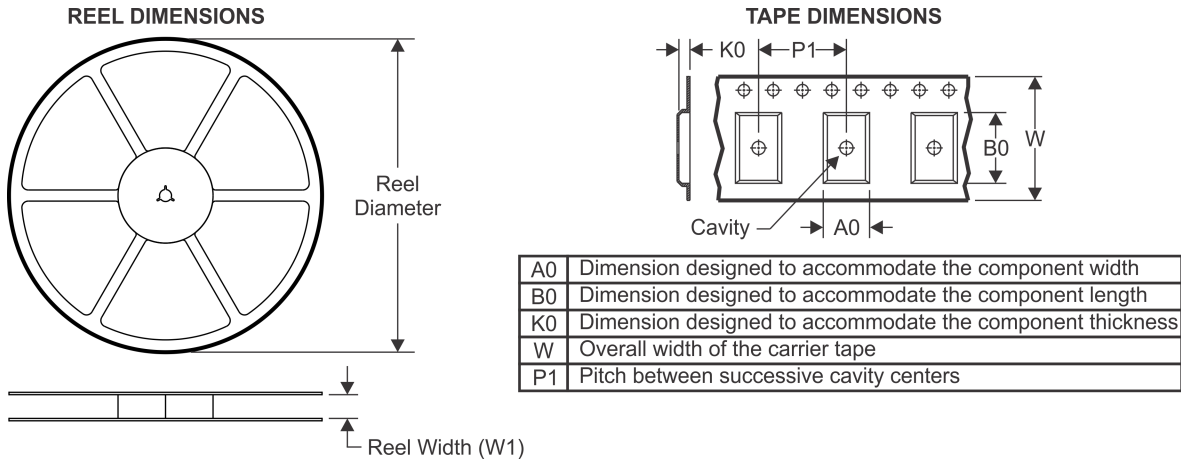

### QUADRANT ASSIGNMENTS FOR PIN 1 ORIENTATION IN TAPE

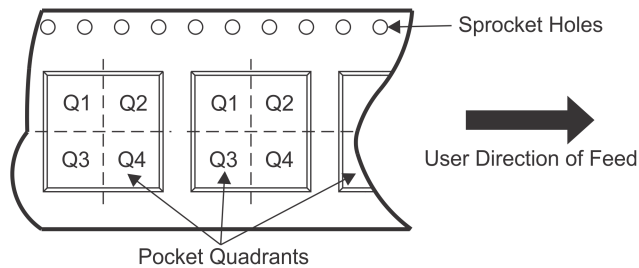

\*All dimensions are nominal

Device	Package Type	Package Drawing	Pins	SPQ	Reel Diameter (mm)	Reel Width W1 (mm)	A0 (mm)	B0 (mm)	K0 (mm)	P1 (mm)	W (mm)	Pin1 Quadrant
MSP430F5358IPZR	LQFP	PZ	100	1000	330.0	24.4	17.0	17.0	2.1	20.0	24.0	Q2
MSP430F5358IQWR	BGA MICROSTAR JUNIOR	ZQW	113	2500	330.0	16.4	7.3	7.3	1.5	12.0	16.0	Q1
MSP430F5358IQWT	BGA MICROSTAR JUNIOR	ZQW	113	250	180.0	16.4	7.3	7.3	1.5	12.0	16.0	Q1
MSP430F5359IPZR	LQFP	PZ	100	1000	330.0	24.4	17.0	17.0	2.1	20.0	24.0	Q2
MSP430F5359IQWR	BGA MICROSTAR JUNIOR	ZQW	113	2500	330.0	16.4	7.3	7.3	1.5	12.0	16.0	Q1
MSP430F5359IQWT	BGA MICROSTAR JUNIOR	ZQW	113	250	180.0	16.4	7.3	7.3	1.5	12.0	16.0	Q1
MSP430F5658IPZR	LQFP	PZ	100	1000	330.0	24.4	17.0	17.0	2.1	20.0	24.0	Q2
MSP430F5658IQWR	BGA MICROSTAR JUNIOR	ZQW	113	2500	330.0	16.4	7.3	7.3	1.5	12.0	16.0	Q1

Device	Package Type	Package Drawing	Pins	SPQ	Reel Diameter (mm)	Reel Width W1 (mm)	A0 (mm)	B0 (mm)	K0 (mm)	P1 (mm)	W (mm)	Pin1 Quadrant
	OR											
MSP430F5658IZQWT	BGA MI CROSTA R JUNI OR	ZQW	113	250	180.0	16.4	7.3	7.3	1.5	12.0	16.0	Q1
MSP430F5659IPZR	LQFP	PZ	100	1000	330.0	24.4	17.0	17.0	2.1	20.0	24.0	Q2
MSP430F5659IZQWR	BGA MI CROSTA R JUNI OR	ZQW	113	2500	330.0	16.4	7.3	7.3	1.5	12.0	16.0	Q1
MSP430F5659IZQWT	BGA MI CROSTA R JUNI OR	ZQW	113	250	180.0	16.4	7.3	7.3	1.5	12.0	16.0	Q1
MSP430F6459IPZR	LQFP	PZ	100	1000	330.0	24.4	17.0	17.0	2.1	20.0	24.0	Q2
MSP430F6459IZQWT	BGA MI CROSTA R JUNI OR	ZQW	113	250	180.0	16.4	7.3	7.3	1.5	12.0	16.0	Q1
MSP430F6659IPZR	LQFP	PZ	100	1000	330.0	24.4	17.0	17.0	2.1	20.0	24.0	Q2
MSP430F6659IZQWR	BGA MI CROSTA R JUNI OR	ZQW	113	2500	330.0	16.4	7.3	7.3	1.5	12.0	16.0	Q1
MSP430F6659IZQWT	BGA MI CROSTA R JUNI OR	ZQW	113	250	180.0	16.4	7.3	7.3	1.5	12.0	16.0	Q1

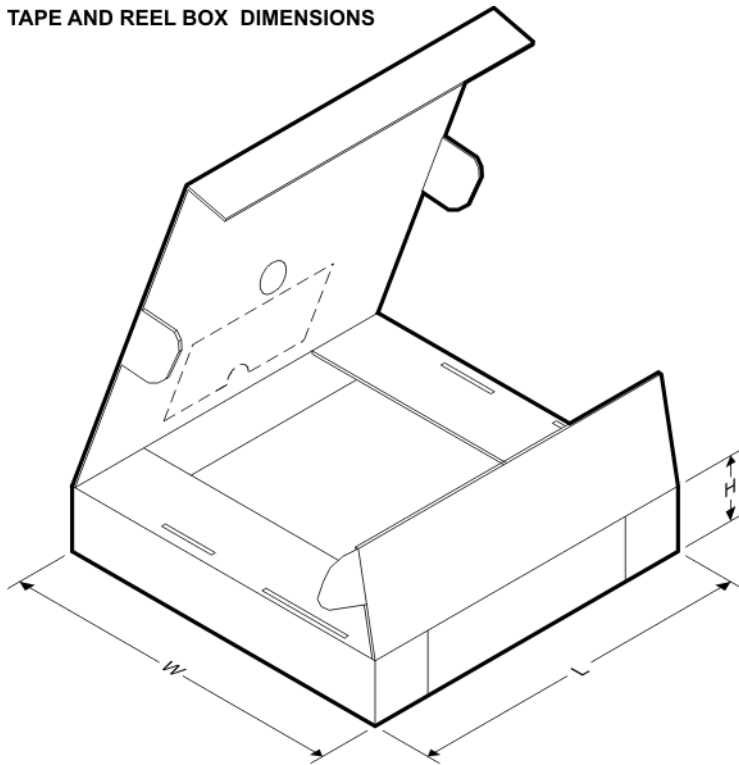
**TAPE AND REEL BOX DIMENSIONS**

\*All dimensions are nominal

Device	Package Type	Package Drawing	Pins	SPQ	Length (mm)	Width (mm)	Height (mm)
MSP430F5358IPZR	LQFP	PZ	100	1000	350.0	350.0	43.0
MSP430F5358IZQWR	BGA MICROSTAR JUNIOR	ZQW	113	2500	350.0	350.0	43.0
MSP430F5358IZQWT	BGA MICROSTAR JUNIOR	ZQW	113	250	213.0	191.0	55.0
MSP430F5359IPZR	LQFP	PZ	100	1000	350.0	350.0	43.0
MSP430F5359IZQWR	BGA MICROSTAR JUNIOR	ZQW	113	2500	350.0	350.0	43.0
MSP430F5359IZQWT	BGA MICROSTAR JUNIOR	ZQW	113	250	213.0	191.0	55.0
MSP430F5658IPZR	LQFP	PZ	100	1000	350.0	350.0	43.0
MSP430F5658IZQWR	BGA MICROSTAR JUNIOR	ZQW	113	2500	350.0	350.0	43.0
MSP430F5658IZQWT	BGA MICROSTAR JUNIOR	ZQW	113	250	213.0	191.0	55.0
MSP430F5659IPZR	LQFP	PZ	100	1000	350.0	350.0	43.0
MSP430F5659IZQWR	BGA MICROSTAR JUNIOR	ZQW	113	2500	350.0	350.0	43.0
MSP430F5659IZQWT	BGA MICROSTAR JUNIOR	ZQW	113	250	213.0	191.0	55.0
MSP430F6459IPZR	LQFP	PZ	100	1000	350.0	350.0	43.0
MSP430F6459IZQWT	BGA MICROSTAR JUNIOR	ZQW	113	250	213.0	191.0	55.0

---

Device	Package Type	Package Drawing	Pins	SPQ	Length (mm)	Width (mm)	Height (mm)
MSP430F6659IPZR	LQFP	PZ	100	1000	350.0	350.0	43.0
MSP430F6659IZQWR	BGA MICROSTAR JUNIOR	ZQW	113	2500	350.0	350.0	43.0
MSP430F6659IZQWT	BGA MICROSTAR JUNIOR	ZQW	113	250	213.0	191.0	55.0

PZ (S-PQFP-G100)

PLASTIC QUAD FLATPACK

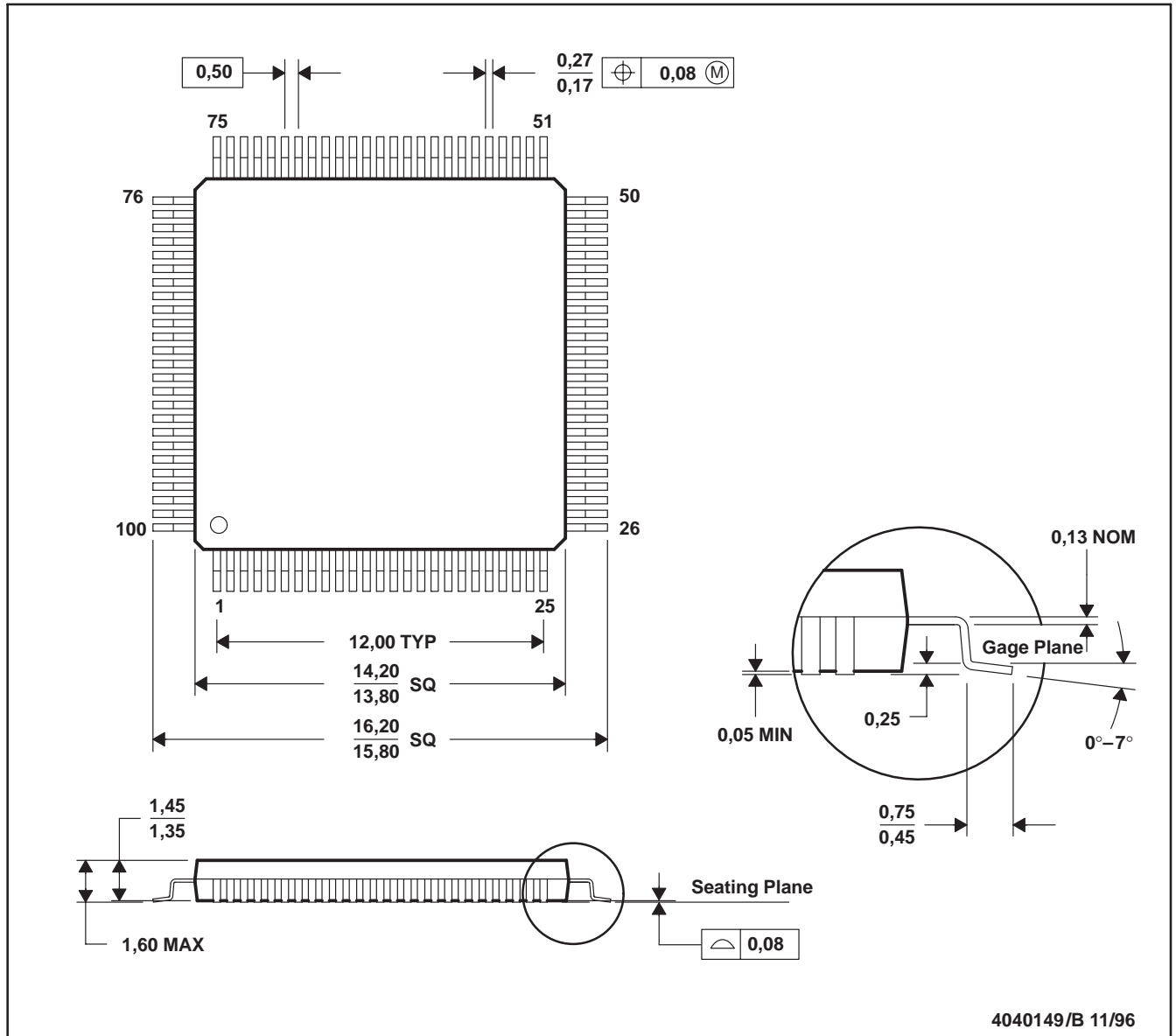

- NOTES: A. All linear dimensions are in millimeters.  
 B. This drawing is subject to change without notice.  
 C. Falls within JEDEC MS-026

PZ (S-PQFP-G100)

PLASTIC QUAD FLAT PACK

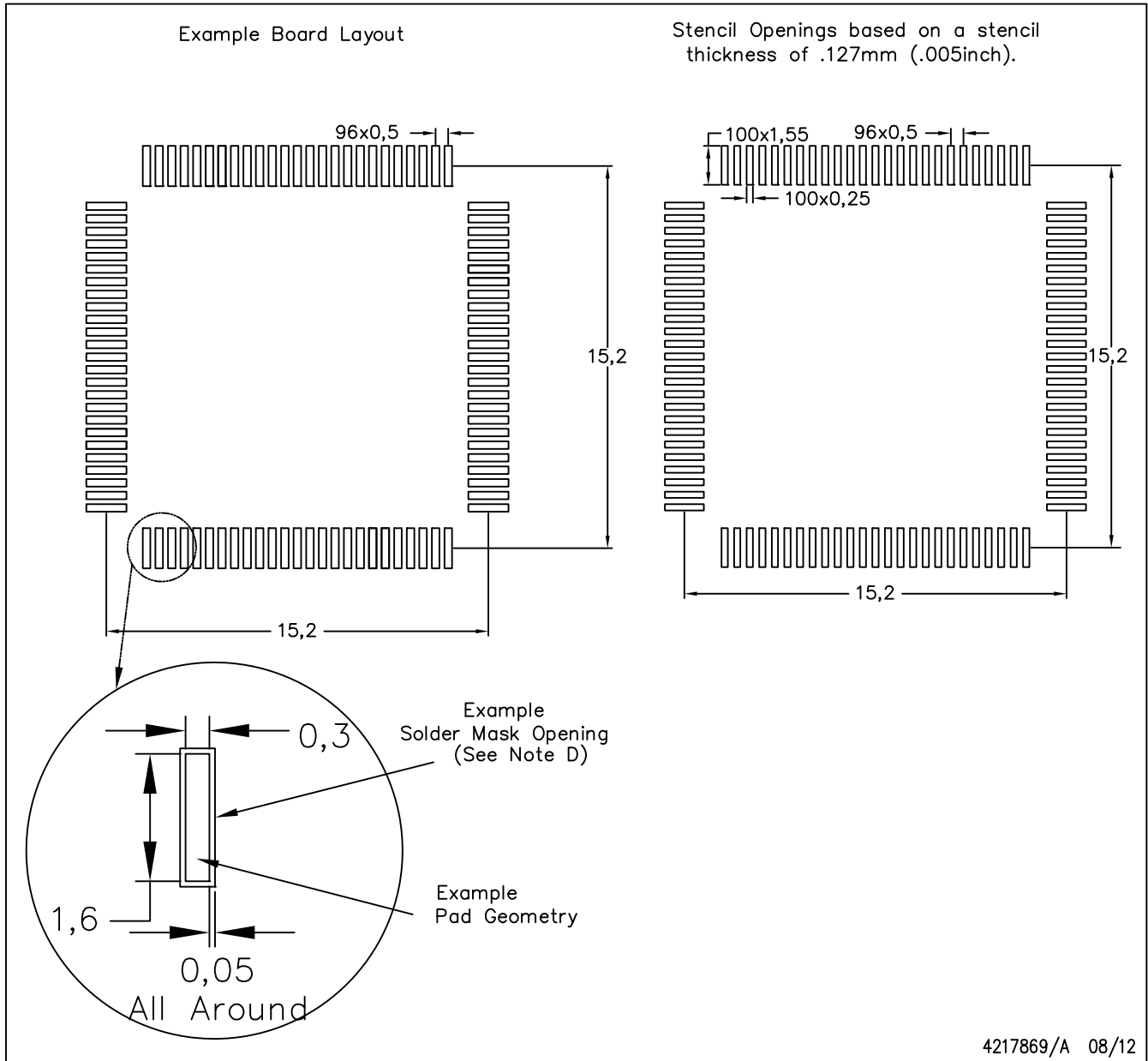

NOTES:

- A. All linear dimensions are in millimeters.
- B. This drawing is subject to change without notice.
- C. Laser cutting apertures with trapezoidal walls and also rounding corners will offer better paste release. Customers should contact their board assembly site for stencil design recommendations. Example stencil design based on a 50% volumetric metal load solder paste. Refer to IPC-7525 for other stencil recommendations.
- D. Customers should contact their board fabrication site for solder mask tolerances between and around signal pads.



## IMPORTANT NOTICE AND DISCLAIMER

TI PROVIDES TECHNICAL AND RELIABILITY DATA (INCLUDING DATASHEETS), DESIGN RESOURCES (INCLUDING REFERENCE DESIGNS), APPLICATION OR OTHER DESIGN ADVICE, WEB TOOLS, SAFETY INFORMATION, AND OTHER RESOURCES "AS IS" AND WITH ALL FAULTS, AND DISCLAIMS ALL WARRANTIES, EXPRESS AND IMPLIED, INCLUDING WITHOUT LIMITATION ANY IMPLIED WARRANTIES OF MERCHANTABILITY, FITNESS FOR A PARTICULAR PURPOSE OR NON-INFRINGEMENT OF THIRD PARTY INTELLECTUAL PROPERTY RIGHTS.

These resources are intended for skilled developers designing with TI products. You are solely responsible for (1) selecting the appropriate TI products for your application, (2) designing, validating and testing your application, and (3) ensuring your application meets applicable standards, and any other safety, security, or other requirements. These resources are subject to change without notice. TI grants you permission to use these resources only for development of an application that uses the TI products described in the resource. Other reproduction and display of these resources is prohibited. No license is granted to any other TI intellectual property right or to any third party intellectual property right. TI disclaims responsibility for, and you will fully indemnify TI and its representatives against, any claims, damages, costs, losses, and liabilities arising out of your use of these resources.

TI's products are provided subject to TI's Terms of Sale ([www.ti.com/legal/termsofsale.html](http://www.ti.com/legal/termsofsale.html)) or other applicable terms available either on [ti.com](http://ti.com) or provided in conjunction with such TI products. TI's provision of these resources does not expand or otherwise alter TI's applicable warranties or warranty disclaimers for TI products.

Mailing Address: Texas Instruments, Post Office Box 655303, Dallas, Texas 75265  
Copyright © 2019, Texas Instruments Incorporated

## Looking for pricing, stock, or lifecycle information?

Click below to explore more details on WIN SOURCE:

 [View MSP430F5658IPZR on WIN SOURCE](#)

 [Texas Instruments](#) Information

## Optimize Your Supply Chain with WIN SOURCE Solutions

-  Global Sourcing Solution
-  Obsolete Management
-  Cost Control Management
-  Shortage Management
-  Alternative Solution
-  Excess Inventory Management