



**THE DATASHEET OF
MSP430F5328TRGCTEP**



MIXED SIGNAL MICROCONTROLLER

FEATURES

- **Low Supply Voltage Range:**
3.6 V Down to 1.8 V
- **Ultralow Power Consumption**
 - **Active Mode (AM):**
All System Clocks Active
290 μ A/MHz at 8 MHz, 3 V, Flash Program Execution (Typical)
150 μ A/MHz at 8 MHz, 3 V, RAM Program Execution (Typical)
 - **Standby Mode (LPM3):**
Real-Time Clock With Crystal, Watchdog, and Supply Supervisor Operational, Full RAM Retention, Fast Wake-Up:
1.9 μ A at 2.2 V, 2.1 μ A at 3 V (Typical)
Low-Power Oscillator (VLO), General Purpose Counter, Watchdog, and Supply Supervisor Operational, Full RAM Retention, Fast Wake-Up:
1.4 μ A at 3 V (Typical)
 - **Off Mode (LPM4):**
Full RAM Retention, Supply Supervisor Operational, Fast Wake-Up:
1.1 μ A at 3 V (Typical)
 - **Shutdown Mode (LPM4.5):**
0.18 μ A at 3 V (Typical)
- **Wake-Up From Standby Mode in 3.5 μ s (Typical)**
- **16-Bit RISC Architecture, Extended Memory, Up to 25-MHz System Clock**
- **Flexible Power Management System**
 - Fully Integrated LDO With Programmable Regulated Core Supply Voltage
 - Supply Voltage Supervision, Monitoring, and Brownout
- **Unified Clock System**
 - FLL Control Loop for Frequency Stabilization
 - Low-Power Low-Frequency Internal Clock Source (VLO)
 - Low-Frequency Trimmed Internal Reference Source (REFO)
 - 32-kHz Watch Crystals (XT1)
 - High-Frequency Crystals Up to 32 MHz (XT2)
- **16-Bit Timer TA0, Timer_A With Five Capture/Compare Registers**
- **16-Bit Timer TA1, Timer_A With Three Capture/Compare Registers**
- **16-Bit Timer TA2, Timer_A With Three Capture/Compare Registers**
- **16-Bit Timer TB0, Timer_B With Seven Capture/Compare Shadow Registers**
- **Two Universal Serial Communication Interfaces**
 - USCI_A0 and USCI_A1 Each Support:
 - Enhanced UART Supports Auto-Baudrate Detection
 - IrDA Encoder and Decoder
 - Synchronous SPI
 - USCI_B0 and USCI_B1 Each Support:
 - I²C™
 - Synchronous SPI
- **Integrated 3.3-V Power System**
- **12-Bit Analog-to-Digital (A/D) Converter With Internal Reference, Sample-and-Hold, and Autoscan Feature**
- **Comparator**
- **Hardware Multiplier Supporting 32-Bit Operations**
- **Serial Onboard Programming, No External Programming Voltage Needed**
- **Three Channel Internal DMA**
- **Basic Timer With Real-Time Clock Feature**
- **Family Members are Summarized in**
- **For Complete Module Descriptions, See the *MSP430x5xx and MSP430x6xx Family User's Guide (SLAU208)***
- **Controlled Baseline**
- **One Assembly and Test Site**
- **One Fabrication Site**
- **Wide operational temperature range of –40°C to +105°C (some noted parameters specified for –40°C to +85°C only)**
- **Extended Product Life Cycle**
- **Extended Product-Change Notification**
- **Product Traceability**



Please be aware that an important notice concerning availability, standard warranty, and use in critical applications of Texas Instruments semiconductor products and disclaimers thereto appears at the end of this data sheet.

All trademarks are the property of their respective owners.

DESCRIPTION

The MSP430F5328's architecture, combined with extensive low-power modes is optimized to achieve extended battery life in portable measurement applications. The device features a powerful 16-bit RISC CPU, 16-bit registers, and constant generators that contribute to maximum code efficiency. The digitally controlled oscillator (DCO) allows wake-up from low-power modes to active mode in 3.5 μ s (typical).

The MSP430F5328 is a microcontroller configuration with an integrated 3.3-V LDO, four 16-bit timers, a high-performance 12-bit analog-to-digital converter (ADC), two universal serial communication interfaces (USCI), hardware multiplier, DMA, real-time clock module with alarm capabilities, and 47 I/O pins.

Typical applications include analog and digital sensor systems, data loggers, and various general-purpose applications.

ORDERING INFORMATION⁽¹⁾

| T _J | PACKAGE | ORDERABLE PART NUMBER | TOP-SIDE MARKING | VID NUMBER |
|----------------|------------|-----------------------|------------------|----------------|
| -40°C to 105°C | VQFN - RGC | MSP430F5328TRGCTEP | M4F5328T | V62/13628-01XE |

- (1) For the most current package and ordering information, see the Package Option Addendum at the end of this document, or see the TI website at www.ti.com.

Functional Block Diagram

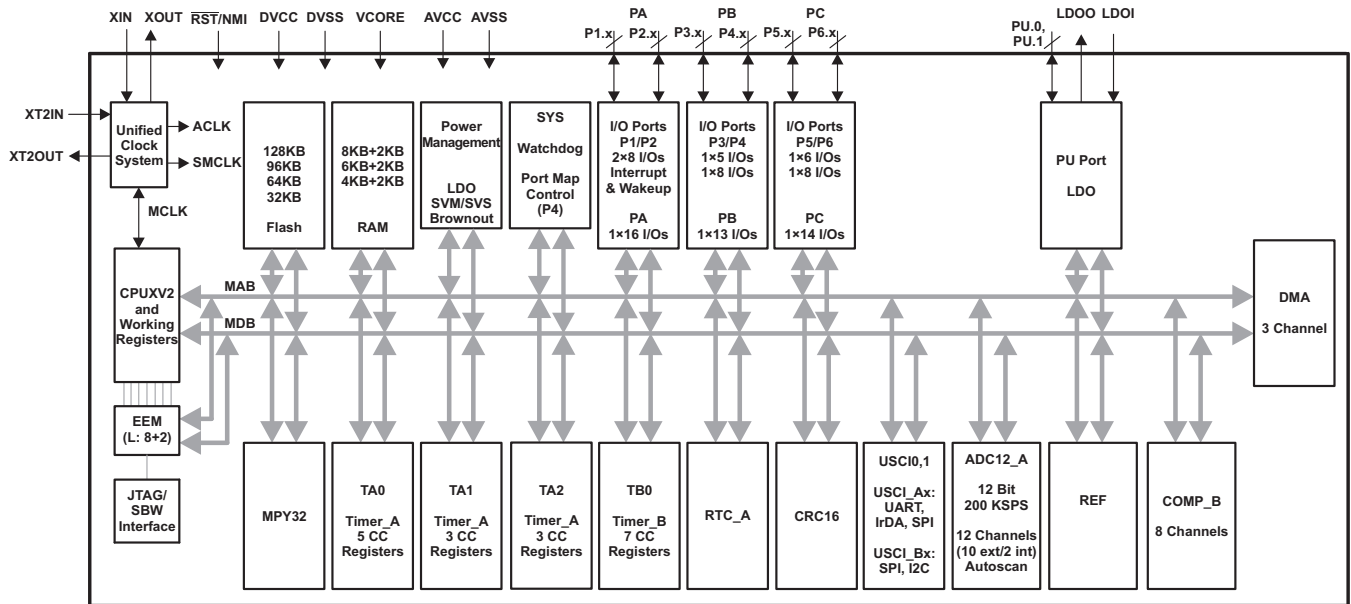

Pin Designation

RGC PACKAGE
(TOP VIEW)

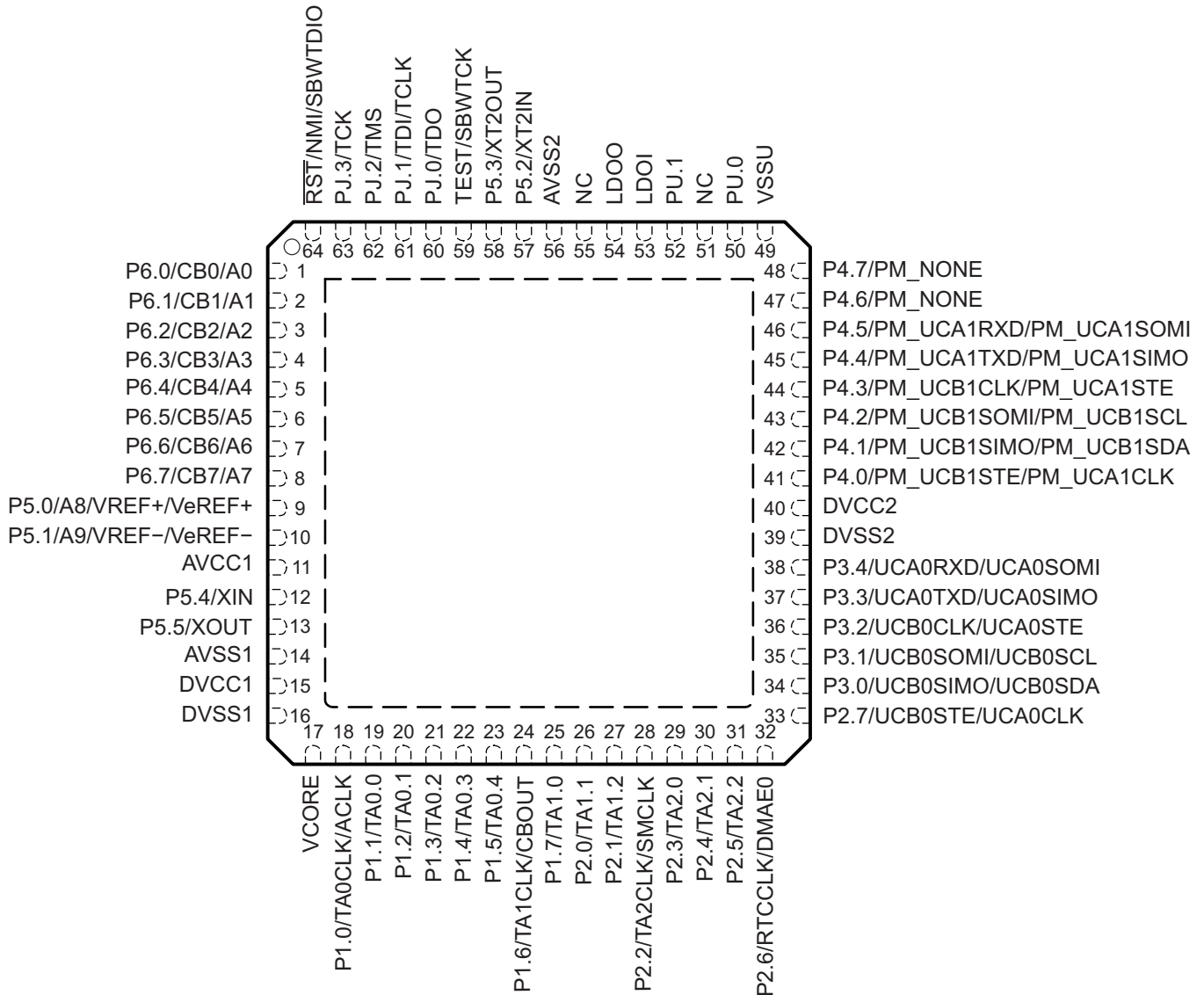

Table 1. Terminal Functions

| TERMINAL | | I/O ⁽¹⁾ | DESCRIPTION |
|----------------------|------------|--------------------|--|
| NAME | NO. RGC | | |
| P6.4/CB4/A4 | 5 | I/O | General-purpose digital I/O Comparator_B input CB4 Analog input A4 – ADC |
| P6.5/CB5/A5 | 6 | I/O | General-purpose digital I/O Comparator_B input CB5 Analog input A5 – ADC |
| P6.6/CB6/A6 | 7 | I/O | General-purpose digital I/O Comparator_B input CB6 Analog input A6 – ADC |
| P6.7/CB7/A7 | 8 | I/O | General-purpose digital I/O Comparator_B input CB7 Analog input A7 – ADC |
| P5.0/A8/VREF+/VeREF+ | 9 | I/O | General-purpose digital I/O Analog input A8 – ADC Output of reference voltage to the ADC Input for an external reference voltage to the ADC |
| P5.1/A9/VREF-/VeREF- | 10 | I/O | General-purpose digital I/O Analog input A9 – ADC Negative terminal for the ADC's reference voltage for both sources, the internal reference voltage, or an external applied reference voltage |
| AVCC1 | 11 | | Analog power supply |
| P5.4/XIN | 12 | I/O | General-purpose digital I/O Input terminal for crystal oscillator XT1 |
| P5.5/XOUT | 13 | I/O | General-purpose digital I/O Output terminal of crystal oscillator XT1 |
| AVSS1 | 14 | | Analog ground supply |
| DVCC1 | 15 | | Digital power supply |
| DVSS1 | 16 | | Digital ground supply |
| VCORE ⁽²⁾ | 17 | | Regulated core power supply output (internal use only, no external current loading) |
| P1.0/TA0CLK/ACLK | 18 | I/O | General-purpose digital I/O with port interrupt TA0 clock signal TA0CLK input ACLK output (divided by 1, 2, 4, 8, 16, or 32) |
| P1.1/TA0.0 | 19 | I/O | General-purpose digital I/O with port interrupt TA0 CCR0 capture: CCI0A input, compare: Out0 output BSL transmit output |
| P1.2/TA0.1 | 20 | I/O | General-purpose digital I/O with port interrupt TA0 CCR1 capture: CCI1A input, compare: Out1 output BSL receive input |
| P1.3/TA0.2 | 21 | I/O | General-purpose digital I/O with port interrupt TA0 CCR2 capture: CCI2A input, compare: Out2 output |
| P1.4/TA0.3 | 22 | I/O | General-purpose digital I/O with port interrupt TA0 CCR3 capture: CCI3A input compare: Out3 output |

(1) I = input, O = output, N/A = not available

(2) V_{CORE} is for internal use only. No external current loading is possible. V_{CORE} should only be connected to the recommended capacitor value, C_{V_{CORE}}.

Table 1. Terminal Functions (continued)

| TERMINAL | | I/O ⁽¹⁾ | DESCRIPTION |
|---------------------------|------------|--------------------|---|
| NAME | NO. RGC | | |
| P1.5/TA0.4 | 23 | I/O | General-purpose digital I/O with port interrupt TA0 CCR4 capture: CCI4A input, compare: Out4 output |
| P1.6/TA1CLK/CBOUT | 24 | I/O | General-purpose digital I/O with port interrupt TA1 clock signal TA1CLK input Comparator_B output |
| P1.7/TA1.0 | 25 | I/O | General-purpose digital I/O with port interrupt TA1 CCR0 capture: CCI0A input, compare: Out0 output |
| P2.0/TA1.1 | 26 | I/O | General-purpose digital I/O with port interrupt TA1 CCR1 capture: CCI1A input, compare: Out1 output |
| P2.1/TA1.2 | 27 | I/O | General-purpose digital I/O with port interrupt TA1 CCR2 capture: CCI2A input, compare: Out2 output |
| P2.2/TA2CLK/SMCLK | 28 | I/O | General-purpose digital I/O with port interrupt TA2 clock signal TA2CLK input ; SMCLK output |
| P2.3/TA2.0 | 29 | I/O | General-purpose digital I/O with port interrupt TA2 CCR0 capture: CCI0A input, compare: Out0 output |
| P2.4/TA2.1 | 30 | I/O | General-purpose digital I/O with port interrupt TA2 CCR1 capture: CCI1A input, compare: Out1 output |
| P2.5/TA2.2 | 31 | I/O | General-purpose digital I/O with port interrupt TA2 CCR2 capture: CCI2A input, compare: Out2 output |
| P2.6/RTCCLK/DMAE0 | 32 | I/O | General-purpose digital I/O with port interrupt RTC clock output for calibration DMA external trigger input |
| P2.7/UCB0STE/ UCA0CLK | 33 | I/O | General-purpose digital I/O with port interrupt Slave transmit enable – USCI_B0 SPI mode Clock signal input – USCI_A0 SPI slave mode Clock signal output – USCI_A0 SPI master mode |
| P3.0/UCB0SIMO/ UCB0SDA | 34 | I/O | General-purpose digital I/O Slave in, master out – USCI_B0 SPI mode I2C data – USCI_B0 I2C mode |
| P3.1/UCB0SOMI/ UCB0SCL | 35 | I/O | General-purpose digital I/O Slave out, master in – USCI_B0 SPI mode I2C clock – USCI_B0 I2C mode |
| P3.2/UCB0CLK/ UCA0STE | 36 | I/O | General-purpose digital I/O Clock signal input – USCI_B0 SPI slave mode Clock signal output – USCI_B0 SPI master mode Slave transmit enable – USCI_A0 SPI mode |
| P3.3/UCA0TXD/ UCA0SIMO | 37 | I/O | General-purpose digital I/O Transmit data – USCI_A0 UART mode Slave in, master out – USCI_A0 SPI mode |
| P3.4/UCA0RXD/ UCA0SOMI | 38 | I/O | General-purpose digital I/O Receive data – USCI_A0 UART mode Slave out, master in – USCI_A0 SPI mode |

Table 1. Terminal Functions (continued)

| TERMINAL | | I/O ⁽¹⁾ | DESCRIPTION |
|---------------------------------|------------|--------------------|--|
| NAME | NO. RGC | | |
| P4.0/PM_UCB1STE/ PM_UCA1CLK | 41 | I/O | General-purpose digital I/O with reconfigurable port mapping secondary function Default mapping: Slave transmit enable – USCI_B1 SPI mode Default mapping: Clock signal input – USCI_A1 SPI slave mode Default mapping: Clock signal output – USCI_A1 SPI master mode |
| P4.1/PM_UCB1SIMO/ PM_UCB1SDA | 42 | I/O | General-purpose digital I/O with reconfigurable port mapping secondary function Default mapping: Slave in, master out – USCI_B1 SPI mode Default mapping: I2C data – USCI_B1 I2C mode |
| P4.2/PM_UCB1SOMI/ PM_UCB1SCL | 43 | I/O | General-purpose digital I/O with reconfigurable port mapping secondary function Default mapping: Slave out, master in – USCI_B1 SPI mode Default mapping: I2C clock – USCI_B1 I2C mode |
| P4.3/PM_UCB1CLK/ PM_UCA1STE | 44 | I/O | General-purpose digital I/O with reconfigurable port mapping secondary function Default mapping: Clock signal input – USCI_B1 SPI slave mode Default mapping: Clock signal output – USCI_B1 SPI master mode Default mapping: Slave transmit enable – USCI_A1 SPI mode |
| DVSS2 | 39 | | Digital ground supply |
| DVCC2 | 40 | | Digital power supply |
| P4.4/PM_UCA1TXD/ PM_UCA1SIMO | 45 | I/O | General-purpose digital I/O with reconfigurable port mapping secondary function Default mapping: Transmit data – USCI_A1 UART mode Default mapping: Slave in, master out – USCI_A1 SPI mode |
| P4.5/PM_UCA1RXD/ PM_UCA1SOMI | 46 | I/O | General-purpose digital I/O with reconfigurable port mapping secondary function Default mapping: Receive data – USCI_A1 UART mode Default mapping: Slave out, master in – USCI_A1 SPI mode |
| P4.6/PM_NONE | 47 | I/O | General-purpose digital I/O with reconfigurable port mapping secondary function Default mapping: no secondary function. |
| P4.7/PM_NONE | 48 | I/O | General-purpose digital I/O with reconfigurable port mapping secondary function Default mapping: no secondary function. |
| VSSU | 49 | | PU ground supply |
| PU.0 | 50 | I/O | General-purpose digital I/O - controlled by PU control register |
| NC | 51 | I/O | No connect |
| PU.1 | 52 | I/O | General-purpose digital I/O - controlled by PU control register |
| LDOI | 53 | | LDO input |
| LDOO | 54 | | LDO output |
| NC | 55 | | No connect |
| AVSS2 | 56 | | Analog ground supply |
| P5.2/XT2IN | 57 | I/O | General-purpose digital I/O Input terminal for crystal oscillator XT2 |
| P5.3/XT2OUT | 58 | I/O | General-purpose digital I/O Output terminal of crystal oscillator XT2 |
| TEST/SBWTCK ⁽³⁾ | 59 | I | Test mode pin – Selects four wire JTAG operation. Spy-Bi-Wire input clock when Spy-Bi-Wire operation activated |
| PJ.0/TDO ⁽⁴⁾ | 60 | I/O | General-purpose digital I/O JTAG test data output port |

(3) See [Bootstrap Loader \(BSL\)](#) and [JTAG Operation](#) for use with BSL and JTAG functions

(4) See [JTAG Operation](#) for usage with JTAG function.

Table 1. Terminal Functions (continued)

| TERMINAL | | I/O ⁽¹⁾ | DESCRIPTION |
|---|------------|--------------------|---|
| NAME | NO. RGC | | |
| PJ.1/TDI/TCLK ⁽⁴⁾ | 61 | I/O | General-purpose digital I/O JTAG test data input or test clock input |
| PJ.2/TMS ⁽⁴⁾ | 62 | I/O | General-purpose digital I/O JTAG test mode select |
| PJ.3/TCK ⁽⁴⁾ | 63 | I/O | General-purpose digital I/O JTAG test clock |
| $\overline{\text{RST}}$ /NMI/SBWTDIO ⁽³⁾ | 64 | I/O | Reset input active low Non-maskable interrupt input Spy-Bi-Wire data input/output when Spy-Bi-Wire operation activated. |
| P6.0/CB0/A0 | 1 | I/O | General-purpose digital I/O Comparator_B input CB0 Analog input A0 – ADC |
| P6.1/CB1/A1 | 2 | I/O | General-purpose digital I/O Comparator_B input CB1 Analog input A1 – ADC |
| P6.2/CB2/A2 | 3 | I/O | General-purpose digital I/O Comparator_B input CB2 Analog input A2 – ADC |
| P6.3/CB3/A3 | 4 | I/O | General-purpose digital I/O Comparator_B input CB3 Analog input A3 – ADC |

SHORT-FORM DESCRIPTION

CPU ([Link to User's Guide](#))

The MSP430 CPU has a 16-bit RISC architecture that is highly transparent to the application. All operations, other than program-flow instructions, are performed as register operations in conjunction with seven addressing modes for source operand and four addressing modes for destination operand.

The CPU is integrated with 16 registers that provide reduced instruction execution time. The register-to-register operation execution time is one cycle of the CPU clock.

Four of the registers, R0 to R3, are dedicated as program counter, stack pointer, status register, and constant generator, respectively. The remaining registers are general-purpose registers.

Peripherals are connected to the CPU using data, address, and control buses, and can be handled with all instructions.

The instruction set consists of the original 51 instructions with three formats and seven address modes and additional instructions for the expanded address range. Each instruction can operate on word and byte data.

| | |
|--------------------------|-----------|
| Program Counter | PC/R0 |
| Stack Pointer | SP/R1 |
| Status Register | SR/CG1/R2 |
| Constant Generator | CG2/R3 |
| General-Purpose Register | R4 |
| General-Purpose Register | R5 |
| General-Purpose Register | R6 |
| General-Purpose Register | R7 |
| General-Purpose Register | R8 |
| General-Purpose Register | R9 |
| General-Purpose Register | R10 |
| General-Purpose Register | R11 |
| General-Purpose Register | R12 |
| General-Purpose Register | R13 |
| General-Purpose Register | R14 |
| General-Purpose Register | R15 |

Operating Modes

The MSP430 has one active mode and six software selectable low-power modes of operation. An interrupt event can wake up the device from any of the low-power modes, service the request, and restore back to the low-power mode on return from the interrupt program.

The following seven operating modes can be configured by software:

- Active mode (AM)
 - All clocks are active
- Low-power mode 0 (LPM0)
 - CPU is disabled
 - ACLK and SMCLK remain active, MCLK is disabled
 - FLL loop control remains active
- Low-power mode 1 (LPM1)
 - CPU is disabled
 - FLL loop control is disabled
 - ACLK and SMCLK remain active, MCLK is disabled
- Low-power mode 2 (LPM2)
 - CPU is disabled
 - MCLK and FLL loop control and DCOCLK are disabled
 - DCO's dc-generator remains enabled
 - ACLK remains active
- Low-power mode 3 (LPM3)
 - CPU is disabled
 - MCLK, FLL loop control, and DCOCLK are disabled
 - DCO's dc generator is disabled
 - ACLK remains active
- Low-power mode 4 (LPM4)
 - CPU is disabled
 - ACLK is disabled
 - MCLK, FLL loop control, and DCOCLK are disabled
 - DCO's dc generator is disabled
 - Crystal oscillator is stopped
 - Complete data retention
- Low-power mode 4.5 (LPM4.5)
 - Internal regulator disabled
 - No data retention
 - Wakeup from $\overline{\text{RST}}/\text{NMI}$, P1, and P2

Interrupt Vector Addresses

The interrupt vectors and the power-up start address are located in the address range 0FFFFh to 0FF80h. The vector contains the 16-bit address of the appropriate interrupt-handler instruction sequence.

Table 2. Interrupt Sources, Flags, and Vectors

| INTERRUPT SOURCE | INTERRUPT FLAG | SYSTEM INTERRUPT | WORD ADDRESS | PRIORITY |
|--|---|------------------|--------------|-------------|
| System Reset Power-Up External Reset Watchdog Timeout, Password Violation Flash Memory Password Violation PMM Password Violation | WDTIFG, KEYV (SYSRSTIV) ^{(1) (2)} | Reset | 0FFFEh | 63, highest |
| System NMI PMM Vacant Memory Access JTAG Mailbox | SVMLIFG, SVMHIFG, DLYLIFG, DLYHIFG, VLRLIFG, VLRHIFG, VMAIFG, JMBNIFG, JMBOUTIFG (SYSSNIV) ⁽¹⁾ | (Non)maskable | 0FFFCCh | 62 |
| User NMI NMI Oscillator Fault Flash Memory Access Violation | NMIIFG, OFIFG, ACCVIFG, BUSIFG (SYSUNIV) ^{(1) (2)} | (Non)maskable | 0FFFAh | 61 |
| Comp_B | Comparator B interrupt flags (CBIV) ^{(1) (3)} | Maskable | 0FFF8h | 60 |
| TB0 | TB0CCR0 CCIFG0 ⁽³⁾ | Maskable | 0FFF6h | 59 |
| TB0 | TB0CCR1 CCIFG1 to TB0CCR6 CCIFG6, TB0IFG (TB0IV) ^{(1) (3)} | Maskable | 0FFF4h | 58 |
| Watchdog Timer_A Interval Timer Mode | WDTIFG | Maskable | 0FFF2h | 57 |
| USCI_A0 Receive or Transmit | UCA0RXIFG, UCA0TXIFG (UCA0IV) ^{(1) (3)} | Maskable | 0FFF0h | 56 |
| USCI_B0 Receive or Transmit | UCB0RXIFG, UCB0TXIFG (UCB0IV) ^{(1) (3)} | Maskable | 0FFEEh | 55 |
| ADC12_A | ADC12IFG0 to ADC12IFG15 (ADC12IV) ^{(1) (3) (4)} | Maskable | 0FFECCh | 54 |
| TA0 | TA0CCR0 CCIFG0 ⁽³⁾ | Maskable | 0FFEAh | 53 |
| TA0 | TA0CCR1 CCIFG1 to TA0CCR4 CCIFG4, TA0IFG (TA0IV) ^{(1) (3)} | Maskable | 0FFE8h | 52 |
| LDO-PWR | LDOOFFIFG, LDOONIFG, LDOOVLIFG | Maskable | 0FFE6h | 51 |
| DMA | DMA0IFG, DMA1IFG, DMA2IFG (DMAIV) ^{(1) (3)} | Maskable | 0FFE4h | 50 |
| TA1 | TA1CCR0 CCIFG0 ⁽³⁾ | Maskable | 0FFE2h | 49 |
| TA1 | TA1CCR1 CCIFG1 to TA1CCR2 CCIFG2, TA1IFG (TA1IV) ^{(1) (3)} | Maskable | 0FFE0h | 48 |
| I/O Port P1 | P1IFG.0 to P1IFG.7 (P1IV) ^{(1) (3)} | Maskable | 0FFDEh | 47 |
| USCI_A1 Receive or Transmit | UCA1RXIFG, UCA1TXIFG (UCA1IV) ^{(1) (3)} | Maskable | 0FFDCh | 46 |
| USCI_B1 Receive or Transmit | UCB1RXIFG, UCB1TXIFG (UCB1IV) ^{(1) (3)} | Maskable | 0FFDAh | 45 |
| TA2 | TA2CCR0 CCIFG0 ⁽³⁾ | Maskable | 0FFD8h | 44 |
| TA2 | TA2CCR1 CCIFG1 to TA2CCR2 CCIFG2, TA2IFG (TA2IV) ^{(1) (3)} | Maskable | 0FFD6h | 43 |
| I/O Port P2 | P2IFG.0 to P2IFG.7 (P2IV) ^{(1) (3)} | Maskable | 0FFD4h | 42 |
| RTC_A | RTCRDYIFG, RTCTEVIFG, RTCAIFG, RT0PSIFG, RT1PSIFG (RTCIV) ^{(1) (3)} | Maskable | 0FFD2h | 41 |

(1) Multiple source flags

(2) A reset is generated if the CPU tries to fetch instructions from within peripheral space or vacant memory space.

(Non)maskable: the individual interrupt-enable bit can disable an interrupt event, but the general-interrupt enable cannot disable it.

(3) Interrupt flags are located in the module.

(4) Only on devices with ADC, otherwise reserved.

Table 2. Interrupt Sources, Flags, and Vectors (continued)

| INTERRUPT SOURCE | INTERRUPT FLAG | SYSTEM INTERRUPT | WORD ADDRESS | PRIORITY |
|------------------|-------------------------|------------------|--------------|-----------|
| Reserved | Reserved ⁽⁵⁾ | | 0FFD0h | 40 |
| | | | ⋮ | ⋮ |
| | | | 0FF80h | 0, lowest |

(5) Reserved interrupt vectors at addresses are not used in this device and can be used for regular program code if necessary. To maintain compatibility with other devices, it is recommended to reserve these locations.

Memory Organization

Table 3. Memory Organization⁽¹⁾

| | | MSP430F5328 |
|--|------------|---------------------------|
| Memory (flash) Main: interrupt vector | Total Size | 128 KB 00FFFFh–00FF80h |
| Main: code memory | Bank D | 32 KB 0243FFh–01C400h |
| | Bank C | 32 KB 01C3FFh–014400h |
| | Bank B | 32 KB 0143FFh–00C400h |
| | Bank A | 32 KB 00C3FFh–004400h |
| RAM | Sector 3 | 2 KB 0043FFh–003C00h |
| | Sector 2 | 2 KB 003BFFh–003400h |
| | Sector 1 | 2 KB 0033FFh–002C00h |
| | Sector 0 | 2 KB 002BFFh–002400h |
| | Sector 7 | 2 KB 0023FFh–001C00h |
| Information memory (flash) | Info A | 128 B 0019FFh–001980h |
| | Info B | 128 B 00197Fh–001900h |
| | Info C | 128 B 0018FFh–001880h |
| | Info D | 128 B 00187Fh–001800h |
| Bootstrap loader (BSL) memory (flash) | BSL 3 | 512 B 0017FFh–001600h |
| | BSL 2 | 512 B 0015FFh–001400h |
| | BSL 1 | 512 B 0013FFh–001200h |
| | BSL 0 | 512 B 0011FFh–001000h |
| Peripherals | Size | 4 KB 000FFFh–0h |

(1) N/A = Not available.

Bootstrap Loader (BSL)

The BSL enables users to program the flash memory or RAM using a UART serial interface. Access to the device memory via the BSL is protected by an user-defined password. Usage of the BSL requires four pins as shown in [Table 4](#). BSL entry requires a specific entry sequence on the $\overline{\text{RST}}/\text{NMI}/\text{SBWTDIO}$ and $\text{TEST}/\text{SBWTCK}$ pins. For complete description of the features of the BSL and its implementation, see *MSP430 Programming Via the Bootstrap Loader (SLAU319)*.

Table 4. BSL Pin Requirements and Functions

| DEVICE SIGNAL | BSL FUNCTION |
|---|-----------------------|
| $\overline{\text{RST}}/\text{NMI}/\text{SBWTDIO}$ | Entry sequence signal |
| $\text{TEST}/\text{SBWTCK}$ | Entry sequence signal |
| P1.1 | Data transmit |
| P1.2 | Data receive |
| VCC | Power supply |
| VSS | Ground supply |

JTAG Operation

JTAG Standard Interface

The MSP430 family supports the standard JTAG interface which requires four signals for sending and receiving data. The JTAG signals are shared with general-purpose I/O. The $\text{TEST}/\text{SBWTCK}$ pin is used to enable the JTAG signals. In addition to these signals, the $\overline{\text{RST}}/\text{NMI}/\text{SBWTDIO}$ is required to interface with MSP430 development tools and device programmers. The JTAG pin requirements are shown in [Table 5](#). For further details on interfacing to development tools and device programmers, see the *MSP430 Hardware Tools User's Guide (SLAU278)*. For complete description of the features of the JTAG interface and its implementation, see *MSP430 Programming Via the JTAG Interface (SLAU320)*.

Table 5. JTAG Pin Requirements and Functions

| DEVICE SIGNAL | DIRECTION | FUNCTION |
|---|-----------|-----------------------------|
| PJ.3/TCK | IN | JTAG clock input |
| PJ.2/TMS | IN | JTAG state control |
| PJ.1/TDI/TCLK | IN | JTAG data input, TCLK input |
| PJ.0/TDO | OUT | JTAG data output |
| $\text{TEST}/\text{SBWTCK}$ | IN | Enable JTAG pins |
| $\overline{\text{RST}}/\text{NMI}/\text{SBWTDIO}$ | IN | External reset |
| VCC | | Power supply |
| VSS | | Ground supply |

Spy-Bi-Wire Interface

In addition to the standard JTAG interface, the MSP430 family supports the two wire Spy-Bi-Wire interface. Spy-Bi-Wire can be used to interface with MSP430 development tools and device programmers. The Spy-Bi-Wire interface pin requirements are shown in [Table 6](#). For further details on interfacing to development tools and device programmers, see the *MSP430 Hardware Tools User's Guide (SLAU278)*. For complete description of the features of the JTAG interface and its implementation, see *MSP430 Programming Via the JTAG Interface (SLAU320)*.

Table 6. Spy-Bi-Wire Pin Requirements and Functions

| DEVICE SIGNAL | DIRECTION | FUNCTION |
|---|-----------|-------------------------------|
| $\text{TEST}/\text{SBWTCK}$ | IN | Spy-Bi-Wire clock input |
| $\overline{\text{RST}}/\text{NMI}/\text{SBWTDIO}$ | IN, OUT | Spy-Bi-Wire data input/output |
| VCC | | Power supply |
| VSS | | Ground supply |

Flash Memory ([Link to User's Guide](#))

The flash memory can be programmed via the JTAG port, Spy-Bi-Wire (SBW), the BSL, or in-system by the CPU. The CPU can perform single-byte, single-word, and long-word writes to the flash memory. Features of the flash memory include:

- Flash memory has n segments of main memory and four segments of information memory (A to D) of 128 bytes each. Each segment in main memory is 512 bytes in size.
- Segments 0 to n may be erased in one step, or each segment may be individually erased.
- Segments A to D can be erased individually. Segments A to D are also called *information memory*.
- Segment A can be locked separately.

RAM Memory ([Link to User's Guide](#))

The RAM memory is made up of n sectors. Each sector can be completely powered down to save leakage, however all data is lost. Features of the RAM memory include:

- RAM memory has n sectors. The size of a sector can be found in the Memory Organization section.
- Each sector 0 to n can be complete disabled, however data retention is lost.
- Each sector 0 to n automatically enters low power retention mode when possible.

Peripherals

Peripherals are connected to the CPU through data, address, and control buses and can be handled using all instructions. For complete module descriptions, see the *MSP430x5xx and MSP430x6xx Family User's Guide (SLAU208)*.

Digital I/O ([Link to User's Guide](#))

There are up to eight 8-bit I/O ports implemented: For 80-pin PN options, P1, P2, P3, P4, P5, P6, and P7 are complete, and P8 is reduced to 3-bit I/O. For 80-pin ZQE and 64-pin RGC options, P3 and P5 are reduced to 5-bit I/O and 6-bit I/O, respectively, and P7 and P8 are completely removed. Port PJ contains four individual I/O ports, common to all devices.

- All individual I/O bits are independently programmable.
- Any combination of input, output, and interrupt conditions is possible.
- Pullup or pulldown on all ports is programmable.
- Drive strength on all ports is programmable.
- Edge-selectable interrupt and LPM4.5 wakeup input capability is available for all bits of ports P1 and P2.
- Read/write access to port-control registers is supported by all instructions.
- Ports can be accessed byte-wise (P1 through P8) or word-wise in pairs (PA through PD).

Port Mapping Controller ([Link to User's Guide](#))

The port mapping controller allows the flexible and reconfigurable mapping of digital functions to port P4.

Table 7. Port Mapping, Mnemonics and Functions

| VALUE | PxMAPy MNEMONIC | INPUT PIN FUNCTION | OUTPUT PIN FUNCTION |
|--------------------------|-----------------|---|------------------------------|
| 0 | PM_NONE | None | DVSS |
| 1 | PM_CBOUT0 | - | Comparator_B output |
| | PM_TB0CLK | TB0 clock input | |
| 2 | PM_ADC12CLK | - | ADC12CLK |
| | PM_DMAE0 | DMAE0 input | |
| 3 | PM_SVMOUT | - | SVM output |
| | PM_TB0OUTH | TB0 high-impedance input TB0OUTH | |
| 4 | PM_TB0CCR0A | TB0 CCR0 capture input CCI0A | TB0 CCR0 compare output Out0 |
| 5 | PM_TB0CCR1A | TB0 CCR1 capture input CCI1A | TB0 CCR1 compare output Out1 |
| 6 | PM_TB0CCR2A | TB0 CCR2 capture input CCI2A | TB0 CCR2 compare output Out2 |
| 7 | PM_TB0CCR3A | TB0 CCR3 capture input CCI3A | TB0 CCR3 compare output Out3 |
| 8 | PM_TB0CCR4A | TB0 CCR4 capture input CCI4A | TB0 CCR4 compare output Out4 |
| 9 | PM_TB0CCR5A | TB0 CCR5 capture input CCI5A | TB0 CCR5 compare output Out5 |
| 10 | PM_TB0CCR6A | TB0 CCR6 capture input CCI6A | TB0 CCR6 compare output Out6 |
| 11 | PM_UCA1RXD | USCI_A1 UART RXD (Direction controlled by USCI - input) | |
| | PM_UCA1SOMI | USCI_A1 SPI slave out master in (direction controlled by USCI) | |
| 12 | PM_UCA1TXD | USCI_A1 UART TXD (Direction controlled by USCI - output) | |
| | PM_UCA1SIMO | USCI_A1 SPI slave in master out (direction controlled by USCI) | |
| 13 | PM_UCA1CLK | USCI_A1 clock input/output (direction controlled by USCI) | |
| | PM_UCB1STE | USCI_B1 SPI slave transmit enable (direction controlled by USCI) | |
| 14 | PM_UCB1SOMI | USCI_B1 SPI slave out master in (direction controlled by USCI) | |
| | PM_UCB1SCL | USCI_B1 I2C clock (open drain and direction controlled by USCI) | |
| 15 | PM_UCB1SIMO | USCI_B1 SPI slave in master out (direction controlled by USCI) | |
| | PM_UCB1SDA | USCI_B1 I2C data (open drain and direction controlled by USCI) | |
| 16 | PM_UCB1CLK | USCI_B1 clock input/output (direction controlled by USCI) | |
| | PM_UCA1STE | USCI_A1 SPI slave transmit enable (direction controlled by USCI) | |
| 17 | PM_CBOUT1 | None | Comparator_B output |
| 18 | PM_MCLK | None | MCLK |
| 19 - 30 | Reserved | None | DVSS |
| 31 (0FFh) ⁽¹⁾ | PM_ANALOG | Disables the output driver as well as the input Schmitt-trigger to prevent parasitic cross currents when applying analog signals. | |

(1) The value of the PM_ANALOG mnemonic is set to 0FFh. The port mapping registers are only 5 bits wide and the upper bits are ignored resulting in a read out value of 31.

Table 8. Default Mapping

| PIN | PxMAPy MNEMONIC | INPUT PIN FUNCTION | OUTPUT PIN FUNCTION |
|-------------|------------------------|---|---------------------|
| P4.0/P4MAP0 | PM_UCB1STE/PM_UCA1CLK | USCI_B1 SPI slave transmit enable (direction controlled by USCI) USCI_A1 clock input/output (direction controlled by USCI) | |
| P4.1/P4MAP1 | PM_UCB1SIMO/PM_UCB1SDA | USCI_B1 SPI slave in master out (direction controlled by USCI) USCI_B1 I2C data (open drain and direction controlled by USCI) | |
| P4.2/P4MAP2 | PM_UCB1SOMI/PM_UCB1SCL | USCI_B1 SPI slave out master in (direction controlled by USCI) USCI_B1 I2C clock (open drain and direction controlled by USCI) | |
| P4.3/P4MAP3 | PM_UCB1CLK/PM_UCA1STE | USCI_A1 SPI slave transmit enable (direction controlled by USCI) USCI_B1 clock input/output (direction controlled by USCI) | |
| P4.4/P4MAP4 | PM_UCA1TXD/PM_UCA1SIMO | USCI_A1 UART TXD (Direction controlled by USCI - output) USCI_A1 SPI slave in master out (direction controlled by USCI) | |
| P4.5/P4MAP5 | PM_UCA1RXD/PM_UCA1SOMI | USCI_A1 UART RXD (Direction controlled by USCI - input) USCI_A1 SPI slave out master in (direction controlled by USCI) | |
| P4.6/P4MAP6 | PM_NONE | None | DVSS |
| P4.7/P4MAP7 | PM_NONE | None | DVSS |

Oscillator and System Clock ([Link to User's Guide](#))

The clock system in the MSP430F532x family of devices is supported by the Unified Clock System (UCS) module that includes support for a 32-kHz watch crystal oscillator (XT1 LF mode only; XT1 HF mode is not supported), an internal very-low-power low-frequency oscillator (VLO), an internal trimmed low-frequency oscillator (REFO), an integrated internal digitally-controlled oscillator (DCO), and a high-frequency crystal oscillator XT2. The UCS module is designed to meet the requirements of both low system cost and low power consumption. The UCS module features digital frequency-locked loop (FLL) hardware that, in conjunction with a digital modulator, stabilizes the DCO frequency to a programmable multiple of the selected FLL reference frequency. The internal DCO provides a fast turn-on clock source and stabilizes in 3.5 μ s (typical). The UCS module provides the following clock signals:

- Auxiliary clock (ACLK), sourced from a 32-kHz watch crystal (XT1), a high-frequency crystal (XT2), the internal low-frequency oscillator (VLO), the trimmed low-frequency oscillator (REFO), or the internal DCO.
- Main clock (MCLK), the system clock used by the CPU. MCLK can be sourced by same sources made available to ACLK.
- Sub-Main clock (SMCLK), the subsystem clock used by the peripheral modules. SMCLK can be sourced by same sources made available to ACLK.
- ACLK/n, the buffered output of ACLK, ACLK/2, ACLK/4, ACLK/8, ACLK/16, ACLK/32.

Power Management Module (PMM) ([Link to User's Guide](#))

The PMM includes an integrated voltage regulator that supplies the core voltage to the device and contains programmable output levels to provide for power optimization. The PMM also includes supply voltage supervisor (SVS) and supply voltage monitoring (SVM) circuitry, as well as brownout protection. The brownout circuit is implemented to provide the proper internal reset signal to the device during power-on and power-off. The SVS/SVM circuitry detects if the supply voltage drops below a user-selectable level and supports both supply voltage supervision (the device is automatically reset) and supply voltage monitoring (the device is not automatically reset). SVS and SVM circuitry are available on the primary supply and core supply.

Hardware Multiplier (MPY) ([Link to User's Guide](#))

The multiplication operation is supported by a dedicated peripheral module. The module performs operations with 32-bit, 24-bit, 16-bit, and 8-bit operands. The module is capable of supporting signed and unsigned multiplication as well as signed and unsigned multiply and accumulate operations.

Real-Time Clock (RTC_A) ([Link to User's Guide](#))

The RTC_A module can be used as a general-purpose 32-bit counter (counter mode) or as an integrated real-time clock (RTC) (calendar mode). In counter mode, the RTC_A also includes two independent 8-bit timers that can be cascaded to form a 16-bit timer/counter. Both timers can be read and written by software. Calendar mode integrates an internal calendar which compensates for months with less than 31 days and includes leap year correction. The RTC_A also supports flexible alarm functions and offset-calibration hardware.

Watchdog Timer (WDT_A) ([Link to User's Guide](#))

The primary function of the watchdog timer (WDT_A) module is to perform a controlled system restart after a software problem occurs. If the selected time interval expires, a system reset is generated. If the watchdog function is not needed in an application, the module can be configured as an interval timer and can generate interrupts at selected time intervals.

System Module (SYS) ([Link to User's Guide](#))

The SYS module handles many of the system functions within the device. These include power on reset and power up clear handling, NMI source selection and management, reset interrupt vector generators, boot strap loader entry mechanisms, as well as, configuration management (device descriptors). It also includes a data exchange mechanism via JTAG called a JTAG mailbox that can be used in the application.

Table 9. System Module Interrupt Vector Registers

| INTERRUPT VECTOR REGISTER | ADDRESS | INTERRUPT EVENT | VALUE | PRIORITY |
|-------------------------------|------------|-------------------------------------|------------|----------|
| SYSRSTIV, System Reset | 019Eh | No interrupt pending | 00h | |
| | | Brownout (BOR) | 02h | Highest |
| | | $\overline{\text{RST}}$ /NMI (POR) | 04h | |
| | | PMMSWBOR (BOR) | 06h | |
| | | Wakeup from LPMx.5 | 08h | |
| | | Security violation (BOR) | 0Ah | |
| | | SVSL (POR) | 0Ch | |
| | | SVSH (POR) | 0Eh | |
| | | SVML_OVP (POR) | 10h | |
| | | SVMH_OVP (POR) | 12h | |
| | | PMMSWPOR (POR) | 14h | |
| | | WDT timeout (PUC) | 16h | |
| | | WDT password violation (PUC) | 18h | |
| | | KEYV flash password violation (PUC) | 1Ah | |
| | | Reserved | 1Ch | |
| | | Peripheral area fetch (PUC) | 1Eh | |
| | | PMM password violation (PUC) | 20h | |
| Reserved | 22h to 3Eh | Lowest | | |
| SYSSNIV, System NMI | 019Ch | No interrupt pending | 00h | |
| | | SVMLIFG | 02h | Highest |
| | | SVMHIFG | 04h | |
| | | SVSMLDLYIFG | 06h | |
| | | SVSMHDLYIFG | 08h | |
| | | VMAIFG | 0Ah | |
| | | JMBINIFG | 0Ch | |
| | | JMBOUTIFG | 0Eh | |
| | | SVMLVLRIFG | 10h | |
| | | SVMHVLRFIFG | 12h | |
| | | Reserved | 14h to 1Eh | Lowest |
| SYSUNIV, User NMI | 019Ah | No interrupt pending | 00h | |
| | | NMIFG | 02h | Highest |
| | | OFIFG | 04h | |
| | | ACCVIFG | 06h | |
| | | Reserved | 08h | |
| | | Reserved | 0Ah to 1Eh | Lowest |

DMA Controller ([Link to User's Guide](#))

The DMA controller allows movement of data from one memory address to another without CPU intervention. For example, the DMA controller can be used to move data from the ADC12_A conversion memory to RAM. Using the DMA controller can increase the throughput of peripheral modules. The DMA controller reduces system power consumption by allowing the CPU to remain in sleep mode, without having to awaken to move data to or from a peripheral.

Table 10. DMA Trigger Assignments⁽¹⁾

| TRIGGER | CHANNEL | | |
|---------|---------------|---------------|---------------|
| | 0 | 1 | 2 |
| 0 | DMAREQ | DMAREQ | DMAREQ |
| 1 | TA0CCR0 CCIFG | TA0CCR0 CCIFG | TA0CCR0 CCIFG |
| 2 | TA0CCR2 CCIFG | TA0CCR2 CCIFG | TA0CCR2 CCIFG |
| 3 | TA1CCR0 CCIFG | TA1CCR0 CCIFG | TA1CCR0 CCIFG |
| 4 | TA1CCR2 CCIFG | TA1CCR2 CCIFG | TA1CCR2 CCIFG |
| 5 | TA2CCR0 CCIFG | TA2CCR0 CCIFG | TA2CCR0 CCIFG |
| 6 | TA2CCR2 CCIFG | TA2CCR2 CCIFG | TA2CCR2 CCIFG |
| 7 | TB0CCR0 CCIFG | TB0CCR0 CCIFG | TB0CCR0 CCIFG |
| 8 | TB0CCR2 CCIFG | TB0CCR2 CCIFG | TB0CCR2 CCIFG |
| 9 | Reserved | Reserved | Reserved |
| 10 | Reserved | Reserved | Reserved |
| 11 | Reserved | Reserved | Reserved |
| 12 | Reserved | Reserved | Reserved |
| 13 | Reserved | Reserved | Reserved |
| 14 | Reserved | Reserved | Reserved |
| 15 | Reserved | Reserved | Reserved |
| 16 | UCA0RXIFG | UCA0RXIFG | UCA0RXIFG |
| 17 | UCA0TXIFG | UCA0TXIFG | UCA0TXIFG |
| 18 | UCB0RXIFG | UCB0RXIFG | UCB0RXIFG |
| 19 | UCB0TXIFG | UCB0TXIFG | UCB0TXIFG |
| 20 | UCA1RXIFG | UCA1RXIFG | UCA1RXIFG |
| 21 | UCA1TXIFG | UCA1TXIFG | UCA1TXIFG |
| 22 | UCB1RXIFG | UCB1RXIFG | UCB1RXIFG |
| 23 | UCB1TXIFG | UCB1TXIFG | UCB1TXIFG |
| 24 | ADC12IFGx | ADC12IFGx | ADC12IFGx |
| 25 | Reserved | Reserved | Reserved |
| 26 | Reserved | Reserved | Reserved |
| 27 | Reserved | Reserved | Reserved |
| 28 | Reserved | Reserved | Reserved |
| 29 | MPY ready | MPY ready | MPY ready |
| 30 | DMA2IFG | DMA0IFG | DMA1IFG |
| 31 | DMAE0 | DMAE0 | DMAE0 |

(1) If a reserved trigger source is selected, no trigger is generated.

Universal Serial Communication Interface (USCI) (Links to User's Guide: [UART Mode](#), [SPI Mode](#), [I2C Mode](#))

The USCI modules are used for serial data communication. The USCI module supports synchronous communication protocols such as SPI (3 or 4 pin) and I²C, and asynchronous communication protocols such as UART, enhanced UART with automatic baudrate detection, and IrDA. Each USCI module contains two portions, A and B.

The USCI_An module provides support for SPI (3 pin or 4 pin), UART, enhanced UART, or IrDA.

The USCI_Bn module provides support for SPI (3 pin or 4 pin) or I²C.

The MSP430F532x series includes two complete USCI modules (n = 0, 1).

TA0 (Link to User's Guide)

TA0 is a 16-bit timer/counter (Timer_A type) with five capture/compare registers. It can support multiple capture/compares, PWM outputs, and interval timing. It also has extensive interrupt capabilities. Interrupts may be generated from the counter on overflow conditions and from each of the capture/compare registers.

Table 11. TA0 Signal Connections

| INPUT PIN NUMBER | DEVICE INPUT SIGNAL | MODULE INPUT SIGNAL | MODULE BLOCK | MODULE OUTPUT SIGNAL | DEVICE OUTPUT SIGNAL | OUTPUT PIN NUMBER |
|------------------|------------------------------|---------------------------|--------------|----------------------|----------------------|-------------------|
| RGC | | | | | | RGC |
| 18, H2-P1.0 | TA0CLK | TACLK | Timer | NA | NA | |
| | ACLK (internal) | ACLK | | | | |
| | SMCLK (internal) | SMCLK | | | | |
| 18, H2-P1.0 | TA0CLK | $\overline{\text{TACLK}}$ | | | | |
| 19, H3-P1.1 | TA0.0 | CCI0A | CCR0 | TA0 | TA0.0 | 19, H3-P1.1 |
| | DV _{SS} | CCI0B | | | | |
| | DV _{SS} | GND | | | | |
| | DV _{CC} | V _{CC} | | | | |
| 20, J3-P1.2 | TA0.1 | CCI1A | CCR1 | TA1 | TA0.1 | 20, J3-P1.2 |
| | CBOU _T (internal) | CCI1B | | | | |
| | DV _{SS} | GND | | | | |
| | DV _{CC} | V _{CC} | | | | |
| 21, G4-P1.3 | TA0.2 | CCI2A | CCR2 | TA2 | TA0.2 | 21, G4-P1.3 |
| | ACLK (internal) | CCI2B | | | | |
| | DV _{SS} | GND | | | | |
| | DV _{CC} | V _{CC} | | | | |
| 22, H4-P1.4 | TA0.3 | CCI3A | CCR3 | TA3 | TA0.3 | 22, H4-P1.4 |
| | DV _{SS} | CCI3B | | | | |
| | DV _{SS} | GND | | | | |
| | DV _{CC} | V _{CC} | | | | |
| 23, J4-P1.5 | TA0.4 | CCI4A | CCR4 | TA4 | TA0.4 | 23, J4-P1.5 |
| | DV _{SS} | CCI4B | | | | |
| | DV _{SS} | GND | | | | |
| | DV _{CC} | V _{CC} | | | | |

TA1 (Link to User's Guide)

TA1 is a 16-bit timer/counter (Timer_A type) with three capture/compare registers. It can support multiple capture/compares, PWM outputs, and interval timing. It also has extensive interrupt capabilities. Interrupts may be generated from the counter on overflow conditions and from each of the capture/compare registers.

Table 12. TA1 Signal Connections

| INPUT PIN NUMBER | DEVICE INPUT SIGNAL | MODULE INPUT SIGNAL | MODULE BLOCK | MODULE OUTPUT SIGNAL | DEVICE OUTPUT SIGNAL | OUTPUT PIN NUMBER |
|------------------|---------------------|---------------------------|--------------|----------------------|----------------------|-------------------|
| RGC | | | | | | RGC |
| 24, G5-P1.6 | TA1CLK | TACLK | Timer | NA | NA | |
| | ACLK (internal) | ACLK | | | | |
| | SMCLK (internal) | SMCLK | | | | |
| 24, G5-P1.6 | TA1CLK | $\overline{\text{TACLK}}$ | | | | |
| 25, H5-P1.7 | TA1.0 | CC10A | CCR0 | TA0 | TA1.0 | 25, H5-P1.7 |
| | DV _{SS} | CC10B | | | | |
| | DV _{SS} | GND | | | | |
| | DV _{CC} | V _{CC} | | | | |
| 26, J5-P2.0 | TA1.1 | CC11A | CCR1 | TA1 | TA1.1 | 26, J5-P2.0 |
| | CBOUT (internal) | CC11B | | | | |
| | DV _{SS} | GND | | | | |
| | DV _{CC} | V _{CC} | | | | |
| 27, G6-P2.1 | TA1.2 | CC12A | CCR2 | TA2 | TA1.2 | 27, G6-P2.1 |
| | ACLK (internal) | CC12B | | | | |
| | DV _{SS} | GND | | | | |
| | DV _{CC} | V _{CC} | | | | |

TA2 (Link to User's Guide)

TA2 is a 16-bit timer/counter (Timer_A type) with three capture/compare registers. It can support multiple capture/compares, PWM outputs, and interval timing. It also has extensive interrupt capabilities. Interrupts may be generated from the counter on overflow conditions and from each of the capture/compare registers.

Table 13. TA2 Signal Connections

| INPUT PIN NUMBER | DEVICE INPUT SIGNAL | MODULE INPUT SIGNAL | MODULE BLOCK | MODULE OUTPUT SIGNAL | DEVICE OUTPUT SIGNAL | OUTPUT PIN NUMBER |
|------------------|---------------------|---------------------------|--------------|----------------------|----------------------|-------------------|
| RGC | | | | | | RGC |
| 28, J6-P2.2 | TA2CLK | TACLK | Timer | NA | NA | |
| | ACLK (internal) | ACLK | | | | |
| | SMCLK (internal) | SMCLK | | | | |
| 28, J6-P2.2 | TA2CLK | $\overline{\text{TACLK}}$ | | | | |
| 29, H6-P2.3 | TA2.0 | CC10A | CCR0 | TA0 | TA2.0 | 29, H6-P2.3 |
| | DV _{SS} | CC10B | | | | |
| | DV _{SS} | GND | | | | |
| | DV _{CC} | V _{CC} | | | | |
| 30, J7-P2.4 | TA2.1 | CC11A | CCR1 | TA1 | TA2.1 | 30, J7-P2.4 |
| | CBOUT (internal) | CC11B | | | | |
| | DV _{SS} | GND | | | | |
| | DV _{CC} | V _{CC} | | | | |
| 31, J8-P2.5 | TA2.2 | CC12A | CCR2 | TA2 | TA2.2 | 31, J8-P2.5 |
| | ACLK (internal) | CC12B | | | | |
| | DV _{SS} | GND | | | | |
| | DV _{CC} | V _{CC} | | | | |

TB0 (Link to User's Guide)

TB0 is a 16-bit timer/counter (Timer_B type) with seven capture/compare registers. It can support multiple capture/compares, PWM outputs, and interval timing. It also has extensive interrupt capabilities. Interrupts may be generated from the counter on overflow conditions and from each of the capture/compare registers.

Table 14. TB0 Signal Connections

| INPUT PIN NUMBER | DEVICE INPUT SIGNAL | MODULE INPUT SIGNAL | MODULE BLOCK | MODULE OUTPUT SIGNAL | DEVICE OUTPUT SIGNAL | OUTPUT PIN NUMBER | |
|--------------------|---------------------|---------------------------|--------------|----------------------|----------------------|-------------------------------------|--|
| RGC ⁽¹⁾ | | | | | | RGC ⁽¹⁾ | |
| | TB0CLK | TBCLK | Timer | NA | NA | | |
| | ACLK (internal) | ACLK | | | | | |
| | SMCLK (internal) | SMCLK | | | | | |
| | TB0CLK | $\overline{\text{TBCLK}}$ | | | | | |
| | TB0.0 | CCI0A | CCR0 | TB0 | TB0.0 | ADC12 (internal) ADC12SHSx = {2} | |
| | TB0.0 | CCI0B | | | | | |
| | DV _{SS} | GND | | | | | |
| | DV _{CC} | V _{CC} | | | | | |
| | TB0.1 | CCI1A | CCR1 | TB1 | TB0.1 | ADC12 (internal) ADC12SHSx = {3} | |
| | CBOUT (internal) | CCI1B | | | | | |
| | DV _{SS} | GND | | | | | |
| | DV _{CC} | V _{CC} | | | | | |
| | TB0.2 | CCI2A | CCR2 | TB2 | TB0.2 | | |
| | TB0.2 | CCI2B | | | | | |
| | DV _{SS} | GND | | | | | |
| | DV _{CC} | V _{CC} | | | | | |
| | TB0.3 | CCI3A | CCR3 | TB3 | TB0.3 | | |
| | TB0.3 | CCI3B | | | | | |
| | DV _{SS} | GND | | | | | |
| | DV _{CC} | V _{CC} | | | | | |
| | TB0.4 | CCI4A | CCR4 | TB4 | TB0.4 | | |
| | TB0.4 | CCI4B | | | | | |
| | DV _{SS} | GND | | | | | |
| | DV _{CC} | V _{CC} | | | | | |
| | TB0.5 | CCI5A | CCR5 | TB5 | TB0.5 | | |
| | TB0.5 | CCI5B | | | | | |
| | DV _{SS} | GND | | | | | |
| | DV _{CC} | V _{CC} | | | | | |
| | TB0.6 | CCI6A | CCR6 | TB6 | TB0.6 | | |
| | ACLK (internal) | CCI6B | | | | | |
| | DV _{SS} | GND | | | | | |
| | DV _{CC} | V _{CC} | | | | | |

(1) Timer functions are selectable through the port mapping controller.

Comparator_B (Link to User's Guide)

The primary function of the Comparator_B module is to support precision slope analog-to-digital conversions, battery voltage supervision, and monitoring of external analog signals.

ADC12_A (Link to User's Guide)

The ADC12_A module supports fast, 12-bit analog-to-digital conversions. The module implements a 12-bit SAR core, sample select control, reference generator and a 16 word conversion-and-control buffer. The conversion-and-control buffer allows up to 16 independent ADC samples to be converted and stored without any CPU intervention.

CRC16 (Link to User's Guide)

The CRC16 module produces a signature based on a sequence of entered data values and can be used for data checking purposes. The CRC16 module signature is based on the CRC-CCITT standard.

REF Voltage Reference (Link to User's Guide)

The reference module (REF) is responsible for generation of all critical reference voltages that can be used by the various analog peripherals in the device.

Embedded Emulation Module (EEM) (Link to User's Guide)

The Embedded Emulation Module (EEM) supports real-time in-system debugging. The L version of the EEM implemented on all devices has the following features:

- Eight hardware triggers or breakpoints on memory access
- Two hardware trigger or breakpoint on CPU register write access
- Up to ten hardware triggers can be combined to form complex triggers or breakpoints
- Two cycle counters
- Sequencer
- State storage
- Clock control on module level

Peripheral File Map

Table 15. Peripherals

| MODULE NAME | BASE ADDRESS | OFFSET ADDRESS RANGE |
|--|--------------|----------------------|
| Special Functions (see Table 16) | 0100h | 000h-01Fh |
| PMM (see Table 17) | 0120h | 000h-010h |
| Flash Control (see Table 18) | 0140h | 000h-00Fh |
| CRC16 (see Table 19) | 0150h | 000h-007h |
| RAM Control (see Table 20) | 0158h | 000h-001h |
| Watchdog (see Table 21) | 015Ch | 000h-001h |
| UCS (see Table 22) | 0160h | 000h-01Fh |
| SYS (see Table 23) | 0180h | 000h-01Fh |
| Shared Reference (see Table 24) | 01B0h | 000h-001h |
| Port Mapping Control (see Table 25) | 01C0h | 000h-002h |
| Port Mapping Port P4 (see Table 25) | 01E0h | 000h-007h |
| Port P1/P2 (see Table 26) | 0200h | 000h-01Fh |
| Port P3/P4 (see Table 27) | 0220h | 000h-00Bh |
| Port P5/P6 (see Table 28) | 0240h | 000h-00Bh |
| Port P7/P8 (see Table 29) | 0260h | 000h-00Bh |
| Port PJ (see Table 30) | 0320h | 000h-01Fh |
| TA0 (see Table 31) | 0340h | 000h-02Eh |
| TA1 (see Table 32) | 0380h | 000h-02Eh |
| TB0 (see Table 33) | 03C0h | 000h-02Eh |
| TA2 (see Table 34) | 0400h | 000h-02Eh |
| Real-Time Clock (RTC_A) (see Table 35) | 04A0h | 000h-01Bh |
| 32-Bit Hardware Multiplier (see Table 36) | 04C0h | 000h-02Fh |
| DMA General Control (see Table 37) | 0500h | 000h-00Fh |
| DMA Channel 0 (see Table 37) | 0510h | 000h-00Ah |
| DMA Channel 1 (see Table 37) | 0520h | 000h-00Ah |
| DMA Channel 2 (see Table 37) | 0530h | 000h-00Ah |
| USCI_A0 (see Table 38) | 05C0h | 000h-01Fh |
| USCI_B0 (see Table 39) | 05E0h | 000h-01Fh |
| USCI_A1 (see Table 40) | 0600h | 000h-01Fh |
| USCI_B1 (see Table 41) | 0620h | 000h-01Fh |
| ADC12_A (see Table 42) | 0700h | 000h-03Eh |
| Comparator_B (see Table 43) | 08C0h | 000h-00Fh |
| LDO-PWR and Port U configuration (see Table 44) | 0900h | 000h-014h |

Table 16. Special Function Registers (Base Address: 0100h)

| REGISTER DESCRIPTION | REGISTER | OFFSET |
|-----------------------|----------|--------|
| SFR interrupt enable | SFRIE1 | 00h |
| SFR interrupt flag | SFRIFG1 | 02h |
| SFR reset pin control | SFRRPCR | 04h |

Table 17. PMM Registers (Base Address: 0120h)

| REGISTER DESCRIPTION | REGISTER | OFFSET |
|--------------------------|----------|--------|
| PMM Control 0 | PMMCTL0 | 00h |
| PMM control 1 | PMMCTL1 | 02h |
| SVS high side control | SVSMHCTL | 04h |
| SVS low side control | SVSMLCTL | 06h |
| PMM interrupt flags | PMMIFG | 0Ch |
| PMM interrupt enable | PMMIE | 0Eh |
| PMM power mode 5 control | PM5CTL0 | 10h |

Table 18. Flash Control Registers (Base Address: 0140h)

| REGISTER DESCRIPTION | REGISTER | OFFSET |
|----------------------|----------|--------|
| Flash control 1 | FCTL1 | 00h |
| Flash control 3 | FCTL3 | 04h |
| Flash control 4 | FCTL4 | 06h |

Table 19. CRC16 Registers (Base Address: 0150h)

| REGISTER DESCRIPTION | REGISTER | OFFSET |
|-------------------------------|-----------|--------|
| CRC data input | CRC16DI | 00h |
| CRC data input reverse byte | CRCDIRB | 02h |
| CRC initialization and result | CRCINIRES | 04h |
| CRC result reverse byte | CRCRESR | 06h |

Table 20. RAM Control Registers (Base Address: 0158h)

| REGISTER DESCRIPTION | REGISTER | OFFSET |
|----------------------|----------|--------|
| RAM control 0 | RCCTL0 | 00h |

Table 21. Watchdog Registers (Base Address: 015Ch)

| REGISTER DESCRIPTION | REGISTER | OFFSET |
|------------------------|----------|--------|
| Watchdog timer control | WDTCTL | 00h |

Table 22. UCS Registers (Base Address: 0160h)

| REGISTER DESCRIPTION | REGISTER | OFFSET |
|----------------------|----------|--------|
| UCS control 0 | UCSCTL0 | 00h |
| UCS control 1 | UCSCTL1 | 02h |
| UCS control 2 | UCSCTL2 | 04h |
| UCS control 3 | UCSCTL3 | 06h |
| UCS control 4 | UCSCTL4 | 08h |
| UCS control 5 | UCSCTL5 | 0Ah |
| UCS control 6 | UCSCTL6 | 0Ch |
| UCS control 7 | UCSCTL7 | 0Eh |
| UCS control 8 | UCSCTL8 | 10h |

Table 23. SYS Registers (Base Address: 0180h)

| REGISTER DESCRIPTION | REGISTER | OFFSET |
|-------------------------------------|-----------|--------|
| System control | SYSCCTL | 00h |
| Bootstrap loader configuration area | SYSBSLC | 02h |
| JTAG mailbox control | SYSJMBC | 06h |
| JTAG mailbox input 0 | SYSJMBI0 | 08h |
| JTAG mailbox input 1 | SYSJMBI1 | 0Ah |
| JTAG mailbox output 0 | SYSJMBO0 | 0Ch |
| JTAG mailbox output 1 | SYSJMBO1 | 0Eh |
| Bus Error vector generator | SYSBERRIV | 18h |
| User NMI vector generator | SYSUNIV | 1Ah |
| System NMI vector generator | SYSSNIV | 1Ch |
| Reset vector generator | SYSRSTIV | 1Eh |

Table 24. Shared Reference Registers (Base Address: 01B0h)

| REGISTER DESCRIPTION | REGISTER | OFFSET |
|--------------------------|----------|--------|
| Shared reference control | REFCTL | 00h |

**Table 25. Port Mapping Registers
(Base Address of Port Mapping Control: 01C0h, Port P4: 01E0h)**

| REGISTER DESCRIPTION | REGISTER | OFFSET |
|-------------------------------|------------|--------|
| Port mapping key/ID register | P4MAPKEYID | 00h |
| Port mapping control register | P4MAPCTL | 02h |
| Port P4.0 mapping register | P4MAP0 | 00h |
| Port P4.1 mapping register | P4MAP1 | 01h |
| Port P4.2 mapping register | P4MAP2 | 02h |
| Port P4.3 mapping register | P4MAP3 | 03h |
| Port P4.4 mapping register | P4MAP4 | 04h |
| Port P4.5 mapping register | P4MAP5 | 05h |
| Port P4.6 mapping register | P4MAP6 | 06h |
| Port P4.7 mapping register | P4MAP7 | 07h |

Table 26. Port P1/P2 Registers (Base Address: 0200h)

| REGISTER DESCRIPTION | REGISTER | OFFSET |
|--------------------------------|----------|--------|
| Port P1 input | P1IN | 00h |
| Port P1 output | P1OUT | 02h |
| Port P1 direction | P1DIR | 04h |
| Port P1 pullup/pulldown enable | P1REN | 06h |
| Port P1 drive strength | P1DS | 08h |
| Port P1 selection | P1SEL | 0Ah |
| Port P1 interrupt vector word | P1IV | 0Eh |
| Port P1 interrupt edge select | P1IES | 18h |
| Port P1 interrupt enable | P1IE | 1Ah |
| Port P1 interrupt flag | P1IFG | 1Ch |
| Port P2 input | P2IN | 01h |
| Port P2 output | P2OUT | 03h |
| Port P2 direction | P2DIR | 05h |
| Port P2 pullup/pulldown enable | P2REN | 07h |
| Port P2 drive strength | P2DS | 09h |
| Port P2 selection | P2SEL | 0Bh |
| Port P2 interrupt vector word | P2IV | 1Eh |
| Port P2 interrupt edge select | P2IES | 19h |
| Port P2 interrupt enable | P2IE | 1Bh |
| Port P2 interrupt flag | P2IFG | 1Dh |

Table 27. Port P3/P4 Registers (Base Address: 0220h)

| REGISTER DESCRIPTION | REGISTER | OFFSET |
|--------------------------------|----------|--------|
| Port P3 input | P3IN | 00h |
| Port P3 output | P3OUT | 02h |
| Port P3 direction | P3DIR | 04h |
| Port P3 pullup/pulldown enable | P3REN | 06h |
| Port P3 drive strength | P3DS | 08h |
| Port P3 selection | P3SEL | 0Ah |
| Port P4 input | P4IN | 01h |
| Port P4 output | P4OUT | 03h |
| Port P4 direction | P4DIR | 05h |
| Port P4 pullup/pulldown enable | P4REN | 07h |
| Port P4 drive strength | P4DS | 09h |
| Port P4 selection | P4SEL | 0Bh |

Table 28. Port P5/P6 Registers (Base Address: 0240h)

| REGISTER DESCRIPTION | REGISTER | OFFSET |
|--------------------------------|----------|--------|
| Port P5 input | P5IN | 00h |
| Port P5 output | P5OUT | 02h |
| Port P5 direction | P5DIR | 04h |
| Port P5 pullup/pulldown enable | P5REN | 06h |
| Port P5 drive strength | P5DS | 08h |
| Port P5 selection | P5SEL | 0Ah |
| Port P6 input | P6IN | 01h |
| Port P6 output | P6OUT | 03h |
| Port P6 direction | P6DIR | 05h |
| Port P6 pullup/pulldown enable | P6REN | 07h |
| Port P6 drive strength | P6DS | 09h |
| Port P6 selection | P6SEL | 0Bh |

Table 29. Port P7/P8 Registers (Base Address: 0260h)

| REGISTER DESCRIPTION | REGISTER | OFFSET |
|--------------------------------|----------|--------|
| Port P7 input | P7IN | 00h |
| Port P7 output | P7OUT | 02h |
| Port P7 direction | P7DIR | 04h |
| Port P7 pullup/pulldown enable | P7REN | 06h |
| Port P7 drive strength | P7DS | 08h |
| Port P7 selection | P7SEL | 0Ah |
| Port P8 input | P8IN | 01h |
| Port P8 output | P8OUT | 03h |
| Port P8 direction | P8DIR | 05h |
| Port P8 pullup/pulldown enable | P8REN | 07h |
| Port P8 drive strength | P8DS | 09h |
| Port P8 selection | P8SEL | 0Bh |

Table 30. Port J Registers (Base Address: 0320h)

| REGISTER DESCRIPTION | REGISTER | OFFSET |
|--------------------------------|----------|--------|
| Port PJ input | PJIN | 00h |
| Port PJ output | PJOUT | 02h |
| Port PJ direction | PJDIR | 04h |
| Port PJ pullup/pulldown enable | PJREN | 06h |
| Port PJ drive strength | PJDS | 08h |

Table 31. TA0 Registers (Base Address: 0340h)

| REGISTER DESCRIPTION | REGISTER | OFFSET |
|----------------------------|----------|--------|
| TA0 control | TAOCTL | 00h |
| Capture/compare control 0 | TAOCCTL0 | 02h |
| Capture/compare control 1 | TAOCCTL1 | 04h |
| Capture/compare control 2 | TAOCCTL2 | 06h |
| Capture/compare control 3 | TAOCCTL3 | 08h |
| Capture/compare control 4 | TAOCCTL4 | 0Ah |
| TA0 counter register | TAOR | 10h |
| Capture/compare register 0 | TAOCCR0 | 12h |
| Capture/compare register 1 | TAOCCR1 | 14h |
| Capture/compare register 2 | TAOCCR2 | 16h |
| Capture/compare register 3 | TAOCCR3 | 18h |
| Capture/compare register 4 | TAOCCR4 | 1Ah |
| TA0 expansion register 0 | TAOEX0 | 20h |
| TA0 interrupt vector | TAOIV | 2Eh |

Table 32. TA1 Registers (Base Address: 0380h)

| REGISTER DESCRIPTION | REGISTER | OFFSET |
|----------------------------|----------|--------|
| TA1 control | TA1CTL | 00h |
| Capture/compare control 0 | TA1CCTL0 | 02h |
| Capture/compare control 1 | TA1CCTL1 | 04h |
| Capture/compare control 2 | TA1CCTL2 | 06h |
| TA1 counter register | TA1R | 10h |
| Capture/compare register 0 | TA1CCR0 | 12h |
| Capture/compare register 1 | TA1CCR1 | 14h |
| Capture/compare register 2 | TA1CCR2 | 16h |
| TA1 expansion register 0 | TA1EX0 | 20h |
| TA1 interrupt vector | TA1IV | 2Eh |

Table 33. TB0 Registers (Base Address: 03C0h)

| REGISTER DESCRIPTION | REGISTER | OFFSET |
|----------------------------|----------|--------|
| TB0 control | TB0CTL | 00h |
| Capture/compare control 0 | TB0CCTL0 | 02h |
| Capture/compare control 1 | TB0CCTL1 | 04h |
| Capture/compare control 2 | TB0CCTL2 | 06h |
| Capture/compare control 3 | TB0CCTL3 | 08h |
| Capture/compare control 4 | TB0CCTL4 | 0Ah |
| Capture/compare control 5 | TB0CCTL5 | 0Ch |
| Capture/compare control 6 | TB0CCTL6 | 0Eh |
| TB0 register | TB0R | 10h |
| Capture/compare register 0 | TB0CCR0 | 12h |
| Capture/compare register 1 | TB0CCR1 | 14h |
| Capture/compare register 2 | TB0CCR2 | 16h |
| Capture/compare register 3 | TB0CCR3 | 18h |
| Capture/compare register 4 | TB0CCR4 | 1Ah |
| Capture/compare register 5 | TB0CCR5 | 1Ch |
| Capture/compare register 6 | TB0CCR6 | 1Eh |
| TB0 expansion register 0 | TB0EX0 | 20h |
| TB0 interrupt vector | TB0IV | 2Eh |

Table 34. TA2 Registers (Base Address: 0400h)

| REGISTER DESCRIPTION | REGISTER | OFFSET |
|----------------------------|----------|--------|
| TA2 control | TA2CTL | 00h |
| Capture/compare control 0 | TA2CCTL0 | 02h |
| Capture/compare control 1 | TA2CCTL1 | 04h |
| Capture/compare control 2 | TA2CCTL2 | 06h |
| TA2 counter register | TA2R | 10h |
| Capture/compare register 0 | TA2CCR0 | 12h |
| Capture/compare register 1 | TA2CCR1 | 14h |
| Capture/compare register 2 | TA2CCR2 | 16h |
| TA2 expansion register 0 | TA2EX0 | 20h |
| TA2 interrupt vector | TA2IV | 2Eh |

Table 35. Real Time Clock Registers (Base Address: 04A0h)

| REGISTER DESCRIPTION | REGISTER | OFFSET |
|------------------------------------|----------------|--------|
| RTC control 0 | RTCCTL0 | 00h |
| RTC control 1 | RTCCTL1 | 01h |
| RTC control 2 | RTCCTL2 | 02h |
| RTC control 3 | RTCCTL3 | 03h |
| RTC prescaler 0 control | RTCPS0CTL | 08h |
| RTC prescaler 1 control | RTCPS1CTL | 0Ah |
| RTC prescaler 0 | RTCPS0 | 0Ch |
| RTC prescaler 1 | RTCPS1 | 0Dh |
| RTC interrupt vector word | RTCIV | 0Eh |
| RTC seconds/counter register 1 | RTCSEC/RTCNT1 | 10h |
| RTC minutes/counter register 2 | RTCMIN/RTCNT2 | 11h |
| RTC hours/counter register 3 | RTCHOUR/RTCNT3 | 12h |
| RTC day of week/counter register 4 | RTCDOW/RTCNT4 | 13h |
| RTC days | RTCDAY | 14h |
| RTC month | RTCMON | 15h |
| RTC year low | RTCYEARL | 16h |
| RTC year high | RTCYEARH | 17h |
| RTC alarm minutes | RTCAMIN | 18h |
| RTC alarm hours | RTCAHOUR | 19h |
| RTC alarm day of week | RTCADOW | 1Ah |
| RTC alarm days | RTCADAY | 1Bh |

Table 36. 32-Bit Hardware Multiplier Registers (Base Address: 04C0h)

| REGISTER DESCRIPTION | REGISTER | OFFSET |
|---|-----------|--------|
| 16-bit operand 1 – multiply | MPY | 00h |
| 16-bit operand 1 – signed multiply | MPYS | 02h |
| 16-bit operand 1 – multiply accumulate | MAC | 04h |
| 16-bit operand 1 – signed multiply accumulate | MACS | 06h |
| 16-bit operand 2 | OP2 | 08h |
| 16 × 16 result low word | RESLO | 0Ah |
| 16 × 16 result high word | RESHI | 0Ch |
| 16 × 16 sum extension register | SUMEXT | 0Eh |
| 32-bit operand 1 – multiply low word | MPY32L | 10h |
| 32-bit operand 1 – multiply high word | MPY32H | 12h |
| 32-bit operand 1 – signed multiply low word | MPYS32L | 14h |
| 32-bit operand 1 – signed multiply high word | MPYS32H | 16h |
| 32-bit operand 1 – multiply accumulate low word | MAC32L | 18h |
| 32-bit operand 1 – multiply accumulate high word | MAC32H | 1Ah |
| 32-bit operand 1 – signed multiply accumulate low word | MACS32L | 1Ch |
| 32-bit operand 1 – signed multiply accumulate high word | MACS32H | 1Eh |
| 32-bit operand 2 – low word | OP2L | 20h |
| 32-bit operand 2 – high word | OP2H | 22h |
| 32 × 32 result 0 – least significant word | RES0 | 24h |
| 32 × 32 result 1 | RES1 | 26h |
| 32 × 32 result 2 | RES2 | 28h |
| 32 × 32 result 3 – most significant word | RES3 | 2Ah |
| MPY32 control register 0 | MPY32CTL0 | 2Ch |

**Table 37. DMA Registers (Base Address DMA General Control: 0500h,
DMA Channel 0: 0510h, DMA Channel 1: 0520h, DMA Channel 2: 0530h)**

| REGISTER DESCRIPTION | REGISTER | OFFSET |
|--|----------|--------|
| DMA channel 0 control | DMA0CTL | 00h |
| DMA channel 0 source address low | DMA0SAL | 02h |
| DMA channel 0 source address high | DMA0SAH | 04h |
| DMA channel 0 destination address low | DMA0DAL | 06h |
| DMA channel 0 destination address high | DMA0DAH | 08h |
| DMA channel 0 transfer size | DMA0SZ | 0Ah |
| DMA channel 1 control | DMA1CTL | 00h |
| DMA channel 1 source address low | DMA1SAL | 02h |
| DMA channel 1 source address high | DMA1SAH | 04h |
| DMA channel 1 destination address low | DMA1DAL | 06h |
| DMA channel 1 destination address high | DMA1DAH | 08h |
| DMA channel 1 transfer size | DMA1SZ | 0Ah |
| DMA channel 2 control | DMA2CTL | 00h |
| DMA channel 2 source address low | DMA2SAL | 02h |
| DMA channel 2 source address high | DMA2SAH | 04h |
| DMA channel 2 destination address low | DMA2DAL | 06h |
| DMA channel 2 destination address high | DMA2DAH | 08h |
| DMA channel 2 transfer size | DMA2SZ | 0Ah |
| DMA module control 0 | DMACTL0 | 00h |
| DMA module control 1 | DMACTL1 | 02h |
| DMA module control 2 | DMACTL2 | 04h |
| DMA module control 3 | DMACTL3 | 06h |
| DMA module control 4 | DMACTL4 | 08h |
| DMA interrupt vector | DMAIV | 0Eh |

Table 38. USCI_A0 Registers (Base Address: 05C0h)

| REGISTER DESCRIPTION | REGISTER | OFFSET |
|----------------------------|------------|--------|
| USCI control 1 | UCA0CTL1 | 00h |
| USCI control 0 | UCA0CTL0 | 01h |
| USCI baud rate 0 | UCA0BR0 | 06h |
| USCI baud rate 1 | UCA0BR1 | 07h |
| USCI modulation control | UCA0MCTL | 08h |
| USCI status | UCA0STAT | 0Ah |
| USCI receive buffer | UCA0RXBUF | 0Ch |
| USCI transmit buffer | UCA0TXBUF | 0Eh |
| USCI LIN control | UCA0ABCTL | 10h |
| USCI IrDA transmit control | UCA0IRTCTL | 12h |
| USCI IrDA receive control | UCA0IRRCTL | 13h |
| USCI interrupt enable | UCA0IE | 1Ch |
| USCI interrupt flags | UCA0IFG | 1Dh |
| USCI interrupt vector word | UCA0IV | 1Eh |

Table 39. USCI_B0 Registers (Base Address: 05E0h)

| REGISTER DESCRIPTION | REGISTER | OFFSET |
|----------------------------------|-----------|--------|
| USCI synchronous control 1 | UCB0CTL1 | 00h |
| USCI synchronous control 0 | UCB0CTL0 | 01h |
| USCI synchronous bit rate 0 | UCB0BR0 | 06h |
| USCI synchronous bit rate 1 | UCB0BR1 | 07h |
| USCI synchronous status | UCB0STAT | 0Ah |
| USCI synchronous receive buffer | UCB0RXBUF | 0Ch |
| USCI synchronous transmit buffer | UCB0TXBUF | 0Eh |
| USCI I2C own address | UCB0I2COA | 10h |
| USCI I2C slave address | UCB0I2CSA | 12h |
| USCI interrupt enable | UCB0IE | 1Ch |
| USCI interrupt flags | UCB0IFG | 1Dh |
| USCI interrupt vector word | UCB0IV | 1Eh |

Table 40. USCI_A1 Registers (Base Address: 0600h)

| REGISTER DESCRIPTION | REGISTER | OFFSET |
|----------------------------|------------|--------|
| USCI control 1 | UCA1CTL1 | 00h |
| USCI control 0 | UCA1CTL0 | 01h |
| USCI baud rate 0 | UCA1BR0 | 06h |
| USCI baud rate 1 | UCA1BR1 | 07h |
| USCI modulation control | UCA1MCTL | 08h |
| USCI status | UCA1STAT | 0Ah |
| USCI receive buffer | UCA1RXBUF | 0Ch |
| USCI transmit buffer | UCA1TXBUF | 0Eh |
| USCI LIN control | UCA1ABCTL | 10h |
| USCI IrDA transmit control | UCA1IRTCTL | 12h |
| USCI IrDA receive control | UCA1IRRCTL | 13h |
| USCI interrupt enable | UCA1IE | 1Ch |
| USCI interrupt flags | UCA1IFG | 1Dh |
| USCI interrupt vector word | UCA1IV | 1Eh |

Table 41. USCI_B1 Registers (Base Address: 0620h)

| REGISTER DESCRIPTION | REGISTER | OFFSET |
|----------------------------------|-----------|--------|
| USCI synchronous control 1 | UCB1CTL1 | 00h |
| USCI synchronous control 0 | UCB1CTL0 | 01h |
| USCI synchronous bit rate 0 | UCB1BR0 | 06h |
| USCI synchronous bit rate 1 | UCB1BR1 | 07h |
| USCI synchronous status | UCB1STAT | 0Ah |
| USCI synchronous receive buffer | UCB1RXBUF | 0Ch |
| USCI synchronous transmit buffer | UCB1TXBUF | 0Eh |
| USCI I2C own address | UCB1I2COA | 10h |
| USCI I2C slave address | UCB1I2CSA | 12h |
| USCI interrupt enable | UCB1IE | 1Ch |
| USCI interrupt flags | UCB1IFG | 1Dh |
| USCI interrupt vector word | UCB1IV | 1Eh |

Table 42. ADC12_A Registers (Base Address: 0700h)

| REGISTER DESCRIPTION | REGISTER | OFFSET |
|--------------------------------|-------------|--------|
| Control register 0 | ADC12CTL0 | 00h |
| Control register 1 | ADC12CTL1 | 02h |
| Control register 2 | ADC12CTL2 | 04h |
| Interrupt-flag register | ADC12IFG | 0Ah |
| Interrupt-enable register | ADC12IE | 0Ch |
| Interrupt-vector-word register | ADC12IV | 0Eh |
| ADC memory-control register 0 | ADC12MCTL0 | 10h |
| ADC memory-control register 1 | ADC12MCTL1 | 11h |
| ADC memory-control register 2 | ADC12MCTL2 | 12h |
| ADC memory-control register 3 | ADC12MCTL3 | 13h |
| ADC memory-control register 4 | ADC12MCTL4 | 14h |
| ADC memory-control register 5 | ADC12MCTL5 | 15h |
| ADC memory-control register 6 | ADC12MCTL6 | 16h |
| ADC memory-control register 7 | ADC12MCTL7 | 17h |
| ADC memory-control register 8 | ADC12MCTL8 | 18h |
| ADC memory-control register 9 | ADC12MCTL9 | 19h |
| ADC memory-control register 10 | ADC12MCTL10 | 1Ah |
| ADC memory-control register 11 | ADC12MCTL11 | 1Bh |
| ADC memory-control register 12 | ADC12MCTL12 | 1Ch |
| ADC memory-control register 13 | ADC12MCTL13 | 1Dh |
| ADC memory-control register 14 | ADC12MCTL14 | 1Eh |
| ADC memory-control register 15 | ADC12MCTL15 | 1Fh |
| Conversion memory 0 | ADC12MEM0 | 20h |
| Conversion memory 1 | ADC12MEM1 | 22h |
| Conversion memory 2 | ADC12MEM2 | 24h |
| Conversion memory 3 | ADC12MEM3 | 26h |
| Conversion memory 4 | ADC12MEM4 | 28h |
| Conversion memory 5 | ADC12MEM5 | 2Ah |
| Conversion memory 6 | ADC12MEM6 | 2Ch |
| Conversion memory 7 | ADC12MEM7 | 2Eh |
| Conversion memory 8 | ADC12MEM8 | 30h |
| Conversion memory 9 | ADC12MEM9 | 32h |
| Conversion memory 10 | ADC12MEM10 | 34h |
| Conversion memory 11 | ADC12MEM11 | 36h |
| Conversion memory 12 | ADC12MEM12 | 38h |
| Conversion memory 13 | ADC12MEM13 | 3Ah |
| Conversion memory 14 | ADC12MEM14 | 3Ch |
| Conversion memory 15 | ADC12MEM15 | 3Eh |

Table 43. Comparator_B Registers (Base Address: 08C0h)

| REGISTER DESCRIPTION | REGISTER | OFFSET |
|------------------------------|----------|--------|
| Comp_B control register 0 | CBCTL0 | 00h |
| Comp_B control register 1 | CBCTL1 | 02h |
| Comp_B control register 2 | CBCTL2 | 04h |
| Comp_B control register 3 | CBCTL3 | 06h |
| Comp_B interrupt register | CBINT | 0Ch |
| Comp_B interrupt vector word | CBIV | 0Eh |

Table 44. LDO and Port U Configuration Registers (Base Address: 0900h)

| REGISTER DESCRIPTION | REGISTER | OFFSET |
|----------------------|-----------|--------|
| LDO key/ID register | LDOKEYPID | 00h |
| PU port control | PUCTL | 04h |
| LDO power control | LDOPWRCTL | 08h |

Absolute Maximum Ratings⁽¹⁾

over operating free-air temperature range (unless otherwise noted)

| | |
|--|----------------------------|
| Voltage applied at V_{CC} to V_{SS} | –0.3 V to 4.1 V |
| Voltage applied to any pin (excluding V _{CORE} , LDO1) ⁽²⁾ | –0.3 V to $V_{CC} + 0.3$ V |
| Diode current at any device pin | ±2 mA |
| Storage temperature range, T_{stg} ⁽³⁾ | –55°C to 150°C |

- (1) Stresses beyond those listed under "absolute maximum ratings" may cause permanent damage to the device. These are stress ratings only, and functional operation of the device at these or any other conditions beyond those indicated under "recommended operating conditions" is not implied. Exposure to absolute-maximum-rated conditions for extended periods may affect device reliability.
- (2) All voltages referenced to V_{SS} . V_{CORE} is for internal device usage only. No external DC loading or voltage should be applied.
- (3) Higher temperature may be applied during board soldering according to the current JEDEC J-STD-020 specification with peak reflow temperatures not higher than classified on the device label on the shipping boxes or reels.

Thermal Information

| THERMAL METRIC ⁽¹⁾ | | MSP430F5328-EP | UNITS |
|-------------------------------|---|----------------|-------|
| | | RGC | |
| | | 64 PINS | |
| θ_{JA} | Junction-to-ambient thermal resistance ⁽²⁾ | 30 | °C/W |
| θ_{JcTop} | Junction-to-case (top) thermal resistance ⁽³⁾ | 15.6 | |
| θ_{JB} | Junction-to-board thermal resistance ⁽⁴⁾ | 8.9 | |
| Ψ_{JT} | Junction-to-top characterization parameter ⁽⁵⁾ | 0.2 | |
| Ψ_{JB} | Junction-to-board characterization parameter ⁽⁶⁾ | 8.8 | |
| θ_{JcBot} | Junction-to-case (bottom) thermal resistance ⁽⁷⁾ | 1.6 | |

- (1) For more information about traditional and new thermal metrics, see the *IC Package Thermal Metrics* application report, [SPRA953](#).
- (2) The junction-to-ambient thermal resistance under natural convection is obtained in a simulation on a JEDEC-standard, high-K board, as specified in JESD51-7, in an environment described in JESD51-2a.
- (3) The junction-to-case (top) thermal resistance is obtained by simulating a cold plate test on the package top. No specific JEDEC-standard test exists, but a close description can be found in the ANSI SEMI standard G30-88.
- (4) The junction-to-board thermal resistance is obtained by simulating in an environment with a ring cold plate fixture to control the PCB temperature, as described in JESD51-8.
- (5) The junction-to-top characterization parameter, Ψ_{JT} , estimates the junction temperature of a device in a real system and is extracted from the simulation data for obtaining θ_{JA} , using a procedure described in JESD51-2a (sections 6 and 7).
- (6) The junction-to-board characterization parameter, Ψ_{JB} , estimates the junction temperature of a device in a real system and is extracted from the simulation data for obtaining θ_{JA} , using a procedure described in JESD51-2a (sections 6 and 7).
- (7) The junction-to-case (bottom) thermal resistance is obtained by simulating a cold plate test on the exposed (power) pad. No specific JEDEC standard test exists, but a close description can be found in the ANSI SEMI standard G30-88.

Recommended Operating Conditions

Typical values are specified at $V_{CC} = 3.3\text{ V}$ and $T_A = 25^\circ\text{C}$ (unless otherwise noted)

| | | MIN | NOM | MAX | UNIT |
|----------------------------|---|---|-----|------|------|
| V_{CC} | Supply voltage during program execution and flash programming($AV_{CCx} = DV_{CCx} = V_{CC}$) ⁽¹⁾⁽²⁾ | PMMCOREVx = 0 | 1.8 | 3.6 | V |
| | | PMMCOREVx = 0, 1 | 2.0 | 3.6 | V |
| | | PMMCOREVx = 0, 1, 2 | 2.2 | 3.6 | V |
| | | PMMCOREVx = 0, 1, 2, 3 | 2.4 | 3.6 | V |
| V_{SS} | Supply voltage ($AV_{SSx} = DV_{SSx} = V_{SS}$) | | 0 | | V |
| T_J | Operating junction temperature | -40 | | 105 | °C |
| $C_{V_{CORE}}$ | Recommended capacitor at V _{CORE} | | 470 | | nF |
| $C_{DV_{CC}}/C_{V_{CORE}}$ | Capacitor ratio of DV _{CC} to V _{CORE} | 10 | | | |
| f_{SYSTEM} | Processor frequency (maximum MCLK frequency) ⁽³⁾ (see Figure 1) | PMMCOREVx = 0, 1.8 V ≤ V_{CC} ≤ 3.6 V (default condition) | 0 | 8.0 | MHz |
| | | PMMCOREVx = 1, 2.0 V ≤ V_{CC} ≤ 3.6 V | 0 | 12.0 | |
| | | PMMCOREVx = 2, 2.2 V ≤ V_{CC} ≤ 3.6 V | 0 | 20.0 | |
| | | PMMCOREVx = 3, 2.4 V ≤ V_{CC} ≤ 3.6 V | 0 | 25.0 | |

- (1) It is recommended to power AV_{CC} and DV_{CC} from the same source. A maximum difference of 0.3 V between AV_{CC} and DV_{CC} can be tolerated during power up and operation.
- (2) The minimum supply voltage is defined by the supervisor SVS levels when it is enabled. See the [PMM](#), [SVS High Side](#) threshold parameters for the exact values and further details.
- (3) Modules may have a different maximum input clock specification. See the specification of the respective module in this data sheet.

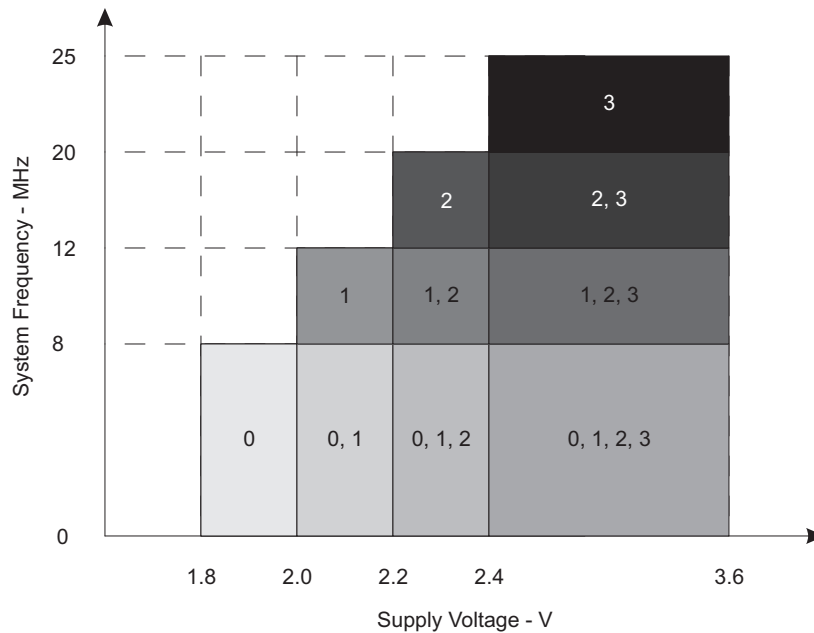

The numbers within the fields denote the supported PMMCOREVx settings.

Figure 1. Maximum System Frequency

Electrical Characteristics

Active Mode Supply Current Into V_{CC} Excluding External Current

over recommended operating free-air temperature (unless otherwise noted)⁽¹⁾ ⁽²⁾ ⁽³⁾

| PARAMETER | EXECUTION MEMORY | V_{CC} | PMMCOREVx | FREQUENCY ($f_{DCO} = f_{MCLK} = f_{SMCLK}$) | | | | | | | | | | UNIT |
|-----------------|------------------|----------|-----------|--|------|-------|------|--------|-----|--------|-----|--------|------|------|
| | | | | 1 MHz | | 8 MHz | | 12 MHz | | 20 MHz | | 25 MHz | | |
| | | | | TYP | MAX | TYP | MAX | TYP | MAX | TYP | MAX | TYP | MAX | |
| $I_{AM, Flash}$ | Flash | 3 V | 0 | 0.36 | 0.47 | 2.32 | 2.60 | | | | | | | mA |
| | | | 1 | 0.40 | | 2.65 | | 4.0 | 4.4 | | | | | |
| | | | 2 | 0.44 | | 2.90 | | 4.3 | | 7.1 | 7.7 | | | |
| | | | 3 | 0.46 | | 3.10 | | 4.6 | | 7.6 | | 10.1 | 11.0 | |
| $I_{AM, RAM}$ | RAM | 3 V | 0 | 0.20 | 0.24 | 1.20 | 1.40 | | | | | | | mA |
| | | | 1 | 0.22 | | 1.35 | | 2.0 | 2.2 | | | | | |
| | | | 2 | 0.24 | | 1.50 | | 2.2 | | 3.7 | 4.5 | | | |
| | | | 3 | 0.26 | | 1.60 | | 2.4 | | 3.9 | | 5.3 | 6.2 | |

(1) All inputs are tied to 0 V or to V_{CC} . Outputs do not source or sink any current.

(2) The currents are characterized with a Micro Crystal MS1V-T1K crystal with a load capacitance of 12.5 pF. The internal and external load capacitance are chosen to closely match the required 12.5 pF.

(3) Characterized with program executing typical data processing. LDO disabled (LDOEN = 0).

$f_{ACLK} = 32786$ Hz, $f_{DCO} = f_{MCLK} = f_{SMCLK}$ at specified frequency.

XTS = CPUOFF = SCG0 = SCG1 = OSCOFF = SMCLKOFF = 0.

Low-Power Mode Supply Currents (Into V_{CC}) Excluding External Current

 over recommended ranges of supply voltage and operating free-air temperature (unless otherwise noted)^{(1) (2)}

| PARAMETER | V_{CC} | PMMCOREVx | -40 °C | | 25 °C | | 60 °C | | 105 °C | | UNIT |
|--|----------|-----------|--------|------|-------|------|-------|-----|---------|---------|------|
| | | | TYP | MAX | TYP | MAX | TYP | MAX | TYP | MAX | |
| $I_{LPM0,1MHz}$ Low-power mode 0 ^{(3) (4)} | 2.2 V | 0 | 73 | 77 | 85 | 80 | 85 | 101 | | μA | |
| | 3 V | 3 | 79 | 83 | 92 | 88 | 95 | 18 | | | |
| I_{LPM2} Low-power mode 2 ^{(5) (4)} | 2.2 V | 0 | 6.5 | 6.5 | 12 | 10 | 11 | 22 | | μA | |
| | 3 V | 3 | 7.0 | 7.0 | 13 | 11 | 12 | 24 | | | |
| $I_{LPM3,XT1LF}$ Low-power mode 3, crystal mode ^{(6) (4)} | 2.2 V | 0 | 1.60 | 1.90 | | 2.6 | 5.6 | | | μA | |
| | | 1 | 1.65 | 2.00 | | 2.7 | 5.9 | | | | |
| | | 2 | 1.75 | 2.15 | | 2.9 | 6.1 | | | | |
| | 3 V | 0 | 1.8 | 2.1 | 2.9 | 2.8 | 5.8 | 18 | | | |
| | | 1 | 1.9 | 2.3 | | 2.9 | 6.1 | | | | |
| | | 2 | 2.0 | 2.4 | | 3.0 | 6.3 | | | | |
| $I_{LPM3,VLO}$ Low-power mode 3, VLO mode ^{(7) (4)} | 3 V | 3 | 2.0 | 2.5 | 3.9 | 3.1 | 6.4 | 20 | | | |
| | | 0 | 1.1 | 1.4 | 2.7 | 1.9 | 4.9 | 17 | | | |
| | | 1 | 1.1 | 1.4 | | 2.0 | 5.2 | | | | |
| | | 2 | 1.2 | 1.5 | | 2.1 | 5.3 | | | | |
| I_{LPM4} Low-power mode 4 ^{(8) (4)} | 3 V | 3 | 1.3 | 1.6 | | 2.2 | 5.4 | 19 | | | |
| | | 0 | 0.9 | 1.1 | 1.5 | 1.8 | 4.8 | 17 | | | |
| | | 1 | 1.1 | 1.2 | | 2.0 | 5.1 | | | | |
| | | 2 | 1.2 | 1.2 | | 2.1 | 5.2 | | | | |
| $I_{LPM4.5}$ Low-power mode 4.5 ⁽⁹⁾ | 3 V | | 0.15 | 0.18 | 0.35 | 0.26 | 0.5 | 1.8 | μA | | |

- (1) All inputs are tied to 0 V or to V_{CC} . Outputs do not source or sink any current.
- (2) The currents are characterized with a Micro Crystal MS1V-T1K crystal with a load capacitance of 12.5 pF. The internal and external load capacitance are chosen to closely match the required 12.5 pF.
- (3) Current for watchdog timer clocked by SMCLK included. ACLK = low frequency crystal operation (XTS = 0, XT1DRIVEx = 0). CPUOFF = 1, SCG0 = 0, SCG1 = 0, OSCOFF = 0 (LPM0); f_{ACLK} = 32768 Hz, f_{MCLK} = 0 MHz, f_{SMCLK} = f_{DCO} = 1 MHz LDO disabled (LDOEN = 0).
- (4) Current for brownout, high side supervisor (SVSH) normal mode included. Low side supervisor and monitors disabled (SVSL, SVML). High side monitor disabled (SVMH). RAM retention enabled.
- (5) Current for watchdog timer and RTC clocked by ACLK included. ACLK = low frequency crystal operation (XTS = 0, XT1DRIVEx = 0). CPUOFF = 1, SCG0 = 0, SCG1 = 1, OSCOFF = 0 (LPM2); f_{ACLK} = 32768 Hz, f_{MCLK} = 0 MHz, f_{SMCLK} = f_{DCO} = 0 MHz; DCO setting = 1 MHz operation, DCO bias generator enabled.) LDO disabled (LDOEN = 0).
- (6) Current for watchdog timer and RTC clocked by ACLK included. ACLK = low frequency crystal operation (XTS = 0, XT1DRIVEx = 0). CPUOFF = 1, SCG0 = 1, SCG1 = 1, OSCOFF = 0 (LPM3); f_{ACLK} = 32768 Hz, f_{MCLK} = f_{SMCLK} = f_{DCO} = 0 MHz LDO disabled (LDOEN = 0).
- (7) Current for watchdog timer and RTC clocked by ACLK included. ACLK = VLO. CPUOFF = 1, SCG0 = 1, SCG1 = 1, OSCOFF = 0 (LPM3); f_{ACLK} = f_{VLO} , f_{MCLK} = f_{SMCLK} = f_{DCO} = 0 MHz LDO disabled (LDOEN = 0).
- (8) CPUOFF = 1, SCG0 = 1, SCG1 = 1, OSCOFF = 1 (LPM4); f_{DCO} = f_{ACLK} = f_{MCLK} = f_{SMCLK} = 0 MHz LDO disabled (LDOEN = 0).
- (9) Internal regulator disabled. No data retention. CPUOFF = 1, SCG0 = 1, SCG1 = 1, OSCOFF = 1, PMMREGOFF = 1 (LPM4.5); f_{DCO} = f_{ACLK} = f_{MCLK} = f_{SMCLK} = 0 MHz

Schmitt-Trigger Inputs – General Purpose I/O⁽¹⁾ (P1.0 to P1.7, P2.0 to P2.7, P3.0 to P3.7, P4.0 to P4.7) (P5.0 to P5.7, P6.0 to P6.7, P7.0 to P7.7, P8.0 to P8.2, PJ.0 to PJ.3, $\overline{\text{RST/NMI}}$)

over recommended ranges of supply voltage and operating free-air temperature (unless otherwise noted)

| PARAMETER | | TEST CONDITIONS | V _{CC} | MIN | TYP | MAX | UNIT |
|-------------------|---|--|-----------------|------|-----|------|------|
| V _{IT+} | Positive-going input threshold voltage | | 1.8 V | 0.80 | | 1.40 | V |
| | | | 3 V | 1.50 | | 2.10 | |
| V _{IT-} | Negative-going input threshold voltage | | 1.8 V | 0.45 | | 1.00 | V |
| | | | 3 V | 0.75 | | 1.65 | |
| V _{hys} | Input voltage hysteresis (V _{IT+} – V _{IT-}) | | 1.8 V | 0.3 | | 0.8 | V |
| | | | 3 V | 0.4 | | 1.0 | |
| R _{Pull} | Pullup/pulldown resistor ⁽²⁾ | For pullup: V _{IN} = V _{SS} For pulldown: V _{IN} = V _{CC} | | 20 | 35 | 50 | kΩ |
| C _I | Input capacitance | V _{IN} = V _{SS} or V _{CC} | | | 5 | | pF |

(1) Same parametrics apply to clock input pin when crystal bypass mode is used on XT1 (XIN) or XT2 (XT2IN).

(2) Also applies to $\overline{\text{RST}}$ pin when pullup/pulldown resistor is enabled.

Inputs – Ports P1 and P2⁽¹⁾ (P1.0 to P1.7, P2.0 to P2.7)

over recommended ranges of supply voltage and operating free-air temperature (unless otherwise noted)

| PARAMETER | TEST CONDITIONS | V _{CC} | MIN | MAX | UNIT |
|--------------------|--|--|------------|-----|------|
| t _(int) | External interrupt timing ⁽²⁾ | External trigger pulse width to set interrupt flag | 2.2 V, 3 V | 20 | ns |

(1) Some devices may contain additional ports with interrupts. See the block diagram and terminal function descriptions.

(2) An external signal sets the interrupt flag every time the minimum interrupt pulse width t_(int) is met. It may be set by trigger signals shorter than t_(int).

Leakage Current – General Purpose I/O (P1.0 to P1.7, P2.0 to P2.7, P3.0 to P3.7, P4.0 to P4.7) (P5.0 to P5.7, P6.0 to P6.7, P7.0 to P7.7, P8.0 to P8.2, PJ.0 to PJ.3, $\overline{\text{RST/NMI}}$)

over recommended ranges of supply voltage and operating free-air temperature (unless otherwise noted)

| PARAMETER | TEST CONDITIONS | V _{CC} | MIN | MAX | UNIT |
|------------------------|--------------------------------|-------------------------------|------------|-----|------|
| I _{lkg(Px.x)} | High-impedance leakage current | ⁽¹⁾ ⁽²⁾ | 1.8 V, 3 V | ±50 | nA |

(1) The leakage current is measured with V_{SS} or V_{CC} applied to the corresponding pin(s), unless otherwise noted.

(2) The leakage of the digital port pins is measured individually. The port pin is selected for input and the pullup/pulldown resistor is disabled.

Outputs – General Purpose I/O (Full Drive Strength) (P1.0 to P1.7, P2.0 to P2.7, P3.0 to P3.7, P4.0 to P4.7) (P5.0 to P5.7, P6.0 to P6.7, P7.0 to P7.7, P8.0 to P8.2, PJ.0 to PJ.3)

over recommended ranges of supply voltage and operating free-air temperature (unless otherwise noted)

| PARAMETER | TEST CONDITIONS | V _{CC} | MIN | MAX | UNIT | |
|-----------------|---------------------------|-----------------|--|------------------------|------------------------|---|
| V _{OH} | High-level output voltage | 1.8 V | I _(OHmax) = –3 mA ⁽¹⁾ | V _{CC} – 0.25 | V _{CC} | V |
| | | | I _(OHmax) = –10 mA ⁽²⁾ | V _{CC} – 0.60 | V _{CC} | |
| | | 3 V | I _(OHmax) = –5 mA ⁽¹⁾ | V _{CC} – 0.25 | V _{CC} | |
| | | | I _(OHmax) = –15 mA ⁽²⁾ | V _{CC} – 0.60 | V _{CC} | |
| V _{OL} | Low-level output voltage | 1.8 V | I _(OLmax) = 3 mA ⁽¹⁾ | V _{SS} | V _{SS} + 0.25 | V |
| | | | I _(OLmax) = 10 mA ⁽²⁾ | V _{SS} | V _{SS} + 0.60 | |
| | | 3 V | I _(OLmax) = 5 mA ⁽¹⁾ | V _{SS} | V _{SS} + 0.25 | |
| | | | I _(OLmax) = 15 mA ⁽²⁾ | V _{SS} | V _{SS} + 0.60 | |

(1) The maximum total current, I_(OHmax) and I_(OLmax), for all outputs combined should not exceed ±48 mA to hold the maximum voltage drop specified.

(2) The maximum total current, I_(OHmax) and I_(OLmax), for all outputs combined should not exceed ±100 mA to hold the maximum voltage drop specified.

**Outputs – General Purpose I/O (Reduced Drive Strength)
(P1.0 to P1.7, P2.0 to P2.7, P3.0 to P3.7, P4.0 to P4.7)
(P5.0 to P5.7, P6.0 to P6.7, P7.0 to P7.7, P8.0 to P8.2, PJ.0 to PJ.3)**

over recommended ranges of supply voltage and operating free-air temperature (unless otherwise noted)⁽¹⁾

| PARAMETER | | TEST CONDITIONS | V _{CC} | MIN | MAX | UNIT |
|-----------------|---------------------------|---|-----------------|------------------------|------------------------|------|
| V _{OH} | High-level output voltage | I _(OHmax) = -1 mA ⁽²⁾ | 1.8 V | V _{CC} - 0.25 | V _{CC} | V |
| | | I _(OHmax) = -3 mA ⁽³⁾ | | V _{CC} - 0.60 | V _{CC} | |
| | | I _(OHmax) = -2 mA ⁽²⁾ | 3 V | V _{CC} - 0.25 | V _{CC} | |
| | | I _(OHmax) = -6 mA ⁽³⁾ | | V _{CC} - 0.60 | V _{CC} | |
| V _{OL} | Low-level output voltage | I _(OLmax) = 1 mA ⁽²⁾ | 1.8 V | V _{SS} | V _{SS} + 0.25 | V |
| | | I _(OLmax) = 3 mA ⁽³⁾ | | V _{SS} | V _{SS} + 0.60 | |
| | | I _(OLmax) = 2 mA ⁽²⁾ | 3 V | V _{SS} | V _{SS} + 0.25 | |
| | | I _(OLmax) = 6 mA ⁽³⁾ | | V _{SS} | V _{SS} + 0.60 | |

(1) Selecting reduced drive strength may reduce EMI.

(2) The maximum total current, I_(OHmax) and I_(OLmax), for all outputs combined, should not exceed ±48 mA to hold the maximum voltage drop specified.

(3) The maximum total current, I_(OHmax) and I_(OLmax), for all outputs combined, should not exceed ±100 mA to hold the maximum voltage drop specified.

**Output Frequency – General Purpose I/O
(P1.0 to P1.7, P2.0 to P2.7, P3.0 to P3.7, P4.0 to P4.7)
(P5.0 to P5.7, P6.0 to P6.7, P7.0 to P7.7, P8.0 to P8.2, PJ.0 to PJ.3)**

over recommended ranges of supply voltage and operating free-air temperature (unless otherwise noted)

| PARAMETER | | TEST CONDITIONS | MIN | MAX | UNIT |
|-----------------------|-----------------------------------|--|--|--------------------------------------|------|
| f _{Px,y} | Port output frequency (with load) | ⁽¹⁾⁽²⁾ V _{CC} = 1.8 V, PMMCOREVx = 0 | | 16 | MHz |
| | | V _{CC} = 3 V, PMMCOREVx = 3 | | 25 | |
| f _{Port_CLK} | Clock output frequency | ACLK, SMCLK, MCLK, C _L = 20 pF ⁽²⁾ | V _{CC} = 1.8 V, PMMCOREVx = 0 | | 16 |
| | | | | V _{CC} = 3 V, PMMCOREVx = 3 | |

(1) A resistive divider with 2 × R1 between V_{CC} and V_{SS} is used as load. The output is connected to the center tap of the divider. For full drive strength, R1 = 550 Ω. For reduced drive strength, R1 = 1.6 kΩ. C_L = 20 pF is connected to the output to V_{SS}.

(2) The output voltage reaches at least 10% and 90% V_{CC} at the specified toggle frequency.

Typical Characteristics – Outputs, Reduced Drive Strength (PxDS.y = 0)

over recommended ranges of supply voltage and operating free-air temperature (unless otherwise noted)

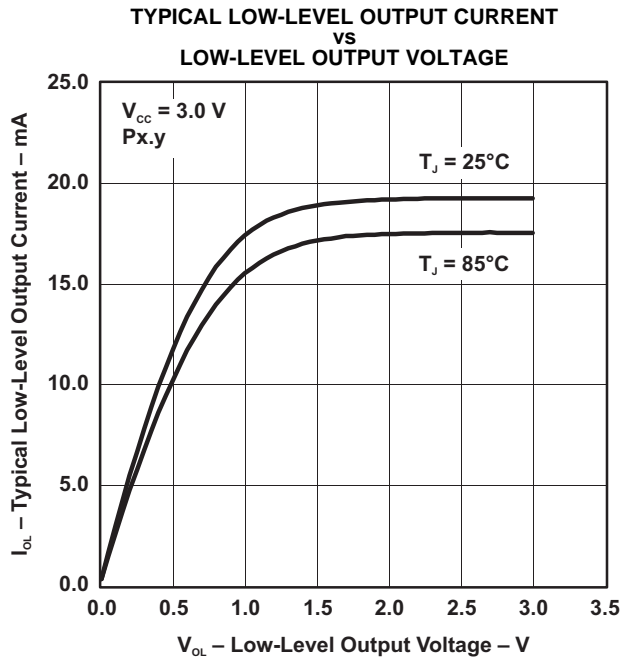

Figure 2.

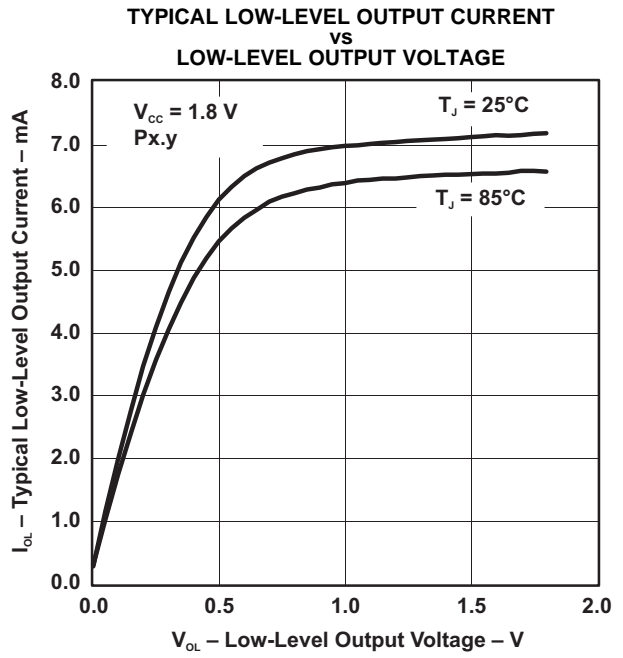

Figure 3.

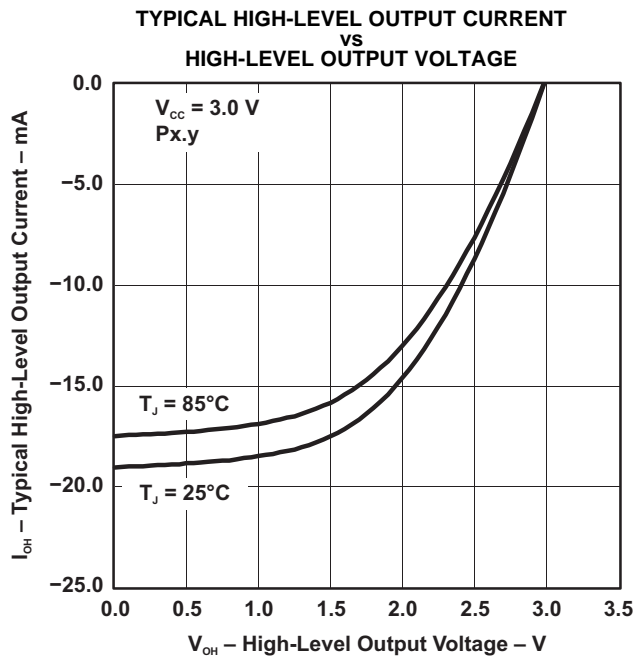

Figure 4.

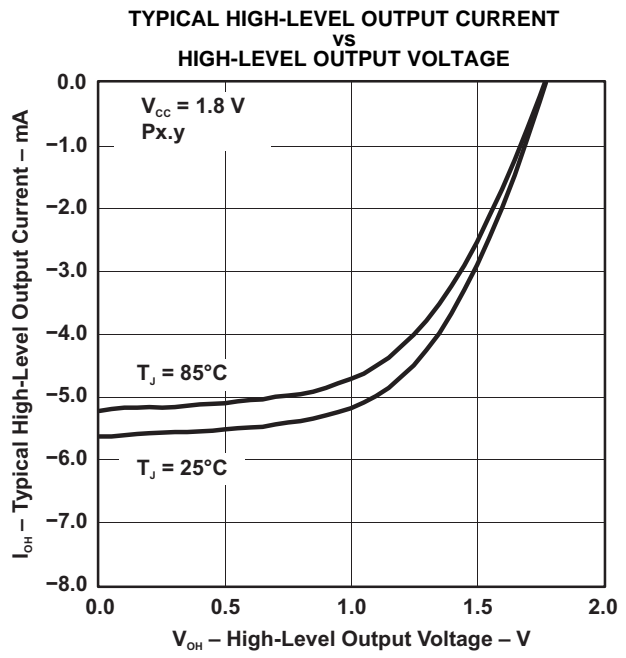

Figure 5.

Typical Characteristics – Outputs, Full Drive Strength (PxDS.y = 1)

over recommended ranges of supply voltage and operating free-air temperature (unless otherwise noted)

TYPICAL LOW-LEVEL OUTPUT CURRENT vs LOW-LEVEL OUTPUT VOLTAGE

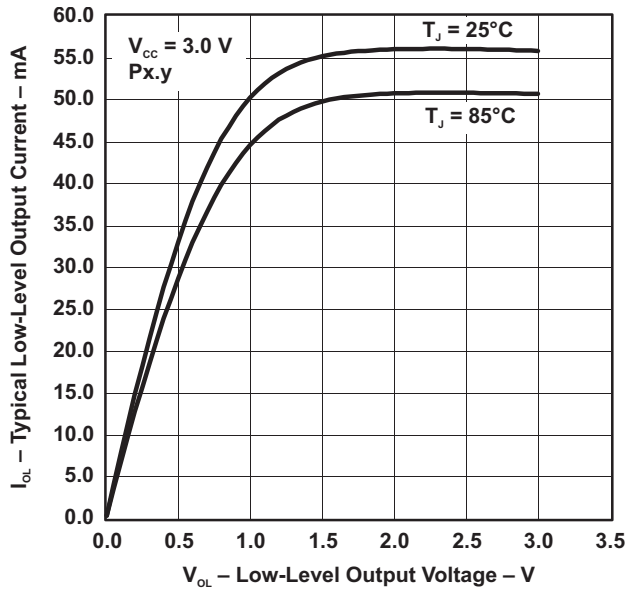

Figure 6.

TYPICAL LOW-LEVEL OUTPUT CURRENT vs LOW-LEVEL OUTPUT VOLTAGE

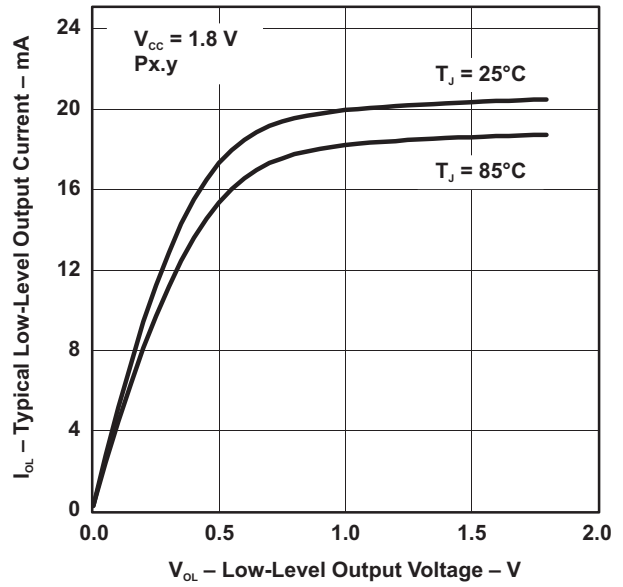

Figure 7.

TYPICAL HIGH-LEVEL OUTPUT CURRENT vs HIGH-LEVEL OUTPUT VOLTAGE

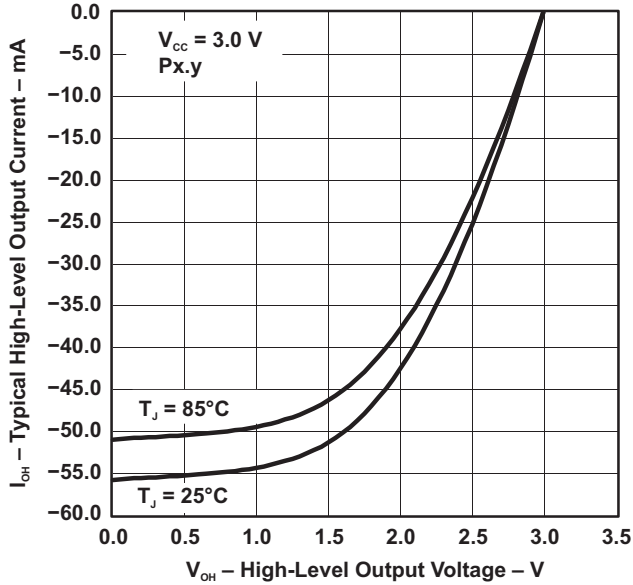

Figure 8.

TYPICAL HIGH-LEVEL OUTPUT CURRENT vs HIGH-LEVEL OUTPUT VOLTAGE

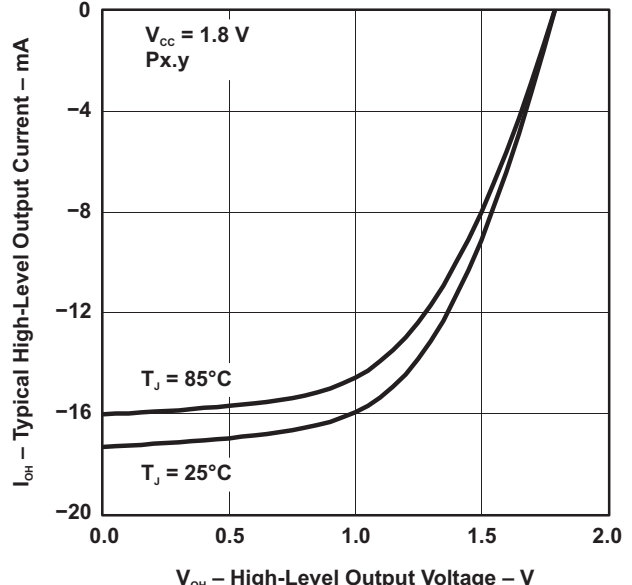

Figure 9.

Crystal Oscillator, XT1, Low-Frequency Mode⁽¹⁾⁽²⁾

over recommended ranges of supply voltage and -40°C to 85°C (unless otherwise noted)

| PARAMETER | TEST CONDITIONS | V _{CC} | MIN | TYP | MAX | UNIT | |
|----------------------|--|-----------------|-----|--------|-------|------------|---|
| $\Delta I_{DVCC,LF}$ | Differential XT1 oscillator crystal current consumption from lowest drive setting, LF mode | 3 V | | 0.075 | | μA | |
| | $f_{OSC} = 32768$ Hz, XTS = 0, XT1BYPASS = 0, XT1DRIVE _x = 1, T _A = 25°C | | | | | | |
| | $f_{OSC} = 32768$ Hz, XTS = 0, XT1BYPASS = 0, XT1DRIVE _x = 2, T _A = 25°C | | | | | | |
| | $f_{OSC} = 32768$ Hz, XTS = 0, XT1BYPASS = 0, XT1DRIVE _x = 3, T _A = 25°C | | | 0.290 | | | |
| $f_{XT1,LF0}$ | XT1 oscillator crystal frequency, LF mode | | | 32768 | | Hz | |
| $f_{XT1,LF,SW}$ | XT1 oscillator logic-level square-wave input frequency, LF mode | | 10 | 32.768 | 50 | kHz | |
| OA_{LF} | Oscillation allowance for LF crystals ⁽⁵⁾ | | | 210 | | k Ω | |
| | | | | | | | XTS = 0, XT1BYPASS = 0, XT1DRIVE _x = 0, $f_{XT1,LF} = 32768$ Hz, C _{L,eff} = 6 pF |
| | XTS = 0, XT1BYPASS = 0, XT1DRIVE _x = 1, $f_{XT1,LF} = 32768$ Hz, C _{L,eff} = 12 pF | | | 300 | | | |
| $C_{L,eff}$ | Integrated effective load capacitance, LF mode ⁽⁶⁾ | | | | | pF | |
| | | | | | | | XTS = 0, XCAP _x = 0 ⁽⁷⁾ |
| | | | | | | | XTS = 0, XCAP _x = 1 |
| | | | | | | | XTS = 0, XCAP _x = 2 |
| | XTS = 0, XCAP _x = 3 | | | 12.0 | | | |
| | Duty cycle, LF mode | | 30 | | 70 | % | |
| $f_{Fault,LF}$ | Oscillator fault frequency, LF mode ⁽⁸⁾ | | 10 | | 10000 | Hz | |
| $t_{START,LF}$ | Startup time, LF mode | 3 V | | 1000 | | ms | |
| | | | | | | | $f_{OSC} = 32768$ Hz, XTS = 0, XT1BYPASS = 0, XT1DRIVE _x = 0, T _A = 25°C, C _{L,eff} = 6 pF |
| | $f_{OSC} = 32768$ Hz, XTS = 0, XT1BYPASS = 0, XT1DRIVE _x = 3, T _A = 25°C, C _{L,eff} = 12 pF | | | 500 | | | |

- (1) To improve EMI on the XT1 oscillator, the following guidelines should be observed.
 - (a) Keep the trace between the device and the crystal as short as possible.
 - (b) Design a good ground plane around the oscillator pins.
 - (c) Prevent crosstalk from other clock or data lines into oscillator pins XIN and XOUT.
 - (d) Avoid running PCB traces underneath or adjacent to the XIN and XOUT pins.
 - (e) Use assembly materials and praxis to avoid any parasitic load on the oscillator XIN and XOUT pins.
 - (f) If conformal coating is used, ensure that it does not induce capacitive/resistive leakage between the oscillator pins.
- (2) Functional block is tested for full temperature range, but parametric values are ensured for -40°C to 85°C.
- (3) When XT1BYPASS is set, XT1 circuits are automatically powered down. Input signal is a digital square wave with parametrics defined in the Schmitt-trigger Inputs section of this datasheet.
- (4) Maximum frequency of operation of the entire device cannot be exceeded.
- (5) Oscillation allowance is based on a safety factor of 5 for recommended crystals. The oscillation allowance is a function of the XT1DRIVE_x settings and the effective load. In general, comparable oscillator allowance can be achieved based on the following guidelines, but should be evaluated based on the actual crystal selected for the application:
 - (a) For XT1DRIVE_x = 0, C_{L,eff} ≤ 6 pF
 - (b) For XT1DRIVE_x = 1, 6 pF ≤ C_{L,eff} ≤ 9 pF
 - (c) For XT1DRIVE_x = 2, 6 pF ≤ C_{L,eff} ≤ 10 pF
 - (d) For XT1DRIVE_x = 3, C_{L,eff} ≥ 6 pF
- (6) Includes parasitic bond and package capacitance (approximately 2 pF per pin).
Since the PCB adds additional capacitance, it is recommended to verify the correct load by measuring the ACLK frequency. For a correct setup, the effective load capacitance should always match the specification of the used crystal.
- (7) Requires external capacitors at both terminals. Values are specified by crystal manufacturers.
- (8) Frequencies below the MIN specification set the fault flag. Frequencies above the MAX specification do not set the fault flag. Frequencies in between might set the flag.
- (9) Measured with logic-level input frequency but also applies to operation with crystals.

Crystal Oscillator, XT2⁽¹⁾

over recommended ranges of supply voltage and -40°C to 85°C (unless otherwise noted)^{(2) (3)}

| PARAMETER | TEST CONDITIONS | V _{CC} | MIN | TYP | MAX | UNIT |
|--|--|-----------------|-----|-----|-----|------|
| I _{DVCC,XT2} XT2 oscillator crystal current consumption | f _{OSC} = 4 MHz, XT2OFF = 0, XT2BYPASS = 0, XT2DRIVE _x = 0, T _A = 25°C | 3 V | | 200 | | μA |
| | f _{OSC} = 12 MHz, XT2OFF = 0, XT2BYPASS = 0, XT2DRIVE _x = 1, T _A = 25°C | | | 260 | | |
| | f _{OSC} = 20 MHz, XT2OFF = 0, XT2BYPASS = 0, XT2DRIVE _x = 2, T _A = 25°C | | | 325 | | |
| | f _{OSC} = 32 MHz, XT2OFF = 0, XT2BYPASS = 0, XT2DRIVE _x = 3, T _A = 25°C | | | 450 | | |
| f _{XT2,HF0} XT2 oscillator crystal frequency, mode 0 | XT2DRIVE _x = 0, XT2BYPASS = 0 ⁽⁴⁾ | | 4 | | 8 | MHz |
| f _{XT2,HF1} XT2 oscillator crystal frequency, mode 1 | XT2DRIVE _x = 1, XT2BYPASS = 0 ⁽⁴⁾ | | 8 | | 16 | MHz |
| f _{XT2,HF2} XT2 oscillator crystal frequency, mode 2 | XT2DRIVE _x = 2, XT2BYPASS = 0 ⁽⁴⁾ | | 16 | | 24 | MHz |
| f _{XT2,HF3} XT2 oscillator crystal frequency, mode 3 | XT2DRIVE _x = 3, XT2BYPASS = 0 ⁽⁴⁾ | | 24 | | 32 | MHz |
| f _{XT2,HF,SW} XT2 oscillator logic-level square-wave input frequency, bypass mode | XT2BYPASS = 1 ^{(5) (4)} | | 0.7 | | 32 | MHz |
| O _{AHF} Oscillation allowance for HF crystals ⁽⁶⁾ | XT2DRIVE _x = 0, XT2BYPASS = 0, f _{XT2,HF0} = 6 MHz, C _{L,eff} = 15 pF | | | 450 | | Ω |
| | XT2DRIVE _x = 1, XT2BYPASS = 0, f _{XT2,HF1} = 12 MHz, C _{L,eff} = 15 pF | | | 320 | | |
| | XT2DRIVE _x = 2, XT2BYPASS = 0, f _{XT2,HF2} = 20 MHz, C _{L,eff} = 15 pF | | | 200 | | |
| | XT2DRIVE _x = 3, XT2BYPASS = 0, f _{XT2,HF3} = 32 MHz, C _{L,eff} = 15 pF | | | 200 | | |
| t _{START,HF} Startup time | f _{OSC} = 6 MHz, XT2BYPASS = 0, XT2DRIVE _x = 0, T _A = 25°C, C _{L,eff} = 15 pF | 3 V | | 0.5 | | ms |
| | f _{OSC} = 20 MHz, XT2BYPASS = 0, XT2DRIVE _x = 2, T _A = 25°C, C _{L,eff} = 15 pF | | | 0.3 | | |
| C _{L,eff} Integrated effective load capacitance, HF mode ^{(7) (2)} | | | | 1 | | pF |
| Duty cycle, HF mode | Measured at ACLK, f _{XT2,HF2} = 20 MHz | | 40 | 50 | 60 | % |

(1) Functional block is tested for full temperature range, but parametric values are ensured for -40°C to 85°C.

(2) Requires external capacitors at both terminals. Values are specified by crystal manufacturers. In general, an effective load capacitance of up to 18 pF can be supported.

(3) To improve EMI on the XT2 oscillator the following guidelines should be observed.

(a) Keep the traces between the device and the crystal as short as possible.

(b) Design a good ground plane around the oscillator pins.

(c) Prevent crosstalk from other clock or data lines into oscillator pins XT2IN and XT2OUT.

(d) Avoid running PCB traces underneath or adjacent to the XT2IN and XT2OUT pins.

(e) Use assembly materials and praxis to avoid any parasitic load on the oscillator XT2IN and XT2OUT pins.

(f) If conformal coating is used, ensure that it does not induce capacitive/resistive leakage between the oscillator pins.

(4) This represents the maximum frequency that can be input to the device externally. Maximum frequency achievable on the device operation is based on the frequencies present on ACLK, MCLK, and SMCLK cannot be exceeded for a given range of operation.

(5) When XT2BYPASS is set, the XT2 circuit is automatically powered down. Input signal is a digital square wave with parametrics defined in the Schmitt-trigger Inputs section of this datasheet.

(6) Oscillation allowance is based on a safety factor of 5 for recommended crystals.

(7) Includes parasitic bond and package capacitance (approximately 2 pF per pin).

Since the PCB adds additional capacitance, it is recommended to verify the correct load by measuring the ACLK frequency. For a correct setup, the effective load capacitance should always match the specification of the used crystal.

Crystal Oscillator, XT2⁽¹⁾ (continued)

over recommended ranges of supply voltage and -40°C to 85°C (unless otherwise noted)⁽²⁾ ⁽³⁾

| PARAMETER | | TEST CONDITIONS | V _{CC} | MIN | TYP | MAX | UNIT |
|------------------------|---|------------------------------|-----------------|-----|-----|-----|------|
| f _{Fault, HF} | Oscillator fault frequency ⁽⁸⁾ | XT2BYPASS = 1 ⁽⁹⁾ | | 30 | | 300 | kHz |

(8) Frequencies below the MIN specification set the fault flag. Frequencies above the MAX specification do not set the fault flag. Frequencies in between might set the flag.

(9) Measured with logic-level input frequency but also applies to operation with crystals.

Internal Very-Low-Power Low-Frequency Oscillator (VLO)

over recommended ranges of supply voltage and operating free-air temperature (unless otherwise noted)

| PARAMETER | | TEST CONDITIONS | V _{CC} | MIN | TYP | MAX | UNIT |
|-------------------------------------|------------------------------------|---------------------------------|-----------------|-----|-----|------|------|
| f _{VLO} | VLO frequency | Measured at ACLK | 1.8 V to 3.6 V | 6 | 9.4 | 14.5 | kHz |
| df _{VLO} /dT | VLO frequency temperature drift | Measured at ACLK ⁽¹⁾ | 1.8 V to 3.6 V | | 0.5 | | %/°C |
| df _{VLO} /dV _{CC} | VLO frequency supply voltage drift | Measured at ACLK ⁽²⁾ | 1.8 V to 3.6 V | | 4 | | %/V |
| | Duty cycle | Measured at ACLK | 1.8 V to 3.6 V | 35 | 50 | 65 | % |

(1) Calculated using the box method: (MAX(-40 to 105°C) – MIN(-40 to 105°C)) / MIN(-40 to 105°C) / (105°C – (-40°C))

(2) Calculated using the box method: (MAX(1.8 to 3.6 V) – MIN(1.8 to 3.6 V)) / MIN(1.8 to 3.6 V) / (3.6 V – 1.8 V)

Internal Reference, Low-Frequency Oscillator (REFO)

over recommended ranges of supply voltage and operating free-air temperature (unless otherwise noted)

| PARAMETER | | TEST CONDITIONS | V _{CC} | MIN | TYP | MAX | UNIT |
|--------------------------------------|-------------------------------------|---------------------------------|-----------------|-----|-------|------|------|
| I _{REFO} | REFO oscillator current consumption | T _A = 25°C | 1.8 V to 3.6 V | | 3 | | μA |
| f _{REFO} | REFO frequency calibrated | Measured at ACLK | 1.8 V to 3.6 V | | 32768 | | Hz |
| | REFO absolute tolerance calibrated | Full temperature range | 1.8 V to 3.6 V | | | ±10 | % |
| | | T _A = 25°C | 3 V | | | ±1.5 | % |
| df _{REFO} /dT | REFO frequency temperature drift | Measured at ACLK ⁽¹⁾ | 1.8 V to 3.6 V | | 0.01 | | %/°C |
| df _{REFO} /dV _{CC} | REFO frequency supply voltage drift | Measured at ACLK ⁽²⁾ | 1.8 V to 3.6 V | | 1.0 | | %/V |
| | Duty cycle | Measured at ACLK | 1.8 V to 3.6 V | 35 | 50 | 65 | % |
| t _{START} | REFO startup time | 40%/60% duty cycle | 1.8 V to 3.6 V | | 25 | | μs |

(1) Calculated using the box method: (MAX(-40 to 105°C) – MIN(-40 to 105°C)) / MIN(-40 to 105°C) / (105°C – (-40°C))

(2) Calculated using the box method: (MAX(1.8 to 3.6 V) – MIN(1.8 to 3.6 V)) / MIN(1.8 to 3.6 V) / (3.6 V – 1.8 V)

DCO Frequency

over recommended ranges of supply voltage and operating free-air temperature (unless otherwise noted)

| PARAMETER | TEST CONDITIONS | MIN | TYP | MAX | UNIT | |
|--------------------|--|--|------|------|-------|------|
| $f_{DCO(0,0)}$ | DCO frequency (0, 0) ⁽¹⁾ | DCORSELx = 0, DCOx = 0, MODx = 0 | 0.07 | 0.20 | MHz | |
| $f_{DCO(0,31)}$ | DCO frequency (0, 31) ⁽¹⁾ | DCORSELx = 0, DCOx = 31, MODx = 0 | 0.70 | 1.70 | MHz | |
| $f_{DCO(1,0)}$ | DCO frequency (1, 0) ⁽¹⁾ | DCORSELx = 1, DCOx = 0, MODx = 0 | 0.15 | 0.36 | MHz | |
| $f_{DCO(1,31)}$ | DCO frequency (1, 31) ⁽¹⁾ | DCORSELx = 1, DCOx = 31, MODx = 0 | 1.47 | 3.55 | MHz | |
| $f_{DCO(2,0)}$ | DCO frequency (2, 0) ⁽¹⁾ | DCORSELx = 2, DCOx = 0, MODx = 0 | 0.32 | 0.76 | MHz | |
| $f_{DCO(2,31)}$ | DCO frequency (2, 31) ⁽¹⁾ | DCORSELx = 2, DCOx = 31, MODx = 0 | 3.17 | 7.38 | MHz | |
| $f_{DCO(3,0)}$ | DCO frequency (3, 0) ⁽¹⁾ | DCORSELx = 3, DCOx = 0, MODx = 0 | 0.64 | 1.53 | MHz | |
| $f_{DCO(3,31)}$ | DCO frequency (3, 31) ⁽¹⁾ | DCORSELx = 3, DCOx = 31, MODx = 0 | 6.07 | 14.5 | MHz | |
| $f_{DCO(4,0)}$ | DCO frequency (4, 0) ⁽¹⁾ | DCORSELx = 4, DCOx = 0, MODx = 0 | 1.3 | 3.2 | MHz | |
| $f_{DCO(4,31)}$ | DCO frequency (4, 31) ⁽¹⁾ | DCORSELx = 4, DCOx = 31, MODx = 0 | 12.3 | 28.2 | MHz | |
| $f_{DCO(5,0)}$ | DCO frequency (5, 0) ⁽¹⁾ | DCORSELx = 5, DCOx = 0, MODx = 0 | 2.5 | 6.0 | MHz | |
| $f_{DCO(5,31)}$ | DCO frequency (5, 31) ⁽¹⁾ | DCORSELx = 5, DCOx = 31, MODx = 0 | 23.7 | 54.3 | MHz | |
| $f_{DCO(6,0)}$ | DCO frequency (6, 0) ⁽¹⁾ | DCORSELx = 6, DCOx = 0, MODx = 0 | 4.6 | 10.7 | MHz | |
| $f_{DCO(6,31)}$ | DCO frequency (6, 31) ⁽¹⁾ | DCORSELx = 6, DCOx = 31, MODx = 0 | 39.0 | 88.0 | MHz | |
| $f_{DCO(7,0)}$ | DCO frequency (7, 0) ⁽¹⁾ | DCORSELx = 7, DCOx = 0, MODx = 0 | 8.5 | 19.6 | MHz | |
| $f_{DCO(7,31)}$ | DCO frequency (7, 31) ⁽¹⁾ | DCORSELx = 7, DCOx = 31, MODx = 0 | 60 | 135 | MHz | |
| $S_{DCORSEL}$ | Frequency step between range DCORSEL and DCORSEL + 1 | $S_{RSEL} = f_{DCO(DCORSEL+1,DCO)} / f_{DCO(DCORSEL,DCO)}$ | 1.2 | 2.3 | ratio | |
| S_{DCO} | Frequency step between tap DCO and DCO + 1 | $S_{DCO} = f_{DCO(DCORSEL,DCO+1)} / f_{DCO(DCORSEL,DCO)}$ | 0.99 | 1.15 | ratio | |
| | Duty cycle | Measured at SMCLK | 35 | 50 | 65 | % |
| df_{DCO}/dT | DCO frequency temperature drift ⁽²⁾ | $f_{DCO} = 1$ MHz | | 0.1 | | %/°C |
| df_{DCO}/dV_{CC} | DCO frequency voltage drift ⁽³⁾ | $f_{DCO} = 1$ MHz | | 1.9 | | %/V |

- (1) When selecting the proper DCO frequency range (DCORSELx), the target DCO frequency, f_{DCO} , should be set to reside within the range of $f_{DCO(n,0),MAX} \leq f_{DCO} \leq f_{DCO(n,31),MIN}$, where $f_{DCO(n,0),MAX}$ represents the maximum frequency specified for the DCO frequency, range n, tap 0 (DCOx = 0) and $f_{DCO(n,31),MIN}$ represents the minimum frequency specified for the DCO frequency, range n, tap 31 (DCOx = 31). This ensures that the target DCO frequency resides within the range selected. It should also be noted that if the actual f_{DCO} frequency for the selected range causes the FLL or the application to select tap 0 or 31, the DCO fault flag is set to report that the selected range is at its minimum or maximum tap setting.
- (2) Calculated using the box method: $(MAX(-40 \text{ to } 105^\circ\text{C}) - MIN(-40 \text{ to } 105^\circ\text{C})) / MIN(-40 \text{ to } 105^\circ\text{C}) / (105^\circ\text{C} - (-40^\circ\text{C}))$
- (3) Calculated using the box method: $(MAX(1.8 \text{ to } 3.6 \text{ V}) - MIN(1.8 \text{ to } 3.6 \text{ V})) / MIN(1.8 \text{ to } 3.6 \text{ V}) / (3.6 \text{ V} - 1.8 \text{ V})$

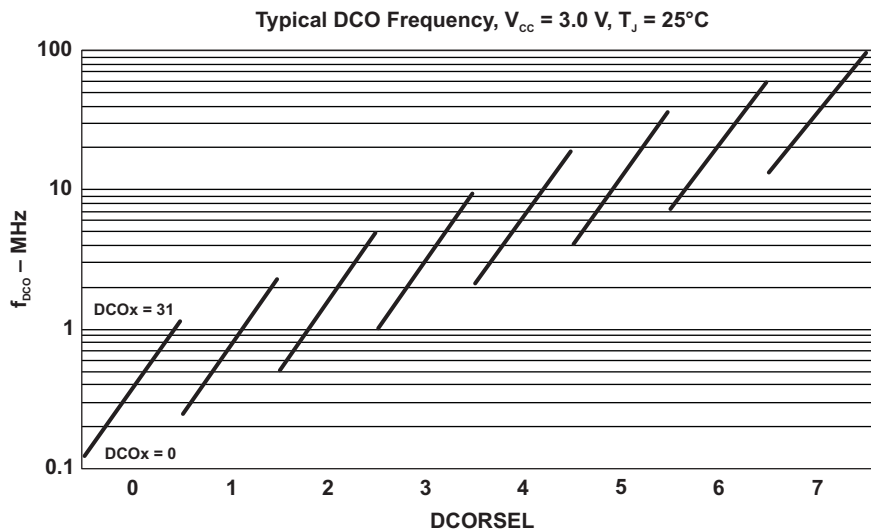

Figure 10. Typical DCO Frequency

PMM, Brown-Out Reset (BOR)

over recommended ranges of supply voltage and operating free-air temperature (unless otherwise noted)

| PARAMETER | | TEST CONDITIONS | MIN | TYP | MAX | UNIT |
|------------------------|--|---------------------------------|------|------|------|------|
| $V_{(DVCC_BOR_IT-)}$ | BOR _H on voltage, DV _{CC} falling level | $ dDV_{CC}/dt < 3 \text{ V/s}$ | | | 1.50 | V |
| $V_{(DVCC_BOR_IT+)}$ | BOR _H off voltage, DV _{CC} rising level | $ dDV_{CC}/dt < 3 \text{ V/s}$ | 0.75 | 1.30 | 1.55 | V |
| $V_{(DVCC_BOR_hys)}$ | BOR _H hysteresis | | 47 | | 263 | mV |
| t_{RESET} | Pulse length required at $\overline{\text{RST/NMI}}$ pin to accept a reset | | 2 | | | μs |

PMM, Core Voltage

over recommended ranges of supply voltage and operating free-air temperature (unless otherwise noted)

| PARAMETER | | TEST CONDITIONS | MIN | TYP | MAX | UNIT |
|-------------------------|--|---|-----|------|-----|------|
| $V_{\text{CORE3(AM)}}$ | Core voltage, active mode, PMMCOREV = 3 | $2.4 \text{ V} \leq DV_{CC} \leq 3.6 \text{ V}$ | | 1.90 | | V |
| $V_{\text{CORE2(AM)}}$ | Core voltage, active mode, PMMCOREV = 2 | $2.2 \text{ V} \leq DV_{CC} \leq 3.6 \text{ V}$ | | 1.80 | | V |
| $V_{\text{CORE1(AM)}}$ | Core voltage, active mode, PMMCOREV = 1 | $2.0 \text{ V} \leq DV_{CC} \leq 3.6 \text{ V}$ | | 1.60 | | V |
| $V_{\text{CORE0(AM)}}$ | Core voltage, active mode, PMMCOREV = 0 | $1.8 \text{ V} \leq DV_{CC} \leq 3.6 \text{ V}$ | | 1.40 | | V |
| $V_{\text{CORE3(LPM)}}$ | Core voltage, low-current mode, PMMCOREV = 3 | $2.4 \text{ V} \leq DV_{CC} \leq 3.6 \text{ V}$ | | 1.94 | | V |
| $V_{\text{CORE2(LPM)}}$ | Core voltage, low-current mode, PMMCOREV = 2 | $2.2 \text{ V} \leq DV_{CC} \leq 3.6 \text{ V}$ | | 1.84 | | V |
| $V_{\text{CORE1(LPM)}}$ | Core voltage, low-current mode, PMMCOREV = 1 | $2.0 \text{ V} \leq DV_{CC} \leq 3.6 \text{ V}$ | | 1.64 | | V |
| $V_{\text{CORE0(LPM)}}$ | Core voltage, low-current mode, PMMCOREV = 0 | $1.8 \text{ V} \leq DV_{CC} \leq 3.6 \text{ V}$ | | 1.44 | | V |

PMM, SVS High Side

over recommended ranges of supply voltage and operating free-air temperature (unless otherwise noted)

| PARAMETER | TEST CONDITIONS | MIN | TYP | MAX | UNIT |
|---|--|------|------|------|------|
| $I_{(SVSH)}$ SVS current consumption | SVSHE = 0, DV _{CC} = 3.6 V | | 0 | | nA |
| | SVSHE = 1, DV _{CC} = 3.6 V, SVSHFP = 0 | | 200 | | nA |
| | SVSHE = 1, DV _{CC} = 3.6 V, SVSHFP = 1 | | 1.5 | | μA |
| $V_{(SVSH_IT-)}$ SVS _H on voltage level ⁽¹⁾ | SVSHE = 1, SVSHRVL = 0 | 1.57 | 1.68 | 1.78 | V |
| | SVSHE = 1, SVSHRVL = 1 | 1.79 | 1.88 | 1.98 | |
| | SVSHE = 1, SVSHRVL = 2 | 1.98 | 2.08 | 2.21 | |
| | SVSHE = 1, SVSHRVL = 3 | 2.10 | 2.18 | 2.31 | |
| $V_{(SVSH_IT+)}$ SVS _H off voltage level ⁽¹⁾ | SVSHE = 1, SVSMHRRL = 0 | 1.62 | 1.74 | 1.85 | V |
| | SVSHE = 1, SVSMHRRL = 1 | 1.88 | 1.94 | 2.07 | |
| | SVSHE = 1, SVSMHRRL = 2 | 2.07 | 2.14 | 2.28 | |
| | SVSHE = 1, SVSMHRRL = 3 | 2.20 | 2.30 | 2.42 | |
| | SVSHE = 1, SVSMHRRL = 4 | 2.32 | 2.40 | 2.55 | |
| | SVSHE = 1, SVSMHRRL = 5 | 2.52 | 2.70 | 2.88 | |
| | SVSHE = 1, SVSMHRRL = 6 | 2.90 | 3.10 | 3.23 | |
| | SVSHE = 1, SVSMHRRL = 7 | 2.90 | 3.10 | 3.23 | |
| $t_{pd(SVSH)}$ SVS _H propagation delay | SVSHE = 1, dV _{DVCC} /dt = 10 mV/μs, SVSHFP = 1 | | 2.5 | | μs |
| | SVSHE = 1, dV _{DVCC} /dt = 1 mV/μs, SVSHFP = 0 | | 20 | | |
| $t_{(SVSH)}$ SVS _H on or off delay time | SVSHE = 0 → 1, dV _{DVCC} /dt = 10 mV/μs, SVSHFP = 1 | | 12.5 | | μs |
| | SVSHE = 0 → 1, dV _{DVCC} /dt = 1 mV/μs, SVSHFP = 0 | | 100 | | |
| dV _{DVCC} /dt DV _{CC} rise time | | 0 | | 1000 | V/s |

(1) The SVS_H settings available depend on the V_{CORE} (PMMCOREV_x) setting. See the *Power Management Module and Supply Voltage Supervisor* chapter in the *MSP430x5xx and MSP430x6xx Family User's Guide (SLAU208)* on recommended settings and usage.

PMM, SVM High Side

over recommended ranges of supply voltage and operating free-air temperature (unless otherwise noted)

| PARAMETER | TEST CONDITIONS | MIN | TYP | MAX | UNIT |
|--|--|------|------|------|------|
| $I_{(SVMH)}$ SVM _H current consumption | SVMHE = 0, DV _{CC} = 3.6 V | | 0 | | nA |
| | SVMHE = 1, DV _{CC} = 3.6 V, SVMHFP = 0 | | 200 | | nA |
| | SVMHE = 1, DV _{CC} = 3.6 V, SVMHFP = 1 | | 1.5 | | μA |
| $V_{(SVMH)}$ SVM _H on or off voltage level ⁽¹⁾ | SVMHE = 1, SVSMHRRRL = 0 | 1.62 | 1.74 | 1.85 | V |
| | SVMHE = 1, SVSMHRRRL = 1 | 1.88 | 1.94 | 2.07 | |
| | SVMHE = 1, SVSMHRRRL = 2 | 2.07 | 2.14 | 2.28 | |
| | SVMHE = 1, SVSMHRRRL = 3 | 2.20 | 2.30 | 2.42 | |
| | SVMHE = 1, SVSMHRRRL = 4 | 2.32 | 2.40 | 2.55 | |
| | SVMHE = 1, SVSMHRRRL = 5 | 2.52 | 2.70 | 2.88 | |
| | SVMHE = 1, SVSMHRRRL = 6 | 2.90 | 3.10 | 3.23 | |
| | SVMHE = 1, SVSMHRRRL = 7 | 2.90 | 3.10 | 3.23 | |
| $t_{pd(SVMH)}$ SVM _H propagation delay | SVMHE = 1, dV _{DVCC} /dt = 10 mV/μs, SVMHFP = 1 | | 2.5 | | μs |
| | SVMHE = 1, dV _{DVCC} /dt = 1 mV/μs, SVMHFP = 0 | | 20 | | |
| $t_{(SVMH)}$ SVM _H on or off delay time | SVMHE = 0 → 1, dV _{DVCC} /dt = 10 mV/μs, SVMHFP = 1 | | 12.5 | | μs |
| | SVMHE = 0 → 1, dV _{DVCC} /dt = 1 mV/μs, SVMHFP = 0 | | 100 | | |

(1) The SVM_H settings available depend on the V_{CORE} (PMMCOREVx) setting. See the *Power Management Module and Supply Voltage Supervisor* chapter in the *MSP430x5xx and MSP430x6xx Family User's Guide (SLAU208)* on recommended settings and usage.

PMM, SVS Low Side

over recommended ranges of supply voltage and operating free-air temperature (unless otherwise noted)

| PARAMETER | TEST CONDITIONS | MIN | TYP | MAX | UNIT |
|--|---|-----|------|-----|------|
| $I_{(SVSL)}$ SVS _L current consumption | SVSLE = 0, PMMCOREV = 2 | | 0 | | nA |
| | SVSLE = 1, PMMCOREV = 2, SVSLFPP = 0 | | 200 | | nA |
| | SVSLE = 1, PMMCOREV = 2, SVSLFPP = 1 | | 1.5 | | μA |
| $t_{pd(SVSL)}$ SVS _L propagation delay | SVSLE = 1, dV _{CORE} /dt = 10 mV/μs, SVSLFPP = 1 | | 2.5 | | μs |
| | SVSLE = 1, dV _{CORE} /dt = 1 mV/μs, SVSLFPP = 0 | | 20 | | |
| $t_{(SVSL)}$ SVS _L on or off delay time | SVSLE = 0 → 1, dV _{CORE} /dt = 10 mV/μs, SVSLFPP = 1 | | 12.5 | | μs |
| | SVSLE = 0 → 1, dV _{CORE} /dt = 1 mV/μs, SVSLFPP = 0 | | 100 | | |

PMM, SVM Low Side

over recommended ranges of supply voltage and operating free-air temperature (unless otherwise noted)

| PARAMETER | TEST CONDITIONS | MIN | TYP | MAX | UNIT |
|--|---|-----|------|-----|------|
| $I_{(SVML)}$ SVM _L current consumption | SVMLE = 0, PMMCOREV = 2 | | 0 | | nA |
| | SVMLE = 1, PMMCOREV = 2, SVMLFPP = 0 | | 200 | | nA |
| | SVMLE = 1, PMMCOREV = 2, SVMLFPP = 1 | | 1.5 | | μA |
| $t_{pd(SVML)}$ SVM _L propagation delay | SVMLE = 1, dV _{CORE} /dt = 10 mV/μs, SVMLFPP = 1 | | 2.5 | | μs |
| | SVMLE = 1, dV _{CORE} /dt = 1 mV/μs, SVMLFPP = 0 | | 20 | | |
| $t_{(SVML)}$ SVM _L on or off delay time | SVMLE = 0 → 1, dV _{CORE} /dt = 10 mV/μs, SVMLFPP = 1 | | 12.5 | | μs |
| | SVMLE = 0 → 1, dV _{CORE} /dt = 1 mV/μs, SVMLFPP = 0 | | 100 | | |

Wake-Up From Low Power Modes and Reset

over recommended ranges of supply voltage and operating free-air temperature (unless otherwise noted)

| PARAMETER | | TEST CONDITIONS | MIN | TYP | MAX | UNIT |
|----------------------------|---|---|---------------------------------------|-----|-----|------|
| t _{WAKE-UP-FAST} | Wake-up time from LPM2, LPM3, or LPM4 to active mode ⁽¹⁾ | PMMCOREV = SVSMLRRL = n (where n = 0, 1, 2, or 3), SVSLFP = 1 | f _{MCLK} ≥ 4.0 MHz | 3.5 | 7.5 | μs |
| | | | 1.0 MHz < f _{MCLK} < 4.0 MHz | 4.5 | 9 | |
| t _{WAKE-UP-SLOW} | Wake-up time from LPM2, LPM3 or LPM4 to active mode ⁽²⁾ | PMMCOREV = SVSMLRRL = n (where n = 0, 1, 2, or 3), SVSLFP = 0 | | 150 | 175 | μs |
| t _{WAKE-UP-LPM5} | Wake-up time from LPM4.5 to active mode ⁽³⁾ | | | 2 | 3 | ms |
| t _{WAKE-UP-RESET} | Wake-up time from \overline{RST} or BOR event to active mode ⁽³⁾ | | | 2 | 3 | ms |

- (1) This value represents the time from the wakeup event to the first active edge of MCLK. The wakeup time depends on the performance mode of the low side supervisor (SVS_L) and low side monitor (SVM_L). Fastest wakeup times are possible with SVS_L and SVM_L in full performance mode or disabled when operating in AM, LPM0, and LPM1. Various options are available for SVS_L and SVM_L while operating in LPM2, LPM3, and LPM4. See the *Power Management Module and Supply Voltage Supervisor* chapter in the *MSP430x5xx and MSP430x6xx Family User's Guide (SLAU208)*.
- (2) This value represents the time from the wakeup event to the first active edge of MCLK. The wakeup time depends on the performance mode of the low side supervisor (SVS_L) and low side monitor (SVM_L). In this case, the SVS_L and SVM_L are in normal mode (low current) mode when operating in AM, LPM0, and LPM1. Various options are available for SVS_L and SVM_L while operating in LPM2, LPM3, and LPM4. See the *Power Management Module and Supply Voltage Supervisor* chapter in the *MSP430x5xx and MSP430x6xx Family User's Guide (SLAU208)*.
- (3) This value represents the time from the wakeup event to the reset vector execution.

Timer_A

over recommended ranges of supply voltage and operating free-air temperature (unless otherwise noted)

| PARAMETER | | TEST CONDITIONS | V _{CC} | MIN | TYP | MAX | UNIT |
|---------------------|-------------------------------|--|-----------------|-----|-----|-----|------|
| f _{TA} | Timer_A input clock frequency | Internal: SMCLK, ACLK, External: TACLK, Duty cycle = 50% ± 10% | 1.8 V, 3 V | | | 25 | MHz |
| t _{TA,cap} | Timer_A capture timing | All capture inputs. Minimum pulse width required for capture. | 1.8 V, 3 V | 20 | | | ns |

Timer_B

over recommended ranges of supply voltage and operating free-air temperature (unless otherwise noted)

| PARAMETER | | TEST CONDITIONS | V _{CC} | MIN | TYP | MAX | UNIT |
|---------------------|-------------------------------|--|-----------------|-----|-----|-----|------|
| f _{TB} | Timer_B input clock frequency | Internal: SMCLK, ACLK, External: TBCLK, Duty cycle = 50% ± 10% | 1.8 V, 3 V | | | 25 | MHz |
| t _{TB,cap} | Timer_B capture timing | All capture inputs, Minimum pulse width required for capture. | 1.8 V, 3 V | 20 | | | ns |

USCI (UART Mode) Recommended Operating Conditions

| PARAMETER | | CONDITIONS | V _{CC} | MIN | TYP | MAX | UNIT |
|---------------------|---|---|-----------------|-----|-----|---------------------|------|
| f _{USCI} | USCI input clock frequency | Internal: SMCLK, ACLK, External: UCLK, Duty cycle = 50% ± 10% | | | | f _{SYSTEM} | MHz |
| f _{BITCLK} | BITCLK clock frequency (equals baud rate in MBaud) | | | | | 1 | MHz |

USCI (UART Mode)

over recommended ranges of supply voltage and operating free-air temperature (unless otherwise noted)

| PARAMETER | | TEST CONDITIONS | V _{CC} | MIN | TYP | MAX | UNIT |
|----------------|---|-----------------|-----------------|-----|-----|-----|------|
| t _r | UART receive deglitch time ⁽¹⁾ | | 2.2 V | 50 | | 600 | ns |
| | | | 3 V | 50 | | 600 | |

- (1) Pulses on the UART receive input (UCxRX) shorter than the UART receive deglitch time are suppressed. To ensure that pulses are correctly recognized their width should exceed the maximum specification of the deglitch time.

USCI (SPI Master Mode) Recommended Operating Conditions

| PARAMETER | | CONDITIONS | V _{CC} | MIN | TYP | MAX | UNIT |
|-------------------|----------------------------|--|-----------------|-----|-----|---------------------|------|
| f _{USCI} | USCI input clock frequency | Internal: SMCLK, ACLK, Duty cycle = 50% ± 10% | | | | f _{SYSTEM} | MHz |

USCI (SPI Master Mode)

over recommended ranges of supply voltage and operating free-air temperature (unless otherwise noted)

(see Note ⁽¹⁾, [Figure 11](#) and [Figure 12](#))

| PARAMETER | | TEST CONDITIONS | V _{CC} | MIN | TYP | MAX | UNIT |
|-----------------------|--|--|-----------------|-----|-----|---------------------|------|
| f _{USCI} | USCI input clock frequency | SMCLK, ACLK Duty cycle = 50% ± 10% | | | | f _{SYSTEM} | MHz |
| t _{SU,MI} | SOMI input data setup time | PMMCOREV = 0 | 1.8 V | 55 | | | ns |
| | | | 3 V | 38 | | | |
| | | PMMCOREV = 3 | 2.4 V | 30 | | | ns |
| | | | 3 V | 25 | | | |
| t _{HD,MI} | SOMI input data hold time | PMMCOREV = 0 | 1.8 V | 0 | | | ns |
| | | | 3 V | 0 | | | |
| | | PMMCOREV = 3 | 2.4 V | 0 | | | ns |
| | | | 3 V | 0 | | | |
| t _{VALID,MO} | SIMO output data valid time ⁽²⁾ | UCLK edge to SIMO valid, C _L = 20 pF, PMMCOREV = 0 | 1.8 V | | | 20 | ns |
| | | | 3 V | | | 18 | |
| | | UCLK edge to SIMO valid, C _L = 20 pF, PMMCOREV = 3 | 2.4 V | | | 16 | ns |
| | | | 3 V | | | 15 | |
| t _{HD,MO} | SIMO output data hold time ⁽³⁾ | C _L = 20 pF, PMMCOREV = 0 | 1.8 V | -10 | | | ns |
| | | | 3 V | -8 | | | |
| | | C _L = 20 pF, PMMCOREV = 3 | 2.4 V | -10 | | | ns |
| | | | 3 V | -8 | | | |

- (1) $f_{UCxCLK} = 1/2t_{LO/HI}$ with $t_{LO/HI} \geq \max(t_{VALID,MO(USCI)} + t_{SU,SI(Slave)}, t_{SU,MI(USCI)} + t_{VALID,SO(Slave)})$.
For the slave's parameters $t_{SU,SI(Slave)}$ and $t_{VALID,SO(Slave)}$ see the SPI parameters of the attached slave.
- (2) Specifies the time to drive the next valid data to the SIMO output after the output changing UCLK clock edge. See the timing diagrams in [Figure 11](#) and [Figure 12](#).
- (3) Specifies how long data on the SIMO output is valid after the output changing UCLK clock edge. Negative values indicate that the data on the SIMO output can become invalid before the output changing clock edge observed on UCLK. See the timing diagrams in [Figure 11](#) and [Figure 12](#).

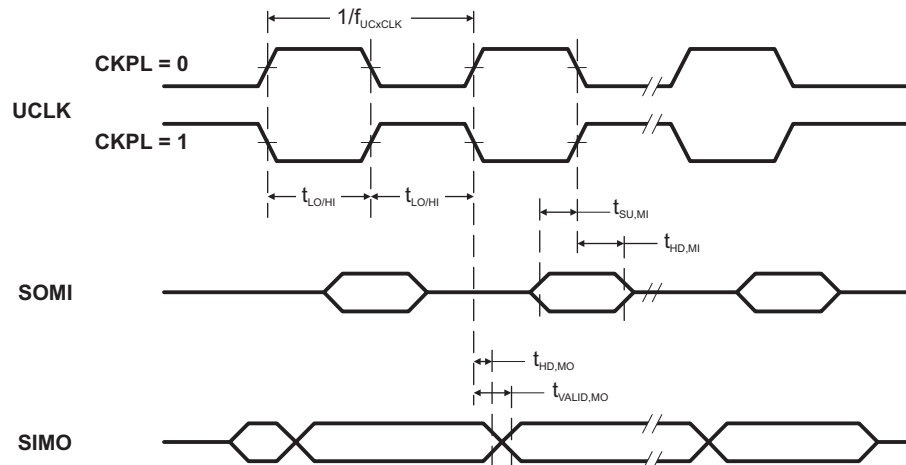

Figure 11. SPI Master Mode, CKPH = 0

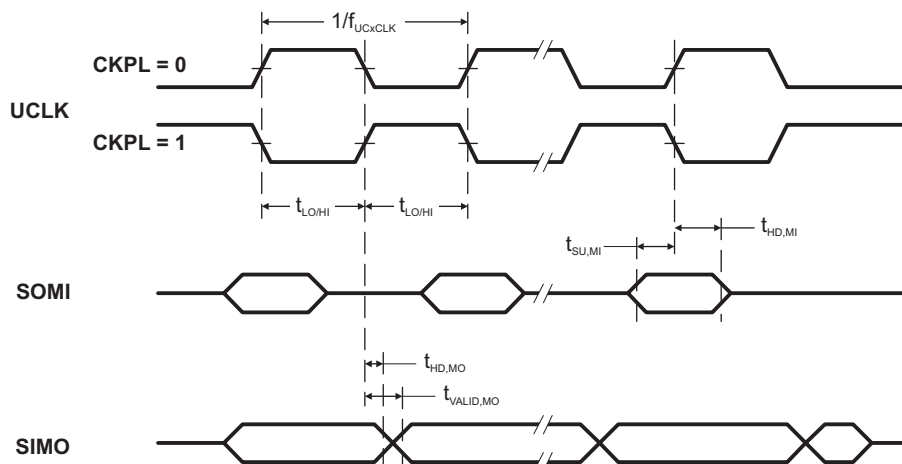

Figure 12. SPI Master Mode, CKPH = 1

USCI (SPI Slave Mode)

over recommended ranges of supply voltage and operating free-air temperature (unless otherwise noted)
(see Note ⁽¹⁾, [Figure 13](#) and [Figure 14](#))

| PARAMETER | | TEST CONDITIONS | V _{CC} | MIN | TYP | MAX | UNIT |
|-----------------------|---|--|-----------------|-----|-----|-----|------|
| t _{STE,LEAD} | STE lead time, STE low to clock | PMMCOREV = 0 | 1.8 V | 11 | | | ns |
| | | | 3 V | 8 | | | |
| | | PMMCOREV = 3 | 2.4 V | 7 | | | ns |
| | | | 3 V | 6 | | | |
| t _{STE,LAG} | STE lag time, Last clock to STE high | PMMCOREV = 0 | 1.8 V | 3 | | | ns |
| | | | 3 V | 3 | | | |
| | | PMMCOREV = 3 | 2.4 V | 3 | | | ns |
| | | | 3 V | 3 | | | |
| t _{STE,ACC} | STE access time, STE low to SOMI data out | PMMCOREV = 0 | 1.8 V | | | 66 | ns |
| | | | 3 V | | | 50 | |
| | | PMMCOREV = 3 | 2.4 V | | | 36 | ns |
| | | | 3 V | | | 30 | |
| t _{STE,DIS} | STE disable time, STE high to SOMI high impedance | PMMCOREV = 0 | 1.8 V | | | 30 | ns |
| | | | 3 V | | | 23 | |
| | | PMMCOREV = 3 | 2.4 V | | | 16 | ns |
| | | | 3 V | | | 13 | |
| t _{SU,SI} | SIMO input data setup time | PMMCOREV = 0 | 1.8 V | 5 | | | ns |
| | | | 3 V | 5 | | | |
| | | PMMCOREV = 3 | 2.4 V | 2 | | | ns |
| | | | 3 V | 2 | | | |
| t _{HD,SI} | SIMO input data hold time | PMMCOREV = 0 | 1.8 V | 5 | | | ns |
| | | | 3 V | 5 | | | |
| | | PMMCOREV = 3 | 2.4 V | 5 | | | ns |
| | | | 3 V | 5 | | | |
| t _{VALID,SO} | SOMI output data valid time ⁽²⁾ | UCLK edge to SOMI valid, C _L = 20 pF PMMCOREV = 0 | 1.8 V | | | 76 | ns |
| | | | 3 V | | | 60 | |
| | | UCLK edge to SOMI valid, C _L = 20 pF PMMCOREV = 3 | 2.4 V | | | 44 | ns |
| | | | 3 V | | | 40 | |
| t _{HD,SO} | SOMI output data hold time ⁽³⁾ | C _L = 20 pF PMMCOREV = 0 | 1.8 V | 18 | | | ns |
| | | | 3 V | 12 | | | |
| | | C _L = 20 pF PMMCOREV = 3 | 2.4 V | 10 | | | ns |
| | | | 3 V | 8 | | | |

- (1) $f_{UCXCLK} = 1/2t_{LO/HI}$ with $t_{LO/HI} \geq \max(t_{VALID,MO(Master)} + t_{SU,SI(USCI)}, t_{SU,MI(Master)} + t_{VALID,SO(USCI)})$.
For the master's parameters $t_{SU,MI(Master)}$ and $t_{VALID,MO(Master)}$ see the SPI parameters of the attached slave.
- (2) Specifies the time to drive the next valid data to the SOMI output after the output changing UCLK clock edge. See the timing diagrams in [Figure 11](#) and [Figure 12](#).
- (3) Specifies how long data on the SOMI output is valid after the output changing UCLK clock edge. See the timing diagrams in [Figure 11](#) and [Figure 12](#).

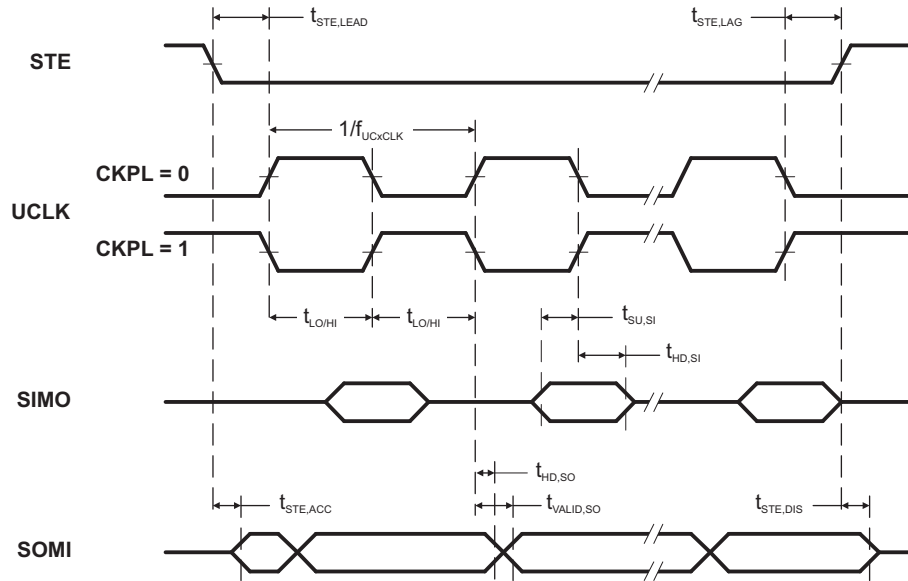

Figure 13. SPI Slave Mode, CKPH = 0

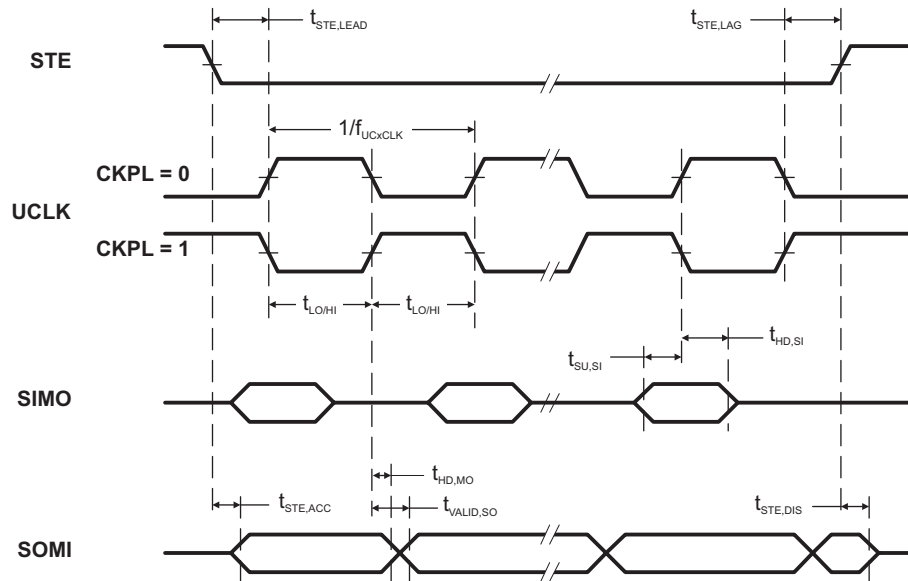

Figure 14. SPI Slave Mode, CKPH = 1

USCI (I2C Mode)

over recommended ranges of supply voltage and operating free-air temperature (unless otherwise noted) (see [Figure 15](#))

| PARAMETER | TEST CONDITIONS | V _{CC} | MIN | TYP | MAX | UNIT |
|---------------------|--|--|------------|------------|---------------------|------|
| f _{USCI} | USCI input clock frequency | | | | f _{SYSTEM} | MHz |
| f _{SCL} | SCL clock frequency | 2.2 V, 3 V | 0 | | 400 | kHz |
| t _{HD,STA} | Hold time (repeated) START | f _{SCL} ≤ 100 kHz f _{SCL} > 100 kHz | 2.2 V, 3 V | 4.0 0.6 | | μs |
| t _{SU,STA} | Setup time for a repeated START | f _{SCL} ≤ 100 kHz f _{SCL} > 100 kHz | 2.2 V, 3 V | 4.7 0.6 | | μs |
| t _{HD,DAT} | Data hold time | | 2.2 V, 3 V | 0 | | ns |
| t _{SU,DAT} | Data setup time | | 2.2 V, 3 V | 250 | | ns |
| t _{SU,STO} | Setup time for STOP | f _{SCL} ≤ 100 kHz f _{SCL} > 100 kHz | 2.2 V, 3 V | 4.0 0.6 | | μs |
| t _{SP} | Pulse width of spikes suppressed by input filter | 2.2 V 3 V | 50 50 | | 600 600 | ns |

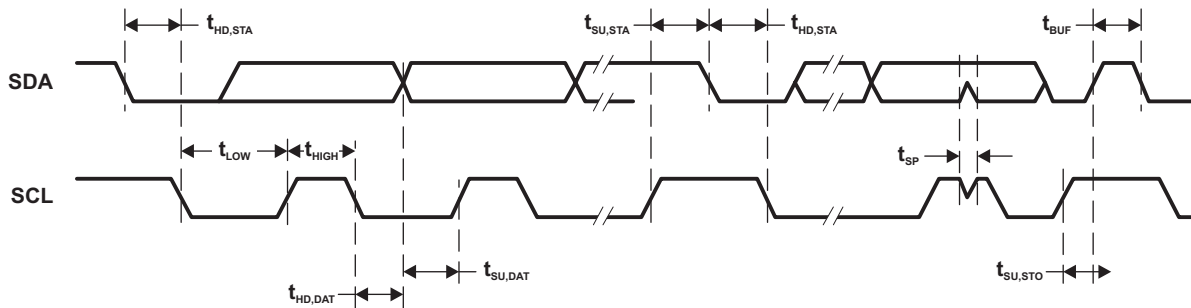

Figure 15. I2C Mode Timing

12-Bit ADC, Power Supply and Input Range Conditions

over recommended ranges of supply voltage and operating free-air temperature (unless otherwise noted)⁽¹⁾

| PARAMETER | | TEST CONDITIONS | V _{CC} | MIN | TYP | MAX | UNIT |
|----------------------|--|---|-----------------|-----|-----|------------------|------|
| AV _{CC} | Analog supply voltage | AVCC and DVCC are connected together, AVSS and DVSS are connected together, V _(AVSS) = V _(DVSS) = 0 V | | 2.2 | | 3.6 | V |
| V _(Ax) | Analog input voltage range ⁽²⁾ | All ADC12 analog input pins Ax | | 0 | | AV _{CC} | V |
| I _{ADC12_A} | Operating supply current into AVCC terminal ⁽³⁾ | f _{ADC12CLK} = 5.0 MHz ⁽⁴⁾ | 2.2 V | | 125 | 160 | μA |
| | | | 3 V | | 150 | 225 | |
| C _I | Input capacitance | Only one terminal Ax can be selected at one time | 2.2 V | | 20 | | pF |
| R _I | Input MUX ON resistance | 0 V ≤ V _{Ax} ≤ AVCC | | | 200 | | Ω |

(1) The leakage current is specified by the digital I/O input leakage.

(2) The analog input voltage range must be within the selected reference voltage range V_{R+} to V_{R-} for valid conversion results. If the reference voltage is supplied by an external source or if the internal reference voltage is used and REFOUT = 1, then decoupling capacitors are required (see [REF, External Reference](#) and [REF, Built-In Reference](#)).

(3) The internal reference supply current is not included in current consumption parameter I_{ADC12_A}.

(4) ADC12ON = 1, REFON = 0, SHT0 = 0, SHT1 = 0, ADC12DIV = 0

12-Bit ADC, Timing Parameters

over recommended ranges of supply voltage and operating free-air temperature (unless otherwise noted)

| PARAMETER | | TEST CONDITIONS | V _{CC} | MIN | TYP | MAX | UNIT |
|-----------------------|--|---|-----------------|------|-----|-----|------|
| f _{ADC12CLK} | ADC conversion clock | For specified performance of ADC12 linearity parameters using an external reference voltage or AVCC as reference ⁽¹⁾ | 2.2 V, 3 V | 0.45 | 4.8 | 5.0 | MHz |
| | | For specified performance of ADC12 linearity parameters using the internal reference ⁽²⁾ | | 0.45 | 2.4 | 4.0 | |
| | | For specified performance of ADC12 linearity parameters using the internal reference ⁽³⁾ | | 0.45 | 2.4 | 2.7 | |
| f _{ADC12OSC} | Internal ADC12 oscillator ⁽⁴⁾ | ADC12DIV = 0, f _{ADC12CLK} = f _{ADC12OSC} | 2.2 V, 3 V | 4.2 | 4.8 | 5.4 | MHz |
| t _{CONVERT} | Conversion time | REFON = 0, Internal oscillator, ADC12OSC used for ADC conversion clock | 2.2 V, 3 V | 2.4 | | 3.1 | μs |
| | | External f _{ADC12CLK} from ACLK, MCLK, or SMCLK, ADC12SSEL ≠ 0 | | | (5) | | |
| t _{Sample} | Sampling time | R _S = 400 Ω, R _I = 1000 Ω, C _I = 20 pF, T = [R _S + R _I] × C _I ⁽⁶⁾ | 2.2 V, 3 V | 1000 | | | ns |

(1) REFOUT = 0, external reference voltage: SREF2 = 0, SREF1 = 1, SREF0 = 0. AVCC as reference voltage: SREF2 = 0, SREF1 = 0, SREF0 = 0. The specified performance of the ADC12 linearity is ensured when using the ADC12OSC. For other clock sources, the specified performance of the ADC12 linearity is ensured with f_{ADC12CLK} maximum of 5.0 MHz.

(2) SREF2 = 0, SREF1 = 1, SREF0 = 0, ADC12SR = 0, REFOUT = 1

(3) SREF2 = 0, SREF1 = 1, SREF0 = 0, ADC12SR = 0, REFOUT = 0. The specified performance of the ADC12 linearity is ensured when using the ADC12OSC divided by 2.

(4) The ADC12OSC is sourced directly from MODOSC inside the UCS.

(5) 13 × ADC12DIV × 1/f_{ADC12CLK}

(6) Approximately ten Tau (τ) are needed to get an error of less than ±0.5 LSB:

$$t_{\text{Sample}} = \ln(2^{n+1}) \times (R_S + R_I) \times C_I + 800 \text{ ns, where } n = \text{ADC resolution} = 12, R_S = \text{external source resistance}$$

12-Bit ADC, Linearity Parameters Using an External Reference Voltage or AVCC as Reference Voltage

over recommended ranges of supply voltage and operating free-air temperature (unless otherwise noted)

| PARAMETER | | TEST CONDITIONS | V _{CC} | MIN | TYP | MAX | UNIT |
|----------------|---|--------------------------------------|-----------------|------|-----|-----|------|
| E _I | Integral linearity error ⁽¹⁾ | 1.4 V ≤ dVREF ≤ 1.6 V ⁽²⁾ | 3 V | ±2.0 | | | LSB |
| | | 1.6 V < dVREF ⁽²⁾ | | ±1.7 | | | |
| E _D | Differential linearity error ⁽¹⁾ | See ⁽²⁾ | 3 V | ±1.0 | | | LSB |
| E _O | Offset error ⁽³⁾ | dVREF ≤ 2.2 V ⁽²⁾ | 3 V | ±1.0 | | | LSB |
| | | dVREF > 2.2 V ⁽²⁾ | 3 V | ±1.0 | | | |
| E _G | Gain error ⁽³⁾ | See ⁽²⁾ | 3 V | ±1.0 | | | LSB |
| E _T | Total unadjusted error | dVREF ≤ 2.2 V ⁽²⁾ | 3 V | ±1.4 | | | LSB |
| | | dVREF > 2.2 V ⁽²⁾ | 3 V | ±1.4 | | | |

(1) Parameters are derived using the histogram method.

(2) The external reference voltage is selected by: SREF2 = 0 or 1, SREF1 = 1, SREF0 = 0. dVREF = V_{R+} - V_{R-}, V_{R+} < AVCC, V_{R-} > AVSS. Unless otherwise mentioned, dVREF > 1.5 V. Impedance of the external reference voltage R < 100 Ω and two decoupling capacitors, 10 μF and 100 nF, should be connected to VREF+/VREF- to decouple the dynamic current. See also the *MSP430x5xx and MSP430x6xx Family User's Guide (SLAU208)*.

(3) Parameters are derived using a best fit curve.

12-Bit ADC, Linearity Parameters Using the Internal Reference Voltage

over recommended ranges of supply voltage and operating free-air temperature (unless otherwise noted)

| PARAMETER | TEST CONDITIONS ⁽¹⁾ | | V _{CC} | MIN | TYP | MAX | UNIT |
|----------------|---|-------------------------|-----------------|----------------------|------|-----|------|
| E _I | Integral linearity error ⁽²⁾ | ADC12SR = 0, REFOUT = 1 | 3 V | ±2.5 | | | LSB |
| | | ADC12SR = 0, REFOUT = 0 | | ±4 | | | |
| E _D | Differential linearity error ⁽²⁾ | ADC12SR = 0, REFOUT = 1 | 3 V | -1.0 | +2.0 | | LSB |
| | | ADC12SR = 0, REFOUT = 1 | | -1.0 | +1.5 | | |
| | | ADC12SR = 0, REFOUT = 0 | | -1.0 | +2.9 | | |
| E _O | Offset error ⁽³⁾ | ADC12SR = 0, REFOUT = 1 | 3 V | ±1.0 | | | LSB |
| | | ADC12SR = 0, REFOUT = 0 | | ±1.0 | | | |
| E _G | Gain error ⁽³⁾ | ADC12SR = 0, REFOUT = 1 | 3 V | ±1.0 | | | LSB |
| | | ADC12SR = 0, REFOUT = 0 | | ±1.5% ⁽⁴⁾ | | | VREF |
| E _T | Total unadjusted error | ADC12SR = 0, REFOUT = 1 | 3 V | ±1.4 | | | LSB |
| | | ADC12SR = 0, REFOUT = 0 | | ±1.5% ⁽⁴⁾ | | | VREF |

(1) The internal reference voltage is selected by: SREF2 = 0 or 1, SREF1 = 1, SREF0 = 1. dVREF = V_{R+} - V_{R-}.

(2) Parameters are derived using the histogram method.

(3) Parameters are derived using a best fit curve.

(4) The gain error and total unadjusted error are dominated by the accuracy of the integrated reference module absolute accuracy. In this mode the reference voltage used by the ADC12_A is not available on a pin.

12-Bit ADC, Temperature Sensor and Built-In V_{MID} ⁽¹⁾

over recommended ranges of supply voltage and operating free-air temperature (unless otherwise noted)

| PARAMETER | | TEST CONDITIONS | V_{CC} | MIN | TYP | MAX | UNIT |
|----------------------|---|---|----------|--------------|-------------|--------------|----------------------|
| V_{SENSOR} | See ⁽²⁾ | ADC12ON = 1, INCH = 0Ah, $T_A = 0^\circ\text{C}$ | 2.2 V | 680 | | | mV |
| | | | 3 V | 680 | | | |
| TC_{SENSOR} | | ADC12ON = 1, INCH = 0Ah | 2.2 V | 2.25 | | | mV/ $^\circ\text{C}$ |
| | | | 3 V | 2.25 | | | |
| $t_{SENSOR(sample)}$ | Sample time required if channel 10 is selected ⁽³⁾ | ADC12ON = 1, INCH = 0Ah, Error of conversion result ≤ 1 LSB | 3 V | 100 | | | μs |
| V_{MID} | AV _{CC} divider at channel 11, V _{AVCC} factor | ADC12ON = 1, INCH = 0Bh | | 0.46 AVCC | 0.5 AVCC | 0.54 AVCC | V |
| | AV _{CC} divider at channel 11 | ADC12ON = 1, INCH = 0Bh | 2.2 V | 1.012 | 1.1 | 1.188 | V |
| | | | 3 V | 1.38 | 1.5 | 1.62 | |
| $t_{VMID(sample)}$ | Sample time required if channel 11 is selected ⁽⁴⁾ | ADC12ON = 1, INCH = 0Bh, Error of conversion result ≤ 1 LSB | 3 V | 1000 | | | ns |

- (1) The temperature sensor is provided by the REF module. See the REF module parametric, I_{REF+} , regarding the current consumption of the temperature sensor.
- (2) The temperature sensor offset can be significant. A single-point calibration is recommended to minimize the offset error of the built-in temperature sensor. The TLV structure contains calibration values for $30^\circ\text{C} \pm 3^\circ\text{C}$ and $105^\circ\text{C} \pm 3^\circ\text{C}$ for each of the available reference voltage levels. The sensor voltage can be computed as $V_{SENSE} = TC_{SENSOR} * (\text{Temperature}, ^\circ\text{C}) + V_{SENSOR}$, where TC_{SENSOR} and V_{SENSOR} can be computed from the calibration values for higher accuracy. See also the *MSP430x5xx and MSP430x6xx Family User's Guide (SLAU208)*.
- (3) The typical equivalent impedance of the sensor is 51 k Ω . The sample time required includes the sensor-on time $t_{SENSOR(on)}$.
- (4) The on-time $t_{VMID(on)}$ is included in the sampling time $t_{VMID(sample)}$; no additional on time is needed.

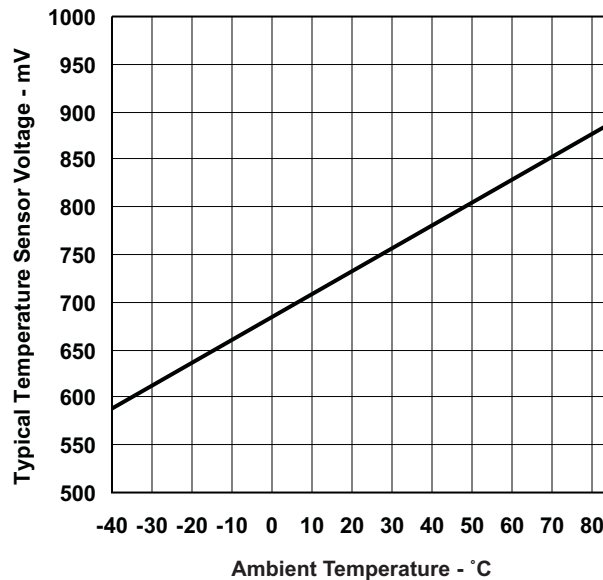

Figure 16. Typical Temperature Sensor Voltage

REF, External Reference

over recommended ranges of supply voltage and operating free-air temperature (unless otherwise noted)⁽¹⁾

| PARAMETER | | TEST CONDITIONS | V _{CC} | MIN | TYP | MAX | UNIT |
|---|---|--|-----------------|------|-----|------|------|
| V _{eREF+} | Positive external reference voltage input | V _{eREF+} > V _{REF-} /V _{eREF-} ⁽²⁾ | | 1.4 | | AVCC | V |
| V _{REF-} /V _{eREF-} | Negative external reference voltage input | V _{eREF+} > V _{REF-} /V _{eREF-} ⁽³⁾ | | 0 | | 1.2 | V |
| (V _{eREF+} – V _{REF-} /V _{eREF-}) | Differential external reference voltage input | V _{eREF+} > V _{REF-} /V _{eREF-} ⁽⁴⁾ | | 1.4 | | AVCC | V |
| I _{VeREF+} , I _{VREF-/VeREF-} | Static input current | 1.4 V ≤ V _{eREF+} ≤ V _{AVCC} , V _{eREF-} = 0 V, f _{ADC12CLK} = 5 MHz, ADC12SHT _x = 1h, Conversion rate 200 ksp/s | 2.2 V, 3 V | | ±26 | | μA |
| | | 1.4 V ≤ V _{eREF+} ≤ V _{AVCC} , V _{eREF-} = 0 V, f _{ADC12CLK} = 5 MHz, ADC12SHT _x = 8h, Conversion rate 20 ksp/s | 2.2 V, 3 V | -1.1 | | 1.1 | μA |
| C _{VREF+/-} | Capacitance at V _{REF+/-} terminal | See ⁽⁵⁾ | | | 10 | | μF |

- (1) The external reference is used during ADC conversion to charge and discharge the capacitance array. The input capacitance, C_i, is also the dynamic load for an external reference during conversion. The dynamic impedance of the reference supply should follow the recommendations on analog-source impedance to allow the charge to settle for 12-bit accuracy.
- (2) The accuracy limits the minimum positive external reference voltage. Lower reference voltage levels may be applied with reduced accuracy requirements.
- (3) The accuracy limits the maximum negative external reference voltage. Higher reference voltage levels may be applied with reduced accuracy requirements.
- (4) The accuracy limits minimum external differential reference voltage. Lower differential reference voltage levels may be applied with reduced accuracy requirements.
- (5) Two decoupling capacitors, 10μF and 100nF, should be connected to VREF to decouple the dynamic current required for an external reference source if it is used for the ADC12_A. See also the *MSP430x5xx and MSP430x6xx Family User's Guide (SLAU208)*.

REF, Built-In Reference

over recommended ranges of supply voltage and operating free-air temperature (unless otherwise noted)⁽¹⁾

| PARAMETER | TEST CONDITIONS | V _{CC} | MIN | TYP | MAX | UNIT |
|--|--|-----------------|------|------|------|--------|
| V _{REF+} Positive built-in reference voltage output | REFVSEL = {2} for 2.5 V, REFON = REFOUT = 1, I _{VREF+} = 0 A | 3 V | 2.39 | 2.50 | 2.6 | V |
| | REFVSEL = {1} for 2.0 V, REFON = REFOUT = 1, I _{VREF+} = 0 A | 3 V | 1.9 | 1.98 | 2.06 | |
| | REFVSEL = {0} for 1.5 V, REFON = REFOUT = 1, I _{VREF+} = 0 A | 2.2 V, 3 V | 1.42 | 1.49 | 1.55 | |
| AV _{CC(min)} AVCC minimum voltage, Positive built-in reference active | REFVSEL = {0} for 1.5 V | | 2.2 | | | V |
| | REFVSEL = {1} for 2.0 V | | 2.3 | | | |
| | REFVSEL = {2} for 2.5 V | | 2.8 | | | |
| I _{REF+} Operating supply current into AVCC terminal ⁽²⁾ ⁽³⁾ | ADC12SR = 1 ⁽⁴⁾ , REFON = 1, REFOUT = 0, REFBURST = 0 | 3 V | | 70 | 105 | μA |
| | ADC12SR = 1 ⁽⁴⁾ , REFON = 1, REFOUT = 1, REFBURST = 0 | 3 V | | 0.45 | 0.76 | mA |
| | ADC12SR = 0 ⁽⁴⁾ , REFON = 1, REFOUT = 0, REFBURST = 0 | 3 V | | 210 | 315 | μA |
| | ADC12SR = 0 ⁽⁴⁾ , REFON = 1, REFOUT = 1, REFBURST = 0 | 3 V | | 0.95 | 1.72 | mA |
| I _{L(VREF+)} Load-current regulation, VREF+ terminal ⁽⁵⁾ | REFVSEL = (0, 1, 2), I _{VREF+} = +10 μA–1000 μA, AVCC = AVCC(min) for each reference level, REFVSEL = (0, 1, 2), REFON = REFOUT = 1 | | | 2500 | | μV/mA |
| C _{VREF+} Capacitance at VREF+ terminals ⁽⁶⁾ | REFON = REFOUT = 1 | | 20 | | 100 | pF |
| TC _{REF+} Temperature coefficient of built-in reference ⁽⁷⁾ | I _{VREF+} = 0 A, REFVSEL = (0, 1, 2), REFON = 1, REFOUT = 0 or 1 | | | 30 | | ppm/°C |
| PSRR _{DC} Power supply rejection ratio (DC) | AVCC = AVCC(min) - AVCC(max), REFVSEL = (0, 1, 2), REFON = 1, REFOUT = 0 or 1 | | | 120 | 300 | μV/V |
| PSRR _{AC} Power supply rejection ratio (AC) | AVCC = AVCC(min) - AVCC(max), T _A = 25°C, f = 1 kHz, ΔV _{pp} = 100 mV, REFVSEL = (0, 1, 2), REFON = 1, REFOUT = 0 or 1 | | | 6.4 | | mV/V |
| t _{SETTLE} Settling time of reference voltage ⁽⁸⁾ | AVCC = AVCC(min) - AVCC(max), REFVSEL = (0, 1, 2), REFOUT = 0, REFON = 0 → 1 | | | 75 | | μs |
| | AVCC = AVCC(min) - AVCC(max), C _{VREF} = C _{VREF(max)} , REFVSEL = (0, 1, 2), REFOUT = 1, REFON = 0 → 1 | | | 75 | | |

- (1) The reference is supplied to the ADC by the REF module and is buffered locally inside the ADC. The ADC uses two internal buffers, one smaller and one larger for driving the V_{REF+} terminal. When REFOUT = 1, the reference is available at the V_{REF+} terminal, as well as, used as the reference for the conversion and utilizes the larger buffer. When REFOUT = 0, the reference is only used as the reference for the conversion and utilizes the smaller buffer.
- (2) The internal reference current is supplied via terminal AVCC. Consumption is independent of the ADC12ON control bit, unless a conversion is active. REFOUT = 0 represents the current contribution of the smaller buffer. REFOUT = 1 represents the current contribution of the larger buffer without external load.
- (3) The temperature sensor is provided by the REF module. Its current is supplied via terminal AV_{CC} and is equivalent to I_{REF+} with REFON = 1 and REFOUT = 0.
- (4) For devices without the ADC12, the parametric with ADC12SR = 0 are applicable.
- (5) Contribution only due to the reference and buffer including package. This does not include resistance due to PCB trace, etc.
- (6) Ensured for -40°C to 85°C.
- (7) Calculated using the box method: (MAX(-40 to 105°C) – MIN(-40 to 105°C)) / MIN(-40 to 105°C)/(105°C – (-40°C)).
- (8) The condition is that the error in a conversion started after t_{REFON} is less than ±0.5 LSB. The settling time depends on the external capacitive load when REFOUT = 1.

Comparator B

over recommended ranges of supply voltage and operating free-air temperature (unless otherwise noted)

| PARAMETER | | TEST CONDITIONS | V _{CC} | MIN | TYP | MAX | UNIT | |
|------------------------|--|--|-----------------|------|-----|------------------------------|------|----|
| V _{CC} | Supply voltage | | | 1.8 | | 3.6 | V | |
| I _{AVCC_COMP} | Comparator operating supply current into AVCC. Excludes reference resistor ladder. | CBPWRMD = 00 | 1.8 V | | 20 | | μA | |
| | | | 2.2 V | | 30 | 50 | | |
| | | | 3 V | | 40 | 65 | | |
| | | 2.2/3 V | | 10 | 30 | | | |
| | | CBPWRMD = 10 | 2.2/3 V | | 0.1 | 0.51 | | |
| I _{AVCC_REF} | Quiescent current of local reference voltage amplifier into AVCC | CBREFACC = 1, CBREFLx = 01 | | | | 22 | μA | |
| V _{IC} | Common mode input range | | | 0 | | V _{CC} -1 | V | |
| V _{OFFSET} | Input offset voltage | CBPWRMD = 00 | | | | ±20 | mV | |
| | | CBPWRMD = 01, 10 | | | | ±10 | mV | |
| C _{IN} | Input capacitance | | | | 5 | | pF | |
| R _{SIN} | Series input resistance | ON - switch closed | | | | 3 | 4 | kΩ |
| | | OFF - switch opened | | | | 30 ⁽¹⁾ | | MΩ |
| t _{PD} | Propagation delay, response time | CBPWRMD = 00, CBF = 0 | | | | | 450 | ns |
| | | CBPWRMD = 01, CBF = 0 | | | | | 600 | ns |
| | | CBPWRMD = 10, CBF = 0 | | | | | 50 | μs |
| t _{PD,filter} | Propagation delay with filter active | CBPWRMD = 00, CBON = 1, CBF = 1, CBF _{DLY} = 00 | | 0.35 | 0.6 | 1.82 | μs | |
| | | CBPWRMD = 00, CBON = 1, CBF = 1, CBF _{DLY} = 01 | | 0.58 | 1.0 | 1.82 | μs | |
| | | CBPWRMD = 00, CBON = 1, CBF = 1, CBF _{DLY} = 10 | | 0.97 | 1.8 | 3.43 | μs | |
| | | CBPWRMD = 00, CBON = 1, CBF = 1, CBF _{DLY} = 11 | | 1.74 | 3.4 | 6.56 | μs | |
| t _{EN_CMP} | Comparator enable time, settling time | CBON = 0 to CBON = 1 CBPWRMD = 00, 01, 10 | | | | 1 | 2.1 | μs |
| t _{EN_REF} | Resistor reference enable time | CBON = 0 to CBON = 1 | | | | 1 | 1.5 | μs |
| V _{CB_REF} | Reference voltage for a given tap | V _{IN} = reference into resistor ladder (n = 0 to 31) | | | | V _{IN} × (n+1) / 32 | V | |

(1) Ensured for -40°C to 85°C.

Ports PU.0 and PU.1

over recommended ranges of supply voltage and operating free-air temperature (unless otherwise noted)

| PARAMETER | | TEST CONDITIONS | V _{CC} | MIN | TYP | MAX | UNIT |
|-----------------|---------------------------|---|-----------------|-----|-----|-----|------|
| V _{OH} | High-level output voltage | V _{LDOO} = 3.3 V ± 10%, I _{OH} = -25 mA, See Figure 18 for typical characteristics | | 2.4 | | | V |
| V _{OL} | Low-level output voltage | V _{LDOO} = 3.3 V ± 10%, I _{OL} = 25 mA, See Figure 17 for typical characteristics | | | | 0.4 | V |
| V _{IH} | High-level input voltage | V _{LDOO} = 3.3 V ± 10%, See Figure 19 for typical characteristics | | 2.0 | | | V |
| V _{IL} | Low-level input voltage | V _{LDOO} = 3.3 V ± 10%, See Figure 19 for typical characteristics | | | | 0.8 | V |

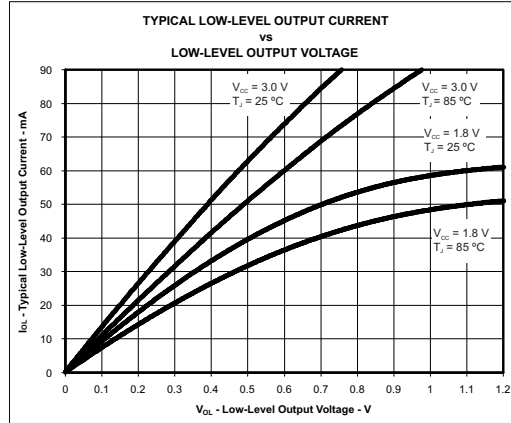

Figure 17. Ports PU.0, PU.1 Typical Low-Level Output Characteristics

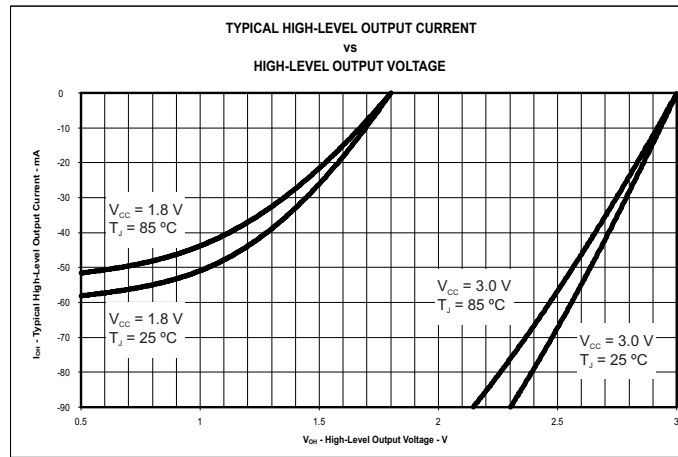

Figure 18. Ports PU.0, PU.1 Typical High-Level Output Characteristics

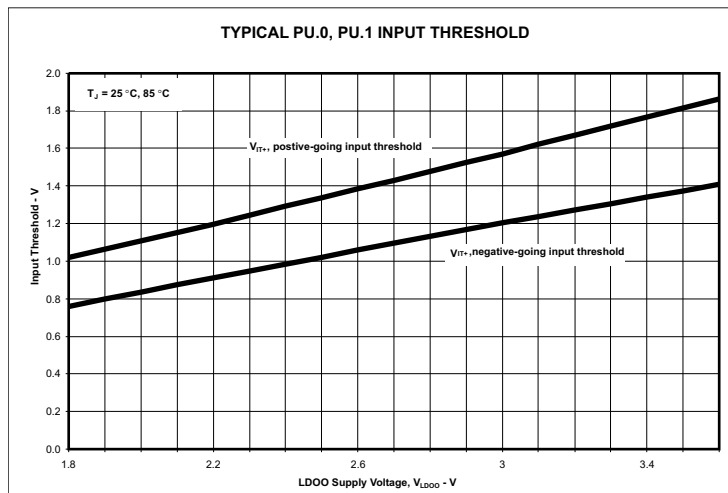

Figure 19. Ports PU.0, PU.1 Typical Input Threshold Characteristics

LDO-PWR (LDO Power System)

over recommended ranges of supply voltage and operating free-air temperature (unless otherwise noted)

| PARAMETER | | TEST CONDITIONS | MIN | TYP | MAX | UNIT |
|----------------------|--|-------------------------------------|------|-----|------|------|
| V _{LAUNCH} | LDO input detection threshold | | | | 3.75 | V |
| V _{LDOI} | LDO input voltage | | 3.76 | | 5.5 | V |
| V _{LDO} | LDO output voltage | | | 3.3 | ±11% | V |
| V _{LDO_EXT} | LDOO terminal input voltage with LDO disabled | LDO disabled | 1.8 | | 3.6 | V |
| I _{LDOO} | Maximum external current from LDOO terminal ⁽¹⁾ | LDO is on | | | 20 | mA |
| I _{DET} | LDO current overload detection ⁽²⁾ | | 55 | | 105 | mA |
| C _{LDOI} | LDOI terminal recommended capacitance | | | 4.7 | | μF |
| C _{LDOO} | LDOO terminal recommended capacitance | | | 220 | | nF |
| t _{ENABLE} | Settling time V _{LDO} | Within 2%, recommended capacitances | | | 2.1 | ms |

(1) Ensured for -40°C to 85°C.

(2) A current overload is detected when the total current supplied from the LDO exceeds this value.

Flash Memory

over recommended ranges of supply voltage and operating free-air temperature (unless otherwise noted)

| PARAMETER | | TEST CONDITIONS | MIN | TYP | MAX | UNIT |
|---|---|-----------------------|-----------------|-----------------|-----|--------|
| DV _{CC(PGM/ERASE)} | Program or erase supply voltage | | 1.8 | | 3.6 | V |
| I _{PGM} | Average supply current from DVCC during program | | | 3 | 8.5 | mA |
| I _{ERASE} | Average supply current from DVCC during erase | | | 6 | 12 | mA |
| I _{MERASE} , I _{BANK} | Average supply current from DVCC during mass erase or bank erase | | | 6 | 12 | mA |
| t _{CPT} | Cumulative program time | See ⁽¹⁾ | | | 16 | ms |
| | Program and erase endurance | | 10 ⁴ | 10 ⁵ | | cycles |
| t _{Retention} | Data retention duration | T _J = 25°C | 100 | | | years |
| t _{Word} | Word or byte program time | See ⁽²⁾ | 64 | | 85 | μs |
| t _{Block, 0} | Block program time for first byte or word | See ⁽²⁾ | 49 | | 65 | μs |
| t _{Block, 1–(N–1)} | Block program time for each additional byte or word, except for last byte or word | See ⁽²⁾ | 37 | | 49 | μs |
| t _{Block, N} | Block program time for last byte or word | See ⁽²⁾ | 55 | | 73 | μs |
| t _{Erase} | Erase time for segment, mass erase, and bank erase (when available) | See ⁽²⁾ | 23 | | 32 | ms |
| f _{MCLK,MGR} | MCLK frequency in marginal read mode (FCTL4.MGR0 = 1 or FCTL4.MGR1 = 1) | | 0 | | 1 | MHz |

(1) The cumulative program time must not be exceeded when writing to a 128-byte flash block. This parameter applies to all programming methods: individual word/byte write and block write modes.

(2) These values are hardwired into the flash controller's state machine. Ensured for -40°C to 85°C.

JTAG and Spy-Bi-Wire Interface

over recommended ranges of supply voltage and operating free-air temperature (unless otherwise noted)

| PARAMETER | | V _{CC} | MIN | TYP | MAX | UNIT |
|-----------------------|--|-----------------|-------|-----|-----|------|
| f _{SBW} | Spy-Bi-Wire input frequency | 2.2 V, 3 V | 0 | | 20 | MHz |
| t _{SBW,Low} | Spy-Bi-Wire low clock pulse length | 2.2 V, 3 V | 0.025 | | 15 | μs |
| t _{SBW,En} | Spy-Bi-Wire enable time (TEST high to acceptance of first clock edge) ⁽¹⁾ | 2.2 V, 3 V | | | 1 | μs |
| t _{SBW,Rst} | Spy-Bi-Wire return to normal operation time | | 10 | | 100 | μs |
| f _{TCK} | TCK input frequency, 4-wire JTAG ⁽²⁾ | 2.2 V | 0 | | 5 | MHz |
| | | 3 V | 0 | | 10 | MHz |
| R _{internal} | Internal pulldown resistance on TEST | 2.2 V, 3 V | 45 | 60 | 80 | kΩ |

- (1) Tools accessing the Spy-Bi-Wire interface need to wait for the t_{SBW,En} time after pulling the TEST/SBWTCK pin high before applying the first SBWTCK clock edge.
- (2) f_{TCK} may be restricted to meet the timing requirements of the module selected.

INPUT/OUTPUT SCHEMATICS

Port P1, P1.0 to P1.7, Input/Output With Schmitt Trigger

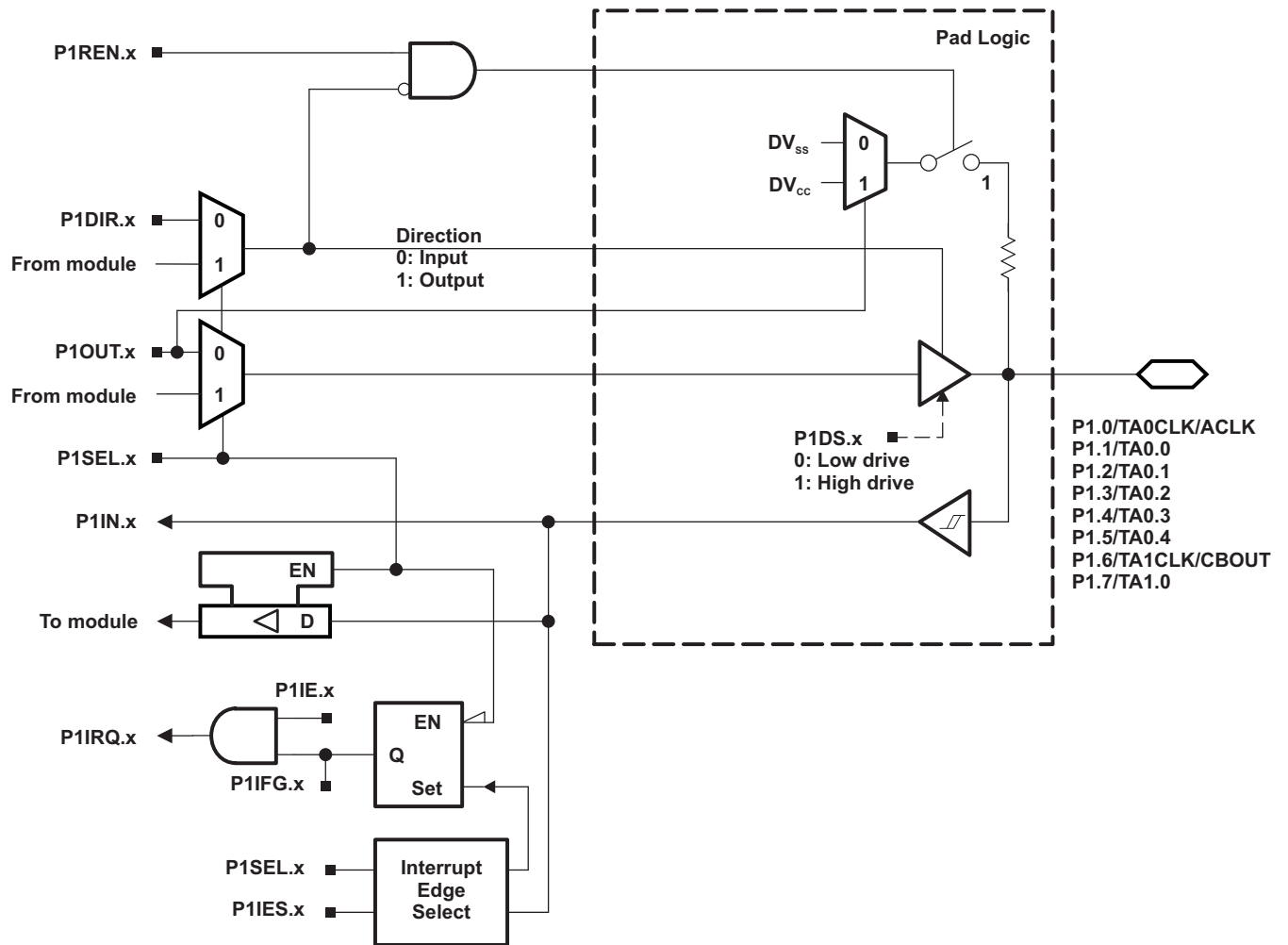

Table 45. Port P1 (P1.0 to P1.7) Pin Functions

| PIN NAME (P1.x) | x | FUNCTION | CONTROL BITS/SIGNALS | |
|-------------------|---|--------------------|----------------------|---------|
| | | | P1DIR.x | P1SEL.x |
| P1.0/TA0CLK/ACLK | 0 | P1.0 (I/O) | I: 0; O: 1 | 0 |
| | | TA0CLK | 0 | 1 |
| | | ACLK | 1 | 1 |
| P1.1/TA0.0 | 1 | P1.1 (I/O) | I: 0; O: 1 | 0 |
| | | TA0.CCI0A | 0 | 1 |
| | | TA0.0 | 1 | 1 |
| P1.2/TA0.1 | 2 | P1.2 (I/O) | I: 0; O: 1 | 0 |
| | | TA0.CCI1A | 0 | 1 |
| | | TA0.1 | 1 | 1 |
| P1.3/TA0.2 | 3 | P1.3 (I/O) | I: 0; O: 1 | 0 |
| | | TA0.CCI2A | 0 | 1 |
| | | TA0.2 | 1 | 1 |
| P1.4/TA0.3 | 4 | P1.4 (I/O) | I: 0; O: 1 | 0 |
| | | TA0.CCI3A | 0 | 1 |
| | | TA0.3 | 1 | 1 |
| P1.5/TA0.4 | 5 | P1.5 (I/O) | I: 0; O: 1 | 0 |
| | | TA0.CCI4A | 0 | 1 |
| | | TA0.4 | 1 | 1 |
| P1.6/TA1CLK/CBOUT | 6 | P1.6 (I/O) | I: 0; O: 1 | 0 |
| | | TA1CLK | 0 | 1 |
| | | CBOUT comparator B | 1 | 1 |
| P1.7/TA1.0 | 7 | P1.7 (I/O) | I: 0; O: 1 | 0 |
| | | TA1.CCI0A | 0 | 1 |
| | | TA1.0 | 1 | 1 |

Port P2, P2.0 to P2.7, Input/Output With Schmitt Trigger

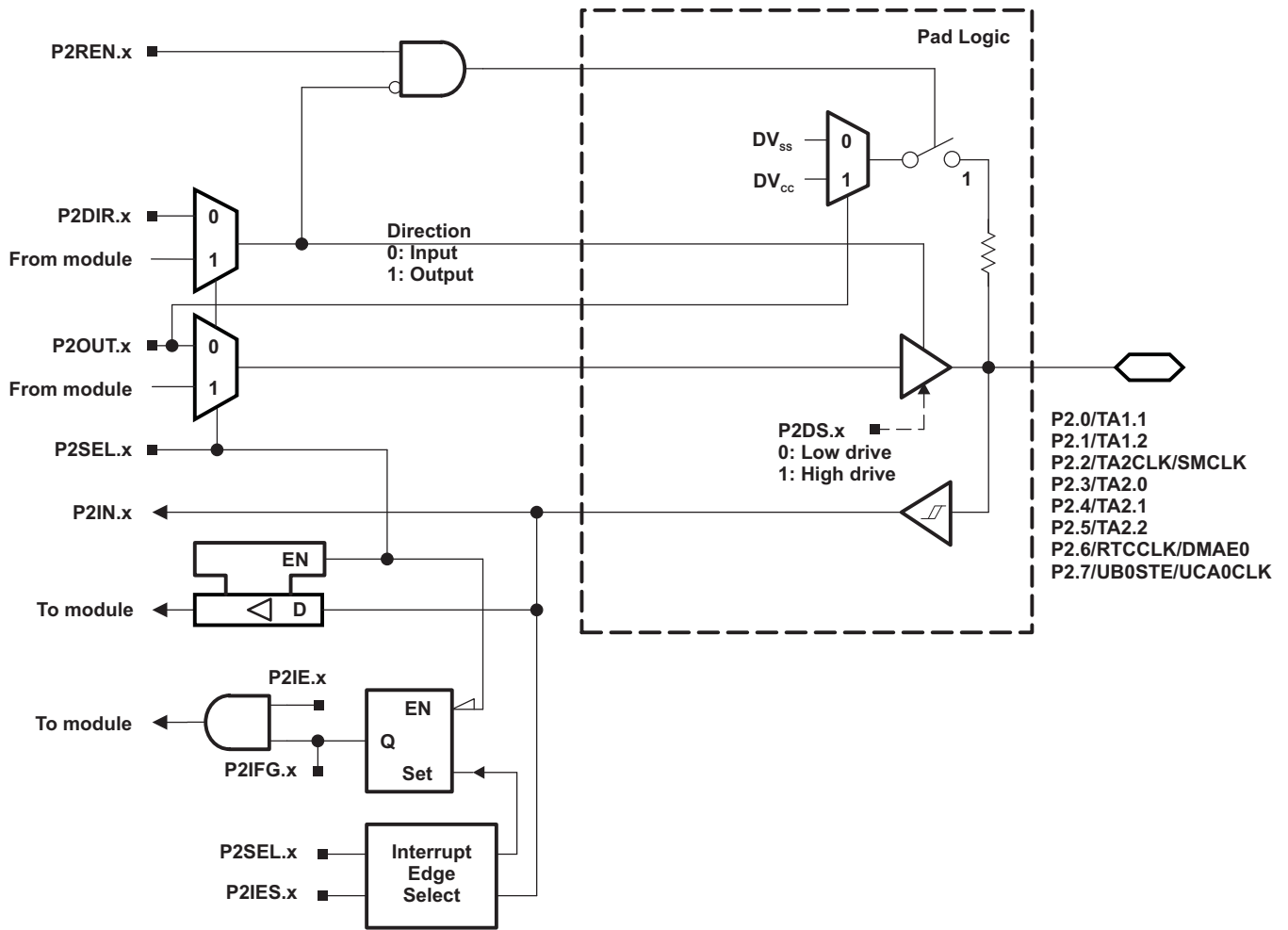

Table 46. Port P2 (P2.0 to P2.7) Pin Functions

| PIN NAME (P2.x) | x | FUNCTION | CONTROL BITS/SIGNALS ⁽¹⁾ | |
|----------------------|---|------------------------------------|-------------------------------------|---------|
| | | | P2DIR.x | P2SEL.x |
| P2.0/TA1.1 | 0 | P2.0 (I/O) | I: 0; O: 1 | 0 |
| | | TA1.CCI1A | 0 | 1 |
| | | TA1.1 | 1 | 1 |
| P2.1/TA1.2 | 1 | P2.1 (I/O) | I: 0; O: 1 | 0 |
| | | TA1.CCI2A | 0 | 1 |
| | | TA1.2 | 1 | 1 |
| P2.2/TA2CLK/SMCLK | 2 | P2.2 (I/O) | I: 0; O: 1 | 0 |
| | | TA2CLK | 0 | 1 |
| | | SMCLK | 1 | 1 |
| P2.3/TA2.0 | 3 | P2.3 (I/O) | I: 0; O: 1 | 0 |
| | | TA2.CCI0A | 0 | 1 |
| | | TA2.0 | 1 | 1 |
| P2.4/TA2.1 | 4 | P2.4 (I/O) | I: 0; O: 1 | 0 |
| | | TA2.CCI1A | 0 | 1 |
| | | TA2.1 | 1 | 1 |
| P2.5/TA2.2 | 5 | P2.5 (I/O) | I: 0; O: 1 | 0 |
| | | TA2.CCI2A | 0 | 1 |
| | | TA2.2 | 1 | 1 |
| P2.6/RTCCLK/DMAE0 | 6 | P2.6 (I/O) | I: 0; O: 1 | 0 |
| | | DMAE0 | 0 | 1 |
| | | RTCCLK | 1 | 1 |
| P2.7/UCB0STE/UCA0CLK | 7 | P2.7 (I/O) | I: 0; O: 1 | 0 |
| | | UCB0STE/UCA0CLK ^{(2) (3)} | X | 1 |

(1) X = Don't care

(2) The pin direction is controlled by the USCI module.

(3) UCA0CLK function takes precedence over UCB0STE function. If the pin is required as UCA0CLK input or output, USCI B0 is forced to 3-wire SPI mode if 4-wire SPI mode is selected.

Port P3, P3.0 to P3.7, Input/Output With Schmitt Trigger

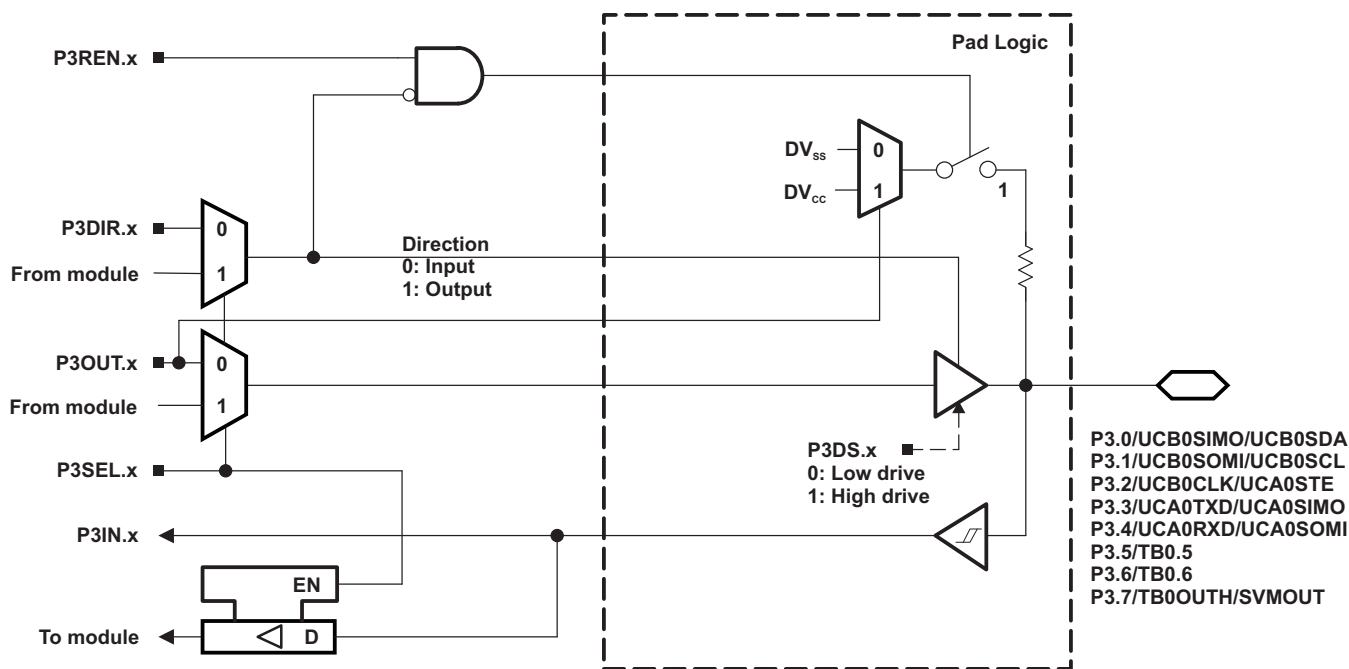

Table 47. Port P3 (P3.0 to P3.7) Pin Functions

| PIN NAME (P3.x) | x | FUNCTION | CONTROL BITS/SIGNALS ⁽¹⁾ | |
|------------------------------------|---|-------------------------------------|-------------------------------------|---------|
| | | | P3DIR.x | P3SEL.x |
| P3.0/UCB0SIMO/UCB0SDA | 0 | P3.0 (I/O) | I: 0; O: 1 | 0 |
| | | UCB0SIMO/UCB0SDA ^{(2) (3)} | X | 1 |
| P3.1/UCB0SOMI/UCB0SCL | 1 | P3.1 (I/O) | I: 0; O: 1 | 0 |
| | | UCB0SOMI/UCB0SCL ^{(2) (3)} | X | 1 |
| P3.2/UCB0CLK/UCA0STE | 2 | P3.2 (I/O) | I: 0; O: 1 | 0 |
| | | UCB0CLK/UCA0STE ^{(2) (4)} | X | 1 |
| P3.3/UCA0TXD/UCA0SIMO | 3 | P3.3 (I/O) | I: 0; O: 1 | 0 |
| | | UCA0TXD/UCA0SIMO ⁽²⁾ | X | 1 |
| P3.4/UCA0RXD/UCA0SOMI | 4 | P3.4 (I/O) | I: 0; O: 1 | 0 |
| | | UCA0RXD/UCA0SOMI ⁽²⁾ | X | 1 |
| P3.5/TB0.5 ⁽⁵⁾ | 5 | P3.5 (I/O) | I: 0; O: 1 | 0 |
| | | TB0.CCI5A | 0 | 1 |
| | | TB0.5 | 1 | 1 |
| P3.6/TB0.6 ⁽⁵⁾ | 6 | P3.6 (I/O) | I: 0; O: 1 | 0 |
| | | TB0.CCI6A | 0 | 1 |
| | | TB0.6 | 1 | 1 |
| P3.7/TB0OUTH/SVMOUT ⁽⁵⁾ | 7 | P3.7 (I/O) | I: 0; O: 1 | 0 |
| | | TB0OUTH | 0 | 1 |
| | | SVMOUT | 1 | 1 |

(1) X = Don't care
 (2) The pin direction is controlled by the USCI module.
 (3) If the I2C functionality is selected, the output drives only the logical 0 to V_{SS} level.
 (4) UCB0CLK function takes precedence over UCA0STE function. If the pin is required as UCB0CLK input or output, USCI A0 is forced to 3-wire SPI mode if 4-wire SPI mode is selected.
 (5) F5329, F5327, F5325 devices only.

Port P4, P4.0 to P4.7, Input/Output With Schmitt Trigger

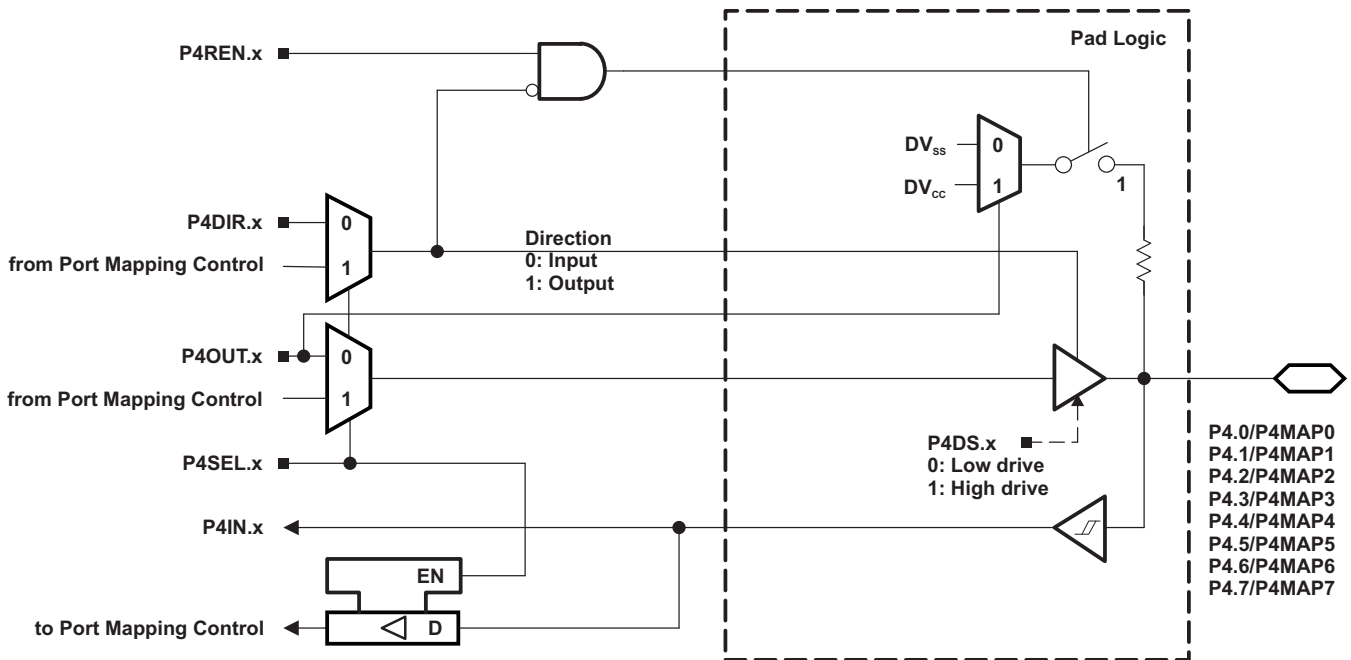

Table 48. Port P4 (P4.0 to P4.7) Pin Functions

| PIN NAME (P4.x) | x | FUNCTION | CONTROL BITS/SIGNALS | | |
|-----------------|---|-----------------------------------|------------------------|---------|--------|
| | | | P4DIR.x ⁽¹⁾ | P4SEL.x | P4MAPx |
| P4.0/P4MAP0 | 0 | P4.0 (I/O) | I: 0; O: 1 | 0 | X |
| | | Mapped secondary digital function | X | 1 | ≤ 30 |
| P4.1/P4MAP1 | 1 | P4.1 (I/O) | I: 0; O: 1 | 0 | X |
| | | Mapped secondary digital function | X | 1 | ≤ 30 |
| P4.2/P4MAP2 | 2 | P4.2 (I/O) | I: 0; O: 1 | 0 | X |
| | | Mapped secondary digital function | X | 1 | ≤ 30 |
| P4.3/P4MAP3 | 3 | P4.3 (I/O) | I: 0; O: 1 | 0 | X |
| | | Mapped secondary digital function | X | 1 | ≤ 30 |
| P4.4/P4MAP4 | 4 | P4.4 (I/O) | I: 0; O: 1 | 0 | X |
| | | Mapped secondary digital function | X | 1 | ≤ 30 |
| P4.5/P4MAP5 | 5 | P4.5 (I/O) | I: 0; O: 1 | 0 | X |
| | | Mapped secondary digital function | X | 1 | ≤ 30 |
| P4.6/P4MAP6 | 6 | P4.6 (I/O) | I: 0; O: 1 | 0 | X |
| | | Mapped secondary digital function | X | 1 | ≤ 30 |
| P4.7/P4MAP7 | 7 | P4.7 (I/O) | I: 0; O: 1 | 0 | X |
| | | Mapped secondary digital function | X | 1 | ≤ 30 |

(1) The direction of some mapped secondary functions are controlled directly by the module. See Table 7 for specific direction control information of mapped secondary functions.

Port P5, P5.0 and P5.1, Input/Output With Schmitt Trigger

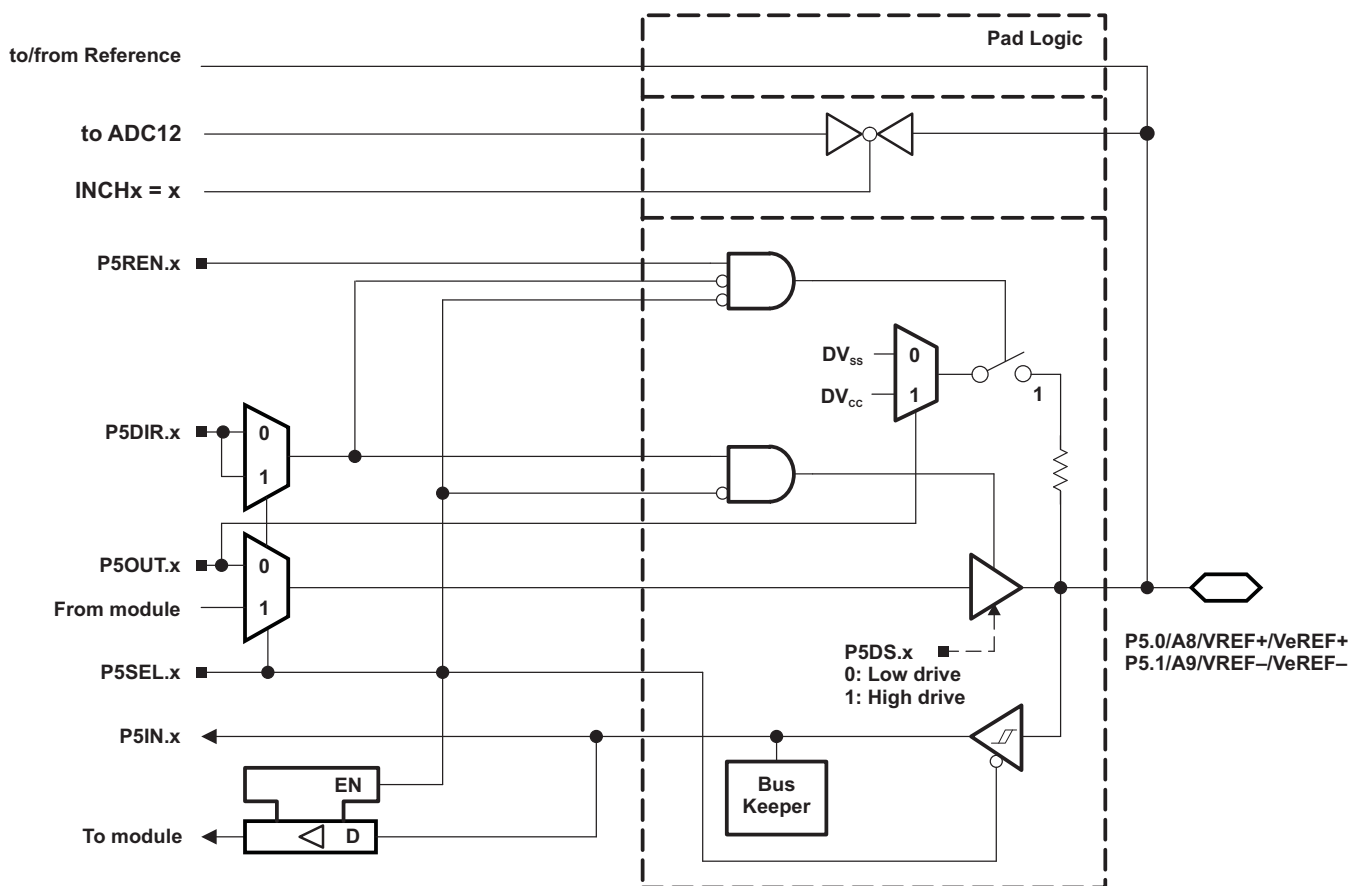
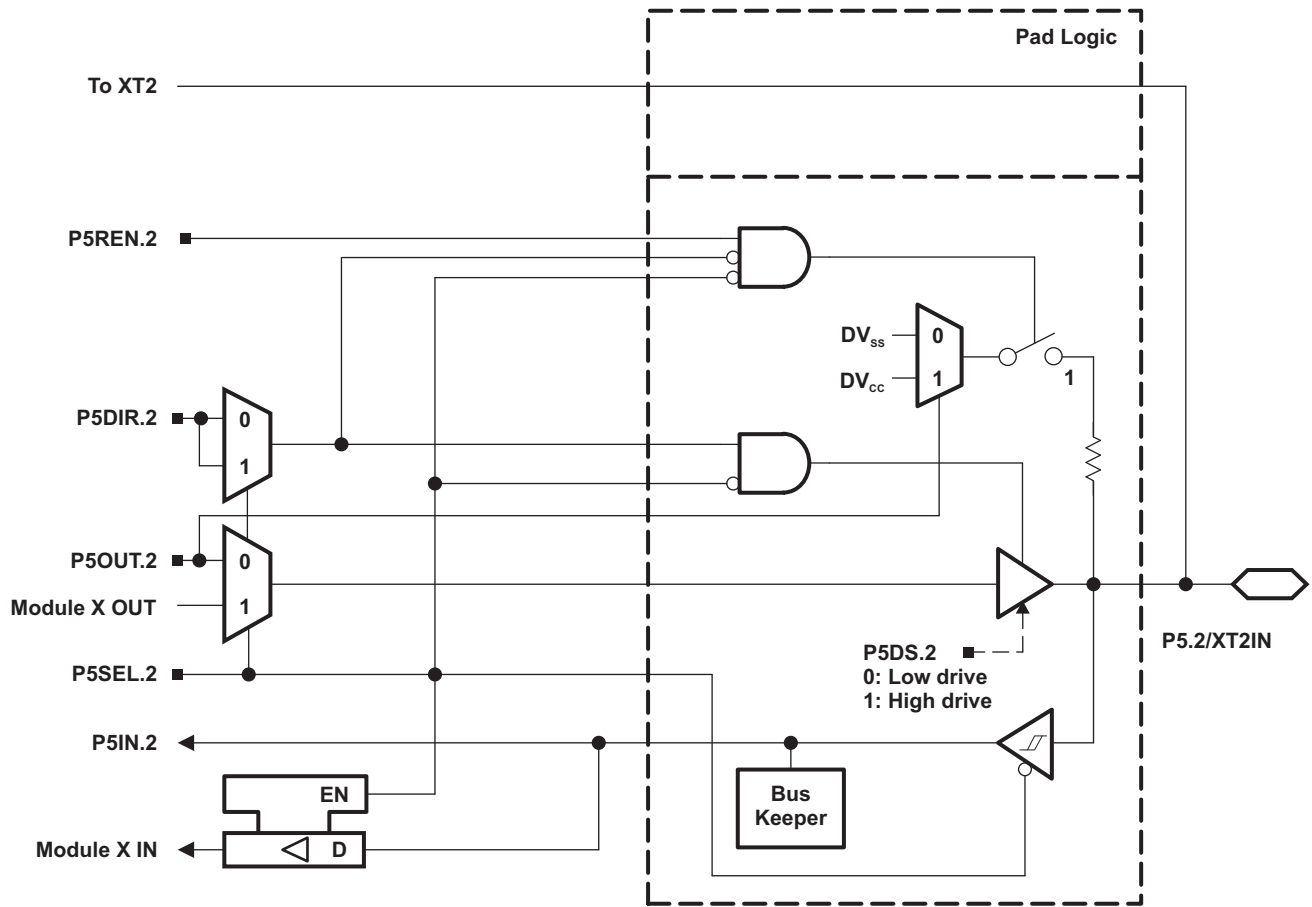

Table 49. Port P5 (P5.0 and P5.1) Pin Functions

| PIN NAME (P5.x) | x | FUNCTION | CONTROL BITS/SIGNALS ⁽¹⁾ | | |
|----------------------|---|---------------------------|-------------------------------------|---------|--------|
| | | | P5DIR.x | P5SEL.x | REFOUT |
| P5.0/A8/VREF+/VeREF+ | 0 | P5.0 (I/O) ⁽²⁾ | I: 0; O: 1 | 0 | X |
| | | A8/VeREF+ ⁽³⁾ | X | 1 | 0 |
| | | A8/VREF+ ⁽⁴⁾ | X | 1 | 1 |
| P5.1/A9/VREF-/VeREF- | 1 | P5.1 (I/O) ⁽²⁾ | I: 0; O: 1 | 0 | X |
| | | A9/VeREF- ⁽⁵⁾ | X | 1 | 0 |
| | | A9/VREF- ⁽⁶⁾ | X | 1 | 1 |

- (1) X = Don't care
- (2) Default condition
- (3) Setting the P5SEL.0 bit disables the output driver as well as the input Schmitt trigger to prevent parasitic cross currents when applying analog signals. An external voltage can be applied to VeREF+ and used as the reference for the ADC12_A. Channel A8, when selected with the INCHx bits, is connected to the VREF+/VeREF+ pin.
- (4) Setting the P5SEL.0 bit disables the output driver as well as the input Schmitt trigger to prevent parasitic cross currents when applying analog signals. The VREF+ reference is available at the pin. Channel A8, when selected with the INCHx bits, is connected to the VREF+/VeREF+ pin.
- (5) Setting the P5SEL.1 bit disables the output driver as well as the input Schmitt trigger to prevent parasitic cross currents when applying analog signals. An external voltage can be applied to VeREF- and used as the reference for the ADC12_A. Channel A9, when selected with the INCHx bits, is connected to the VREF-/VeREF- pin.
- (6) Setting the P5SEL.1 bit disables the output driver as well as the input Schmitt trigger to prevent parasitic cross currents when applying analog signals. The VREF- reference is available at the pin. Channel A9, when selected with the INCHx bits, is connected to the VREF-/VeREF- pin.

Port P5, P5.2, Input/Output With Schmitt Trigger



Port P5, P5.3, Input/Output With Schmitt Trigger

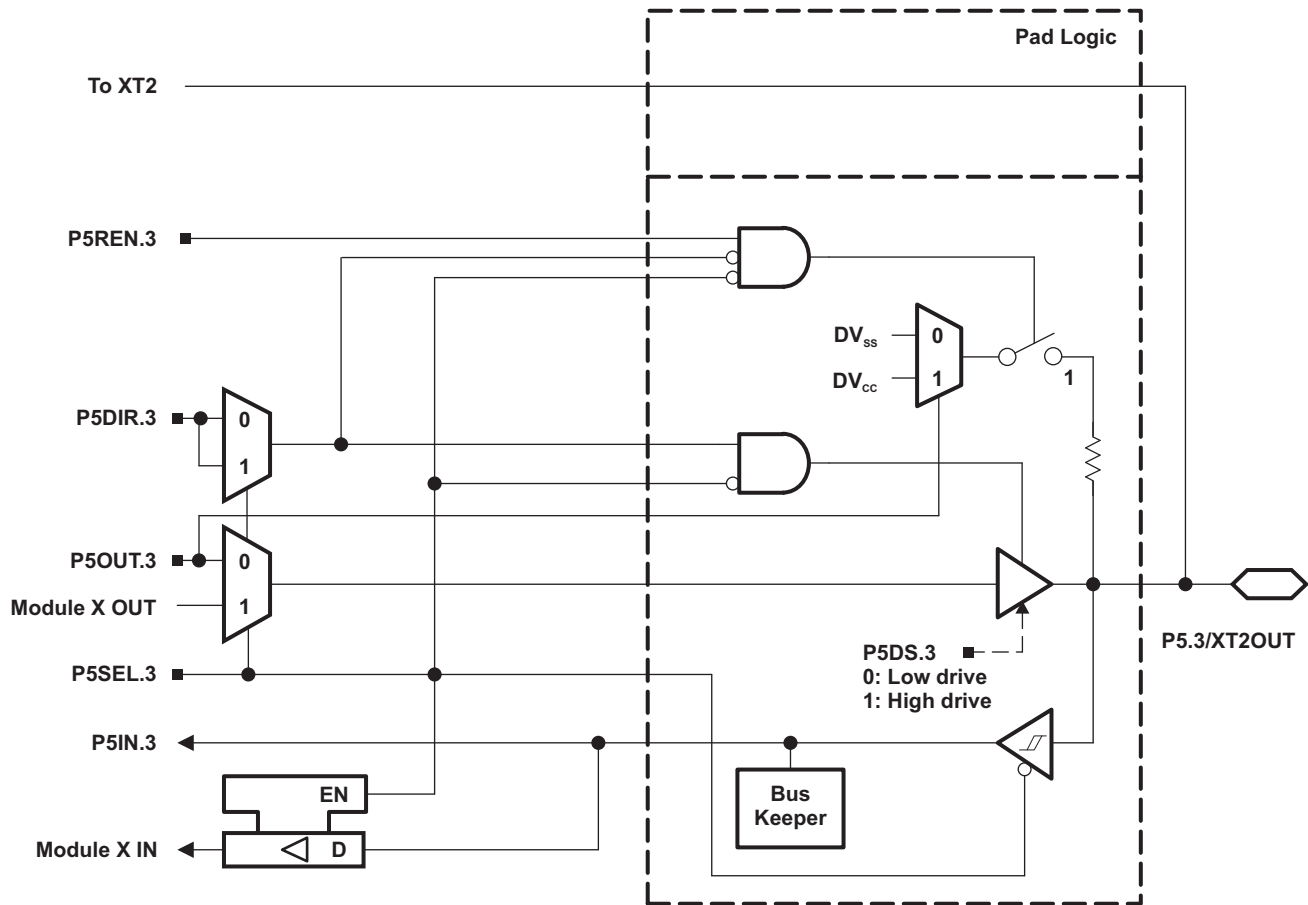
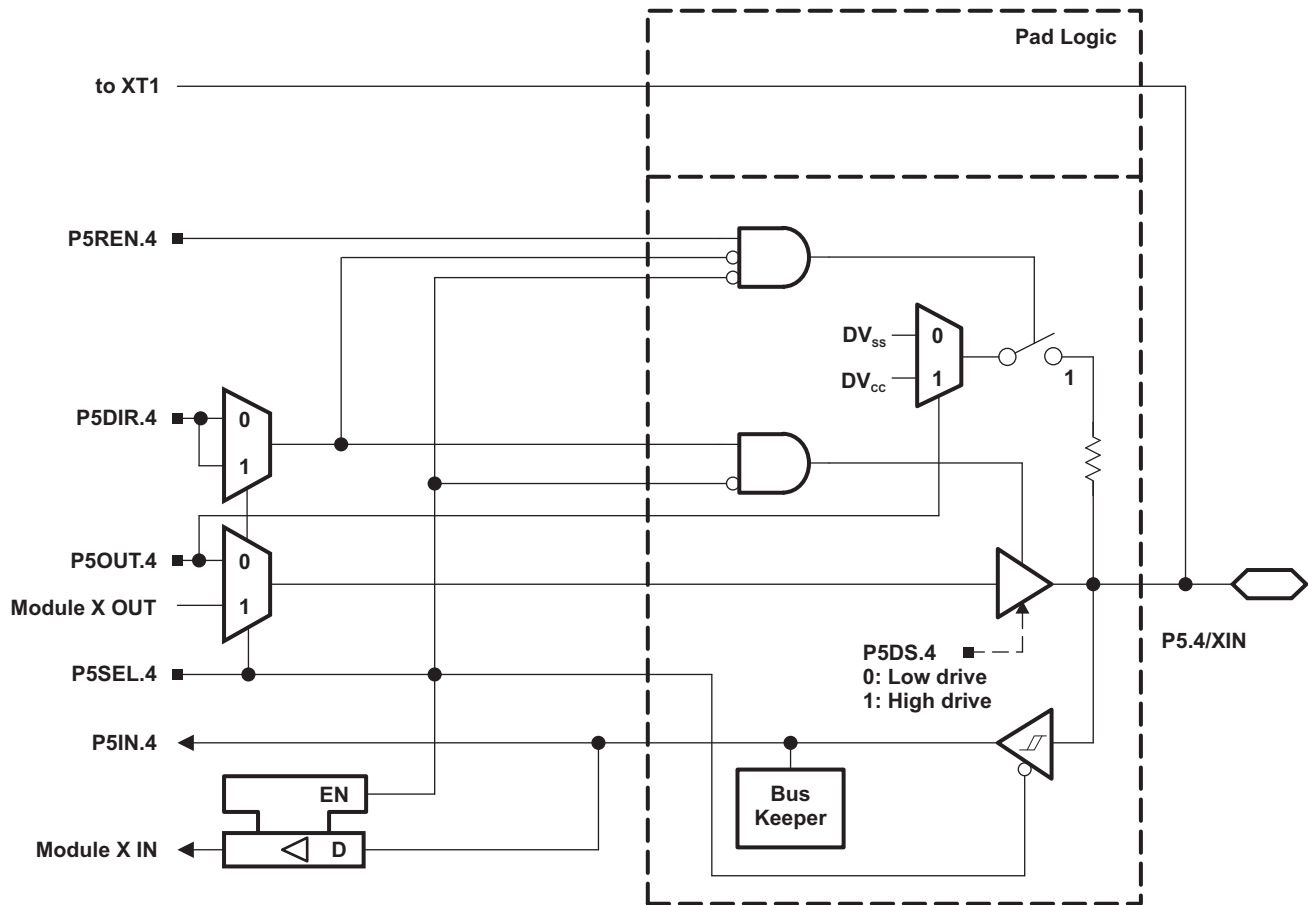

Table 50. Port P5 (P5.2, P5.3) Pin Functions

| PIN NAME (P5.x) | x | FUNCTION | CONTROL BITS/SIGNALS ⁽¹⁾ | | | |
|-----------------|---|------------------------------------|-------------------------------------|---------|---------|-----------|
| | | | P5DIR.x | P5SEL.2 | P5SEL.3 | XT2BYPASS |
| P5.2/XT2IN | 2 | P5.2 (I/O) | I: 0; O: 1 | 0 | X | X |
| | | XT2IN crystal mode ⁽²⁾ | X | 1 | X | 0 |
| | | XT2IN bypass mode ⁽²⁾ | X | 1 | X | 1 |
| P5.3/XT2OUT | 3 | P5.3 (I/O) | I: 0; O: 1 | 0 | X | X |
| | | XT2OUT crystal mode ⁽³⁾ | X | 1 | X | 0 |
| | | P5.3 (I/O) ⁽³⁾ | X | 1 | X | 1 |

- (1) X = Don't care
- (2) Setting P5SEL.2 causes the general-purpose I/O to be disabled. Pending the setting of XT2BYPASS, P5.2 is configured for crystal mode or bypass mode.
- (3) Setting P5SEL.2 causes the general-purpose I/O to be disabled in crystal mode. When using bypass mode, P5.3 can be used as general-purpose I/O.

Port P5, P5.4 and P5.5 Input/Output With Schmitt Trigger



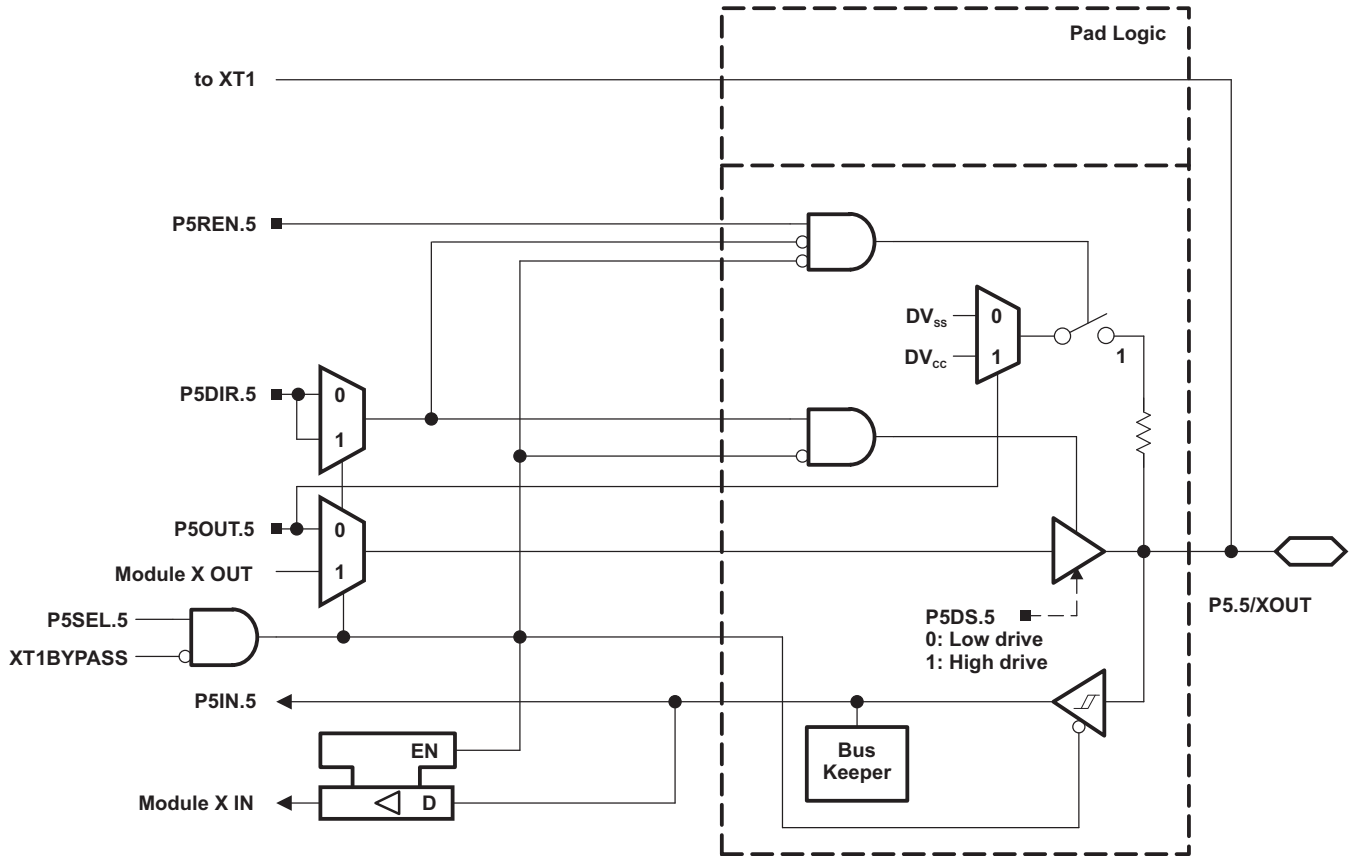

Table 51. Port P5 (P5.4 and P5.5) Pin Functions

| PIN NAME (P5.x) | x | FUNCTION | CONTROL BITS/SIGNALS ⁽¹⁾ | | | |
|-----------------|---|----------------------------------|-------------------------------------|---------|---------|-----------|
| | | | P5DIR.x | P5SEL.4 | P5SEL.5 | XT1BYPASS |
| P5.4/XIN | 4 | P5.4 (I/O) | I: 0; O: 1 | 0 | X | X |
| | | XIN crystal mode ⁽²⁾ | X | 1 | X | 0 |
| | | XIN bypass mode ⁽²⁾ | X | 1 | X | 1 |
| P5.5/XOUT | 5 | P5.5 (I/O) | I: 0; O: 1 | 0 | X | X |
| | | XOUT crystal mode ⁽³⁾ | X | 1 | X | 0 |
| | | P5.5 (I/O) ⁽³⁾ | X | 1 | X | 1 |

- (1) X = Don't care
- (2) Setting P5SEL.4 causes the general-purpose I/O to be disabled. Pending the setting of XT1BYPASS, P5.4 is configured for crystal mode or bypass mode.
- (3) Setting P5SEL.4 causes the general-purpose I/O to be disabled in crystal mode. When using bypass mode, P5.5 can be used as general-purpose I/O.

Port P5, P5.6 to P5.7, Input/Output With Schmitt Trigger

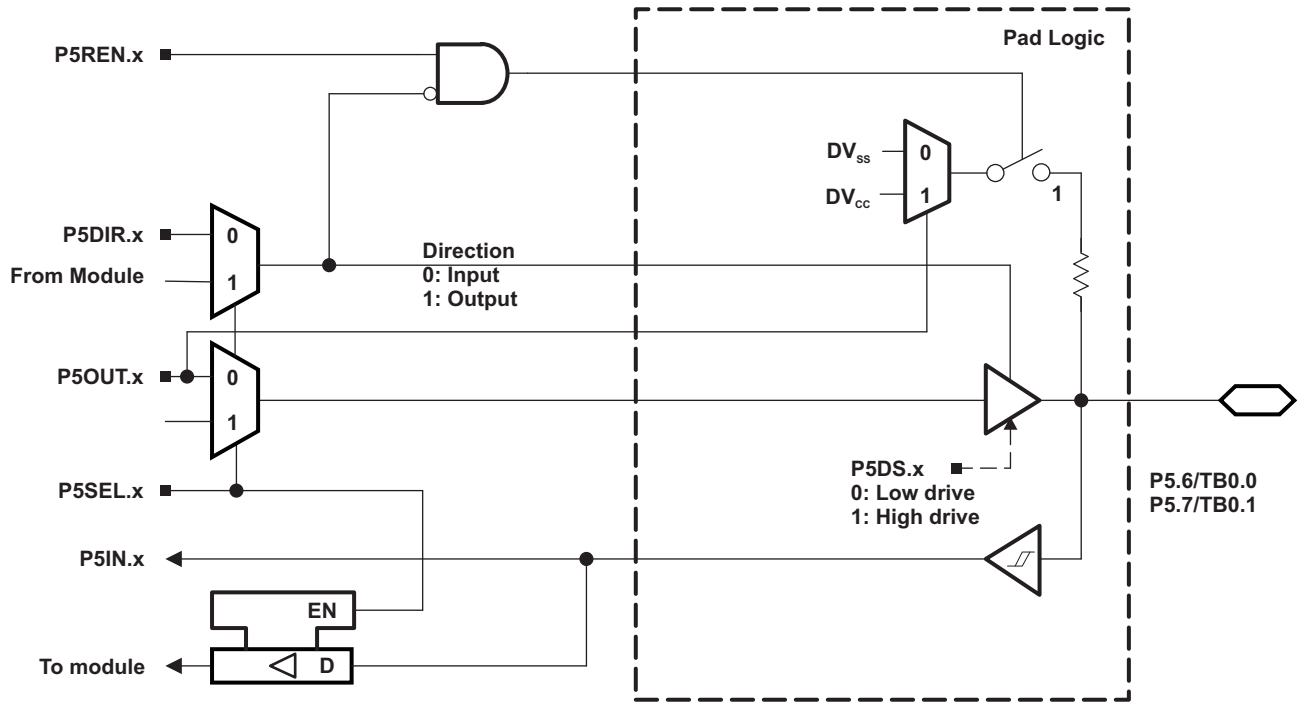

Table 52. Port P5 (P5.6 to P5.7) Pin Functions

| PIN NAME (P5.x) | x | FUNCTION | CONTROL BITS/SIGNALS | |
|---------------------------|---|------------|----------------------|---------|
| | | | P5DIR.x | P5SEL.x |
| P5.6/TB0.0 ⁽¹⁾ | 6 | P5.6 (I/O) | I: 0; O: 1 | 0 |
| | | TB0.CCI0A | 0 | 1 |
| | | TB0.0 | 1 | 1 |
| P5.7/TB0.1 ⁽¹⁾ | 7 | TB0.CCI1A | 0 | 1 |
| | | TB0.1 | 1 | 1 |

(1) F5329, F5327, F5325 devices only.

Port P6, P6.0 to P6.7, Input/Output With Schmitt Trigger

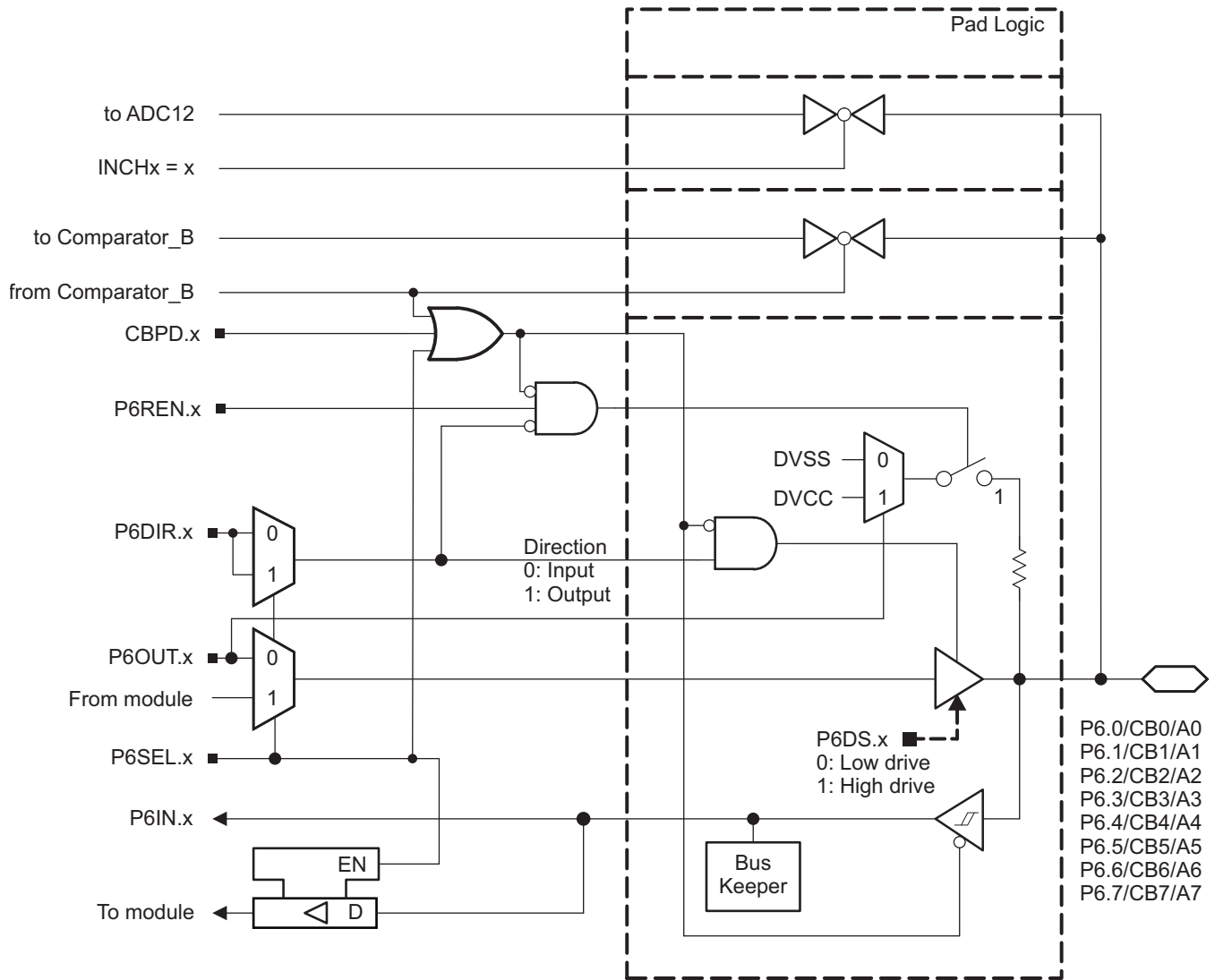

Table 53. Port P6 (P6.0 to P6.7) Pin Functions

| PIN NAME (P6.x) | x | FUNCTION | CONTROL BITS/SIGNALS | | |
|-----------------|---|--------------------|----------------------|---------|------|
| | | | P6DIR.x | P6SEL.x | CBPD |
| P6.0/CB0/(A0) | 0 | P6.0 (I/O) | I: 0; O: 1 | 0 | 0 |
| | | A0 | X | 1 | X |
| | | CB0 ⁽¹⁾ | X | X | 1 |
| P6.1/CB1/(A1) | 1 | P6.1 (I/O) | I: 0; O: 1 | 0 | 0 |
| | | A1 | X | 1 | X |
| | | CB1 ⁽¹⁾ | X | X | 1 |
| P6.2/CB2/(A2) | 2 | P6.2 (I/O) | I: 0; O: 1 | 0 | 0 |
| | | A2 | X | 1 | X |
| | | CB2 ⁽¹⁾ | X | X | 1 |
| P6.3/CB3/(A3) | 3 | P6.3 (I/O) | I: 0; O: 1 | 0 | 0 |
| | | A3 | X | 1 | X |
| | | CB3 ⁽¹⁾ | X | X | 1 |
| P6.4/CB4/(A4) | 4 | P6.4 (I/O) | I: 0; O: 1 | 0 | 0 |
| | | A4 | X | 1 | X |
| | | CB4 ⁽¹⁾ | X | X | 1 |
| P6.5/CB5/(A5) | 5 | P6.5 (I/O) | I: 0; O: 1 | 0 | 0 |
| | | A5 | X | 1 | X |
| | | CB5 ⁽¹⁾ | X | X | 1 |
| P6.6/CB6/(A6) | 6 | P6.6 (I/O) | I: 0; O: 1 | 0 | 0 |
| | | A6 | X | 1 | X |
| | | CB6 ⁽¹⁾ | X | X | 1 |
| P6.7/CB7/(A7) | 7 | P6.7 (I/O) | I: 0; O: 1 | 0 | 0 |
| | | A7 | X | 1 | X |
| | | CB7 ⁽¹⁾ | X | X | 1 |

- (1) Setting the CBPD.x bit disables the output driver as well as the input Schmitt trigger to prevent parasitic cross currents when applying analog signals. Selecting the CBx input pin to the comparator multiplexer with the CBx bits automatically disables output driver and input buffer for that pin, regardless of the state of the associated CBPD.x bit.

Port P7, P7.0 to P7.3, Input/Output With Schmitt Trigger

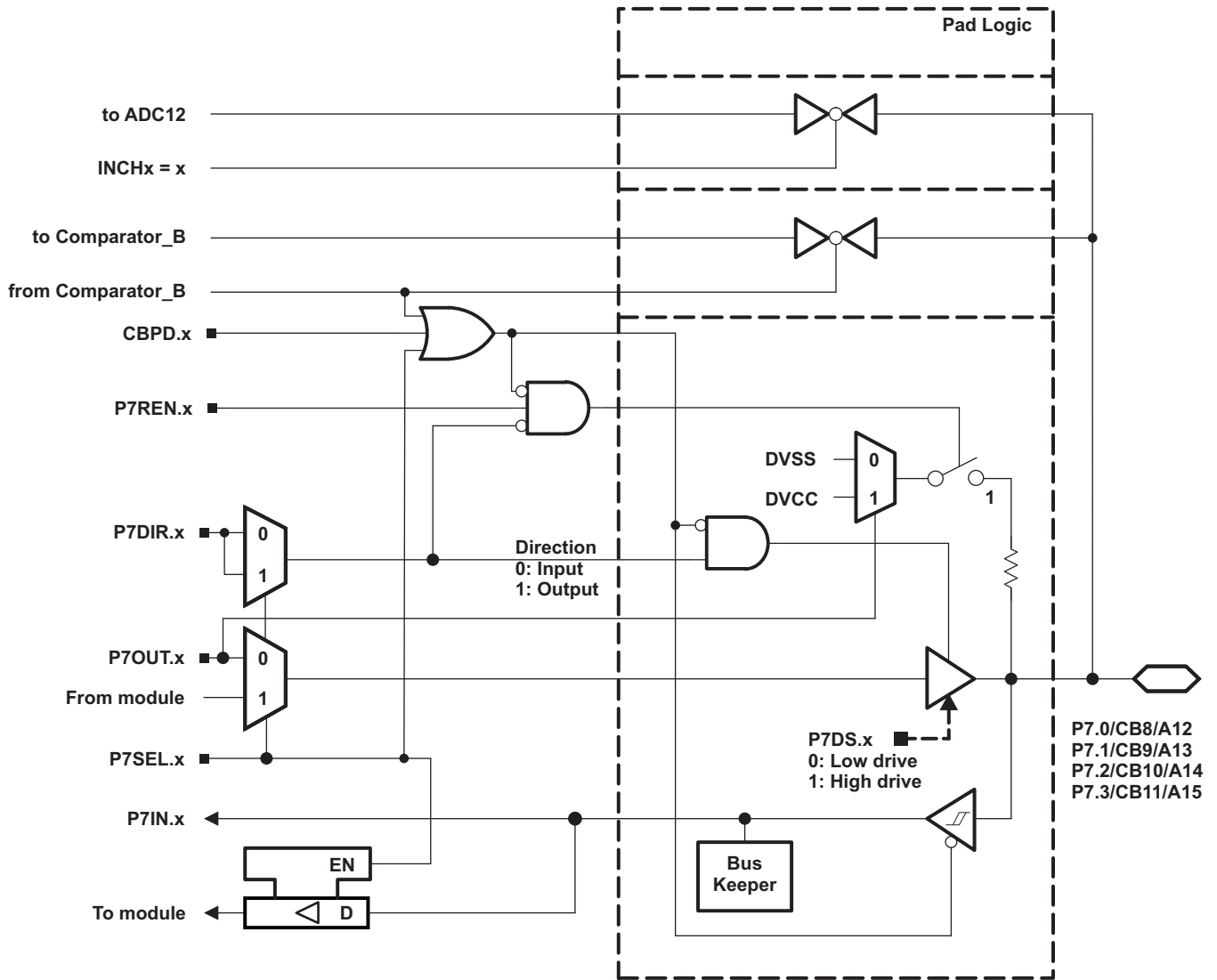

Table 54. Port P7 (P7.0 to P7.3) Pin Functions

| PIN NAME (P7.x) | x | FUNCTION | CONTROL BITS/SIGNALS | | |
|-----------------|---|---------------------------|----------------------|---------|------|
| | | | P7DIR.x | P7SEL.x | CBPD |
| P7.0/CB8/(A12) | 0 | P7.0 (I/O) ⁽¹⁾ | I: 0; O: 1 | 0 | 0 |
| | | A12 ⁽²⁾ | X | 1 | X |
| | | CB8 ⁽³⁾ (1) | X | X | 1 |
| P7.1/CB9/(A13) | 1 | P7.1 (I/O) ⁽¹⁾ | I: 0; O: 1 | 0 | 0 |
| | | A13 ⁽²⁾ | X | 1 | X |
| | | CB9 ⁽³⁾ (1) | X | X | 1 |
| P7.2/CB10/(A14) | 2 | P7.2 (I/O) ⁽¹⁾ | I: 0; O: 1 | 0 | 0 |
| | | A14 ⁽²⁾ | X | 1 | X |
| | | CB10 ⁽³⁾ (1) | X | X | 1 |
| P7.3/CB11/(A15) | 3 | P7.3 (I/O) ⁽¹⁾ | I: 0; O: 1 | 0 | 0 |
| | | A15 ⁽²⁾ | X | 1 | X |
| | | CB11 ⁽³⁾ (1) | X | X | 1 |

(1) F5329, F5327, F5325 devices only.

(2) F5329, F5327, F5325 devices only.

(3) Setting the CBPD.x bit disables the output driver as well as the input Schmitt trigger to prevent parasitic cross currents when applying analog signals. Selecting the CBx input pin to the comparator multiplexer with the CBx bits automatically disables output driver and input buffer for that pin, regardless of the state of the associated CBPD.x bit.

Port P7, P7.4 to P7.7, Input/Output With Schmitt Trigger

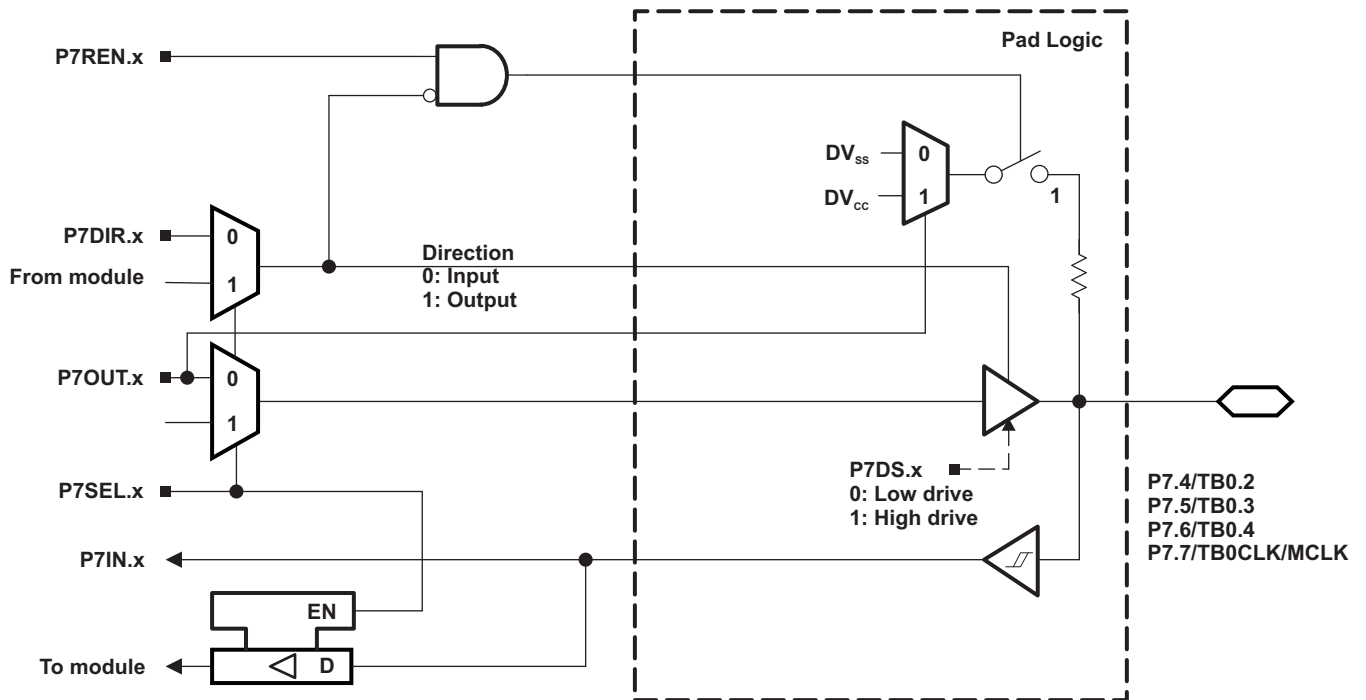

Table 55. Port P7 (P7.4 to P7.7) Pin Functions

| PIN NAME (P7.x) | x | FUNCTION | CONTROL BITS/SIGNALS | |
|---------------------------------|---|------------|----------------------|---------|
| | | | P7DIR.x | P7SEL.x |
| P7.4/TB0.2 ⁽¹⁾ | 4 | P7.4 (I/O) | I: 0; O: 1 | 0 |
| | | TB0.CCI2A | 0 | 1 |
| | | TB0.2 | 1 | 1 |
| P7.5/TB0.3 ⁽¹⁾ | 5 | P7.5 (I/O) | I: 0; O: 1 | 0 |
| | | TB0.CCI3A | 0 | 1 |
| | | TB0.3 | 1 | 1 |
| P7.6/TB0.4 ⁽¹⁾ | 6 | P7.6 (I/O) | I: 0; O: 1 | 0 |
| | | TB0.CCI4A | 0 | 1 |
| | | TB0.4 | 1 | 1 |
| P7.7/TB0CLK/MCLK ⁽¹⁾ | 7 | P7.7 (I/O) | I: 0; O: 1 | 0 |
| | | TB0CLK | 0 | 1 |
| | | MCLK | 1 | 1 |

(1) F5329, F5327, F5325 devices only.

Port P8, P8.0 to P8.2, Input/Output With Schmitt Trigger

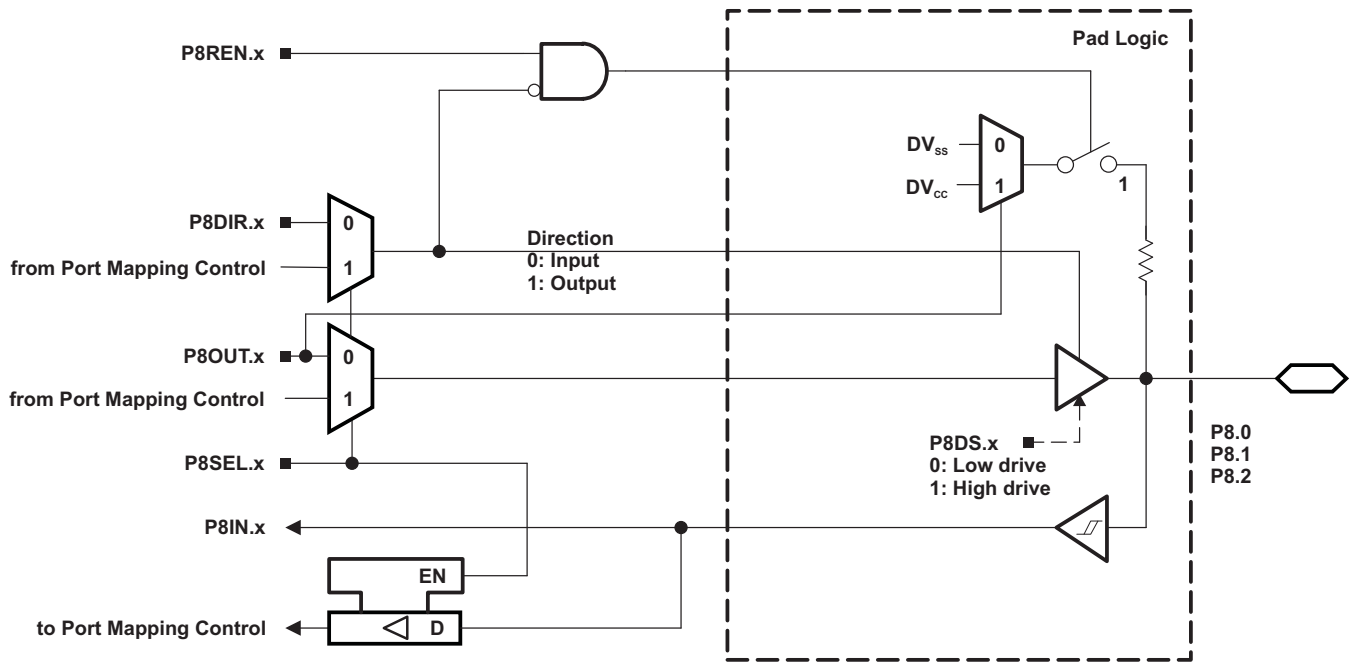

Table 56. Port P8 (P8.0 to P8.2) Pin Functions

| PIN NAME (P8.x) | x | FUNCTION | CONTROL BITS/SIGNALS | |
|---------------------|---|-----------|----------------------|---------|
| | | | P8DIR.x | P8SEL.x |
| P8.0 ⁽¹⁾ | 0 | P8.0(I/O) | I: 0; O: 1 | 0 |
| P8.1 ⁽¹⁾ | 1 | P8.1(I/O) | I: 0; O: 1 | 0 |
| P8.2 ⁽¹⁾ | 2 | P8.2(I/O) | I: 0; O: 1 | 0 |

(1) F5329, F5327, F5325 devices only.

Port PU.0, PU.1 Ports

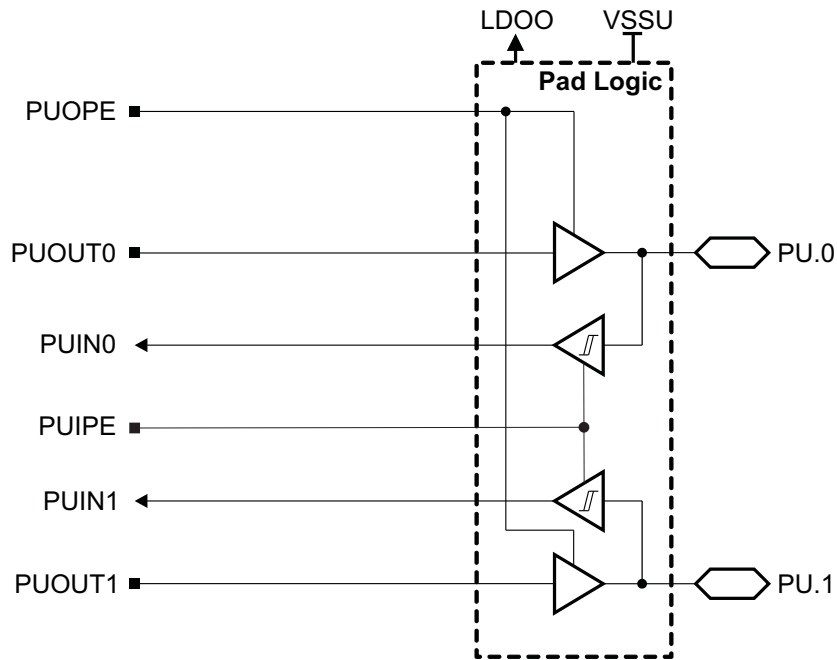

Table 57. Port PU.0, PU.1 Output Functions⁽¹⁾

| CONTROL BITS | | | PIN NAME | |
|--------------|--------|--------|-----------------|-----------------|
| PUOPE | PUOUT1 | PUOUT0 | PU.1/DM | PU.0/DP |
| 0 | X | X | Output disabled | Output disabled |
| 1 | 0 | 0 | Output low | Output low |
| 1 | 0 | 1 | Output low | Output high |
| 1 | 1 | 0 | Output high | Output low |
| 1 | 1 | 1 | Output high | Output high |

(1) PU.1 and PU.0 inputs and outputs are supplied from LDOO. LDOO can be generated by the device using the integrated 3.3V LDO when enabled. LDOO can also be supplied externally when the 3.3V LDO is not being used and is disabled.

Table 58. Port PU.0, PU.1 Input Functions⁽¹⁾

| CONTROL BITS | PIN NAME | |
|--------------|----------------|----------------|
| PUIPE | PU.1/DM | PU.0/DP |
| 0 | Input disabled | Input disabled |
| 1 | Input enabled | Input enabled |

(1) PU.1 and PU.0 inputs and outputs are supplied from LDOO. LDOO can be generated by the device using the integrated 3.3V LDO when enabled. LDOO can also be supplied externally when the 3.3V LDO is not being used and is disabled.

Port J, J.0 JTAG pin TDO, Input/Output With Schmitt Trigger or Output

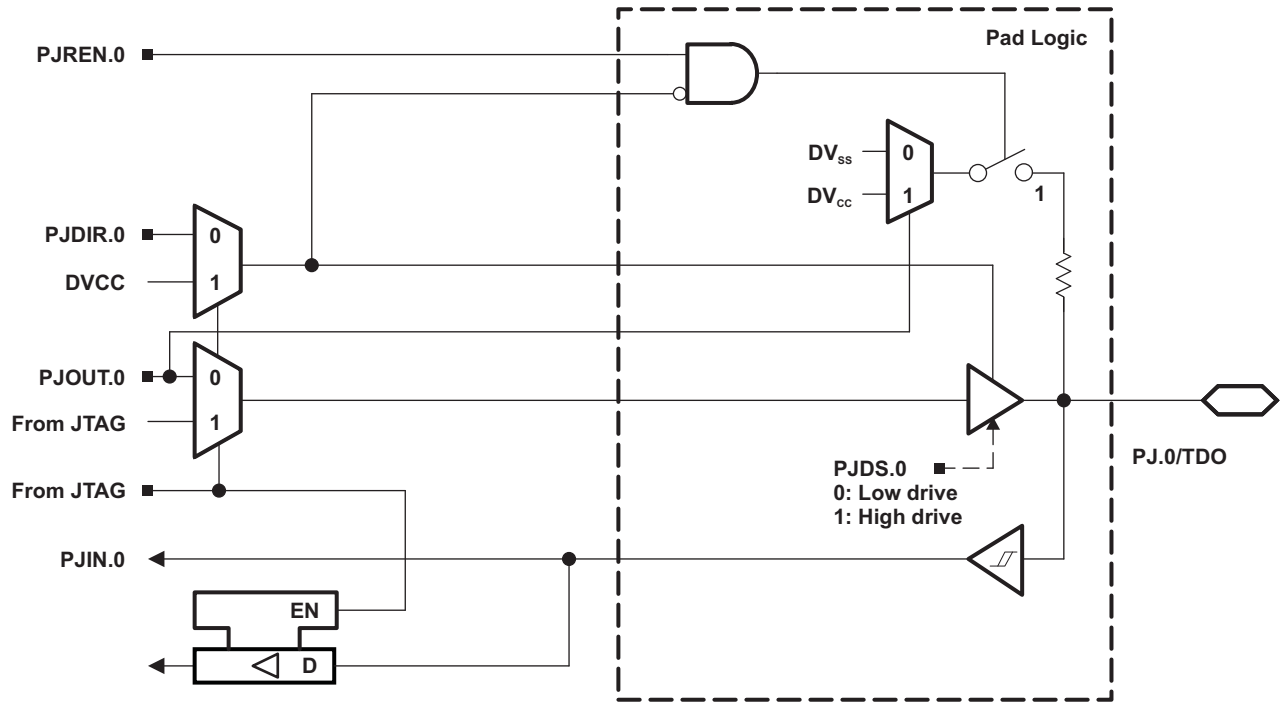

Port J, J.1 to J.3 JTAG pins TMS, TCK, TDI/TCLK, Input/Output With Schmitt Trigger or Output

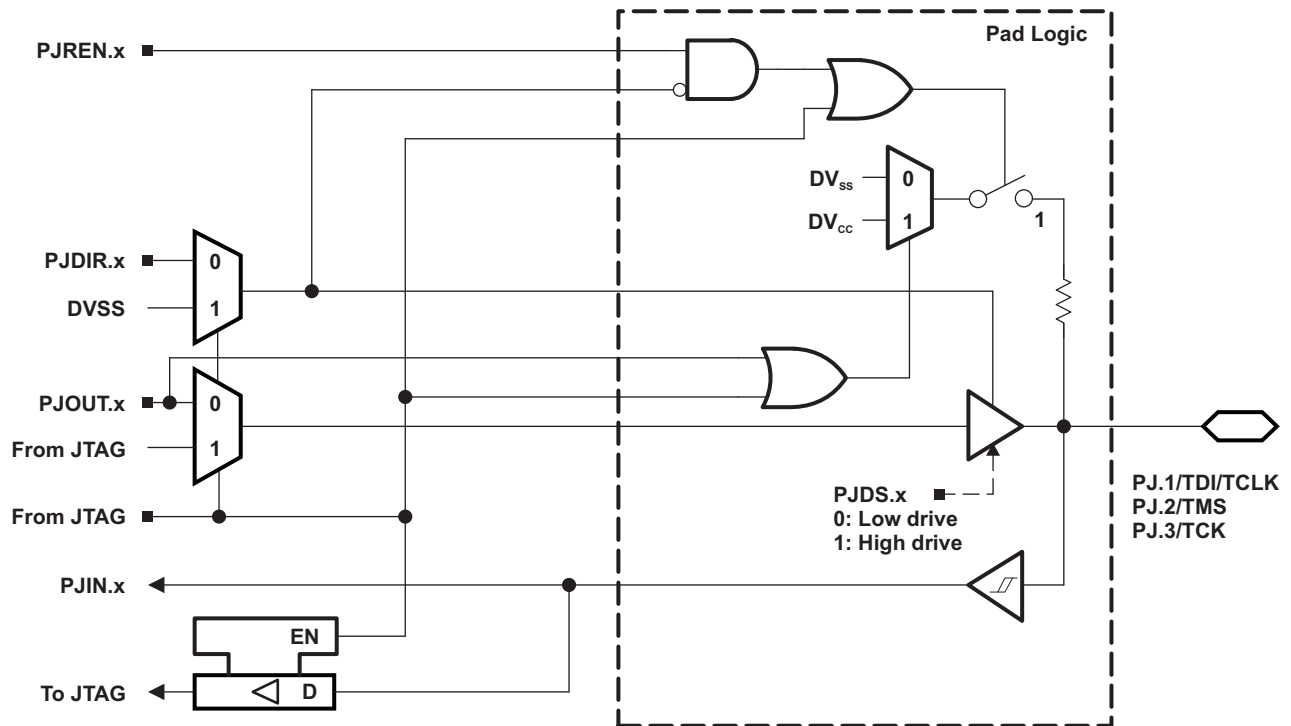

Table 59. Port PJ (PJ.0 to PJ.3) Pin Functions

| PIN NAME (PJ.x) | x | FUNCTION | CONTROL BITS/ SIGNALS ⁽¹⁾ |
|-----------------|---|-----------------------------|---|
| | | | PJDIR.x |
| PJ.0/TDO | 0 | PJ.0 (I/O) ⁽²⁾ | I: 0; O: 1 |
| | | TDO ⁽³⁾ | X |
| PJ.1/TDI/TCLK | 1 | PJ.1 (I/O) ⁽²⁾ | I: 0; O: 1 |
| | | TDI/TCLK ^{(3) (4)} | X |
| PJ.2/TMS | 2 | PJ.2 (I/O) ⁽²⁾ | I: 0; O: 1 |
| | | TMS ^{(3) (4)} | X |
| PJ.3/TCK | 3 | PJ.3 (I/O) ⁽²⁾ | I: 0; O: 1 |
| | | TCK ^{(3) (4)} | X |

(1) X = Don't care

(2) Default condition

(3) The pin direction is controlled by the JTAG module.

(4) In JTAG mode, pullups are activated automatically on TMS, TCK, and TDI/TCLK. PJREN.x are don't care.

DEVICE DESCRIPTORS

Table 60 lists the complete contents of the device descriptor tag-length-value (TLV) structure for each device type.

Table 60. F532x Device Descriptor Table⁽¹⁾

| | Description | Address | Size bytes | F5329 | F5328 | F5327 | F5326 | F5325 | F5324 |
|------------------------------|--|---------|------------|------------|------------|------------|------------|------------|------------|
| | | | | Value | Value | Value | Value | Value | Value |
| Info Block | Info length | 01A00h | 1 | 06h | 06h | 06h | 06h | 06h | 06h |
| | CRC length | 01A01h | 1 | 06h | 06h | 06h | 06h | 06h | 06h |
| | CRC value | 01A02h | 2 | per unit | per unit | per unit | per unit | per unit | per unit |
| | Device ID | 01A04h | 1 | 1Bh | 1Ah | 19h | 18h | 17h | 16h |
| | Device ID | 01A05h | 1 | 81h | 81h | 81h | 81h | 81h | 81h |
| | Hardware revision | 01A06h | 1 | per unit | per unit | per unit | per unit | per unit | per unit |
| | Firmware revision | 01A07h | 1 | per unit | per unit | per unit | per unit | per unit | per unit |
| Die Record | Die Record Tag | 01A08h | 1 | 08h | 08h | 08h | 08h | 08h | 08h |
| | Die Record length | 01A09h | 1 | 0Ah | 0Ah | 0Ah | 0Ah | 0Ah | 0Ah |
| | Lot/Wafer ID | 01A0Ah | 4 | per unit | per unit | per unit | per unit | per unit | per unit |
| | Die X position | 01A0Eh | 2 | per unit | per unit | per unit | per unit | per unit | per unit |
| | Die Y position | 01A10h | 2 | per unit | per unit | per unit | per unit | per unit | per unit |
| | Test results | 01A12h | 2 | per unit | per unit | per unit | per unit | per unit | per unit |
| ADC12 Calibration | ADC12 Calibration Tag | 01A14h | 1 | 11h | 11h | 11h | 11h | 11h | 11h |
| | ADC12 Calibration length | 01A15h | 1 | 10h | 10h | 10h | 10h | 10h | 10h |
| | ADC Gain Factor | 01A16h | 2 | per unit | per unit | per unit | per unit | per unit | per unit |
| | ADC Offset | 01A18h | 2 | per unit | per unit | per unit | per unit | per unit | per unit |
| | ADC 1.5-V Reference Temp. Sensor 30°C | 01A1Ah | 2 | per unit | per unit | per unit | per unit | per unit | per unit |
| | ADC 1.5-V Reference Temp. Sensor 105°C | 01A1Ch | 2 | per unit | per unit | per unit | per unit | per unit | per unit |
| | ADC 2.0-V Reference Temp. Sensor 30°C | 01A1Eh | 2 | per unit | per unit | per unit | per unit | per unit | per unit |
| | ADC 2.0-V Reference Temp. Sensor 85°C | 01A20h | 2 | per unit | per unit | per unit | per unit | per unit | per unit |
| | ADC 2.5-V Reference Temp. Sensor 30°C | 01A22h | 2 | per unit | per unit | per unit | per unit | per unit | per unit |
| | ADC 2.5-V Reference Temp. Sensor 85°C | 01A24h | 2 | per unit | per unit | per unit | per unit | per unit | per unit |
| REF Calibration | REF Calibration Tag | 01A26h | 1 | 12h | 12h | 12h | 12h | 12h | 12h |
| | REF Calibration length | 01A27h | 1 | 06h | 06h | 06h | 06h | 06h | 06h |
| | REF 1.5-V Reference Factor | 01A28h | 2 | per unit | per unit | per unit | per unit | per unit | per unit |
| | REF 2.0-V Reference Factor | 01A2Ah | 2 | per unit | per unit | per unit | per unit | per unit | per unit |
| | REF 2.5-V Reference Factor | 01A2Ch | 2 | per unit | per unit | per unit | per unit | per unit | per unit |
| Peripheral Descriptor | Peripheral Descriptor Tag | 01A2Eh | 1 | 02h | 02h | 02h | 02h | 02h | 02h |
| | Peripheral Descriptor Length | 01A2Fh | 1 | 62h | 60h | 62h | 60h | 62h | 60h |
| | Memory 1 | | 2 | 08h 8Ah | 08h 8Ah | 08h 8Ah | 08h 8Ah | 08h 8Ah | 08h 8Ah |

(1) NA = Not applicable, blank = unused and reads FFh.

Table 60. F532x Device Descriptor Table⁽¹⁾ (continued)

| | Description | Address | Size bytes | F5329 | F5328 | F5327 | F5326 | F5325 | F5324 |
|--|------------------|---------|---------------|------------|------------|------------|------------|------------|------------|
| | | | | Value | Value | Value | Value | Value | Value |
| | Memory 2 | | 2 | 0Ch 86h | 0Ch 86h | 0Ch 86h | 0Ch 86h | 0Ch 86h | 0Ch 86h |
| | Memory 3 | | 2 | 0Eh 2Fh | 0Eh 2Fh | 0Eh 2Eh | 0Eh 2Eh | 0Eh 2Dh | 0Eh 2Dh |
| | Memory 4 | | 2 | 2Ah 22h | 2Ah 22h | 22h 95h | 22h 95h | 2Ah 22h | 2Ah 22h |
| | Memory 5 | | 1 | 96h | 96h | 92h | 92h | 94h | 94h |
| | delimiter | | 1 | 00h | 00h | 00h | 00h | 00h | 00h |
| | Peripheral count | | 1 | 21h | 20h | 21h | 20h | 21h | 20h |
| | MSP430CPUXV2 | | 2 | 00h 23h | 00h 23h | 00h 23h | 00h 23h | 00h 23h | 00h 23h |
| | JTAG | | 2 | 00h 09h | 00h 09h | 00h 09h | 00h 09h | 00h 09h | 00h 09h |
| | SBW | | 2 | 00h 0Fh | 00h 0Fh | 00h 0Fh | 00h 0Fh | 00h 0Fh | 00h 0Fh |
| | EEM-L | | 2 | 00h 05h | 00h 05h | 00h 05h | 00h 05h | 00h 05h | 00h 05h |
| | TI BSL | | 2 | 00h FCh | 00h FCh | 00h FCh | 00h FCh | 00h FCh | 00h FCh |
| | SFR | | 2 | 10h 41h | 10h 41h | 10h 41h | 10h 41h | 10h 41h | 10h 41h |
| | PMM | | 2 | 02h 30h | 02h 30h | 02h 30h | 02h 30h | 02h 30h | 02h 30h |
| | FCTL | | 2 | 02h 38h | 02h 38h | 02h 38h | 02h 38h | 02h 38h | 02h 38h |
| | CRC16 | | 2 | 01h 3Ch | 01h 3Ch | 01h 3Ch | 01h 3Ch | 01h 3Ch | 01h 3Ch |
| | CRC16_RB | | 2 | 00h 3Dh | 00h 3Dh | 00h 3Dh | 00h 3Dh | 00h 3Dh | 00h 3Dh |
| | RAMCTL | | 2 | 00h 44h | 00h 44h | 00h 44h | 00h 44h | 00h 44h | 00h 44h |
| | WDT_A | | 2 | 00h 40h | 00h 40h | 00h 40h | 00h 40h | 00h 40h | 00h 40h |
| | UCS | | 2 | 01h 48h | 01h 48h | 01h 48h | 01h 48h | 01h 48h | 01h 48h |
| | SYS | | 2 | 02h 42h | 02h 42h | 02h 42h | 02h 42h | 02h 42h | 02h 42h |
| | REF | | 2 | 03h A0h | 03h A0h | 03h A0h | 03h A0h | 03h A0h | 03h A0h |
| | Port Mapping | | 2 | 01h 10h | 01h 10h | 01h 10h | 01h 10h | 01h 10h | 01h 10h |
| | Port 1/2 | | 2 | 04h 51h | 04h 51h | 04h 51h | 04h 51h | 04h 51h | 04h 51h |
| | Port 3/4 | | 2 | 02h 52h | 02h 52h | 02h 52h | 02h 52h | 02h 52h | 02h 52h |
| | Port 5/6 | | 2 | 02h 53h | 02h 53h | 02h 53h | 02h 53h | 02h 53h | 02h 53h |
| | Port 7/8 | | 2 | 02h 54h | N/A | 02h 54h | N/A | 02h 54h | N/A |
| | JTAG | | 2 | 0Ch 5Fh | 0Eh 5Fh | 0Ch 5Fh | 0Eh 5Fh | 0Ch 5Fh | 0Eh 5Fh |
| | TA0 | | 2 | 02h 62h | 02h 62h | 02h 62h | 02h 62h | 02h 62h | 02h 62h |

Table 60. F532x Device Descriptor Table⁽¹⁾ (continued)

| | Description | Address | Size bytes | F5329 | F5328 | F5327 | F5326 | F5325 | F5324 |
|-------------------|---------------|---------|---------------|------------|------------|------------|------------|------------|------------|
| | | | | Value | Value | Value | Value | Value | Value |
| | TA1 | | 2 | 04h 61h | 04h 61h | 04h 61h | 04h 61h | 04h 61h | 04h 61h |
| | TB0 | | 2 | 04h 67h | 04h 67h | 04h 67h | 04h 67h | 04h 67h | 04h 67h |
| | TA2 | | 2 | 04h 61h | 04h 61h | 04h 61h | 04h 61h | 04h 61h | 04h 61h |
| | RTC | | 2 | 0Ah 68h | 0Ah 68h | 0Ah 68h | 0Ah 68h | 0Ah 68h | 0Ah 68h |
| | MPY32 | | 2 | 02h 85h | 02h 85h | 02h 85h | 02h 85h | 02h 85h | 02h 85h |
| | DMA-3 | | 2 | 04h 47h | 04h 47h | 04h 47h | 04h 47h | 04h 47h | 04h 47h |
| | USCI_A/B | | 2 | 0Ch 90h | 0Ch 90h | 0Ch 90h | 0Ch 90h | 0Ch 90h | 0Ch 90h |
| | USCI_A/B | | 2 | 04h 90h | 04h 90h | 04h 90h | 04h 90h | 04h 90h | 04h 90h |
| | ADC12_A | | 2 | 10h D1h | 10h D1h | 10h D1h | 10h D1h | 10h D1h | 10h D1h |
| | COMP_B | | 2 | 1Ch A8h | 1Ch A8h | 1Ch A8h | 1Ch A8h | 1Ch A8h | 1Ch A8h |
| | LDO | | 2 | 04h 5Ch | 04h 5Ch | 04h 5Ch | 04h 5Ch | 04h 5Ch | 04h 5Ch |
| Interrupts | COMP_B | | 1 | A8h | A8h | A8h | A8h | A8h | A8h |
| | TB0.CCIFG0 | | 1 | 64h | 64h | 64h | 64h | 64h | 64h |
| | TB0.CCIFG1..6 | | 1 | 65h | 65h | 65h | 65h | 65h | 65h |
| | WDTIFG | | 1 | 40h | 40h | 40h | 40h | 40h | 40h |
| | USCI_A0 | | 1 | 90h | 90h | 90h | 90h | 90h | 90h |
| | USCI_B0 | | 1 | 91h | 91h | 91h | 91h | 91h | 91h |
| | ADC12_A | | 1 | D0h | D0h | D0h | D0h | D0h | D0h |
| | TA0.CCIFG0 | | 1 | 60h | 60h | 60h | 60h | 60h | 60h |
| | TA0.CCIFG1..4 | | 1 | 61h | 61h | 61h | 61h | 61h | 61h |
| | LDO-PWR | | 1 | 5Ch | 5Ch | 5Ch | 5Ch | 5Ch | 5Ch |
| | DMA | | 1 | 46h | 46h | 46h | 46h | 46h | 46h |
| | TA1.CCIFG0 | | 1 | 62h | 62h | 62h | 62h | 62h | 62h |
| | TA1.CCIFG1..2 | | 1 | 63h | 63h | 63h | 63h | 63h | 63h |
| | P1 | | 1 | 50h | 50h | 50h | 50h | 50h | 50h |
| | USCI_A1 | | 1 | 92h | 92h | 92h | 92h | 92h | 92h |
| | USCI_B1 | | 1 | 93h | 93h | 93h | 93h | 93h | 93h |
| | TA1.CCIFG0 | | 1 | 66h | 66h | 66h | 66h | 66h | 66h |
| | TA1.CCIFG1..2 | | 1 | 67h | 67h | 67h | 67h | 67h | 67h |
| | P2 | | 1 | 51h | 51h | 51h | 51h | 51h | 51h |
| | RTC_A | | 1 | 68h | 68h | 68h | 68h | 68h | 68h |
| | delimiter | | 1 | 00h | 00h | 00h | 00h | 00h | 00h |

PACKAGING INFORMATION

| Orderable Device | Status (1) | Package Type | Package Drawing | Pins | Package Qty | Eco Plan (2) | Lead/Ball Finish (6) | MSL Peak Temp (3) | Op Temp (°C) | Device Marking (4/5) | Samples |
|--------------------|---------------|--------------|-----------------|------|-------------|-------------------------|-------------------------|----------------------|--------------|-------------------------|-------------------------|
| MSP430F5328TRGCTEP | ACTIVE | VQFN | RGC | 64 | 250 | Green (RoHS & no Sb/Br) | CU NIPDAU | Level-3-260C-168 HR | -40 to 105 | M4F5328T | Samples |
| V62/13628-01XE | ACTIVE | VQFN | RGC | 64 | 250 | Green (RoHS & no Sb/Br) | CU NIPDAU | Level-3-260C-168 HR | -40 to 105 | M4F5328T | Samples |

(1) The marketing status values are defined as follows:

ACTIVE: Product device recommended for new designs.

LIFEBUY: TI has announced that the device will be discontinued, and a lifetime-buy period is in effect.

NRND: Not recommended for new designs. Device is in production to support existing customers, but TI does not recommend using this part in a new design.

PREVIEW: Device has been announced but is not in production. Samples may or may not be available.

OBSOLETE: TI has discontinued the production of the device.

(2) Eco Plan - The planned eco-friendly classification: Pb-Free (RoHS), Pb-Free (RoHS Exempt), or Green (RoHS & no Sb/Br) - please check <http://www.ti.com/productcontent> for the latest availability information and additional product content details.

TBD: The Pb-Free/Green conversion plan has not been defined.

Pb-Free (RoHS): TI's terms "Lead-Free" or "Pb-Free" mean semiconductor products that are compatible with the current RoHS requirements for all 6 substances, including the requirement that lead not exceed 0.1% by weight in homogeneous materials. Where designed to be soldered at high temperatures, TI Pb-Free products are suitable for use in specified lead-free processes.

Pb-Free (RoHS Exempt): This component has a RoHS exemption for either 1) lead-based flip-chip solder bumps used between the die and package, or 2) lead-based die adhesive used between the die and leadframe. The component is otherwise considered Pb-Free (RoHS compatible) as defined above.

Green (RoHS & no Sb/Br): TI defines "Green" to mean Pb-Free (RoHS compatible), and free of Bromine (Br) and Antimony (Sb) based flame retardants (Br or Sb do not exceed 0.1% by weight in homogeneous material)

(3) MSL, Peak Temp. - The Moisture Sensitivity Level rating according to the JEDEC industry standard classifications, and peak solder temperature.

(4) There may be additional marking, which relates to the logo, the lot trace code information, or the environmental category on the device.

(5) Multiple Device Markings will be inside parentheses. Only one Device Marking contained in parentheses and separated by a "~" will appear on a device. If a line is indented then it is a continuation of the previous line and the two combined represent the entire Device Marking for that device.

(6) Lead/Ball Finish - Orderable Devices may have multiple material finish options. Finish options are separated by a vertical ruled line. Lead/Ball Finish values may wrap to two lines if the finish value exceeds the maximum column width.

Important Information and Disclaimer: The information provided on this page represents TI's knowledge and belief as of the date that it is provided. TI bases its knowledge and belief on information provided by third parties, and makes no representation or warranty as to the accuracy of such information. Efforts are underway to better integrate information from third parties. TI has taken and continues to take reasonable steps to provide representative and accurate information but may not have conducted destructive testing or chemical analysis on incoming materials and chemicals. TI and TI suppliers consider certain information to be proprietary, and thus CAS numbers and other limited information may not be available for release.

In no event shall TI's liability arising out of such information exceed the total purchase price of the TI part(s) at issue in this document sold by TI to Customer on an annual basis.

OTHER QUALIFIED VERSIONS OF MSP430F5328-EP :

- Catalog: [MSP430F5328](#)

NOTE: Qualified Version Definitions:

- Catalog - TI's standard catalog product

TAPE AND REEL INFORMATION

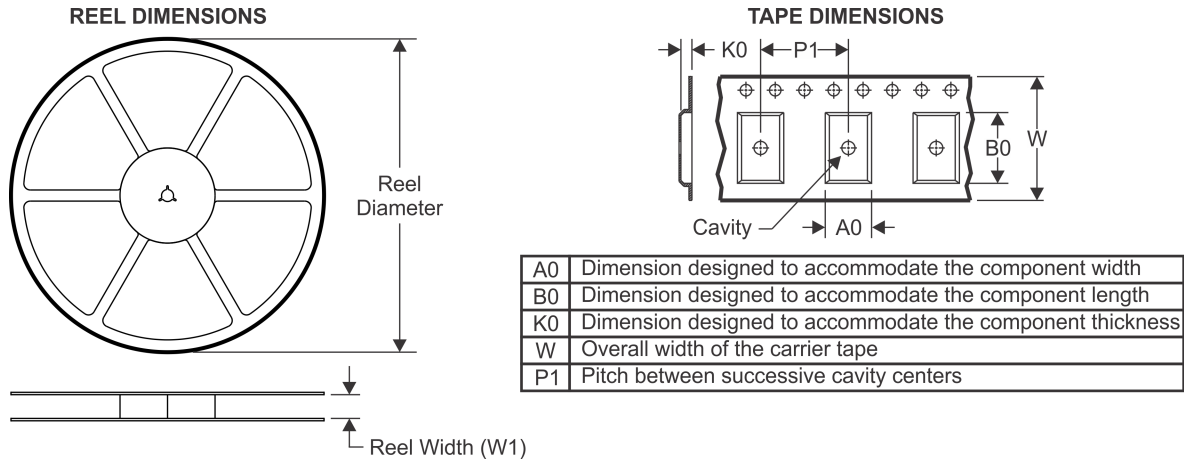

QUADRANT ASSIGNMENTS FOR PIN 1 ORIENTATION IN TAPE

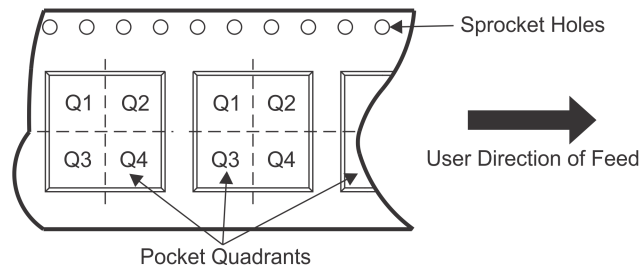

*All dimensions are nominal

| Device | Package Type | Package Drawing | Pins | SPQ | Reel Diameter (mm) | Reel Width W1 (mm) | A0 (mm) | B0 (mm) | K0 (mm) | P1 (mm) | W (mm) | Pin1 Quadrant |
|--------------------|--------------|-----------------|------|-----|--------------------|--------------------|---------|---------|---------|---------|--------|---------------|
| MSP430F5328TRGCTEP | VQFN | RGC | 64 | 250 | 180.0 | 16.4 | 9.3 | 9.3 | 1.5 | 12.0 | 16.0 | Q2 |

TAPE AND REEL BOX DIMENSIONS

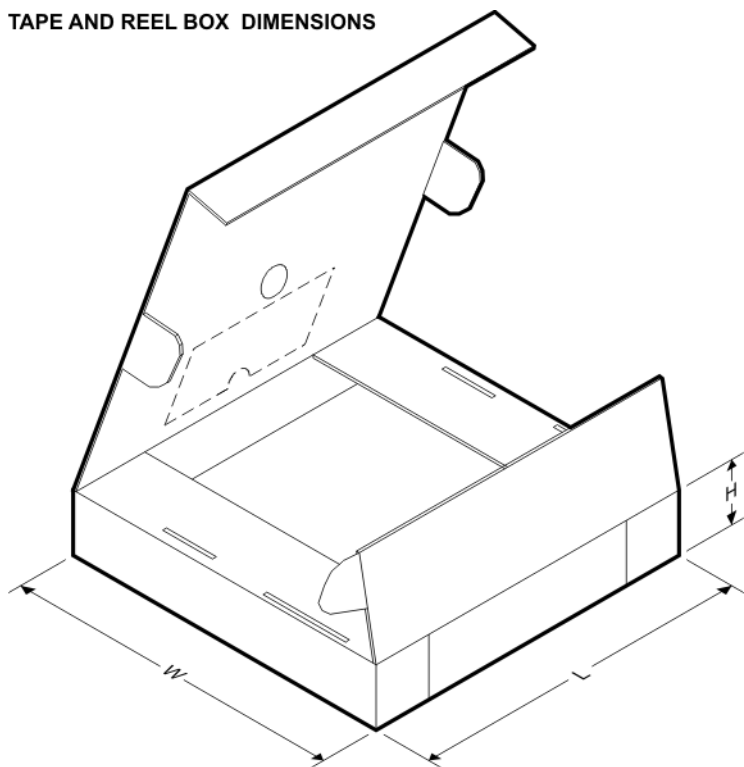

*All dimensions are nominal

| Device | Package Type | Package Drawing | Pins | SPQ | Length (mm) | Width (mm) | Height (mm) |
|--------------------|--------------|-----------------|------|-----|-------------|------------|-------------|
| MSP430F5328TRGCTEP | VQFN | RGC | 64 | 250 | 210.0 | 185.0 | 35.0 |

GENERIC PACKAGE VIEW

RGC 64

VQFN - 1 mm max height

9 x 9, 0.5 mm pitch

PLASTIC QUAD FLATPACK - NO LEAD

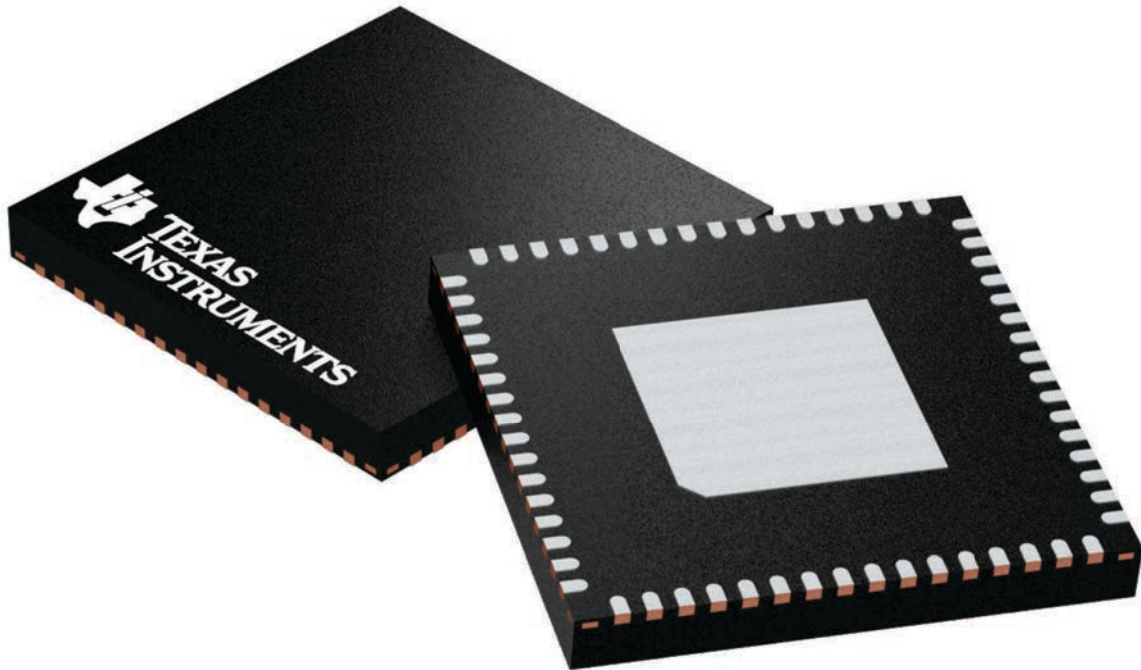

Images above are just a representation of the package family, actual package may vary.
Refer to the product data sheet for package details.

4224597/A

EXAMPLE BOARD LAYOUT

RGC0064B

VQFN - 1 mm max height

PLASTIC QUAD FLATPACK - NO LEAD

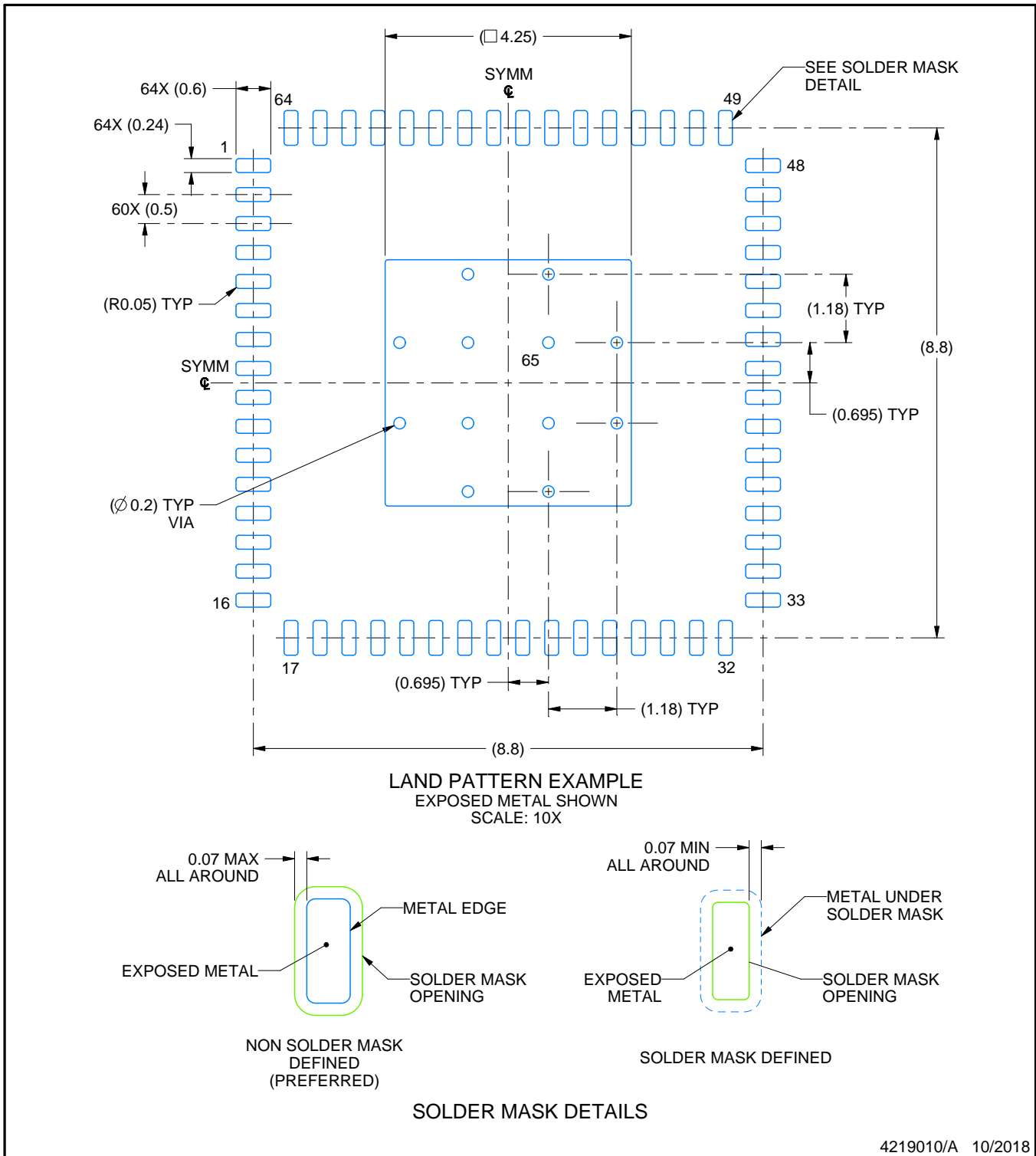

4219010/A 10/2018

NOTES: (continued)

4. This package is designed to be soldered to a thermal pad on the board. For more information, see Texas Instruments literature number SLUA271 (www.ti.com/lit/sluea271).
5. Vias are optional depending on application, refer to device data sheet. If any vias are implemented, refer to their locations shown on this view. It is recommended that vias under paste be filled, plugged or tented.

EXAMPLE STENCIL DESIGN

RGC0064B

VQFN - 1 mm max height

PLASTIC QUAD FLATPACK - NO LEAD

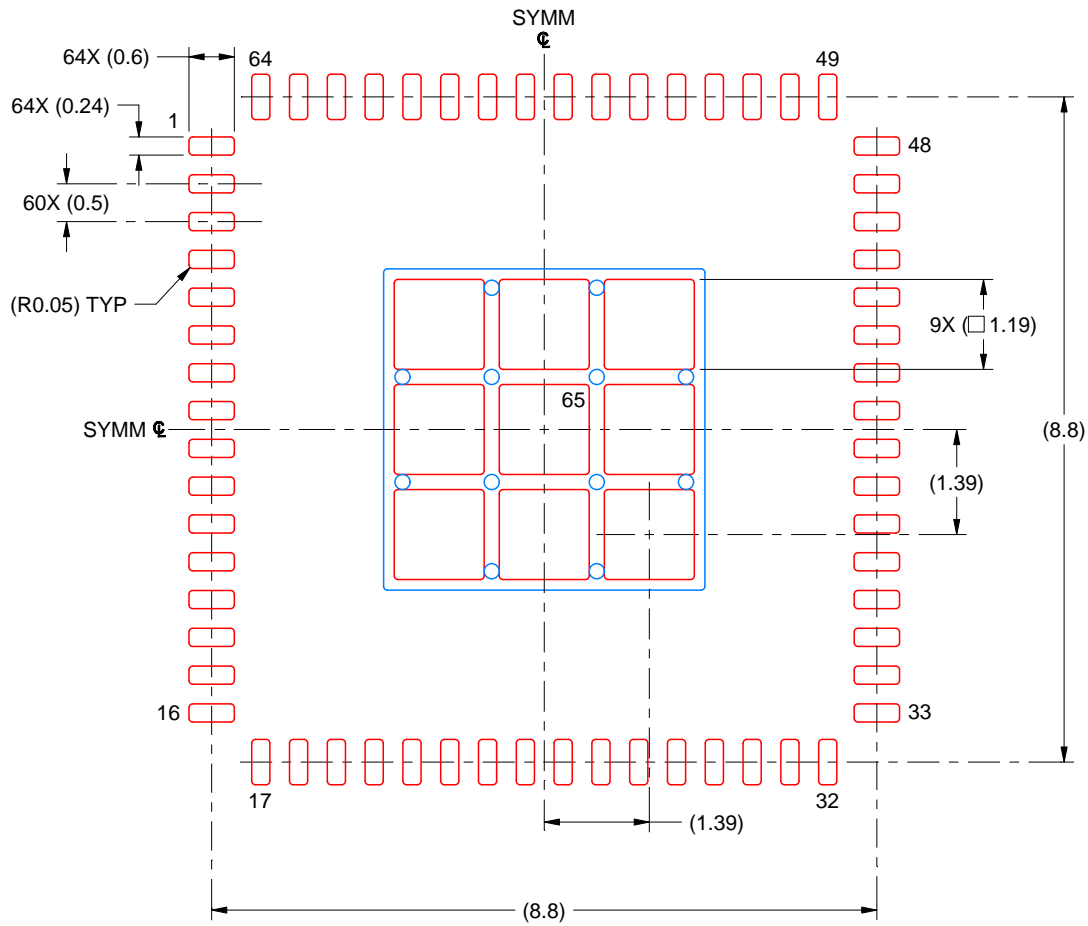

SOLDER PASTE EXAMPLE
 BASED ON 0.125 MM THICK STENCIL
 SCALE: 10X

EXPOSED PAD 65
 71% PRINTED SOLDER COVERAGE BY AREA UNDER PACKAGE

4219010/A 10/2018

NOTES: (continued)

6. Laser cutting apertures with trapezoidal walls and rounded corners may offer better paste release. IPC-7525 may have alternate design recommendations.

IMPORTANT NOTICE AND DISCLAIMER

TI PROVIDES TECHNICAL AND RELIABILITY DATA (INCLUDING DATASHEETS), DESIGN RESOURCES (INCLUDING REFERENCE DESIGNS), APPLICATION OR OTHER DESIGN ADVICE, WEB TOOLS, SAFETY INFORMATION, AND OTHER RESOURCES "AS IS" AND WITH ALL FAULTS, AND DISCLAIMS ALL WARRANTIES, EXPRESS AND IMPLIED, INCLUDING WITHOUT LIMITATION ANY IMPLIED WARRANTIES OF MERCHANTABILITY, FITNESS FOR A PARTICULAR PURPOSE OR NON-INFRINGEMENT OF THIRD PARTY INTELLECTUAL PROPERTY RIGHTS.

These resources are intended for skilled developers designing with TI products. You are solely responsible for (1) selecting the appropriate TI products for your application, (2) designing, validating and testing your application, and (3) ensuring your application meets applicable standards, and any other safety, security, or other requirements. These resources are subject to change without notice. TI grants you permission to use these resources only for development of an application that uses the TI products described in the resource. Other reproduction and display of these resources is prohibited. No license is granted to any other TI intellectual property right or to any third party intellectual property right. TI disclaims responsibility for, and you will fully indemnify TI and its representatives against, any claims, damages, costs, losses, and liabilities arising out of your use of these resources.

TI's products are provided subject to TI's Terms of Sale (www.ti.com/legal/termsofsale.html) or other applicable terms available either on ti.com or provided in conjunction with such TI products. TI's provision of these resources does not expand or otherwise alter TI's applicable warranties or warranty disclaimers for TI products.

Mailing Address: Texas Instruments, Post Office Box 655303, Dallas, Texas 75265
Copyright © 2018, Texas Instruments Incorporated

Looking for pricing, stock, or lifecycle information?

Click below to explore more details on WIN SOURCE:

- ⊖ [View MSP430F5328TRGCTEP on WIN SOURCE](#)
- ⊖ [Texas Instruments Information](#)

Optimize Your Supply Chain with WIN SOURCE Solutions

- ✓ Global Sourcing Solution
- ✓ Obsolete Management
- ✓ Cost Control Management
- ✓ Shortage Management
- ✓ Alternative Solution
- ✓ Excess Inventory Management