



**THE DATASHEET OF
MSP430F2618TGQWTEP**



FEATURES

- Low Supply Voltage Range, 1.8 V to 3.6 V
- Ultra-Low Power Consumption:
 - Active Mode: 365 μ A at 1 MHz, 2.2 V
 - Standby Mode (VLO): 0.5 μ A
 - Off Mode (RAM Retention): 0.1 μ A
- Wake-Up From Standby Mode in Less Than 1 μ s
- 16-Bit RISC Architecture, 62.5-ns Instruction Cycle Time
- Three-Channel Internal DMA
- 12-Bit Analog-to-Digital (A/D) Converter With Internal Reference, Sample-and-Hold, and Autoscan Feature
- Dual 12-Bit Digital-to-Analog (D/A) Converters With Synchronization
- 16-Bit Timer_A With Three Capture/Compare Registers
- 16-Bit Timer_B With Seven Capture/Compare-With-Shadow Registers
- On-Chip Comparator
- Four Universal Serial Communication Interfaces (USCIs)
 - USCI_A0 and USCI_A1
 - Enhanced UART Supporting Auto-Baudrate Detection
 - IrDA Encoder and Decoder
 - Synchronous SPI
 - USCI_B0 and USCI_B1
 - I²C™
 - Synchronous SPI

- Supply Voltage Supervisor/Monitor With Programmable Level Detection
- Brownout Detector
- Bootstrap Loader
- Serial Onboard Programming, No External Programming Voltage Needed
- Programmable Code Protection by Security Fuse
- 116KB+256B Flash Memory, 8KB RAM
- Available in 113-Pin Ball Grid Array (BGA)
- For Complete Module Descriptions, See the *MSP430x2xx Family User's Guide*, Literature Number SLAU144

SUPPORTS DEFENSE, AEROSPACE, AND MEDICAL APPLICATIONS

- Controlled Baseline
- One Assembly/Test Site
- One Fabrication Site
- Extended Product Life Cycle
- Extended Product-Change Notification
- Product Traceability
- SnPb Solder Ball Alloy for Increased Reliability

description

The Texas Instruments MSP430 family of ultralow-power microcontrollers consists of several devices featuring different sets of peripherals targeted for various applications. The architecture, combined with five low-power modes is optimized to achieve extended battery life in portable measurement applications. The device features a powerful 16-bit RISC CPU, 16-bit registers, and constant generators that contribute to maximum code efficiency. The calibrated digitally controlled oscillator (DCO) allows wake-up from low-power modes to active mode in less than 1 μ s.



This integrated circuit can be damaged by ESD. Texas Instruments recommends that all integrated circuits be handled with appropriate precautions. Failure to observe proper handling and installation procedures can cause damage. ESD damage can range from subtle performance degradation to complete device failure. Precision integrated circuits may be more susceptible to damage because very small parametric changes could cause the device not to meet its published specifications. These devices have limited built-in ESD protection.



Please be aware that an important notice concerning availability, standard warranty, and use in critical applications of Texas Instruments semiconductor products and disclaimers thereto appears at the end of this data sheet.

I²C is a registered trademark of Philips Incorporated.

PRODUCTION DATA information is current as of publication date. Products conform to specifications per the terms of Texas Instruments standard warranty. Production processing does not necessarily include testing of all parameters.

Copyright © 2008, Texas Instruments Incorporated



MSP430F2618-EP MIXED SIGNAL MICROCONTROLLER

SLAS632 - DECEMBER 2008

description (continued)

The MSP430F2618 is a microcontroller configuration with two built-in 16-bit timers, a fast 12-bit A/D converter, a comparator, dual 12-bit D/A converters, four universal serial communication interface (USCI) modules, DMA, and up to 64 I/O pins. Typical applications include sensor systems, industrial control applications, hand-held meters, etc.

AVAILABLE OPTIONS

T _A	PACKAGED DEVICES
	PLASTIC 113-PIN BGA (GQW)
-40°C to 105°C	MSP430F2618TGQW

DEVELOPMENT TOOL SUPPORT

All MSP430 microcontrollers include an Embedded Emulation Module (EEM) allowing advanced debugging and programming through easy-to-use development tools. Recommended hardware options include:

- Debugging and Programming Interface
 - MSP-FET430UIF (USB)
 - MSP-FET430PIF (Parallel Port)
- Debugging and Programming Interface with Target Board
 - MSP-FET430U64
 - MSP-FET430U80
- Standalone Target Board
 - MSP-TS430PM64
- Production Programmer
 - MSP-GANG430



POST OFFICE BOX 655303 • DALLAS, TEXAS 75265

pin designation

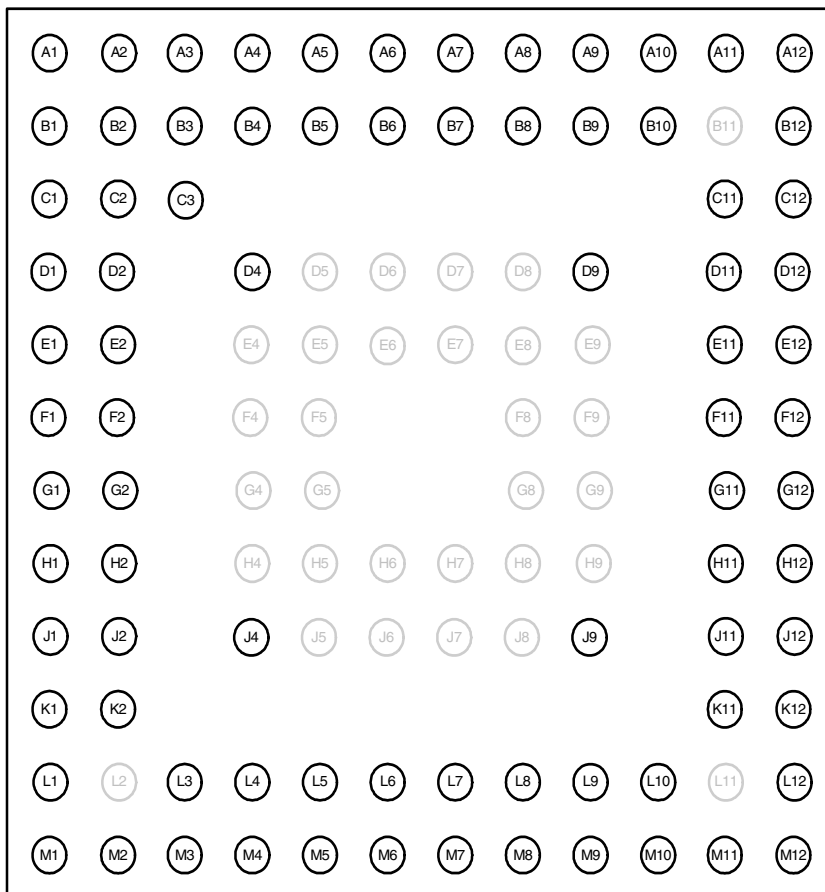

Note: For terminal assignments, see the *MSP430F261x Terminal Functions* table.

MSP430F2618-EP MIXED SIGNAL MICROCONTROLLER

SLAS632 - DECEMBER 2008

functional block diagram

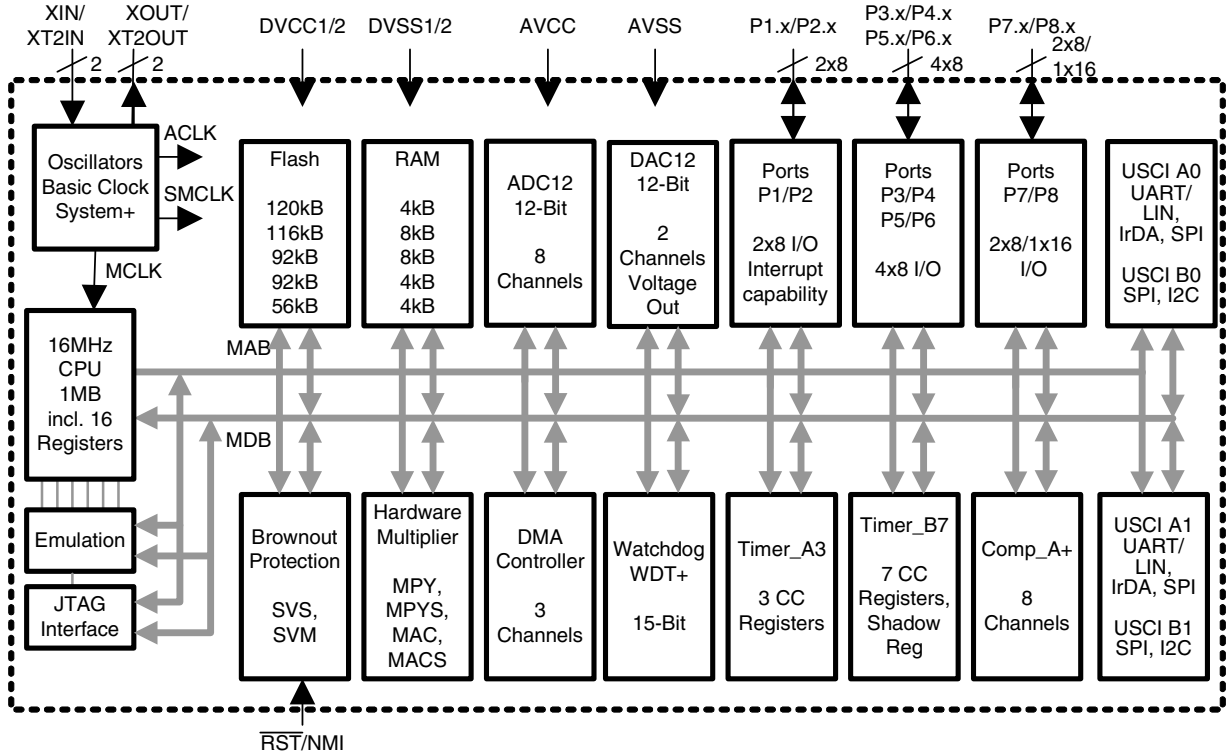

Terminal Functions

TERMINAL		I/O	DESCRIPTION
NAME	NO.		
AV _{CC}	A2		Analog supply voltage, positive terminal. Supplies only the analog portion of ADC12 and DAC12.
AV _{SS}	B2, B3		Analog supply voltage, negative terminal. Supplies only the analog portion of ADC12 and DAC12.
DV _{CC1}	A1		Digital supply voltage, positive terminal. Supplies all digital parts.
DV _{SS1}	A3		Digital supply voltage, negative terminal. Supplies all digital parts.
DV _{CC2}	F12		Digital supply voltage, positive terminal. Supplies all digital parts.
DV _{SS2}	E12		Digital supply voltage, negative terminal. Supplies all digital parts.
P1.0/TACLK/ CAOUT	G2	I/O	General-purpose digital I/O pin/Timer_A, clock signal TACLK input/Comparator_A output
P1.1/TA0	H1	I/O	General-purpose digital I/O pin/Timer_A, capture: CCI0A input, compare: Out0 output/BSL transmit
P1.2/TA1	H2	I/O	General-purpose digital I/O pin/Timer_A, capture: CCI1A input, compare: Out1 output
P1.3/TA2	J1	I/O	General-purpose digital I/O pin/Timer_A, capture: CCI2A input, compare: Out2 output
P1.4/SMCLK	J2	I/O	General-purpose digital I/O pin/SMCLK signal output
P1.5/TA0	K1	I/O	General-purpose digital I/O pin/Timer_A, compare: Out0 output
P1.6/TA1	K2	I/O	General-purpose digital I/O pin/Timer_A, compare: Out1 output
P1.7/TA2	L1	I/O	General-purpose digital I/O pin/Timer_A, compare: Out2 output
P2.0/ACLK/CA2	M1	I/O	General-purpose digital I/O pin/ACLK output/Comparator_A input
P2.1/TAINCLK/ CA3	M2	I/O	General-purpose digital I/O pin/Timer_A, clock signal at INCLK
P2.2/CAOUT/ TA0/CA4	M3	I/O	General-purpose digital I/O pin/Timer_A, capture: CCI0B input/Comparator_A output/BSL receive/Comparator_A input
P2.3/CA0/TA1	L3	I/O	General-purpose digital I/O pin/Timer_A, compare: Out1 output/Comparator_A input
P2.4/CA1/TA2	L4	I/O	General-purpose digital I/O pin/Timer_A, compare: Out2 output/Comparator_A input
P2.5/Rosc/CA5	M4	I/O	General-purpose digital I/O pin/input for external resistor defining the DCO nominal frequency/Comparator_A input
P2.6/ADC12CLK/ DMAE0/CA6	J4	I/O	General-purpose digital I/O pin/conversion clock – 12-bit ADC/DMA channel 0 external trigger/Comparator_A input
P2.7/TA0/CA7	L5	I/O	General-purpose digital I/O pin/Timer_A, compare: Out0 output/Comparator_A input
P3.0/UCB0STE/ UCA0CLK	M5	I/O	General-purpose digital I/O pin/USCI B0 slave transmit enable/USCI A0 clock input/output
P3.1/UCB0SIMO/ UCB0SDA	L6	I/O	General-purpose digital I/O pin/USCI B0 slave in/master out in SPI mode, SDA I ² C data in I ² C mode
P3.2/UCB0SOMI/ UCB0SCL	M6	I/O	General-purpose digital I/O pin/USCI B0 slave out/master in in SPI mode, SCL I ² C clock in I ² C mode
P3.3/UCB0CLK/ UCA0STE	L7	I/O	General-purpose digital I/O/USCI B0 clock input/output, USCI A0 slave transmit enable
P3.4/UCA0TXD/ UCA0SIMO	M7	I/O	General-purpose digital I/O pin/USCIA transmit data output in UART mode, slave data in/master out in SPI mode
P3.5/UCA0RXD/ UCA0SOMI	L8	I/O	General-purpose digital I/O pin/USCI A0 receive data input in UART mode, slave data out/master in in SPI mode

MSP430F2618-EP MIXED SIGNAL MICROCONTROLLER

SLAS632 - DECEMBER 2008

Terminal Functions (Continued)

TERMINAL		I/O	DESCRIPTION
NAME	NO.		
P3.6/UCA1TXD/ UCA1SIMO	M8	I/O	General-purpose digital I/O pin/USCI A1 transmit data output in UART mode, slave data in/master out in SPI mode
P3.7/UCA1RXD/ UCA1SOMI	L9	I/O	General-purpose digital I/O pin/USCIA1 receive data input in UART mode, slave data out/master in in SPI mode
P4.0/TB0	M9	I/O	General-purpose digital I/O pin/Timer_B, capture: CCI0A/B input, compare: Out0 output
P4.1/TB1	J9	I/O	General-purpose digital I/O pin/Timer_B, capture: CCI1A/B input, compare: Out1 output
P4.2/TB2	M10	I/O	General-purpose digital I/O pin/Timer_B, capture: CCI2A/B input, compare: Out2 output
P4.3/TB3	L10	I/O	General-purpose digital I/O pin/Timer_B, capture: CCI3A/B input, compare: Out3 output
P4.4/TB4	M11	I/O	General-purpose digital I/O pin/Timer_B, capture: CCI4A/B input, compare: Out4 output
P4.5/TB5	M12	I/O	General-purpose digital I/O pin/Timer_B, capture: CCI5A/B input, compare: Out5 output
P4.6/TB6	L12	I/O	General-purpose digital I/O pin/Timer_B, capture: CCI6A input, compare: Out6 output
P4.7/TBCLK	K11	I/O	General-purpose digital I/O pin/Timer_B, clock signal TBCLK input
P5.0/UCB1STE/ UCA1CLK	K12	I/O	General-purpose digital I/O pin/USCI B1 slave transmit enable/USCI A1 clock input/output
P5.1/UCB1SIMO/ UCB1SDA	J11	I/O	General-purpose digital I/O pin/USCI B1slave in/master out in SPI mode, SDA I ² C data in I ² C mode
P5.2/UCB1SOMI/ UCB1SCL	J12	I/O	General-purpose digital I/O pin/USCI B1slave out/master in in SPI mode, SCL I ² C clock in I ² C mode
P5.3/UCB1CLK/ UCA1STE	H11	I/O	General-purpose digital I/O/USCI B1 clock input/output, USCI A1 slave transmit enable
P5.4/MCLK	H12	I/O	General-purpose digital I/O pin/main system clock MCLK output
P5.5/SMCLK	G11	I/O	General-purpose digital I/O pin/submain system clock SMCLK output
P5.6/ACLK	G12	I/O	General-purpose digital I/O pin/auxiliary clock ACLK output
P5.7/TBOUTH/ SVSOUT	F11	I/O	General-purpose digital I/O pin/switch all PWM digital output ports to high impedance - Timer_B TB0 to TB6/SVS comparator output
P6.0/A0	D4	I/O	General-purpose digital I/O pin/analog input A0 – 12-bit ADC
P6.1/A1	A4	I/O	General-purpose digital I/O pin/analog input A1 – 12-bit ADC
P6.2/A2	B4	I/O	General-purpose digital I/O pin/analog input A2 – 12-bit ADC
P6.3/A3	B1	I/O	General-purpose digital I/O pin/analog input A3 – 12-bit ADC
P6.4/A4	C1	I/O	General-purpose digital I/O pin/analog input A4 – 12-bit ADC
P6.5/A5/DAC1	C2 C3	I/O	General-purpose digital I/O pin/analog input A5 – 12-bit ADC/DAC12.1 output
P6.6/A6/DAC0	D1	I/O	General-purpose digital I/O pin/analog input A6 – 12-bit ADC/DAC12.0 output
P6.7/A7/DAC1/ SVSIN	D2	I/O	General-purpose digital I/O pin/analog input a7 – 12-bit ADC/DAC12.1 output/SVS input
P7.0	E11	I/O	General-purpose digital I/O pin
P7.1	D12	I/O	General-purpose digital I/O pin
P7.2	D11	I/O	General-purpose digital I/O pin
P7.3	C12	I/O	General-purpose digital I/O pin
P7.4	C11	I/O	General-purpose digital I/O pin
P7.5	B12	I/O	General-purpose digital I/O pin
P7.6	A12	I/O	General-purpose digital I/O pin
P7.7	A11	I/O	General-purpose digital I/O pin



Terminal Functions (Continued)

TERMINAL		I/O	DESCRIPTION
NAME	NO.		
P8.0	B10	I/O	General-purpose digital I/O pin
P8.1	A10	I/O	General-purpose digital I/O pin
P8.2	D9	I/O	General-purpose digital I/O pin
P8.3	A9	I/O	General-purpose digital I/O pin
P8.4	B9	I/O	General-purpose digital I/O pin
P8.5	B8	I/O	General-purpose digital I/O pin
P8.6/XT2OUT	A8	O	General-purpose digital I/O pin/Output terminal of crystal oscillator XT2
P8.7/XT2IN	A7	I	General-purpose digital I/O pin/Input port for crystal oscillator XT2. Only standard crystals can be connected.
XT2OUT		O	Output terminal of crystal oscillator XT2
XT2IN		I	Input port for crystal oscillator XT2
RST/NMI	B5	I	Reset input, nonmaskable interrupt input port, or bootstrap loader start (in flash devices).
TCK	A5	I	Test clock (JTAG). TCK is the clock input port for device programming test and bootstrap loader start.
TDI/TCLK	A6	I	Test data input or test clock input. The device protection fuse is connected to TDI/TCLK.
TDO/TDI	B7	I/O	Test data output port. TDO/TDI data output or programming data input terminal.
TMS	B6	I	Test mode select. TMS is used as an input port for device programming and test.
V _{REF+} /DAC0	F2	I	Input for an external reference voltage/DAC12.0 output
V _{REF+}	E2	O	Output of positive terminal of the reference voltage in the ADC12
V _{REF-} /V _{REF-}	G1	I	Negative terminal for the reference voltage for both sources, the internal reference voltage, or an external applied reference voltage
XIN	E1	I	Input port for crystal oscillator XT1. Standard or watch crystals can be connected.
XOUT	F1	O	Output port for crystal oscillator XT1. Standard or watch crystals can be connected.
Reserved	L2, E4 F4, G4 H4, D5 E5, F5 G5, H5 J5, D6 E6, H6 J6, D7 E7, H7 J7, D8 E8, F8 G8, H8 J8, E9 F9, G9 H9, B11 L11	NA	Reserved pins. Connection to D/AV _{SS} recommended.

MSP430F2618-EP MIXED SIGNAL MICROCONTROLLER

SLAS632 - DECEMBER 2008

short-form description

CPU

The MSP430 CPU has a 16-bit RISC architecture that is highly transparent to the application. All operations, other than program-flow instructions, are performed as register operations in conjunction with seven addressing modes for source operand and four addressing modes for destination operand.

The CPU is integrated with 16 registers that provide reduced instruction execution time. The register-to-register operation execution time is one cycle of the CPU clock.

Four of the registers, R0 to R3, are dedicated as program counter, stack pointer, status register, and constant generator, respectively. The remaining registers are general-purpose registers.

Peripherals are connected to the CPU using data, address, and control buses, and can be handled with all instructions.

instruction set

The instruction set consists of 51 instructions with three formats and seven address modes. Each instruction can operate on word and byte data. Table 1 shows examples of the three types of instruction formats; the address modes are listed in Table 2.

Program Counter	PC/R0
Stack Pointer	SP/R1
Status Register	SR/CG1/R2
Constant Generator	CG2/R3
General-Purpose Register	R4
General-Purpose Register	R5
General-Purpose Register	R6
General-Purpose Register	R7
General-Purpose Register	R8
General-Purpose Register	R9
General-Purpose Register	R10
General-Purpose Register	R11
General-Purpose Register	R12
General-Purpose Register	R13
General-Purpose Register	R14
General-Purpose Register	R15

Table 1. Instruction Word Formats

Dual operands, source-destination	e.g., ADD R4,R5	R4 + R5 ---> R5
Single operands, destination only	e.g., CALL R8	PC -->(TOS), R8--> PC
Relative jump, un/conditional	e.g., JNE	Jump-on-equal bit = 0

Table 2. Address Mode Descriptions

ADDRESS MODE	S	D	SYNTAX	EXAMPLE	OPERATION
Register	●	●	MOV Rs,Rd	MOV R10,R11	R10 --> R11
Indexed	●	●	MOV X(Rn),Y(Rm)	MOV 2(R5),6(R6)	M(2+R5)--> M(6+R6)
Symbolic (PC relative)	●	●	MOV EDE,TONI		M(EDE) --> M(TONI)
Absolute	●	●	MOV &MEM,&TCDAT		M(MEM) --> M(TCDAT)
Indirect	●		MOV @Rn,Y(Rm)	MOV @R10,Tab(R6)	M(R10) --> M(Tab+R6)
Indirect autoincrement	●		MOV @Rn+,Rm	MOV @R10+,R11	M(R10) --> R11 R10 + 2--> R10
Immediate	●		MOV #X,TONI	MOV #45,TONI	#45 --> M(TONI)

NOTE: S = source D = destination



operating modes

The MSP430 has one active mode and five software-selectable low-power modes of operation. An interrupt event can wake up the device from any of the five low-power modes, service the request, and restore back to the low-power mode on return from the interrupt program.

The following six operating modes can be configured by software:

- Active mode (AM)
 - All clocks are active.
- Low-power mode 0 (LPM0)
 - CPU is disabled.
 - ACLK and SMCLK remain active. MCLK is disabled.
- Low-power mode 1 (LPM1)
 - CPU is disabled.
 - ACLK and SMCLK remain active. MCLK is disabled.
 - DCO's dc generator is disabled if DCO not used in active mode.
- Low-power mode 2 (LPM2)
 - CPU is disabled.
 - MCLK and SMCLK are disabled.
 - DCO's dc generator remains enabled.
 - ACLK remains active.
- Low-power mode 3 (LPM3)
 - CPU is disabled.
 - MCLK and SMCLK are disabled.
 - DCO's dc generator is disabled.
 - ACLK remains active.
- Low-power mode 4 (LPM4)
 - CPU is disabled.
 - ACLK is disabled.
 - MCLK and SMCLK are disabled.
 - DCO's dc generator is disabled.
 - Crystal oscillator is stopped.

MSP430F2618-EP MIXED SIGNAL MICROCONTROLLER

SLAS632 – DECEMBER 2008

interrupt vector addresses

The interrupt vectors and the power-up starting address are located in the address range 0x0FFFF to 0x0FFC0. The vector contains the 16-bit address of the appropriate interrupt-handler instruction sequence. If the reset vector (0x0FFFE) contains 0xFFFF (e.g., flash is not programmed), the CPU enters LPM4 after power-up.

INTERRUPT SOURCE	INTERRUPT FLAG	SYSTEM INTERRUPT	WORD ADDRESS	PRIORITY
Power-up External Reset Watchdog Flash Key Violation PC out of range (see Note 1)	PORIFG WDTIFG RSTIFG KEYV (see Note 2)	Reset	0x0FFFE	31, highest
NMI Oscillator Fault Flash memory access violation	NMIIFG OFIFG ACCVIFG (see Notes 2 and 6)	(Non)maskable (Non)maskable (Non)maskable	0x0FFFC	30
Timer_B7	TBCCR0 CCIFG (see Note 3)	Maskable	0x0FFFA	29
Timer_B7	TBCCR1 to TBCCR6 CCIFGs, TBIFG (see Notes 2 and 3)	Maskable	0x0FFF8	28
Comparator_A+	CAIFG	Maskable	0x0FFF6	27
Watchdog timer+	WDTIFG	Maskable	0x0FFF4	26
Timer_A3	TACCR0 CCIFG (see Note 3)	Maskable	0x0FFF2	25
Timer_A3	TACCR1 CCIFG TACCR2 CCIFG TAIFG (see Notes 2 and 3)	Maskable	0x0FFF0	24
USCI_A0/USCI_B0 receive USCI_B0 I2C status	UCA0RXIFG, UCB0RXIFG (see Notes 2 and 4)	Maskable	0x0FFEE	23
USCI_A0/USCI_B0 transmit USCI_B0 I2C receive/transmit	UCA0TXIFG, UCB0TXIFG (see Note 2 and 5)	Maskable	0x0FFEC	22
ADC12	ADC12IFG (see Notes 2 and 3)	Maskable	0x0FFEA	21
			0x0FFE8	20
I/O port P2 (eight flags)	P2IFG.0 to P2IFG.7 (see Notes 2 and 3)	Maskable	0x0FFE6	19
I/O port P1 (eight flags)	P1IFG.0 to P1IFG.7 (see Notes 2 and 3)	Maskable	0x0FFE4	18
USCI_A0/USCI_B1 receive USCI_B1 I2C status	UCA1RXIFG, UCB1RXIFG (see Notes 2 and 4)	Maskable	0x0FFE2	17
USCI_A1/USCI_B1 transmit USCI_B1 I2C receive/transmit	UCA1TXIFG, UCB1TXIFG (see Notes 2 and 5)	Maskable	0x0FFE0	16
DMA	DMA0IFG, DMA1IFG, DMA2IFG (see Notes 2 and 3)	Maskable	0x0FFDE	15
DAC12	DAC12_0IFG, DAC12_1IFG (see Notes 2 and 3)	Maskable	0x0FFDC	14
Reserved (see Notes 7 and 8)	Reserved		0x0FFDA to 0x0FFC0	13 to 0, lowest

- NOTES: 1. A reset is executed if the CPU tries to fetch instructions from within the module register memory address range (0x00000 to 0x001FF) or from within unused address ranges.
2. Multiple source flags.
3. Interrupt flags are located in the module.
4. In SPI mode: UCB0RXIFG. In I2C mode: UCALIFG, UCNACKIFG, ICSTTIFG, UCSTPIFG.
5. In UART/SPI mode: UCB0TXIFG. In I2C mode: UCB0RXIFG, UCB0TXIFG.
6. (Non)maskable: The individual interrupt-enable bit can disable an interrupt event, but the general-interrupt enable cannot.
7. The address 0x0FFBE is used as bootstrap loader security key (BSLSKEY).
A 0x0AA55 at this location disables the BSL completely.
A zero disables the erasure of the flash if an invalid password is supplied.
8. The interrupt vectors at addresses 0x0FFDA to 0x0FFC0 are not used in this device and can be used for regular program code if necessary.



special function registers

Most interrupt enable bits are collected in the lowest address space. Special-function register bits not allocated to a functional purpose are not physically present in the device. This arrangement provides simple software access.

interrupt enable 1 and 2

Address	7	6	5	4	3	2	1	0
00h			ACCVIE	NMIIE			OFIE	WDTIE
			rw-0	rw-0			rw-0	rw-0

Interrupt Enable Register 1

- WDTIE Watchdog timer interrupt enable. Inactive if watchdog mode is selected.
Active if watchdog timer is configured as general-purpose timer.
- OFIE Oscillator fault interrupt enable
- NMIIE Nonmaskable interrupt enable
- ACCVIE Flash memory access violation interrupt enable

Address	7	6	5	4	3	2	1	0
01h					UCB0TXIE	UCB0RXIE	UCA0TXIE	UCA0RXIE
					rw-0	rw-0	rw-0	rw-0

Interrupt Enable Register 2

- UCA0RXIE USCI_A0 receive interrupt enable
- UCA0TXIE USCI_A0 transmit interrupt enable
- UCB0RXIE USCI_B0 receive interrupt enable
- UCB0TXIE USCI_B0 transmit interrupt enable

MSP430F2618-EP MIXED SIGNAL MICROCONTROLLER

SLAS632 - DECEMBER 2008

interrupt flag register 1 and 2

Address	7	6	5	4	3	2	1	0
02h				NMIIFG	RSTIFG	PORIFG	OFIFG	WDTIFG
				rw-0	rw-(0)	rw-(1)	rw-1	rw-(0)

Interrupt Flag Register 1

- WDTIFG Set on watchdog timer overflow or security key violation
Reset on V_{CC} power-on or a reset condition at the \overline{RST}/NMI pin in reset mode.
- OFIFG Flag set on oscillator fault7
- PORIFG Power-on interrupt flag. Set on V_{CC} power up.
- RSTIFG External reset interrupt flag. Set on a reset condition at \overline{RST}/NMI pin in reset mode. Reset on V_{CC} power up.
- NMIIFG Set via \overline{RST}/NMI pin

Address	7	6	5	4	3	2	1	0
03h					UCB0TX IFG	UCB0RX IFG	UCA0TX IFG	UCA0RX IFG
					rw-1	rw-0	rw-1	rw-0

Interrupt Flag Register 2

- UCA0RXIFG USCI_A0 receive interrupt flag
- UCA0TXIFG USCI_A0 transmit interrupt flag
- UCB0RXIFG USCI_B0 receive interrupt flag
- UCB0TXIFG USCI_B0 transmit interrupt flag

Legend

- rw: Bit can be read and written.
- rw-0,1: Bit can be read and written. It is Reset or Set by PUC.
- rw-(0,1) Bit can be read and written. It is Reset or Set by POR.
SFR bit is not present in device.

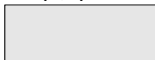

memory organization

Memory Main: interrupt vector Main: code memory	Size Flash Flash	116KB 0x0FFFF - 0x0FFC0 0x1FFFF - 0x03100
RAM (total)	Size	8kB 0x030FF - 0x01100
Extended	Size	6kB 0x030FF - 0x01900
Mirrored	Size	2kB 0x018FF - 0x01100
Information memory	Size Flash	256 Byte 0x010FF - 0x01000
Boot memory	Size ROM	1KB 0x00FFF - 0x00C00
RAM (mirrored at 0x18FF to 0x01100)	Size	2KB 0x009FF - 0x00200
Peripherals	16-bit 8-bit 8-bit SFR	0x001FF - 0x00100 0x000FF - 0x00010 0x0000F - 0x00000

bootstrap loader (BSL)

The MSP430 BSL enables users to program the flash memory or RAM using a UART serial interface. Access to the MSP430 memory via the BSL is protected by a user-defined password. For complete description of the features of the BSL and its implementation, see the application report *Features of the MSP430 Bootstrap Loader*, literature number SLAA089.

BSL Function	Pins
Data Transmit	H1 - P1.1
Data Receive	M3 - P2.2

flash memory

The flash memory can be programmed via the JTAG port, the bootstrap loader, or in-system by the CPU. The CPU can perform single-byte and single-word writes to the flash memory. Features of the flash memory include:

- Flash memory has n segments of main memory and four segments of information memory (A to D) of 64 bytes each. Each segment in main memory is 512 bytes in size.
- Segments 0 to n may be erased in one step, or each segment may be individually erased.
- Segments A to D can be erased individually, or as a group with segments 0 to n. Segments A to D are also called *information memory*.
- Segment A contains calibration data. After reset, segment A is protected against programming or erasing. It can be unlocked, but care should be taken not to erase this segment if the calibration data is required.
- Flash content integrity check with marginal read modes

peripherals

Peripherals are connected to the CPU through data, address, and control buses and can be handled using all instructions. For complete module descriptions, see the *MSP430x2xx Family User's Guide*, literature number SLAU144.

MSP430F2618-EP

MIXED SIGNAL MICROCONTROLLER

SLAS632 - DECEMBER 2008

DMA controller

The DMA controller allows movement of data from one memory address to another without CPU intervention. For example, the DMA controller can be used to move data from the ADC12 conversion memory to RAM. Using the DMA controller can increase the throughput of peripheral modules. The DMA controller reduces system power consumption by allowing the CPU to remain in sleep mode without having to awaken to move data to or from a peripheral.

oscillator and system clock

The clock system in the MSP43x261x family of devices is supported by the basic clock module that includes support for a 32768-Hz watch crystal oscillator, an internal very low-power low-frequency oscillator, an internal digitally controlled oscillator (DCO), and a high-frequency crystal oscillator. The basic clock module is designed to meet the requirements of both low system cost and low power consumption. The internal DCO provides a fast turn-on clock source and stabilizes in less than 1 μ s. The basic clock module provides the following clock signals:

- Auxiliary clock (ACLK), sourced from a 32768-Hz watch crystal, a high-frequency crystal, or a very low-power LF oscillator
- Main clock (MCLK), the system clock used by the CPU
- Sub-Main clock (SMCLK), the subsystem clock used by the peripheral modules

The DCO settings to calibrate the DCO output frequency are stored in the information memory segment A.



calibration data stored in information memory segment A

Calibration data is stored for the DCO and for the ADC12. It is organized in a tag-length-value (TLV) structure.

TAGS USED BY THE ADC CALIBRATION TAGS			
NAME	ADDRESS	VALUE	DESCRIPTION
TAG_DCO_30	0x10F6	0x01	DCO frequency calibration at $V_{CC} = 3\text{ V}$ and $T_A = 25^\circ\text{C}$ at calibration
TAG_ADC12_1	0x10DA	0x10	ADC12_1 calibration tag
TAG_EMPTY	-	0xFE	Identifier for empty memory areas

LABELS USED BY THE ADC CALIBRATION TAGS			
LABEL	CONDITION AT CALIBRATION / DESCRIPTION	SIZE	ADDRESS OFFSET
CAL_ADC_25T85	INCHx = 0x1010; REF2_5 = 1, $T_A = 85^\circ\text{C}$	word	0x000E
CAL_ADC_25T30	INCHx = 0x1010; REF2_5 = 1, $T_A = 30^\circ\text{C}$	word	0x000C
CAL_ADC_25VREF_FACTOR	REF2_5 = 1, $T_A = 30^\circ\text{C}$	word	0x000A
CAL_ADC_15T85	INCHx = 0x1010; REF2_5 = 0, $T_A = 85^\circ\text{C}$	word	0x0008
CAL_ADC_15T30	INCHx = 0x1010; REF2_5 = 0, $T_A = 30^\circ\text{C}$	word	0x0006
CAL_ADC_15VREF_FACTOR	REF2_5 = 0, $T_A = 30^\circ\text{C}$	word	0x0004
CAL_ADC_OFFSET	External $V_{REF} = 1.5\text{ V}$, $f_{ADC12CLK} = 5\text{ MHz}$	word	0x0002
CAL_ADC_GAIN_FACTOR	External $V_{REF} = 1.5\text{ V}$, $f_{ADC12CLK} = 5\text{ MHz}$	word	0x0000
CAL_BC1_1MHZ	-	byte	0x0007
CAL_DCO_1MHZ	-	byte	0x0006
CAL_BC1_8MHZ	-	byte	0x0005
CAL_DCO_8MHZ	-	byte	0x0004
CAL_BC1_12MHZ	-	byte	0x0003
CAL_DCO_12MHZ	-	byte	0x0002
CAL_BC1_16MHZ	-	byte	0x0001
CAL_DCO_16MHZ	-	byte	0x0000

brownout, supply voltage supervisor (SVS)

The brownout circuit is implemented to provide the proper internal reset signal to the device during power on and power off. The SVS circuitry detects if the supply voltage drops below a user selectable level and supports both supply voltage supervision (the device is automatically reset) and supply voltage monitoring (SVM) (the device is not automatically reset).

The CPU begins code execution after the brownout circuit releases the device reset. However, V_{CC} may not have ramped to $V_{CC(\text{min})}$ at that time. The user must ensure that the default DCO settings are not changed until V_{CC} reaches $V_{CC(\text{min})}$. If desired, the SVS circuit can be used to determine when V_{CC} reaches $V_{CC(\text{min})}$.

digital I/O

There are up to eight 8-bit I/O ports implemented—ports P1 through P8:

- All individual I/O bits are independently programmable.
- Any combination of input, output, and interrupt conditions is possible.
- Edge-selectable interrupt input capability for all eight bits of ports P1 and P2.
- Read/write access to port-control registers is supported by all instructions.
- Each I/O has an individually programmable pullup/pulldown resistor.
- Ports P7/P8 can be accessed word-wise.

MSP430F2618-EP

MIXED SIGNAL MICROCONTROLLER

SLAS632 - DECEMBER 2008

watchdog timer+ (WDT+)

The primary function of the WDT+ module is to perform a controlled system restart after a software problem occurs. If the selected time interval expires, a system reset is generated. If the watchdog function is not needed in an application, the module can be configured as an interval timer and can generate interrupts at selected time intervals.

hardware multiplier

The multiplication operation is supported by a dedicated peripheral module. The module performs 16×16 , 16×8 , 8×16 , and 8×8 bit operations. The module is capable of supporting signed and unsigned multiplication as well as signed and unsigned multiply and accumulate operations. The result of an operation can be accessed immediately after the operands have been loaded into the peripheral registers. No additional clock cycles are required.

universal serial communication interface (USCI)

The USCI modules are used for serial data communication. The USCI module supports synchronous communication protocols such as SPI (3 pin or 4 pin) or I²C, and asynchronous combination protocols such as UART, enhanced UART with automatic baudrate detection (LIN), and IrDA.

The USCI A module provides support for SPI (3 pin or 4 pin), UART, enhanced UART, and IrDA.

The USCI B module provides support for SPI (3 pin or 4 pin) and I²C.



timer_A3

Timer_A3 is a 16-bit timer/counter with three capture/compare registers. Timer_A3 can support multiple capture/compares, PWM outputs, and interval timing. Timer_A3 also has extensive interrupt capabilities. Interrupts may be generated from the counter on overflow conditions and from each of the capture/compare registers.

TIMER_A3 SIGNAL CONNECTIONS					
INPUT PIN NUMBER	DEVICE INPUT SIGNAL	MODULE INPUT NAME	MODULE BLOCK	MODULE OUTPUT SIGNAL	OUTPUT PIN NUMBER
G2 - P1.0	TACLK	TACLK	Timer	NA	
	ACLK	ACLK			
	SMCLK	SMCLK			
M2 - P2.1	TAINCLK	INCLK			
H1 - P1.1	TA0	CCI0A	CCR0	TA0	H1 - P1.1
M3 - P2.2	TA0	CCI0B			K1 - P1.5
	DV _{SS}	GND			L5 - P2.7
	DV _{CC}	V _{CC}			
H2 - P1.2	TA1	CCI1A	CCR1	TA1	H2 - P1.2
	CAOUT (internal)	CCI1B			K2 - P1.6
	DV _{SS}	GND			L3 - P2.3
	DV _{CC}	V _{CC}			ADC12 (internal)
					DAC12_0 (internal)
			DAC12_1 (internal)		
J1 - P1.3	TA2	CCI2A	CCR2	TA2	J1 - P1.3
	ACLK (internal)	CCI2B			L1 - P1.7
	DV _{SS}	GND			L4 - P2.4
	DV _{CC}	V _{CC}			

MSP430F2618-EP MIXED SIGNAL MICROCONTROLLER

SLAS632 - DECEMBER 2008

timer_B7

Timer_B7 is a 16-bit timer/counter with seven capture/compare registers. Timer_B7 can support multiple capture/comparisons, PWM outputs, and interval timing. Timer_B7 also has extensive interrupt capabilities. Interrupts may be generated from the counter on overflow conditions and from each of the capture/compare registers.

TIMER_B3/B7 SIGNAL CONNECTIONS [†]					
INPUT PIN NUMBER	DEVICE INPUT SIGNAL	MODULE INPUT NAME	MODULE BLOCK	MODULE OUTPUT SIGNAL	OUTPUT PIN NUMBER
K11 - P4.7	TBCLK	TBCLK	Timer	NA	
	ACLK	ACLK			
	SMCLK	SMCLK			
K11 - P4.7	TBCLK	INCLK			
M9 - P4.0	TB0	CCI0A	CCR0	TB0	M9 - P4.0
M9 - P4.0	TB0	CCI0B			ADC12 (internal)
	DV _{SS}	GND			
	DV _{CC}	V _{CC}			
J9 - P4.1	TB1	CCI1A	CCR1	TB1	J9 - P4.1
J9 - P4.1	TB1	CCI1B			ADC12 (internal)
	DV _{SS}	GND			
	DV _{CC}	V _{CC}			
M10 - P4.2	TB2	CCI2A	CCR2	TB2	M10 - P4.2
M10 - P4.2	TB2	CCI2B			DAC_0(internal)
	DV _{SS}	GND			DAC_1(internal)
	DV _{CC}	V _{CC}			
L10 - P4.3	TB3	CCI3A	CCR3	TB3	L10 - P4.3
L10 - P4.3	TB3	CCI3B			
	DV _{SS}	GND			
	DV _{CC}	V _{CC}			
M11 - P4.4	TB4	CCI4A	CCR4	TB4	M11 - P4.4
M11 - P4.4	TB4	CCI4B			
	DV _{SS}	GND			
	DV _{CC}	V _{CC}			
M12 - P4.5	TB5	CCI5A	CCR5	TB5	M12 - P4.5
M12 - P4.5	TB5	CCI5B			
	DV _{SS}	GND			
	DV _{CC}	V _{CC}			
L12 - P4.6	TB6	CCI6A	CCR6	TB6	L12 - P4.6
	ACLK (internal)	CCI6B			
	DV _{SS}	GND			
	DV _{CC}	V _{CC}			



comparator_A+

The primary function of the comparator_A+ module is to support precision slope analog-to-digital conversions, battery-voltage supervision, and monitoring of external analog signals.

ADC12

The ADC12 module supports fast 12-bit analog-to-digital conversions. The module implements a 12-bit SAR core, sample select control, reference generator, and a 16-word conversion-and-control buffer. The conversion-and-control buffer allows up to 16 independent ADC samples to be converted and stored without any CPU intervention.

DAC12

The DAC12 module is a 12-bit, R-ladder, voltage-output digital-to-analog converter (DAC). The DAC12 may be used in 8-bit or 12-bit mode and may be used in conjunction with the DMA controller. When multiple DAC12 modules are present, they may be grouped together for synchronous operation.

MSP430F2618-EP MIXED SIGNAL MICROCONTROLLER

SLAS632 - DECEMBER 2008

peripheral file map

PERIPHERAL FILE MAP			
DMA†	DMA channel 2 transfer size	DMA2SZ	0x01F2
	DMA channel 2 destination address	DMA2DA	0x01EE
	DMA channel 2 source address	DMA2SA	0x01EA
	DMA channel 2 control	DMA2CTL	0x01E8
	DMA channel 1 transfer size	DMA1SZ	0x01E6
	DMA channel 1 destination address	DMA1DA	0x01E2
	DMA channel 1 source address	DMA1SA	0x01DE
	DMA channel 1 control	DMA1CTL	0x01DC
	DMA channel 0 transfer size	DMA0SZ	0x01DA
	DMA channel 0 destination address	DMA0DA	0x01D6
	DMA channel 0 source address	DMA0SA	0x01D2
	DMA channel 0 control	DMA0CTL	0x01D0
	DMA module interrupt vector word	DMAIV	0x0126
	DMA module control 1	DMACTL1	0x0124
DMA module control 0	DMACTL0	0x0122	
DAC12†	DAC12_1 data	DAC12_1DAT	0x01CA
	DAC12_1 control	DAC12_1CTL	0x01C2
	DAC12_0 data	DAC12_0DAT	0x01C8
	DAC12_0 control	DAC12_0CTL	0x01C0
ADC12	Interrupt-vector-word register	ADC12IV	0x01A8
	Interrupt-enable register	ADC12IE	0x01A6
	Interrupt-flag register	ADC12IFG	0x01A4
	Control register 1	ADC12CTL1	0x01A2
	Control register 0	ADC12CTL0	0x01A0
	Conversion memory 15	ADC12MEM15	0x015E
	Conversion memory 14	ADC12MEM14	0x015C
	Conversion memory 13	ADC12MEM13	0x015A
	Conversion memory 12	ADC12MEM12	0x0158
	Conversion memory 11	ADC12MEM11	0x0156
	Conversion memory 10	ADC12MEM10	0x0154
	Conversion memory 9	ADC12MEM9	0x0152
	Conversion memory 8	ADC12MEM8	0x0150
	Conversion memory 7	ADC12MEM7	0x014E
	Conversion memory 6	ADC12MEM6	0x014C
	Conversion memory 5	ADC12MEM5	0x014A
	Conversion memory 4	ADC12MEM4	0x0148
	Conversion memory 3	ADC12MEM3	0x0146
	Conversion memory 2	ADC12MEM2	0x0144
	Conversion memory 1	ADC12MEM1	0x0142
Conversion memory 0	ADC12MEM0	0x0140	

† MSP430F261x devices only



PERIPHERAL FILE MAP (CONTINUED)			
ADC12 (continued)	ADC memory-control register15	ADC12MCTL15	0x008F
	ADC memory-control register14	ADC12MCTL14	0x008E
	ADC memory-control register13	ADC12MCTL13	0x008D
	ADC memory-control register12	ADC12MCTL12	0x008C
	ADC memory-control register11	ADC12MCTL11	0x008B
	ADC memory-control register10	ADC12MCTL10	0x008A
	ADC memory-control register9	ADC12MCTL9	0x0089
	ADC memory-control register8	ADC12MCTL8	0x0088
	ADC memory-control register7	ADC12MCTL7	0x0087
	ADC memory-control register6	ADC12MCTL6	0x0086
	ADC memory-control register5	ADC12MCTL5	0x0085
	ADC memory-control register4	ADC12MCTL4	0x0084
	ADC memory-control register3	ADC12MCTL3	0x0083
	ADC memory-control register2	ADC12MCTL2	0x0082
	ADC memory-control register1	ADC12MCTL1	0x0081
	ADC memory-control register0	ADC12MCTL0	0x0080
Timer_B7	Capture/compare register 6	TBCCR6	0x019E
	Capture/compare register 5	TBCCR5	0x019C
	Capture/compare register 4	TBCCR4	0x019A
	Capture/compare register 3	TBCCR3	0x0198
	Capture/compare register 2	TBCCR2	0x0196
	Capture/compare register 1	TBCCR1	0x0194
	Capture/compare register 0	TBCCR0	0x0192
	Timer_B register	TBR	0x0190
	Capture/compare control 6	TBCCTL6	0x018E
	Capture/compare control 5	TBCCTL5	0x018C
	Capture/compare control 4	TBCCTL4	0x018A
	Capture/compare control 3	TBCCTL3	0x0188
	Capture/compare control 2	TBCCTL2	0x0186
	Capture/compare control 1	TBCCTL1	0x0184
	Capture/compare control 0	TBCCTL0	0x0182
	Timer_B control	TBCTL	0x0180
	Timer_B interrupt vector	TBIV	0x011E
	Timer_A3	Capture/compare register 2	TACCR2
Capture/compare register 1		TACCR1	0x0174
Capture/compare register 0		TACCR0	0x0172
Timer_A register		TAR	0x0170
Reserved			0x016E
Reserved			0x016C
Reserved			0x016A
Reserved			0x0168
Capture/compare control 2		TACCTL2	0x0166
Capture/compare control 1		TACCTL1	0x0164
Capture/compare control 0		TACCTL0	0x0162
Timer_A control		TACTL	0x0160
Timer_A interrupt vector		TAIV	0x012E

MSP430F2618-EP MIXED SIGNAL MICROCONTROLLER

SLAS632 - DECEMBER 2008

PERIPHERAL FILE MAP (CONTINUED)			
Hardware Multiplier	Sum extend	SUMEXT	0x013E
	Result high word	RESHI	0x013C
	Result low word	RESLO	0x013A
	Second operand	OP2	0x0138
	Multiply signed +accumulate/operand1	MACS	0x0136
	Multiply+accumulate/operand1	MAC	0x0134
	Multiply signed/operand1	MPYS	0x0132
	Multiply unsigned/operand1	MPY	0x0130
Flash	Flash control 4	FCTL4	0x01BE
	Flash control 3	FCTL3	0x012C
	Flash control 2	FCTL2	0x012A
	Flash control 1	FCTL1	0x0128
Watchdog	Watchdog Timer control	WDTCTL	0x0120
USCI A0/B0	USCI A0 auto baud rate control	UCA0ABCTL	0x005D
	USCI A0 transmit buffer	UCA0TXBUF	0x0067
	USCI A0 receive buffer	UCA0RXBUF	0x0066
	USCI A0 status	UCA0STAT	0x0065
	USCI A0 modulation control	UCA0MCTL	0x0064
	USCI A0 baud rate control 1	UCA0BR1	0x0063
	USCI A0 baud rate control 0	UCA0BR0	0x0062
	USCI A0 control 1	UCA0CTL1	0x0061
	USCI A0 control 0	UCA0CTL0	0x0060
	USCI A0 IrDA receive control	UCA0IRRCTL	0x005F
	USCI A0 IrDA transmit control	UCA0IRTCLT	0x005E
	USCI B0 transmit buffer	UCB0TXBUF	0x006F
	USCI B0 receive buffer	UCB0RXBUF	0x006E
	USCI B0 status	UCB0STAT	0x006D
	USCI B0 I2C Interrupt enable	UCB0CIE	0x006C
	USCI B0 baud rate control 1	UCB0BR1	0x006B
	USCI B0 baud rate control 0	UCB0BR0	0x006A
	USCI B0 control 1	UCB0CTL1	0x0069
	USCI B0 control 0	UCB0CTL0	0x0068
	USCI B0 I2C slave address	UCB0SA	0x011A
USCI B0 I2C own address	UCB0OA	0x0118	
USCI A1/B1	USCI A1 auto baud rate control	UCA1ABCTL	0x00CD
	USCI A1 transmit buffer	UCA1TXBUF	0x00D7
	USCI A1 receive buffer	UCA1RXBUF	0x00D6
	USCI A1 status	UCA1STAT	0x00D5
	USCI A1 modulation control	UCA1MCTL	0x00D4
	USCI A1 baud rate control 1	UCA1BR1	0x00D3
	USCI A1 baud rate control 0	UCA1BR0	0x00D2
	USCI A1 control 1	UCA1CTL1	0x00D1
	USCI A1 control 0	UCA1CTL0	0x00D0
	USCI A1 IrDA receive control	UCA1IRRCTL	0x00CF
	USCI A1 IrDA transmit control	UCA1IRTCLT	0x00CE



PERIPHERAL FILE MAP (CONTINUED)			
USCI A1/B1 (continued)	USCI B1 transmit buffer	UCB1TXBUF	0x00DF
	USCI B1 receive buffer	UCB1RXBUF	0x00DE
	USCI B1 status	UCB1STAT	0x00DD
	USCI B1 I2C Interrupt enable	UCB1CIE	0x00DC
	USCI B1 baud rate control 1	UCB1BR1	0x00DB
	USCI B1 baud rate control 0	UCB1BR0	0x00DA
	USCI B1 control 1	UCB1CTL1	0x00D9
	USCI B1 control 0	UCB1CTL0	0x00D8
	USCI B1 I2C slave address	UCB1SA	0x017E
	USCI B1 I2C own address	UCB1OA	0x017C
	USCI A1/B1 interrupt enable	UC1IE	0x0006
	USCI A1/B1 interrupt flag	UC1IFG	0x0007
Comparator_A+	Comparator_A port disable	CAPD	0x005B
	Comparator_A control2	CACTL2	0x005A
	Comparator_A control1	CACTL1	0x0059
Basic Clock	Basic clock system control3	BCSCTL3	0x0053
	Basic clock system control2	BCSCTL2	0x0058
	Basic clock system control1	BCSCTL1	0x0057
	DCO clock frequency control	DCOCTL	0x0056
Brownout, SVS	SVS control register (reset by brownout signal)	SVSCTL	0x0055
Port PA	Port PA resistor enable	PAREN	0x0014
	Port PA selection	PASEL	0x003E
	Port PA direction	PADIR	0x003C
	Port PA output	PAOUT	0x003A
	Port PA input	PAIN	0x0038
Port P8	Port P8 resistor enable	P8REN	0x0015
	Port P8 selection	P8SEL	0x003F
	Port P8 direction	P8DIR	0x003D
	Port P8 output	P8OUT	0x003B
	Port P8 input	P8IN	0x0039
Port P7	Port P7 resistor enable	P7REN	0x0014
	Port P7 selection	P7SEL	0x003E
	Port P7 direction	P7DIR	0x003C
	Port P7 output	P7OUT	0x003A
	Port P7 input	P7IN	0x0038
Port P6	Port P6 resistor enable	P6REN	0x0013
	Port P6 selection	P6SEL	0x0037
	Port P6 direction	P6DIR	0x0036
	Port P6 output	P6OUT	0x0035
	Port P6 input	P6IN	0x0034
Port P5	Port P5 resistor enable	P5REN	0x0012
	Port P5 selection	P5SEL	0x0033
	Port P5 direction	P5DIR	0x0032
	Port P5 output	P5OUT	0x0031
	Port P5 input	P5IN	0x0030

MSP430F2618-EP MIXED SIGNAL MICROCONTROLLER

SLAS632 - DECEMBER 2008

PERIPHERAL FILE MAP (CONTINUED)			
Port P4	Port P4 selection	P4SEL	0x001F
	Port P4 resistor enable	P4REN	0x0011
	Port P4 direction	P4DIR	0x001E
	Port P4 output	P4OUT	0x001D
	Port P4 input	P4IN	0x001C
Port P3	Port P3 resistor enable	P3REN	0x0010
	Port P3 selection	P3SEL	0x001B
	Port P3 direction	P3DIR	0x001A
	Port P3 output	P3OUT	0x0019
	Port P3 input	P3IN	0x0018
Port P2	Port P2 resistor enable	P2REN	0x002F
	Port P2 selection	P2SEL	0x002E
	Port P2 interrupt enable	P2IE	0x002D
	Port P2 interrupt-edge select	P2IES	0x002C
	Port P2 interrupt flag	P2IFG	0x002B
	Port P2 direction	P2DIR	0x002A
	Port P2 output	P2OUT	0x0029
	Port P2 input	P2IN	0x0028
Port P1	Port P1 resistor enable	P1REN	0x0027
	Port P1 selection	P1SEL	0x0026
	Port P1 interrupt enable	P1IE	0x0025
	Port P1 interrupt-edge select	P1IES	0x0024
	Port P1 interrupt flag	P1IFG	0x0023
	Port P1 direction	P1DIR	0x0022
	Port P1 output	P1OUT	0x0021
	Port P1 input	P1IN	0x0020
Special Functions	SFR interrupt flag2	IFG2	0x0003
	SFR interrupt flag1	IFG1	0x0002
	SFR interrupt enable2	IE2	0x0001
	SFR interrupt enable1	IE1	0x0000



MSP430F2618-EP MIXED SIGNAL MICROCONTROLLER

SLAS632 - DECEMBER 2008

electrical characteristics over recommended ranges of supply voltage and operating free-air temperature (unless otherwise noted)

active mode supply current into V_{CC} excluding external current (see Notes 1 and 2)

PARAMETER	TEST CONDITIONS	T_A	V_{CC}	MIN	TYP	MAX	UNIT
$I_{AM, 1MHz}$ Active mode (AM) current (1 MHz)	$f_{DCO} = f_{MCLK} = f_{SMCLK} = 1 \text{ MHz}$, $f_{ACLK} = 32,768 \text{ Hz}$, Program executes from flash, $BCSCTL1 = CALBC1_1MHz$, $DCOCTL = CALDCO_1MHz$, $CPUOFF = 0$, $SCG0 = 0$, $SCG1 = 0$, $OSCOFF = 0$	-40°C to 85°C	2.2 V	365		395	μA
		105°C		375		420	
		-40°C to 85°C	3 V	515		560	
		105°C		525		595	
$I_{AM, 1MHz}$ Active mode (AM) current (1 MHz)	$f_{DCO} = f_{MCLK} = f_{SMCLK} = 1 \text{ MHz}$, $f_{ACLK} = 32,768 \text{ Hz}$, Program executes in RAM, $BCSCTL1 = CALBC1_1MHz$, $DCOCTL = CALDCO_1MHz$, $CPUOFF = 0$, $SCG0 = 0$, $SCG1 = 0$, $OSCOFF = 0$	-40°C to 85°C	2.2 V	330		370	μA
		105°C		340		390	
		-40°C to 85°C	3 V	460		495	
		105°C		470		520	
$I_{AM, 4kHz}$ Active mode (AM) current (4 kHz)	$f_{MCLK} = f_{SMCLK} =$ $f_{ACLK} = 32,768 \text{ Hz}/8 = 4,096 \text{ Hz}$, $f_{DCO} = 0 \text{ Hz}$, Program executes in flash, $SELMx = 11$, $SELS = 1$, $DIVMx = DIVSx = DIVAx = 11$, $CPUOFF = 0$, $SCG0 = 1$, $SCG1 = 0$, $OSCOFF = 0$	-40°C to 85°C	2.2 V	2.1		9	μA
		105°C		15		31	
		-40°C to 85°C	3 V	3		11	
		105°C		19		32	
$I_{AM, 100kHz}$ Active mode (AM) current (100 kHz)	$f_{MCLK} = f_{SMCLK} = f_{DCO(0,0)} \approx 100 \text{ kHz}$, $f_{ACLK} = 0 \text{ Hz}$, Program executes in flash, $RSELx = 0$, $DCOx = 0$, $CPUOFF = 0$, $SCG0 = 0$, $SCG1 = 0$, $OSCOFF = 1$	-40°C to 85°C	2.2 V	67		86	μA
		105°C		80		99	
		-40°C to 85°C	3 V	84		107	
		105°C		99		128	

- NOTES: 1. All inputs are tied to 0 V or V_{CC} . Outputs do not source or sink any current.
2. The currents are characterized with a micro crystal CC4V-T1A SMD crystal with a load capacitance of 9 pF. The internal and external load capacitance is chosen to closely match the required 9 pF.

electrical characteristics over recommended ranges of supply voltage and operating free-air temperature (unless otherwise noted)

typical characteristics - active mode supply current (into $DV_{CC} + AV_{CC}$)

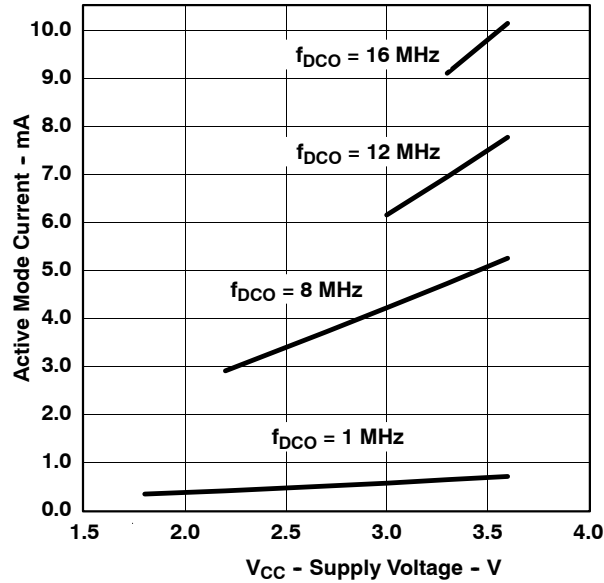

Figure 2. Active Mode Current vs V_{CC} , $T_A = 25^\circ\text{C}$

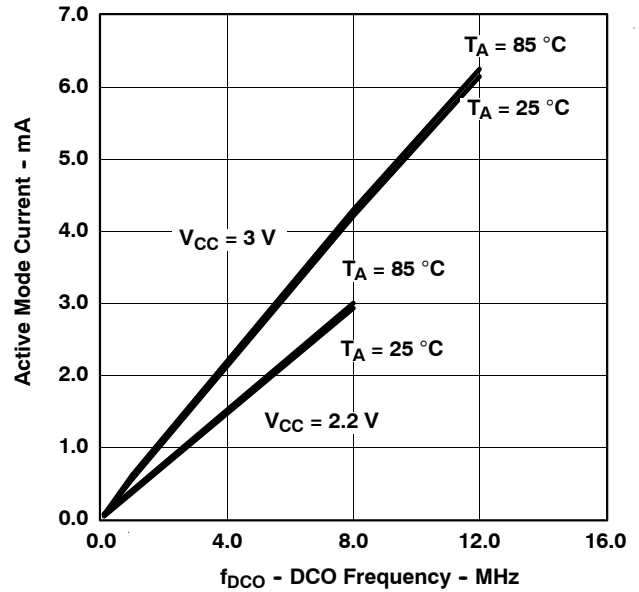

Figure 3. Active Mode Current vs DCO Frequency

MSP430F2618-EP MIXED SIGNAL MICROCONTROLLER

SLAS632 - DECEMBER 2008

electrical characteristics over recommended ranges of supply voltage and operating free-air temperature (unless otherwise noted)

low-power mode supply current into V_{CC} excluding external current (see Notes 1 and 2)

PARAMETER	TEST CONDITIONS	T_A	V_{CC}	MIN	TYP	MAX	UNIT
$I_{LPM0, 1MHz}$ Low-power mode 0 (LPM0) current, see Note 3	$f_{MCLK} = 0$ MHz, $f_{SMCLK} = f_{DCO} = 1$ MHz, $f_{ACLK} = 32,768$ Hz, BCSCTL1 = CALBC1_1MHZ, DCOCTL = CALDCO_1MHZ, CPUOFF = 1, SCG0 = 0, SCG1 = 0, OSCOFF = 0	-40°C to 85°C	2.2 V	68	83	μ A	
		105°C		83	98		
		-40°C to 85°C	3 V	87	105		
		105°C		100	125		
$I_{LPM0, 100kHz}$ Low-power mode 0 (LPM0) current, see Note 3	$f_{MCLK} = 0$ MHz, $f_{SMCLK} = f_{DCO(0,0)} \approx 100$ kHz, $f_{ACLK} = 0$ Hz, RSELx = 0, DCOx = 0, CPUOFF = 1, SCG0 = 0, SCG1 = 0, OSCOFF = 1	-40°C to 85°C	2.2 V	37	49	μ A	
		105°C		50	62		
		-40°C to 85°C	3 V	40	55		
		105°C		57	73		
I_{LPM2} Low-power mode 2 (LPM2) current, see Note 4	$f_{MCLK} = f_{SMCLK} = 0$ MHz, $f_{DCO} = 1$ MHz, $f_{ACLK} = 32,768$ Hz, BCSCTL1 = CALBC1_1MHZ, DCOCTL = CALDCO_1MHZ, CPUOFF = 1, SCG0 = 0, SCG1 = 1, OSCOFF = 0	-40°C to 85°C	2.2 V	23	33	μ A	
		105°C		35	46		
		-40°C to 85°C	3 V	25	36		
		105°C		40	55		
$I_{LPM3, LFX1}$ Low-power mode 3 (LPM3) current, see Note 4	$f_{DCO} = f_{MCLK} = f_{SMCLK} = 0$ MHz, $f_{ACLK} = 32,768$ Hz, CPUOFF = 1, SCG0 = 1, SCG1 = 1, OSCOFF = 0	-40°C	2.2 V	0.8	1.2	μ A	
		25°C		1	1.3		
		85°C		4.6	7		
		105°C		14	24		
		-40°C	3 V	0.9	1.3		
		25°C		1.1	1.5		
		85°C		5.5	8		
		105°C		17	30		
$I_{LPM3, VLO}$ Low-power mode 3 (LPM3) current, see Note 4	$f_{DCO} = f_{MCLK} = f_{SMCLK} = 0$ MHz, f_{ACLK} from internal LF oscillator (VLO), CPUOFF = 1, SCG0 = 1, SCG1 = 1, OSCOFF = 0	-40°C	2.2 V	0.4	1.0	μ A	
		25°C		0.5	1.0		
		85°C		4.3	6.5		
		105°C		14	24		
		-40°C	3 V	0.6	1.2		
		25°C		0.6	1.2		
		85°C		5	7.5		
		105°C		16.5	29.5		

- NOTES: 1. All inputs are tied to 0 V or V_{CC} . Outputs do not source or sink any current.
 2. The currents are characterized with a micro crystal CC4V-T1A SMD crystal with a load capacitance of 9 pF. The internal and external load capacitance is chosen to closely match the required 9 pF.
 3. Current for Brownout and WDT+ is included. The WDT+ is clocked by SMCLK.
 4. Current for Brownout and WDT+ is included. The WDT+ is clocked by ACLK.



electrical characteristics over recommended ranges of supply voltage and operating free-air temperature (unless otherwise noted)

low-power mode supply current into V_{CC} excluding external current (see Notes 1 and 2) (continued)

PARAMETER	TEST CONDITIONS	T_A	V_{CC}	MIN	TYP	MAX	UNIT
I_{LPM4}	Low-power mode 4 (LPM4) current, see Note 3	$f_{DCO} = f_{MCLK} = f_{SMCLK} = 0$ MHz, $f_{ACLK} = 0$ Hz, CPUOFF = 1, SCG0 = 1, SCG1 = 1, OSCOFF = 1	2.2 V	-40°C	0.1	0.5	μ A
				25°C	0.1	0.5	
				85°C	4	6	
				105°C	13	23	
I_{LPM4}	Low-power mode 4 (LPM4) current, see Note 3	$f_{DCO} = f_{MCLK} = f_{SMCLK} = 0$ MHz, $f_{ACLK} = 0$ Hz, CPUOFF = 1, SCG0 = 1, SCG1 = 1, OSCOFF = 1	3 V	-40°C	0.2	0.5	μ A
				25°C	0.2	0.5	
				85°C	4.7	7	
				105°C	14	24	

- NOTES: 1. All inputs are tied to 0 V or V_{CC} . Outputs do not source or sink any current.
2. The currents are characterized with a micro crystal CC4V-T1A SMD crystal with a load capacitance of 9 pf. The internal and external load capacitance is chosen to closely match the required 9 pf.
3. Current for Brownout included.

typical characteristics - LPM4 current

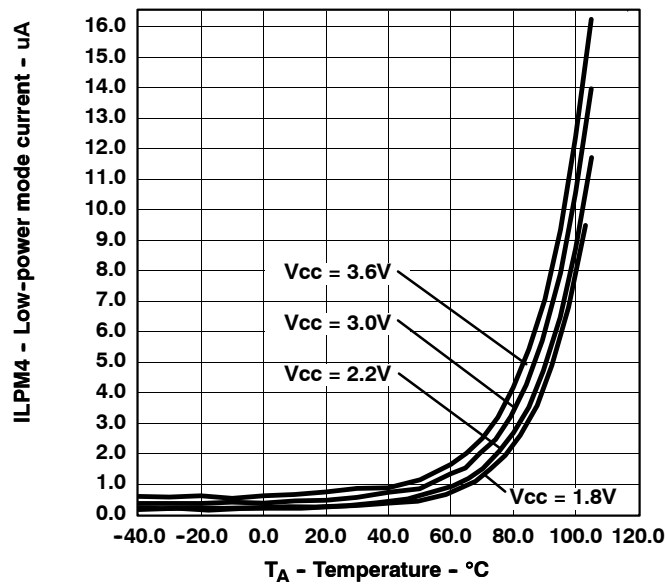

Figure 4. I_{LPM4} - LPM4 Current vs. Temperature

MSP430F2618-EP MIXED SIGNAL MICROCONTROLLER

SLAS632 - DECEMBER 2008

Schmitt-trigger inputs - ports P1 through P8, RST/ $\overline{\text{NMI}}$, JTAG, XIN, and XT2IN (see Note 1)

PARAMETER	TEST CONDITIONS	V _{CC}	MIN	TYP	MAX	UNIT
V _{IT+} Positive-going input threshold voltage			0.45 V _{CC}		0.75 V _{CC}	V
		2.2 V	1.0		1.65	
		3 V	1.35		2.25	
V _{IT-} Negative-going input threshold voltage			0.25 V _{CC}		0.55 V _{CC}	V
		2.2 V	0.55		1.2	
		3 V	0.75		1.65	
V _{hys} Input voltage hysteresis (V _{IT+} - V _{IT-})		2.2 V	0.2		1.0	V
		3 V	0.3		1.0	
R _{Pull} Pullup/pulldown resistor	Pullup: V _{IN} = V _{SS} , Pulldown: V _{IN} = V _{CC}		20	35	50	kΩ
C _I Input capacitance	V _{IN} = V _{SS} or V _{CC}			5		pF

NOTE 1: XIN and XT2IN in bypass mode only.

inputs - ports P1 and P2

PARAMETER	TEST CONDITIONS	V _{CC}	MIN	MAX	UNIT
t _{int} External interrupt timing	Port P1, P2: P1.x to P2.x, external trigger pulse width to set the interrupt flag (see Note 1)	2.2 V/3 V	20		ns

NOTE 1: The external signal sets the interrupt flag every time the minimum t_(int) parameters are met. It may be set with trigger signals shorter than t_(int).

leakage current - ports P1 through P8 (see Note 1 and 2)

PARAMETER	TEST CONDITIONS	V _{CC}	MIN	MAX	UNIT
I _{lkg} (P _{x,x}) High-impedance leakage current	see Notes 1 and 2	2.2 V/3 V		±50	nA

NOTES: 1. The leakage current is measured with V_{SS} or V_{CC} applied to the corresponding pin(s), unless otherwise noted.
2. The leakage of digital port pins is measured individually. The port pin is selected for input and the pullup/pulldown resistor is disabled.



electrical characteristics over recommended ranges of supply voltage and operating free-air temperature (unless otherwise noted) (continued)

standard inputs - $\overline{\text{RST}}$ /NMI

PARAMETER		TEST CONDITIONS	V _{CC}	MIN	MAX	UNIT
V _{IL}	Low-level input voltage		2.2 V/3 V	V _{SS}	V _{SS} +0.6	V
V _{IH}	High-level input voltage		2.2 V/3 V	0.8×V _{CC}	V _{CC}	V

outputs - ports P1 through P8

PARAMETER		TEST CONDITIONS	V _{CC}	MIN	MAX	UNIT
V _{OH}	High-level output voltage	I _{OH(max)} = -1.5 mA (see Note 1)	2.2 V	V _{CC} -0.25	V _{CC}	V
		I _{OH(max)} = -6 mA (see Note 2)		V _{CC} -0.6	V _{CC}	
		I _{OH(max)} = -1.5 mA (see Note 1)	3 V	V _{CC} -0.25	V _{CC}	
		I _{OH(max)} = -6 mA (see Note 2)		V _{CC} -0.6	V _{CC}	
V _{OL}	Low-level output voltage	I _{OL(max)} = 1.5 mA (see Note 1)	2.2 V	V _{SS}	V _{SS} +0.25	V
		I _{OL(max)} = 6 mA (see Note 2)		V _{SS}	V _{SS} +0.6	
		I _{OL(max)} = 1.5 mA (see Note 1)	3 V	V _{SS}	V _{SS} +0.25	
		I _{OL(max)} = 6 mA (see Note 2)		V _{SS}	V _{SS} +0.6	

- NOTES: 1. The maximum total current, I_{OH(max)} and I_{OL(max)}, for all outputs combined, should not exceed ±12 mA to satisfy the maximum voltage drop specified.
 2. The maximum total current, I_{OH(max)} and I_{OL(max)}, for all outputs combined, should not exceed ±48 mA to satisfy the maximum voltage drop specified.

output frequency - ports P1 through P8

PARAMETER		TEST CONDITIONS	V _{CC}	MIN	TYP	MAX	UNIT
f _{Px.y}	Port output frequency with load	P1.4/SMCLK, C _L = 20 pF, R _L = 1 kΩ (see Notes 1 and 2)	2.2 V	DC		10	MHz
			3.0 V	DC		12	
f _{Port_CLK}	Clock output frequency	P2.0/ACLK/CA2, P1.4/SMCLK, C _L = 20 pF (see Note 2)	2.2 V	DC		12	MHz
			3.3 V	DC		16	
t _(Xdc)	Duty cycle of output frequency	P5.6/ACLK, C _L = 20 pF, LF mode		30	50	70	%
		P5.6/ACLK, C _L = 20 pF, XT1 mode		40	50	60	
		P5.4/MCLK, C _L = 20 pF, XT1 mode		40		60	
		P5.4/MCLK, C _L = 20 pF, DCO		50% - 15 ns	50	50% + 15 ns	
		P1.4/SMCLK, C _L = 20 pF, XT2 mode		40		60	%
		P1.4/SMCLK, C _L = 20 pF, DCO		50% - 15 ns		50% + 15 ns	

- NOTES: 1. A resistive divider with 2 times 0.5 kΩ between V_{CC} and V_{SS} is used as load. The output is connected to the center tap of the divider.
 2. The output voltage reaches at least 10% and 90% V_{CC} at the specified toggle frequency.

MSP430F2618-EP MIXED SIGNAL MICROCONTROLLER

SLAS632 - DECEMBER 2008

electrical characteristics over recommended ranges of supply voltage and operating free-air temperature (unless otherwise noted) (continued)

typical characteristics - outputs

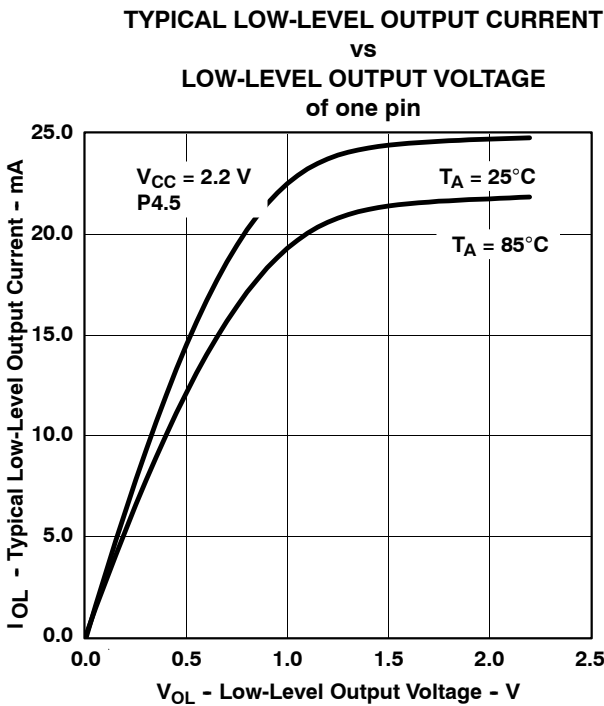

Figure 5

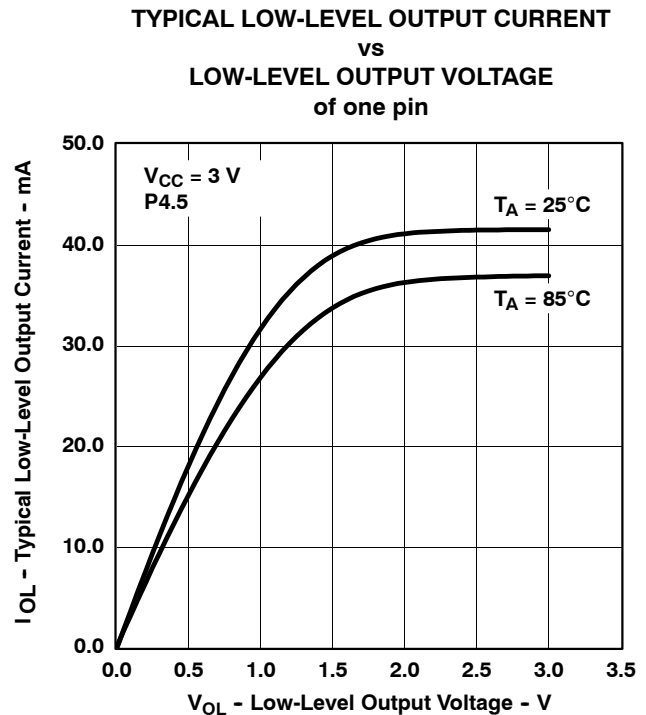

Figure 6

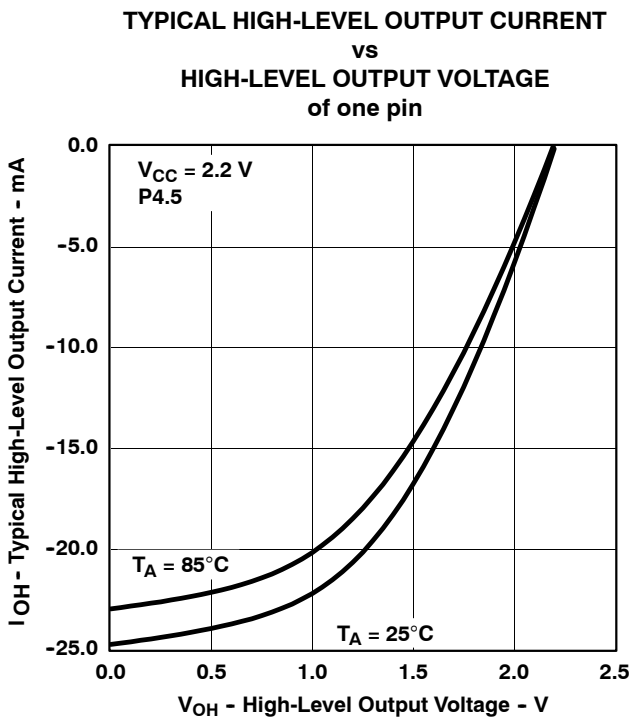

Figure 7

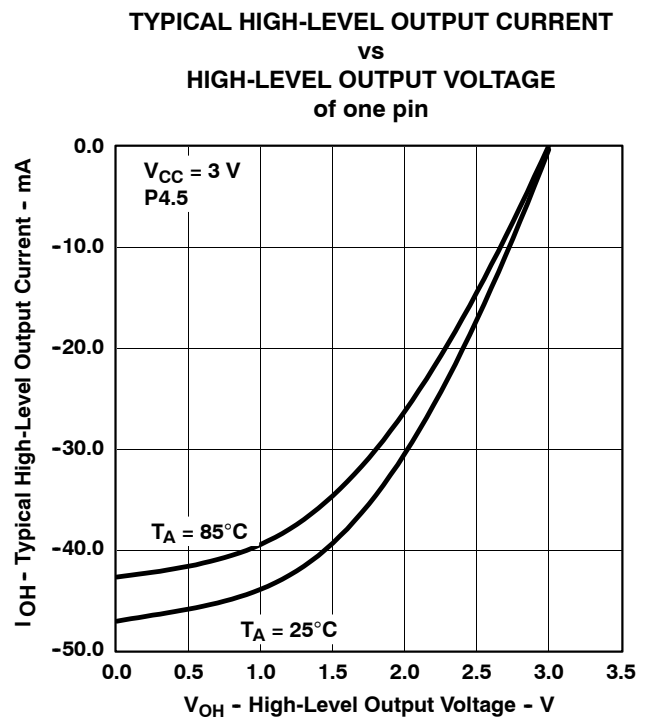

Figure 8

electrical characteristics over recommended ranges of supply voltage and operating free-air temperature (unless otherwise noted) (continued)

POR/brownout reset (BOR) (see Notes 1 and 2)

PARAMETER		TEST CONDITIONS	V _{CC}	MIN	TYP	MAX	UNIT
V _{CC(start)}	operating voltage	dV _{CC} /dt ≤ 3 V/s		0.7 × V _(B_IT-)			V
V _(B_IT-)	negative going V _{CC} reset threshold voltage	dV _{CC} /dt ≤ 3 V/s		1.71			V
V _{hys(B_IT-)}	V _{CC} reset threshold hysteresis	dV _{CC} /dt ≤ 3 V/s		70	130	210	mV
t _{d(BOR)}	BOR reset release delay time			2000			μs
t _{reset}	Pulse length at RST/NMI pin to accept a reset		2.2 V / 3 V	2			μs

- NOTES: 1. The current consumption of the brownout module is included in the I_{CC} current consumption data. The voltage level V_(B_IT-) + V_{hys(B_IT-)} is ≤ 1.8 V.
2. During power up, the CPU begins code execution following a period of t_{d(BOR)} after V_{CC} = V_(B_IT-) + V_{hys(B_IT-)}. The default DCO settings must not be changed until V_{CC} ≥ V_{CC(MIN)}, where V_{CC(min)} is the minimum supply voltage for the desired operating frequency.

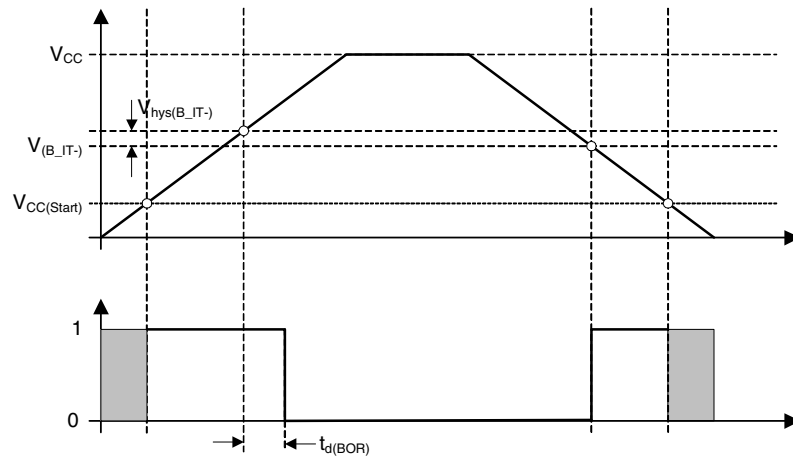

Figure 9. POR/Brownout Reset (BOR) vs Supply Voltage

MSP430F2618-EP MIXED SIGNAL MICROCONTROLLER

SLAS632 - DECEMBER 2008

electrical characteristics over recommended ranges of supply voltage and operating free-air temperature (unless otherwise noted) (continued)

typical characteristics - POR/brownout reset (BOR)

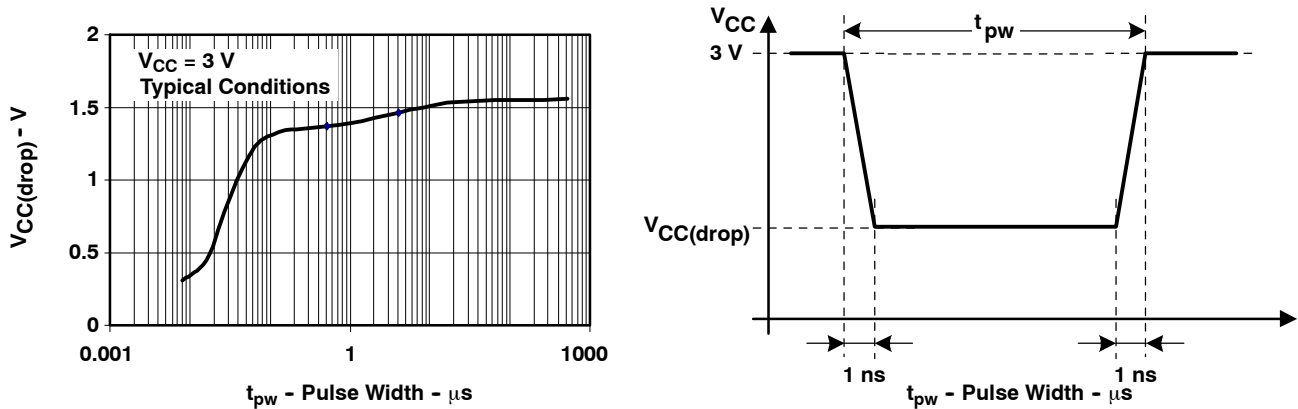

Figure 10. $V_{CC(drop)}$ Level With a Square Voltage Drop to Generate a POR/Brownout Signal

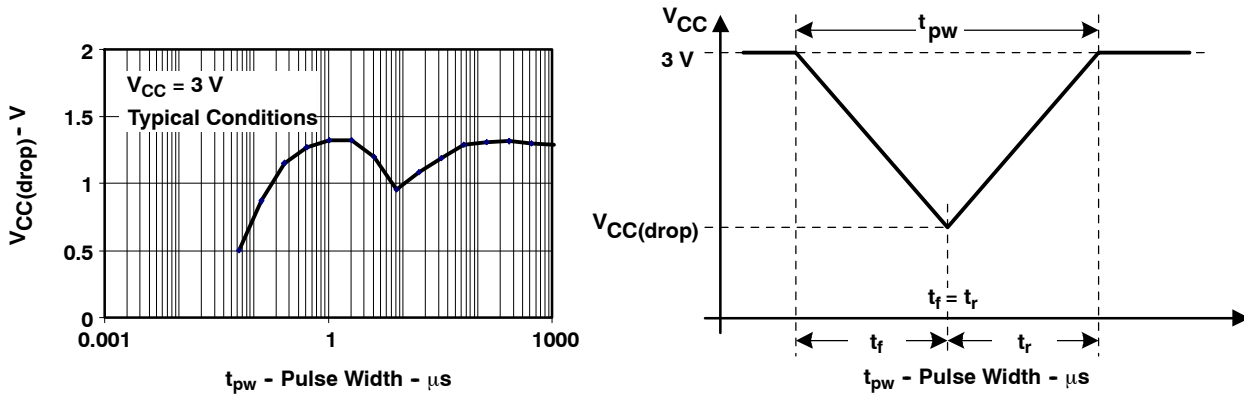

Figure 11. $V_{CC(drop)}$ Level With a Triangle Voltage Drop to Generate a POR/Brownout Signal

electrical characteristics over recommended ranges of supply voltage and operating free-air temperature (unless otherwise noted) (continued)

SVS (supply voltage supervisor/monitor)

PARAMETER	TEST CONDITIONS	MIN	TYP	MAX	UNIT	
$t_{(SVSR)}$	$dV_{CC}/dt > 30 \text{ V/ms}$ (see Figure 12)	5		150	μs	
	$dV_{CC}/dt \leq 30 \text{ V/ms}$			2000		
$t_{d(SVson)}$	SVSON, switch from VLD = 0 to VLD \neq 0, $V_{CC} = 3 \text{ V}$	20		150	μs	
t_{settle}	VLD \neq 0 [†]			12	μs	
$V_{(SVSstart)}$	VLD \neq 0, $V_{CC}/dt \leq 3 \text{ V/s}$ (see Figure 12)		1.55	1.7	V	
$V_{\text{hys}(SVS_IT-)}$	$V_{CC}/dt \leq 3 \text{ V/s}$ (see Figure 12)	VLD = 1	70	120	210	mV
		VLD = 2 to 14	$V_{(SVS_IT-)} \times 0.004$		$V_{(SVS_IT-)} \times 0.016$	V
	$V_{CC}/dt \leq 3 \text{ V/s}$ (see Figure 12), External voltage applied on A7	VLD = 15	4.4		20	mV
$V_{(SVS_IT-)}$	$V_{CC}/dt \leq 3 \text{ V/s}$ (see Figure 12 and Figure 13)	VLD = 1	1.8	1.9	2.05	V
		VLD = 2	1.94	2.1	2.25	
		VLD = 3	2.05	2.2	2.37	
		VLD = 4	2.14	2.3	2.48	
		VLD = 5	2.24	2.4	2.6	
		VLD = 6	2.33	2.5	2.71	
		VLD = 7	2.46	2.65	2.86	
		VLD = 8	2.58	2.8	3	
		VLD = 9	2.69	2.9	3.13	
		VLD = 10	2.83	3.05	3.29	
		VLD = 11	2.94	3.2	3.42	
		VLD = 12	3.11	3.35	3.61 [†]	
		VLD = 13	3.24	3.5	3.76 [†]	
		VLD = 14	3.43	3.7 [†]	3.99 [†]	
	$V_{CC}/dt \leq 3 \text{ V/s}$ (see Figure 12 and Figure 13), External voltage applied on A7	VLD = 15	1.1	1.2	1.3	
$I_{CC(SVS)}$ (see Note 1)	VLD \neq 0, $V_{CC} = 2.2 \text{ V}/3 \text{ V}$		10	15	μA	

[†] The recommended operating voltage range is limited to 3.6 V.

[‡] t_{settle} is the settling time that the comparator o/p needs to have a stable level after VLD is switched VLD \neq 0 to a different VLD value between 2 and 15. The overdrive is assumed to be > 50 mV.

NOTE 1: The current consumption of the SVS module is not included in the I_{CC} current consumption data.

typical characteristics

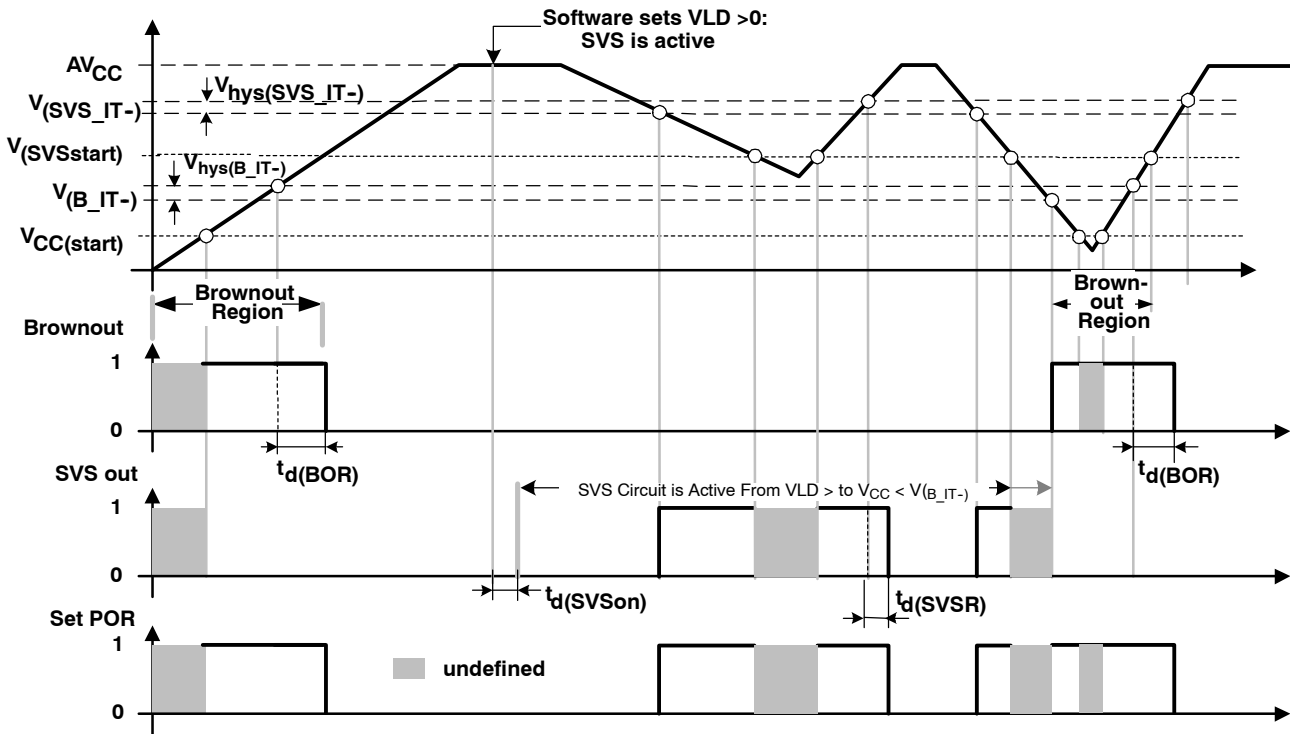

Figure 12. SVS Reset (SVSR) vs Supply Voltage

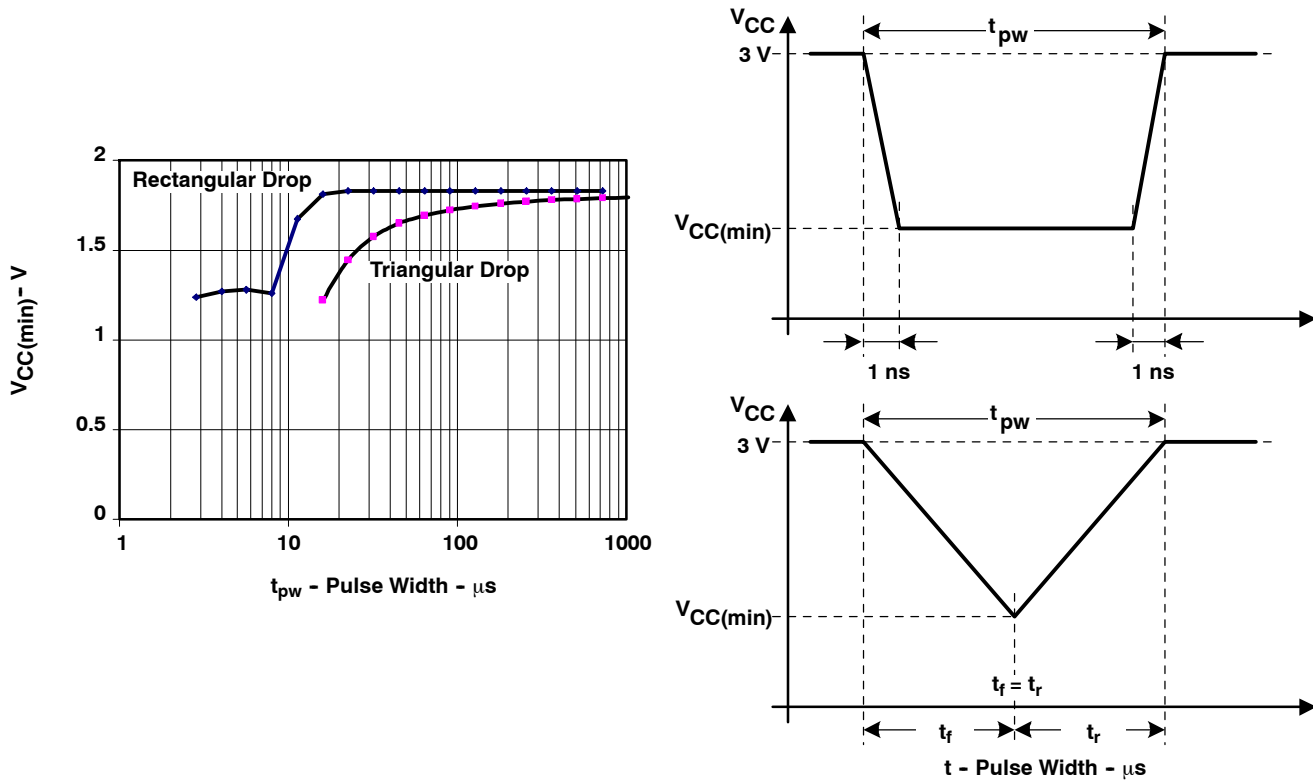

Figure 13. $V_{CC(min)}$: Square Voltage Drop and Triangle Voltage Drop to Generate an SVS Signal ($VLD = 1$)

electrical characteristics over recommended ranges of supply voltage and operating free-air temperature (unless otherwise noted) (continued)

main DCO characteristics

- All ranges selected by RSELx overlap with RSELx + 1: RSELx = 0 overlaps RSELx = 1, ... RSELx = 14 overlaps RSELx = 15.
- DCO control bits DCOx have a step size as defined by parameter S_{DCO}.
- Modulation control bits MODx select how often f_{DCO(RSEL,DCO+1)} is used within the period of 32 DCOCLK cycles. The frequency f_{DCO(RSEL,DCO)} is used for the remaining cycles. The frequency is an average equal to:

$$f_{\text{average}} = \frac{32 \times f_{\text{DCO(RSEL,DCO)}} \times f_{\text{DCO(RSEL,DCO+1)}}}{\text{MOD} \times f_{\text{DCO(RSEL,DCO)}} + (32 - \text{MOD}) \times f_{\text{DCO(RSEL,DCO+1)}}}$$

DCO frequency

PARAMETER	TEST CONDITIONS	V _{CC}	MIN	TYP	MAX	UNIT
V _{CC} Supply voltage	RSELx < 14		1.8		3.6	V
	RSELx = 14		2.2		3.6	
	RSELx = 15		3.0		3.6	
f _{DCO(0,0)} DCO frequency (0, 0)	RSELx = 0, DCOx = 0, MODx = 0	2.2 V/3 V	0.06		0.14	MHz
f _{DCO(0,3)} DCO frequency (0, 3)	RSELx = 0, DCOx = 3, MODx = 0	2.2 V/3 V	0.07		0.17	MHz
f _{DCO(1,3)} DCO frequency (1, 3)	RSELx = 1, DCOx = 3, MODx = 0	2.2 V/3 V	0.10		0.20	MHz
f _{DCO(2,3)} DCO frequency (2, 3)	RSELx = 2, DCOx = 3, MODx = 0	2.2 V/3 V	0.14		0.28	MHz
f _{DCO(3,3)} DCO frequency (3, 3)	RSELx = 3, DCOx = 3, MODx = 0	2.2 V/3 V	0.20		0.40	MHz
f _{DCO(4,3)} DCO frequency (4, 3)	RSELx = 4, DCOx = 3, MODx = 0	2.2 V/3 V	0.28		0.54	MHz
f _{DCO(5,3)} DCO frequency (5, 3)	RSELx = 5, DCOx = 3, MODx = 0	2.2 V/3 V	0.39		0.77	MHz
f _{DCO(6,3)} DCO frequency (6, 3)	RSELx = 6, DCOx = 3, MODx = 0	2.2 V/3 V	0.54		1.06	MHz
f _{DCO(7,3)} DCO frequency (7, 3)	RSELx = 7, DCOx = 3, MODx = 0	2.2 V/3 V	0.80		1.50	MHz
f _{DCO(8,3)} DCO frequency (8, 3)	RSELx = 8, DCOx = 3, MODx = 0	2.2 V/3 V	1.10		2.10	MHz
f _{DCO(9,3)} DCO frequency (9, 3)	RSELx = 9, DCOx = 3, MODx = 0	2.2 V/3 V	1.60		3.00	MHz
f _{DCO(10,3)} DCO frequency (10, 3)	RSELx = 10, DCOx = 3, MODx = 0	2.2 V/3 V	2.50		4.30	MHz
f _{DCO(11,3)} DCO frequency (11, 3)	RSELx = 11, DCOx = 3, MODx = 0	2.2 V/3 V	3.00		5.50	MHz
f _{DCO(12,3)} DCO frequency (12, 3)	RSELx = 12, DCOx = 3, MODx = 0	2.2 V/3 V	4.30		7.30	MHz
f _{DCO(13,3)} DCO frequency (13, 3)	RSELx = 13, DCOx = 3, MODx = 0	2.2 V/3 V	6.00		9.60	MHz
f _{DCO(14,3)} DCO frequency (14, 3)	RSELx = 14, DCOx = 3, MODx = 0	2.2 V/3 V	8.60		13.9	MHz
f _{DCO(15,3)} DCO frequency (15, 3)	RSELx = 15, DCOx = 3, MODx = 0	3 V	12.0		18.5	MHz
f _{DCO(15,7)} DCO frequency (15, 7)	RSELx = 15, DCOx = 7, MODx = 0	3 V	16.0		26.0	MHz
S _{RSEL} Frequency step between range RSEL and RSEL+1	S _{RSEL} = f _{DCO(RSEL+1,DCO)} /f _{DCO(RSEL,DCO)}	2.2 V/3 V			1.55	ratio
S _{DCO} Frequency step between tap DCO and DCO+1	S _{DCO} = f _{DCO(RSEL,DCO+1)} /f _{DCO(RSEL,DCO)}	2.2 V/3 V	1.05	1.08	1.12	ratio
Duty cycle	Measured at P1.4/SMCLK	2.2 V/3 V	40	50	60	%

MSP430F2618-EP MIXED SIGNAL MICROCONTROLLER

SLAS632 - DECEMBER 2008

electrical characteristics over recommended ranges of supply voltage and operating free-air temperature (unless otherwise noted) (continued)

calibrated DCO frequencies - tolerance at calibration

PARAMETER	TEST CONDITIONS	T _A	V _{CC}	MIN	TYP	MAX	UNIT
Frequency tolerance at calibration		25°C	3 V	-1	±0.2	+1	%
f _{CAL(1MHz)} 1-MHz calibration value	BCSCTL1 = CALBC1_1MHZ, DCOCTL = CALDCO_1MHZ, Gating time: 5 ms	25°C	3 V	0.990	1	1.010	MHz
f _{CAL(8MHz)} 8-MHz calibration value	BCSCTL1 = CALBC1_8MHZ, DCOCTL = CALDCO_8MHZ, Gating time: 5 ms	25°C	3 V	7.920	8	8.080	MHz
f _{CAL(12MHz)} 12-MHz calibration value	BCSCTL1 = CALBC1_12MHZ, DCOCTL = CALDCO_12MHZ, Gating time: 5 ms	25°C	3 V	11.88	12	12.12	MHz
f _{CAL(16MHz)} 16-MHz calibration value	BCSCTL1 = CALBC1_16MHZ, DCOCTL = CALDCO_16MHZ, Gating time: 2 ms	25°C	3 V	15.84	16	16.16	MHz

calibrated DCO frequencies - tolerance over temperature 0°C to 85°C

PARAMETER	TEST CONDITIONS	T _A	V _{CC}	MIN	TYP	MAX	UNIT
1-MHz tolerance over temperature		0°C to 85°C	3 V	-2.5	±0.5	+2.5	%
8-MHz tolerance over temperature		0°C to 85°C	3 V	-2.5	±1.0	+2.5	%
12-MHz tolerance over temperature		0°C to 85°C	3 V	-2.5	±1.0	+2.5	%
16-MHz tolerance over temperature		0°C to 85°C	3 V	-3.0	±2.0	+3.0	%
f _{CAL(1MHz)} 1-MHz calibration value	BCSCTL1 = CALBC1_1MHZ, DCOCTL = CALDCO_1MHZ, Gating time: 5 ms	0°C to 85°C	2.2 V	0.970	1	1.030	MHz
			3 V	0.975	1	1.025	
			3.6 V	0.970	1	1.030	
f _{CAL(8MHz)} 8-MHz calibration value	BCSCTL1 = CALBC1_8MHZ, DCOCTL = CALDCO_8MHZ, Gating time: 5 ms	0°C to 85°C	2.2 V	7.760	8	8.400	MHz
			3 V	7.800	8	8.200	
			3.6 V	7.600	8	8.240	
f _{CAL(12MHz)} 12-MHz calibration value	BCSCTL1 = CALBC1_12MHZ, DCOCTL = CALDCO_12MHZ, Gating time: 5 ms	0°C to 85°C	2.2 V	11.64	12	12.36	MHz
			3 V	11.64	12	12.36	
			3.6 V	11.64	12	12.36	
f _{CAL(16MHz)} 16-MHz calibration value	BCSCTL1 = CALBC1_16MHZ, DCOCTL = CALDCO_16MHZ, Gating time: 2 ms	0°C to 85°C	3 V	15.52	16	16.48	MHz
			3.6 V	15.00	16	16.48	



electrical characteristics over recommended ranges of supply voltage and operating free-air temperature (unless otherwise noted) (continued)

calibrated DCO frequencies - tolerance over supply voltage V_{CC}

PARAMETER	TEST CONDITIONS	T_A	V_{CC}	MIN	TYP	MAX	UNIT
1-MHz tolerance over V_{CC}		25°C	1.8 V to 3.6 V	-3	±2	+3	%
8-MHz tolerance over V_{CC}		25°C	1.8 V to 3.6 V	-3	±2	+3	%
12-MHz tolerance over V_{CC}		25°C	2.2 V to 3.6 V	-3	±2	+3	%
16-MHz tolerance over V_{CC}		25°C	3.0 V to 3.6 V	-6	±2	+3	%
$f_{CAL(1MHz)}$ 1-MHz calibration value	BCSCTL1 = CALBC1_1MHZ, DCOCTL = CALDCO_1MHZ, Gating time: 5 ms	25°C	1.8 V to 3.6 V	0.970	1	1.030	MHz
$f_{CAL(8MHz)}$ 8-MHz calibration value	BCSCTL1 = CALBC1_8MHZ, DCOCTL = CALDCO_8MHZ, Gating time: 5 ms	25°C	1.8 V to 3.6 V	7.760	8	8.240	MHz
$f_{CAL(12MHz)}$ 12-MHz calibration value	BCSCTL1 = CALBC1_12MHZ, DCOCTL = CALDCO_12MHZ, Gating time: 5 ms	25°C	2.2 V to 3.6 V	11.64	12	12.36	MHz
$f_{CAL(16MHz)}$ 16-MHz calibration value	BCSCTL1 = CALBC1_16MHZ, DCOCTL = CALDCO_16MHZ, Gating time: 2 ms	25°C	3.0 V to 3.6 V	15.00	16	16.48	MHz

calibrated DCO frequencies - overall tolerance

PARAMETER	TEST CONDITIONS	T_A	V_{CC}	MIN	TYP	MAX	UNIT
1-MHz tolerance overall		-40°C to 105°C	1.8 V to 3.6 V	-5	±2	+5	%
8-MHz tolerance overall		-40°C to 105°C	1.8 V to 3.6 V	-5	±2	+5	%
12-MHz tolerance overall		-40°C to 105°C	2.2 V to 3.6 V	-5	±2	+5	%
16-MHz tolerance overall		-40°C to 105°C	3 V to 3.6 V	-6	±3	+6	%
$f_{CAL(1MHz)}$ 1-MHz calibration value	BCSCTL1 = CALBC1_1MHZ, DCOCTL = CALDCO_1MHZ, Gating time: 5ms	-40°C to 105°C	1.8 V to 3.6 V	0.950	1	1.050	MHz
$f_{CAL(8MHz)}$ 8-MHz calibration value	BCSCTL1 = CALBC1_8MHZ, DCOCTL = CALDCO_8MHZ, Gating time: 5ms	-40°C to 105°C	1.8 V to 3.6 V	7.600	8	8.400	MHz
$f_{CAL(12MHz)}$ 12-MHz calibration value	BCSCTL1 = CALBC1_12MHZ, DCOCTL = CALDCO_12MHZ, Gating time: 5ms	-40°C to 105°C	2.2 V to 3.6 V	11.40	12	12.60	MHz
$f_{CAL(16MHz)}$ 16-MHz calibration value	BCSCTL1 = CALBC1_16MHZ, DCOCTL = CALDCO_16MHZ, Gating time: 2 ms	-40°C to 105°C	3 V to 3.6 V	15.00	16	17.00	MHz

MSP430F2618-EP MIXED SIGNAL MICROCONTROLLER

SLAS632 - DECEMBER 2008

electrical characteristics over recommended ranges of supply voltage and operating free-air temperature (unless otherwise noted) (continued)

typical characteristics - calibrated 1-MHz DCO frequency

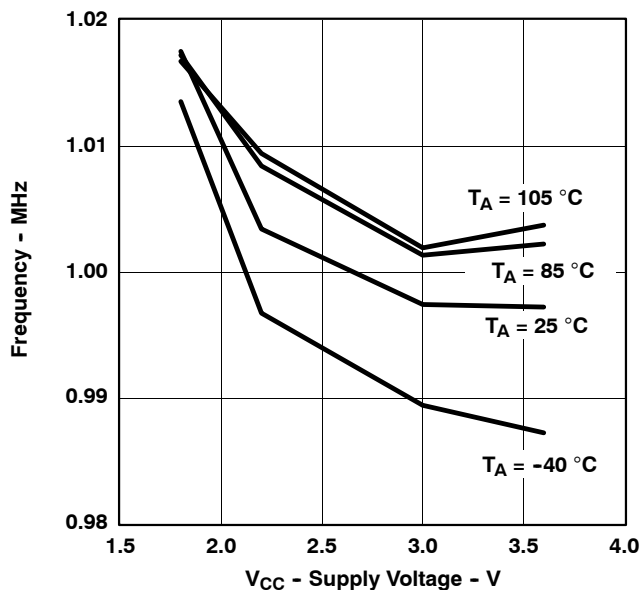

Figure 14. Calibrated 1-MHz Frequency vs V_{CC}

typical characteristics - calibrated 8-MHz DCO frequency

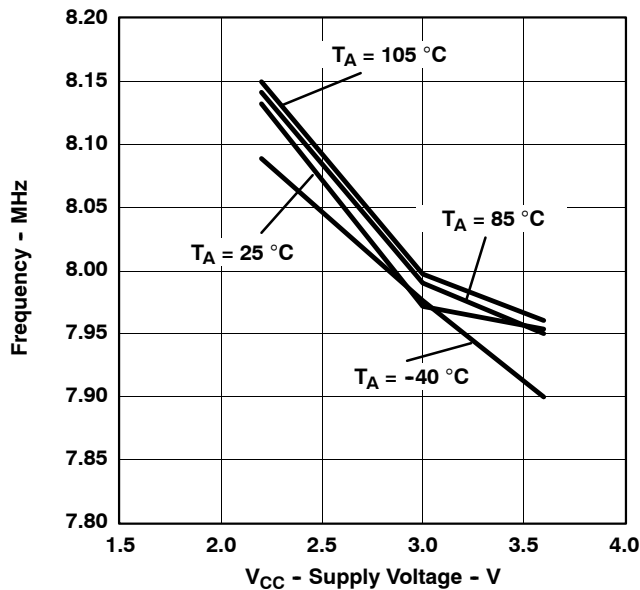

Figure 15. Calibrated 8-MHz Frequency vs V_{CC}

electrical characteristics over recommended ranges of supply voltage and operating free-air temperature (unless otherwise noted) (continued)

typical characteristics - calibrated 12-MHz DCO frequency

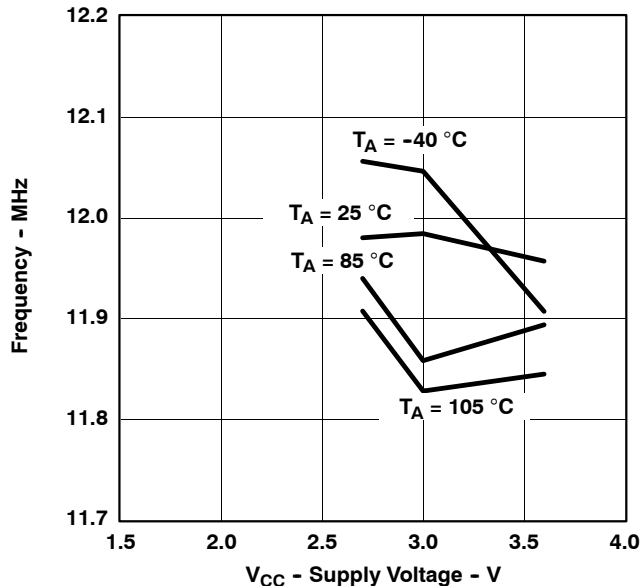

Figure 16. Calibrated 12-MHz Frequency vs V_{CC}

typical characteristics - calibrated 16-MHz DCO frequency

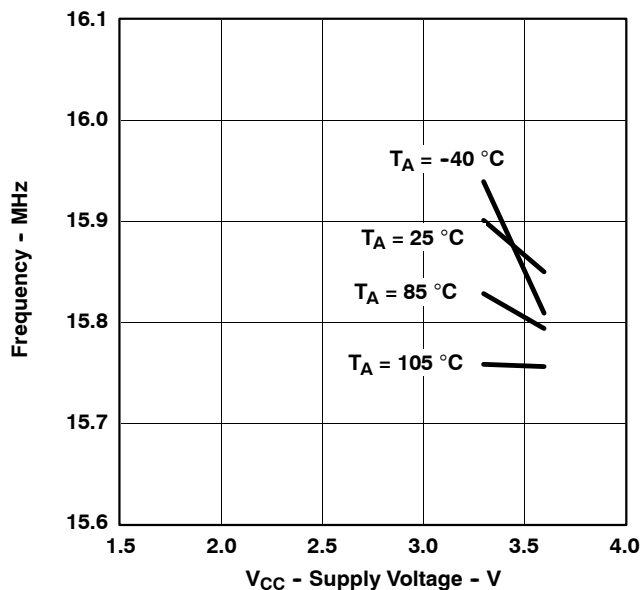

Figure 17. Calibrated 16-MHz Frequency vs V_{CC}

MSP430F2618-EP MIXED SIGNAL MICROCONTROLLER

SLAS632 - DECEMBER 2008

electrical characteristics over recommended ranges of supply voltage and operating free-air temperature (unless otherwise noted) (continued)

wake-up from low-power modes (LPM3/LPM4)

PARAMETER	TEST CONDITIONS	V _{CC}	MIN	TYP	MAX	UNIT
t _{DCO,LPM3/4} DCO clock wake-up time from LPM3/4 (see Note 1)	BCSCTL1= CALBC1_1MHZ, DCOCTL = CALDCO_1MHZ	2.2 V/3 V			2	μs
	BCSCTL1= CALBC1_8MHZ, DCOCTL = CALDCO_8MHZ	2.2 V/3 V			1.5	
	BCSCTL1= CALBC1_12MHZ, DCOCTL = CALDCO_12MHZ	2.2 V/3 V			1	
	BCSCTL1= CALBC1_16MHZ, DCOCTL = CALDCO_16MHZ	3 V			1	
t _{CPU,LPM3/4} CPU wake-up time from LPM3/4 (see Note 2)				1/f _{MCLK} + t _{Clock,LPM3/4}		

NOTES: 1. The DCO clock wake-up time is measured from the edge of an external wake-up signal (e.g., port interrupt) to the first clock edge observable externally on a clock pin (MCLK or SMCLK).
2. Parameter applicable only if DCOCLK is used for MCLK.

typical characteristics - DCO clock wake-up time from LPM3/4

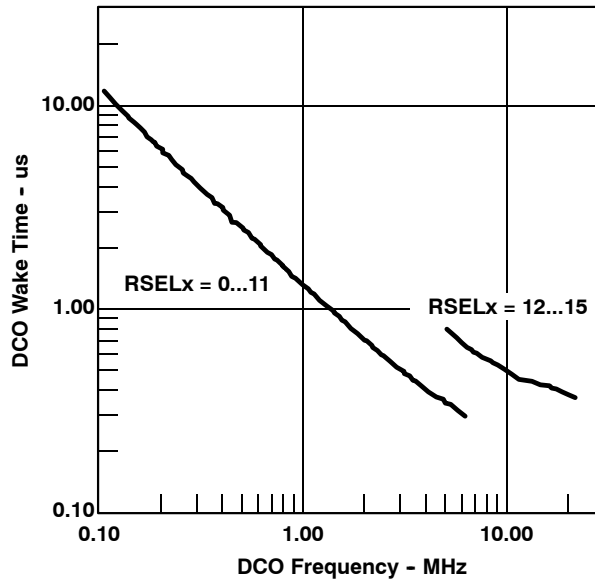

Figure 18. Clock Wake-Up Time From LPM3 vs DCO Frequency

electrical characteristics over recommended ranges of supply voltage and operating free-air temperature (unless otherwise noted) (continued)

DCO with external resistor R_{OSC} (see Note 1)

PARAMETER	TEST CONDITIONS	V_{CC}	TYP	UNIT	
$f_{DCO,R_{OSC}}$	DCO output frequency with R_{OSC}	DCOR = 1, RSELx = 4, DCOx = 3, MODx = 0, $T_A = 25^\circ C$	2.2 V 3 V	1.8 1.95	MHz
D_t	Temperature drift	DCOR = 1, RSELx = 4, DCOx = 3, MODx = 0	2.2 V/3 V	± 0.1	%/ $^\circ C$
D_V	Drift with V_{CC}	DCOR = 1, RSELx = 4, DCOx = 3, MODx = 0	2.2 V/3 V	10	%/V

NOTE 1: $R_{OSC} = 100\text{ k}\Omega$. Metal film resistor, type 0257. 0.6 watt with 1% tolerance and $T_K = \pm 50\text{ ppm}/^\circ C$.

typical characteristics - DCO with external resistor R_{OSC}

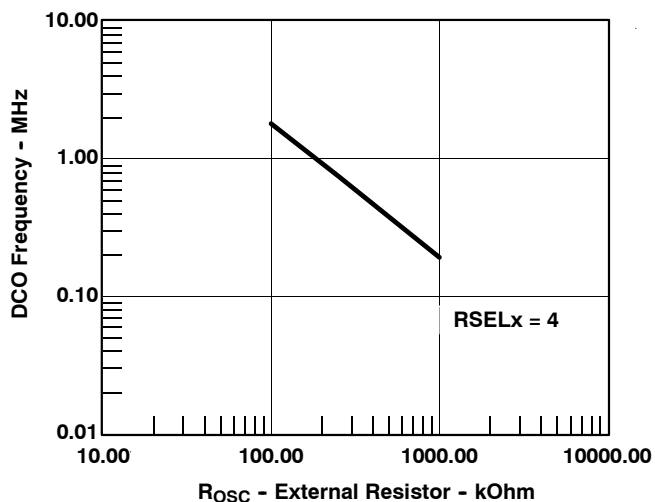

Figure 19. DCO Frequency vs R_{OSC} ,
 $V_{CC} = 2.2\text{ V}$, $T_A = 25^\circ C$

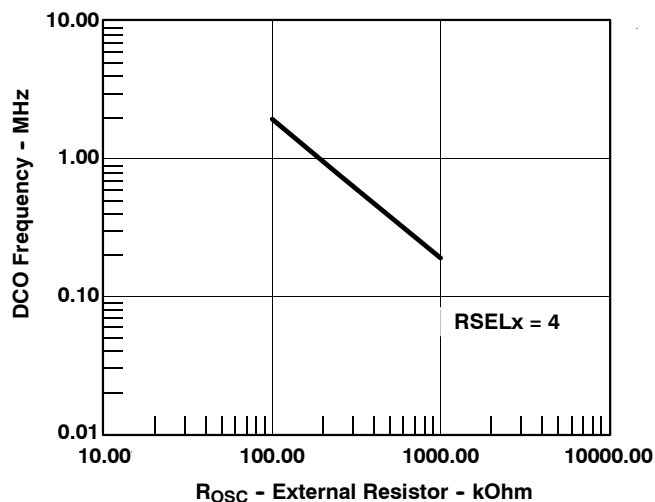

Figure 20. DCO Frequency vs R_{OSC} ,
 $V_{CC} = 3.0\text{ V}$, $T_A = 25^\circ C$

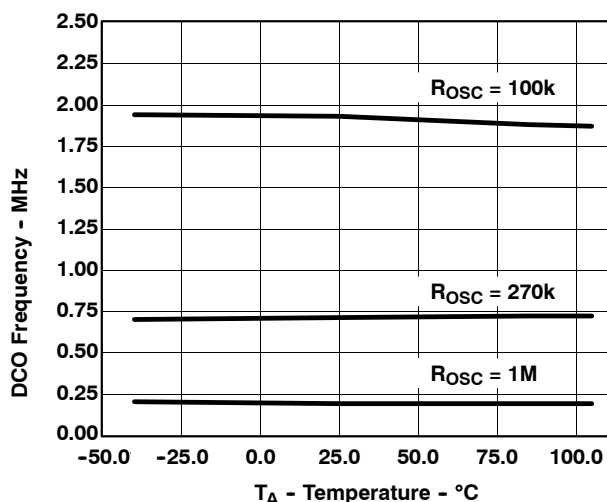

Figure 21. DCO Frequency vs Temperature,
 $V_{CC} = 3.0\text{ V}$

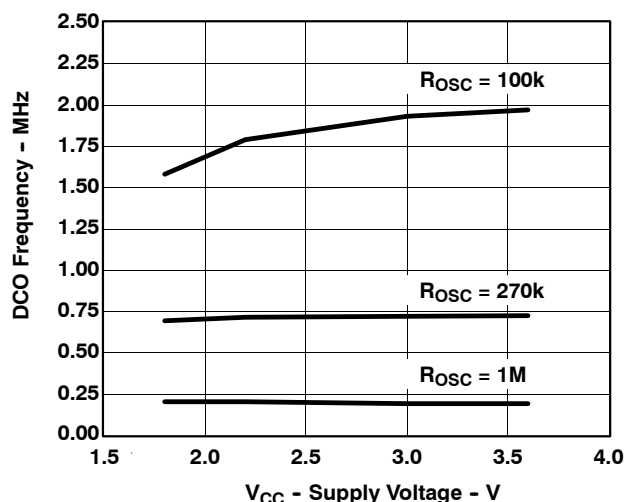

Figure 22. DCO Frequency vs V_{CC} ,
 $T_A = 25^\circ C$

MSP430F2618-EP MIXED SIGNAL MICROCONTROLLER

SLAS632 - DECEMBER 2008

electrical characteristics over recommended ranges of supply voltage and operating free-air temperature (unless otherwise noted) (continued)

crystal oscillator, LFXT1, low frequency modes (see Note 4)

PARAMETER		TEST CONDITIONS	V _{CC}	MIN	TYP	MAX	UNIT
f _{LFXT1,LF}	LFXT1 oscillator crystal frequency, LF mode 0/1	XTS = 0, LFXT1Sx = 0 or 1	1.8 V to 3.6 V		32,768		Hz
f _{LFXT1,LF,logic}	LFXT1 oscillator logic level square wave input frequency, LF mode	XTS = 0, LFXT1Sx = 3, XCAPx = 0	1.8 V to 3.6 V	10,000	32,768	50,000	Hz
OA _{LF}	Oscillation allowance for LF crystals	XTS = 0, LFXT1Sx = 0, f _{LFXT1,LF} = 32,768 kHz, C _{L,eff} = 6 pF			500		kΩ
		XTS = 0, LFXT1Sx = 0; f _{LFXT1,LF} = 32,768 kHz, C _{L,eff} = 12 pF			200		
C _{L,eff}	Integrated effective load capacitance, LF mode (see Note 1)	XTS = 0, XCAPx = 0			1		pF
		XTS = 0, XCAPx = 1			5.5		
		XTS = 0, XCAPx = 2			8.5		
		XTS = 0, XCAPx = 3			11		
Duty cycle	LF mode	XTS = 0, Measured at P1.4/ACLK, f _{LFXT1,LF} = 32,768 Hz	2.2 V/3 V	30	50	70	%
f _{Fault,LF}	Oscillator fault frequency, LF mode (see Note 3)	XTS = 0, LFXT1Sx = 3, XCAPx = 0 (see Note 2)	2.2 V/3 V	10		10,000	Hz

- NOTES: 1. Includes parasitic bond and package capacitance (approximately 2 pF per pin).
Since the PCB adds additional capacitance, it is recommended to verify the correct load by measuring the ACLK frequency. For a correct setup, the effective load capacitance should always match the specification of the used crystal.
2. Measured with logic level input frequency but also applies to operation with crystals.
3. Frequencies below the MIN specification set the fault flag, frequencies above the MAX specification do not set the fault flag, and frequencies in between might set the flag.
4. To improve EMI on the LFXT1 oscillator the following guidelines should be observed.
- Keep the trace between the device and the crystal as short as possible.
 - Design a good ground plane around the oscillator pins.
 - Prevent crosstalk from other clock or data lines into oscillator pins XIN and XOUT.
 - Avoid running PCB traces under or adjacent to the XIN and XOUT pins.
 - Use assembly materials and praxis to avoid any parasitic load on the oscillator XIN and XOUT pins.
 - If conformal coating is used, ensure that it does not induce capacitive/resistive leakage between the oscillator pins.
 - Do not route the XOUT line to the JTAG header to support the serial programming adapter as shown in other documentation. This signal is no longer required for the serial programming adapter.
5. Applies only if using an external logic-level clock source. Not applicable when using a crystal or resonator.



electrical characteristics over recommended ranges of supply voltage and operating free-air temperature (unless otherwise noted) (continued)

internal very low power, low frequency oscillator (VLO)

PARAMETER		TEST CONDITIONS	T _A	V _{CC}	MIN	TYP	MAX	UNIT
f _{VLO}	VLO frequency		-40°C to 85°C	2.2 V/3 V	4	12	20	kHz
			105°C				22	
df _{VLO} /dT	VLO frequency temperature drift	See Note 1		2.2 V/3 V	0.5			%/°C
df _{VLO} /dV _{CC}	VLO frequency supply voltage drift	See Note 2	25°C	1.8 V - 3.6V	4			%/V

- NOTES: 1. Calculated using the box method:
I version: $(\text{MAX}(-40^\circ\text{C to } 85^\circ\text{C}) - \text{MIN}(-40^\circ\text{C to } 85^\circ\text{C})) / \text{MIN}(-40^\circ\text{C to } 85^\circ\text{C}) / (85^\circ\text{C} - (-40^\circ\text{C}))$
T version: $(\text{MAX}(-40^\circ\text{C to } 105^\circ\text{C}) - \text{MIN}(-40^\circ\text{C to } 105^\circ\text{C})) / \text{MIN}(-40^\circ\text{C to } 105^\circ\text{C}) / (105^\circ\text{C} - (-40^\circ\text{C}))$
2. Calculated using the box method: $(\text{MAX}(1.8 \text{ V to } 3.6\text{V}) - \text{MIN}(1.8\text{V to } 3.6\text{V})) / \text{MIN}(1.8 \text{ V to } 3.6\text{V}) / (3.6 \text{ V} - 1.8 \text{ V})$

MSP430F2618-EP MIXED SIGNAL MICROCONTROLLER

SLAS632 - DECEMBER 2008

electrical characteristics over recommended ranges of supply voltage and operating free-air temperature (unless otherwise noted) (continued)

crystal oscillator, LFXT1, high frequency modes (see Note 5)

PARAMETER		TEST CONDITIONS	V _{CC}	MIN	TYP	MAX	UNIT
f _{LFXT1,HF0}	LFXT1 oscillator crystal frequency, HF mode 0	XTS = 1, LFXT1Sx = 0, XCAPx = 0	1.8 V to 3.6 V	0.4		1	MHz
f _{LFXT1,HF1}	LFXT1 oscillator crystal frequency, HF mode 1	XTS = 1, LFXT1Sx = 1, XCAPx = 0	1.8 V to 3.6 V	1		4	MHz
f _{LFXT1,HF2}	LFXT1 oscillator crystal frequency, HF mode 2	XTS = 1, LFXT1Sx = 2, XCAPx = 0	1.8 V to 3.6 V	2		10	MHz
			2.2 V to 3.6 V	2		12	
			3 V to 3.6 V	2		16	
f _{LFXT1,HF,logic}	LFXT1 oscillator logic level square-wave input frequency, HF mode	XTS = 1, LFXT1Sx = 3, XCAPx = 0	1.8 V to 3.6 V	0.4		10	MHz
			2.2 V to 3.6 V	0.4		12	
			3 V to 3.6 V	0.4		16	
OA _{HF}	Oscillation allowance for HF crystals (see Figure 23 and Figure 24)	XTS = 1, XCAPx = 0, LFXT1Sx = 0, f _{LFXT1,HF} = 1 MHz, C _{L,eff} = 15 pF		2700			Ω
				800			
				300			
C _{L,eff}	Integrated effective load capacitance, HF mode (see Note 1)	XTS = 1, XCAPx = 0 (see Note 2)		1			pF
Duty cycle	HF mode	XTS = 1, XCAPx = 0, Measured at P1.4/ACLK, f _{LFXT1,HF} = 10 MHz	2.2 V/3 V	40	50	60	%
		XTS = 1, XCAPx = 0, Measured at P1.4/ACLK, f _{LFXT1,HF} = 16 MHz	2.2 V/3 V	40	50	60	
f _{Fault,HF}	Oscillator fault frequency, HF mode (see Note 4)	XTS = 1, LFXT1Sx = 3, XCAPx = 0 (see Note 3)	2.2 V/3 V	30		300	kHz

- NOTES: 1. Includes parasitic bond and package capacitance (approximately 2 pF per pin).
 Since the PCB adds additional capacitance it is recommended to verify the correct load by measuring the ACLK frequency. For a correct setup the effective load capacitance should always match the specification of the used crystal.
2. Requires external capacitors at both terminals. Values are specified by crystal manufacturers.
3. Measured with logic level input frequency but also applies to operation with crystals.
4. Frequencies below the MIN specification set the fault flag, frequencies above the MAX specification do not set the fault flag, and frequencies in between might set the flag.
5. To improve EMI on the LFXT1 oscillator the following guidelines should be observed.
- Keep the trace between the device and the crystal as short as possible.
 - Design a good ground plane around the oscillator pins.
 - Prevent crosstalk from other clock or data lines into oscillator pins XIN and XOUT.
 - Avoid running PCB traces under or adjacent to the XIN and XOUT pins.
 - Use assembly materials and praxis to avoid any parasitic load on the oscillator XIN and XOUT pins.
 - If conformal coating is used, ensure that it does not induce capacitive/resistive leakage between the oscillator pins.
 - Do not route the XOUT line to the JTAG header to support the serial programming adapter as shown in other documentation. This signal is no longer required for the serial programming adapter.



electrical characteristics over recommended ranges of supply voltage and operating free-air temperature (unless otherwise noted) (continued)

typical characteristics - LFXT1 oscillator in HF mode (XTS = 1)

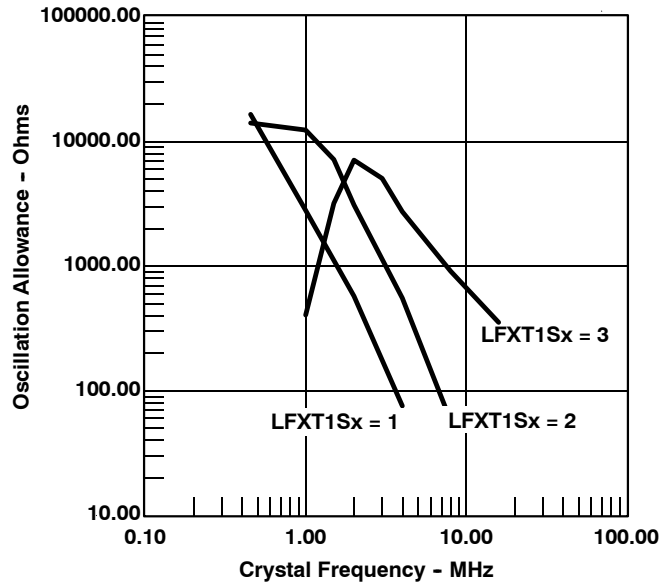

Figure 23. Oscillation Allowance vs Crystal Frequency, $C_{L,eff} = 15 \text{ pF}$, $T_A = 25^\circ\text{C}$

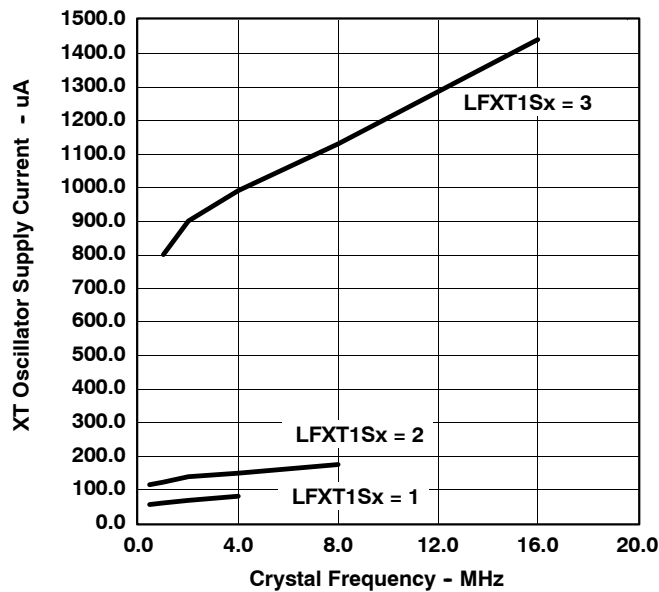

Figure 24. XT Oscillator Supply Current vs Crystal Frequency, $C_{L,eff} = 15 \text{ pF}$, $T_A = 25^\circ\text{C}$

MSP430F2618-EP MIXED SIGNAL MICROCONTROLLER

SLAS632 - DECEMBER 2008

electrical characteristics over recommended ranges of supply voltage and operating free-air temperature (unless otherwise noted) (continued)

crystal oscillator, XT2 (see Note 5)

PARAMETER		TEST CONDITIONS	V _{CC}	MIN	TYP	MAX	UNIT
f _{XT2}	XT2 oscillator crystal frequency, mode 0	XT2Sx = 0	1.8 V to 3.6 V	0.4		1	MHz
f _{XT2}	XT2 oscillator crystal frequency, mode 1	XT2Sx = 1	1.8 V to 3.6 V	1		4	MHz
f _{XT2}	XT2 oscillator crystal frequency, mode 2	XT2Sx = 2	1.8 V to 3.6 V	2		10	MHz
			2.2 V to 3.6 V	2		12	
			3 V to 3.6 V	2		16	
f _{XT2}	XT2 oscillator logic level square-wave input frequency	XT2Sx = 3	1.8 V to 3.6 V	0.4		10	MHz
			2.2 V to 3.6 V	0.4		12	
			3 V to 3.6 V	0.4		16	
OA	Oscillation allowance (see Figure 23 and Figure 24)	XT2Sx = 0, f _{XT2} = 1 MHz, C _{L,eff} = 15 pF			2700		Ω
		XT2Sx = 1, f _{XT2} = 4 MHz, C _{L,eff} = 15 pF			800		
		XT2Sx = 2, f _{XT1,HF} = 16 MHz, C _{L,eff} = 15 pF			300		
C _{L,eff}	Integrated effective load capacitance, HF mode (see Note 1)	See Note 2			1		pF
Duty cycle		Measured at P1.4/SMCLK, f _{XT2} = 10 MHz	2.2 V/3 V	40	50	60	%
		Measured at P1.4/SMCLK, f _{XT2} = 16 MHz		40	50	60	
f _{Fault}	Oscillator fault frequency, HF mode (see Note 4)	XT2Sx = 3, (see Note 3)	2.2 V/3 V	30		300	kHz

- NOTES: 1. Includes parasitic bond and package capacitance (approximately 2 pF per pin).
 Since the PCB adds additional capacitance, it is recommended to verify the correct load by measuring the ACLK frequency. For a correct setup, the effective load capacitance should always match the specification of the used crystal.
2. Requires external capacitors at both terminals. Values are specified by crystal manufacturers.
3. Measured with logic level input frequency but also applies to operation with crystals.
4. Frequencies below the MIN specification set the fault flag, frequencies above the MAX specification do not set the fault flag, and frequencies in between might set the flag.
5. To improve EMI on the LFXT1 oscillator the following guidelines should be observed.
- Keep the trace between the device and the crystal as short as possible.
 - Design a good ground plane around the oscillator pins.
 - Prevent crosstalk from other clock or data lines into oscillator pins XIN and XOUT.
 - Avoid running PCB traces under or adjacent to the XIN and XOUT pins.
 - Use assembly materials and praxis to avoid any parasitic load on the oscillator XIN and XOUT pins.
 - If conformal coating is used, ensure that it does not induce capacitive/resistive leakage between the oscillator pins.
 - Do not route the XOUT line to the JTAG header to support the serial programming adapter as shown in other documentation. This signal is no longer required for the serial programming adapter.



electrical characteristics over recommended ranges of supply voltage and operating free-air temperature (unless otherwise noted) (continued)

typical characteristics - XT2 oscillator

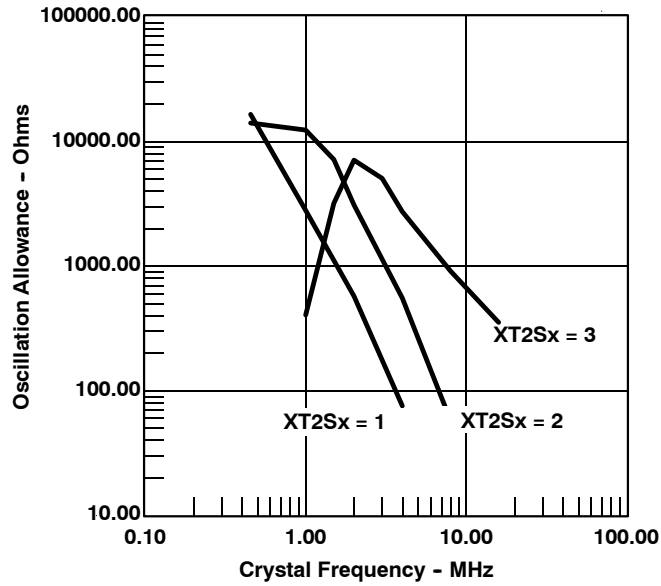

Figure 25. Oscillation Allowance vs Crystal Frequency, $C_{L,eff} = 15 \text{ pF}$, $T_A = 25^\circ\text{C}$

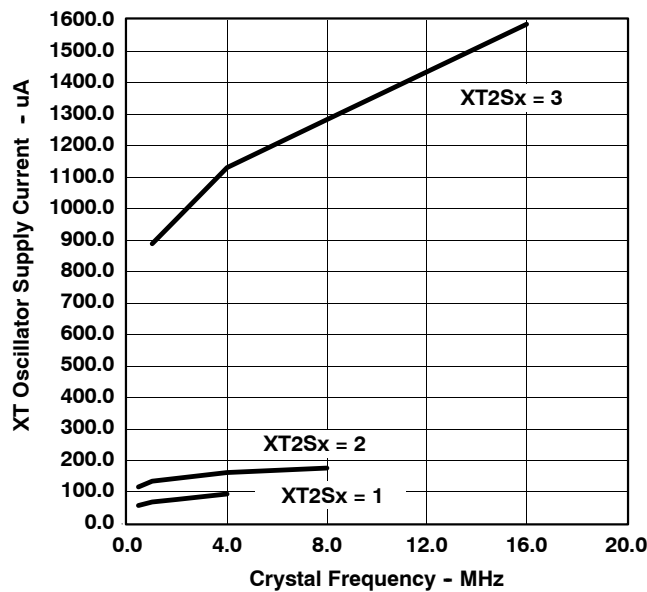

Figure 26. XT2 Oscillator Supply Current vs Crystal Frequency, $C_{L,eff} = 15 \text{ pF}$, $T_A = 25^\circ\text{C}$

MSP430F2618-EP

MIXED SIGNAL MICROCONTROLLER

SLAS632 - DECEMBER 2008

electrical characteristics over recommended ranges of supply voltage and operating free-air temperature (unless otherwise noted) (continued)

Timer_A

PARAMETER		TEST CONDITIONS	V _{CC}	MIN	MAX	UNIT
f _{TA}	Timer_A clock frequency	Internal: SMCLK, ACLK, External: TACLK, INCLK, Duty cycle = 50% ±10%	2.2 V		10	MHz
			3.3 V		16	
t _{TA,cap}	Timer_A, capture timing	TA0, TA1, TA2	2.2 V/3 V	20		ns

Timer_B

PARAMETER		TEST CONDITIONS	V _{CC}	MIN	MAX	UNIT
f _{TB}	Timer_B clock frequency	Internal: SMCLK, ACLK, External: TBCLK, Duty cycle = 50% ±10%	2.2 V		10	MHz
			3.3 V		16	
t _{TB,cap}	Timer_B, capture timing	TB0, TB1, TB2	2.2 V/3 V	20		ns



electrical characteristics over recommended ranges of supply voltage and operating free-air temperature (unless otherwise noted) (continued)

USCI (UART mode)

PARAMETER	TEST CONDITIONS	V _{CC}	MIN	TYP	MAX	UNIT
f _{USCI}	USCI input clock frequency Internal: SMCLK, ACLK External: UCLK Duty cycle = 50% ± 10%			f _{SYSTEM}		MHz
f _{BITCLK}	BITCLK clock frequency (equals baud rate in MBaud)	2.2 V / 3 V			1	MHz
t _τ	UART receive deglitch time (see Note 1)	2.2 V	50	150	600	ns
		3 V	50	100	600	ns

NOTE 1: Pulses on the UART receive input (UCxRX) shorter than the UART receive deglitch time are suppressed. To ensure that pulses are correctly recognized their width should exceed the maximum specification of the deglitch time.

USCI (SPI master mode) (see Figure 27 and Figure 28)

PARAMETER	TEST CONDITIONS	V _{CC}	MIN	MAX	UNIT
f _{USCI}	USCI input clock frequency SMCLK, ACLK Duty cycle = 50% ± 10%			f _{SYSTEM}	MHz
t _{SU,MI}	SOMI input data setup time	2.2 V	110		ns
		3 V	75		
t _{HD,MI}	SOMI input data hold time	2.2 V	0		ns
		3 V	0		
t _{VALID,MO}	SIMO output data valid time C _L = 20 pF	2.2 V		30	ns
		3 V		20	

NOTE 1: $f_{UCxCLK} = \frac{1}{2t_{LO/HI}}$ with $t_{LO/HI} \geq \max(t_{VALID,MO(USCI)} + t_{SU,SI(Slave)}, t_{SU,MI(USCI)} + t_{VALID,SO(Slave)})$.

For the slave parameters t_{SU,SI(Slave)} and t_{VALID,SO(Slave)}, see the SPI parameters of the attached slave.

USCI (SPI slave mode) (see Figure 29 and Figure 30)

PARAMETER	TEST CONDITIONS	V _{CC}	MIN	TYP	MAX	UNIT
t _{STE,LEAD}	STE lead time, STE low to clock	2.2 V/3 V		50		ns
t _{STE,LAG}	STE lag time, Last clock to STE high	2.2 V/3 V	10			ns
t _{STE,ACC}	STE access time, STE low to SOMI data out	2.2 V/3 V		50		ns
t _{STE,DIS}	STE disable time, STE high to SOMI high impedance	2.2 V/3 V		50		ns
t _{SU,SI}	SIMO input data setup time	2.2 V	20			ns
		3 V	15			
t _{HD,SI}	SIMO input data hold time	2.2 V	10			ns
		3 V	10			
t _{VALID,SO}	SOMI output data valid time C _L = 20 pF	2.2 V		75	110	ns
		3 V		50	75	

NOTE 1: $f_{UCxCLK} = \frac{1}{2t_{LO/HI}}$ with $t_{LO/HI} \geq \max(t_{VALID,MO(Master)} + t_{SU,SI(USCI)}, t_{SU,MI(Master)} + t_{VALID,SO(USCI)})$

For the master parameters t_{SU,MI(Master)} and t_{VALID,MO(Master)}, see the SPI parameters of the attached master.

MSP430F2618-EP MIXED SIGNAL MICROCONTROLLER

SLAS632 - DECEMBER 2008

electrical characteristics over recommended ranges of supply voltage and operating free-air temperature (unless otherwise noted) (continued)

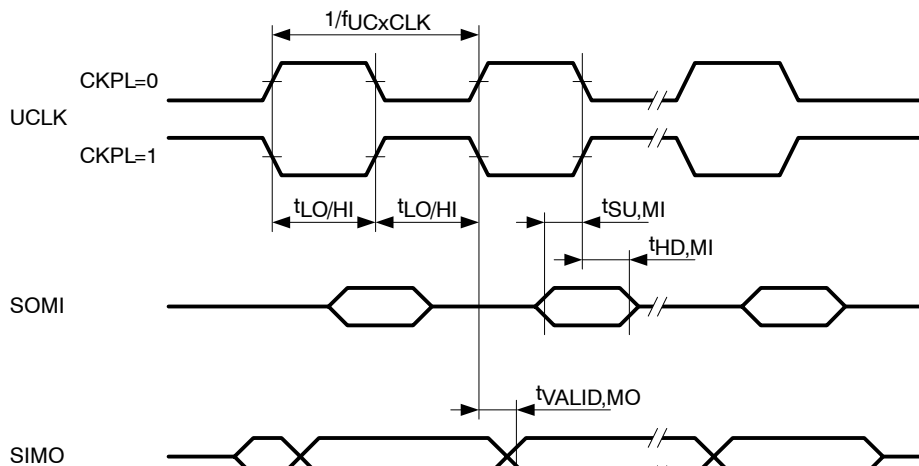

Figure 27. SPI Master Mode, CKPH = 0

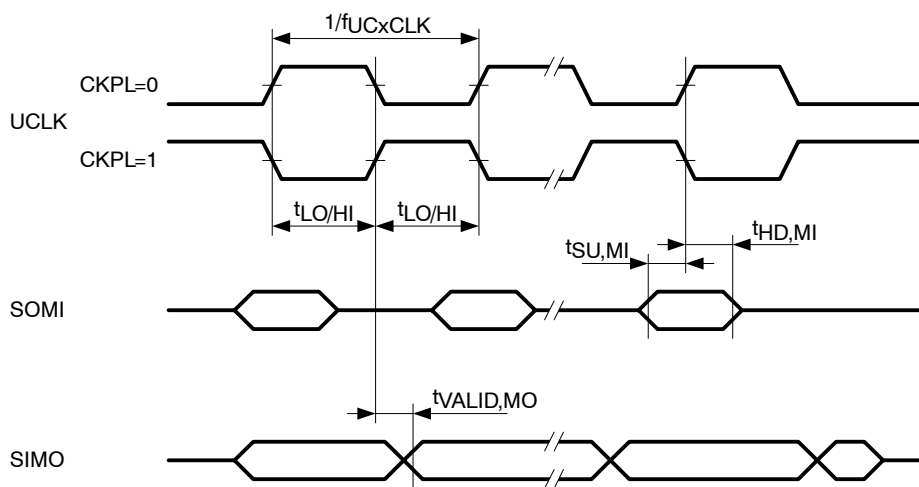

Figure 28. SPI Master Mode, CKPH = 1

electrical characteristics over recommended ranges of supply voltage and operating free-air temperature (unless otherwise noted) (continued)

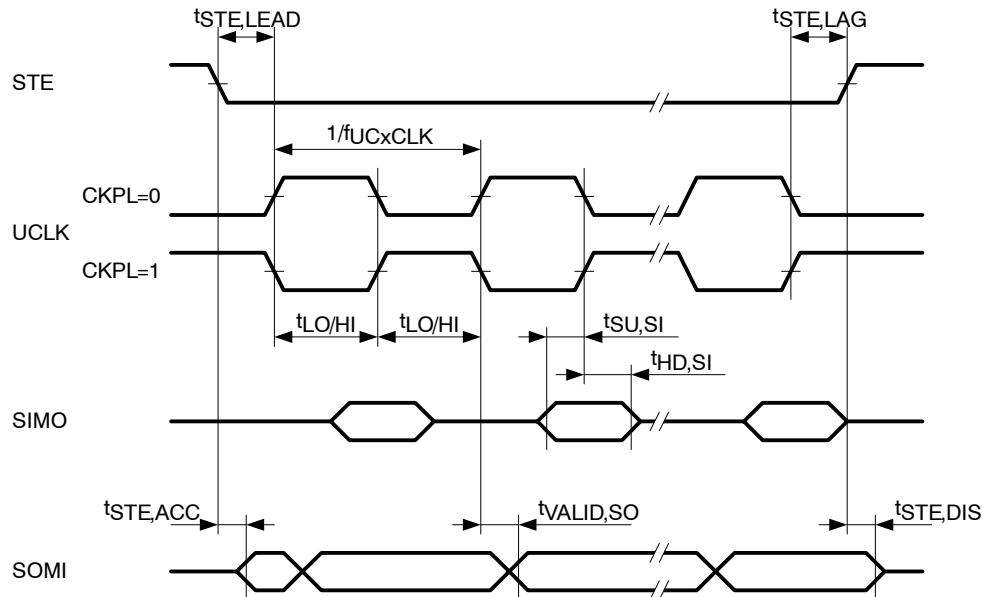

Figure 29. SPI Slave Mode, CKPH = 0

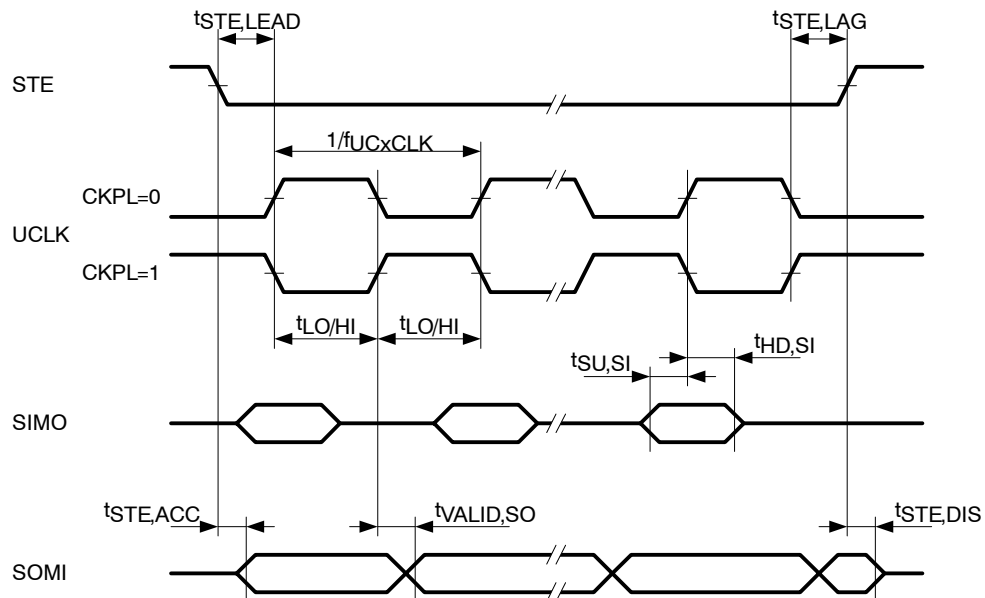

Figure 30. SPI Slave Mode, CKPH = 1

MSP430F2618-EP MIXED SIGNAL MICROCONTROLLER

SLAS632 - DECEMBER 2008

electrical characteristics over recommended ranges of supply voltage and operating free-air temperature (unless otherwise noted) (continued)

USCI (I2C mode) (see Figure 31)

PARAMETER		TEST CONDITIONS	V _{CC}	MIN	TYP	MAX	UNIT
f _{USCI}	USCI input clock frequency	Internal: SMCLK, ACLK External: UCLK Duty cycle = 50% ± 10%			f _{SYSTEM}		MHz
f _{SCL}	SCL clock frequency		2.2 V/3 V	0		400	kHz
t _{HD,STA}	Hold time (repeated) Start	f _{SCL} ≤ 100 kHz	2.2 V/3 V	4.0			μs
		f _{SCL} > 100 kHz		0.6			
t _{SU,STA}	Setup time for a repeated Start	f _{SCL} ≤ 100 kHz	2.2 V/3 V	4.7			μs
		f _{SCL} > 100 kHz		0.6			
t _{HD,DAT}	Data hold time		2.2 V/3 V	0			ns
t _{SU,DAT}	Data setup time		2.2 V/3 V	250			ns
t _{SU,STO}	Setup time for Stop		2.2 V/3 V	4.0			μs
t _{SP}	Pulse width of spikes suppressed by input filter		2.2 V	50	150	600	ns
			3 V	50	100	600	

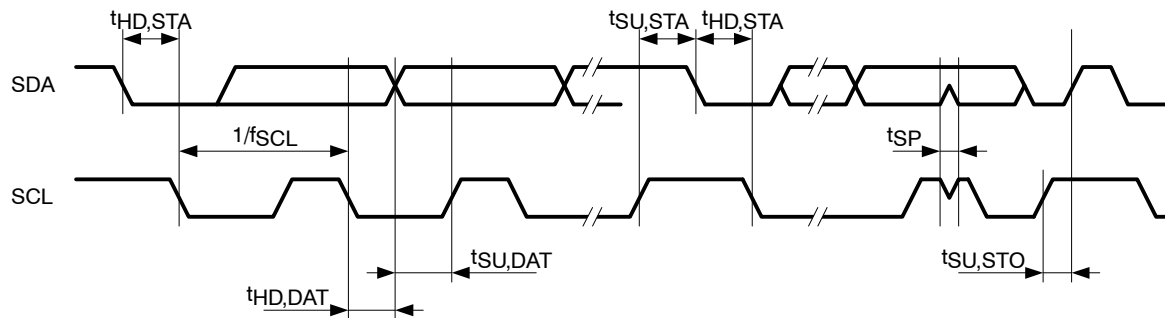

Figure 31. I2C Mode Timing

electrical characteristics over recommended ranges of supply voltage and operating free-air temperature (unless otherwise noted) (continued)

Comparator_A+ (see Note 1)

PARAMETER		TEST CONDITIONS	V _{CC}	MIN	TYP	MAX	UNIT
I _(DD)		CAON = 1, CARSEL = 0, CAREF = 0	2.2 V	25	40	μA	
			3 V	45	60		
I _(Refladder/Refdiode)		CAON = 1, CARSEL = 0, CAREF = 1/2/3, no load at P2.3/CA0/TA1 and P2.4/CA1/TA2	2.2 V	30	50	μA	
			3 V	45	71		
V _(IC)	Common-mode input voltage	CAON = 1	2.2 V/3 V	0	V _{CC} -1	V	
V _(Ref025)	$\frac{\text{Voltage at } 0.25 V_{CC} \text{ node}}{V_{CC}}$	PCA0 = 1, CARSEL = 1, CAREF = 1, no load at P2.3/CA0/TA1 and P2.4/CA1/TA2	2.2 V/3 V	0.23	0.24	0.25	
V _(Ref050)	$\frac{\text{Voltage at } 0.5 V_{CC} \text{ node}}{V_{CC}}$	PCA0 = 1, CARSEL = 1, CAREF = 2, no load at P2.3/CA0/TA1 and P2.4/CA1/TA2	2.2 V/3 V	0.47	0.48	0.5	
V _(RefVT)	See Figure 35 and Figure 36	PCA0 = 1, CARSEL = 1, CAREF = 3, no load at P2.3/CA0/TA1 and P2.4/CA1/TA2, T _A = 85°C	2.2 V	390	480	540	mV
			3 V	400	490	550	
V _(offset)	Offset voltage	See Note 2	2.2 V/3 V	-30		30	mV
V _(hys)	Input hysteresis	CAON=1	2.2 V/3 V	0	0.7	1.4	mV
t _(response)	Response time, low-to-high and high-to-low (see Note 3)	T _A = 25°C, Overdrive 10 mV, Without filter: CAF = 0	2.2 V	80	165	300	ns
			3 V	70	120	240	
		T _A = 25°C, Overdrive 10 mV, With filter: CAF = 1	2.2 V	1.4	1.9	2.8	μs
			3 V	0.9	1.5	2.2	

- NOTES: 1. The leakage current for the Comparator_A+ terminals is identical to I_{lkg(Px.x)} specification.
 2. The input offset voltage can be cancelled by using the CAEX bit to invert the Comparator_A+ inputs on successive measurements. The two successive measurements are then summed together.
 3. The response time is measured at P2.2/CAOUT/TA0/CA4 with an input voltage step, with Comparator_A+ already enabled (CAON = 1). If CAON is set at the same time, a settling time of up to 300 ns is added to the response time.

MSP430F2618-EP MIXED SIGNAL MICROCONTROLLER

SLAS632 - DECEMBER 2008

electrical characteristics over recommended ranges of supply voltage and operating free-air temperature (unless otherwise noted) (continued)

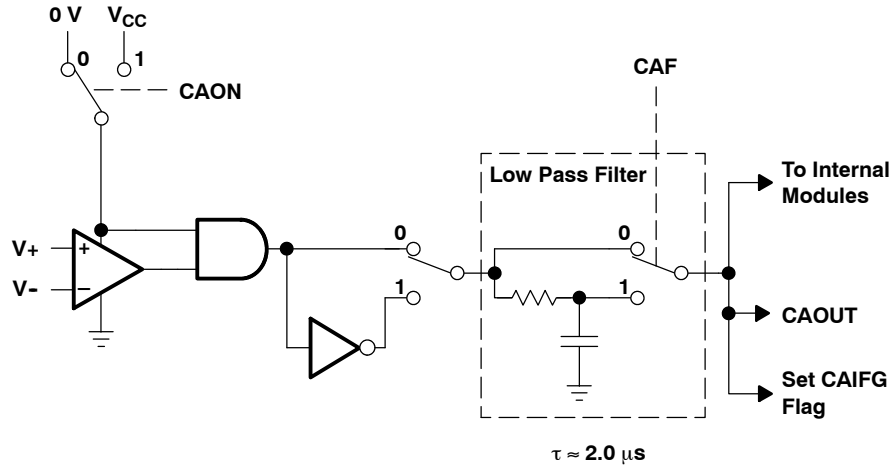

Figure 32. Block Diagram of Comparator_A Module

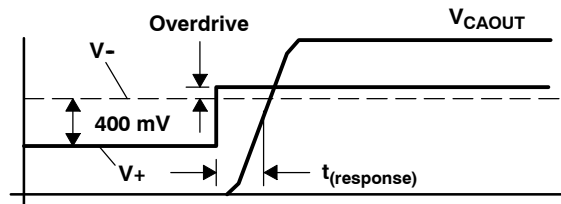

Figure 33. Overdrive Definition

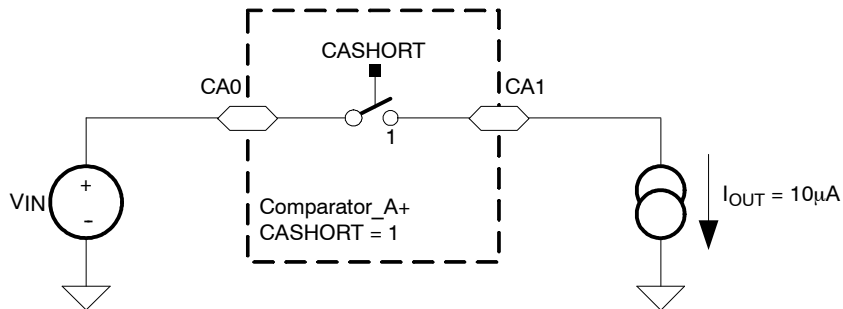

Figure 34. Comparator_A+ Short Resistance Test Condition

electrical characteristics over recommended ranges of supply voltage and operating free-air temperature (unless otherwise noted) (continued)

typical characteristics - Comparator A+

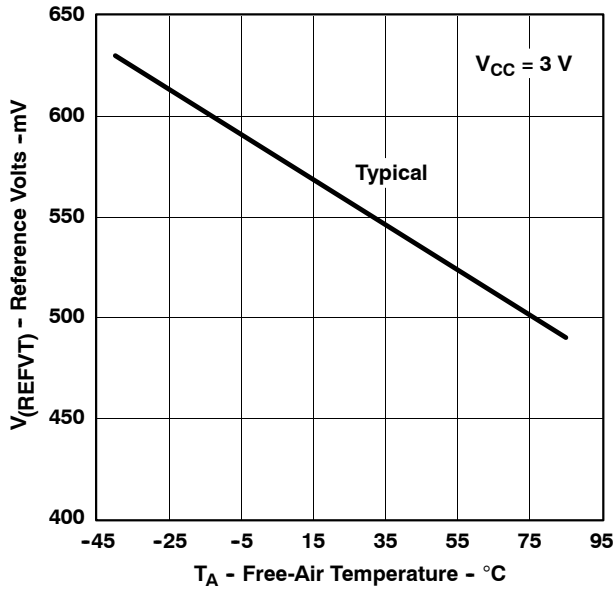

Figure 35. V_(REFVT) vs Temperature, V_{CC} = 3 V

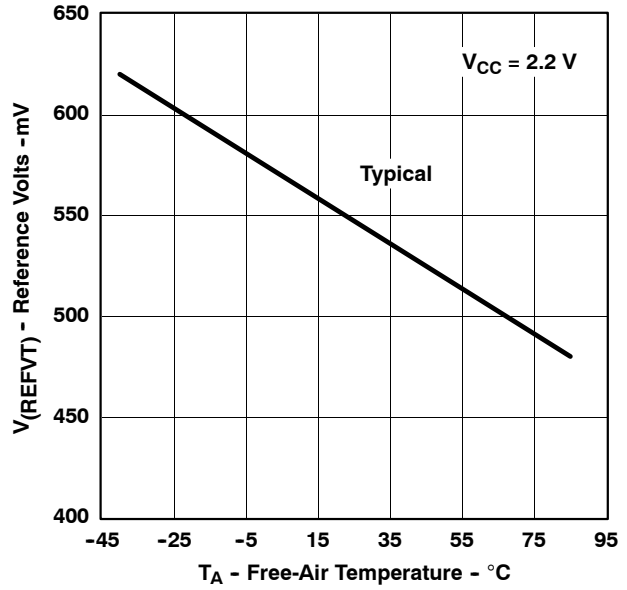

Figure 36. V_(REFVT) vs Temperature, V_{CC} = 2.2 V

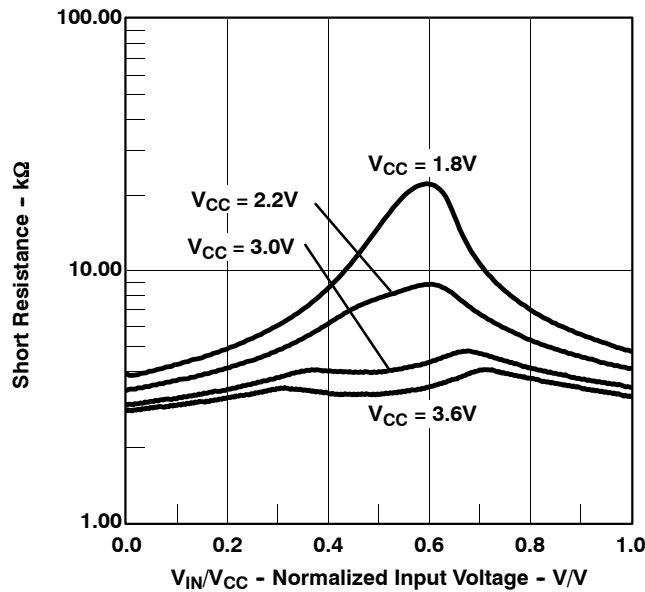

Figure 37. Short Resistance vs V_{IN}/V_{CC}

MSP430F2618-EP MIXED SIGNAL MICROCONTROLLER

SLAS632 – DECEMBER 2008

electrical characteristics over recommended ranges of supply voltage and operating free-air temperature (unless otherwise noted) (continued)

12-bit ADC power supply and input range conditions (see Note 1)

PARAMETER		TEST CONDITIONS	V _{CC}	MIN	TYP	MAX	UNIT
V _{AVCC}	Analog supply voltage	AV _{CC} and DV _{CC} are connected together, AV _{SS} and DV _{SS} are connected together, V _(AVSS) = V _(DVSS) = 0 V		2.2		3.6	V
V _(P6.x/Ax)	Analog input voltage (see Note 2)	All P6.0/A0 to P6.7/A7 terminals. Analog inputs selected in ADC12MCTLx register and P6Sel.x = 1, 0 ≤ x ≤ 7, V _(AVSS) ≤ V _{P6.x/Ax} ≤ V _(AVCC)		0		V _{AVCC}	V
I _{ADC12}	Operating supply current into AV _{CC} terminal (see Note 3)	f _{ADC12CLK} = 5 MHz, ADC12ON = 1, REFON = 0, SHT0 = 0, SHT1 = 0, ADC12DIV = 0	2.2 V		0.65	0.8	mA
			3 V		0.8	1.0	
I _{REF+}	Operating supply current into AV _{CC} terminal (see Note 4)	f _{ADC12CLK} = 5 MHz, ADC12ON = 0, REFON = 1, REF2_5V = 1	3 V		0.5	0.7	mA
			2.2 V		0.5	0.7	
		f _{ADC12CLK} = 5 MHz, ADC12ON = 0, REFON = 1, REF2_5V = 0	2.2 V		0.5	0.7	
			3 V		0.5	0.7	
C _i †	Input capacitance	Only one terminal can be selected at one time, P6.x/Ax	2.2 V			40	pF
R _i †	Input MUX ON resistance	0 V ≤ V _{Ax} ≤ V _{AVCC}	3 V			2000	Ω

† Limits verified by design

- NOTES: 1. The leakage current is defined in the leakage current table with P6.x/Ax parameter.
 2. The analog input voltage range must be within the selected reference voltage range V_{R+} to V_{R-} for valid conversion results.
 3. The internal reference supply current is not included in current consumption parameter I_{ADC12}.
 4. The internal reference current is supplied via terminal AV_{CC}. Consumption is independent of the ADC12ON control bit, unless a conversion is active. The REFON bit enables to settle the built-in reference before starting an A/D conversion.

12-bit ADC external reference (see Note 1)

PARAMETER		TEST CONDITIONS	V _{CC}	MIN	MAX	UNIT
V _{eREF+}	Positive external reference voltage input	V _{eREF+} > V _{REF-} /V _{eREF-} (see Note 2)		1.4	V _{AVCC}	V
V _{REF-} /V _{eREF-}	Negative external reference voltage input	V _{eREF+} > V _{REF-} /V _{eREF-} (see Note 3)		0	1.2	V
(V _{eREF+} - V _{REF-})/V _{eREF-}	Differential external reference voltage input	V _{eREF+} > V _{REF-} /V _{eREF-} (see Note 4)		1.4	V _{AVCC}	V
I _{VeREF+}	Static input current	0V ≤ V _{eREF+} ≤ V _{AVCC}	2.2 V/3 V		±1	μA
I _{VREF-/VeREF-}	Static input current	0V ≤ V _{eREF-} ≤ V _{AVCC}	2.2 V/3 V		±1	μA

- NOTES: 1. The external reference is used during conversion to charge and discharge the capacitance array. The input capacitance, C_i, is also the dynamic load for an external reference during conversion. The dynamic impedance of the reference supply should follow the recommendations on analog-source impedance to allow the charge to settle for 12-bit accuracy.
 2. The accuracy limits the minimum positive external reference voltage. Lower reference voltage levels may be applied with reduced accuracy requirements.
 3. The accuracy limits the maximum negative external reference voltage. Higher reference voltage levels may be applied with reduced accuracy requirements.
 4. The accuracy limits minimum external differential reference voltage. Lower differential reference voltage levels may be applied with reduced accuracy requirements.



electrical characteristics over recommended ranges of supply voltage and operating free-air temperature (unless otherwise noted) (continued)

12-bit ADC built-in reference

PARAMETER	TEST CONDITIONS	V _{CC}	TA	MIN	TYP	MAX	UNIT
V _{REF+} Positive built-in reference voltage output	REF2_5V = 1 (2.5 V) I _{VREF+} max ≤ I _{VREF+} ≤ I _{VREF+} min	3 V	-40°C to 85°C	2.4	2.5	2.6	V
			105°C	2.37	2.5	2.64	
	REF2_5V = 0 (1.5 V) I _{VREF+} max ≤ I _{VREF+} ≤ I _{VREF+} min	2.2 V/3 V 2.2 V/3 V	-40°C to 85°C	1.44	1.5	1.56	
			105°C	1.42	1.5	1.57	
AV _{CC(min)} AV _{CC} minimum voltage, positive built-in reference active	REF2_5V = 0, I _{VREF+} max ≤ I _{VREF+} ≤ I _{VREF+} min			2.2			V
	REF2_5V = 1, -0.5mA ≤ I _{VREF+} ≤ I _{VREF+} min		2.8				
	REF2_5V = 1, -1mA ≤ I _{VREF+} ≤ I _{VREF+} min		2.9				
I _{VREF+} Load current out of V _{REF+} terminal		2.2 V		0.01		-0.5	mA
		3 V		0.01		-1	
I _{L(VREF+)} † Load-current regulation, V _{REF+} terminal	I _{VREF+} = 500 μA +/- 100 μA Analog input voltage ~0.75 V, REF2_5V = 0	2.2 V				±2	LSB
		3 V				±2	
	I _{VREF+} = 500 μA ± 100 μA Analog input voltage ~1.25 V, REF2_5V = 1	3 V				±2	
I _{DL(VREF+)} ‡ Load current regulation V _{REF+} terminal	I _{VREF+} = 100 μA → 900 μA, C _{VREF+} = 5 μF, at ~0.5 V _{REF+} , Error of conversion result ≤ 1 LSB	3 V				20	ns
C _{VREF+} Capacitance at pin V _{REF+} (see Note 1)	REFON = 1, 0 mA ≤ I _{VREF+} ≤ I _{VREF+} max	2.2 V/3 V		5	10		μF
T _{REF+} † Temperature coefficient of built-in reference	I _{VREF+} is a constant in the range of 0 mA ≤ I _{VREF+} ≤ 1 mA	2.2 V/3 V				±100	ppm/°C
t _{REFON} † Settle time of internal reference voltage (see Figure 38 and Note 2)	I _{VREF+} = 0.5 mA, C _{VREF+} = 10 μF, V _{REF+} = 1.5 V, V _{AVCC} = 2.2 V					17	ms

† Limits characterized

‡ Limits verified by design

- NOTES: 1. The internal buffer operational amplifier and the accuracy specifications require an external capacitor. All INL and DNL tests use two capacitors between pins V_{REF+} and AV_{SS} and V_{REF-}/V_{eREF-} and AV_{SS}: 10 μF tantalum and 100 nF ceramic.
2. The condition is that the error in a conversion started after t_{REFON} is less than ±0.5 LSB. The settling time depends on the external capacitive load.

MSP430F2618-EP MIXED SIGNAL MICROCONTROLLER

SLAS632 - DECEMBER 2008

electrical characteristics over recommended ranges of supply voltage and operating free-air temperature (unless otherwise noted) (continued)

typical characteristics - ADC12

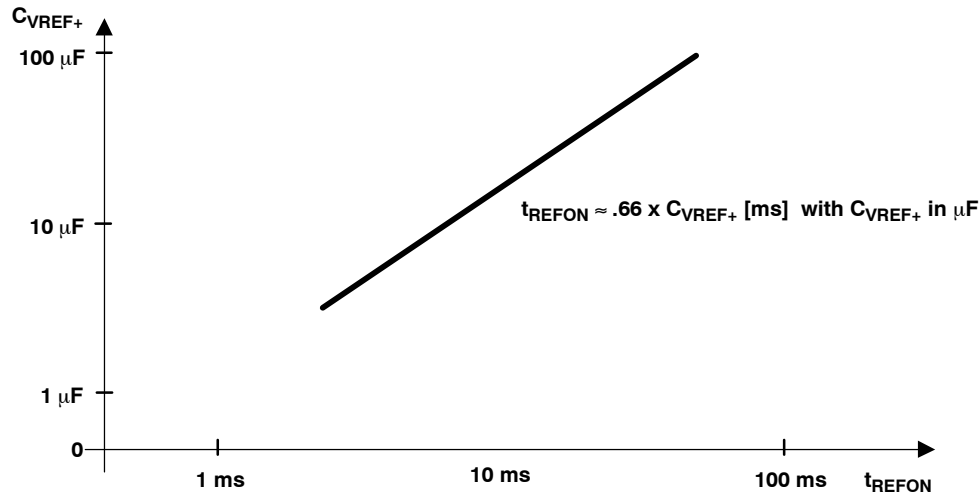

Figure 38. Typical Settling Time of Internal Reference t_{REFON} vs External Capacitor on V_{REF+}

electrical characteristics over recommended ranges of supply voltage and operating free-air temperature (unless otherwise noted) (continued)

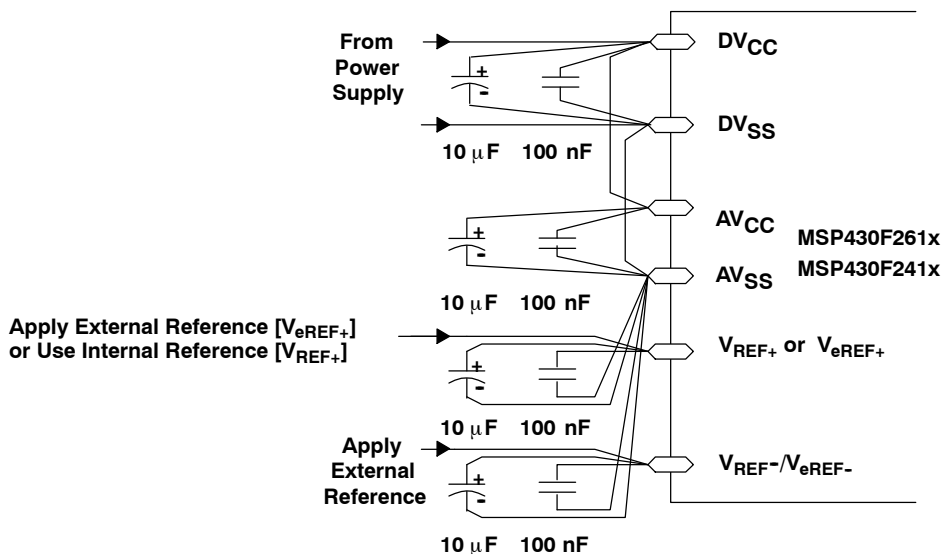

Figure 39. Supply Voltage and Reference Voltage Design V_{REF-}/V_{eREF-} External Supply

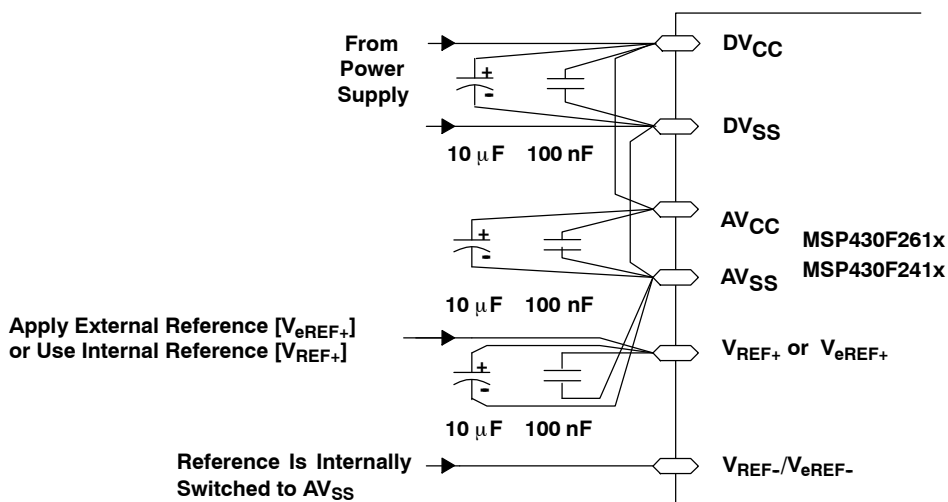

Figure 40. Supply Voltage and Reference Voltage Design V_{REF-}/V_{eREF-} = AV_{SS}, Internally Connected

MSP430F2618-EP MIXED SIGNAL MICROCONTROLLER

SLAS632 - DECEMBER 2008

electrical characteristics over recommended ranges of supply voltage and operating free-air temperature (unless otherwise noted) (continued)

12-bit ADC timing parameters

PARAMETER	TEST CONDITIONS	V _{CC}	MIN	TYP	MAX	UNIT
f _{ADC12CLK}	For specified performance of ADC12 linearity parameters	2.2V/3 V	0.45	5	6.3	MHz
f _{ADC12OSC}	Internal ADC12 oscillator ADC12DIV = 0, f _{ADC12CLK} = f _{ADC12OSC}	2.2 V/ 3 V	3.7	5	6.3	MHz
t _{CONVERT}	Conversion time C _{VREF+} ≥ 5 μF, Internal oscillator, f _{ADC12OSC} = 3.7 MHz to 6.3 MHz External f _{ADC12CLK} from ACLK, MCLK or SMCLK, ADC12SSEL ≠ 0	2.2 V/ 3 V	2.06		3.51	μs
					13 × ADC12DIV × 1/f _{ADC12CLK}	
t _{ADC12ON} [†]	Turn-on settling time of the ADC See Note 1				100	ns
t _{Sample} [‡]	Sampling time R _S = 400 Ω, R _I = 1000 Ω, C _I = 30 pF, τ = [R _S + R _I] × C _I (see Note 2)	3 V 2.2 V	1220			ns

[†] Limits characterized

[‡] Limits verified by design

NOTES: 1. The condition is that the error in a conversion started after t_{ADC12ON} is less than ±0.5 LSB. The reference and input signal are already settled.

2. Approximately ten Tau (τ) are needed to get an error of less than ±0.5 LSB:

$$t_{\text{Sample}} = \ln(2^{n+1}) \times (R_S + R_I) \times C_I + 800 \text{ ns where } n = \text{ADC resolution} = 12, R_S = \text{external source resistance.}$$

12-bit ADC linearity parameters

PARAMETER	TEST CONDITIONS	V _{CC}	MIN	TYP	MAX	UNIT
E _I	Integral linearity error 1.4 V ≤ (V _{eREF+} - V _{REF-/V_{eREF-}}) min ≤ 1.6 V 1.6 V < (V _{eREF+} - V _{REF-/V_{eREF-}}) min ≤ V _{AVCC}	2.2 V/3 V			±2 ±1.7	LSB
E _D	Differential linearity error (V _{eREF+} - V _{REF-/V_{eREF-}}) _{min} ≤ (V _{eREF+} - V _{REF-/V_{eREF-}}), C _{VREF+} = 10 μF (tantalum) and 100 nF (ceramic)	2.2 V/3 V			±1	LSB
E _O	Offset error (V _{eREF+} - V _{REF-/V_{eREF-}}) _{min} ≤ (V _{eREF+} - V _{REF-/V_{eREF-}}), Internal impedance of source R _S < 100 Ω, C _{VREF+} = 10 μF (tantalum) and 100 nF (ceramic)	2.2 V/3 V		±2	±4	LSB
E _G	Gain error (V _{eREF+} - V _{REF-/V_{eREF-}}) _{min} ≤ (V _{eREF+} - V _{REF-/V_{eREF-}}), C _{VREF+} = 10 μF (tantalum) and 100 nF (ceramic)	2.2 V/3 V		±1.1	±2	LSB
E _T	Total unadjusted error (V _{eREF+} - V _{REF-/V_{eREF-}}) _{min} ≤ (V _{eREF+} - V _{REF-/V_{eREF-}}), C _{VREF+} = 10 μF (tantalum) and 100 nF (ceramic)	2.2 V/3 V		±2	±5	LSB



electrical characteristics over recommended operating free-air temperature (unless otherwise noted) (continued)

12-bit ADC temperature sensor and built-in V_{MID}

PARAMETER		TEST CONDITIONS	V_{CC}	MIN	TYP	MAX	UNIT
I_{SENSOR}	Operating supply current into AV_{CC} terminal (see Note 1)	REFON = 0, INCH = 0Ah, ADC12ON = 1, $T_A = 25^\circ C$	2.2 V		40	120	μA
			3 V		60	160	
V_{SENSOR}^\dagger	See Note 2	ADC12ON = 1, INCH = 0Ah, $T_A = 0^\circ C$	2.2 V		986		mV
			3 V		986		
TC_{SENSOR}^\dagger		ADC12ON = 1, INCH = 0Ah	2.2 V		3.55		mV/ $^\circ C$
			3 V		3.55		
$t_{SENSOR(sample)}^\dagger$	Sample time required if channel 10 is selected (see Note 3)	ADC12ON = 1, INCH = 0Ah, Error of conversion result ≤ 1 LSB	2.2 V	30			μs
			3 V	30			
I_{VMID}	Current into divider at channel 11 (see Note 4)	ADC12ON = 1, INCH = 0Bh	2.2 V			NA	μA
			3 V			NA	
V_{MID}	AV_{CC} divider at channel 11	ADC12ON = 1, INCH = 0Bh, V_{MID} is $\sim 0.5 \times V_{AVCC}$	2.2 V	1.1		1.1 ± 0.04	V
			3 V	1.5		1.50 ± 0.04	
$t_{VMID(sample)}$	Sample time required if channel 11 is selected (see Note 5)	ADC12ON = 1, INCH = 0Bh, Error of conversion result ≤ 1 LSB	2.2 V	1400			ns
			3 V	1220			

† Limits characterized

- NOTES:
1. The sensor current I_{SENSOR} is consumed if (ADC12ON = 1 and REFON = 1) or if (ADC12ON = 1, INCH = 0Ah and sample signal is high). When REFON = 1, I_{SENSOR} is already included in I_{REF+} .
 2. The temperature sensor offset can be as much as $\pm 20^\circ C$. A single-point calibration is recommended to minimize the offset error of the built-in temperature sensor.
 3. The typical equivalent impedance of the sensor is 51 k Ω . The sample time required includes the sensor-on time $t_{SENSOR(on)}$.
 4. No additional current is needed. The V_{MID} is used during sampling.
 5. The on time $t_{VMID(on)}$ is included in the sampling time $t_{VMID(sample)}$; no additional on time is needed.

MSP430F2618-EP MIXED SIGNAL MICROCONTROLLER

SLAS632 - DECEMBER 2008

electrical characteristics over recommended ranges of supply voltage and operating free-air temperature (unless otherwise noted) (continued)

12-bit DAC supply specifications

PARAMETER	TEST CONDITIONS	V _{CC}	T _A	MIN	TYP	MAX	UNIT
AV _{CC} Analog supply voltage	AV _{CC} = DV _{CC} , AV _{SS} = DV _{SS} = 0 V			2.20		3.60	V
I _{DD} Supply current, single DAC channel (see Notes 1 and 2)	DAC12AMP _x = 2, DAC12IR = 0, DAC12_xDAT = 0x0800	2.2V/3V	-40°C to 85°C		50	110	μA
			105°C		69	150	
	DAC12AMP _x = 2, DAC12IR = 1, DAC12_xDAT = x00800, V _{eREF+} = V _{REF+} = AV _{CC}	2.2V/3V			50	130	
	DAC12AMP _x = 5, DAC12IR = 1, DAC12_xDAT = 0x0800, V _{eREF+} = V _{REF+} = AV _{CC}	2.2V/3V			200	440	
	DAC12AMP _x = 7, DAC12IR = 1, DAC12_xDAT = 0x0800, V _{eREF+} = V _{REF+} = AV _{CC}	2.2V/3V			700	1500	
PSRR Power-supply rejection ratio (see Notes 3 and 4)	DAC12_xDAT = 800h, V _{REF} = 1.5 V, ΔAV _{CC} = 100mV	2.2V			70		dB
	DAC12_xDAT = 800h, V _{REF} = 1.5 V or 2.5 V, ΔAV _{CC} = 100mV	3V					

- NOTES: 1. No load at the output pin, DAC12_0 or DAC12_1, assuming that the control bits for the shared pins are set properly.
 2. Current into reference terminals not included. If DAC12IR = 1 current flows through the input divider; see Reference Input specifications.
 3. PSRR = 20 × log{ΔAV_{CC}/ΔV_{DAC12_xOUT}}
 4. V_{REF} is applied externally. The internal reference is not used.



electrical characteristics over recommended operating free-air temperature (unless otherwise noted) (continued)

12-bit DAC linearity specifications (see Figure 41)

PARAMETER		TEST CONDITIONS	V _{CC}	MIN	TYP	MAX	UNIT
Resolution		12-bit monotonic		12			bits
INL	Integral nonlinearity (see Note 1)	V _{REF} = 1.5 V DAC12AMP _x = 7, DAC12IR = 1	2.2 V	±2.0		±8.0	LSB
		V _{REF} = 2.5 V DAC12AMP _x = 7, DAC12IR = 1	3 V				
DNL	Differential nonlinearity (see Note 1)	V _{REF} = 1.5 V DAC12AMP _x = 7, DAC12IR = 1	2.2 V	±0.4		±1.0	LSB
		V _{REF} = 2.5 V DAC12AMP _x = 7, DAC12IR = 1	3 V				
E _O	Offset voltage without calibration (see Notes 1 and 2)	V _{REF} = 1.5 V DAC12AMP _x = 7, DAC12IR = 1	2.2 V			±21	mV
		V _{REF} = 2.5 V DAC12AMP _x = 7, DAC12IR = 1	3 V				
	Offset voltage with calibration (see Notes 1 and 2)	V _{REF} = 1.5 V DAC12AMP _x = 7, DAC12IR = 1	2.2 V				
		V _{REF} = 2.5 V DAC12AMP _x = 7, DAC12IR = 1	3 V				
d _{E(O)/dT}	Offset error temperature coefficient (see Note 1)		2.2 V/3 V	30		μV/C	
E _G	Gain error (see Note 1)	V _{REF} = 1.5 V	2.2 V			±3.50	% FSR
		V _{REF} = 2.5 V	3 V				
d _{E(G)/dT}	Gain temperature coefficient (see Note 1)		2.2 V/3 V	10		ppm of FSR/°C	
t _{Offset_Cal}	Time for offset calibration (see Note 3)	DAC12AMP _x = 2	2.2 V/3 V			100	ms
		DAC12AMP _x = 3, 5				32	
		DAC12AMP _x = 4, 6, 7				6	

- NOTES: 1. Parameters calculated from the best-fit curve from 0x0A to 0xFFF. The best-fit curve method is used to deliver coefficients “a” and “b” of the first-order equation: $y = a + b \times x$. $V_{DAC12_xOUT} = E_O + (1 + E_G) \times (V_{eREF+}/4095) \times DAC12_xDAT$, DAC12IR = 1.
 2. The offset calibration works on the output operational amplifier. Offset calibration is triggered setting bit DAC12CALON.
 3. The offset calibration can be done if DAC12AMP_x = {2, 3, 4, 5, 6, 7}. The output operational amplifier is switched off with DAC12AMP_x = {0, 1}. The DAC12 module should be configured prior to initiating calibration. Port activity during calibration may affect accuracy and is not recommended.

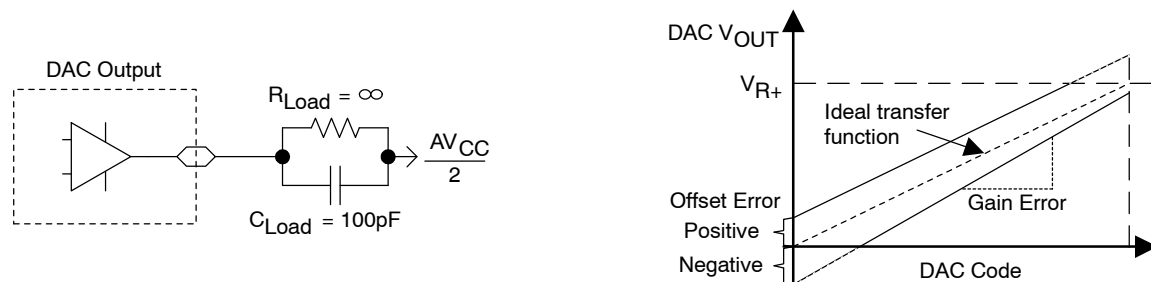

Figure 41. Linearity Test Load Conditions and Gain/Offset Definition

MSP430F2618-EP MIXED SIGNAL MICROCONTROLLER

SLAS632 - DECEMBER 2008

electrical characteristics over recommended operating free-air temperature (unless otherwise noted) (continued)

typical characteristics - 12-bit DAC, linearity specifications

TYPICAL INL ERROR
vs
DIGITAL INPUT DATA

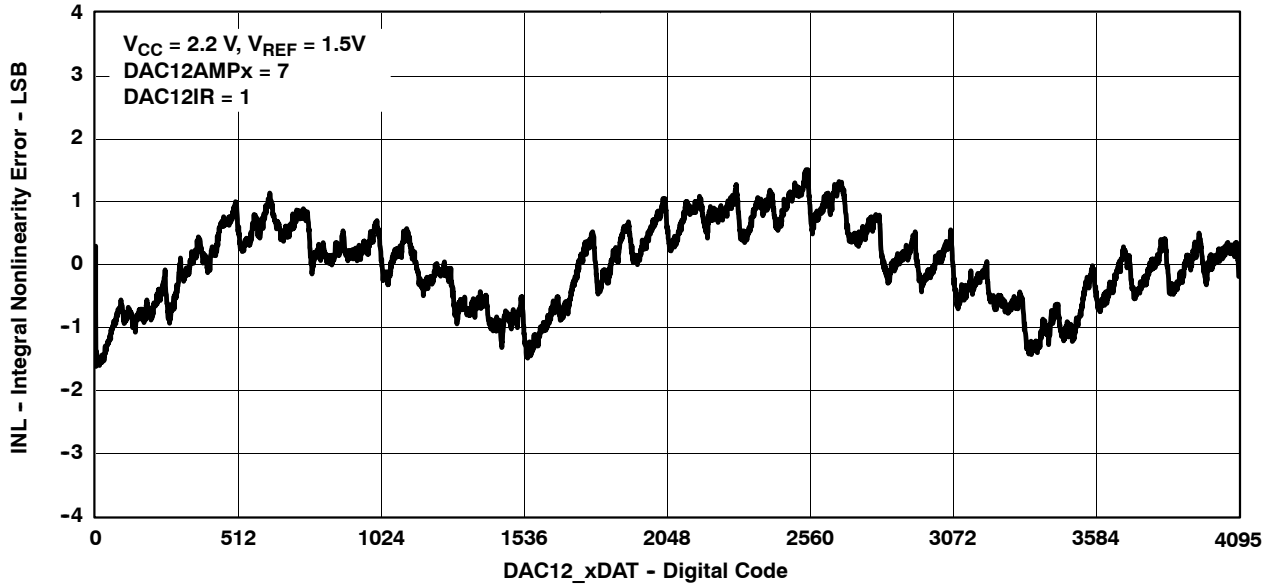

TYPICAL DNL ERROR
vs
DIGITAL INPUT DATA

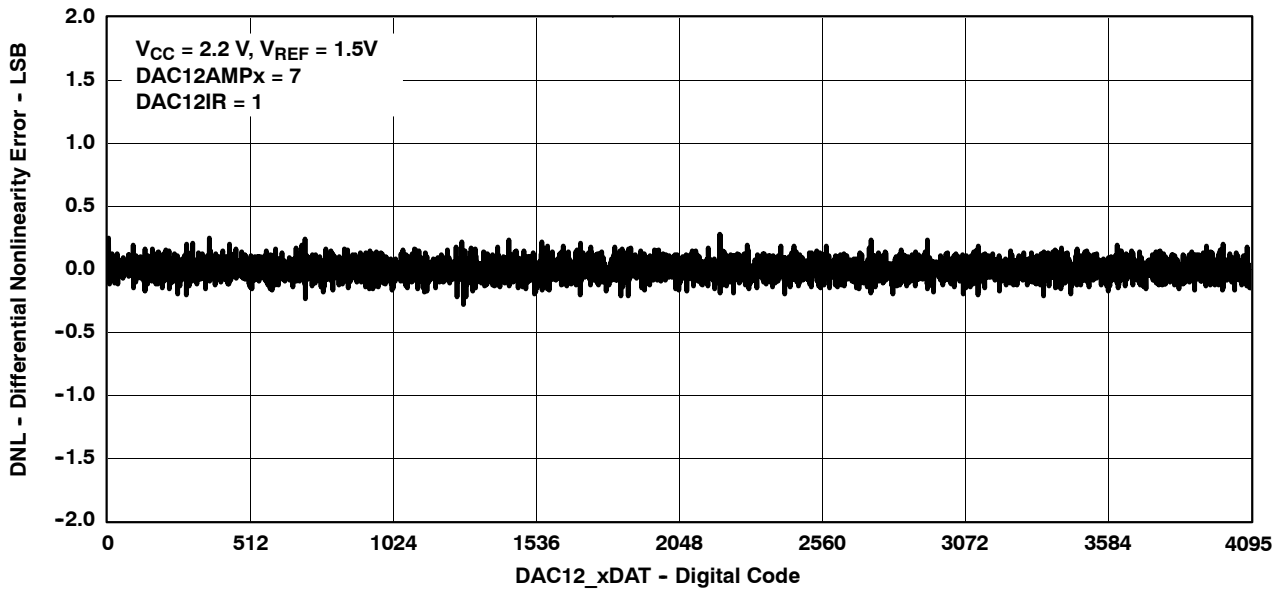

electrical characteristics over recommended operating free-air temperature (unless otherwise noted) (continued)

12-bit DAC output specifications

PARAMETER	TEST CONDITIONS	V _{CC}	MIN	TYP	MAX	UNIT
V _O Output voltage range (see Note 1 and Figure 44)	No Load, V _{REF+} = AV _{CC} , DAC12_xDAT = 0h, DAC12IR = 1, DAC12AMPx = 7	2.2 V/3 V	0		0.005	V
	No Load, V _{REF+} = AV _{CC} , DAC12_xDAT = 0FFFh, DAC12IR = 1, DAC12AMPx = 7		AV _{CC} -0.05		AV _{CC}	
	R _{Load} = 3 kΩ, V _{REF+} = AV _{CC} , DAC12_xDAT = 0h, DAC12IR = 1, DAC12AMPx = 7		0		0.1	
	R _{Load} = 3 kΩ, V _{REF+} = AV _{CC} , DAC12_xDAT = 0FFFh, DAC12IR = 1, DAC12AMPx = 7		AV _{CC} -0.13		AV _{CC}	
C _{L(DAC12)} Max DAC12 load capacitance		2.2 V/3 V			100	pF
I _{L(DAC12)} Max DAC12 load current		2.2V	-0.5		+0.5	mA
		3V	-1.0		+1.0	
R _{O/P(DAC12)} Output resistance (see Figure 44)	R _{Load} = 3 kΩ, V _{O/P(DAC12)} = 0 V, DAC12AMPx = 7, DAC12_xDAT = 0h	2.2 V/3 V		150	250	Ω
	R _{Load} = 3 kΩ, V _{O/P(DAC12)} = AV _{CC} , DAC12AMPx = 7, DAC12_xDAT = 0FFFh			150	250	
	R _{Load} = 3 kΩ, 0.3 V < V _{O/P(DAC12)} ≤ AV _{CC} - 0.3 V, DAC12AMPx = 7			1	4	

NOTE 1: Data is valid after the offset calibration of the output amplifier.

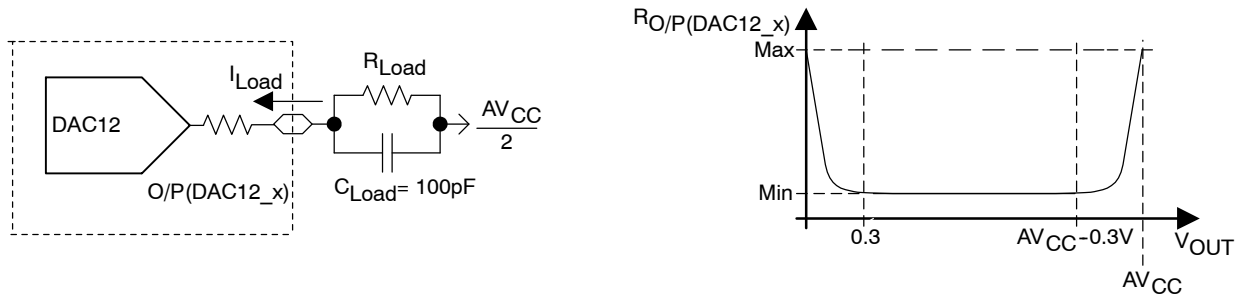

Figure 44. DAC12_x Output Resistance Tests

MSP430F2618-EP MIXED SIGNAL MICROCONTROLLER

SLAS632 - DECEMBER 2008

electrical characteristics over recommended operating free-air temperature (unless otherwise noted) (continued)

12-bit DAC reference input specifications

PARAMETER	TEST CONDITIONS	V _{CC}	MIN	TYP	MAX	UNIT
V _{REF+} Reference input voltage range	DAC12IR = 0, (see Notes 1 and 2)	2.2 V/3 V	AV _{CC} /3		AV _{CC} +0.2	V
	DAC12IR = 1, (see Notes 3 and 4)		AV _{CC}		AV _{CC} +0.2	
R _{i(VREF+)} , R _{i(VeREF+)} Reference input resistance	DAC12_0 IR = DAC12_1 IR = 0	2.2 V/3 V	20			MΩ
	DAC12_0 IR = 1, DAC12_1 IR = 0		40	48	56	kΩ
	DAC12_0 IR = 0, DAC12_1 IR = 1					
	DAC12_0 IR = DAC12_1 IR = 1 DAC12_0 SREFx = DAC12_1 SREFx (see Note 5)		20	24	28	

- NOTES: 1. For a full-scale output, the reference input voltage can be as high as 1/3 of the maximum output voltage swing (AV_{CC}).
 2. The maximum voltage applied at reference input voltage terminal V_{REF+} = [AV_{CC} - V_{E(O)}] / [3*(1 + E_G)].
 3. For a full-scale output, the reference input voltage can be as high as the maximum output voltage swing (AV_{CC}).
 4. The maximum voltage applied at reference input voltage terminal V_{REF+} = [AV_{CC} - V_{E(O)}] / (1 + E_G).
 5. When DAC12IR = 1 and DAC12SREFx = 0 or 1 for both channels, the reference input resistive dividers for each DAC are in parallel reducing the reference input resistance.

12-bit DAC dynamic specifications, V_{ref} = V_{CC}, DAC12IR = 1 (see Figure 45 and Figure 46)

PARAMETER	TEST CONDITIONS	V _{CC}	MIN	TYP	MAX	UNIT
t _{ON} DAC12 on-time	DAC12_xDAT = 800h, Error _{V(O)} < ±0.5 LSB (see Note 1 and Figure 45)	2.2 V/3 V		60	120	μs
			DAC12AMPx = 0 → {2, 3, 4}			
			DAC12AMPx = 0 → {5, 6}	15	30	
	DAC12AMPx = 0 → 7		6	12		
t _{S(FS)} Settling time, full scale	DAC12_xDAT = 80h → F7Fh → 80h	2.2 V/3 V		100	200	μs
			DAC12AMPx = 2			
			DAC12AMPx = 3, 5	40	80	
	DAC12AMPx = 4, 6, 7		15	30		
t _{S(C-C)} Settling time, code to code	DAC12_xDAT = 3F8h → 408h → 3F8h BF8h → C08h → BF8h	2.2 V/3 V		5		μs
			DAC12AMPx = 2			
			DAC12AMPx = 3, 5	2		
	DAC12AMPx = 4, 6, 7		1			
SR Slew rate	DAC12_xDAT = 80h → F7Fh → 80h	2.2 V/3 V		0.05	0.12	V/μs
			DAC12AMPx = 2			
			DAC12AMPx = 3, 5	0.35	0.7	
	DAC12AMPx = 4, 6, 7		1.5	2.7		
Glitch energy, full scale	DAC12_xDAT = 80h → F7Fh → 80h	2.2 V/3 V		600		nV-s
			DAC12AMPx = 2			
			DAC12AMPx = 3, 5	150		
	DAC12AMPx = 4, 6, 7		30			

- NOTES: 1. R_{Load} and C_{Load} are connected to AV_{SS} (not AV_{CC}/2) in Figure 45.
 2. Slew rate applies to output voltage steps ≥ 200 mV.

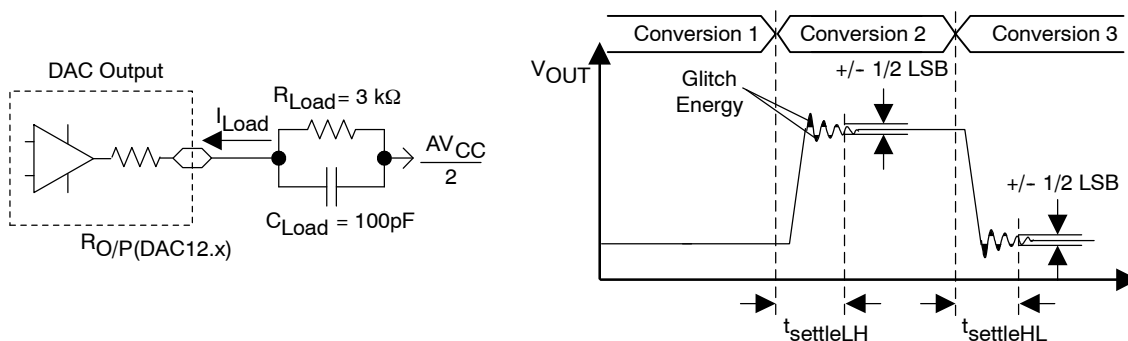

Figure 45. Settling Time and Glitch Energy Testing

electrical characteristics over recommended ranges of supply voltage and operating free-air temperature (unless otherwise noted) (continued)

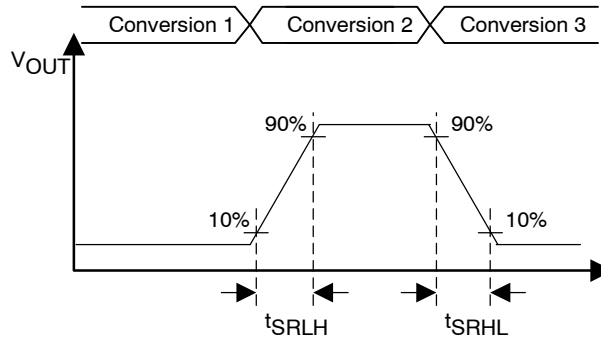

Figure 46. Slew Rate Testing

12-bit DAC, dynamic specifications (continued) ($T_A = 25^\circ\text{C}$, unless otherwise noted)

PARAMETER	TEST CONDITIONS	V_{CC}	MIN	TYP	MAX	UNIT
BW_{-3dB} 3-dB bandwidth, $V_{DC} = 1.5\text{ V}$, $V_{AC} = 0.1 V_{PP}$ (see Figure 47)	DAC12AMPx = {2, 3, 4}, DAC12SREFx = 2, DAC12IR = 1, DAC12_xDAT = 800h	2.2 V/3 V	40			kHz
	DAC12AMPx = {5, 6}, DAC12SREFx = 2, DAC12IR = 1, DAC12_xDAT = 800h		180			
	DAC12AMPx = 7, DAC12SREFx = 2, DAC12IR = 1, DAC12_xDAT = 800h		550			
Channel-to-channel crosstalk (see Note 1 and Figure 48)	DAC12_0DAT = 800h, No load, DAC12_1DAT = 80h->F7Fh, $R_{Load} = 3\text{ k}\Omega$, $f_{DAC12_1OUT} = 10\text{ kHz}$, Duty cycle = 50%	2.2 V/3 V		-80		dB
	DAC12_0DAT = 80h->F7Fh, $R_{Load} = 3\text{ k}\Omega$, DAC12_1DAT = 800h, No load, $f_{DAC12_0OUT} = 10\text{ kHz}$, Duty cycle = 50%			-80		

NOTE 1: $R_{LOAD} = 3\text{ k}\Omega$, $C_{LOAD} = 100\text{ pF}$

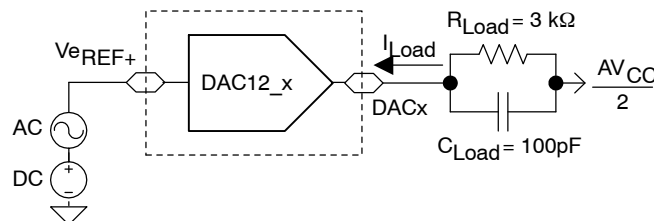

Figure 47. Test Conditions for 3-dB Bandwidth Specification

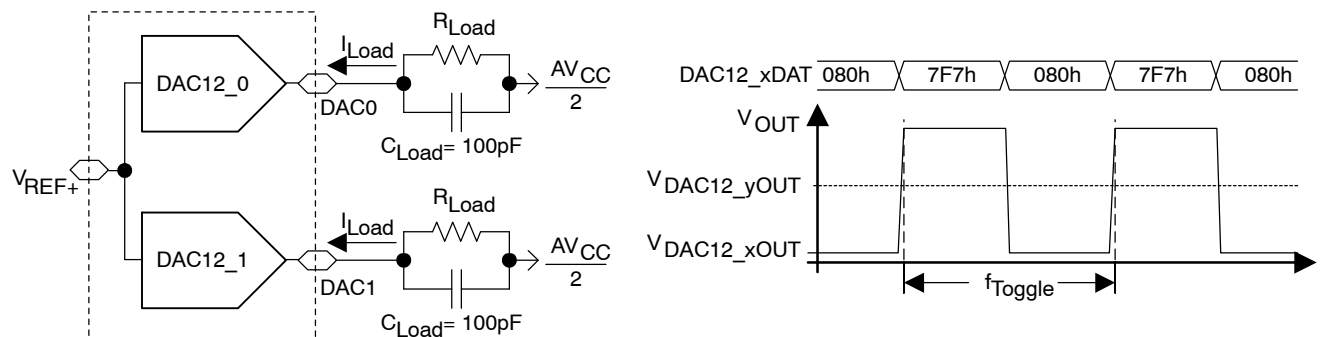

Figure 48. Crosstalk Test Conditions

MSP430F2618-EP MIXED SIGNAL MICROCONTROLLER

SLAS632 - DECEMBER 2008

electrical characteristics over recommended ranges of supply voltage and operating free-air temperature (unless otherwise noted) (continued)

flash memory

PARAMETER		TEST CONDITIONS	V _{CC}	MIN	TYP	MAX	UNIT
V _{CC(PGM/ERASE)}	Program and erase supply voltage			2.2		3.6	V
f _{FTG}	Flash Timing Generator frequency			257		476	kHz
I _{PGM}	Supply current from DV _{CC} during program		2.2 V/ 3.6 V		3	5	mA
I _{ERASE}	Supply current from DV _{CC} during erase		2.2 V/ 3.6 V		3	7	mA
t _{CPT}	Cumulative program time	See Note 1	2.2 V/ 3.6 V			10	ms
t _{CMerase}	Cumulative mass erase time	See Note 2	2.2 V/ 3.6 V	200			ms
	Program/Erase endurance			10 ⁴	10 ⁵		cycles
t _{Retention}	Data retention duration	T _J = 25°C		100			years
t _{Word}	Word or byte program time	See Note 3			35		t _{FTG}
t _{Block, 0}	Block program time for first byte or word	See Note 3			30		t _{FTG}
t _{Block, 1-63}	Block program time for each additional byte or word	See Note 3			21		t _{FTG}
t _{Block, End}	Block program end-sequence wait time	See Note 3			6		t _{FTG}
t _{Mass Erase}	Mass erase time (see Note 4)	See Note 3			10593		t _{FTG}
t _{Seg Erase}	Segment erase time	See Note 3			4819		t _{FTG}

- NOTES: 1. The cumulative program time must not be exceeded when writing to a 64-byte flash block. This parameter applies to all programming methods: individual word/byte write and block write modes.
2. The mass erase duration generated by the flash timing generator is at least 11.1 ms ($= 5297 \times 1/f_{FTG,max} = 5297 \times 1/476$ kHz). To achieve the required cumulative mass erase time, the Flash Controller's mass erase operation can be repeated until this time is met. A worst-case minimum of 19 cycles is required.
3. These values are hardwired into the Flash Controller's state machine ($t_{FTG} = 1/f_{FTG}$).
4. To erase the complete code area, the mass erase must be performed once with a dummy address in the range of the lower 64-kB flash addresses and once with the dummy address in the upper 64-kB flash addresses.

RAM

PARAMETER		TEST CONDITIONS	MIN	MAX	UNIT
VRAMh	See Note 1	CPU halted	1.6		V

NOTE 1: This parameter defines the minimum supply voltage when the data in program memory RAM remain unchanged. No program execution should take place during this supply voltage condition.



electrical characteristics over recommended operating free-air temperature (unless otherwise noted) (continued)

JTAG interface

PARAMETER		TEST CONDITIONS	V _{CC}	MIN	TYP	MAX	UNIT
f _{TCK}	TCK input frequency	See Note 1	2.2 V	0		5	MHz
			3 V	0		10	
R _{Internal}	Internal pullup resistance on TMS, TCK, TDI/TCLK	See Note 2	2.2 V/ 3 V	25	60	90	kΩ

- NOTES: 1. f_{TCK} may be restricted to meet the timing requirements of the module selected.
2. TMS, TDI/TCLK, and TCK pullup resistors are implemented in all versions.

JTAG fuse (see Note 1)

PARAMETER		TEST CONDITIONS	MIN	MAX	UNIT
V _{CC(FB)}	Supply voltage during fuse-blow condition	T _A = 25°C	2.5		V
V _{FB}	Voltage level on TDI/TCLK for fuse blow (F versions)		6	7	V
I _{FB}	Supply current into TDI/TCLK during fuse blow			100	mA
t _{FB}	Time to blow fuse			1	ms

NOTE 1: Once the fuse is blown, no further access to the MSP430 JTAG/Test and emulation features is possible. The JTAG block is switched to bypass mode.

MSP430F2618-EP MIXED SIGNAL MICROCONTROLLER

SLAS632 - DECEMBER 2008

APPLICATION INFORMATION

Port P1 pin schematic: P1.0 to P1.7, input/output with Schmitt trigger

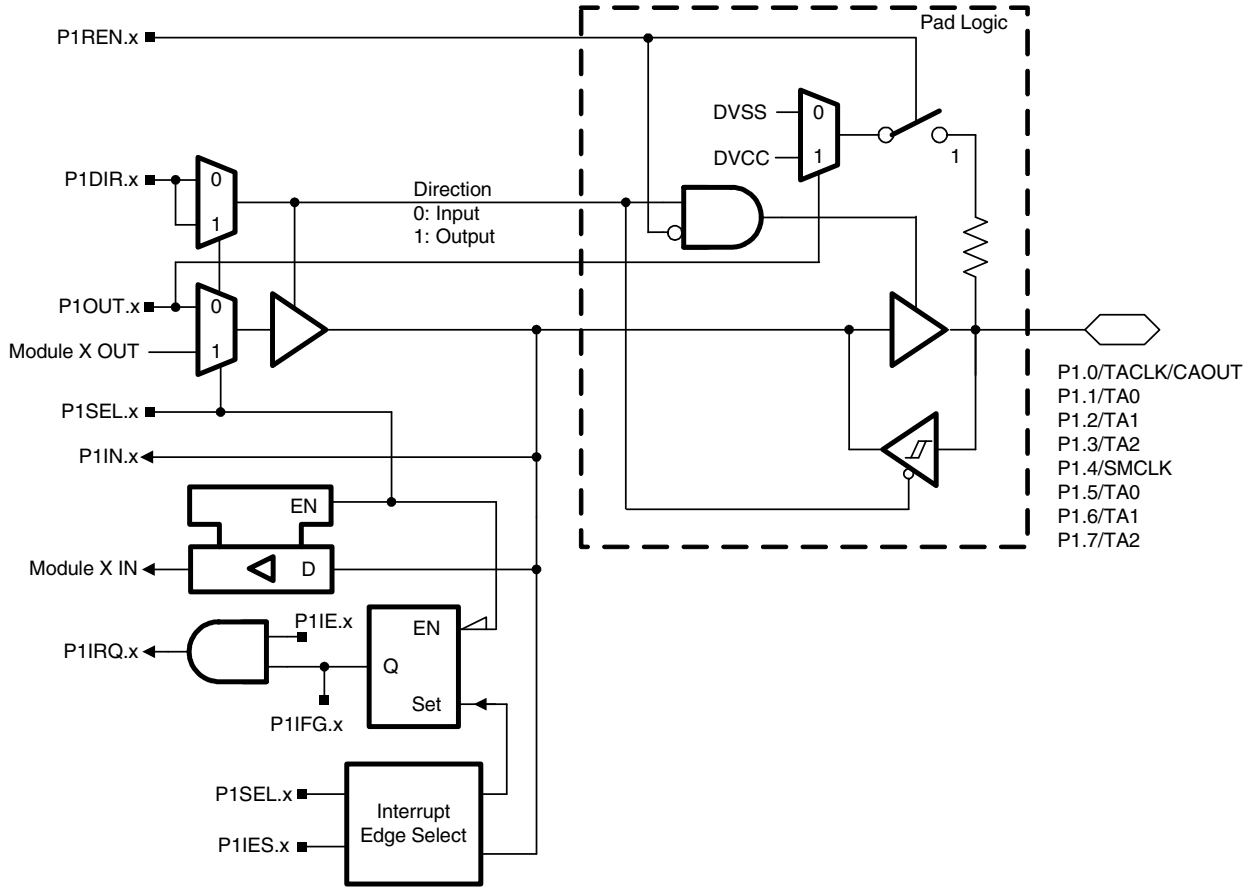

Port P1 (P1.0 to P1.7) pin functions

PIN NAME (P1.X)	X	FUNCTION	CONTROL BITS / SIGNALS	
			P1DIR.x	P1SEL.x
P1.0/TACLK	0	P1.0 (I/O)	I: 0; O: 1	0
		Timer_A3.TACLK	0	1
		CAOUT	1	1
P1.1/TA0	1	P1.1 (I/O)	I: 0; O: 1	0
		Timer_A3.CCI0A	0	1
		Timer_A3.TA0	1	1
P1.2/TA1	2	P1.2 (I/O)	I: 0; O: 1	0
		Timer_A3.CCI0A	0	1
		Timer_A3.TA0	1	1
P1.3/TA2	3	P1.3 (I/O)	I: 0; O: 1	0
		Timer_A3.CCI0A	0	1
		Timer_A3.TA0	1	1
P1.4/SMCLK	4	P1.4 (I/O)	I: 0; O: 1	0
		SMCLK	1	1
P1.5/TA0	5	P1.5 (I/O)	I: 0; O: 1	0
		Timer_A3.CCI0A	0	1
		Timer_A3.TA0	1	1
P1.6/TA1	6	P1.6 (I/O)	I: 0; O: 1	0
		Timer_A3.CCI0A	0	1
		Timer_A3.TA1	1	1
P1.7/TA2	7	P1.7 (I/O)	I: 0; O: 1	0
		Timer_A3.CCI0A	0	1
		Timer_A3.TA2	1	1

MSP430F2618-EP MIXED SIGNAL MICROCONTROLLER

SLAS632 - DECEMBER 2008

Port P2 pin schematic: P2.0 to P2.4, P2.6, and P2.7, input/output with Schmitt trigger

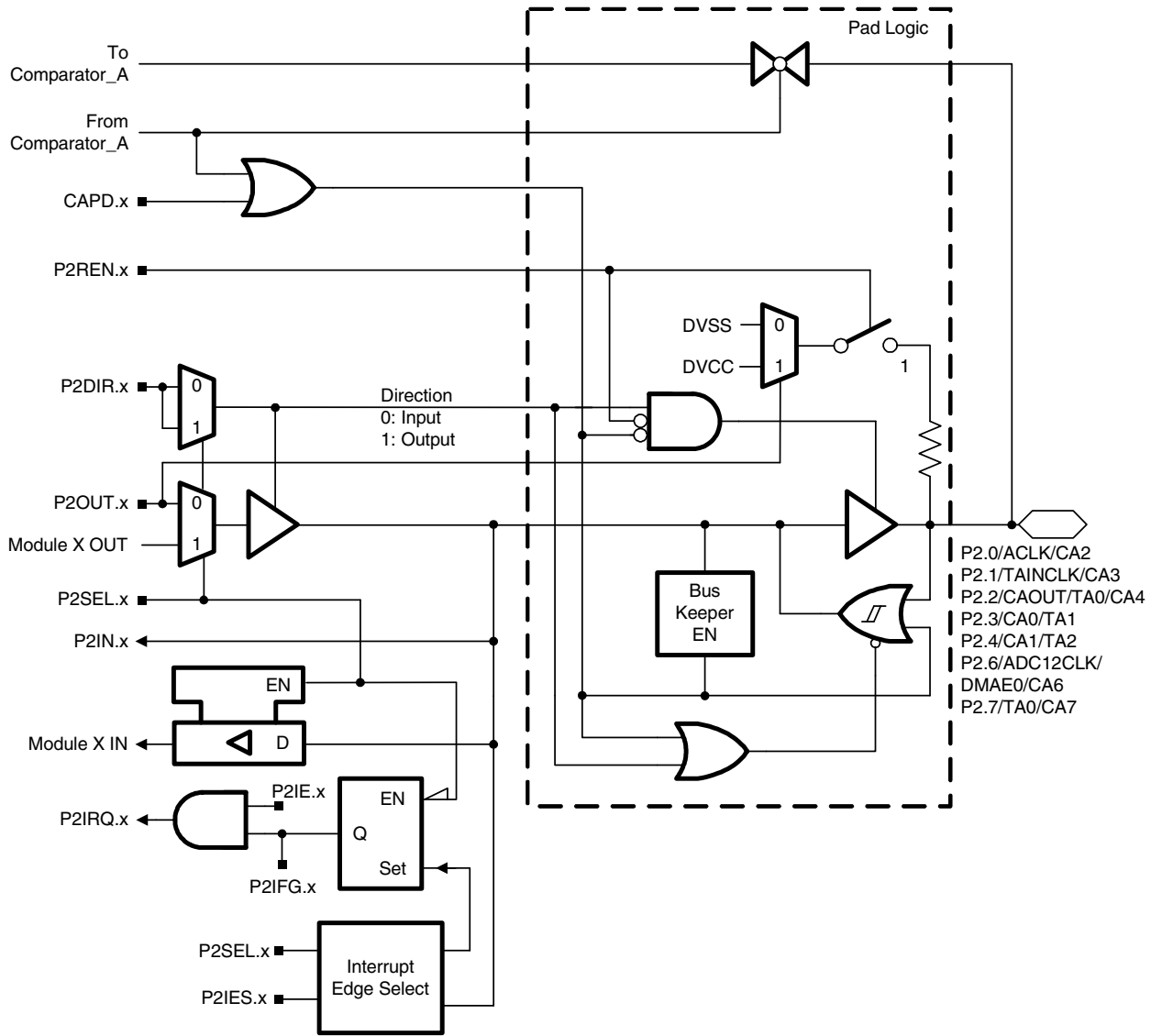

Port P2.0, P2.3, P2.4, P2.6 and P2.7 pin functions

PIN NAME (P2.X)	X	FUNCTION	CONTROL BITS / SIGNALS		
			CAPD.x	P2DIR.x	P2SEL.x
P2.0/ACLK/CA2	0	P2.0 (I/O)	0	I: 0; O: 1	0
		ACLK	0	1	1
		CA2	1	X	X
P2.1/TAINCLK/CA3	1	P2.1 (I/O)	0	I: 0; O: 1	0
		Timer_A3.INCLK	0	0	1
		DV _{SS}	0	1	1
		CA3	1	X	X
P2.2/CAOUT/TA0/CA4	2	P2.2 (I/O)	0	I: 0; O: 1	0
		CAOUT	0	1	1
		TA0	0	0	1
		CA4	1	X	X
P2.3/CA0/TA1	3	P2.3 (I/O)	0	I: 0; O: 1	0
		Timer_A3.TA1	0	1	1
		CA0	1	X	X
P2.4/CA1/TA2	4	P2.4 (I/O)	0	I: 0; O: 1	0
		Timer_A3.TA2	0	1	X
		CA1	1	X	1
P2.6/ADC12CLK/DMAE0/CA6	6	P2.6 (I/O)	0	I: 0; O: 1	0
		ADC12CLK	0	1	1
		DMAE0	0	0	1
		CA6	1	X	X
P2.7/TA0/CA7	7	P2.7 (I/O)	0	I: 0; O: 1	0
		Timer_A3.TA0	0	1	1
		CA7	1	X	X

NOTE: X: Don't care.

MSP430F2618-EP MIXED SIGNAL MICROCONTROLLER

SLAS632 - DECEMBER 2008

Port P2 pin schematic: P2.5, input/output with Schmitt trigger

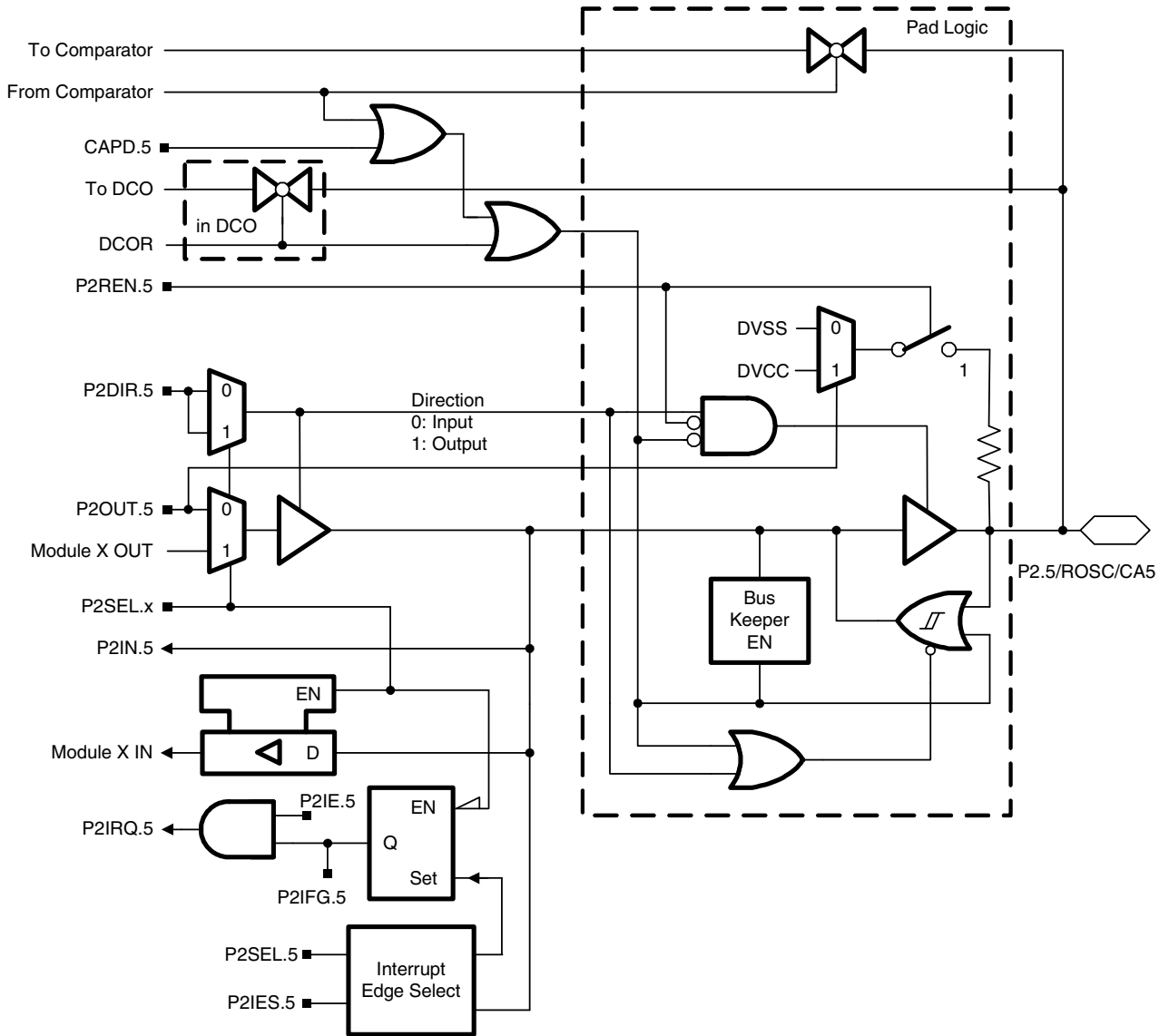

Port P2.5 pin functions

PIN NAME (P2.X)	X	FUNCTION	CONTROL BITS / SIGNALS			
			CAPD	DCOR	P2DIR.5	P2SEL.5
P2.5/Rosc/CA5	5	P2.5 (I/O)	0	0	I: 0; O: 1	0
		Rosc (see Note 2)	0	1	X	X
		DV _{SS}	0	0	1	1
		CA5	1 or selected	0	X	X

NOTES: 1. X: Don't care.
2. If Rosc is used it is connected to an external resistor.

MSP430F2618-EP MIXED SIGNAL MICROCONTROLLER

SLAS632 - DECEMBER 2008

Port P4 pin schematic: P4.0 to P4.7, input/output with Schmitt trigger

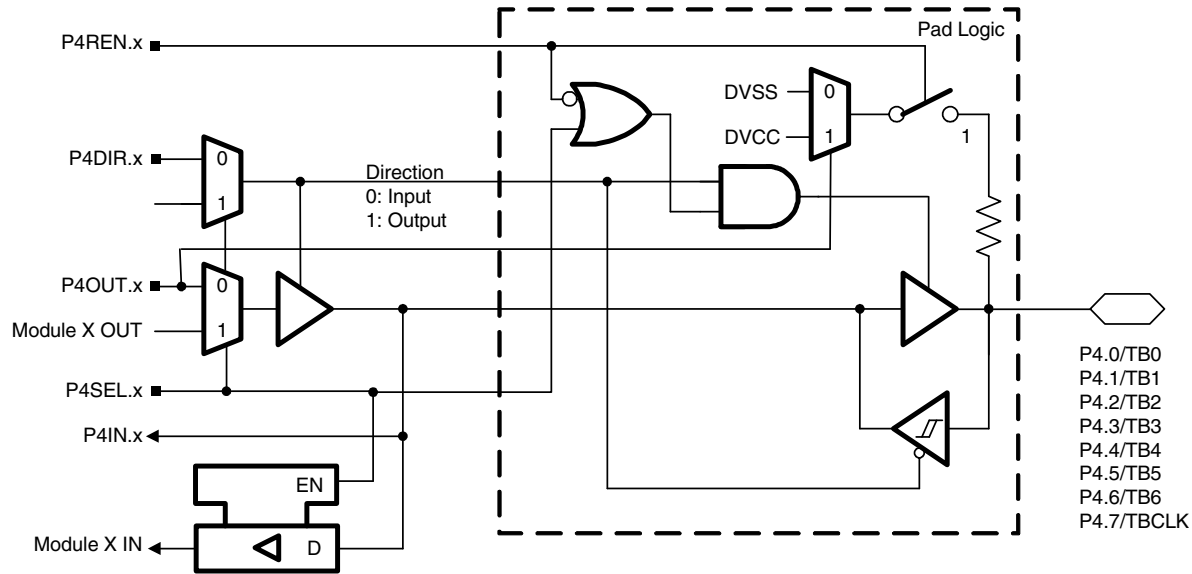

Port P4.0 to P4.7 pin functions

PIN NAME (P4.X)	X	FUNCTION	CONTROL BITS / SIGNALS	
			P4DIR.x	P4SEL.x
P4.0/TB0	0	P4.0 (I/O)	I: 0; O: 1	0
		Timer_B7.CCI0A and Timer_B7.CCI0B	0	1
		Timer_B7.TB0	1	1
P4.1/TB1	1	P4.1 (I/O)	I: 0; O: 1	0
		Timer_B7.CCI1A and Timer_B7.CCI1B	0	1
		Timer_B7.TB1	1	1
P4.2/TB2	2	P4.2 (I/O)	I: 0; O: 1	0
		Timer_B7.CCI2A and Timer_B7.CCI2B	0	1
		Timer_B7.TB2	1	1
P4.3/TB3	3	P4.3 (I/O)	I: 0; O: 1	0
		Timer_B7.CCI3A and Timer_B7.CCI3B	0	1
		Timer_B7.TB3	1	1
P4.4/TB4	4	P4.4 (I/O)	I: 0; O: 1	0
		Timer_B7.CCI4A and Timer_B7.CCI4B	0	1
		Timer_B7.TB4	1	1
P4.5/TB5	5	P4.5 (I/O)	I: 0; O: 1	0
		Timer_B7.CCI5A and Timer_B7.CCI5B	0	1
		Timer_B7.TB5	1	1
P4.6/TB6	6	P4.6 (I/O)	I: 0; O: 1	0
		Timer_B7.CCI6A and Timer_B7.CCI6B	0	1
		Timer_B7.TB6	1	1
P4.7/TBCLK	7	P4.7 (I/O)	I: 0; O: 1	0
		Timer_B7.TBCLK	1	1

Port P5 pin schematic: P5.0 to P5.7, input/output with Schmitt trigger

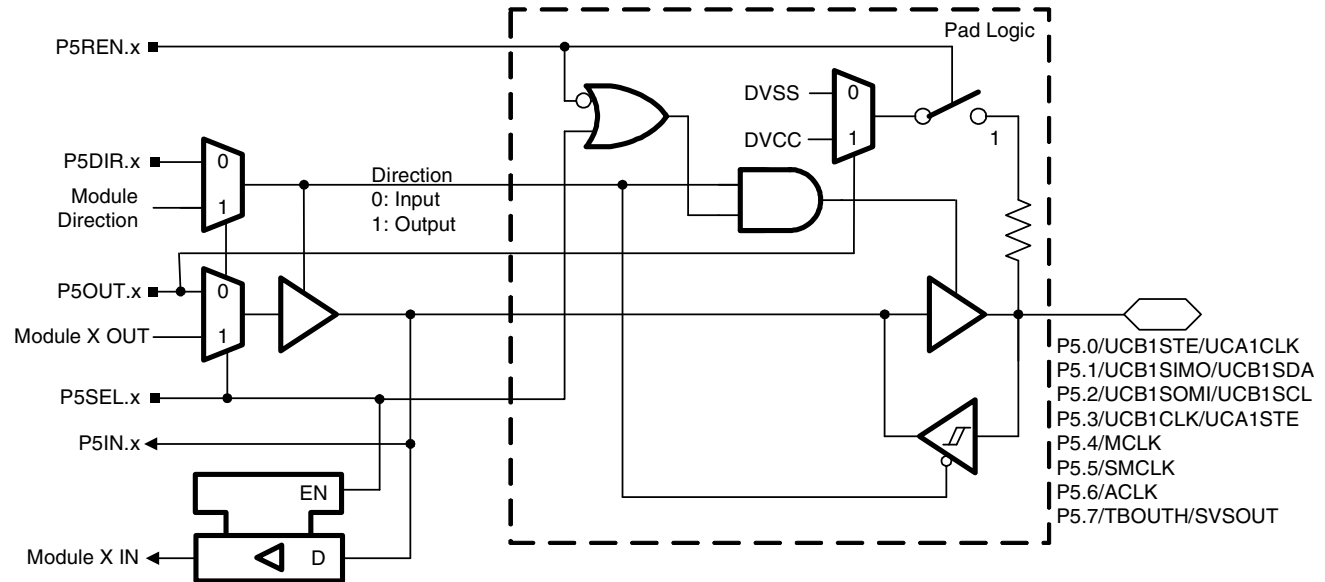

Port P5.0 to P5.7 pin functions

PIN NAME (P5.X)	X	FUNCTION	CONTROL BITS / SIGNALS	
			P5DIR.x	P5SEL.x
P5.0/UCB1STE/ UCA1CLK	0	P5.0 (I/O)	I: 0; O: 1	0
		UCB1STE/UCA1CLK (see Note 2 and 4)	X	1
P5.1/UCB1SIMO/ UCB1SDA	1	P5.1 (I/O)	I: 0; O: 1	0
		UCB1SIMO/UCB1SDA (see Note 2 and 3)	X	1
P5.2/UCB1SOMI/ UCB1SCL	2	P5.2 (I/O)	I: 0; O: 1	0
		UCB1SOMI/UCB1SCL (see Note 2 and 3)	X	1
P5.3/UCB1CLK/ UCA1STE	3	P5.3 (I/O)	I: 0; O: 1	0
		UCB1CLK/UCA1STE (see Note 2)	X	1
P5.4/MCLK	4	P5.0 (I/O)	I: 0; O: 1	0
		MCLK	1	1
P5.5/SMCLK	5	P5.1 (I/O)	I: 0; O: 1	0
		SMCLK	1	1
P5.6/ACLK	6	P5.2 (I/O)	I: 0; O: 1	0
		ACLK	1	1
P5.7/TBOUTH/ SVSOUT	7	P5.7 (I/O)	I: 0; O: 1	0
		TBOUTH	0	1
		SVSOUT	1	1

- NOTES: 1. X: Don't care.
 2. The pin direction is controlled by the USCI module.
 3. In case the I2C functionality is selected the output drives only the logical 0 to V_{SS} level.
 4. UCA1CLK function takes precedence over UCB1STE function. If the pin is required as UCA1CLK input or output USCI A1/B1 will be forced to 3-wire SPI mode if 4-wire SPI mode is selected.

MSP430F2618-EP MIXED SIGNAL MICROCONTROLLER

SLAS632 - DECEMBER 2008

Port P6 pin schematic: P6.0 to P6.4, input/output with Schmitt trigger

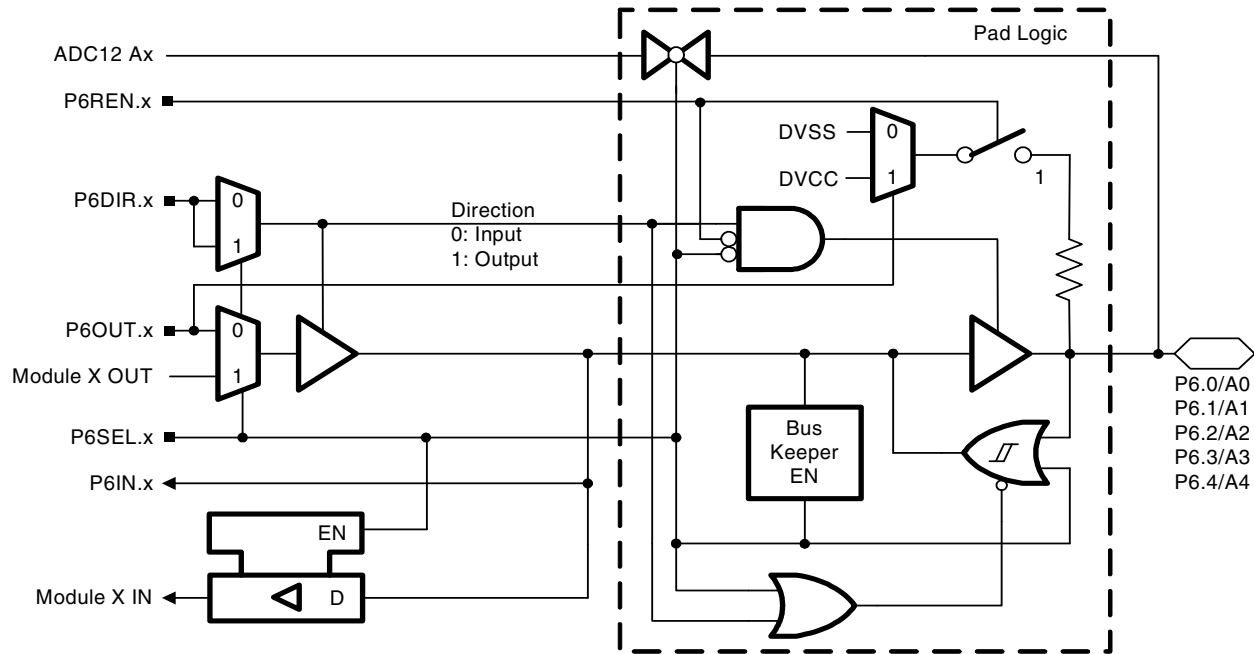

Port P6.0 to P6.4 pin functions

PIN NAME (P6.X)	X	FUNCTION	CONTROL BITS / SIGNALS	
			P6DIR.x	P6SEL.x
P6.0/A0	0	P6.0 (I/O)	I: 0; O: 1	0
		A0 (see Note 2)	X	X
P6.1/A1	1	P6.1 (I/O)	I: 0; O: 1	0
		A1 (see Note 2)	X	X
P6.2/A2	2	P6.2 (I/O)	I: 0; O: 1	0
		A2 (see Note 2)	X	X
P6.3/A3	3	P6.3 (I/O)	I: 0; O: 1	0
		A3 (see Note 2)	X	X
P6.4/A4	4	P6.4 (I/O)	I: 0; O: 1	0
		A4 (see Note 2)	X	X

NOTES: 1. X: Don't care.
2. The ADC12 channel Ax is connected to AVss internally if not selected.

Port P6 pin schematic: P6.5 and P6.6, input/output with Schmitt trigger

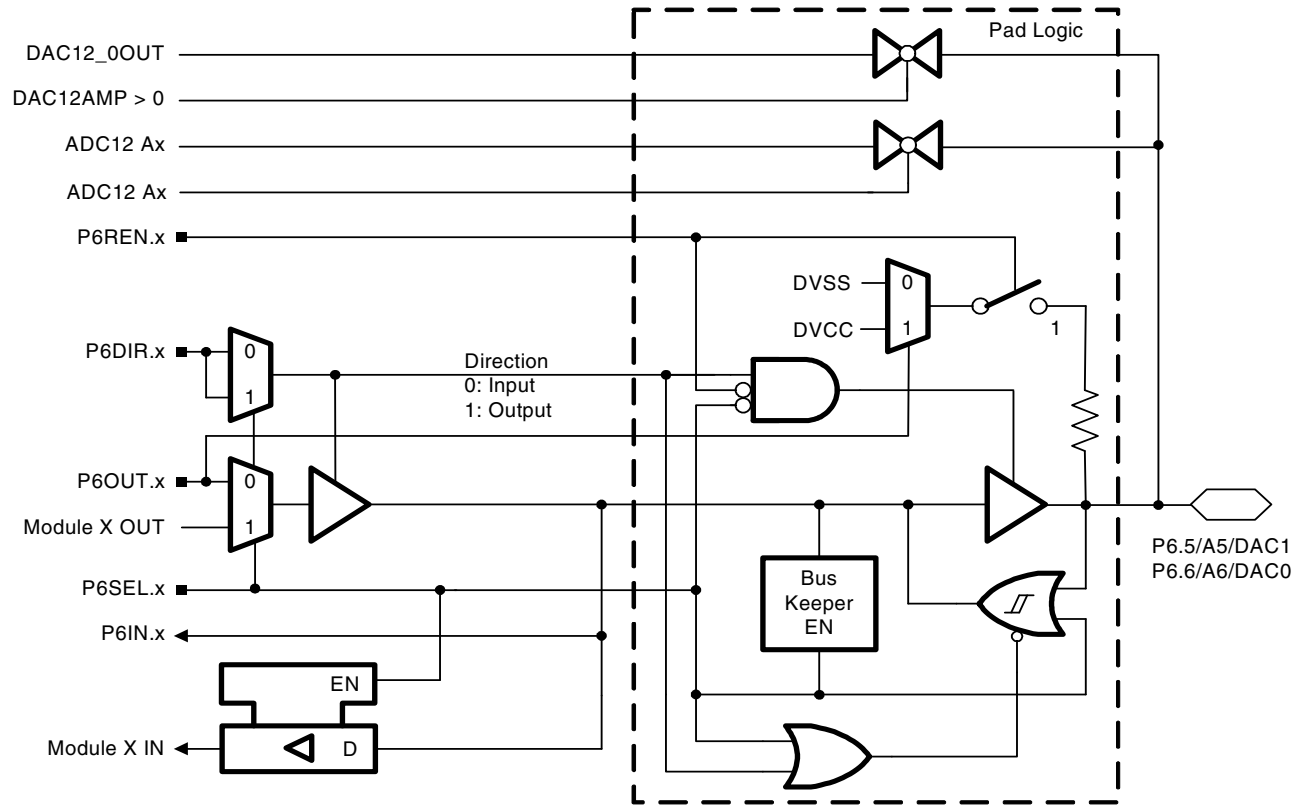

Port P6.5 to P6.6 pin functions

PIN NAME (P6.X)	X	FUNCTION	CONTROL BITS / SIGNALS		
			P6DIR.x	P6SEL.x	CAPD.x or DAC12AMP > 0
P6.5/A5/DAC1†	5	P6.5 (I/O)	I: 0; O: 1	0	0
		DV _{SS}	1	1	0
		A5 (see Note 2)	X	X	1
		DAC1 (DA12OPS= 1, see Note 3)	X	X	1
P6.6/A6/DAC0†	6	P6.6 (I/O)	I: 0; O: 1	0	0
		DV _{SS}	1	1	0
		A6 (see Note 2)	X	X	1
		DAC0 (DA12OPS= 0, see Note 3)	X	X	1

† MSP430F261x devices only

NOTES: 1. X: Don't care.

2. The ADC12 channel Ax is connected to AV_{SS} internally if not selected.

3. The DAC outputs are floating if not selected.

MSP430F2618-EP MIXED SIGNAL MICROCONTROLLER

SLAS632 - DECEMBER 2008

Port P6 pin schematic: P6.7, input/output with Schmitt trigger

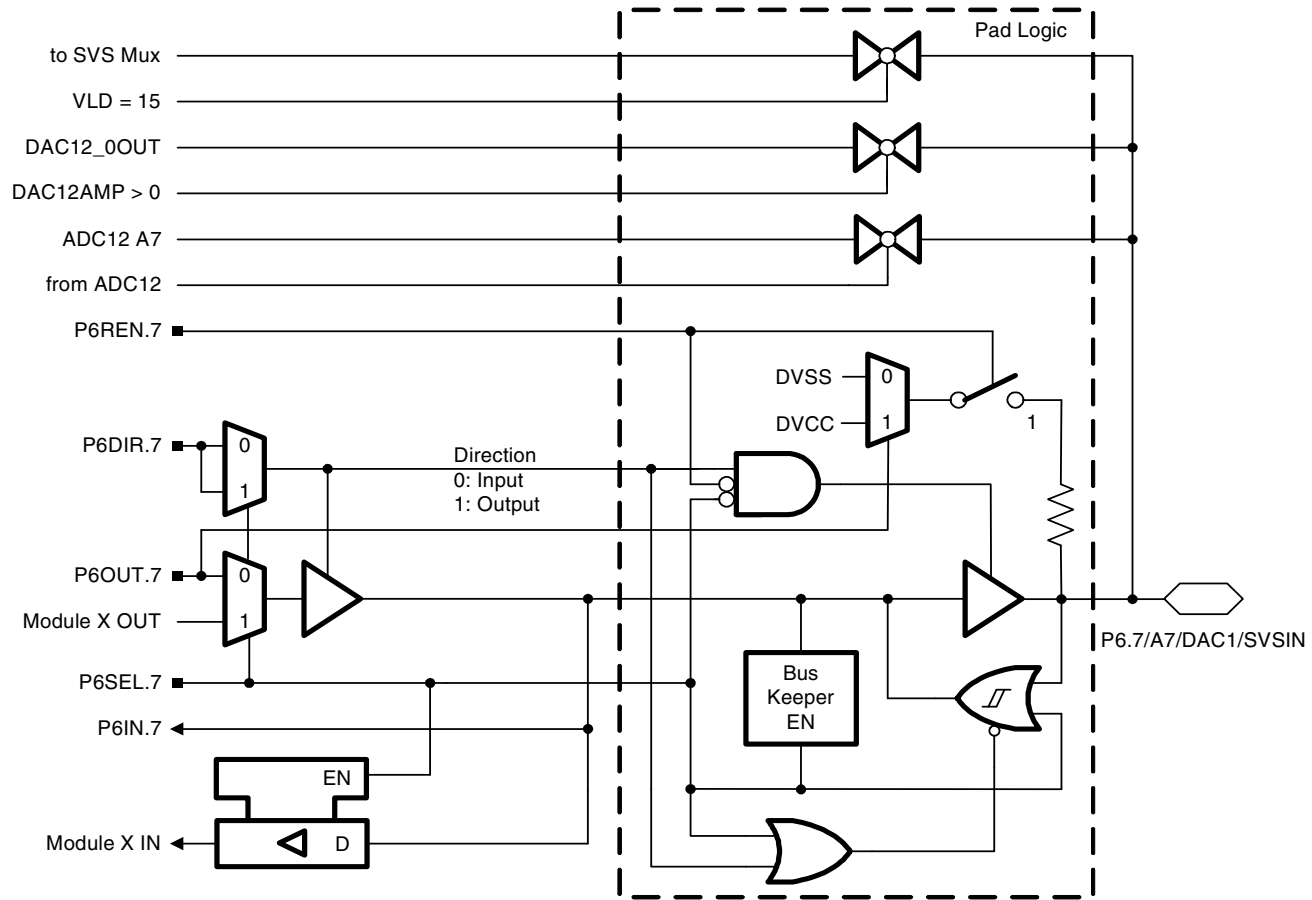

Port P6.7 pin functions

PIN NAME (P6.X)	X	FUNCTION	CONTROL BITS / SIGNALS	
			P6DIR.x	P6SEL.x
P6.7/A7/DAC1†/ SVSIN†	7	P6.7 (I/O)	I: 0; O: 1	0
		DV _{SS}	1	1
		A7 (see Note 2)	X	X
		DAC1 (DA12OPS= 0, see Note 3)	X	X
		SVSIN (VLD = 15)	X	X

- NOTES: 1. X: Don't care.
 2. The ADC12 channel Ax is connected to AV_{SS} internally if not selected.
 3. The DAC outputs are floating if not selected.

† MSP430F261x devices only

Port P7 pin schematic: P7.0 to P7.7, input/output with Schmitt trigger†

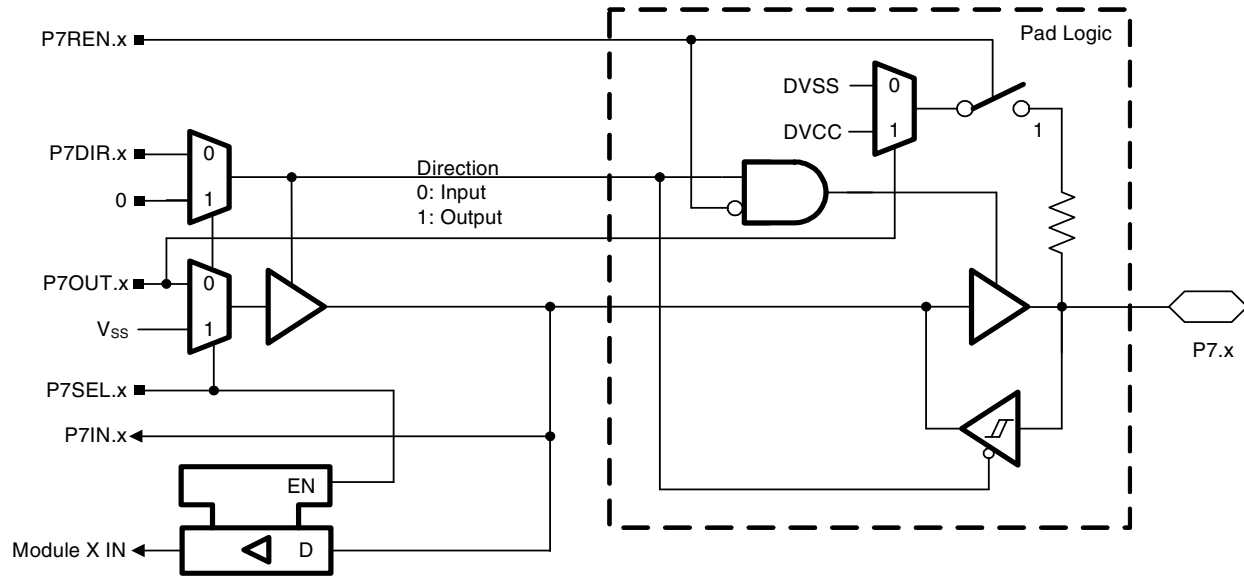

Port P7.0 to P7.7 pin functions†

PIN NAME (P7.X)	X	FUNCTION	CONTROL BITS / SIGNALS	
			P7DIR.x	P7SEL.x
P7.0	0	P7.0 (I/O)	I: 0; O: 1	0
		Input	X	1
P7.1	1	P7.1 (I/O)	I: 0; O: 1	0
		Input	X	1
P7.2	2	P7.2 (I/O)	I: 0; O: 1	0
		Input	X	1
P7.3	3	P7.3 (I/O)	I: 0; O: 1	0
		Input	X	1
P7.4	4	P7.4 (I/O)	I: 0; O: 1	0
		Input	X	1
P7.5	5	P7.5 (I/O)	I: 0; O: 1	0
		Input	X	1
P7.6	6	P7.6 (I/O)	I: 0; O: 1	0
		Input	X	1
P7.7	7	P7.7 (I/O)	I: 0; O: 1	0
		Input	X	1

† 80-pin devices only

MSP430F2618-EP MIXED SIGNAL MICROCONTROLLER

SLAS632 - DECEMBER 2008

Port P8 pin schematic: P8.0 to P8.5, input/output with Schmitt trigger†

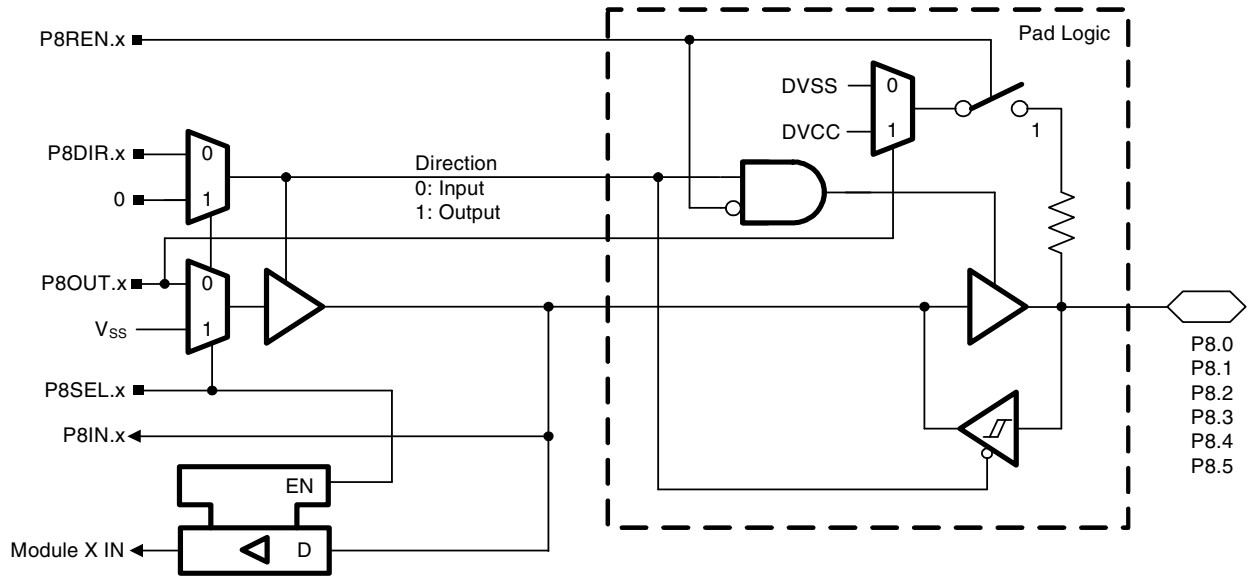

Port P8.0 to P8.5 pin functions†

PIN NAME (P8.X)	X	FUNCTION	CONTROL BITS / SIGNALS	
			P8DIR.x	P8SEL.x
P8.0	0	P8.0 (I/O)	I: 0; O: 1	0
		Input	X	1
P8.1	1	P8.1 (I/O)	I: 0; O: 1	0
		Input	X	1
P8.2	2	P8.2 (I/O)	I: 0; O: 1	0
		Input	X	1
P8.3	3	P8.3 (I/O)	I: 0; O: 1	0
		Input	X	1
P8.4	4	P8.4 (I/O)	I: 0; O: 1	0
		Input	X	1
P8.5	5	P8.5 (I/O)	I: 0; O: 1	0
		Input	X	1

† 80-pin devices only

MSP430F2618-EP MIXED SIGNAL MICROCONTROLLER

SLAS632 - DECEMBER 2008

Port P8 pin schematic: P8.7, input/output with Schmitt trigger†

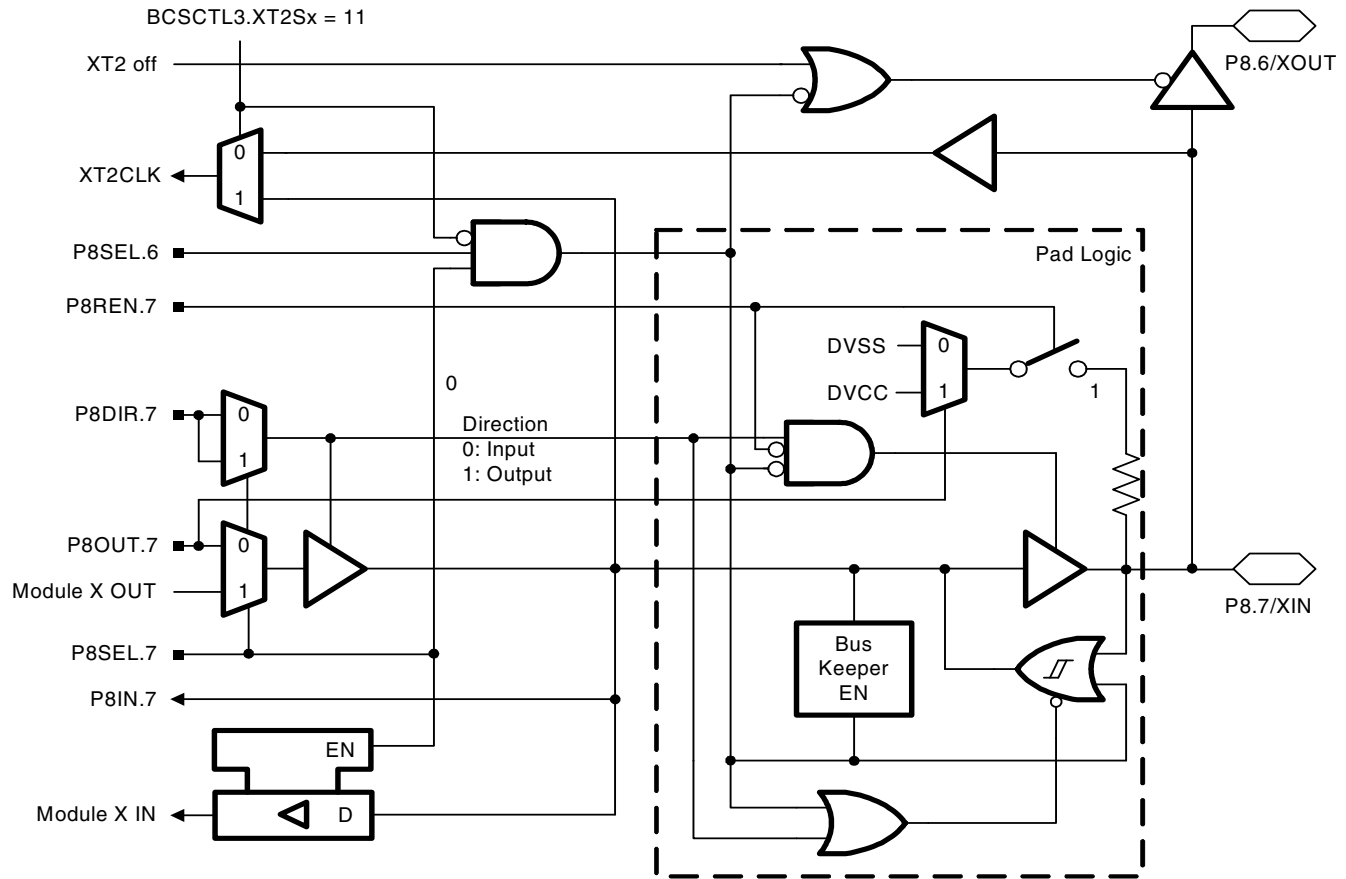

Port P8.7 pin functions†

PIN NAME (P8.X)	X	FUNCTION	CONTROL BITS / SIGNALS	
			P8DIR.x	P8SEL.x
P8.7/XIN	7	P8.7 (I/O)	I: 0; O: 1	0
		XIN (default)	0	1
		V _{SS}	1	1

† 80-pin devices only

APPLICATION INFORMATION

JTAG pins: TMS, TCK, TDI/TCLK, TDO/TDI, input/output with Schmitt trigger

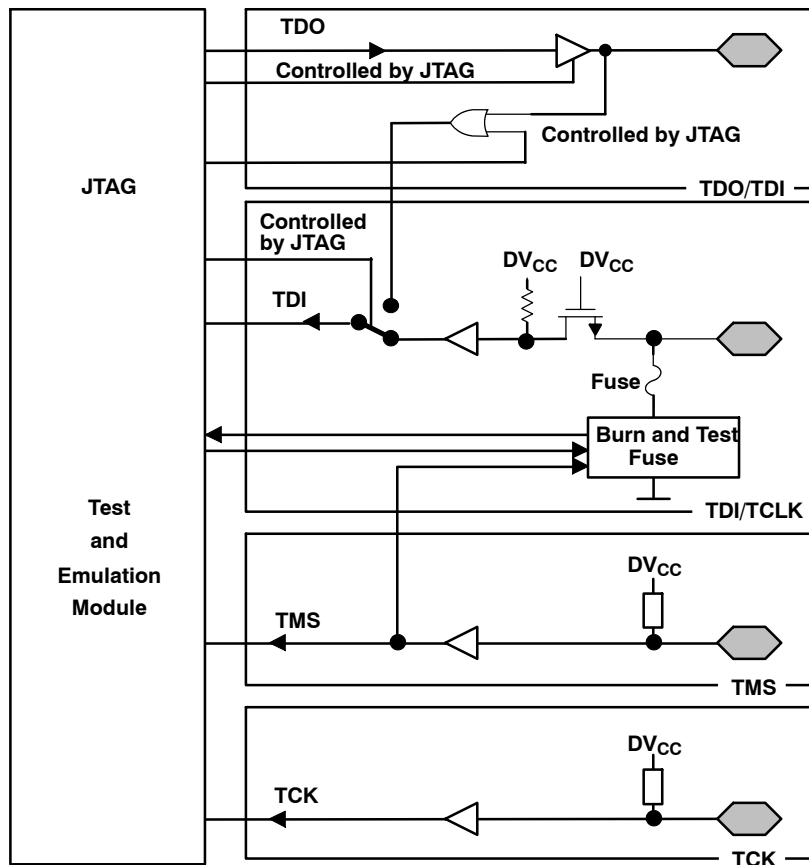

During Programming Activity and During Blowing of the Fuse, Pin TDO/TDI Is Used to Apply the Test Input Data for JTAG Circuitry

APPLICATION INFORMATION

JTAG fuse check mode

MSP430 devices that have the fuse on the TDI/TCLK terminal have a fuse check mode that tests the continuity of the fuse the first time the JTAG port is accessed after a power-on reset (POR). When activated, a fuse check current, I_{TF} , of 1 mA at 3 V or 2.5 mA at 5 V can flow from the TDI/TCLK pin to ground if the fuse is not burned. Care must be taken to avoid accidentally activating the fuse check mode and increasing overall system power consumption.

Activation of the fuse check mode occurs with the first negative edge on the TMS pin after power up or if the TMS is being held low during power up. The second positive edge on the TMS pin deactivates the fuse check mode. After deactivation, the fuse check mode remains inactive until another POR occurs. After each POR the fuse check mode has the potential to be activated.

The fuse check current flows only when the fuse check mode is active and the TMS pin is in a low state (see Figure 49). Therefore, the additional current flow can be prevented by holding the TMS pin high (default condition).

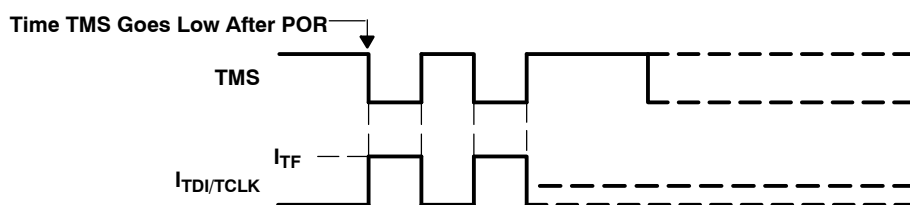

Figure 49. Fuse Check Mode Current

Data Sheet Revision History

LITERATURE NUMBER	SUMMARY
SLAS541	Product Preview release
SLAS541A	Production Data release Corrected the format and the content shown on the first page. Corrected pin number of P3.6 and P3.7 in 64-pin package in the terminal function list. Corrected the port schematics. Corrected "calibration data" section (page 20). Typos and formatting corrected. Added the figure "typical characteristics - LPM4 current" (Page 33).
SLAS541B	Added preview of MSP430F261x BGA devices.
SLAS541C	Release to market of MSP430F261x BGA devices
SLAS541D	Added the ESD disclaimer (page 1). Added reserved BGA pins to the terminal function list (pages 10 and following). Corrected the references in the output port parameters (page 36). Corrected the cumulative program time of the flash (page 75).

PACKAGING INFORMATION

Orderable Device	Status ⁽¹⁾	Package Type	Package Drawing	Pins	Package Qty	Eco Plan ⁽²⁾	Lead/Ball Finish	MSL Peak Temp ⁽³⁾
MSP430F2618TGQWTEP	ACTIVE	BGA MI CROSTA R JUNI OR	GQW	113	250	TBD	SNPB	Level-3-235C-168 HR
V62/09620-01XA	ACTIVE	BGA MI CROSTA R JUNI OR	GQW	113	250	TBD	SNPB	Level-3-235C-168 HR

⁽¹⁾ The marketing status values are defined as follows:

ACTIVE: Product device recommended for new designs.

LIFEBUY: TI has announced that the device will be discontinued, and a lifetime-buy period is in effect.

NRND: Not recommended for new designs. Device is in production to support existing customers, but TI does not recommend using this part in a new design.

PREVIEW: Device has been announced but is not in production. Samples may or may not be available.

OBSOLETE: TI has discontinued the production of the device.

⁽²⁾ Eco Plan - The planned eco-friendly classification: Pb-Free (RoHS), Pb-Free (RoHS Exempt), or Green (RoHS & no Sb/Br) - please check <http://www.ti.com/productcontent> for the latest availability information and additional product content details.

TBD: The Pb-Free/Green conversion plan has not been defined.

Pb-Free (RoHS): TI's terms "Lead-Free" or "Pb-Free" mean semiconductor products that are compatible with the current RoHS requirements for all 6 substances, including the requirement that lead not exceed 0.1% by weight in homogeneous materials. Where designed to be soldered at high temperatures, TI Pb-Free products are suitable for use in specified lead-free processes.

Pb-Free (RoHS Exempt): This component has a RoHS exemption for either 1) lead-based flip-chip solder bumps used between the die and package, or 2) lead-based die adhesive used between the die and leadframe. The component is otherwise considered Pb-Free (RoHS compatible) as defined above.

Green (RoHS & no Sb/Br): TI defines "Green" to mean Pb-Free (RoHS compatible), and free of Bromine (Br) and Antimony (Sb) based flame retardants (Br or Sb do not exceed 0.1% by weight in homogeneous material)

⁽³⁾ MSL, Peak Temp. -- The Moisture Sensitivity Level rating according to the JEDEC industry standard classifications, and peak solder temperature.

Important Information and Disclaimer:The information provided on this page represents TI's knowledge and belief as of the date that it is provided. TI bases its knowledge and belief on information provided by third parties, and makes no representation or warranty as to the accuracy of such information. Efforts are underway to better integrate information from third parties. TI has taken and continues to take reasonable steps to provide representative and accurate information but may not have conducted destructive testing or chemical analysis on incoming materials and chemicals. TI and TI suppliers consider certain information to be proprietary, and thus CAS numbers and other limited information may not be available for release.

In no event shall TI's liability arising out of such information exceed the total purchase price of the TI part(s) at issue in this document sold by TI to Customer on an annual basis.

OTHER QUALIFIED VERSIONS OF MSP430F2618-EP :

- Catalog: [MSP430F2618](#)

NOTE: Qualified Version Definitions:

- Catalog - TI's standard catalog product

GQW (S-PBGA-N113)

PLASTIC BALL GRID ARRAY

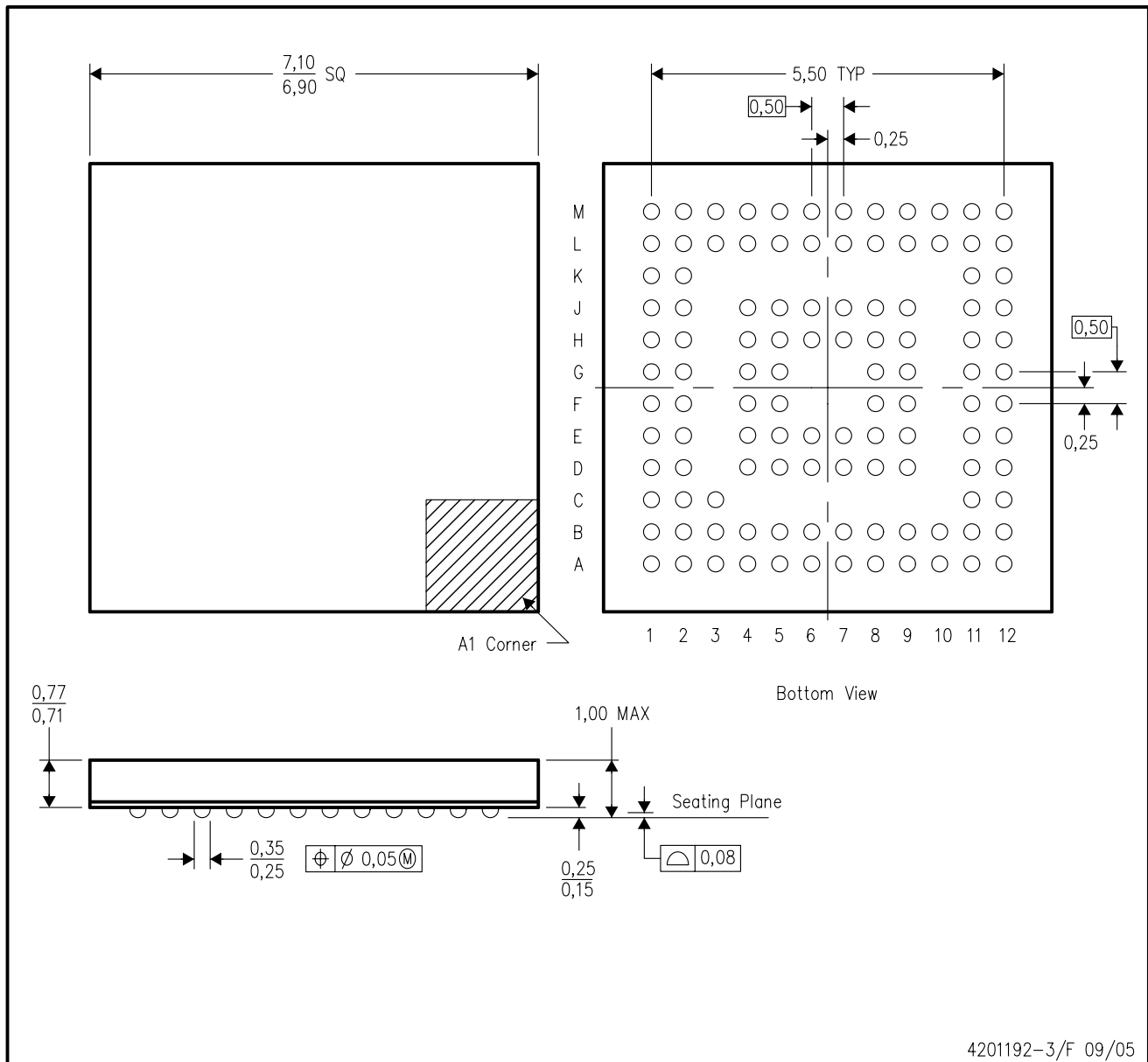

- NOTES:
- A. All linear dimensions are in millimeters.
 - B. This drawing is subject to change without notice.
 - C. Falls within JEDEC MO-225

IMPORTANT NOTICE

Texas Instruments Incorporated and its subsidiaries (TI) reserve the right to make corrections, modifications, enhancements, improvements, and other changes to its products and services at any time and to discontinue any product or service without notice. Customers should obtain the latest relevant information before placing orders and should verify that such information is current and complete. All products are sold subject to TI's terms and conditions of sale supplied at the time of order acknowledgment.

TI warrants performance of its hardware products to the specifications applicable at the time of sale in accordance with TI's standard warranty. Testing and other quality control techniques are used to the extent TI deems necessary to support this warranty. Except where mandated by government requirements, testing of all parameters of each product is not necessarily performed.

TI assumes no liability for applications assistance or customer product design. Customers are responsible for their products and applications using TI components. To minimize the risks associated with customer products and applications, customers should provide adequate design and operating safeguards.

TI does not warrant or represent that any license, either express or implied, is granted under any TI patent right, copyright, mask work right, or other TI intellectual property right relating to any combination, machine, or process in which TI products or services are used. Information published by TI regarding third-party products or services does not constitute a license from TI to use such products or services or a warranty or endorsement thereof. Use of such information may require a license from a third party under the patents or other intellectual property of the third party, or a license from TI under the patents or other intellectual property of TI.

Reproduction of TI information in TI data books or data sheets is permissible only if reproduction is without alteration and is accompanied by all associated warranties, conditions, limitations, and notices. Reproduction of this information with alteration is an unfair and deceptive business practice. TI is not responsible or liable for such altered documentation. Information of third parties may be subject to additional restrictions.

Resale of TI products or services with statements different from or beyond the parameters stated by TI for that product or service voids all express and any implied warranties for the associated TI product or service and is an unfair and deceptive business practice. TI is not responsible or liable for any such statements.

TI products are not authorized for use in safety-critical applications (such as life support) where a failure of the TI product would reasonably be expected to cause severe personal injury or death, unless officers of the parties have executed an agreement specifically governing such use. Buyers represent that they have all necessary expertise in the safety and regulatory ramifications of their applications, and acknowledge and agree that they are solely responsible for all legal, regulatory and safety-related requirements concerning their products and any use of TI products in such safety-critical applications, notwithstanding any applications-related information or support that may be provided by TI. Further, Buyers must fully indemnify TI and its representatives against any damages arising out of the use of TI products in such safety-critical applications.

TI products are neither designed nor intended for use in military/aerospace applications or environments unless the TI products are specifically designated by TI as military-grade or "enhanced plastic." Only products designated by TI as military-grade meet military specifications. Buyers acknowledge and agree that any such use of TI products which TI has not designated as military-grade is solely at the Buyer's risk, and that they are solely responsible for compliance with all legal and regulatory requirements in connection with such use.

TI products are neither designed nor intended for use in automotive applications or environments unless the specific TI products are designated by TI as compliant with ISO/TS 16949 requirements. Buyers acknowledge and agree that, if they use any non-designated products in automotive applications, TI will not be responsible for any failure to meet such requirements.

Following are URLs where you can obtain information on other Texas Instruments products and application solutions:

Products

Amplifiers	amplifier.ti.com
Data Converters	dataconverter.ti.com
DLP® Products	www.dlp.com
DSP	dsp.ti.com
Clocks and Timers	www.ti.com/clocks
Interface	interface.ti.com
Logic	logic.ti.com
Power Mgmt	power.ti.com
Microcontrollers	microcontroller.ti.com
RFID	www.ti-rfid.com
RF/IF and ZigBee® Solutions	www.ti.com/lprf

Applications

Audio	www.ti.com/audio
Automotive	www.ti.com/automotive
Broadband	www.ti.com/broadband
Digital Control	www.ti.com/digitalcontrol
Medical	www.ti.com/medical
Military	www.ti.com/military
Optical Networking	www.ti.com/opticalnetwork
Security	www.ti.com/security
Telephony	www.ti.com/telephony
Video & Imaging	www.ti.com/video
Wireless	www.ti.com/wireless

Mailing Address: Texas Instruments, Post Office Box 655303, Dallas, Texas 75265
Copyright © 2009, Texas Instruments Incorporated

Looking for pricing, stock, or lifecycle information?

Click below to explore more details on WIN SOURCE:

- ⊖ [View MSP430F2618TGQWTEP](#) on WIN SOURCE
- ⊖ [Texas Instruments](#) Information

Optimize Your Supply Chain with WIN SOURCE Solutions

- ✓ Global Sourcing Solution
- ✓ Obsolete Management
- ✓ Cost Control Management
- ✓ Shortage Management
- ✓ Alternative Solution
- ✓ Excess Inventory Management