



THE DATASHEET OF MOD-MPU9150





InvenSense Inc.

1197 Borregas Ave, Sunnyvale, CA 94089 U.S.A.
Tel: +1 (408) 988-7339 Fax: +1 (408) 988-8104
Website: www.invensense.com

Document Number: PS-MPU-9150A-00
Revision: 4.3
Release Date: 9/18/2013

MPU-9150

Product Specification

Revision 4.3



CONTENTS

| | | |
|----------|--|-----------|
| 1 | REVISION HISTORY | 5 |
| 2 | PURPOSE AND SCOPE | 6 |
| 3 | PRODUCT OVERVIEW | 7 |
| 3.1 | MPU-9150 OVERVIEW | 7 |
| 4 | APPLICATIONS..... | 8 |
| 5 | FEATURES | 9 |
| 5.1 | GYROSCOPE FEATURES..... | 9 |
| 5.2 | ACCELEROMETER FEATURES | 9 |
| 5.3 | MAGNETOMETER FEATURES..... | 9 |
| 5.4 | ADDITIONAL FEATURES | 9 |
| 5.5 | MOTIONPROCESSING..... | 10 |
| 5.6 | CLOCKING | 10 |
| 6 | ELECTRICAL CHARACTERISTICS | 11 |
| 6.1 | GYROSCOPE SPECIFICATIONS | 11 |
| 6.2 | ACCELEROMETER SPECIFICATIONS..... | 12 |
| 6.3 | MAGNETOMETER SPECIFICATIONS..... | 13 |
| 6.4 | ELECTRICAL AND OTHER COMMON SPECIFICATIONS..... | 14 |
| 6.5 | ELECTRICAL SPECIFICATIONS, CONTINUED | 15 |
| 6.6 | ELECTRICAL SPECIFICATIONS, CONTINUED | 16 |
| 6.7 | ELECTRICAL SPECIFICATIONS, CONTINUED | 17 |
| 6.8 | I ² C TIMING CHARACTERIZATION..... | 18 |
| 6.9 | ABSOLUTE MAXIMUM RATINGS | 19 |
| 7 | APPLICATIONS INFORMATION | 20 |
| 7.1 | PIN OUT AND SIGNAL DESCRIPTION..... | 20 |
| 7.2 | TYPICAL OPERATING CIRCUIT..... | 21 |
| 7.3 | BILL OF MATERIALS FOR EXTERNAL COMPONENTS | 21 |
| 7.4 | RECOMMENDED POWER-ON PROCEDURE | 22 |
| 7.5 | BLOCK DIAGRAM | 23 |
| 7.6 | OVERVIEW | 23 |
| 7.7 | THREE-AXIS MEMS GYROSCOPE WITH 16-BIT ADCS AND SIGNAL CONDITIONING..... | 24 |
| 7.8 | THREE-AXIS MEMS ACCELEROMETER WITH 16-BIT ADCS AND SIGNAL CONDITIONING | 24 |
| 7.9 | THREE-AXIS MEMS MAGNETOMETER WITH 13-BIT ADCS AND SIGNAL CONDITIONING | 24 |



- 7.10 DIGITAL MOTION PROCESSOR24
- 7.11 PRIMARY I²C24
- 7.12 AUXILIARY I²C SERIAL INTERFACE25
- 7.13 SELF-TEST25
- 7.14 MPU-9150 SOLUTION FOR 10-AXIS SENSOR FUSION USING I²C INTERFACE26
- 7.15 PROCEDURE FOR DIRECTLY ACCESSING THE AK8975 3-AXIS COMPASS28
- 7.16 INTERNAL CLOCK GENERATION28
- 7.17 SENSOR DATA REGISTERS29
- 7.18 FIFO29
- 7.19 INTERRUPTS29
- 7.20 DIGITAL-OUTPUT TEMPERATURE SENSOR29
- 7.21 BIAS AND LDO30
- 7.22 CHARGE PUMP30
- 8 PROGRAMMABLE INTERRUPTS.....31**
- 9 DIGITAL INTERFACE32**
 - 9.1 I²C SERIAL INTERFACE32
 - 9.2 I²C INTERFACE32
 - 9.3 I²C COMMUNICATIONS PROTOCOL32
 - 9.4 I²C TERMS35
- 10 SERIAL INTERFACE CONSIDERATIONS.....36**
 - 10.1 MPU-9150 SUPPORTED INTERFACES36
 - 10.2 LOGIC LEVELS36
 - 10.3 LOGIC LEVELS DIAGRAM37
- 11 ASSEMBLY38**
 - 11.1 ORIENTATION OF AXES38
 - 11.2 PACKAGE DIMENSIONS39
 - 11.3 PCB DESIGN GUIDELINES:40
 - 11.4 ASSEMBLY PRECAUTIONS41
 - 11.5 REFLOW SPECIFICATION43
 - 11.6 STORAGE SPECIFICATIONS44
 - 11.7 PACKAGE MARKING SPECIFICATION44
 - 11.8 TAPE & REEL SPECIFICATION45
 - 11.9 LABEL46
 - 11.10 PACKAGING47



MPU-9150 Product Specification

Document Number: PS-MPU-9150A-00
Revision: 4.3
Release Date: 9/18/2013

11.11 REPRESENTATIVE SHIPPING CARTON LABEL.....48

12 RELIABILITY49

12.1 QUALIFICATION TEST POLICY49

12.2 QUALIFICATION TEST PLAN49

13 ENVIRONMENTAL COMPLIANCE.....50



1 Revision History

| Revision Date | Revision | Description |
|---------------|----------|---|
| 05/27/2011 | 1.0 | Initial Release of Product Specification |
| 06/14/2011 | 2.0 | Modified for Rev C Silicon (sections 5.2, 6.2, 6.4, 6.6, 8.2, 8.3, 8.4) Edits for clarity (several sections) |
| 10/21/2011 | 2.1 | Updated Supply current vs. operating modes (sections 5.3, 5.4, 6.4) Modified Self-Test Response of Accelerometers (section 6.2) Modified absolute maximum rating for acceleration (section 6.9) Updated latch up current rating (sections 6.9, 12.2) Modified package dimensions and PCB design guidelines (sections 11.2, 11.3) Updated assembly precautions (section 11.4) Updated qualification test plan (section 12.2) Edits for clarity (several sections) |
| 10/24/2011 | 3.0 | Modified for Rev D Silicon (sections 6.2, 8.2, 8.3, 8.4) Edits for Clarity (several sections) |
| 12/23/2011 | 3.1 | Updated package dimensions (section 11.2) |
| 05/14/2012 | 4.0 | Added Gyroscope specifications (section 6.1) Added Accelerometer specifications (section 6.2) Updated Electrical Other Common Specifications (section 6.3) Updated latch-up information (section 6.9) Updated Block Diagram (section 7.5) Update Self-Test description (section 7.13) Updated PCB design guidelines (section 11.3) Updated packing and shipping information (sections 11.8, 11.9, 11.10, 11.11) Updated reliability references (section 12.2) |
| 8/28/2013 | 4.1 | Removed "Advanced Information" watermark. Updated section 2.0, 6.5, 6.7, 1.7, 7.2, 7.15, 8, 10.3 and 11.8. Removed section 8.1. |
| 9/13/2013 | 4.2 | Updated Section 6. |
| 9/18/2013 | 4.3 | Updated Section 5.5 & 8. |



2 Purpose and Scope

This product specification provides information regarding the electrical specification and design related information for the MPU-9150™ Motion Processing Unit™ or MPU™.

Electrical characteristics are based upon design analysis and simulation results only. Specifications are subject to change without notice. For references to register map and descriptions of individual registers, please refer to the MPU-9150 Register Map and Register Descriptions document.

3 Product Overview

3.1 MPU-9150 Overview

MotionInterface™ is becoming a “must-have” function being adopted by smartphone and tablet manufacturers due to the enormous value it adds to the end user experience. In smartphones, it finds use in applications such as gesture commands for applications and phone control, enhanced gaming, augmented reality, panoramic photo capture and viewing, and pedestrian and vehicle navigation. With its ability to precisely and accurately track user motions, MotionTracking technology can convert handsets and tablets into powerful 3D intelligent devices that can be used in applications ranging from health and fitness monitoring to location-based services. Key requirements for MotionInterface enabled devices are small package size, low power consumption, high accuracy and repeatability, high shock tolerance, and application specific performance programmability – all at a low consumer price point.

The MPU-9150 is the world’s first integrated 9-axis MotionTracking device that combines a 3-axis MEMS gyroscope, a 3-axis MEMS accelerometer, a 3-axis MEMS magnetometer and a Digital Motion Processor™ (DMP™) hardware accelerator engine. The MPU-9150 is an ideal solution for handset and tablet applications, game controllers, motion pointer remote controls, and other consumer devices. The MPU-9150’s 9-axis MotionFusion combines acceleration and rotational motion plus heading information into a single data stream for the application. This MotionProcessing™ technology integration provides a smaller footprint and has inherent cost advantages compared to discrete gyroscope, accelerometer, plus magnetometer solutions. The MPU-9150 is also designed to interface with multiple non-inertial digital sensors, such as pressure sensors, on its auxiliary I²C port to produce a 10-Axis sensor fusion output. The MPU-9150 is a 3rd generation motion processor and is footprint compatible with the MPU-60X0 and MPU-30X0 families.

The MPU-9150 features three 16-bit analog-to-digital converters (ADCs) for digitizing the gyroscope outputs, three 16-bit ADCs for digitizing the accelerometer outputs and three 13-bit ADCs for digitizing the magnetometer outputs. For precision tracking of both fast and slow motions, the parts feature a user-programmable gyroscope full-scale range of ± 250 , ± 500 , ± 1000 , and $\pm 2000^\circ/\text{sec}$ (dps), a user-programmable accelerometer full-scale range of $\pm 2g$, $\pm 4g$, $\pm 8g$, and $\pm 16g$, and a magnetometer full-scale range of $\pm 1200\mu\text{T}$.

The MPU-9150 is a multi-chip module (MCM) consisting of two dies integrated into a single LGA package. One die houses the 3-Axis gyroscope and the 3-Axis accelerometer. The other die houses the AK8975 3-Axis magnetometer from Asahi Kasei Microdevices Corporation.

An on-chip 1024 Byte FIFO buffer helps lower system power consumption by allowing the system processor to read the sensor data in bursts and then enter a low-power mode as the MPU collects more data. With all the necessary on-chip processing and sensor components required to support many motion-based use cases, the MPU-9150 uniquely supports a variety of advanced motion-based applications entirely on-chip. The MPU-9150 thus enables low-power MotionProcessing in portable applications with reduced processing requirements for the system processor. By providing an integrated MotionFusion output, the DMP in the MPU-9150 offloads the intensive MotionProcessing computation requirements from the system processor, minimizing the need for frequent polling of the motion sensor output.

Communication with all registers of the device is performed using I²C at 400 kHz. Additional features include an embedded temperature sensor and an on-chip oscillator with $\pm 1\%$ variation over the operating temperature range.

By leveraging its patented and volume-proven Nasiri-Fabrication platform, which integrates MEMS wafers with companion CMOS electronics through wafer-level bonding, InvenSense has driven the MPU-9150 package size down to a revolutionary footprint of 4x4x1mm (LGA), while providing the highest performance, lowest noise, and the lowest cost semiconductor packaging required for handheld consumer electronic devices. The part features a robust 10,000g shock tolerance, and has programmable low-pass filters for the gyroscopes, accelerometers, magnetometers, and the on-chip temperature sensor.



4 Applications

- *BlurFree*[™] technology (for Video/Still Image Stabilization)
- *AirSign*[™] technology (for Security/Authentication)
- *TouchAnywhere*[™] technology (for “no touch” UI Application Control/Navigation)
- *MotionCommand*[™] technology (for Gesture Short-cuts)
- Motion-enabled game and application framework
- InstantGesture[™] iG[™] gesture recognition
- Location based services, points of interest, and dead reckoning
- Handset and portable gaming
- Motion-based game controllers
- 3D remote controls for Internet connected DTVs and set top boxes, 3D mice
- Wearable sensors for health, fitness and sports
- Toys
- Pedestrian based navigation
- Navigation
- Electronic Compass

5 Features

5.1 Gyroscope Features

The triple-axis MEMS gyroscope in the MPU-9150 includes a wide range of features:

- Digital-output X-, Y-, and Z-Axis angular rate sensors (gyroscopes) with a user-programmable full-scale range of ± 250 , ± 500 , ± 1000 , and $\pm 2000^\circ/\text{sec}$
- External sync signal connected to the FSYNC pin supports image, video and GPS synchronization
- Integrated 16-bit ADCs enable simultaneous sampling of gyros
- Enhanced bias and sensitivity temperature stability reduces the need for user calibration
- Improved low-frequency noise performance
- Digitally-programmable low-pass filter
- Factory calibrated sensitivity scale factor
- User self-test

5.2 Accelerometer Features

The triple-axis MEMS accelerometer in MPU-9150 includes a wide range of features:

- Digital-output 3-Axis accelerometer with a programmable full scale range of $\pm 2g$, $\pm 4g$, $\pm 8g$ and $\pm 16g$
- Integrated 16-bit ADCs enable simultaneous sampling of accelerometers while requiring no external multiplexer
- Orientation detection and signaling
- Tap detection
- User-programmable interrupts
- High-G interrupt
- User self-test

5.3 Magnetometer Features

The triple-axis MEMS magnetometer in MPU-9150 includes a wide range of features:

- 3-axis silicon monolithic Hall-effect magnetic sensor with magnetic concentrator
- Wide dynamic measurement range and high resolution with lower current consumption.
- Output data resolution is 13 bit ($0.3 \mu\text{T}$ per LSB)
- Full scale measurement range is $\pm 1200 \mu\text{T}$
- Self-test function with internal magnetic source to confirm magnetic sensor operation on end products

5.4 Additional Features

The MPU-9150 includes the following additional features:

- 9-Axis MotionFusion via on-chip Digital Motion Processor (DMP)
- Auxiliary master I^2C bus for reading data from external sensors (e.g., pressure sensor)
- Flexible VLOGIC reference voltage supports multiple I^2C interface voltages
- Smallest and thinnest package for portable devices: 4x4x1mm LGA
- Minimal cross-axis sensitivity between the accelerometer, gyroscope and magnetometer axes
- 1024 byte FIFO buffer reduces power consumption by allowing host processor to read the data in bursts and then go into a low-power mode as the MPU collects more data
- Digital-output temperature sensor
- User-programmable digital filters for gyroscope, accelerometer, and temp sensor
- 10,000 g shock tolerant



- 400kHz Fast Mode I²C for communicating with all registers
- MEMS structure hermetically sealed and bonded at wafer level
- RoHS and Green compliant

5.5 MotionProcessing

- Internal Digital Motion Processing™ (DMP™) engine supports 3D MotionProcessing and gesture recognition algorithms
- The MPU-9150 collects gyroscope, accelerometer and magnetometer data while synchronizing data sampling at a user defined rate. The total dataset obtained by the MPU-9150 includes 3-Axis gyroscope data, 3-Axis accelerometer data, 3-Axis magnetometer data, and temperature data.
- The FIFO buffers the complete data set, reducing timing requirements on the system processor by allowing the processor burst read the FIFO data. After burst reading the FIFO data, the system processor can save power by entering a low-power sleep mode while the MPU collects more data.
- Programmable interrupt supports features such as gesture recognition, panning, zooming, scrolling, tap detection, and shake detection
- Digitally-programmable low-pass filters.
- Low-power pedometer functionality allows the host processor to sleep while the DMP maintains the step count.

5.6 Clocking

- On-chip timing generator $\pm 1\%$ frequency variation over full temperature range
- Optional external clock inputs of 32.768kHz or 19.2MHz



6 Electrical Characteristics

6.1 Gyroscope Specifications

Typical Operating Circuit of Section 7.2, VDD = 2.375V-3.465V, VLOGIC= 1.8V±5% or VDD, T_A = 25°C

| PARAMETER | CONDITIONS | MIN | TYP | MAX | UNITS | NOTES |
|---|------------------------------|-----|-------|-------|-----------|-------|
| GYROSCOPE SENSITIVITY | | | | | | |
| Full-Scale Range | FS_SEL=0 | | ±250 | | °/s | |
| | FS_SEL=1 | | ±500 | | °/s | |
| | FS_SEL=2 | | ±1000 | | °/s | |
| | FS_SEL=3 | | ±2000 | | °/s | |
| Gyroscope ADC Word Length | | | 16 | | bits | |
| Sensitivity Scale Factor | FS_SEL=0 | | 131 | | LSB/(°/s) | |
| | FS_SEL=1 | | 65.5 | | LSB/(°/s) | |
| | FS_SEL=2 | | 32.8 | | LSB/(°/s) | |
| | FS_SEL=3 | | 16.4 | | LSB/(°/s) | |
| Sensitivity Scale Factor Tolerance | 25°C | -3 | | +3 | % | |
| Sensitivity Scale Factor Variation Over Temperature | -40°C to +85°C | | ±0.04 | | %/°C | |
| Nonlinearity | Best fit straight line; 25°C | | 0.2 | | % | |
| Cross-Axis Sensitivity | | | ±2 | | % | |
| GYROSCOPE ZERO-RATE OUTPUT (ZRO) | | | | | | |
| Initial ZRO Tolerance | Component level (25°C) | | ±20 | | °/s | |
| ZRO Variation Over Temperature | -40°C to +85°C | | ±20 | | °/s | |
| GYROSCOPE NOISE PERFORMANCE | FS_SEL=0 | | | | | |
| Total RMS Noise | DLPCFG=2 (92Hz) | | 0.06 | | °/s-rms | |
| Rate Noise Spectral Density | At 10Hz | | 0.005 | | °/s/√Hz | |
| GYROSCOPE MECHANICAL FREQUENCIES | | | | | | |
| X-Axis | | 30 | 33 | 36 | kHz | |
| Y-Axis | | 27 | 30 | 33 | kHz | |
| Z-Axis | | 24 | 27 | 30 | kHz | |
| LOW PASS FILTER RESPONSE | | | | | | |
| | Programmable Range | 5 | | 256 | Hz | |
| OUTPUT DATA RATE | | | | | | |
| | Programmable | 4 | | 8,000 | Hz | |
| GYROSCOPE START-UP TIME | | | | | | |
| ZRO Settling | DLPCFG=0 to ±1% of Final | | 30 | | ms | |



6.2 Accelerometer Specifications

Typical Operating Circuit of Section 7.2, VDD = 2.375V-3.465V, VLOGIC= 1.8V±5% or VDD, T_A = 25°C

| PARAMETER | CONDITIONS | MIN | TYP | MAX | UNITS | NOTES |
|--|---|-----|--------|-------|--------|-------|
| ACCELEROMETER SENSITIVITY | | | | | | |
| Full-Scale Range | AFS_SEL=0 | | ±2 | | g | |
| | AFS_SEL=1 | | ±4 | | g | |
| | AFS_SEL=2 | | ±8 | | g | |
| | AFS_SEL=3 | | ±16 | | g | |
| ADC Word Length | Output in two's complement format | | 16 | | bits | |
| Sensitivity Scale Factor | AFS_SEL=0 | | 16,384 | | LSB/g | |
| | AFS_SEL=1 | | 8,192 | | LSB/g | |
| | AFS_SEL=2 | | 4,096 | | LSB/g | |
| | AFS_SEL=3 | | 2,048 | | LSB/g | |
| Initial Calibration Tolerance | | | ±3 | | % | |
| Sensitivity Change vs. Temperature | AFS_SEL=0, -40°C to +85°C | | ±0.02 | | %/°C | |
| Nonlinearity | Best Fit Straight Line | | 0.5 | | % | |
| ZERO-G OUTPUT | | | | | | |
| Initial Calibration Tolerance | X and Y axes | | ±80 | | mg | |
| | Z axis | | ±150 | | mg | |
| Change over specified temperature – Component level -25°C to 85°C | X & Y Axis | | ±0.75 | | mg/°C | |
| | Z Axis | | ±1.50 | | mg/°C | |
| NOISE PERFORMANCE | | | | | | |
| Power Spectral Density | X, Y & Z Axes, @10Hz, AFS_SEL=0 & ODR=1kHz | | 400 | | μg/√Hz | |
| Total RMS Noise | AFS = 0 @100Hz | | 4 | | mg-rms | |
| LOW PASS FILTER RESPONSE | | | | | | |
| | Programmable Range | 5 | | 260 | Hz | |
| OUTPUT DATA RATE | | | | | | |
| | Programmable Range | 4 | | 1,000 | Hz | |
| INTELLIGENCE FUNCTION INCREMENT | | | 32 | | mg/LSB | |



6.3 Magnetometer Specifications

Typical Operating Circuit of Section 7.2, VDD = 2.375V-3.465V, VLOGIC= 1.8V±5% or VDD, T_A = 25°C

The information in the following table is from the AKM AK8975 datasheet.

| PARAMETER | CONDITIONS | MIN | TYP | MAX | UNITS | NOTES |
|---------------------------------|-----------------------------------|-------|-------|-------|---------|-------|
| MAGNETOMETER SENSITIVITY | | | | | | |
| Full-Scale Range | | | ±1200 | | μT | |
| ADC Word Length | Output in two's complement format | | 13 | | bits | |
| Sensitivity Scale Factor | | 0.285 | 0.3 | 0.315 | μT /LSB | |
| ZERO-FIELD OUTPUT | | | | | | |
| Initial Calibration Tolerance | | -1000 | | 1000 | LSB | |



MPU-9150 Product Specification

Document Number: PS-MPU-9150A-00
Revision: 4.3
Release Date: 9/18/2013

6.4 Electrical and Other Common Specifications

Typical Operating Circuit of Section 7.2, VDD = 2.375V-3.465V, VLOGIC= 1.8V±5% or VDD, T_A = 25°C

| PARAMETER | CONDITIONS | MIN | TYP | MAX | Units | Notes |
|--------------------------------------|---|-------|--|-------|----------------------|-------|
| TEMPERATURE SENSOR | | | | | | |
| Range | | | -40 to +85 | | °C | |
| Sensitivity | Untrimmed | | 340 | | LSB/°C | |
| Temperature Offset | 35°C | | -521 | | LSB | |
| Linearity | Best fit straight line (-40°C to +85°C) | | ±1 | | °C | |
| VDD POWER SUPPLY | | | | | | |
| Operating Voltages | | 2.375 | | 3.465 | V | |
| Power Supply Ramp Rate | Monotonic ramp. Ramp rate is 10% to 90% of the final value | | | 100 | ms | |
| OPERATING CURRENT | | | | | | |
| Normal Operating Current | Gyro at all rates | | Gyro + Accel (Magnetometer and DMP disabled) | 3.9 | mA | |
| | Accel at 1kHz sample rate | | Accel + Magnetometer (Gyro and DMP disabled) | 900 | µA | |
| | Magnetometer at 8Hz repetition rate | | Magnetometer only (DMP, Gyro, and Accel disabled) | 350 | µA | |
| Accelerometer Low Power Mode Current | 1.25 Hz update rate 5 Hz update rate 20 Hz update rate 40 Hz update rate | | 10 20 70 140 | | µA µA µA µA | |
| Magnetometer Full Power Mode Current | 100% Duty Cycle | | 6 | | mA | |
| Full-Chip Idle Mode Supply Current | | | 6 | | µA | |
| VLOGIC REFERENCE VOLTAGE | | | | | | |
| Voltage Range | VLOGIC must be ≤VDD at all times | 1.71 | | VDD | V | |
| Power Supply Ramp Rate | Monotonic ramp. Ramp rate is 10% to 90% of the final value | | | 3 | ms | |
| Normal Operating Current | | | 100 | | µA | |
| TEMPERATURE RANGE | | | | | | |
| Specified Temperature Range | Performance parameters are not applicable beyond Specified Temperature Range | -40 | | +85 | °C | |



6.5 Electrical Specifications, Continued

Typical Operating Circuit of Section 7.2, VDD = 2.375V-3.465V, VLOGIC= 1.8V±5% or VDD, T_A = 25°C

| PARAMETER | CONDITIONS | MIN | TYP | MAX | Units | Notes |
|---|--|------------|--------------------|-------------------|-------------------------|-------|
| SERIAL INTERFACE I ² C Operating Frequency | All registers, Fast-mode All registers, Standard-mode | | | 400 100 | kHz kHz | |
| | | | | | | |
| I²C ADDRESS | AD0 = 0 AD0 = 1 | | 1101000 1101001 | | | |
| DIGITAL INPUTS (SDA, AD0, SCL, FSYNC, CLKIN) V _{IH} , High Level Input Voltage V _{IL} , Low Level Input Voltage C _i , Input Capacitance | | 0.7*VLOGIC | | 0.3*VLOGIC | V V pF | |
| DIGITAL OUTPUT (INT) V _{OH} , High Level Output Voltage V _{OL1} , LOW-Level Output Voltage V _{OLINT1} , INT Low-Level Output Voltage Output Leakage Current t _{INT} , INT Pulse Width | R _{LOAD} =1MΩ R _{LOAD} =1MΩ OPEN=1, 0.3mA sink Current OPEN=1 LATCH_INT_EN=0 | 0.9*VLOGIC | | 0.1*VLOGIC 0.1 | V V V nA μs | |



6.6 Electrical Specifications, Continued

Typical Operating Circuit of Section 7.2, VDD = 2.375V-3.465V, VLOGIC= 1.8V±5% or VDD, TA = 25°C

| Parameters | Conditions | Typical | Units | Notes |
|--|--------------------------------------|-----------------------------|-------|-------|
| Primary I²C I/O (SCL, SDA) | | | | |
| V _{IL} , LOW-Level Input Voltage | | -0.5V to 0.3*VLOGIC | V | |
| V _{IH} , HIGH-Level Input Voltage | | 0.7*VLOGIC to VLOGIC + 0.5V | V | |
| V _{hys} , Hysteresis | | 0.1*VLOGIC | V | |
| V _{OL1} , LOW-Level Output Voltage | 3mA sink current | 0 to 0.4 | V | |
| I _{OL} , LOW-Level Output Current | V _{OL} = 0.4V | 3 | mA | |
| | V _{OL} = 0.6V | 5 | mA | |
| Output Leakage Current | | 100 | nA | |
| t _{of} , Output Fall Time from V _{IHmax} to V _{ILmax} | C _b bus capacitance in pF | 20+0.1C _b to 250 | ns | |
| C _I , Capacitance for Each I/O pin | | < 10 | pF | |
| Auxiliary I²C I/O (ES_CL, ES_DA) | | | | |
| V _{IL} , LOW-Level Input Voltage | | -0.5 to 0.3*VDD | V | |
| V _{IH} , HIGH-Level Input Voltage | | 0.7*VDD to VDD+0.5V | V | |
| V _{hys} , Hysteresis | | 0.1*VDD | V | |
| V _{OL1} , LOW-Level Output Voltage | 1mA sink current | 0 to 0.4 | V | |
| I _{OL} , LOW-Level Output Current | V _{OL} = 0.4V | 1 | mA | |
| | V _{OL} = 0.6V | 1 | mA | |
| Output Leakage Current | | 100 | nA | |
| t _{of} , Output Fall Time from V _{IHmax} to V _{ILmax} | C _b bus cap. in pF | 20+0.1C _b to 250 | ns | |
| C _I , Capacitance for Each I/O pin | | < 10 | pF | |



MPU-9150 Product Specification

Document Number: PS-MPU-9150A-00
 Revision: 4.3
 Release Date: 9/18/2013

6.7 Electrical Specifications, Continued

Typical Operating Circuit of Section 7.2, VDD = 2.375V-3.465V, VLOGIC= 1.8V±5% or VDD, T_A = 25°C

| Parameters | Conditions | Min | Typical | Max | Units | Notes |
|--------------------------------------|---|-----|------------|------|-------|-------|
| INTERNAL CLOCK SOURCE | | | | | | |
| Gyroscope Sample Rate, Fast | CLK_SEL=0,1,2,3 DLPFCFG=0 SAMPLERATEDIV = 0 | | 8 | | kHz | |
| Gyroscope Sample Rate, Slow | DLPFCFG=1,2,3,4,5, or 6 SAMPLERATEDIV = 0 | | 1 | | kHz | |
| Accelerometer Sample Rate | | | 1 | | kHz | |
| Clock Frequency Initial Tolerance | CLK_SEL=0, 25°C | -5 | | +5 | % | |
| Frequency Variation over Temperature | CLK_SEL=1,2,3; 25°C | -1 | | +1 | % | |
| | CLK_SEL=0 | | -15 to +10 | | % | |
| PLL Settling Time | CLK_SEL=1,2,3 | | ±1 | | % | |
| | CLK_SEL=1,2,3 | | 1 | | ms | |
| EXTERNAL 32.768kHz CLOCK | | | | | | |
| External Clock Frequency | CLK_SEL=4 | | 32.768 | | kHz | |
| External Clock Allowable Jitter | Cycle-to-cycle rms | | 1 to 2 | | µs | |
| Gyroscope Sample Rate, Fast | DLPFCFG=0 SAMPLERATEDIV = 0 | | 8.192 | | kHz | |
| Gyroscope Sample Rate, Slow | DLPFCFG=1,2,3,4,5, or 6 SAMPLERATEDIV = 0 | | 1.024 | | kHz | |
| Accelerometer Sample Rate | | | 1.024 | | kHz | |
| PLL Settling Time | | | 1 | | ms | |
| EXTERNAL 19.2MHz CLOCK | | | | | | |
| External Clock Frequency | CLK_SEL=5 | | 19.2 | | MHz | |
| Gyroscope Sample Rate | Full programmable range | 3.9 | | 8000 | Hz | |
| Gyroscope Sample Rate, Fast Mode | DLPFCFG=0 SAMPLERATEDIV = 0 | | 8 | | kHz | |
| Gyroscope Sample Rate, Slow Mode | DLPFCFG=1,2,3,4,5, or 6 SAMPLERATEDIV = 0 | | 1 | | kHz | |
| Accelerometer Sample Rate | | | 1 | | kHz | |
| PLL Settling Time | | | 1 | | ms | |

6.8 I²C Timing Characterization

Typical Operating Circuit of Section 7.2, VDD = 2.375V-3.465V, VLOGIC= 1.8V±5% or VDD, T_A = 25°C

| Parameters | Conditions | Min | Typical | Max | Units | Notes |
|---|--|----------------------|---------|-----|-------|-------|
| I²C TIMING | | | | | | |
| f _{SCL} , SCL Clock Frequency | I ² C FAST-MODE | | | 400 | kHz | |
| t _{HD,STA} , (Repeated) START Condition Hold Time | | 0.6 | | | µs | |
| t _{LOW} , SCL Low Period | | 1.3 | | | µs | |
| t _{HIGH} , SCL High Period | | 0.6 | | | µs | |
| t _{SU,STA} , Repeated START Condition Setup Time | | 0.6 | | | µs | |
| t _{HD,DAT} , SDA Data Hold Time | | 0 | | | µs | |
| t _{SU,DAT} , SDA Data Setup Time | | 100 | | | ns | |
| t _r , SDA and SCL Rise Time | C _b bus cap. from 10 to 400pF | 20+0.1C _b | | 300 | ns | |
| t _f , SDA and SCL Fall Time | C _b bus cap. from 10 to 400pF | 20+0.1C _b | | 300 | ns | |
| t _{SU,STO} , STOP Condition Setup Time | | 0.6 | | | µs | |
| t _{BUF} , Bus Free Time Between STOP and START Condition | | 1.3 | | | µs | |
| C _b , Capacitive Load for each Bus Line | | | < 400 | | pF | |
| t _{VD,DAT} , Data Valid Time | | | | 0.9 | µs | |
| t _{VD,ACK} , Data Valid Acknowledge Time | | | | 0.9 | µs | |

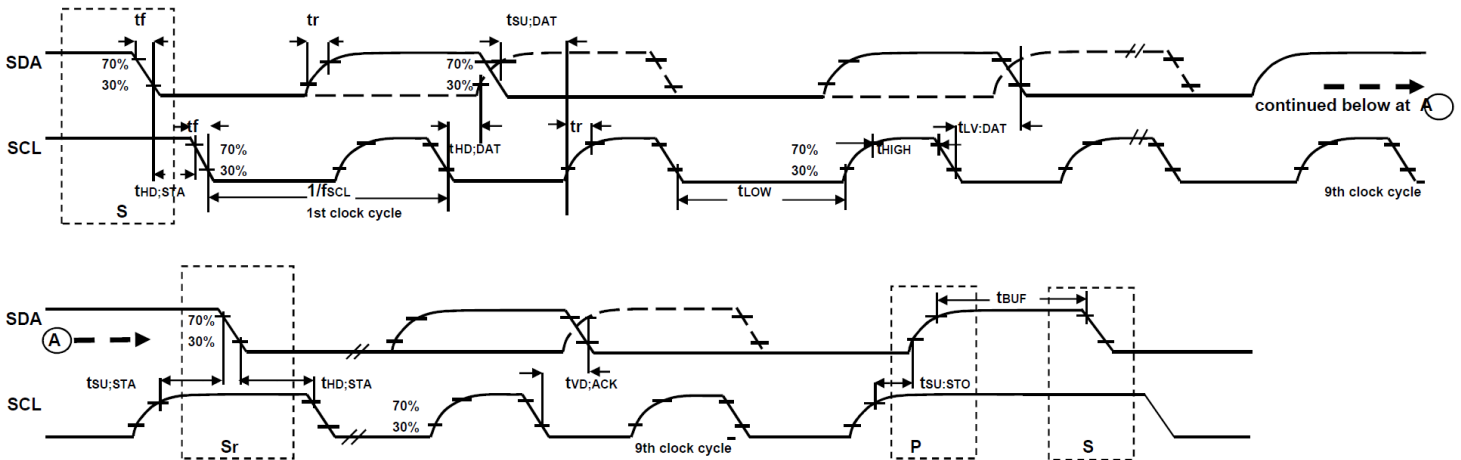

I²C Bus Timing Diagram



6.9 Absolute Maximum Ratings

Stress above those listed as “Absolute Maximum Ratings” may cause permanent damage to the device. These are stress ratings only and functional operation of the device at these conditions is not implied. Exposure to the absolute maximum ratings conditions for extended periods may affect device reliability.

| Parameter | Rating |
|--|-------------------------------------|
| Supply Voltage, VDD | -0.5V to +6V |
| VLOGIC Input Voltage Level | -0.5V to VDD + 0.5V |
| REGOUT | -0.5V to 2V |
| Input Voltage Level (CLKIN, AUX_DA, AD0, FSYNC, INT, SCL, SDA) | -0.5V to VDD + 0.5V |
| CPOUT (2.5V ≤ VDD ≤ 3.6V) | -0.5V to 30V |
| Acceleration (Any Axis, unpowered) | 10,000g for 0.2ms |
| Operating Temperature Range | -40°C to +85°C |
| Storage Temperature Range | -40°C to +125°C |
| Electrostatic Discharge (ESD) Protection | 2kV (HBM); 250V (MM) |
| Latch-up | JEDEC Class II (2), 125°C ±100mA |

7 Applications Information

7.1 Pin Out and Signal Description

| Pin Number | Pin Name | Pin Description |
|-------------------------|----------|--|
| 1 | CLKIN | Optional external reference clock input. Connect to GND if unused. |
| 6 | ES_DA | Auxiliary I ² C master serial data |
| 7 | ES_CL | Auxiliary I ² C Master serial clock |
| 8 | VLOGIC | Digital I/O supply voltage |
| 9 | AD0 | I ² C Slave Address LSB (AD0) |
| 10 | REGOUT | Regulator filter capacitor connection |
| 11 | FSYNC | Frame synchronization digital input. Connect to GND if unused. |
| 12 | INT | Interrupt digital output (totem pole or open-drain) |
| 3, 13 | VDD | Power supply voltage and Digital I/O supply voltage |
| 15, 17, 18 | GND | Power supply ground |
| 20 | CPOUT | Charge pump capacitor connection |
| 22 | RESV | Reserved. Do not connect |
| 23 | SCL | I ² C serial clock (SCL) |
| 24 | SDA | I ² C serial data (SDA) |
| 2, 4, 5, 14, 16, 19, 21 | RESV | Reserved. Do not connect. |

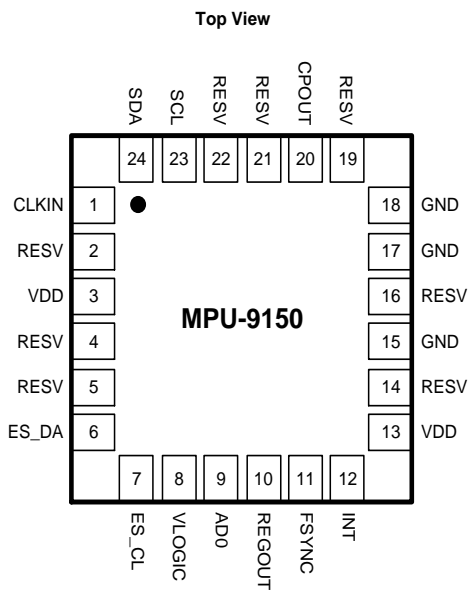

LGA Package
 24-pin, 4mm x 4mm x 1mm

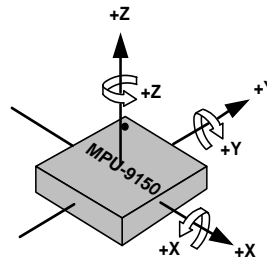

Orientation of Axes of Sensitivity and
 Polarity of Rotation for Accel & Gyro

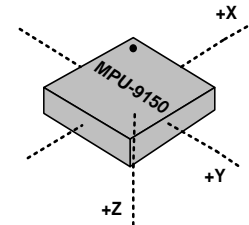

Orientation of Axes of Sensitivity for
 Magnetometer

7.2 Typical Operating Circuit

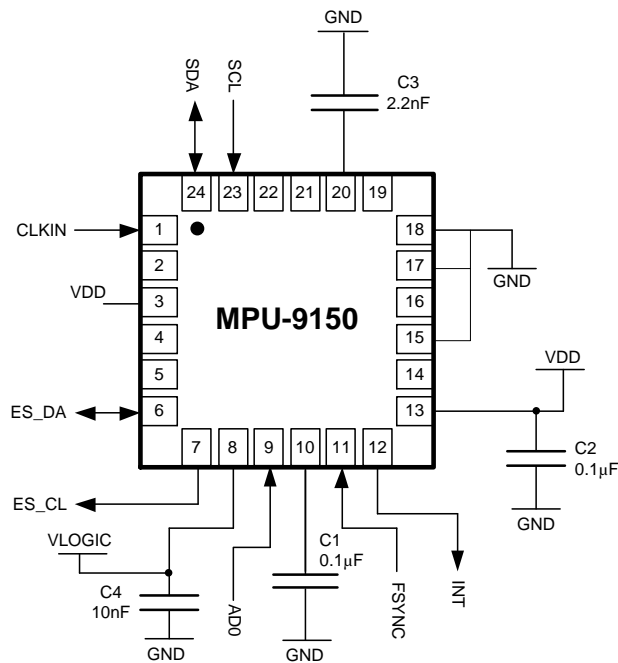

Typical Operating Circuit

7.3 Bill of Materials for External Components

| Component | Label | Specification | Quantity |
|-------------------------------------|-------|-------------------------------|----------|
| Regulator Filter Capacitor (Pin 10) | C1 | Ceramic, X7R, 0.1µF ±10%, 2V | 1 |
| VDD Bypass Capacitor (Pin 13) | C2 | Ceramic, X7R, 0.1µF ±10%, 4V | 1 |
| Charge Pump Capacitor (Pin 20) | C3 | Ceramic, X7R, 2.2nF ±10%, 50V | 1 |
| VLOGIC Bypass Capacitor (Pin 8) | C4* | Ceramic, X7R, 10nF ±10%, 4V | 1 |

7.4 Recommended Power-on Procedure

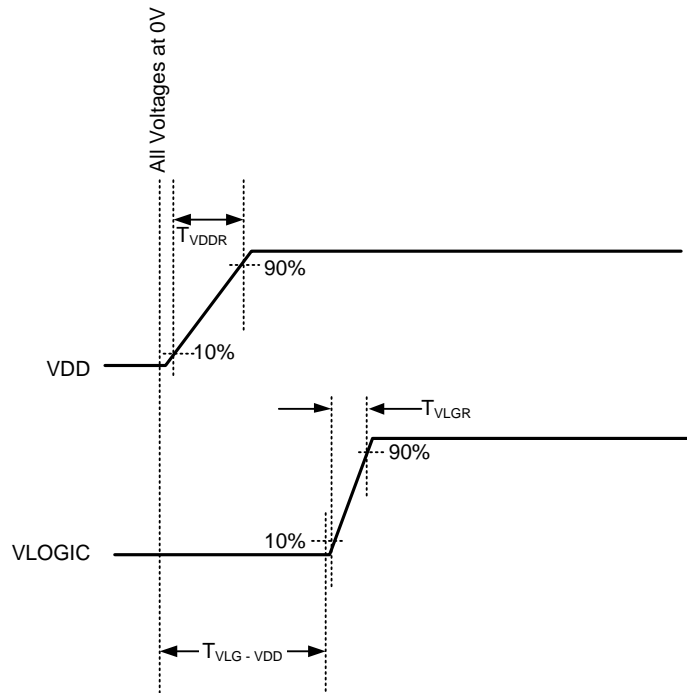

Power-Up Sequencing

1. VLOGIC amplitude must always be $\leq VDD$ amplitude
2. T_{VDDR} is VDD rise time: Time for VDD to rise from 10% to 90% of its final value
3. T_{VDDR} is $\leq 100\text{msec}$
4. T_{VLGR} is VLOGIC rise time: Time for VLOGIC to rise from 10% to 90% of its final value
5. T_{VLGR} is $\leq 3\text{msec}$
6. $T_{VLG-VDD}$ is the delay from the start of VDD ramp to the start of VLOGIC rise
7. $T_{VLG-VDD}$ is $\geq 0\text{ms}$;
8. VDD and VLOGIC must be monotonic ramps

7.5 Block Diagram

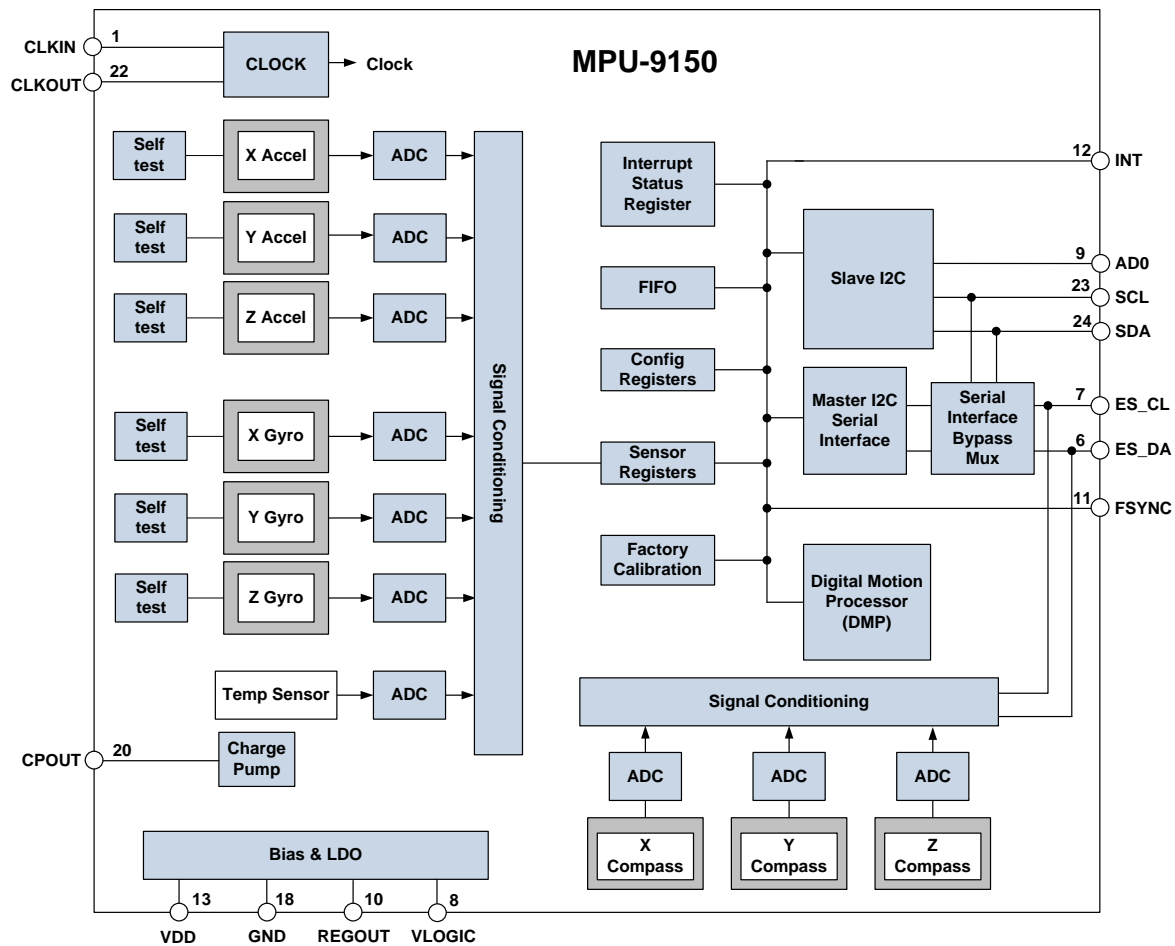

7.6 Overview

The MPU-9150 is comprised of the following key blocks and functions:

- Three-axis MEMS rate gyroscope sensor with 16-bit ADCs and signal conditioning
- Three-axis MEMS accelerometer sensor with 16-bit ADCs and signal conditioning
- Three-axis MEMS magnetometer sensor with 13-bit ADCs and signal conditioning
- Digital Motion Processor (DMP) engine
- Primary I²C serial communications interface
- Auxiliary I²C serial interface for 3rd party sensors
- Clocking
- Sensor Data Registers
- FIFO
- Interrupts
- Digital-Output Temperature Sensor
- Gyroscope, Accelerometer and Magnetometer Self-test
- Bias and LDO
- Charge Pump



7.7 Three-Axis MEMS Gyroscope with 16-bit ADCs and Signal Conditioning

The MPU-9150 includes a 3-Axis vibratory MEMS rate gyroscope, which detect rotations about the X-, Y-, and Z- Axes. When the gyro is are rotated about any of the sense axes, the Coriolis Effect causes a vibration that is detected by a capacitive pickoff. The resulting signal is amplified, demodulated, and filtered to produce a voltage that is proportional to the angular rate. This voltage is digitized using individual on-chip 16-bit Analog-to-Digital Converters (ADCs) to sample each axis. The full-scale range of the gyro sensor may be digitally programmed to ± 250 , ± 500 , ± 1000 , or ± 2000 degrees per second (dps). The ADC sample rate is programmable from 8,000 samples per second, down to 3.9 samples per second, and user-selectable low-pass filters enable a wide range of cut-off frequencies.

7.8 Three-Axis MEMS Accelerometer with 16-bit ADCs and Signal Conditioning

The MPU-9150's 3-axis accelerometer uses separate proof masses for each axis. Acceleration along a particular axis induces displacement on the corresponding proof mass, and capacitive sensors detect the displacement differentially. The MPU-9150's architecture reduces the accelerometer's susceptibility to fabrication variations as well as to thermal drift. When the device is placed on a flat surface, it will measure 0g on the X- and Y-axes and +1g on the Z-axis. The accelerometer's scale factor is calibrated at the factory and is nominally independent of supply voltage. Each sensor has a dedicated sigma-delta ADC for providing digital outputs. The full scale range of the digital output can be adjusted to $\pm 2g$, $\pm 4g$, $\pm 8g$, or $\pm 16g$.

7.9 Three-Axis MEMS Magnetometer with 13-bit ADCs and Signal Conditioning

The 3-axis magnetometer uses highly sensitive Hall sensor technology. The compass portion of the IC incorporates magnetic sensors for detecting terrestrial magnetism in the X-, Y-, and Z- Axes, a sensor driving circuit, a signal amplifier chain, and an arithmetic circuit for processing the signal from each sensor. Each ADC has a 13-bit resolution and a full scale range of $\pm 1200 \mu\text{T}$.

7.10 Digital Motion Processor

The embedded Digital Motion Processor (DMP) is located within the MPU-9150 and offloads computation of motion processing algorithms from the host processor. The DMP acquires data from accelerometers, gyroscopes, magnetometers and additional 3rd party sensors such as pressure sensors, and processes the data. The resulting data can be read from the DMP's registers, or can be buffered in a FIFO. The DMP has access to one of the MPU's external pins, which can be used for generating interrupts.

The purpose of the DMP is to offload both timing requirements and processing power from the host processor. Typically, motion processing algorithms should be run at a high rate, often around 200Hz, in order to provide accurate results with low latency. This is required even if the application updates at a much lower rate; for example, a low power user interface may update as slowly as 5Hz, but the motion processing should still run at 200Hz. The DMP can be used as a tool in order to minimize power, simplify timing, simplify the software architecture, and save valuable MIPS on the host processor for use in the application.

7.11 Primary I²C

The MPU-9150 communicates to a system processor using an I²C serial interface. The MPU-9150 always acts as a slave when communicating to the system processor. The logic level for communications to the master is set by the voltage on the VLOGIC pin. The LSB of the of the I²C slave address is set by pin 9 (AD0).

7.12 Auxiliary I²C Serial Interface

The MPU-9150 has an auxiliary I²C bus for communicating to off-chip sensors. This bus has two operating modes:

- I²C Master Mode: The MPU-9150 acts as a master to any external sensors connected to the auxiliary I²C bus
- Pass-Through Mode: The MPU-9150 directly connects the primary and auxiliary I²C buses together, allowing the system processor to directly communicate with any external sensors.

Auxiliary I²C Bus Modes of Operation:

- I²C Master Mode: Allows the MPU-9150 to directly access the data registers of external digital sensors, such as a pressure sensor. In this mode, the MPU-9150 directly obtains data from auxiliary sensors, allowing the on-chip DMP to generate sensor fusion data without intervention from the system applications processor.

For example, In I²C Master mode, the MPU-9150 can be configured to perform burst reads, returning the following data from a triple-Axis external sensor:

- X-Axis data (2 bytes)
 - Y-Axis data (2 bytes)
 - Z-Axis data (2 bytes)
- The I²C Master can be configured to read up to 24 bytes from up to 3 auxiliary sensors. A fourth sensor can be configured to work single byte read/write mode.
 - Pass-Through Mode: Allows an external system processor to act as master and directly communicate to the external sensors connected to the auxiliary I²C bus pins (ES_DA and ESCL). In this mode, the auxiliary I²C bus control logic (3rd-party sensor interface block) of the MPU-9150 is disabled, and the auxiliary I²C pins ES_DA and ES_CL (Pins 6 and 7) are connected to the main I²C bus (Pins 23 and 24) through analog switches.

Pass-Through Mode is useful for configuring the external sensor, or for keeping the MPU-9150 in a low-power mode when only the external sensors are used. In Pass-Through Mode the system processor can still access MPU-9150 data through the I²C interface.

Auxiliary I²C Bus IO Logic Level

The logic level of the auxiliary I²C bus is VDD.

For further information regarding the MPU-9150's logic level, please refer to Section 10.2.

7.13 Self-Test

Please refer to the MPU-9150 self-test applications note and MPU-9150 register map for more details on self-test.

Self-test allows for the testing of the mechanical and electrical portions of the sensors. The self-test for each measurement axis can be activated by controlling the bits of the Gyro and Accel control registers.

When self-test is activated, the electronics cause the sensors to be actuated and produce an output signal. The output signal is used to observe the self-test response.

The self-test response is defined as follows:

Self-test response = Sensor output with self-test enabled – Sensor output without self-test enabled



The self-test response for each accelerometer axis is defined in the accelerometer specification table (Section 6.2), while that for each gyroscope axis is defined in the gyroscope specification table (Section 6.1).

When the value of the self-test response is within the min/max limits of the product specification, the part has passed self-test. When the self-test response exceeds the min/max values, the part is deemed to have failed self-test. Code for operating self-test code is included within the MotionApps software provided by InvenSense.

7.14 MPU-9150 Solution for 10-Axis Sensor Fusion Using I²C Interface

In the figure below, the system processor is an I²C master to the MPU-9150. In addition, the MPU-9150 is an I²C master to the optional external pressure sensor. The MPU-9150 has limited capabilities as an I²C Master, and depends on the system processor to manage the initial configuration of any auxiliary sensors. The MPU-9150 has an interface bypass multiplexer, which connects the system processor I²C bus pins 23 and 24 (SDA and SCL) directly to the auxiliary sensor I²C bus pins 6 and 7 (ES_DA and ES_CL).

Once the auxiliary sensors have been configured by the system processor, the interface bypass multiplexer should be disabled so that the MPU-9150 auxiliary I²C master can take control of the sensor I²C bus and gather data from the auxiliary sensors.

For further information regarding I²C master control, please refer to Section 10.

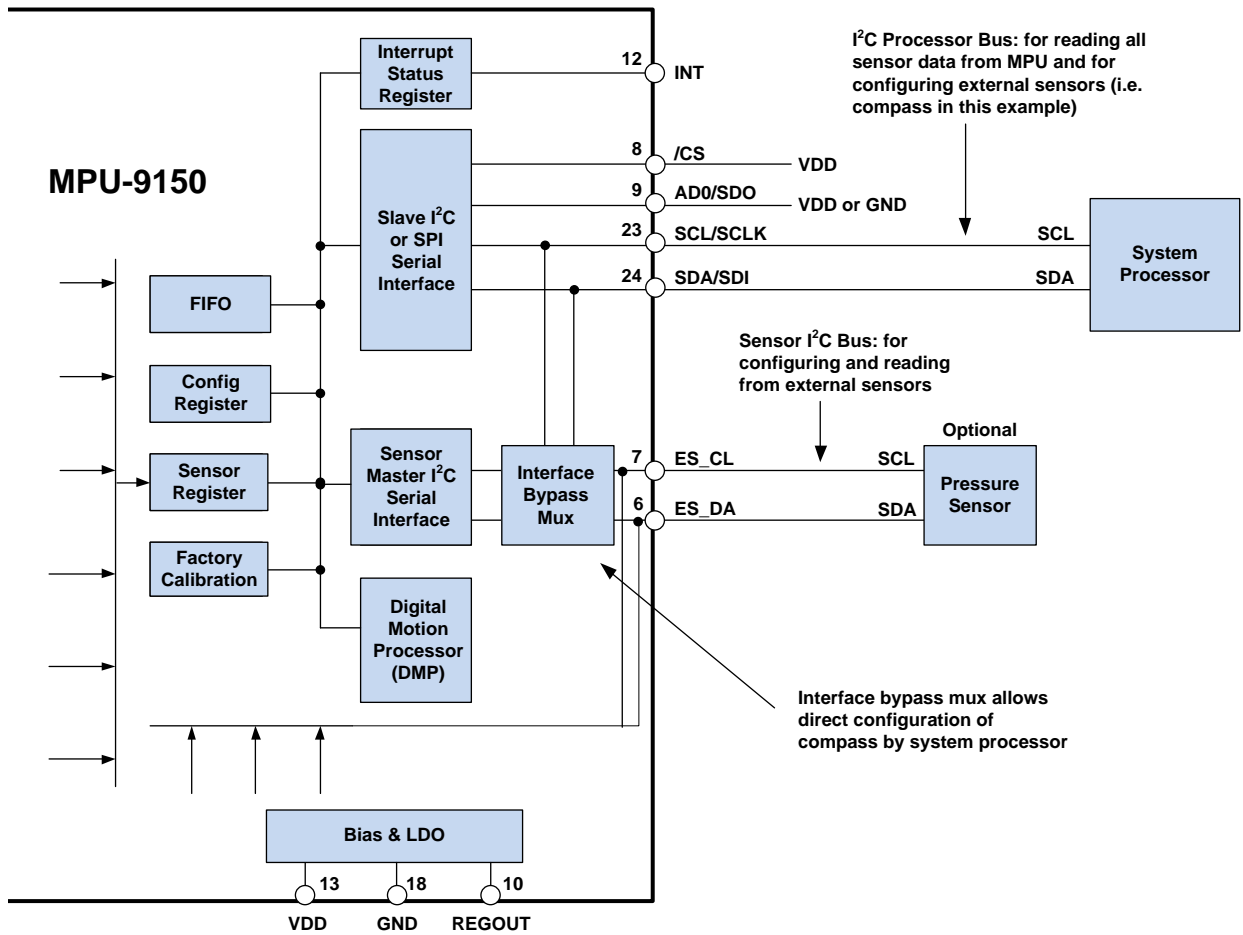

7.15 Procedure for Directly Accessing the AK8975 3-Axis Compass

The AK8975 3-Axis Compass is connected to the MPU-9150 through the MPU's Auxiliary I²C Bus. In order to access this compass directly, the MPU-9150 should be put into Pass-Through Mode.

For further information regarding MPU-9150 Pass-Through Mode, please refer to Section 7.12.

The slave address for AK8975 is 0x0C or 12 decimal.

The MPU-9150 pin configuration for Direct Access to the AK8975 is described in the table below.

Pin Configuration for Direct Access to AK8975 3-Axis Compass

| Pin Number | Pin Name | Pin Description |
|----------------------------|----------|---|
| 1 | CLKIN | Inactive. Connect to GND. |
| 6 | ES_DA | Active. Leave as NC. (provision for option external pull-up resistor to VDD) |
| 7 | ES_CL | Active. Leave as NC. (provision for option external pull-up resistor to VDD) |
| 8 | VLOGIC | Active. Digital I/O supply voltage. |
| 9 | AD0 | Active. Connect to GND. |
| 10 | REGOUT | Active. Connect a 100nF bypass capacitor on the board. |
| 11 | FSYNC | Inactive. Connect to GND. |
| 12 | INT | Inactive. Leave as NC. |
| 3, 13 | VDD | Power supply voltage and Digital I/O supply voltage |
| 15, 17, 18 | GND | Power supply ground. |
| 20 | CPOUT | Active. Connect a 10nF bypass capacitor on the board. |
| 22 | RESV | Reserved. Do not connect. |
| 23 | SCL | Active. I ² C serial clock (SCL) |
| 24 | SDA | Active. I ² C serial data (SDA) |
| 2, 4, 5, 14, 16, 19, 21 | RESV | Reserved. Do not connect. |

For detailed information regarding the Register Map of the AK8975, please refer to the MPU-9150 Register Map and Register Descriptions document.

7.16 Internal Clock Generation

The MPU-9150 has a flexible clocking scheme, allowing a variety of internal or external clock sources to be used for the internal synchronous circuitry. This synchronous circuitry includes the signal conditioning and ADCs, the DMP, and various control circuits and registers. An on-chip PLL provides flexibility in the allowable inputs for generating this clock.

Allowable internal sources for generating the internal clock are:

- An internal relaxation oscillator
- Any of the X, Y, or Z gyros (MEMS oscillators with a variation of ±1% over temperature)

Allowable external clocking sources are:

- 32.768kHz square wave
- 19.2MHz square wave



Selection of the source for generating the internal synchronous clock depends on the availability of external sources and the requirements for power consumption and clock accuracy. These requirements will most likely vary by mode of operation. For example, in one mode, where the biggest concern is power consumption, the user may wish to operate the Digital Motion Processor of the MPU-9150 to process accelerometer data, while keeping the gyros and magnetometer off. In this case, the internal relaxation oscillator is a good clock choice. However, in another mode, where the gyros are active, selecting the gyros as the clock source provides for a more accurate clock source.

Clock accuracy is important, since timing errors directly affect the distance and angle calculations performed by the Digital Motion Processor (and by extension, by any processor).

There are also start-up conditions to consider. When the MPU-9150 first starts up, the device uses its internal clock until programmed to operate from another source. This allows the user, for example, to wait for the MEMS oscillators to stabilize before they are selected as the clock source.

7.17 Sensor Data Registers

The sensor data registers contain the latest gyro, accelerometer, magnetometer, and temperature measurement data. They are read-only registers, and are accessed via the serial interface. Data from these registers may be read anytime. However, the interrupt function may be used to determine when new data is available.

For a table of interrupt sources please refer to Section 8.

7.18 FIFO

The MPU-9150 contains a 1024-byte FIFO register that is accessible via the Serial Interface. The FIFO configuration register determines which data is written into the FIFO. Possible choices include gyro data, accelerometer data, temperature readings, auxiliary sensor readings, and FSYNC input. A FIFO counter keeps track of how many bytes of valid data are contained in the FIFO. The FIFO register supports burst reads. The interrupt function may be used to determine when new data is available.

For further information regarding the FIFO, please refer to the MPU-9150 Register Map and Register Descriptions document.

7.19 Interrupts

Interrupt functionality is configured via the Interrupt Configuration register. Items that are configurable include the INT pin configuration, the interrupt latching and clearing method, and triggers for the interrupt. Items that can trigger an interrupt are (1) new data is available to be read (from the FIFO and Data registers); (2) accelerometer event interrupts; and (3) the MPU-9150 did not receive an acknowledge from an auxiliary sensor on the secondary I²C bus. The interrupt status can be read from the Interrupt Status register.

For further information regarding interrupts, please refer to the MPU-9150 Register Map and Register Descriptions document.

For information regarding the MPU-9150's accelerometer event interrupts, please refer to Section 8.

7.20 Digital-Output Temperature Sensor

An on-chip temperature sensor and ADC are used to measure the MPU-9150 die temperature. The readings from the ADC can be read from the FIFO or the Sensor Data registers.



7.21 Bias and LDO

The bias and LDO section generates the internal supply and the reference voltages and currents required by the MPU-9150. Its two inputs are an unregulated VDD and a VLOGIC logic reference supply voltage. The LDO output is bypassed by a capacitor at REGOUT. For further details on the capacitor, please refer to the Bill of Materials for External Components (Section 7.3).

7.22 Charge Pump

An on-board charge pump generates the high voltage required for the MEMS oscillators. Its output is bypassed by a capacitor at CPOUT. For further details on the capacitor, please refer to the Bill of Materials for External Components (Section 7.3).



8 Programmable Interrupts

The MPU-9150 has a programmable interrupt system which can generate an interrupt signal on the INT pin. Status flags indicate the source of an interrupt. Interrupt sources may be enabled and disabled individually.

Table of Interrupt Sources

| Interrupt Name | Module |
|---|-------------------------|
| FIFO Overflow | FIFO |
| Data Ready | Sensor Registers |
| I ² C Master errors: Lost Arbitration, NACKs | I ² C Master |
| I ² C Slave 4 | I ² C Master |

For information regarding the interrupt enable/disable registers and flag registers, please refer to the MPU-9150 Register Map and Register Descriptions document.



9 Digital Interface

9.1 I²C Serial Interface

The internal registers and memory of the MPU-9150 can be accessed using either I²C at 400 kHz.

Serial Interface

| Pin Number | Pin Name | Pin Description |
|------------|----------|---|
| 8 | VLOGIC | Digital I/O supply voltage. VLOGIC must be \leq VDD at all times. |
| 9 | AD0 | I ² C Slave Address LSB |
| 23 | SCL | I ² C serial clock |
| 24 | SDA | I ² C serial data |

9.2 I²C Interface

I²C is a two-wire interface comprised of the signals serial data (SDA) and serial clock (SCL). In general, the lines are open-drain and bi-directional. In a generalized I²C interface implementation, attached devices can be a master or a slave. The master device puts the slave address on the bus, and the slave device with the matching address acknowledges the master.

The MPU-9150 always operates as a slave device when communicating to the system processor, which thus acts as the master. SDA and SCL lines typically need pull-up resistors to VDD. The maximum bus speed is 400 kHz.

The slave address of the MPU-9150 is b110100X which is 7 bits long. The LSB bit of the 7 bit address is determined by the logic level on pin AD0. This allows two MPU-9150s to be connected to the same I²C bus. When used in this configuration, the address of the one of the devices should be b1101000 (pin AD0 is logic low) and the address of the other should be b1101001 (pin AD0 is logic high).

9.3 I²C Communications Protocol

START (S) and STOP (P) Conditions

Communication on the I²C bus starts when the master puts the START condition (S) on the bus, which is defined as a HIGH-to-LOW transition of the SDA line while SCL line is HIGH (see figure below). The bus is considered to be busy until the master puts a STOP condition (P) on the bus, which is defined as a LOW to HIGH transition on the SDA line while SCL is HIGH (see figure below).

Additionally, the bus remains busy if a repeated START (Sr) is generated instead of a STOP condition.

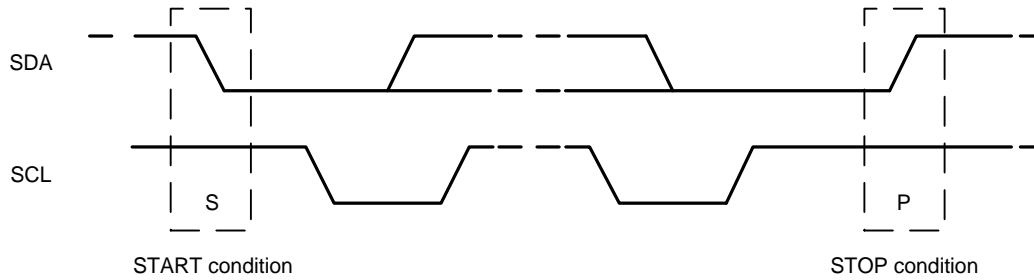

START and STOP Conditions

Data Format / Acknowledge

I²C data bytes are defined to be 8-bits long. There is no restriction to the number of bytes transmitted per data transfer. Each byte transferred must be followed by an acknowledge (ACK) signal. The clock for the acknowledge signal is generated by the master, while the receiver generates the actual acknowledge signal by pulling down SDA and holding it low during the HIGH portion of the acknowledge clock pulse.

If a slave is busy and cannot transmit or receive another byte of data until some other task has been performed, it can hold SCL LOW, thus forcing the master into a wait state. Normal data transfer resumes when the slave is ready, and releases the clock line (refer to the following figure).

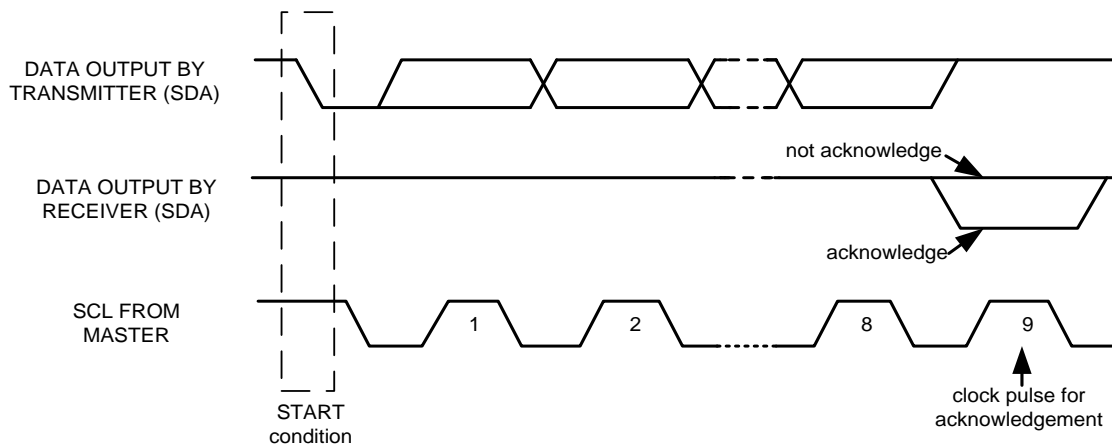

Acknowledge on the I²C Bus

Communications

After beginning communications with the START condition (S), the master sends a 7-bit slave address followed by an 8th bit, the read/write bit. The read/write bit indicates whether the master is receiving data from or is writing to the slave device. Then, the master releases the SDA line and waits for the acknowledge signal (ACK) from the slave device. Each byte transferred must be followed by an acknowledge bit. To acknowledge, the slave device pulls the SDA line LOW and keeps it LOW for the high period of the SCL line. Data transmission is always terminated by the master with a STOP condition (P), thus freeing the communications line. However, the master can generate a repeated START condition (Sr), and address another slave without first generating a STOP condition (P). A LOW to HIGH transition on the SDA line while SCL is HIGH defines the stop condition. All SDA changes should take place when SCL is low, with the exception of start and stop conditions.

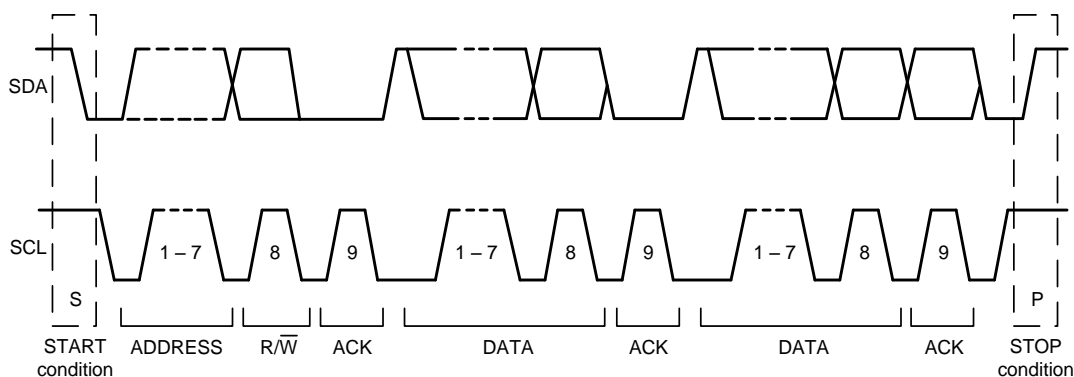

Complete I²C Data Transfer

To write the internal MPU-9150 registers, the master transmits the start condition (S), followed by the I²C address and the write bit (0). At the 9th clock cycle (when the clock is high), the MPU-9150 acknowledges the transfer. Then the master puts the register address (RA) on the bus. After the MPU-9150 acknowledges the reception of the register address, the master puts the register data onto the bus. This is followed by the ACK signal, and data transfer may be concluded by the stop condition (P). To write multiple bytes after the last ACK signal, the master can continue outputting data rather than transmitting a stop signal. In this case, the MPU-9150 automatically increments the register address and loads the data to the appropriate register. The following figures show single and two-byte write sequences.

Single-Byte Write Sequence

| | | | | | | | | |
|--------|---|------|-----|----|-----|------|-----|---|
| Master | S | AD+W | | RA | | DATA | | P |
| Slave | | | ACK | | ACK | | ACK | |

Burst Write Sequence

| | | | | | | | | | | |
|--------|---|------|-----|----|-----|------|-----|------|-----|---|
| Master | S | AD+W | | RA | | DATA | | DATA | | P |
| Slave | | | ACK | | ACK | | ACK | | ACK | |



To read the internal MPU-9150 registers, the master sends a start condition, followed by the I²C address and a write bit, and then the register address that is going to be read. Upon receiving the ACK signal from the MPU-9150, the master transmits a start signal followed by the slave address and read bit. As a result, the MPU-9150 sends an ACK signal and the data. The communication ends with a not acknowledge (NACK) signal and a stop bit from master. The NACK condition is defined such that the SDA line remains high at the 9th clock cycle. The following figures show single and two-byte read sequences.

Single-Byte Read Sequence

| | | | | | | | | | | | |
|--------|---|------|-----|----|-----|---|------|-----|------|------|---|
| Master | S | AD+W | | RA | | S | AD+R | | | NACK | P |
| Slave | | | ACK | | ACK | | | ACK | DATA | | |

Burst Read Sequence

| | | | | | | | | | | | | | |
|--------|---|------|-----|----|-----|---|------|-----|------|-----|------|------|---|
| Master | S | AD+W | | RA | | S | AD+R | | | ACK | | NACK | P |
| Slave | | | ACK | | ACK | | | ACK | DATA | | DATA | | |

9.4 I²C Terms

| Signal | Description |
|--------|--|
| S | Start Condition: SDA goes from high to low while SCL is high |
| AD | Slave I ² C address |
| W | Write bit (0) |
| R | Read bit (1) |
| ACK | Acknowledge: SDA line is low while the SCL line is high at the 9 th clock cycle |
| NACK | Not-Acknowledge: SDA line stays high at the 9 th clock cycle |
| RA | MPU-9150 internal register address |
| DATA | Transmit or received data |
| P | Stop condition: SDA going from low to high while SCL is high |



10 Serial Interface Considerations

10.1 MPU-9150 Supported Interfaces

The MPU-9150 supports I²C communications.

10.2 Logic Levels

The MPU-9150's I/O logic levels are set to be either VDD or VLOGIC, as shown in the table below.

I/O Logic Levels

| MICROPROCESSOR LOGIC LEVELS (Pins: SDA, SCL, AD0, CLKIN, INT) | AUXILIARY LOGIC LEVELS (Pins: ES_DA, ES_CL) |
|---|---|
| VLOGIC | VDD |

VLOGIC may be set to be equal to VDD or to another voltage. However, VLOGIC must be \leq VDD at all times. VLOGIC is the power supply voltage for the microprocessor system bus and VDD is the supply for the auxiliary I²C bus, as shown in the figure of Section 10.3.

10.3 Logic Levels Diagram

The figure below depicts a sample circuit with a third party pressure sensor attached to the auxiliary I²C bus. It shows logic levels and voltage connections. Note: Actual configuration will depend on the auxiliary sensors used.

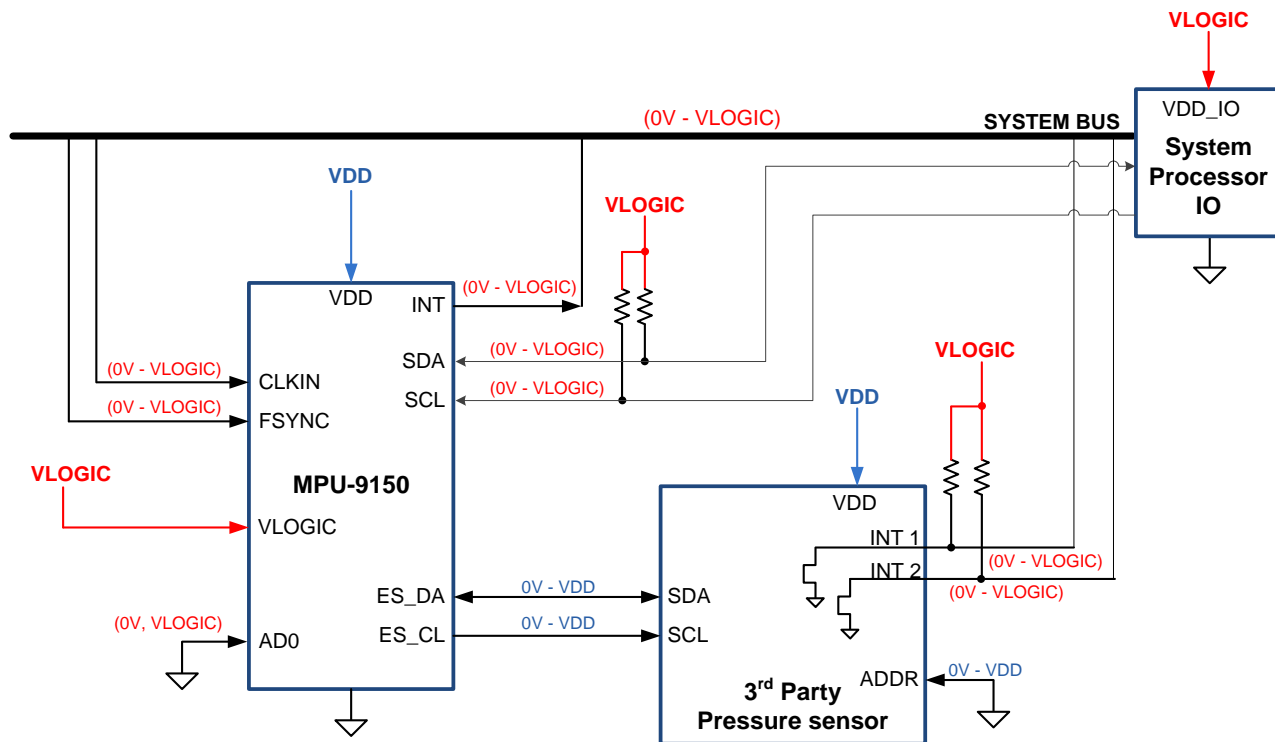

I/O Levels and Connections

Notes:

1. The IO voltage levels of ES_DA and ES_CL are set relative to VDD.
2. Third-party auxiliary device logic levels are referenced to VDD. Setting INT1 and INT2 to open drain configuration provides voltage compatibility when VDD ≠ VLOGIC. When VDD = VLOGIC, INT1 and INT2 may be set to push-pull outputs, and external pull-up resistors are not needed.
3. All other MPU-9150 logic IO is always referenced to VLOGIC.

11 Assembly

This section provides general guidelines for assembling InvenSense Micro Electro-Mechanical Systems (MEMS) gyros packaged in Lead Grid Array package (LGA) surface mount integrated circuits.

11.1 Orientation of Axes

The diagram below shows the orientation of the axes of sensitivity and the polarity of rotation. Note the pin 1 identifier (•) in the figure.

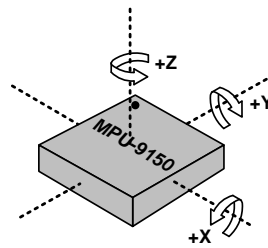

**Orientation of Axes of Sensitivity
and Polarity of Rotation for
Gyroscopes and Accelerometers**

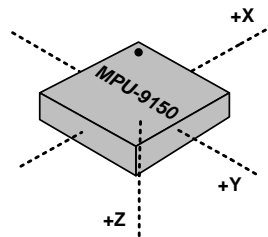

**Orientation of Axes of Sensitivity
for Compass**

11.2 Package Dimensions

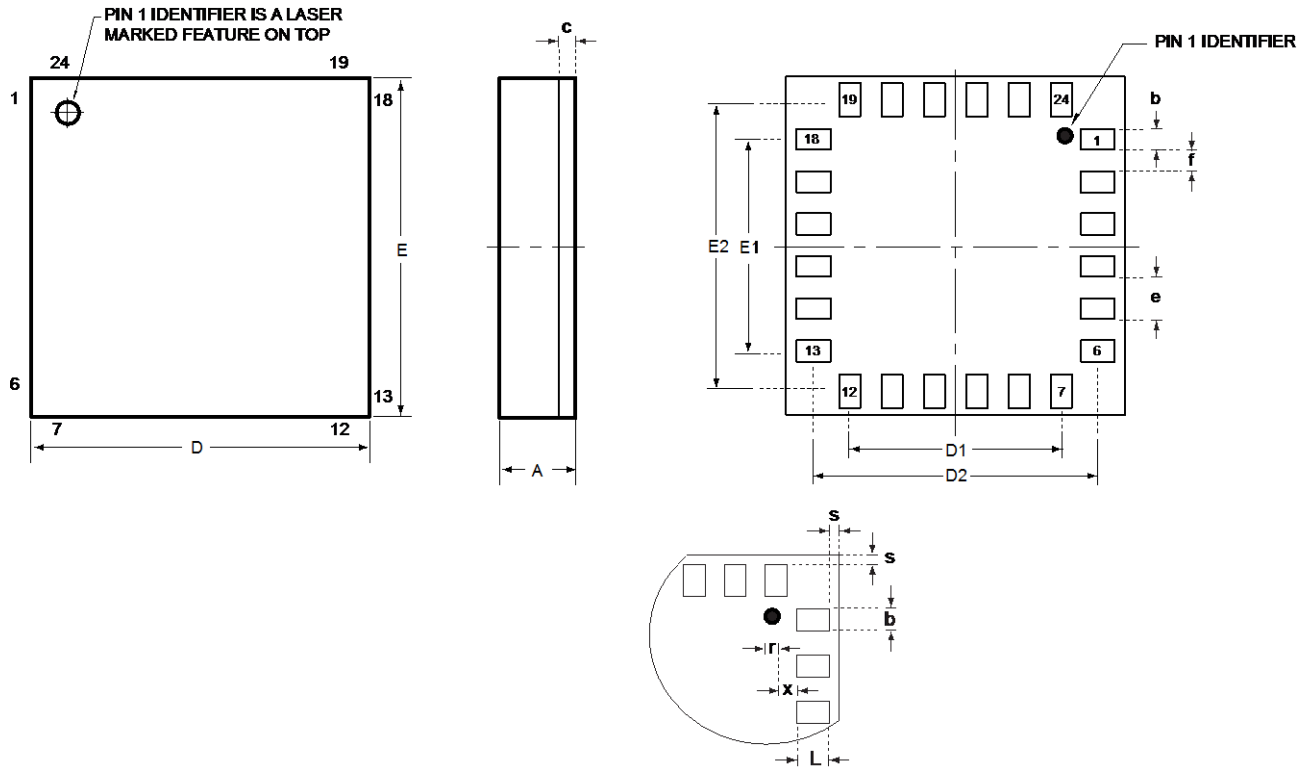

| SYMBOLS | DIMENSIONS IN MILLIMETERS | | |
|---------|---------------------------|-------|-------|
| | MIN. | NOM. | MAX. |
| A | 0.90 | 1.00 | 1.10 |
| c | 0.106 | 0.136 | 0.166 |
| D | 3.90 | 4.00 | 4.10 |
| E | 3.90 | 4.00 | 4.10 |
| D1/E1 | --- | 2.50 | --- |
| D2/E2 | --- | 3.41 | --- |
| e | --- | 0.50 | --- |
| b | 0.22 | 0.25 | 0.28 |
| f | 0.22 | 0.25 | 0.28 |
| L | 0.32 | 0.35 | 0.38 |
| s | --- | 0.12 | --- |
| x | 0.32 | 0.35 | 0.38 |

11.3 PCB Design Guidelines:

The Pad Diagram using a JEDEC type extension with solder rising on the outer edge is shown below. The Pad Dimensions Table shows pad sizing (mean dimensions) recommended for the MPU-9150 product.

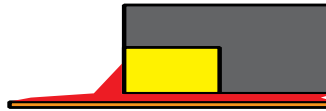

JEDEC type extension with solder rising on outer edge

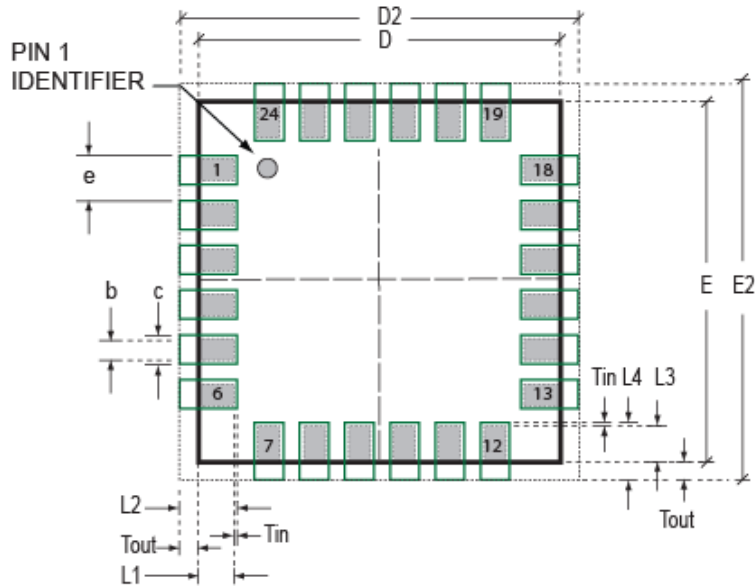

PCB Lay-out Diagram

| SYMBOLS | DIMENSIONS IN MILLIMETERS | NOM |
|---|---------------------------|------|
| Nominal Package I/O Pad Dimensions | | |
| e | Pad Pitch | 0.50 |
| b | Pad Width | 0.25 |
| L1 | Pad Length | 0.35 |
| L3 | Pad Length | 0.40 |
| D | Package Width | 4.00 |
| E | Package Length | 4.00 |
| I/O Land Design Dimensions (Guidelines) | | |
| D2 | I/O Pad Extent Width | 4.80 |
| E2 | I/O Pad Extent Length | 4.80 |
| c | Land Width | 0.35 |
| Tout | Outward Extension | 0.40 |
| Tin | Inward Extension | 0.05 |
| L2 | Land Length | 0.80 |
| L4 | Land Length | 0.85 |

PCB Dimensions Table (for PCB Lay-out Diagram)

11.4 Assembly Precautions

11.4.1 Surface Mount Guidelines

InvenSense MEMS motion sensors are sensitive to mechanical stress coming from the printed circuit board (PCB). This PCB stress can be minimized by adhering to certain design rules.

When using MEMS components in plastic packages, PCB mounting and assembly can cause package stress. This package stress in turn can affect the output offset and its value over a wide range of temperatures. This stress is caused by the mismatch between the Coefficient of Linear Thermal Expansion (CTE) of the package material and the PCB. Care must be taken to avoid package stress due to mounting.

Traces connected to pads should be as symmetric as possible. Maximizing symmetry and balance for pad connection will help component self alignment and will lead to better control of solder paste reduction after reflow.

Any material used in the surface mount assembly process of the MEMS product should be free of restricted RoHS elements or compounds. Pb-free solders should be used for assembly.

11.4.2 Exposed Die Pad Precautions

The MPU-9150 has very low active and standby current consumption. The exposed center die pad is not required for heat sinking, and should not be soldered to the PCB. Under-fill should also not be used. Failure to adhere to this rule can induce performance changes due to package thermo-mechanical stress. There is no electrical connection between the pad and the CMOS.

11.4.3 Trace Routing

Routing traces or vias under the gyro package such that they run under the exposed die pad is prohibited. Routed active signals may harmonically couple with the gyro MEMS devices, compromising gyro response. These devices are designed with the drive frequencies as follows: $X = 33 \pm 3\text{kHz}$, $Y = 30 \pm 3\text{kHz}$, and $Z = 27 \pm 3\text{kHz}$. To avoid harmonic coupling don't route active signals in non-shielded signal planes directly below, or above the gyro package. Note: For best performance, design a ground plane under the e-pad to reduce PCB signal noise from the board on which the gyro device is mounted. If the gyro device is stacked under an adjacent PCB board, design a ground plane directly above the gyro device to shield active signals from the adjacent PCB board.

11.4.4 Component Placement

Do not place large insertion components such as keyboard or similar buttons, connectors, or shielding boxes at a distance of less than 6 mm from the MEMS gyro. Maintain generally accepted industry design practices for component placement near the MPU-9150 to prevent noise coupling and thermo-mechanical stress.

11.4.5 PCB Mounting and Cross-Axis Sensitivity

Orientation errors of the gyroscope and accelerometer mounted to the printed circuit board can cause cross-axis sensitivity in which one gyro or accel responds to rotation or acceleration about another axis, respectively. For example, the X-axis gyroscope may respond to rotation about the Y or Z axes. The orientation mounting errors are illustrated in the figure below.

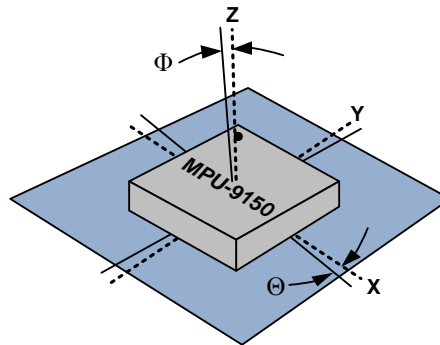

Package Gyro & Accel Axes (.....) Relative to PCB Axes (——) with Orientation Errors (Θ and Φ)

The table below shows the cross-axis sensitivity as a percentage of the specified gyroscope or accelerometer's sensitivity for a given orientation error, respectively.

Cross-Axis Sensitivity vs. Orientation Error

| Orientation Error (θ or Φ) | Cross-Axis Sensitivity ($\sin\theta$ or $\sin\Phi$) |
|---|--|
| 0° | 0% |
| 0.5° | 0.87% |
| 1° | 1.75% |

The specifications for cross-axis sensitivity in Section 6.1 and Section 6.2 include the effect of the die orientation error with respect to the package.

11.4.6 MEMS Handling Instructions

MEMS (Micro Electro-Mechanical Systems) are a time-proven, robust technology used in hundreds of millions of consumer, automotive and industrial products. MEMS devices consist of microscopic moving mechanical structures. They differ from conventional IC products, even though they can be found in similar packages. Therefore, MEMS devices require different handling precautions than conventional ICs prior to mounting onto printed circuit boards (PCBs).

The MPU-9150 has been qualified to a shock tolerance of 10,000g. InvenSense packages its gyroscopes as it deems proper for protection against normal handling and shipping. It recommends the following handling precautions to prevent potential damage.

- Do not drop individually packaged gyroscopes, or trays of gyroscopes onto hard surfaces. Components placed in trays could be subject to g-forces in excess of 10,000g if dropped.
- Printed circuit boards that incorporate mounted gyroscopes should not be separated by manually snapping apart. This could also create g-forces in excess of 10,000g.

- Do not clean MEMS gyroscopes in ultrasonic baths. Ultrasonic baths can induce MEMS damage if the bath energy causes excessive drive motion through resonant frequency coupling.

11.4.7 ESD Considerations

Establish and use ESD-safe handling precautions when unpacking and handling ESD-sensitive devices.

- Store ESD sensitive devices in ESD safe containers until ready for use. The Tape-and-Reel moisture-sealed bag is an ESD approved barrier. The best practice is to keep the units in the original moisture sealed bags until ready for assembly.
- Restrict all device handling to ESD protected work areas that measure less than 200V static charge. Ensure that all workstations and personnel are properly grounded to prevent ESD.

11.5 Reflow Specification

Qualification Reflow: The MPU-9150 was qualified in accordance with IPC/JEDEC J-STD-020D.1. This standard classifies proper packaging, storage and handling in order to avoid subsequent thermal and mechanical damage during the solder reflow attachment phase of PCB assembly.

The qualification preconditioning process specifies a sequence consisting of a bake cycle, a moisture soak cycle (in a temperature humidity oven), and three consecutive solder reflow cycles, followed by functional device testing.

The peak solder reflow classification temperature requirement for package qualification is (260 +5/-0°C) for lead-free soldering of components measuring less than 1.6 mm in thickness. The qualification profile and a table explaining the set-points are shown below:

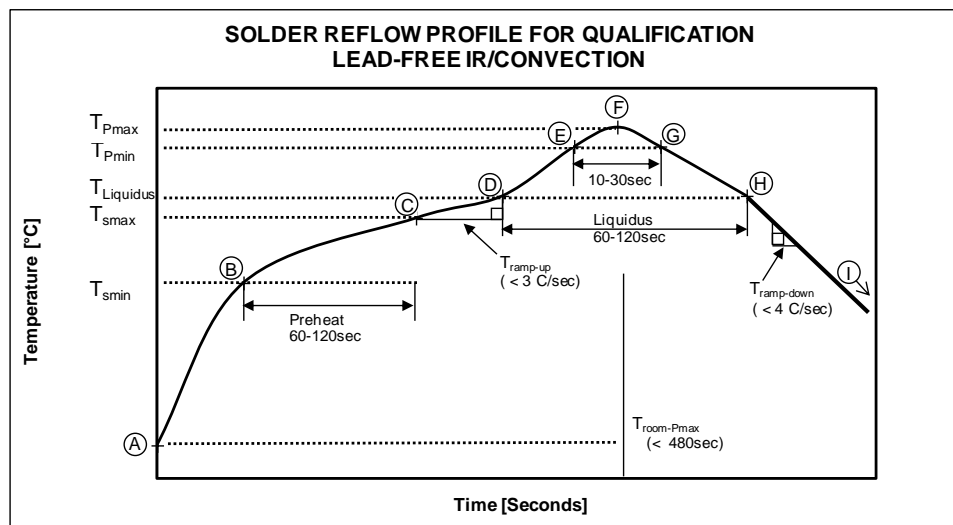

Temperature Set Points Corresponding to Reflow Profile Above

| Step | Setting | CONSTRAINTS | | |
|------|----------------------------------|-------------|----------------------------|--|
| | | Temp (°C) | Time (sec) | Max. Rate (°C/sec) |
| A | T _{room} | 25 | | |
| B | T _{Smin} | 150 | | |
| C | T _{Smax} | 200 | 60 < t _{BC} < 120 | |
| D | T _{Liquidus} | 217 | | r(T _{Liquidus} -T _{Pmax}) < 3 |
| E | T _{Pmin} [255°C, 260°C] | 255 | | r(T _{Liquidus} -T _{Pmax}) < 3 |
| F | T _{Pmax} [260°C, 265°C] | 260 | t _{AF} < 480 | r(T _{Liquidus} -T _{Pmax}) < 3 |
| G | T _{Pmin} [255°C, 260°C] | 255 | 10 < t _{EG} < 30 | r(T _{Pmax} -T _{Liquidus}) < 4 |
| H | T _{Liquidus} | 217 | 60 < t _{DH} < 120 | |
| I | T _{room} | 25 | | |

Notes: Customers must never exceed the Classification temperature (T_{Pmax} = 260°C).
 All temperatures refer to the topside of the QFN package, as measured on the package body surface.

Production Reflow: Check the recommendations of your solder manufacturer. For optimum results, use lead-free solders that have lower specified temperature profiles (T_{pmax} ~ 235°C). Also use lower ramp-up and ramp-down rates than those used in the qualification profile. Never exceed the maximum conditions that we used for qualification, as these represent the maximum tolerable ratings for the device.

11.6 Storage Specifications

The storage specification of the MPU-9150 conforms to IPC/JEDEC J-STD-020D.1 Moisture Sensitivity Level (MSL) 3.

| | |
|--|---|
| Calculated shelf-life in moisture-sealed bag | 12 months -- Storage conditions: <40°C and <90% RH |
| After opening moisture-sealed bag | 168 hours -- Storage conditions: ambient ≤30°C at 60%RH |

11.7 Package Marking Specification

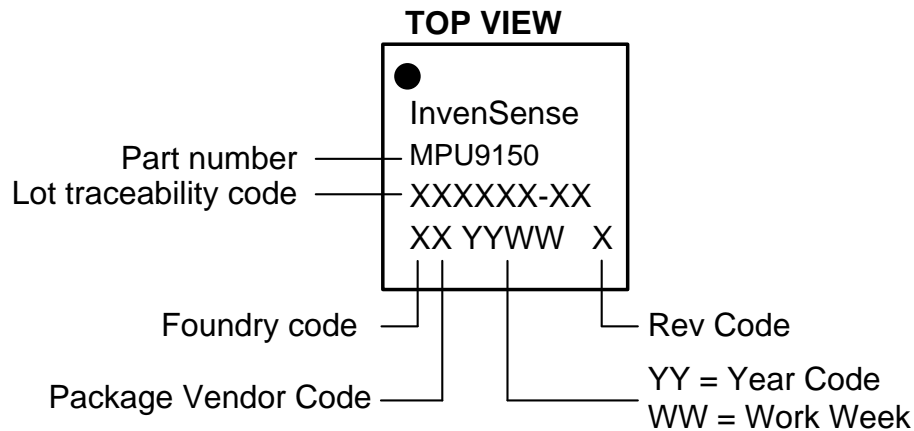

Package Marking Specification

11.8 Tape & Reel Specification

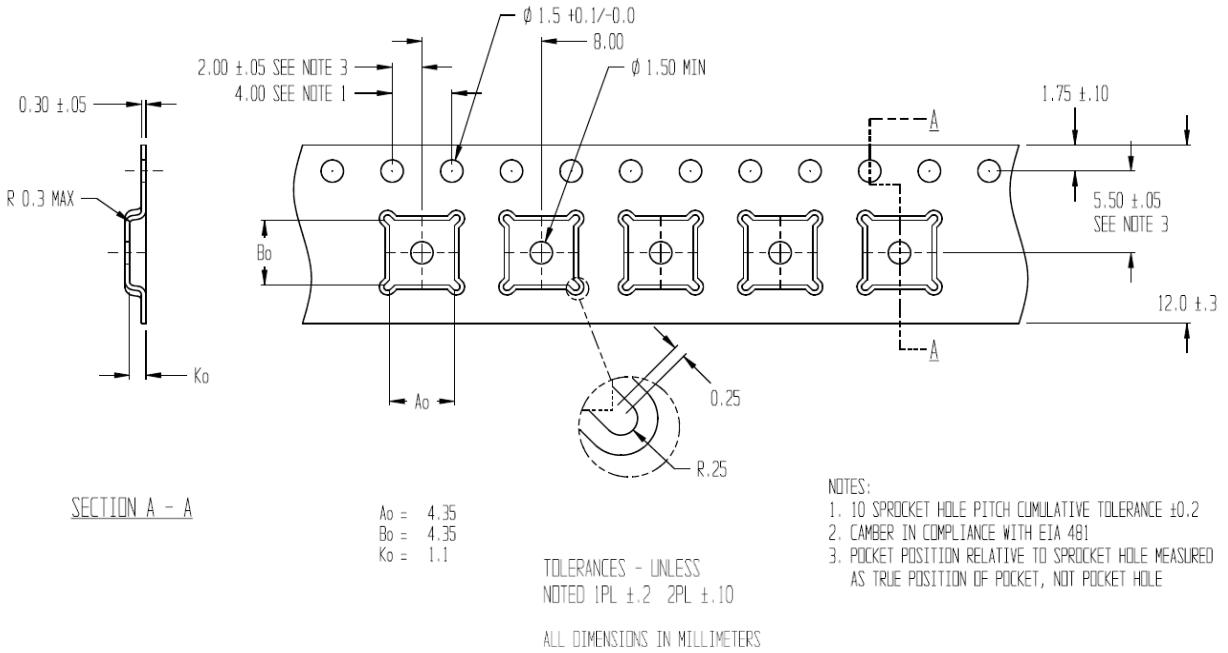

Tape Dimensions

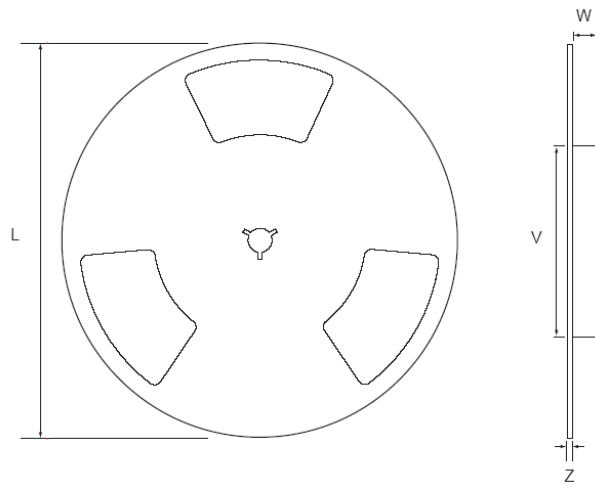

Reel Outline Drawing

Reel Dimensions and Package Size

| PACKAGE SIZE | REEL (mm) | | | |
|--------------|-----------|-----|------|-----|
| | L | V | W | Z |
| 4x4 | 330 | 102 | 12.8 | 2.3 |

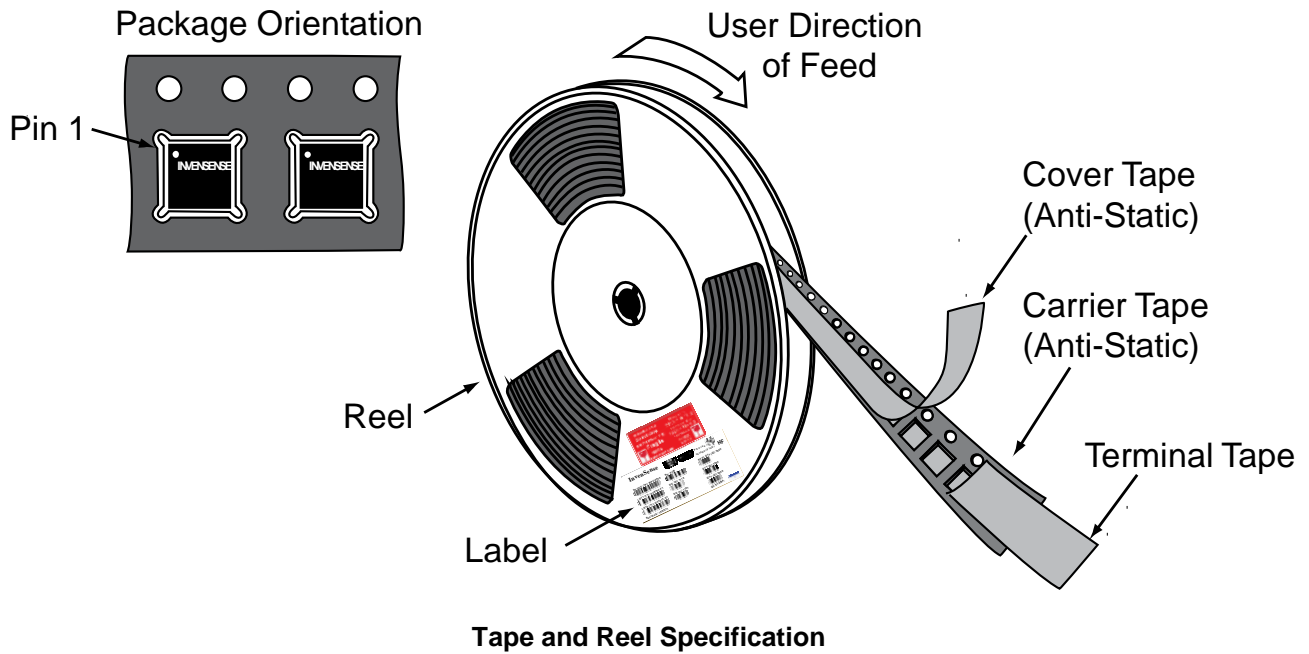

Reel Specifications

| | |
|------------------------|--------|
| Quantity Per Reel | 5,000 |
| Reels per Box | 1 |
| Boxes Per Carton (max) | 5 |
| Pcs/Carton (max) | 25,000 |

11.9 Label

InvenSense

Underfill **MSL3** Pb-free **Pb** category (e4) HF

DEVICE (1P): MPU-9150
 PO: HUB
 REEL QTY (Q): 5000

LOT1 (1T): Q2R994-F1
 D/C (D): 1204
 QTY (Q): 615

LOT2 (1T): Q3X785-G1
 D/C (D): 1207
 QTY (Q): 4385

Reel Date: 28/04/12
 QC STAMP: **OP01**



Location of Label

11.10 Packaging



REEL – with Barcode & Caution labels



Vacuum-Sealed Moisture Barrier Bag with ESD, MSL3, Caution, and Barcode Labels



MSL3 Label



Caution Label



ESD Label



Inner Bubble Wrap



Pizza Box



Pizza Boxes Placed in Foam-Lined Shipper Box



Outer Shipper Label



MPU-9150 Product Specification

Document Number: PS-MPU-9150A-00
Revision: 4.3
Release Date: 9/18/2013

11.11 Representative Shipping Carton Label

| | | | |
|--|-------------------------|--|--|
| | | INV. NO: 111013-99 | |
| From: InvenSense Taiwan, Ltd. 1F, 9 Prosperity 1st Road, Hsinchu Science Park, HsinChu City, 30078, Taiwan TEL: +886 3 6686999 FAX: +886 3 6686777 | | Ship To: Customer Name Street Address City, State, Country ZIP Attn: Buyer Name Phone: Buyer Phone Number | |
| SUPP PROD ID: MPU-9150 | | | |
| LOT#: Q2R994-F1 | | LOT#: | |
| QTY: 5615 | | QTY: 0 | |
| LOT#: Q3X785-G1 | | LOT#: | |
| QTY: 4385 | | QTY: 0 | |
| LOT#: Q3Y196-02 | | LOT#: | |
| QTY: 5000 | | QTY: 0 | |
| LOT#: | | LOT#: | |
| QTY: 0 | | QTY: 0 | |
| Total Quantity/Carton 15000 | | Weight: (KG) 4.05 | |
| Pb-free | Shipping Carton: | Category (e4) HF | |
| | 1 OF 3 | | |



12 Reliability

12.1 Qualification Test Policy

InvenSense's products complete a Qualification Test Plan before being released to production. The Qualification Test Plan for the MPU-9150 followed the JEDEC 471 Standards, "Stress-Test-Driven Qualification of Integrated Circuits," with the individual tests described below.

12.2 Qualification Test Plan

Accelerated Life Tests

| TEST | Method/Condition | Lot Quantity | Sample / Lot | Acc / Reject Criteria |
|---|--|--------------|--------------|-----------------------|
| (HTOL/LFR) High Temperature Operating Life | JEDEC JESD22-A108D Dynamic, 3.63V biased, T _j >125°C [read-points 168, 500, 1000 hours] | 3 | 77 | (0/1) |
| (HAST) Highly Accelerated Stress Test ⁽¹⁾ | JEDEC JESD22-A118A Condition A, 130°C, 85%RH, 33.3 psia., unbiased, [read-point 96 hours] | 3 | 77 | (0/1) |
| (HTS) High Temperature Storage Life | JEDEC JESD22-A103D Condition A, 125°C Non-Bias Bake [read-points 168, 500, 1000 hours] | 3 | 77 | (0/1) |

Device Component Level Tests

| TEST | Method/Condition | Lot Quantity | Sample / Lot | Acc / Reject Criteria |
|--|--|--------------|--------------|-----------------------|
| (ESD-HBM) ESD-Human Body Model | JEDEC JS-001-2012 (2KV) | 1 | 3 | (0/1) |
| (ESD-MM) ESD-Machine Model | JEDEC JESD22-A115C (250V) | 1 | 3 | (0/1) |
| (LU) Latch Up | JEDEC JESD-78D Class II (2), 125°C; ±100mA | 1 | 6 | (0/1) |
| (MS) Mechanical Shock | JEDEC JESD22-B104C, Mil-Std-883 Method 2002.5, Cond. E, 10,000g's, 0.2ms, ±X, Y, Z – 6 directions, 5 times/direction | 3 | 5 | (0/1) |
| (VIB) Vibration | JEDEC JESD22-B103B Variable Frequency (random), Cond. B, 5-500Hz, X, Y, Z – 4 times/direction | 1 | 5 | (0/1) |
| (TC) Temperature Cycling ⁽¹⁾ | JEDEC JESD22-A104D Condition G [-40°C to +125°C], Soak Mode 2 [5'], [Read-Points 1000 cycles] | 3 | 77 | (0/1) |

(1) Tests are preceded by MSL3 Preconditioning in accordance with JEDEC JESD22-A113F



13 Environmental Compliance

The MPU-9150 is RoHS and Green compliant.

The MPU-9150 is in full environmental compliance as evidenced in report HS-MPU-9150, Materials Declaration Data Sheet.

Environmental Declaration Disclaimer:

InvenSense believes this environmental information to be correct but cannot guarantee accuracy or completeness. Conformity documents for the above component constitutes are on file. InvenSense subcontracts manufacturing and the information contained herein is based on data received from vendors and suppliers, which has not been validated by InvenSense.

This information furnished by InvenSense is believed to be accurate and reliable. However, no responsibility is assumed by InvenSense for its use, or for any infringements of patents or other rights of third parties that may result from its use. Specifications are subject to change without notice. InvenSense reserves the right to make changes to this product, including its circuits and software, in order to improve its design and/or performance, without prior notice. InvenSense makes no warranties, neither expressed nor implied, regarding the information and specifications contained in this document. InvenSense assumes no responsibility for any claims or damages arising from information contained in this document, or from the use of products and services detailed therein. This includes, but is not limited to, claims or damages based on the infringement of patents, copyrights, mask work and/or other intellectual property rights.

Certain intellectual property owned by InvenSense and described in this document is patent protected. No license is granted by implication or otherwise under any patent or patent rights of InvenSense. This publication supersedes and replaces all information previously supplied. Trademarks that are registered trademarks are the property of their respective companies. InvenSense sensors should not be used or sold in the development, storage, production or utilization of any conventional or mass-destructive weapons or for any other weapons or life threatening applications, as well as in any other life critical applications such as medical equipment, transportation, aerospace and nuclear instruments, undersea equipment, power plant equipment, disaster prevention and crime prevention equipment.

InvenSense®, MotionCommand®, TouchAnywhere®, and AirSign® are registered trademarks of InvenSense, Inc. MPU™, MPU-9150™, Motion Processing Unit™, MotionFusion™, MotionProcessing™, MotionApps™, Digital Motion Processor™, Digital Motion Processing™, DMP™, BlurFree™, and InstantGesture™ are trademarks of InvenSense, Inc.

©2013 InvenSense, Inc. All rights reserved.



Looking for pricing, stock, or lifecycle information?

Click below to explore more details on WIN SOURCE:

 [View MOD-MPU9150 on WIN SOURCE](#)

 [Olimex LTD Information](#)

Optimize Your Supply Chain with WIN SOURCE Solutions

-  Global Sourcing Solution
-  Obsolete Management
-  Cost Control Management
-  Shortage Management
-  Alternative Solution
-  Excess Inventory Management