



**THE DATASHEET OF  
EV\_MPU-3050**



# **MPU-3050**

## **Motion Processing Unit**

### **Product Specification**

**TABLE OF CONTENTS**

**1 INTRODUCTION..... 4**

1.1 PURPOSE AND SCOPE ..... 4

1.2 PRODUCT OVERVIEW ..... 4

1.3 APPLICATIONS..... 5

**2 FEATURES ..... 6**

2.1 SENSORS..... 6

2.2 DIGITAL OUTPUT ..... 6

2.3 MOTION PROCESSING ..... 6

2.4 CLOCKING ..... 6

2.5 POWER..... 6

2.6 PACKAGE ..... 7

**3 ELECTRICAL CHARACTERISTICS ..... 8**

3.1 SENSOR SPECIFICATIONS ..... 8

3.2 ELECTRICAL SPECIFICATIONS..... 9

3.3 ELECTRICAL SPECIFICATIONS, CONTINUED ..... 10

3.4 ELECTRICAL SPECIFICATIONS, CONTINUED ..... 11

3.5 I<sup>2</sup>C TIMING CHARACTERIZATION ..... 12

3.6 ABSOLUTE MAXIMUM RATINGS ..... 13

**4 APPLICATIONS INFORMATION ..... 14**

4.1 PIN OUT AND SIGNAL DESCRIPTION ..... 14

4.2 TYPICAL OPERATING CIRCUITS..... 15

4.3 BILL OF MATERIALS FOR EXTERNAL COMPONENTS ..... 15

4.4 RECOMMENDED POWER-ON PROCEDURE..... 16

**5 FUNCTIONAL OVERVIEW ..... 17**

5.1 BLOCK DIAGRAM ..... 17

5.2 OVERVIEW ..... 17

5.3 THREE-AXIS MEMS GYROSCOPE WITH 16-BIT ADCs AND SIGNAL CONDITIONING ..... 17

5.4 DIGITAL MOTION PROCESSOR ..... 18

5.5 PRIMARY I<sup>2</sup>C SERIAL COMMUNICATIONS INTERFACE..... 18

5.6 SECONDARY I<sup>2</sup>C SERIAL INTERFACE (FOR A THIRD-PARTY ACCELEROMETER)..... 18

**6 CLOCKING ..... 19**

6.1 INTERNAL CLOCK GENERATION ..... 19

6.2 CLOCK OUTPUT ..... 19

6.3 SENSOR DATA REGISTERS ..... 19

6.4 FIFO..... 19

6.5 INTERRUPTS..... 19

6.6 BIAS AND LDO..... 20

6.7 CHARGE PUMP..... 20

6.8 CHIP VERSION..... 20

**7 DIGITAL INTERFACE..... 21**

7.1 I<sup>2</sup>C SERIAL INTERFACE..... 21

**8 SERIAL INTERFACE CONSIDERATIONS (MPU-3050)..... 25**

8.1 MPU-3050 SUPPORTED INTERFACES ..... 25

8.2 LOGIC LEVELS..... 25

**9 MOTION PROCESSING LIBRARY (MPL) .....28**

9.1 DEMO SOFTWARE..... 29

**10 ASSEMBLY .....29**

10.1 ORIENTATION ..... 29

10.2 PCB LAYOUT GUIDELINES ..... 30

10.3 TRACE ROUTING..... 32

10.4 COMPONENT PLACEMENT ..... 32

10.5 PCB MOUNTING AND CROSS-AXIS SENSITIVITY..... 33

10.6 PACKAGE MARKING SPECIFICATION..... 34

**11 REGISTER MAP ..... 35**

**12 REGISTER DESCRIPTION..... 36**

12.1 REGISTER 0 – WHO AM I ..... 36

12.2 REGISTER 01 – PRODUCT ID..... 37

12.3 REGISTERS 12 TO 17 – GYRO OFFSETS ..... 38

12.4 REGISTER 18 – FIFO ENABLE..... 39

12.5 REGISTER 19 – AUX (ACCEL) VDDIO ..... 39

12.6 REGISTER 20 – AUX (ACCEL) SLAVE ADDRESS ..... 40

12.7 REGISTER 21 – SAMPLE RATE DIVIDER..... 40

12.8 REGISTER 22 – DLPF, FULL SCALE, EXTERNAL SYNC..... 41

12.9 REGISTER 23 – INTERRUPT CONFIGURATION ..... 43

12.10 REGISTER 24 – AUX (ACCEL) BURST READ ADDRESS ..... 43

12.11 REGISTER 26 – INTERRUPT STATUS ..... 44

12.12 REGISTERS 27 TO 40 – SENSOR REGISTERS..... 44

12.13 REGISTERS 58 TO 59 – FIFO COUNT..... 45

12.14 REGISTER 60 – FIFO DATA ..... 45

12.15 REGISTER 61 – USER CONTROL ..... 47

12.16 REGISTER 62 – POWER MANAGEMENT..... 47

**13 REFERENCE.....49**

**14 REVISION HISTORY .....50**

## 1 Introduction

### 1.1 Purpose and Scope

This document provides a description, specifications, and design-related information for the MPU-3050 Motion Processing Unit ®. References [1], [2] and [3] provide a complementary set of software guides for the Motion Processing Library (MPL) and describe in detail the API and System Layer routines needed for interfacing to the MPU-3050.

Electrical characteristics are based upon simulation results and limited characterization data. Specifications are subject to change without notice.

### 1.2 Product Overview

The MPU-3050 Motion Processing Unit (MPU) is the world's first motion processing solution with integrated 6-axis sensor fusion for smartphone applications. The MPU-3050 has an embedded 3-axis gyroscope and Digital Motion Processor ® (DMP) hardware accelerator engine with a secondary I<sup>2</sup>C port that interfaces to third party digital accelerometers to deliver a complete 6-axis sensor fusion output to its primary I<sup>2</sup>C port. This combines both linear and rotational motion into a single data stream for the application. This breakthrough in gyroscope technology provides a dramatic 68% smaller footprint, 40% thinner package, consumes 55% less power, and has inherent cost advantages compared to the latest competitive gyro solutions to uniquely address the fast-growing demand for 6-axis motion processing in mobile handsets.

The MPU-3050 significantly extends and transforms motion sensing features provided by accelerometers beyond portrait and landscape orientation, to motion processing functionality. The MPU measures and processes both linear and rotational movements, creating a higher degree of 1:1 motion interactivity between the user and their handset. Similar to the proliferation of Bluetooth, camera phone image sensors and Wi-Fi, motion processing is becoming a “must-have” function in mobile handsets benefitting wireless carriers, mobile handset OEMs, application developers and end-users. By providing an integrated sensor fusion output, the DMP in the MPU-3050 offloads the intensive motion processing computation requirements from the applications processor, reducing the need for frequent polling of the motion sensor output and enabling use of low-cost, low-power application processors, thereby increasing overall battery life of handsets. Since handsets today are of multi-function nature, MPU-3050 not only provides accurate 1:1 motion tracking for some of the more common applications such as still/video image stabilization, gaming and dead reckoning, the 32-bit DMP can be programmed to deliver advanced UI, e.g. multiple kinds of gestures and character recognition leading to applications such as *Airsign*®, *TouchAnywhere*®, *MotionCommand*®.

By leveraging its patented and volume-proven Nasiri-Fabrication platform, which integrates MEMS wafers with companion CMOS electronics through wafer-level bonding, InvenSense has driven the MPU-3050 package size down to a revolutionary footprint of 4x4x0.9mm (QFN), while providing the highest performance, lowest noise, and the lowest cost semiconductor packaging to address a wide range of handheld consumer electronic devices.

The MPU-3050 integrates 16-bit analog-to-digital converters (ADCs), selectable low-pass filters, FIFO, embedded temperature sensor, and Fast Mode I<sup>2</sup>C interface. Performance features include programmable full-scale range from 250 degrees-per-second up to 2000 degrees-per-second (°/s or dps), and low-noise of 0.01°/s/√Hz, while providing the highest robustness supporting 10,000g shock in operation. The highest cross-axis isolation is achieved by design from its single silicon integration. Factory-calibrated initial sensitivity reduces production-line calibration requirements. The part's on-chip FIFO and dedicated I<sup>2</sup>C-master accelerometer sensor bus simplifies system timing and lowers system power consumption. The sensor bus allows the MPU-3050 to directly acquire data from the off-chip

[1] MPL Programmer's Guide – Application Note (AN-MPL-3000-UG-01 or later)  
 [2] MPL Functional Specification (DOC-MPL-FS-V2.3 or later)  
 [3] MPL Product Specification (PS-MPL-3000-v2.0 or later)

accelerometer without intervention from an external processor. Other industry-leading features include a small 4 mm x 4 mm x 0.9 mm plastic QFN package, an embedded temperature sensor, programmable interrupts, and a low 13 mW power consumption. Parts are available with I<sup>2</sup>C serial interface, a VDD operating range of 2.1 V to 3.6 V, and a VLOGIC interface voltage from 1.71 V to 3.6 V.

The MPU-3050 supports the I<sup>2</sup>C serial interface and has a separate VLOGIC reference pin (in addition to its analog supply pin, VDD), which sets the logic levels of its I<sup>2</sup>C interface. The VLOGIC voltage may be between 1.71 V min to VDD max. The table below outlines these details:

**Power Supply and supported interface for MPU-3050**

Part / Item	MPU-3050
VDD	2.1 V to 3.6 V
VLOGIC	1.71 V to VDD
Serial Interfaces Supported	I <sup>2</sup> C
Pin 8	VLOGIC
Pin 9	AD0
Pin 23	SCL
Pin 24	SDA

**1.3 Applications**

- Handset gaming
- Location-based services, points of interest, and dead reckoning
- Improved camera image quality through image stabilization
- Health and sports monitoring

## 2 Features

The MPU-3050 Motion Processing Unit includes a wide range of features:

### 2.1 Sensors

- X-, Y-, Z-Axis angular rate sensors (gyros) on one integrated circuit
- Digital-output temperature sensor
- External sync signal connected to the FSYNC pin supports image, video and GPS synchronization
- 6-axis motion processing capability using secondary I<sup>2</sup>C interface to directly connect to a digital 3-axis third-party accelerometer
- Factory calibrated scale factor
- High cross-axis isolation via proprietary MEMS design
- 10,000g shock tolerant

### 2.2 Digital Output

- Fast Mode (400 kHz) I<sup>2</sup>C serial interface
- 16-bit ADCs for digitizing sensor outputs
- Angular rate sensors (gyros) with applications-programmable full-scale-range of  $\pm 250^\circ/\text{sec}$ ,  $\pm 500^\circ/\text{sec}$ ,  $\pm 1000^\circ/\text{sec}$ , or  $\pm 2000^\circ/\text{sec}$ .

### 2.3 Motion Processing

- Embedded Digital Motion Processing engine supports 3D motion processing and gesture recognition algorithms
- When used together with a digital 3-axis third party accelerometer, the MPU-3050 collects the accelerometer data via a dedicated interface, while synchronizing data sampling at a user defined rate. The total data set obtained by the MPU-3050 includes 3-axis gyroscope data and 3-axis accelerometer data, temperature data, and the one bit external sync signal connected to the FSYNC pin. The MPU also downloads the results calculated by the digital 3-axis third party accelerometer internal registers.
- FIFO buffers complete data set, reducing timing requirements on the system processor and saving power by letting the processor burst read the FIFO data, and then go into a low-power sleep mode while the MPU collects more data.
- Programmable interrupt supports features such as gesture recognition, panning, zooming, scrolling, zero-motion detection, tap detection, and shake detection
- Hand jitter filter
- Programmable low-pass filters
- Feature extraction for peak and zero-crossing detection
- Pedometer functionality

### 2.4 Clocking

- On-chip timing generator clock frequency +/-2% over full temperature range
- Optional external clock inputs of 32.768kHz or 19.2 MHz
- 1 MHz clock output to synchronize with digital 3-axis accelerometer

### 2.5 Power

- VDD supply voltage range of 2.1 V to 3.6 V
- Flexible VLOGIC reference voltage allows for multiple I<sup>2</sup>C interface voltage
- Power consumption with all three axis and DMP active: 6.1 mA
- Sleep mode: 5  $\mu\text{A}$
- Each axis can be individually powered down

**2.6 Package**

- 4 x 4 x 0.9 mm QFN plastic package
- MEMS structure hermetically sealed and bonded at wafer level
- RoHS and Green compliant

### 3 Electrical Characteristics

#### 3.1 Sensor Specifications

Typical Operating Circuit of Section 4.2, VDD = 2.5 V, VLOGIC = 2.5 V, TA=25°C.

Parameter	Conditions	Min	Typical	Max	Unit	Notes
<b>GYRO SENSITIVITY</b>						
Full-Scale Range	FS_SEL = 0		±250		%s	4, 7
	FS_SEL = 1		±500			4, 7
	FS_SEL = 2		±1000			4, 7
	FS_SEL = 3		±2000			4, 7
Gyro ADC Word Length			16		Bits	3
Sensitivity Scale Factor	FS_SEL = 0		131		LSB/(°/s)	1
	FS_SEL = 1		65.5			3
	FS_SEL = 2		32.8			3
	FS_SEL = 3		16.4			3
Sensitivity Scale Factor Tolerance	25°C	-6	±2	+6	%	1
Sensitivity Scale Factor Variation Over Temperature	-40°C to +85°C		±2		%	8
Nonlinearity	Best fit straight line; 25°C		0.2		%	6
Cross-Axis Sensitivity			2		%	6
<b>GYRO ZERO-RATE OUTPUT (ZRO)</b>						
Initial ZRO Tolerance	25°C		±20		%s	1
ZRO Variation Over Temperature	-40°C to +85°C		±0.15		%s/°C	8
Power-Supply Sensitivity (1-10 Hz)	Sine wave, 100mVpp; VDD = 2.2 V		0.2		%s	5
Power-Supply Sensitivity (10 – 250 Hz)	Sine wave, 100mVpp; VDD = 2.2 V		0.2		%s	5
Power-Supply Sensitivity (250 Hz – 100 kHz)	Sine wave, 100mVpp; VDD = 2.2 V		4		%s	5
Linear Acceleration Sensitivity	Static		0.1		%s/g	6
<b>GYRO NOISE PERFORMANCE</b>						
Total RMS Noise	FS_SEL=0 DLPFCFG = 2 (100 Hz)		0.1		%s-rms	1
Low-frequency RMS noise	Bandwidth 1 Hz to 10 Hz		0.033		%s-rms	1
Rate Noise Spectral Density	At 10 Hz		0.01		%s/√Hz	3
<b>GYRO MECHANICAL FREQUENCIES</b>						
X-Axis		30	33	36	kHz	1
Y-Axis		27	30	33	kHz	1
Z-Axis		24	27	30	kHz	1
<b>GYRO START-UP TIME</b>						
ZRO Settling	DLPFCFG = 0 to ±1%/s of Final		50		ms	5
<b>TEMPERATURE RANGE</b>						
Specified Temperature Range		-40		85	°C	2

**Notes:**

1. Tested in production
2. Based on characterization of 30 parts over temperature on evaluation board or in socket
3. Based on design, through modeling and simulation across PVT
4. Typical. Randomly selected part measured at room temperature on evaluation board or in socket
5. Based on characterization of 5 parts over temperature
6. Tested on 20 parts at room temperature
7. Part is characterized to Full-Scale Range. Maximum ADC output is  $[2^{16} / (\text{Sensitivity} \times 2)]$   
Example: For Sensitivity of 131 LSB/(°/s),  $[2^{16} / (131 \times 2)] = \pm 250$  %s.
8. Based on characterization of 48 parts on evaluation board or in socket

**3.2 Electrical Specifications**

Typical Operating Circuit of Section 4.2, VDD = 2.5 V, VLOGIC = 2.5 V, TA = 25°C.

Parameters	Conditions	Min	Typical	Max	Units	Notes
<b>VDD POWER SUPPLY</b>						
Operating Voltage Range	Monotonic ramp. Ramp rate is 10% to 90% of the final value (see Figure in Section 4.4)	2.1		3.6	V	2
Power-Supply Ramp Rate		0		5	ms	2
Normal Operating Current				6.1 5.9		mA mA
Sleep Mode Current	DMP disabled		5		µA	4
<b>VLOGIC REFERENCE VOLTAGE</b>						
Voltage Range	VLOGIC must be ≤VDD at all times	1.71		VDD	V	
Power-Supply Ramp Rate	Monotonic ramp. Ramp rate is 10% to 90% of the final value			1	ms	3, 5
Normal Operating Current	(see Figure in Section 4.4)		100		µA	
<b>START-UP TIME FOR REGISTER READ/WRITE</b>			20	100	ms	4
<b>I<sup>2</sup>C ADDRESS</b>	AD0 = 0 AD0 = 1		1101000 1101001			1
<b>DIGITAL INPUTS (SDI, SCLK, FSYNC, AD0, /CS, CLKIN)</b>						
V <sub>IH</sub> , High Level Input Voltage		0.7*VDD			V	4
V <sub>IL</sub> , Low Level Input Voltage				0.3*VDD	V	4
<b>DIGITAL OUTPUT (INT)</b>						
V <sub>OH</sub> , High Level Output Voltage	R <sub>LOAD</sub> = 1 MΩ	0.9*VLOGIC			V	2
V <sub>OL1</sub> , LOW-Level Output Voltage	R <sub>LOAD</sub> = 1 MΩ			0.1*VLOGIC	V	2
V <sub>OL,INT1</sub> , INT Low-Level Output Voltage	OPEN =1, 0.3 mA sink current			0.1	V	2
Output Leakage Current	OPEN = 1		100		nA	3
t <sub>INT</sub> , INT Pulse Width	LATCH_INT_EN = 0		50		µs	3

**Notes:**

1. Tested in production
2. Based on characterization of 30 parts over temperature on evaluation board or in socket
3. Typical. Randomly selected part measured at room temperature on evaluation board or in socket
4. Based on characterization of 5 parts over temperature
5. Refer to Section 4.4 for the recommended power-on procedure

**3.3 Electrical Specifications, continued**

Typical Operating Circuit of Section 4.2, VDD = 2.5 V, VLOGIC = 2.5 V, TA=25°C.

Parameters	Conditions	Typical	Units	Notes
<b>Primary I<sup>2</sup>C I/O (SCL, SDA)</b>				
V <sub>IL</sub> , LOW Level Input Voltage	MPU-3050	0.5V to 0.3*VLOGIC	V	1
V <sub>IH</sub> , HIGH-Level Input Voltage	MPU-3050	0.7*VLOGIC to VLOGIC + 0.5 V	V	1
V <sub>hys</sub> , Hysteresis	MPU-3050	0.1*VLOGIC	V	1
V <sub>OL1</sub> , LOW-Level Output Voltage	3mA sink current	0 to 0.4	V	1
I <sub>OL</sub> , LOW-Level Output Current	V <sub>OL</sub> = 0.4V	3	mA	1
	V <sub>OL</sub> = 0.6V	5	mA	1
Output Leakage Current		100	nA	2
t <sub>of</sub> , Output Fall Time from V <sub>IHmax</sub> to V <sub>ILmax</sub>	C <sub>b</sub> bus capacitance in pf	20+0.1C <sub>b</sub> to 250	ns	1
<b>Secondary I<sup>2</sup>C I/O (AUX_CL, AUX_DA)</b>				
<b>ACCEL_VDDIO=0</b>				
V <sub>IL</sub> , LOW-Level Input Voltage		-0.5 V to 0.3*VLOGIC	V	1
V <sub>OL1</sub> , LOW-Level Output Voltage	VLOGIC > 2V; 1mA sink current	0 to 0.4	V	1
V <sub>OL3</sub> , LOW-Level Output Voltage	VLOGIC < 2V; 1mA sink current	0 to 0.2*VLOGIC	V	1
I <sub>OL</sub> , LOW-Level Output Current	V <sub>OL</sub> = 0.4V	1	mA	1
	V <sub>OL</sub> = 0.6V	1	mA	1
Output Leakage Current		100	nA	2
t <sub>of</sub> , Output Fall Time from V <sub>IHmax</sub> to V <sub>ILmax</sub>	C <sub>b</sub> bus capacitance in pf	20+0.1C <sub>b</sub> to 250	ns	1
<b>ACCEL_VDDIO = 1</b>				
V <sub>IL</sub> , LOW-Level Input Voltage		-0.5 to 0.3*VDD	V	1
V <sub>IH</sub> , HIGH-Level Input Voltage		0.7*VDD to VDD + 0.5 V	V	1
V <sub>OL1</sub> , LOW-Level Output Voltage	1mA sink current	0 to 0.4	V	1
I <sub>OL</sub> , LOW-Level Output Current	V <sub>OL</sub> = 0.4 V	1	mA	1
	V <sub>OL</sub> = 0.6 V	1	mA	1
Output Leakage Current		100	nA	2
t <sub>of</sub> , Output Fall Time from V <sub>IHmax</sub> to V <sub>ILmax</sub>	C <sub>b</sub> bus cap. in pF	20+0.1C <sub>b</sub> to 250	ns	1

**Notes:**

1. Based on characterization of 5 parts over temperature.
2. Typical. Randomly selected part measured at room temperature on evaluation board or in socket.

**3.4 Electrical Specifications, continued**

Typical Operating Circuit of Section 4.2, VDD = 2.5 V, VLOGIC = 2.5 V, TA=25°C.

Parameters	Conditions	Min	Typical	Max	Units	Notes
<b>INTERNAL CLOCK SOURCE</b>						
Sample Rate, Fast	CLK_SEL = 0,1,2,3 DLPFCFG = 0 SAMPLERATEDIV = 0		8		kHz	3
Sample Rate, Slow	DLPFCFG = 1,2,3,4,5, or 6 SAMPLERATEDIV = 0		1		kHz	3
Reference Clock Output	CLKOUTEN = 1		1.024		MHz	3
Clock Frequency Initial Tolerance	CLK_SEL = 0, 25°C	-5		+5	%	1
	CLK_SEL = 1,2,3; 25°C	-1		+1	%	1
Frequency Variation over Temperature	CLK_SEL = 0		-15 to +10		%	2
	CLK_SEL =1,2,3		+/-1		%	2
PLL Settling Time	CLK_SEL=1,2,3		1		ms	3
<b>EXTERNAL 32.768kHz CLOCK</b>						
External Clock Frequency	CLK_SEL=4		32.768		kHz	
External Clock Jitter	Cycle-to-cycle rms		1 to 2		µs	
Sample Rate, Fast	DLPFCFG = 0 SAMPLERATEDIV = 0		8.192		kHz	
Sample Rate, Slow	DLPFCFG = 1,2,3,4,5, or 6 SAMPLERATEDIV = 0		1.024		kHz	
Reference Clock Output	CLKOUTEN = 1		1.0486		MHz	
PLL Settling Time			1		ms	
<b>EXTERNAL 19.2 MHz CLOCK</b>						
External Clock Frequency	CLK_SEL = 5		19.2		MHz	
Sample Rate, Fast	DLPFCFG = 0 SAMPLERATEDIV = 0		8		kHz	
Sample Rate, Slow	DLPFCFG = 1,2,3,4,5, or 6 SAMPLERATEDIV = 0		1		kHz	
Reference Clock Output	CLKOUTEN = 1		1.024		MHz	
PLL Settling Time			1		ms	

**Notes:**

1. Tested in production.
2. Based on characterization of 30 parts over temperature on evaluation board or in socket.
3. Typical. Randomly selected part measured at room temperature on evaluation board or in socket.

**3.5 I<sup>2</sup>C Timing Characterization**

Typical Operating Circuit of Section 4.2, VDD = 2.5 V, VLOGIC = 1.8 V ± 5%, 2.5 V ± 5%, 3.0 V ± 5%, o 3.3 V ± 5%, TA=25°C.

Parameters	Conditions	Min	Typical	Max	Units	Notes
<b>I<sup>2</sup>C TIMING</b>		<b>I<sup>2</sup>C FAST-MODE</b>				
f <sub>SCL</sub> , SCL Clock Frequency		0		400	kHz	1
t <sub>HD,STA</sub> , (Repeated) START Condition Hold Time		0.6			µs	1
t <sub>LOW</sub> , SCL Low Period		1.3			µs	1
t <sub>HIGH</sub> , SCL High Period		0.6			µs	1
t <sub>SU,STA</sub> , Repeated START Condition Setup Time		0.6			µs	1
t <sub>HD,DAT</sub> , SDA Data Hold Time		0			µs	1
t <sub>SU,DAT</sub> , SDA Data Setup Time		100			ns	1
t <sub>r</sub> , SDA and SCL Rise Time	C <sub>b</sub> bus cap. from 10 to 400pF	20+0.1C <sub>b</sub>		300	ns	1
t <sub>f</sub> , SDA and SCL Fall Time	C <sub>b</sub> bus cap. from 10 to 400pF	20+0.1C <sub>b</sub>		300	ns	1
t <sub>SU,STO</sub> , STOP Condition Setup Time		0.6			µs	1
t <sub>BUF</sub> , Bus Free Time Between STOP and START Condition		1.3			µs	1
C <sub>b</sub> , Capacitive Load for each Bus Line				400	pF	
t <sub>VD,DAT</sub> , Data Valid Time				0.9	µs	1
t <sub>VD,ACK</sub> , Data Valid Acknowledge Time				0.9	µs	1

**Notes:**

1. Based on characterization of 5 parts over temperature on evaluation board or in socket.

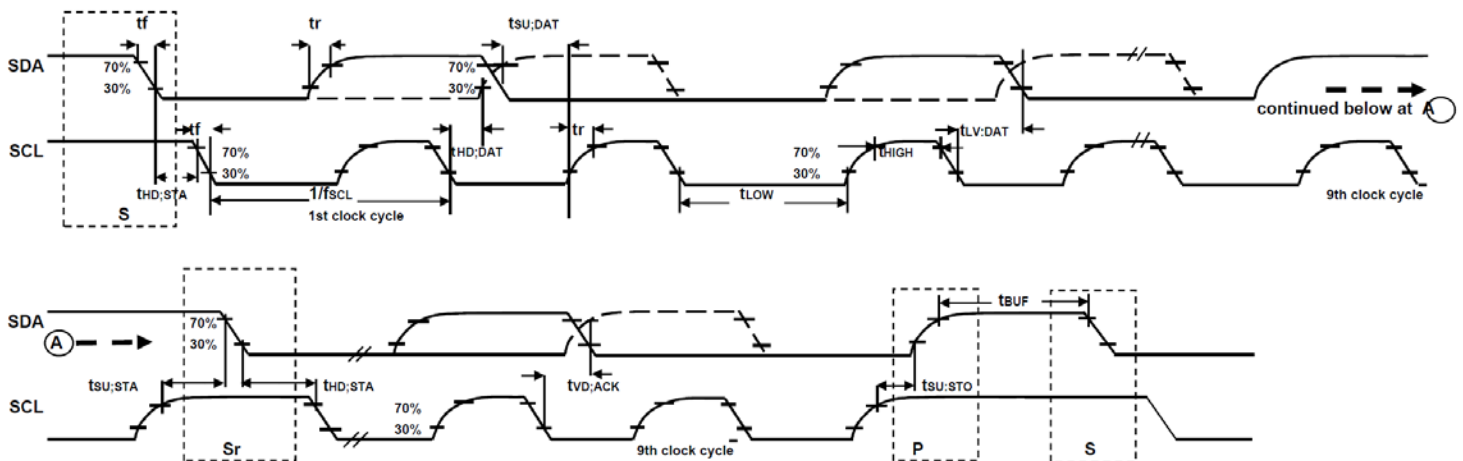

**I<sup>2</sup>C Bus Timing Diagram**

### 3.6 Absolute Maximum Ratings

Stress above those listed as “Absolute Maximum Ratings” may cause permanent damage to the device. These are stress ratings only and functional operation of the device at these conditions is not implied. Exposure to the absolute maximum ratings conditions for extended periods may affect device reliability.

#### Absolute Maximum Ratings

Parameter	Rating
Supply Voltage, VDD	-0.5 V to +6 V
VLOGIC Input Voltage Level (MPU-3050)	-0.5 V to VDD + 0.5 V
REGOUT	-0.5 V to 2 V
Input Voltage Level (CLKIN, AUX_DA, AD0, FSYNC, INT, SCL, SDA)	-0.5 V to VDD + 0.5 V
CPOUT (2.1V ≤ VDD ≤ 3.6V )	-0.5 V to 30 V
Acceleration (Any Axis, unpowered)	10,000g for 0.3 ms
Operating Temperature Range	-40°C to +105°C
Storage Temperature Range	-40°C to +125°C
Electrostatic Discharge (ESD) Protection	1.5 kV (HBM); 200 V (MM)
Latch-up	60 mA @ 125°C JEDEC Condition “B”

## 4 Applications Information

### 4.1 Pin Out and Signal Description

Pin Number	MPU-3050	Pin Name	Pin Description
1	Y	CLKIN	External reference clock input
6	Y	AUX_DA	Interface to a 3 <sup>rd</sup> party accelerometer, SDA pin. Logic levels are set to be either VDD or VLOGIC. See Section 7 for more details.
7	Y	AUX_CL	Interface to a 3 <sup>rd</sup> party accelerometer, SCL pin. Logic levels are set to be either VDD or VLOGIC. See Section 7 for more details.
8	Y	VLOGIC	Digital I/O supply voltage. VLOGIC must be $\leq$ VDD at all times.
9	Y	AD0	I <sup>2</sup> C Slave Address LSB
10	Y	REGOUT	Regulator filter capacitor connection
11	Y	FSYNC	Frame synchronization digital input
12	Y	INT	Interrupt digital output (totem pole or open-drain)
13	Y	VDD	Power supply voltage and Digital I/O supply voltage
18	Y	GND	Power supply ground
19	Y	RESV	Reserved. Do not connect.
20	Y	CPOUT	Charge pump capacitor connection
21	Y	RESV	Reserved. Do not connect.
22	Y	CLKOUT	1 MHz clock output for third-party accelerometer synchronization
23	Y	SCL	I <sup>2</sup> C serial clock
24	Y	SDA	I <sup>2</sup> C serial data
2, 3, 4, 5, 14, 15, 16, 17	Y	NC	Not internally connected. May be used for PCB trace routing.

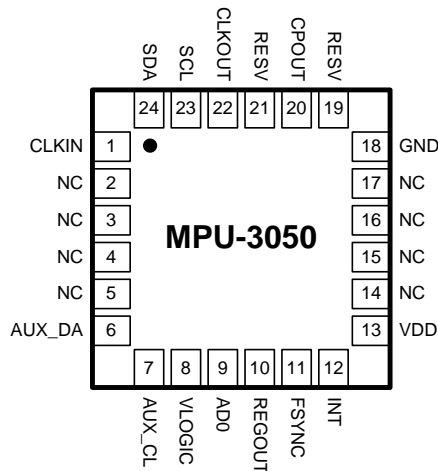

**QFN Package (Top View)**  
24-pin, 4mm x 4mm x 0.9mm

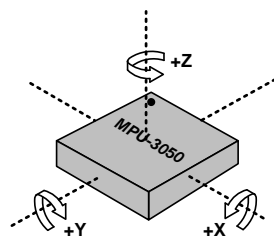

**Orientation of Axes of Sensitivity**  
**and Polarity of Rotation**

**4.2 Typical Operating Circuits**

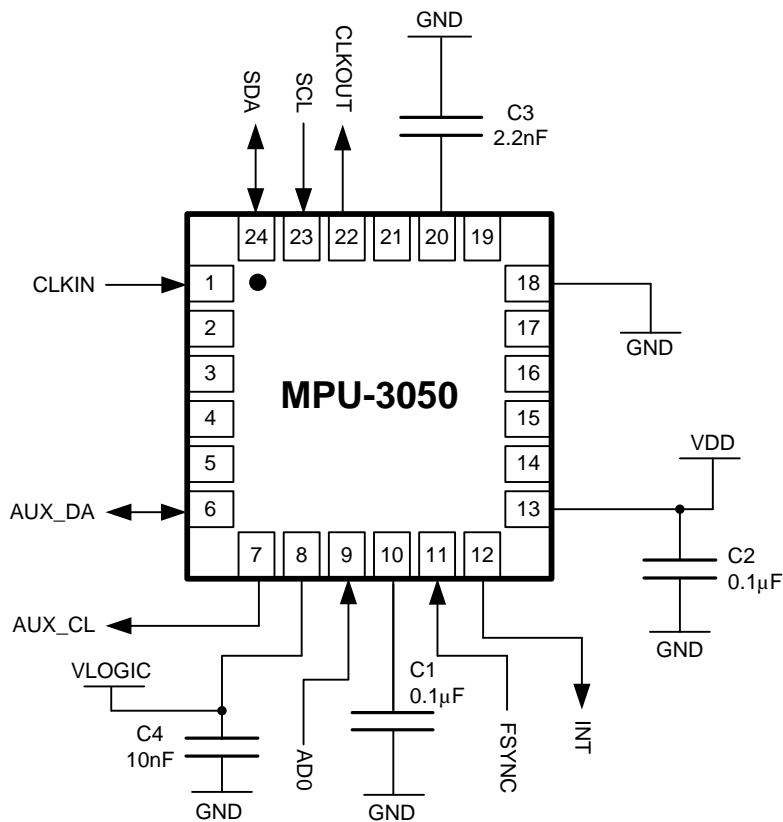

**Typical Operating Circuit**

**4.3 Bill of Materials for External Components**

Component	Label	Specification	Quantity
VDD Bypass Capacitor	C1	Ceramic, X7R, 0.1 µF ±10%, 4 V	1
Regulator Filter Capacitor	C2	Ceramic, X7R, 0.1 µF ±10%, 2 V	1
Charge Pump Capacitor	C3	Ceramic, X7R, 2.2 nF ±10%, 50 V	1
VLOGIC Bypass Capacitor	C4	Ceramic, X7R, 10 nF ±10%, 4 V	1

**4.4 Recommended Power-on Procedure**

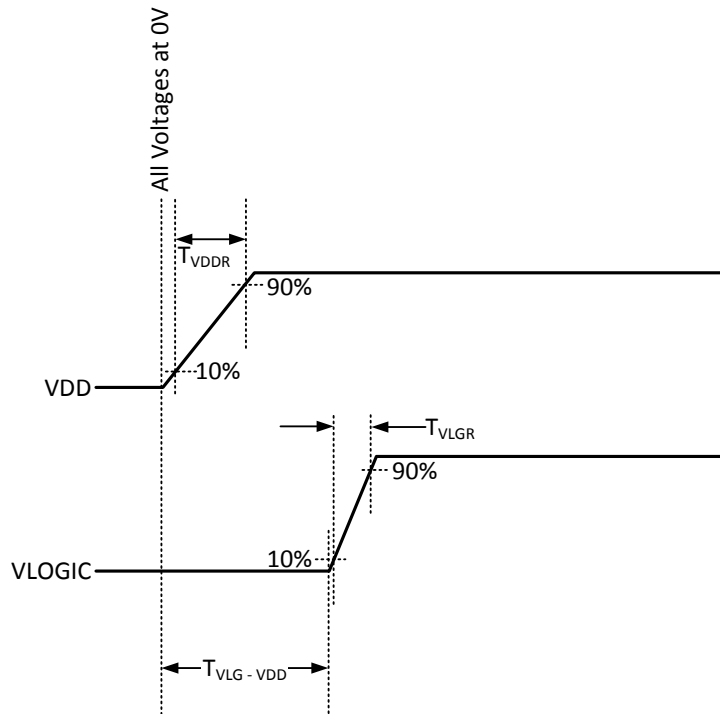

**Power-Up Sequencing**

1.  $T_{VDDR}$  is VDD rise time: Time for VDD to rise from 10% to 90% of its final value.
2.  $T_{VDDR}$  is  $\leq 10$  msec.
3.  $T_{VDDR}$  is VLOGIC rise time: Time for VLOGIC to rise from 10% to 90% of its final value.
4.  $T_{VLGR}$  is  $\leq 1$  msec.
5.  $T_{VLG-VDD}$  is the delay from the start of VDD ramp to the start of VLOGIC rise.
6.  $T_{VLG-VDD}$  is 0 to 20 msec but VLOGIC amplitude must always be  $\leq$  VDD amplitude.
7. VDD and VLOGIC must be monotonic ramps.

**5 Functional Overview**

**5.1 Block Diagram**

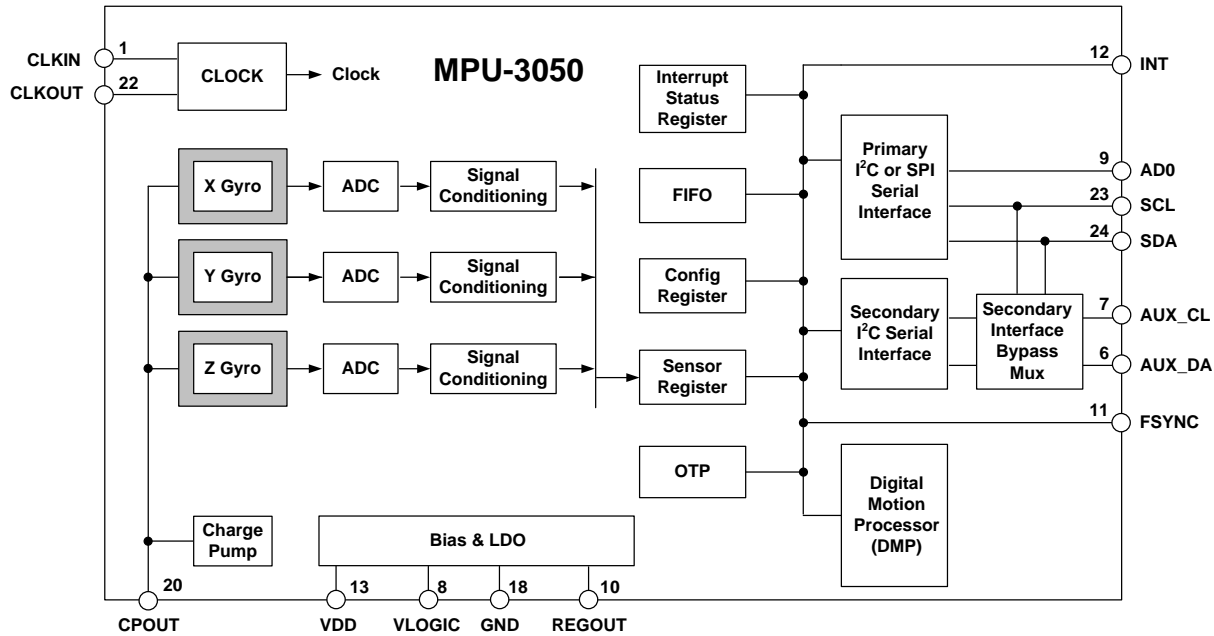

**5.2 Overview**

The MPU-3050 is comprised of the following key blocks / functions:

- Three-axis MEMS rate gyroscope sensors with 16-bit ADCs and signal conditioning
- Digital Motion Processor (DMP)
- Primary I<sup>2</sup>C serial communications interface
- Secondary I<sup>2</sup>C serial interface for 3<sup>rd</sup> party accelerometer
- Clocking
- Sensor Data Registers
- FIFO
- Interrupts
- Digital-Output Temperature Sensor
- Bias and LDO
- Charge Pump

**5.3 Three-Axis MEMS Gyroscope with 16-bit ADCs and Signal Conditioning**

The MPU-3050 consists of three independent vibratory MEMS rate gyroscopes, which detect rotation about the X, Y, and Z axes. When the gyros are rotated about any of the sense axes, the Coriolis Effect causes a vibration that is detected by a capacitive pickoff. The resulting signal is amplified, demodulated, and filtered to produce a voltage that is proportional to the angular rate. This voltage is digitized using individual on-chip 16-bit Analog-to-Digital Converters (ADCs) to sample each axis. The full-scale range of the gyro sensors may be digitally programmed to  $\pm 250$ ,  $\pm 500$ ,  $\pm 1000$ , or  $\pm 2000$  degrees per second (dps). ADC sample rate is

programmable from 8,000 samples per second, down to 3.9 samples per second, and user-selectable low-pass filters enable a wide range of cut-off frequencies.

#### 5.4 Digital Motion Processor

The embedded Digital Motion Processor (DMP) is located within the MPU-3050 and offloads computation of motion processing algorithms from the host processor. The DMP acquires data from accelerometers, gyroscopes, and additional sensors such as magnetometers, and processes the data. The resulting data can be read from the DMP's registers, or can be buffered in a FIFO. The DMP has access to some of MPU's external pins, which can be used for synchronizing external devices to the motion sensors, or generating interrupts for the application.

The purpose of the DMP is to offload both timing requirements and processing power from the host processor. Typically, motion processing algorithms should be run at a high rate, often around 200 Hz, in order to provide accurate results with low latency. This is required even if the application updates at a much lower rate; for example, a low power user interface may update as slowly as 5 Hz, but the motion processing should still run at 200 Hz. The DMP can be used as a tool in order to minimize power, simplify timing and software architecture, and save valuable MIPS on the host processor for use in the application.

#### 5.5 Primary I<sup>2</sup>C Serial Communications Interface

The MPU-3050 communicates to a system processor using I<sup>2</sup>C serial interface, and the device always acts as a slave when communicating to the system processor. The logic level for communications to the master is set by the voltage on the VLOGIC pin. The LSB of the I<sup>2</sup>C slave address is set by pin 9 (AD0).

#### 5.6 Secondary I<sup>2</sup>C Serial Interface (for a third-party Accelerometer)

The MPU-3050 has a secondary I<sup>2</sup>C bus for communicating to an off-chip 3-axis digital output accelerometer. This bus has two operating modes: I<sup>2</sup>C Master Mode, where the MPU-3050 acts as a master to an external accelerometer connected to the secondary I<sup>2</sup>C bus; and Pass-Through Mode, where the MPU-3050 directly connects the primary and secondary I<sup>2</sup>C buses together, to allow the system processor to directly communicate with the external accelerometer.

##### Secondary I<sup>2</sup>C Bus Modes of Operation:

- **I<sup>2</sup>C Master Mode:** allows the MPU-3050 to directly access the data registers of an external digital accelerometer. In this mode, the MPU-3050 directly obtains sensor data from accelerometers and optionally, another sensor (such as a magnetometer), thus allowing the on-chip DMP to generate sensor fusion data without intervention from the system applications processor. In I<sup>2</sup>C master mode, the MPU-3050 can be configured to perform burst reads, returning the following data from the accelerometer:
  - X accelerometer data (2 bytes)
  - Y accelerometer data (2 bytes)
  - Z accelerometer data (2 bytes)
- **Pass-Through Mode:** allows an external system processor to act as master and directly communicate to the external accelerometer connected to the secondary I<sup>2</sup>C bus pins (AUX\_DA and AUX\_CL). This is useful for configuring the accelerometers, or for keeping the MPU-3050 in a low-power mode, when only accelerometers are to be used. In this mode, the secondary I<sup>2</sup>C bus control logic (third-party accelerometer Interface block) of the MPU-3050 is disabled, and the secondary I<sup>2</sup>C pins AUX\_DA and AUX\_CL (Pins 6 and 7) are connected to the main I<sup>2</sup>C bus (Pins 23 and 24) through analog switches.

##### Secondary I<sup>2</sup>C Bus IO Logic Levels

The logic levels of the secondary I<sup>2</sup>C bus can be programmed to be either VDD or VLOGIC (see Sections 7 and 8).

## 6 Clocking

### 6.1 Internal Clock Generation

The MPU-3050 has a flexible clocking scheme, allowing for a variety of internal or external clock sources for the internal synchronous circuitry. This synchronous circuitry includes the signal conditioning and ADCs, the DMP, and various control circuits and registers. An on-chip PLL provides flexibility in the allowable inputs for generating this clock.

Allowable internal sources for generating the internal clock are:

- An internal relaxation oscillator
- Any of the X, Y, or Z gyros (MEMS oscillators with an accuracy of  $\pm 2\%$  over temperature)

Allowable external clocking sources are:

- 32.768 kHz square wave
- 19.2 MHz square wave

Which source to select for generating the internal synchronous clock depends on the availability of external sources and the requirements for power consumption and clock accuracy. Most likely, these requirements will vary by mode of operation. For example, in one mode, where the biggest concern is power consumption, one may wish to operate the Digital Motion Processor of the MPU-3050 to process accelerometer data, while keeping the gyros off. In this case, the internal relaxation oscillator is a good clock choice. However, in another mode, where the gyros are active, selecting the gyros as the clock source provides for a more accurate clock source.

Clock accuracy is important, since timing errors directly affect the distance and angle calculations performed by the Digital Motion Processor (or by extension, by any processor).

There are also start-up conditions to consider. When the MPU-3050 first starts up, the device operates off of its internal clock, until programmed to operate from another source. This allows the user, for example, to wait for the MEMS oscillators to stabilize before they are selected as the clock source.

### 6.2 Clock Output

In addition, the MPU-3050 provides a clock output, which allows the device to operate synchronously with an external digital 3-axis accelerometer. Operating synchronously provides for higher-quality sensor fusion data, since the sampling instant for the sensor data can be set to be coincident for all sensors.

### 6.3 Sensor Data Registers

The sensor data registers contain the latest gyro and temperature data. They are read-only registers, and are accessed via the Serial Interface. Data from these registers may be read anytime, however, the interrupt function may be used to determine when new data is available.

### 6.4 FIFO

The MPU-3050 contains a 512-byte FIFO register that is accessible via the Serial Interface. The FIFO configuration register determines what data goes into it, with possible choices being gyro data, accelerometer data, temperature readings, auxiliary ADC readings, and FSYNC input. A FIFO counter keeps track of how many bytes of valid data are contained in the FIFO. The FIFO register supports burst reads. The interrupt function may be used to determine when new data is available.

### 6.5 Interrupts

Interrupt functionality is configured via the Interrupt Configuration register. Items that are configurable include the INT pin configuration, the interrupt latching and clearing method, and triggers for the interrupt. Items that can trigger an interrupt are (1) Clock generator locked to new reference oscillator (used when switching clock sources); (2) Digital Motion Processor Done (programmable function); (3) new data is available to be read (from the FIFO and Data registers); and (4) the MPU-3050 did not receive an acknowledgment from the accelerometer on the Secondary I<sup>2</sup>C bus. The interrupt status can be read from the Interrupt Status register.

**6.6 Bias and LDO**

The bias and LDO section generates the internal supply and the reference voltages and currents required by the MPU-3050. Its two inputs are an unregulated VDD of 2.1 V to 3.6 V and a VLOGIC logic reference supply voltage of 1.71 V to VDD. The LDO output is bypassed by a 0.1  $\mu$ F capacitor at REGOUT.

**6.7 Charge Pump**

An on-board charge pump generates the high voltage required for the MEMS oscillators. Its output is bypassed by a 2.2 nF capacitor at CPOUT.

**6.8 Chip Version**

The chip version is written into OTP memory that is accessed using Register 1 (PRODUCT\_ID).

## 7 Digital Interface

### 7.1 I<sup>2</sup>C Serial Interface

The internal registers and memory of the MPU-3050 can be accessed using I<sup>2</sup>C.

#### Serial Interface

Pin Number	MPU-3050	Pin Name	Pin Description
8	Y	VLOGIC	Digital I/O supply voltage. VLOGIC must be $\leq$ VDD at all times.
9	Y	AD0	I <sup>2</sup> C Slave Address LSB
23	Y	SCL	I <sup>2</sup> C serial clock
24	Y	SDA	I <sup>2</sup> C serial data

#### 7.1.1 I<sup>2</sup>C Interface

I<sup>2</sup>C is a two-wire interface comprised of the signals serial data (SDA) and serial clock (SCL). In general, the lines are open-drain and bi-directional. In a generalized I<sup>2</sup>C interface implementation, attached devices can be a master or a slave. The master device puts the slave address on the bus, and the slave device with the matching address acknowledges the master.

The MPU-3050 always operates as a slave device when communicating to the system processor, which thus acts as the master. SDA and SCL lines typically need pull-up resistors to VDD. The maximum bus speed is 400 kHz.

The slave address of the MPU-3050 is b110100X which is 7 bits long. The LSB bit of the 7-bit address is determined by the logic level on pin AD0. This allows two MPU-3050s to be connected to the same I<sup>2</sup>C bus. When used in this configuration, the address of the one of the devices should be b1101000 (pin AD0 is logic low) and the address of the other should be b1101001 (pin AD0 is logic high). The I<sup>2</sup>C address is stored in register 0 (WHO\_AM\_I register).

#### I<sup>2</sup>C Communications Protocol

##### START (S) and STOP (P) Conditions

Communication on the I<sup>2</sup>C bus starts when the master puts the START condition (S) on the bus, which is defined as a HIGH-to-LOW transition of the SDA line while SCL line is HIGH (see figure below). The bus is considered to be busy until the master puts a STOP condition (P) on the bus, which is defined as a LOW to HIGH transition on the SDA line while SCL is HIGH (see figure below).

Additionally, the bus remains busy if a repeated START (Sr) is generated instead of a STOP condition.

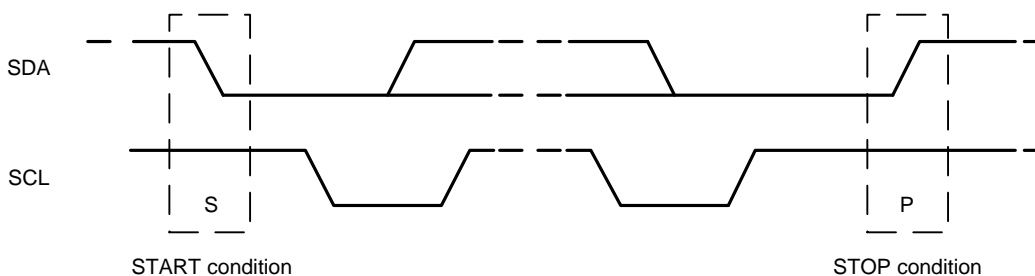

**START and STOP Conditions**

Data Format / Acknowledge

I<sup>2</sup>C data bytes are defined to be 8 bits long. There is no restriction to the number of bytes transmitted per data transfer. Each byte transferred must be followed by an acknowledge (ACK) signal. The clock for the acknowledge signal is generated by the master, while the receiver generates the actual acknowledge signal by pulling down SDA and holding it low during the HIGH portion of the acknowledge clock pulse.

If a slave is busy and cannot transmit or receive another byte of data until some other task has been performed, it can hold SCL LOW, thus forcing the master into a wait state. Normal data transfer resumes when the slave is ready, and releases the clock line (refer to the following figure).

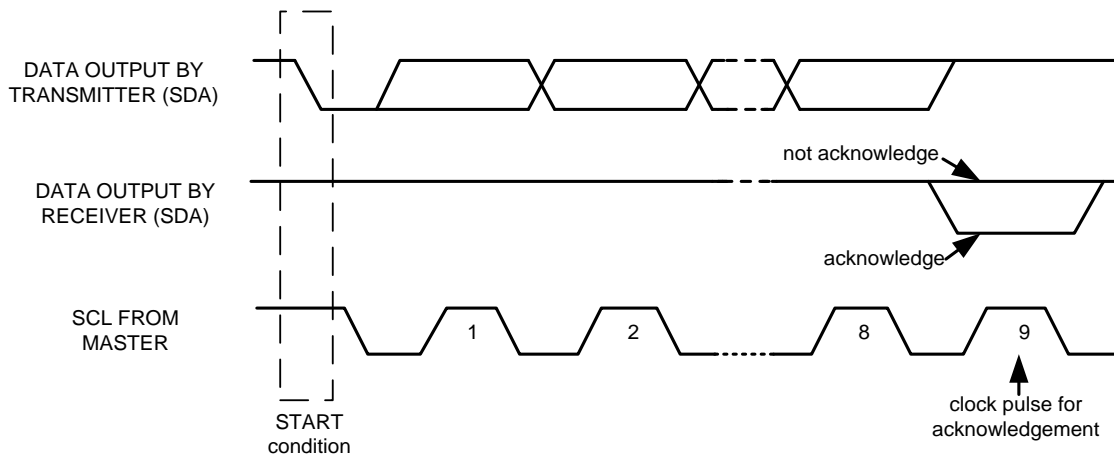

**Acknowledge on the I<sup>2</sup>C Bus**

Communications

After beginning communications with the START condition (S), the master sends a 7-bit slave address followed by an 8<sup>th</sup> bit, the read/write bit. The read/write bit indicates whether the master is receiving data from or is writing to the slave device. Then, the master releases the SDA line and waits for the acknowledge signal (ACK) from the slave device. Each byte transferred must be followed by an acknowledge bit. To acknowledge, the slave device pulls the SDA line LOW and keeps it LOW for the high period of the SCL line. Data transmission is always terminated by the master with a STOP condition (P), thus freeing the communications line. However, the master can generate a repeated START condition (Sr), and address another slave without first generating a STOP condition (P). A LOW to HIGH transition on the SDA line while SCL is HIGH defines the stop condition. All SDA changes should take place when SCL is low, with the exception of start and stop conditions.

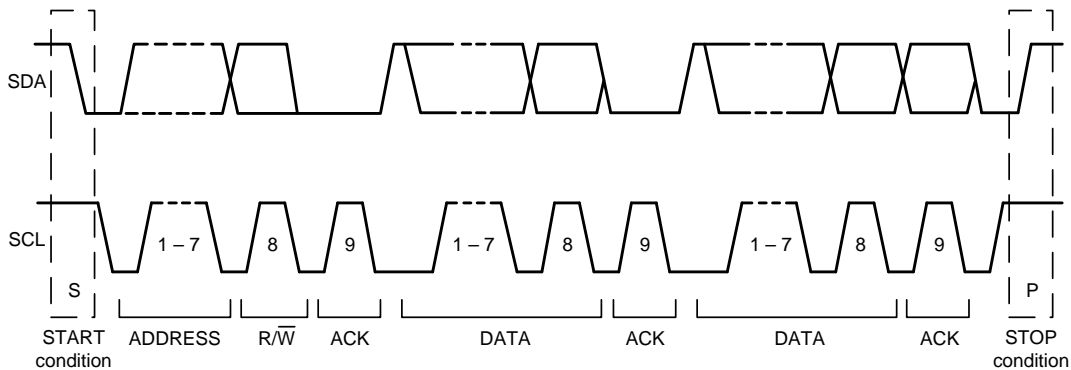

**Complete I<sup>2</sup>C Data Transfer**

To write the internal MPU-3050 registers, the master transmits the start condition (S), followed by the I<sup>2</sup>C address and the write bit (0). At the 9<sup>th</sup> clock cycle (when the clock is high), the MPU-3050 acknowledges the transfer. Then the master puts the register address (RA) on the bus. After the MPU-3050 acknowledges the reception of the register address, the master puts the register data onto the bus. This is followed by the ACK signal, and data transfer may be concluded by the stop condition (P). To write multiple bytes after the last ACK signal, the master can continue outputting data rather than transmitting a stop signal. In this case, the MPU-3050 automatically increments the register address and loads the data to the appropriate register. The following figures show single and two-byte write sequences.

**Single-Byte Write Sequence**

Master	S	AD+W		RA		DATA		P
Slave			ACK		ACK		ACK	

**Burst Write Sequence**

Master	S	AD+W		RA		DATA		DATA		P
Slave			ACK		ACK		ACK		ACK	

To read the internal MPU-3050 registers, the master sends a start condition, followed by the I<sup>2</sup>C address and a write bit, and then the register address that is going to be read. Upon receiving the ACK signal from the MPU-3050, the master transmits a start signal followed by the slave address and read bit. As a result, the MPU-3050 sends an ACK signal and the data. The communication ends with a not acknowledge (NACK) signal and a stop bit from master. The NACK condition is defined such that the SDA line remains high at the 9<sup>th</sup> clock cycle. The following figures show single and two-byte read sequences.

**Single-Byte Read Sequence**

Master	S	AD+W		RA		S	AD+R			NACK	P
Slave			ACK		ACK			ACK	DATA		

**Burst Read Sequence**

Master	S	AD+W		RA		S	AD+R			ACK		NACK	P
Slave			ACK		ACK			ACK	DATA		DATA		

**I<sup>2</sup>C Terms**

<b>Signal</b>	<b>Description</b>
S	Start Condition: SDA goes from high to low while SCL is high
AD	Slave I <sup>2</sup> C address
W	Write bit (0)
R	Read bit (1)
ACK	Acknowledge: SDA line is low while the SCL line is high at the 9 <sup>th</sup> clock cycle
NACK	Not-Acknowledge: SDA line stays high at the 9 <sup>th</sup> clock cycle
RA	MPU-3050 internal register address
DATA	Transmit or received data
P	Stop condition: SDA going from low to high while SCL is high

**8 Serial Interface Considerations (MPU-3050)**

**8.1 MPU-3050 Supported Interfaces**

The MPU-3050 supports I<sup>2</sup>C communications on both its primary (microprocessor) serial interface and its secondary (accelerometer) interface.

**8.2 Logic Levels**

The MPU-3050 I/O logic levels are set to be either VDD or VLOGIC, as shown in the table below.

**I/O Logic Levels vs. *AUX\_VDDIO* (bit 2, Register 19 – Accelerometer Burst Read Address)**

<i>AUX_VDDIO</i>	<b>MICROPROCESSOR LOGIC LEVELS</b> (Pins: SDA, SCL, AD0,CLKIN, INT)	<b>ACCELEROMETER LOGIC LEVELS</b> (Pins: AUX_DA, AUX_CL)
0	VLOGIC	VLOGIC
1	VLOGIC	VDD

Notes:

1. CLKOUT has logic levels that are always referenced to VDD.
2. The power-on-reset value for *AUX\_VDDIO* is 0.

VLOGIC may be set to be equal to VDD or to another voltage, such that at all times VLOGIC is ≤ VDD. When *AUX\_VDDIO* is set to 0 (its power-on-reset value), VLOGIC is the power supply voltage for both the microprocessor system bus and the accelerometer secondary bus, as shown in the figure of Section 8.2.1.

When *AUX\_VDDIO* is set to 1, VLOGIC is the power supply voltage for the microprocessor system bus and VDD is the supply for the accelerometer secondary bus, as shown in the figure of Section 8.2.2.

**8.2.1 AUX\_VDDIO = 0**

The figure below shows logic levels and voltage connections for AUX\_VDDIO = 0. Note: Actual configuration will depend on the type of third-party accelerometer used.

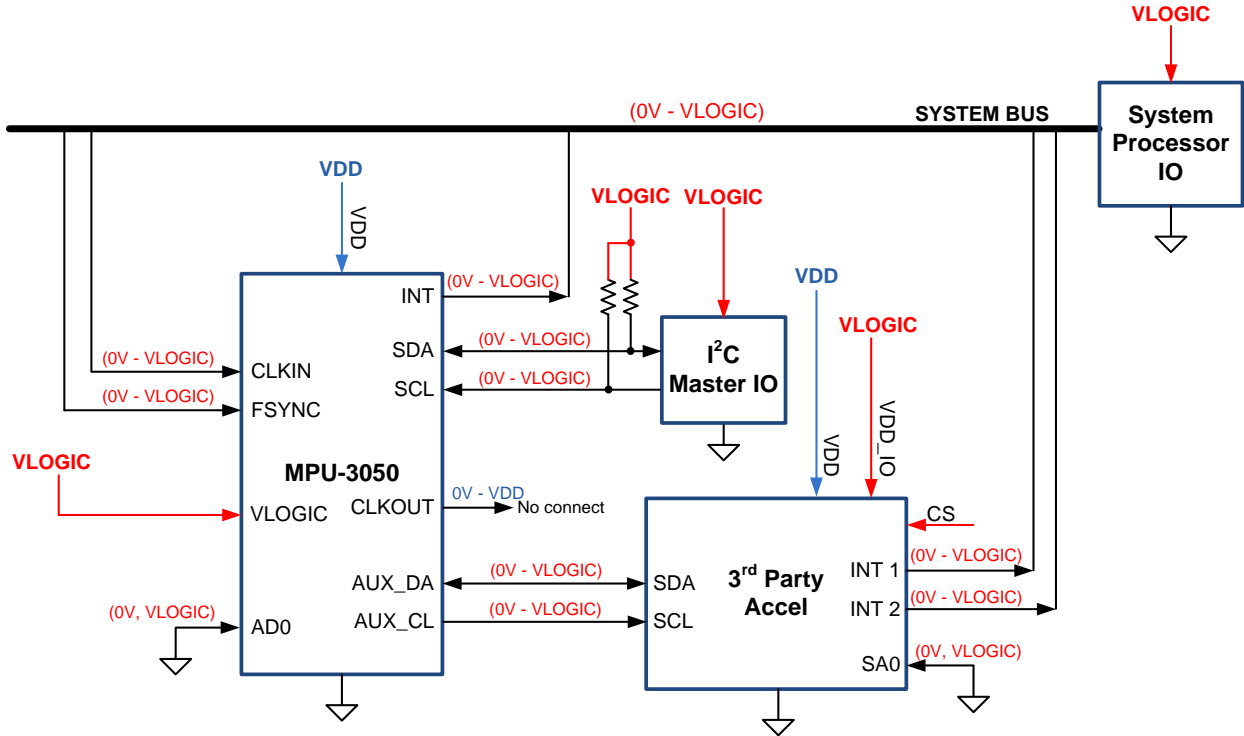

**Notes:**

1. AUX\_VDDIO is bit 7 in Register 24, and determines the IO voltage levels of AUX\_DA and AUX\_CL (0 = set output levels relative to VLOGIC)
2. CLKOUT is always referenced to VDD
3. Other MPU-3050 logic IO are always referenced to VLOGIC

**I/O Levels and Connections for AUX\_VDDIO = 0**



## 9 Motion Processing Library (MPL)

To assist in the rapid development and deployment of products using the MPU-3050, InvenSense provides a Motion Processing Library (MPL) file that has been compiled to work the hardware and software environment specific to InvenSense devices.

The MPL contains the core algorithm engines for motion processing, and includes an API layer which provides a simple interface into using these engines (see figure below).

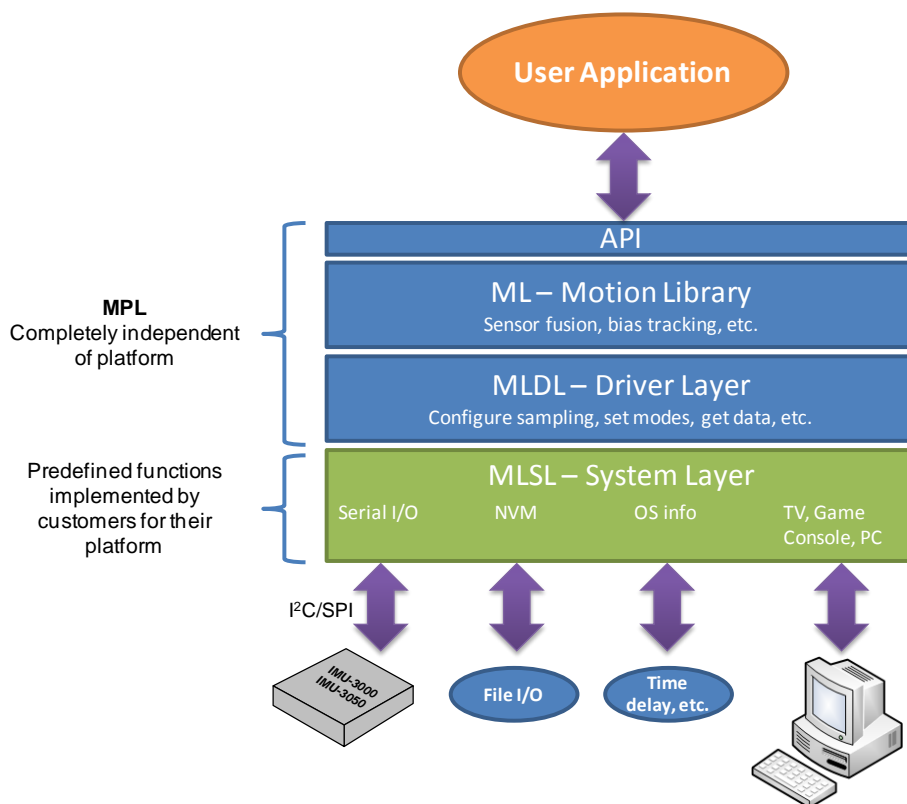

**MPL Interfacing with Hardware Devices and Application Level**

The MPL communicates with the System Layer, which is a platform-specific interface into the hardware and software environment; this System Layer software must be implemented by the customer – for his particular environment. InvenSense provides shell functions to speed up the development of this System Layer software. The MPL is independent of the Operating System (OS) since the System Layer software handles OS-specific requirements.

The purpose of the DMP is to offload both timing requirements and processing power from the host processor. Typically, raw data integration (sensor fusion) should be run at a high rate, often around 200Hz, in order to provide accurate results with low latency. This is required even if the application updates at a much lower rate; for example, a low power user interface may update as slowly as 5Hz, but the sensor fusion should still run at 200Hz. The DMP can be used as a tool in order to minimize power, simplify timing and software architecture, and save valuable MIPS on the host processor for use in the application.

A complementary software guide, MPU-3000 MPL Functional Specification Version 1.0, describes in detail the API and System Layer routines needed for interfacing to the MPU-3050.

**9.1 Demo Software**

InvenSense provides demonstration software that runs on a PC running Windows XP. This software works in conjunction with the hardware shown in the figure shown above. The PC demo software provides the functionality that allows a user to become familiar with the use of gyros and accelerometers.

**10 Assembly**

This section provides general guidelines for assembling InvenSense Micro Electro-Mechanical Systems (MEMS) devices packaged in QFN package.

The following six best practices will ensure higher quality in assembly.

1. Do not leave parts out of the original moisture-sealed bags for more than 48 hours before assembly
2. Do not solder the center pad
3. Do not place large insertion components, such as buttons, switches, connectors, or shielding boxes at a distance of less than 6 mm from the MEMS gyro
4. Do use Electrostatic Discharge (ESD) protection at or better than 200V, preferably 150V, to prevent Machine Model (MM) type ESD damage
5. Do use ESD protection measures to ensure that personnel prevent Human Body Model (HBM) type ESD damage
6. Do not mechanically impact or shock the package in any of the production processes

**10.1 Orientation**

The diagram below shows the orientation of the axes of sensitivity and the polarity of rotation.

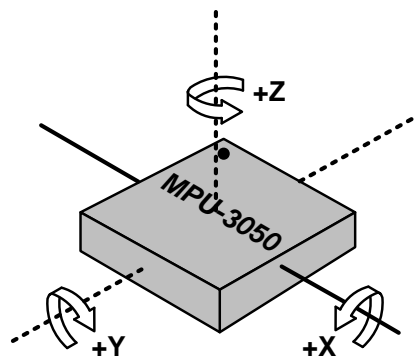

**Orientation of Axes of Sensitivity and Polarity of Rotation**

**10.2 PCB Layout Guidelines**

**10.2.1 Package Dimensions**

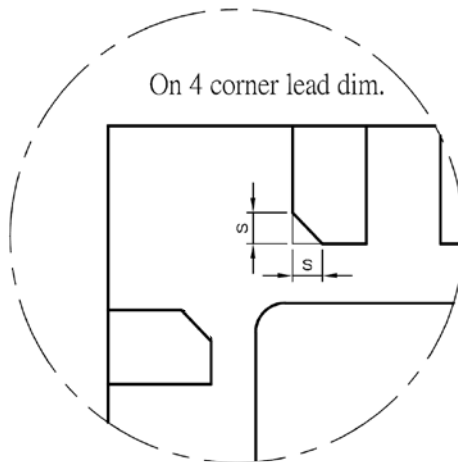
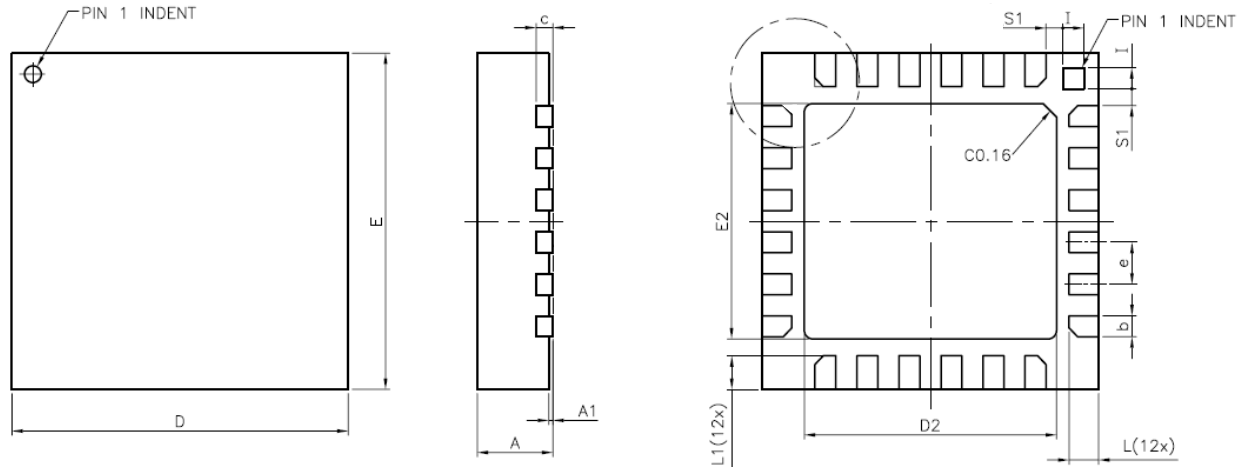

NOTE:  
1. THE TERMINAL #1 IDENTIFIER IS A LASER MARKED FEATURE

SYMBOLS	DIMENSIONS IN MILLIMETERS		
	MIN	NOM	MAX
A	0.85	0.90	0.95
A1	0.00	0.02	0.05
b	0.18	0.25	0.30
c	—	0.20 REF.	—
D	3.90	4.00	4.10
D2	2.95	3.00	3.05
E	3.90	4.00	4.10
E2	2.75	2.80	2.85
e	—	0.50	—
L	0.30	0.35	0.40
L1	0.35	0.40	0.45
I	0.20	0.25	0.30
s	0.05	—	0.15
S1	0.15	0.20	0.25

**10.2.2 PCB Design Guidelines:**

The Pad Diagram is shown in Figure 2 using a JEDEC type extension with solder rising on the outer edge. The Pad Dimensions Table shows pad sizing (mean dimensions) for the MPU-3050 product.

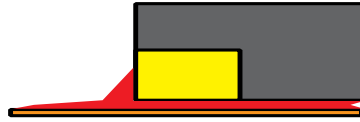

JEDEC type extension with solder rising on outer edge

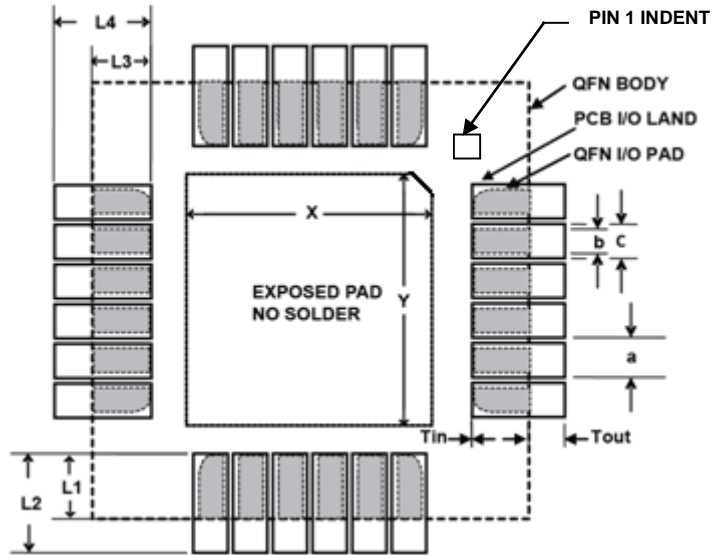

**Pad Diagram**

Nominal Package I/O Pad Dimensions (mm)	
Pad Pitch (a)	0.50
Pad Width (b)	0.30
Pad Length (L1)	0.40
Pad Length (L3)	0.35
Exposed Pad Width (X)	2.80
Exposed Pad Length (Y)	3.00
I/O Land Design Dimensions Guidelines (mm)	
Land Width (c)	0.35
Outward Extension (Tout)	0.40
Inward Extension (Tin)	0.05
Land Length (L2)	0.80
Land Length (L4)	0.75

**Pad Dimensions Table**

InvenSense MEMS Gyros sense rate of rotation. In addition, gyroscopes sense mechanical stress coming from the PCB. This PCB stress is minimized with simple design rules:

1. Component Placement – Testing indicates that there are no specific design considerations other than generally accepted industry design practices for component placement near the MPU-3050 gyroscope to prevent noise coupling and thermo-mechanical stress.
2. The area below the MEMS gyro (on the same side of the board) must be defined as a keep-out area. It is strongly recommended to not place any structure in top metal layer underneath the keep-out area.
3. Traces connected to pads should be as much symmetric as possible. Symmetry and balance for pad connection will help component self-alignment and will lead to better control of solder paste reduction after reflow.
4. Testing indicates that 3-Volt peak-to-peak signals run under the gyro package or directly on top of the package of frequencies from DC to 1MHz do not affect the operation of the MEMS gyro. However, routing traces or vias under the MEMS gyro package such that they run under the exposed die pad is prohibited.
5. To achieve best performance over temperature and to prevent thermo-mechanical package stress, do not place large insertion components like buttons, connectors, or shielding boxes at a distance of less than 6 mm from the MEMS gyro.

### 10.2.3 Exposed Die Pad Precautions

The MPU-3050 has very low active and standby current consumption. The exposed die pad is not required for heat sinking, and should not be soldered to the PCB since soldering to it contributes to performance changes due to package thermo-mechanical stress. There is no electrical connection between the pad and the CMOS.

### 10.2.4 Gyro Removal from PCB

Never apply high mechanical force while removing MEMS gyros from PCB. Otherwise, the QFN package leads can be removed and failure analysis of the gyro unit will be impossible. Tweezers are practical. Do not apply a pulling force upward. Instead apply a gentle force sideward while heating. When sufficient heat has been applied, the unit will start to slide sideways and can now be pulled gently upwards with the tweezers.

In any case, mechanical or thermo-mechanical overstress during manual handling and soldering, (especially contact between the soldering iron or hot air gun and the package) has to be avoided.

If safe removal of the suspected component is not possible or deemed too risky, send the whole PCB or the part of the PCB containing the defective component back to InvenSense. If requested, we will return the PCB after we have removed the gyro.

## 10.3 Trace Routing

Testing indicates that 3-Volt peak-to-peak signals run under the gyro package or directly on top of the package of frequencies from DC to 1 MHz do not affect the operation of the MEMS gyro. However, routing traces or vias under the MEMS gyro package such that they run under the exposed die pad is prohibited.

## 10.4 Component Placement

Do not place large insertion components such as keyboard or similar buttons, connectors, or shielding boxes at a distance of less than 6 mm from the MEMS gyro. Maintain generally accepted industry design practices for component placement near the MPU-3050 to prevent noise coupling and thermo-mechanical stress.

**10.5 PCB Mounting and Cross-Axis Sensitivity**

Orientation errors of the gyroscope mounted to the printed circuit board can cause cross-axis sensitivity in which one gyro responds to rotation about another axis, for example, the X-axis gyroscope responding to rotation about the Y or Z axes. The orientation mounting errors are illustrated in the figure below.

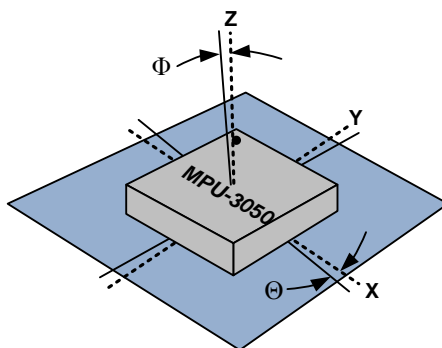

**Package Gyro Axes ( ..... ) Relative to PCB Axes ( — ) with Orientation Errors ( $\Theta$  and  $\Phi$ )**

The table below shows the cross-axis sensitivity as a percentage of the specified gyroscope's sensitivity for a given orientation error.

**Cross-Axis Sensitivity vs. Orientation Error**

Orientation Error ( $\theta$ or $\Phi$ )	Cross-Axis Sensitivity ( $\sin\theta$ or $\sin\Phi$ )
0°	0%
0.5°	0.87%
1°	1.75%

The specification for cross-axis sensitivity in Section 3 includes the effect of the die orientation error with respect to the package.

**10.6 Package Marking Specification**

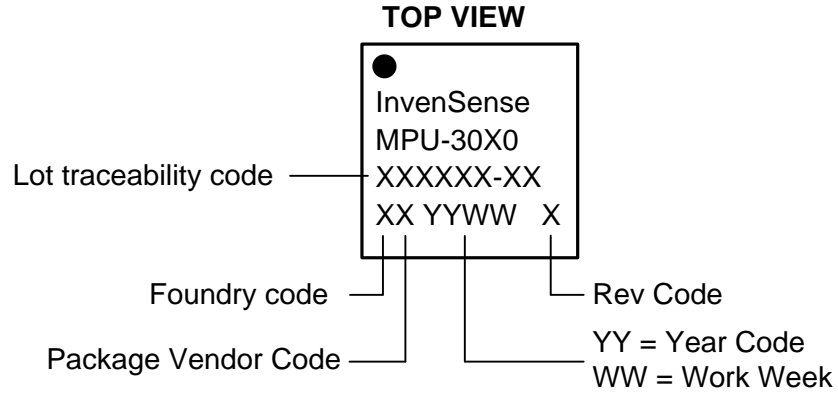

**Package Marking Specification**

**11 Register Map**

Addr (Hex)	Addr (Decimal)	Register Name	R/W	Bit7	Bit6	Bit5	Bit4	Bit3	Bit2	Bit1	Bit0
0	0	WHO_AM_I	R/W	I2C_IF_DIS	ID						-
1	1	PRODUCT_ID	R/W	PART_NUM				VERSION			
C	12	X_OFFS_USRH	R/W	X_OFF_H							
D	13	X_OFFS_USRL	R/W	X_OFF_L							
E	14	Y_OFFS_USRH	R/W	Y_OFFS_H							
F	15	Y_OFFS_USRL	R/W	Y_OFFS_L							
10	16	Z_OFFS_USRH	R/W	Z_OFFS_H							
11	17	Z_OFFS_USRL	R/W	Z_OFFS_L							
12	18	FIFO_EN	R/W	TEMP_OUT	GYRO_XOUT	GYRO_YOUT	GYRO_ZOUT	AUX_XOUT	AUX_YOUT	AUX_ZOUT	FIFO_FOOTER
13	19	AUX_VDDIO	R/W	0	0	0	0	0	AUX_VDDIO	0	0
14	20	AUX_SLV_ADDR	R/W	CLKOUT_EN	AUX_ID						
15	21	SMPLRT_DIV	R/W	SMPLRT_DIV							
16	22	DLPF_FS_SYNC	R/W	EXT_SYNC_SET			FS_SEL		DLPF_CFG		
17	23	INT_CFG	R/W	ACTL	OPEN	LATCH_INT_EN	INT_ANYRD_2CLEAR	-	MPU_RDY_EN	DMP_DONE_EN	RAW_RDY_EN
18	24	AUX_ADDR	R/W	BURST_ADDR							
1A	26	INT_STATUS	R	-	-	-	-	-	MPU_RDY	DMP_DONE	RAW_DATA_RDY
1D	29	GYRO_XOUT_H	R	GYRO_XOUT_H							
1E	30	GYRO_XOUT_L	R	GYRO_XOUT_L							
1F	31	GYRO_YOUT_H	R	GYRO_YOUT_H							
20	32	GYRO_YOUT_L	R	GYRO_YOUT_L							
21	33	GYRO_ZOUT_H	R	GYRO_ZOUT_H							
22	34	GYRO_ZOUT_L	R	GYRO_ZOUT_L							
23	35	AUX_XOUT_H	R	AUX_XOUT_H							
24	36	AUX_XOUT_L	R	AUX_XOUT_L							
25	37	AUX_YOUT_H	R	AUX_YOUT_H							
26	38	AUX_YOUT_L	R	AUX_YOUT_L							
27	39	AUX_ZOUT_H	R	AUX_ZOUT_H							
28	40	AUX_ZOUT_L	R	AUX_ZOUT_L							
3A	58	FIFO_COUNTH	R	-	-	-	-	-	-	-	FIFO_COUNT_H
3B	59	FIFO_COUNTL	R	FIFO_COUNT_L							
3C	60	FIFO_R	R	FIFO_DATA							
3D	61	USER_CTRL	R/W	-	FIFO_EN	AUX_IF_EN	-	AUX_IF_RST	-	FIFO_RST	GYRO_RST
3E	62	PWR_MGM	R/W	H_RESET	SLEEP	STBY_XG	STBY_YG	STBY_ZG	CLK_SEL		

## 12 Register Description

This section details each register within the InvenSense MPU-30X0 gyroscope. Note that any bit that is not defined should be set to zero in order to be compatible with future InvenSense devices.

The register space allows single-byte reads and writes, as well as burst reads and writes. When performing burst reads or writes, the memory pointer will increment until either (1) reading or writing is terminated by the master, or (2) the memory pointer reaches an indirect-read or indirect read/write register (registers 57 and 60).

### 12.1 Register 0 – Who Am I

**Type: Read/Write**

Register (Hex)	Register (Decimal)	Bit7	Bit6	Bit5	Bit4	Bit3	Bit2	Bit1	Bit0	Default Value	
0	0	I2C_IF_DIS	ID							-	68 h

**Description:**

This register is used to verify the identity of the device, and to enable/disable the I<sup>2</sup>C interface.

**Parameters:**

*I2C\_IF\_DIS*      Setting this bit disables I<sup>2</sup>C access mode.

*ID*                      Contains the I<sup>2</sup>C address of the device, which can also be changed by writing to this register.

The Power-On-Reset value of Bit6: Bit1 is 110 100.

**12.2 Register 01 – Product ID**

**Type: Read/Write**

Register (Hex)	Register (Decimal)	Bit7	Bit6	Bit5	Bit4	Bit3	Bit2	Bit1	Bit0
1	1	PART_NUM				VERSION			

**Description:**

This register is used to read the part number and silicon version of the MPU-3050. The *PART\_NUM* parameter lists the part number for the device, and its value is interpreted as follows:

**PART\_NUM**

PART_NUM	Device Part Number
0	Reserved
1	MPU-3000
2	Reserved
3	MPU-3050
4	Reserved
5	Reserved
6	Reserved
7	Reserved
8	Reserved
9	Reserved
10	Reserved
11	Reserved
12	Reserved
13	Reserved
14	Reserved
15	Reserved

The *VERSION* parameter lists the silicon version for the device, and its value is interpreted as follows:

**VERSION**

VERSION	Part Package Label	Description
0	n/a	Reserved
1	n/a	Reserved
2	n/a	Reserved
3	n/a	Reserved
4	n/a	Reserved
5	n/a	Reserved
6	n/a	Reserved
7	MPU-3000/3050 (G)	All-layer CMOS change – preproduction units
8	MPU-3000/3050 (G)	Trim update
9		
10		
11	MPU-3000/3050 (J)	CMOS metal change
12	MPU-3000/3050 (J)	Trim Update
13		
14	MPU-3000/3050 (K)	Changed auxiliary slave addressing scheme to 8-bit; relocated auxiliary interface voltage selection bit accordingly.
15		

n/a = not applicable

**Parameters:**

*PART\_NUM* Part number  
*VERSION* Part version

**12.3 Registers 12 to 17 – Gyro Offsets**

**Type: Read/Write**

Register (Hex)	Register (Decimal)	Bit7	Bit6	Bit5	Bit4	Bit3	Bit2	Bit1	Bit0
C	12	X_OFFSETS_H							
D	13	X_OFFSETS_L							
E	14	Y_OFFSETS_H							
F	15	Y_OFFSETS_L							
10	16	Z_OFFSETS_H							
11	17	Z_OFFSETS_L							

**Description:**

These registers are used to remove DC bias from the sensor outputs. The values in these registers are subtracted from the gyro sensor values before going into the sensor registers (see registers 27 to 34).

**Parameters:**

*X\_OFFSETS\_H/L* 16-bit offset (high and low bytes) of X gyro offset (2's complement)  
*Y\_OFFSETS\_H/L* 16-bit offset (high and low bytes) of Y gyro offset (2's complement)  
*Z\_OFFSETS\_H/L* 16-bit offset (high and low bytes) of Z gyro offset (2's complement)

**12.4 Register 18 – FIFO Enable**

**Type: Read/Write**

Register (Hex)	Register (Decimal)	Bit7	Bit6	Bit5	Bit4	Bit3	Bit2	Bit1	Bit0	Default Value
12	18	-	GYRO_XOUT	GYRO_YOUT	GYRO_ZOUT	AUX_XOUT	AUX_YOUT	AUX_ZOUT	FIFO_FOOTER	00h

**Description:**

This register determines what data goes into the MPU-3050 FIFO, which is a 512-byte First-In-First-Out buffer (see register 60). Sensor data is automatically placed into the FIFO after each ADC sampling period is complete. The ADC sample rate is controlled by register 21.

The order at which the data is put into the FIFO is from MSB to LSB, which means that it will match the order shown in the parameter detail below. Two bytes are used for each reading. For example, if Gyro X, Gyro Y, Gyro Z, and FIFO\_FOOTER are configured to go into the FIFO, then each sample period the following 8 bytes would be inserted into the FIFO, as shown below:

Gyro X high byte	Gyro X low byte	Gyro Y high byte	Gyro Y low byte	Gyro Z high byte	Gyro Z low byte	FIFO_FOOTER High byte	FIFO_FOOTER Low byte
------------------	-----------------	------------------	-----------------	------------------	-----------------	-----------------------	----------------------

**Parameters:**

<i>GYRO_XOUT</i>	Setting this inserts the X Gyro reading into FIFO
<i>GYRO_YOUT</i>	Setting this inserts the Y Gyro reading into FIFO
<i>GYRO_ZOUT</i>	Setting this inserts the Z Gyro reading into FIFO
<i>AUX_XOUT</i>	Setting this inserts the X Accelerometer reading into FIFO
<i>AUX_YOUT</i>	Setting this inserts the Y Accelerometer reading into FIFO
<i>AUX_ZOUT</i>	Setting this inserts the Z Accelerometer reading into FIFO
<i>FIFO_FOOTER</i>	Last word (2 bytes) for FIFO read. Described in more detail in register 60

**12.5 Register 19 – AUX (Accel) VDDIO**

**Type: Read/Write**

Register (Hex)	Register (Decimal)	Bit7	Bit6	Bit5	Bit4	Bit3	Bit2	Bit1	Bit0	Default Value
13	19	0	0	0	0	0	AUX_VDDIO	0	0	00h

**Description:**

This register determines the I/O logic levels for the secondary I<sup>2</sup>C bus clock and data lines (AUX\_CL, AUX\_DA). 1=VDD, 0=VLOGIC.

**Parameters:**

<i>AUX_VDDIO</i>	I/O logic levels for the secondary I <sup>2</sup> C bus clock and data lines (AUX_CL, AUX_DA). 1=VDD, 0=VLOGIC.
0	Load zeros into Bits 0, 1, 3-7.

**12.6 Register 20 – AUX (Accel) Slave Address**

**Type: Read/Write**

Register (Hex)	Register (Decimal)	Bit7	Bit6	Bit5	Bit4	Bit3	Bit2	Bit1	Bit0	Default value
14	20	CLKOUT_EN	AUX_ID							00h

**Description:**

This register contains the 7-bit slave address of the external accelerometer device. This address is used to access the accel device so that its sensor reading can be automatically read during each sample period at the same time as the gyro sensors.

When reading the accel sensor registers, the MPU-3050 takes over the secondary I<sup>2</sup>C bus, as a master to the accel device, performing a burst read of the sensor registers. For this interface to be active, the *AUX\_IF\_EN* flag in the User Control register (61) must be cleared (set to 0).

Whenever changing this register, the accel interface must be reset to take effect. Refer to the User Control register (61).

**Parameters:**

- AUX\_ID* Contains the I<sup>2</sup>C address of the device, which can also be changed by writing to this register.
- CLKOUT\_EN* 1 – Reference clock output is provided at CLKOUT pin.  
0 – Function is disabled.

**12.7 Register 21 – Sample Rate Divider**

**Type: Read/Write**

Register (Hex)	Register (Decimal)	Bit7	Bit6	Bit5	Bit4	Bit3	Bit2	Bit1	Bit0	Default Value
15	21	SMPLRT_DIV								00h

**Description:**

This register determines the sample rate of the MPU-3050 gyros. The analog gyros are sampled internally at either 1 kHz or 8 kHz, determined by the *DLPF\_CFG* setting (see register 22). This sampling is then filtered digitally and delivered into the sensor registers after the number of cycles determined by this register. The sample rate is given by the following formula:

$$F_{\text{sample}} = F_{\text{internal}} / (\text{divider} + 1), \text{ where } F_{\text{internal}} \text{ is either } 1 \text{ kHz or } 8 \text{ kHz}$$

As an example, if the internal sampling is at 1 kHz, then setting this register to 7 would give the following:

$$F_{\text{sample}} = 1 \text{ kHz} / (7 + 1) = 125 \text{ Hz, or } 8 \text{ ms per sample}$$

**Parameters:**

- SMPLRT\_DIV* Sample rate divider: 0 to 255

**12.8 Register 22 – DLPF, Full Scale, External Sync**

**Type: Read/Write**

Register (Hex)	Register (Decimal)	Bit7	Bit6	Bit5	Bit4	Bit3	Bit2	Bit1	Bit0	Default Value
16	22	EXT_SYNC_SET			FS_SEL		DLPF_CFG			00h

**Description:**

This register configures several parameters related to the sensor acquisition.

The *EXT\_SYNC\_SET* parameter allows capturing the state of the external frame synchronization input pin (FSYNC, pin 11). The value of this input can be inserted into the LSB of one of the sensor registers. The register chosen is as follows:

**EXT\_SYNC\_SET**

EXT_SYNC_SET	Register
0	No sync (default)
1	TEMP_OUT_L[0]
2	GYRO_XOUT_L[0]
3	GYRO_YOUT_L[0]
4	GYRO_ZOUT_L[0]
5	AUX_XOUT_L[0]
6	AUX_YOUT_L[0]
7	AUX_ZOUT_L[0]

The *FS\_SEL* parameter allows setting the full-scale range of the gyro sensors, as described in the table below.

**FS\_SEL**

FS_SEL	Gyro Full-Scale Range
0	±250°/sec
1	±500°/sec
2	±1000°/sec
3	±2000°/sec

The *DLPF\_CFG* parameter sets the digital low pass filter configuration. It also determines the internal analog sampling rate used by the device as shown in the table below.

**DLPF\_CFG**

DLPF_CFG	Low Pass Filter Bandwidth	Analog Sample Rate
0	256Hz	8kHz
1	188Hz	1kHz
2	98Hz	1kHz
3	42Hz	1kHz
4	20Hz	1kHz
5	10Hz	1kHz
6	5Hz	1kHz

**Parameters:**

*EXT\_SYNC\_SET* Routing for the external frame synchronization input bit

*FS\_SEL* Full scale selection for gyro sensor data

*DLPF\_CFG* Digital low pass filter configuration

**DLPF Characteristics:** The gain and phase responses of the digital low pass filter settings (*DLPF\_CFG*) are shown below:

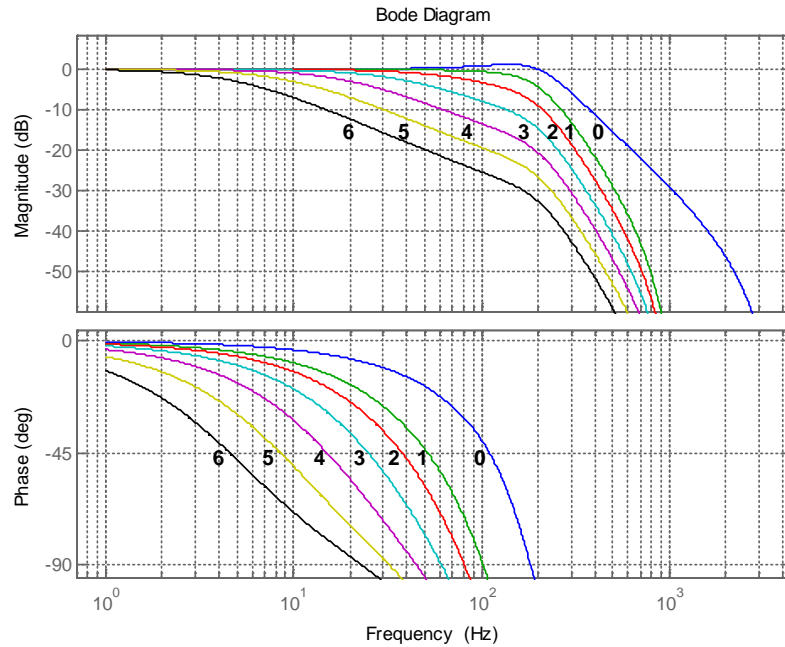

**Gain and Phase vs. Digital Filter Setting**

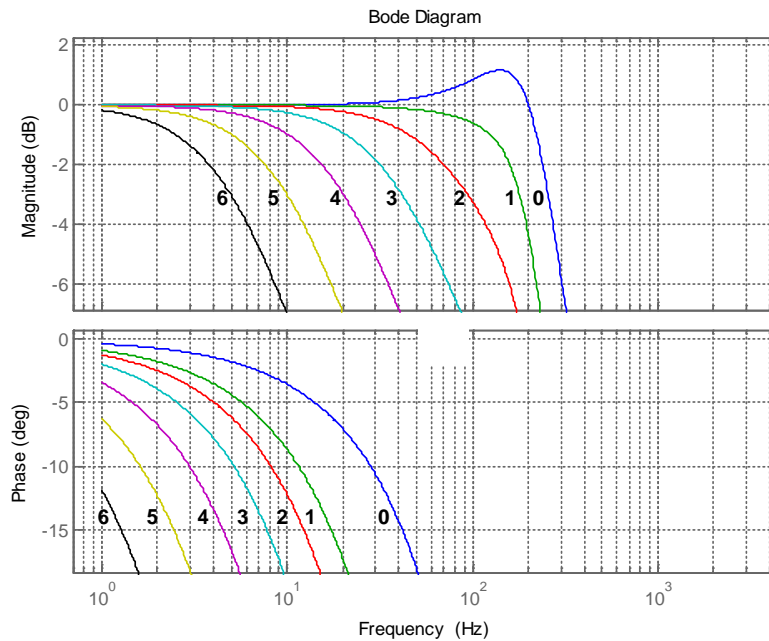

**Gain and Phase vs. Digital Filter Setting, Showing Passband Details**

**12.9 Register 23 – Interrupt Configuration**

**Type: Read/Write**

Register (Hex)	Register (Decimal)	Bit7	Bit6	Bit5	Bit4	Bit3	Bit2	Bit1	Bit0	Default Value
17	23	ACTL	OPEN	LATCH_INT_EN	INT_ANYRD_2CLEAR	-	MPU_RDY_EN	DMP_DONE_EN	RAW_RDY_EN	00h

**Description:**

This register configures the interrupt operation of the MPU-3050. The interrupt output pin (INT) configuration can be set, the interrupt latching/clearing method can be set, and the triggers for the interrupt can be set. If LATCH\_INT\_EN = 1, the INT pin is held active until the interrupt status register is cleared.

Note that if the application requires reading every sample of data from the MPU-3050, it is best to enable the raw data ready interrupt (RAW\_RDY\_EN). This allows the application to know when new sample data is available.

**Parameters:**

- ACTL* Logic level for INT output pin – 1=active low, 0=active high
- OPEN* Drive type for INT output pin – 1=open drain, 0=push-pull
- LATCH\_INT\_EN* Latch mode – 1=latch until interrupt is cleared, 0=50us pulse
- INT\_ANYRD\_2CLEAR* Interrupt status register clear method – 1=clear by reading any register, 0=clear by reading interrupt status register (26) only
- MPU\_RDY\_EN* Enable interrupt when device is ready (PLL ready after changing clock source)
- DMP\_DONE\_EN* Enable interrupt when DMP is done (programmable functionality)
- RAW\_RDY\_EN* Enable interrupt when data is available

**12.10 Register 24 – AUX (Accel) Burst Read Address**

**Type: Read only**

Register (Hex)	Register (Decimal)	Bit7	Bit6	Bit5	Bit4	Bit3	Bit2	Bit1	Bit0	Default Value
18	24	BURST_ADDR								00h

**Description:**

This register configures the burst-mode-read starting address for an accelerometer attached to the secondary I<sup>2</sup>C bus of the MPU-3000/3050.

**Parameters:**

- BURST\_ADDR* Burst-mode read starting address for external accelerometer attached to secondary I<sup>2</sup>C bus of the MPU-3000/3050. This is the starting address of the accelerometer which the MPU could use to read from.

**12.11 Register 26 – Interrupt Status**

**Type: Read only**

Register (Hex)	Register (Decimal)	Bit7	Bit6	Bit5	Bit4	Bit3	Bit2	Bit1	Bit0	Default Value
1A	26	-	-	-	-	-	MPU_RDY	DMP_DONE	RAW_DATA_RDY	00h

**Description:**

This register is used to determine the status of the MPU-3050 interrupt. Whenever one of the interrupt sources is triggered, the corresponding bit will be set. The polarity of the interrupt pin (active high/low) and the latch type (pulse or latch) has no effect on these status bits.

In normal use, the *RAW\_DATA\_RDY* interrupt is used to determine when new sensor data is available in either the sensor registers (27 to 34) or in the FIFO (60).

Interrupt Status bits get cleared as determined by *INT\_ANYRD\_2CLEAR* in the interrupt configuration register (23).

**Parameters:**

- MPU\_RDY* PLL ready
- DMP\_DONE* Digital Motion Processor (DMP) is done
- RAW\_DATA\_RDY* Raw data or FIFO data is ready

**12.12 Registers 27 to 40 – Sensor Registers**

**Type: Read only**

Register (Hex)	Register (Decimal)	Bit7	Bit6	Bit5	Bit4	Bit3	Bit2	Bit1	Bit0	Default Value*
1D	29	GYRO_XOUT_H								00h
1E	30	GYRO_XOUT_L								00h
1F	31	GYRO_YOUT_H								00h
20	32	GYRO_YOUT_L								00h
21	33	GYRO_ZOUT_H								00h
22	34	GYRO_ZOUT_L								00h
23	35	AUX_XOUT_H								00h
24	36	AUX_XOUT_L								00h
25	37	AUX_YOUT_H								00h
26	38	AUX_YOUT_L								00h
27	39	AUX_ZOUT_H								00h
28	40	AUX_ZOUT_L								00h

\*Default Value applies if sensor is disabled.

**Description:**

These registers contain the gyro, temperature, and auxillary (accel) sensor data for the MPU-3050. At any time, these values can be read from the device; however it is best to use the interrupt function to determine when new data is available.

Before being placed into these registers, the sensor data are first manipulated by the full scale setting (register 22) and the offset settings (registers 12 to 17).

**Parameters:**

- GYRO\_XOUT\_H/L* 16-bit X gyro output data (2's complement data format)
- GYRO\_YOUT\_H/L* 16-bit Y gyro output data (2's complement data format)

GYRO\_ZOUT\_H/L 16-bit Z gyro output data (2's complement data format)  
 AUX\_XOUT\_H/L 16-bit X aux (accel) output data (as available from aux)  
 AUX\_YOUT\_H/L 16-bit Y aux (accel) output data (as available from aux)  
 AUX\_ZOUT\_H/L 16-bit Z aux (accel) output data (as available from aux)

**12.13 Registers 58 to 59 – FIFO Count**

**Type: Read only**

Register (Hex)	Register (Decimal)	Bit7	Bit6	Bit5	Bit4	Bit3	Bit2	Bit1	Bit0	Default Value
3A	58	-	-	-	-	-	-	FIFO_COUNT_H		00h
3B	59	FIFO_COUNT_L								00h

**Description:**

These registers indicate how many bytes of valid data are contained in the FIFO. The FIFO can contain up to 512 bytes of data

If the FIFO gets filled up completely, the length will read 512. In this state, the MPU-3050 continues to put new sensor data into the FIFO, thus overwriting old FIFO data. Note, however, that the alignment of sensor data can change in this overflow condition. InvenSense recommends resetting the FIFO if an overflow condition occurs (use register 61), which will clear out the FIFO.

**Parameters:**

FIFO\_COUNT\_H/L Number of bytes currently in FIFO

**12.14 Register 60 – FIFO Data**

**Type: Read only**

Register (Hex)	Register (Decimal)	Bit7	Bit6	Bit5	Bit4	Bit3	Bit2	Bit1	Bit0	Default Value
3C	60	FIFO_DATA								00h

**Parameters:**

FIFO\_DATA Contains the FIFO data

**Description:**

This is the output register of the FIFO. Each read of this register gets the oldest contents of the MPU-3050 FIFO buffer; thus the data is read out in the same order that the DMP put the data in. If the FIFO operation is enabled, the DMP puts new data into the FIFO at each sample interval. The data that goes in is determined by the FIFO enable registers (18 and 19).

A burst read is required for reading *multiple* bytes from this register, since any read on this register causes an auto increment and a pre-fetch to occur.

Proper operation of the FIFO requires that at least one word (2 bytes) of data be left in the FIFO during any read operation. To implement this, it is recommended that one extra word be added to the end of the FIFO data so that all desired data can be read at each cycle, leaving the extra word remaining in the FIFO. This extra word will be read out (first) during the next read operation on the FIFO.

Data is read into the FIFO in the following order:

GYRO\_XOUT X Gyro  
 GYRO\_YOUT Y Gyro  
 GYRO\_ZOUT Z Gyro  
 AUX\_XOUT X Accelerometer high and low bytes (2 bytes)

**AUX\_YOUT**      Y Accelerometer high and low bytes (2 bytes)  
**AUX\_ZOUT**      Z Accelerometer high and low bytes (2 bytes)  
**FIFO\_FOOTER**    Last word for FIFO read (2 bytes)

For example, if it is desired to obtain gyro, and accel data from the FIFO, then one should also add one of the aux ADC readings (the required extra word) into the FIFO enable registers (18 or 19) in addition to the desired data. As shown in the figure below, the first time data is written to the FIFO, the FIFO will contain: *GYRO\_XOUT*, *GYRO\_YOUT*, *GYRO\_ZOUT*, *AUX\_XOUT*, *AUX\_YOUT*, *AUX\_ZOUT*, and *FIFO\_FOOTER*. The first FIFO read will read all but the *FIFO\_FOOTER* data, which will be read in the 2<sup>nd</sup> FIFO read. In the 2<sup>nd</sup> FIFO read, the *FIFO\_FOOTER* data that was left over from the previous read is read out first, followed by all but the last *FIFO\_FOOTER* data in the FIFO. This pattern of reading is continued, as shown in the figure below.

Note that the first FIFO read is similar to the subsequent reads in that one word of data is always left in the FIFO. It differs, though, in that in subsequent reads the leftover data from the previous read is read first; however, for the first read there is no leftover data from a previous read.

If the FIFO is allowed to overflow, it operates as a circular buffer in which at any time it contains the most recent 512 bytes. Recommended operation in this mode is to disable data going into the FIFO prior to reading the FIFO to avoid pointer conflicts. After halting the FIFO input, the 512 bytes in the FIFO should be read out in a single burst read. The first byte read will not be valid.

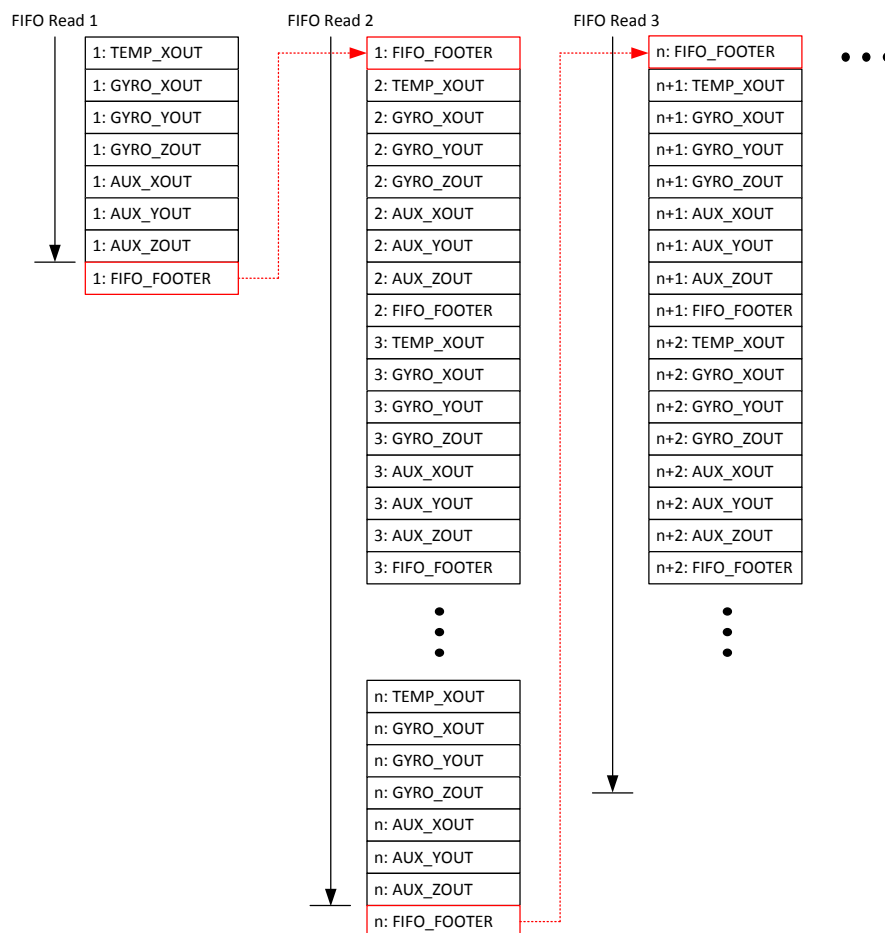

### Reading from the FIFO

**12.15 Register 61 – User Control**

**Type: Read/Write**

Register (Hex)	Register (Decimal)	Bit7	Bit6	Bit5	Bit4	Bit3	Bit2	Bit1	Bit0	Default Value
3D	61	-	FIFO_EN	AUX_IF_EN	-	AUX_IF_RST	-	FIFO_RST	GYRO_RST	00h

**Description:**

This register is used to enable various modes on the MPU-3050, as well as reset these functions.

For each of the functions that can be enabled, the function should be reset at the same time to assure it works properly. Note that the reset bits in the register are automatically cleared after the function is reset.

**Parameters:**

- FIFO\_EN* Enable FIFO operation for sensor data
- AUX\_IF\_EN* Enable third-party accelerometer interface via I2C (clear bit to pass through I2C bus)
- AUX\_IF\_RST* Reset third-party accelerometer interface function; set this only after changing *AUX\_IF\_EN* to 0.
- FIFO\_RST* Reset FIFO function; set this to clear FIFO or when changing *FIFO\_EN*
- GYRO\_RST* Reset gyro analog and digital functions

**12.16 Register 62 – Power Management**

**Type: Read/Write**

Register (Hex)	Register (Decimal)	Bit7	Bit6	Bit5	Bit4	Bit3	Bit2	Bit1	Bit0	Default Value
3E	62	H_RESET	SLEEP	STBY_XG	STBY_YG	STBY_ZG	CLK_SEL			00h

**Description:**

This register is used to manage the power control, select the clock source, and to issue a master reset to the device.

Setting the *SLEEP* bit in the register puts the device into a low power sleep mode. In this mode, only the serial interface and internal registers remain active, allowing for a very low standby current. Clearing this bit puts the device back into normal mode. The individual standby selections for each of the gyros should be used if any of them are not used by the application.

The power-up sequence of the *SLEEP* register bit is shown in the figure below. After VDD is applied to the part, *SLEEP* is initially low (part in normal operating mode). A short while afterwards, the internal charge pumps are brought up, and the part’s OTP memory is read, and *SLEEP* is set high, thus putting the part into its low-power sleep mode. The part stays in this mode until the register bit is cleared.

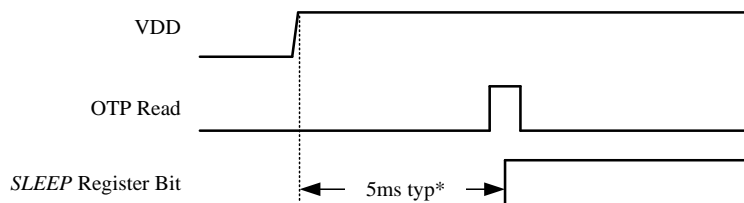

**Power-Up Sequence of *SLEEP* Register Bit**

The *CLK\_SEL* setting determines the device clock source as follows:

**CLK\_SEL**

CLK_SEL	Clock Source
0	Internal oscillator
1	PLL with X Gyro reference
2	PLL with Y Gyro reference
3	PLL with Z Gyro reference
4	PLL with external 32.768 kHz reference
5	PLL with external 19.2 MHz reference
6	Reserved
7	Stop clock and synchronous reset clock state

On power up, the MPU-3050 defaults to the internal oscillator. It is highly recommended that the device is configured to use one of the gyros (or an external clock) as the clock reference, due to the improved stability.

**Parameters:**

- H\_RESET*           Reset device and internal registers to the power-up-default settings
- SLEEP*             Enable low power sleep mode
- STBY\_XG*          Put gyro X in standby mode (1=standby, 0=normal)
- STBY\_YG*          Put gyro Y in standby mode (1=standby, 0=normal)
- STBY\_ZG*          Put gyro Z in standby mode (1=standby, 0=normal)
- CLK\_SEL*          Select device clock source

### 13 Reference

Please refer to “InvenSense MEMS Handling Application Note (AN-IVS-0002A-00)” for the following information:

- Manufacturing Recommendations
  - Assembly Guidelines and Recommendations
  - PCB Design Guidelines and Recommendations
  - MEMS Handling Instructions
  - ESD Considerations
  - Reflow Specification
  - Storage Specifications
  - Package Marking Specification
  - Tape & Reel Specification
  - Reel & Pizza Box Label
  - Packaging
  - Representative Shipping Carton Label
- Compliance
  - Environmental Compliance
  - DRC Compliance
  - Compliance Declaration Disclaimer

**14 Revision History**

Revision Date	Revision	Description
6/25/09	1.0	Initial Release
9/28/09	2.0	Changes for revision level compliance of MPU-3050 to MPU-3000 specification: Sec. 1.2 Added Revision B1 silicon note Sec. 1.3 Updated noise specification to 0.03°/s/√Hz Sec. 2.3 Added secondary I <sup>2</sup> C interface Sec. 3.1 Updated sensor specifications table Sec. 3.2 Changed VDD to 2.5 V and T <sub>A</sub> = 25°C Sec. 3.2-3.3 Changed electrical specifications table format and typical values Sec. 4.1 Updated pin-out and signal descriptions with new diagram Sec. 4.2 Updated typical operating circuit diagram Sec. 5.1 Updated new block diagram descriptions for primary and secondary I <sup>2</sup> C serial interfaces Sec. 5.9 Changed FIFO description Sec. 6 Edited digital interface Sec. 10.2 Updated package drawing/dimensions Sec. 10.7 Edited trace routing Sec. 13 Added Appendix 1.0 Errata for Revision G devices
11/5/09	2.1	Sec. 10 Added Material Handling Specification content to this section
12/23/09	2.2	Sec. 3.2 Updated Electrical Specifications with Power-supply ramp rate for VLOGIC Reference Voltage Sec. 3.3 Updated Level Output Current specifications for the Primary and Secondary I <sup>2</sup> C interfaces Sec. 3.4 Updated Frequency Variation Over Temperature specification for internal clock source Sec. 3.5.1 Updated ESD specification Sec. 4.4 Added recommended power-on procedure diagram
3/15/10	2.3	Sec 1.4 Added new InvenSense trademarks under Applications Sec 2.2 Edited Digital Output for 400 kHz standard (not up to) Sec 3.1 Changed Sensitivity Scale Factor to 115 LSB/(°/s) Sec 4.4 Updated Recommended Power-on Procedure diagram Sec 8.2 Modified Example Power Configuration diagram to remove IME-3000 reference Sec 11.2 Updated ESD-HBM for Device Component Level Tests Removed all references to IME-3000 and replaced with third-party accelerometer.
8/18/10	2.4	Section 3.1 Updated sensitivity scale factor, ZRO, Noise performance Section 3.2 Added operating current for without DMP case, added start-up time Updated table in section 8.2 with reference to ACCEL_VDDIO Added section 9.1 Demo Software Added sections 10 (Register Maps) and 11 (Register Description) Updated text and table in section 12.9 Added section 12.11 Storage Specifications

		Created a new section 14 for Environment Compliance Made this document specific to MPU-3050
10/15/14	2.5	Corrected typo for ZRO Variation Over Temperature from $\pm 0.03$ dps/C to $\pm 0.3$ dps/C
2/27/15	2.6	Updated ZRO Variation Over Temperature from $\pm 0.3$ dps/C to $\pm 0.15$ dps/C Removed references to the Temperature Sensor
3/10/16	2.7	Updated to Production; updated corporate logo and document format; updated trademarks, updated Applications, replaced sections 12.6 - 12.10, 12.12 – 12.14, and 13 with a new section 13; updated 1 <sup>st</sup> sentence of section 12; moved Assembly section before Register Map section; moved Revision History section to the end of the document

This information furnished by InvenSense is believed to be accurate and reliable. However, no responsibility is assumed by InvenSense for its use, or for any infringements of patents or other rights of third parties that may result from its use. Specifications are subject to change without notice. InvenSense reserves the right to make changes to this product, including its circuits and software, in order to improve its design and/or performance, without prior notice. InvenSense makes no warranties, neither expressed nor implied, regarding the information and specifications contained in this document. InvenSense assumes no responsibility for any claims or damages arising from information contained in this document, or from the use of products and services detailed therein. This includes, but is not limited to, claims or damages based on the infringement of patents, copyrights, mask work and/or other intellectual property rights.

Certain intellectual property owned by InvenSense and described in this document is patent protected. No license is granted by implication or otherwise under any patent or patent rights of InvenSense. This publication supersedes and replaces all information previously supplied. Trademarks that are registered trademarks are the property of their respective companies. InvenSense sensors should not be used or sold in the development, storage, production or utilization of any conventional or mass-destructive weapons or for any other weapons or life threatening applications, as well as in any other life critical applications such as medical equipment, transportation, aerospace and nuclear instruments, undersea equipment, power plant equipment, disaster prevention and crime prevention equipment.

©2016 InvenSense, Inc. All rights reserved. InvenSense, MotionTracking, MotionProcessing, MotionProcessor, MotionFusion, MotionApps, Digital Motion Processor, AAR, and the InvenSense logo are trademarks of InvenSense, Inc. Other company and product names may be trademarks of the respective companies with which they are associated.



©2016 InvenSense, Inc. All rights reserved.

## Looking for pricing, stock, or lifecycle information?

Click below to explore more details on WIN SOURCE:

 [View EV\\_MPU-3050](#) on WIN SOURCE

 [TDK InvenSense](#) Information

## Optimize Your Supply Chain with WIN SOURCE Solutions

-  Global Sourcing Solution
-  Obsolete Management
-  Cost Control Management
-  Shortage Management
-  Alternative Solution
-  Excess Inventory Management