



**THE DATASHEET OF
MPC8309CVMAHFCA**



MPC8309 PowerQUICC II Pro Processor

Overview

The MPC8309 processor is part of the entry level MPC830x communications portfolio based on the e300 core architecture. It addresses the requirements of networking applications, including I/O cards for low-end base stations, low-end Ethernet switches, residential gateways, modem/routers, industrial control, factory automation and test and measurement applications. The MPC830x portfolio extends current PowerQUICC processor offerings, delivering an impressive 1.99 DMIPS/MHz in CPU performance, additional functionality and faster interfaces while maintaining code compatibility with PowerQUICC I and PowerQUICC II processors. MPC830x processors also provide sub-\$10, low power consumption, a compact board footprint and a time to market advantage through cost-effective evaluation kits with optimized BSP and drivers.

Core Complex

The MPC8309 incorporates the e300c3 (MPC603e-based) core, built on Power Architecture® technology, which includes 16 KB of L1 instruction and data caches, dual integer units and on-chip memory management units (MMUs).

QUICC Engine Technology

A communications complex based on QUICC Engine technology forms the heart of the networking capability of the MPC830x portfolio. The QUICC Engine block contains several peripheral controllers and a 32-bit RISC controller. Protocol support is provided by the main workhorses of the device—the unified communication controllers (UCCs). Each of the five UCCs can support a variety of communication protocols, including 10/100 Mbps Ethernet and high-level data link control (HDLC). Two of the UCCs can also support IEEE® 1588 version-2 time stamping.

System Interface Unit

The MPC8309 processor also includes a 16/32-bit double data rate (DDR2) memory controller

MPC8309 Block Diagram

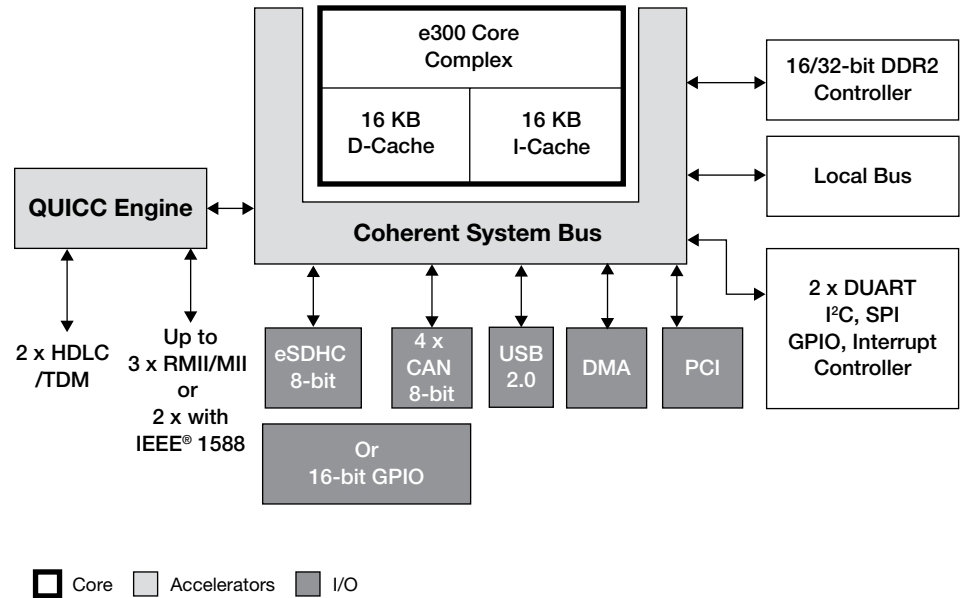

with ECC support, 4 x CAN, 4 x UARTs, High-Speed USB 2.0 controller, enhanced SDHC controller, a 32-bit peripheral component interconnect (PCI) controller, a 16-bit local bus and two direct memory access controllers (DMAC).

In summary, the MPC8309 provides users with a highly integrated, fully programmable communications processor helping to ensure that a cost-effective system solution can be quickly developed while offering the flexibility to accommodate new standards and evolving system requirements.



MPC8309 Features

- Excellent performance, low-power, sub-\$10 communications processor
- The e300 core, built on Power Architecture technology, with dual integer units enables more efficient operations to be conducted in parallel, resulting in a significant performance improvement
- The single-RISC QUICC Engine communications module offers a future-proof solution for next-generation designs by supporting programmable protocol termination and network interface termination to meet evolving protocol standards
- DDR2 memory controller—one 16/32-bit interface at up to 333 MHz with ECC support
- Peripheral interfaces such as 32-bit, 66 MHz PCI, 16-bit, 66 MHz local bus interface and High-Speed USB 2.0, 4 x CAN, 4 x UARTs, enhanced SDHC controller

- High degree of software compatibility with previous generation PowerQUICC processor-based designs for backward compatibility and easier software migration

QUICC Engine Technology

- Single 32-bit RISC controller for flexible support of communications peripherals
- Serial DMA channel for receive and transmit on all serial channels
- Five UCCs supporting the following interfaces (not all simultaneously)
 - 10/100 Mbps Ethernet/IEEE Std. 802.3 through MII and RMII interfaces
 - IEEE 1588 version-2 support
 - HDLC/transparent (bit rate up to QUICC Engine operating frequency divided by eight)
 - HDLC bus (bit rate up to 10 Mbps)

- PROFIBUS protocol support
- Asynchronous HDLC (bit rate up to 2 Mbps)
- Two TDM interfaces supporting up to 128 channels, each running at 64 Kbps

The UCCs are similar to the PowerQUICC II peripherals in that the serial communications controller (SCC) supports the UART and HDLC bus and fast serial communications controller (FCC) supports fast Ethernet and HDLC.

Enablement

The MPC8309-KIT is a cost-optimized reference development kit for the MPC8309 processor. The kit consists of a carrier card and processor-specific system on module (SOM) card. The SOM interfaces with peripherals through the carrier card.

This same carrier card can be used for the MPC8306 processor SOM card. The MPC830x-KIT board support package (BSP) can be customized per project and combined with off-the-shelf software for product development. The BSP components provide the tools, device drivers and additional features needed for embedded Linux® OS projects.

MPC8309-KIT Contents

- MPC8309 SOM board
- MPC830x carrier card
- BSP
- UART cable
- Ethernet cable
- Power adaptor (12V-5A) and cable

MPC830x PowerQUICC II Pro Processor Portfolio				
	MPC8308	MPC8309	MPC8306	MPC8306S
Core	e300	e300	e300	e300
I-Cache/D-Cache	16K/16K	16K/16K	16K/16K	16K/16K
Floating Point Unit	Yes	Yes	Yes	Yes
Core Frequency	266/333/400	266/333/400/417	133/200/266	133/200/266
QUICC Engine Subsystem	No	32-bit RISC	32-bit RISC	32-bit RISC
Memory Controller	16/32-bit DDR2 with ECC	16/32-bit DDR2 with ECC	16-bit DDR2	16-bit DDR2
Local Bus	8/16-bit up to 66 MHz	8/16-bit up to 66 MHz	8/16-bit up to 66 MHz	8/16-bit up to 66 MHz
PCI Interface	No (1 x PCI Express)	32-bit up to 66 MHz	No	No
Ethernet	2 x 10/100/1000 MII/RGMII	3 x 10/100 MII/RMII or 2 x 10/100 with IEEE 1588 V2	3 x 10/100 MII / RMII or 2 x 10/100 with IEEE 1588 V2	3 x 10/100 MII/RMII
USB 2.0	Yes	Yes	Yes	Yes
UART	Yes (2 x)	Yes (4 x)	Yes (4 x)	Yes (4 x)
I²C Controller	Dual	Dual	Dual	Dual
SPI	Yes	Yes	Yes	Yes
Interrupt Controller	IPIC	IPIC	IPIC	IPIC
IEEE® 1588 Support	Yes	Yes	Yes	No
eSDHC	Yes	Yes	Yes	No
FlexCAN	No	Yes	Yes	No
Package	473-pin MAPBGA	489-pin MAPBGA	369-pin MAPBGA	369-pin MAPBGA

Learn More:

For current information about Freescale products and documentation, please visit freescale.com/PowerQUICC.



Freescale, the Freescale logo and PowerQUICC are trademarks of Freescale Semiconductor, Inc. Reg. U.S. Pat. & Tm.Off. QUICC Engine is a trademark of Freescale Semiconductor, Inc. All other product or service names are the property of their respective owners. The Power Architecture and Power.org word marks and the Power and Power.org logos and related marks are trademarks and service marks licensed by Power.org.
© 2010-2011 Freescale Semiconductor, Inc.

Document Number: MPC8309FS
REV 2



Looking for pricing, stock, or lifecycle information?

Click below to explore more details on WIN SOURCE:

⊖ [View MPC8309CVMAHFCA on WIN SOURCE](#)

⊖ [NXP / Nexperia Information](#)

Optimize Your Supply Chain with WIN SOURCE Solutions

- ✓ Global Sourcing Solution
- ✓ Obsolete Management
- ✓ Cost Control Management
- ✓ Shortage Management
- ✓ Alternative Solution
- ✓ Excess Inventory Management