



**THE DATASHEET OF
MP3310EQ-LF-P**



DESCRIPTION

The MP3310 is a monolithic step-up converter designed for driving arrays of WLEDs from a wide input supply range. The MP3310 uses current mode, fixed frequency architecture to regulate the LED current to user programmed value set by an external current setting resistor. The switching frequency is also programmable with an external resistor.

The MP3310 features true PWM dimming, which allows the flexible control of the backlighting luminance under wide range of the ambient brightness.

The MP3310 is turned off if an over-voltage condition is present due to an open circuit condition. Use one external resistor voltage divider to program OVP threshold. The MP3310 also includes under-voltage lockout, current limiting and thermal overload protection preventing damage in the event of an output overload.

The MP3310 is available in small 10-pin QFN 3x3mm package.

FEATURES

- Internal 0.3Ω Power MOSFET
- Wide 4.5V to 25V Operating Input Range
- Drives up to 12 Series White LEDs
- Up to 93% Efficiency
- True PWM Dimming
- Adjustable Switching Frequency
- Adjustable Open Load Shutdown Voltage
- Internal 1.3A Current Limit
- UVLO, Thermal Shutdown
- Available in 3mm x 3mm QFN10 Package

APPLICATIONS

- LCD Panels
- Digital Picture Frames
- Handheld Computers and PDAs
- Digital Still Cameras
- Small LCD Displays

For MPS green status, please visit MPS website under Quality Assurance. "MPS" and "The Future of Analog IC Technology" are Registered Trademarks of Monolithic Power Systems, Inc.

TYPICAL APPLICATION

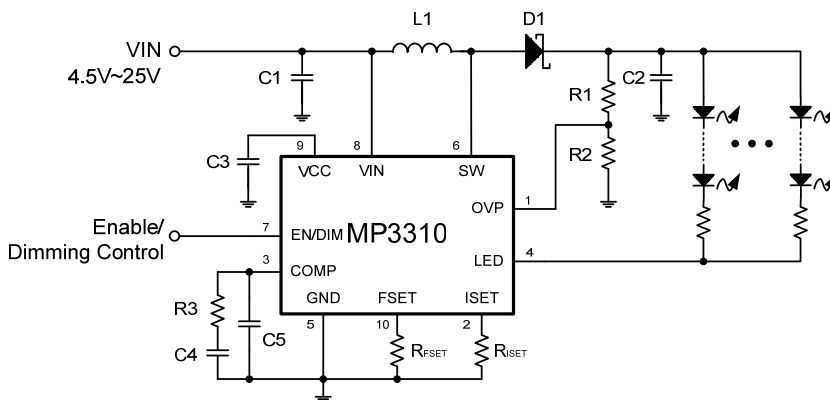

VIN vs. Efficiency

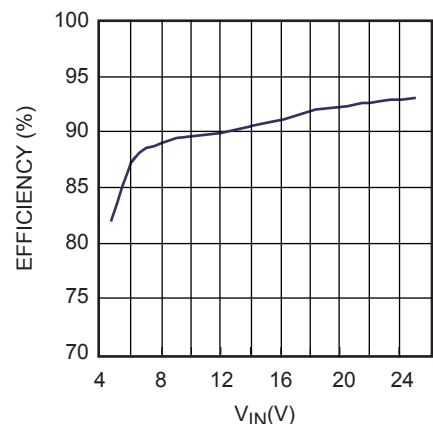

ORDERING INFORMATION

Part Number*	Package	Top Marking	Free Air Temperature (T _A)
MP3310EQ	QFN10 (3mm x 3mm)	5R	-20°C to +85°C

* For Tape & Reel, add suffix -Z (e.g. MP3310EQ-Z);
 For RoHS Compliant Packaging, add suffix -LF (e.g. MP3310EQ-LF-Z)

PACKAGE REFERENCE

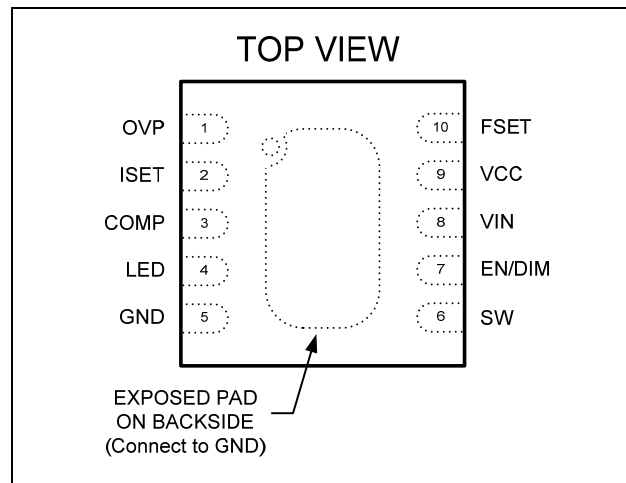

ABSOLUTE MAXIMUM RATINGS ⁽¹⁾

V _{IN}	-0.3V to +30V
V _{SW} , V _{LED}	-0.3V to +50V
All Other Pins	-0.3V to +6.3V
Continuous Power Dissipation (T _A = +25°C) ⁽²⁾	2.5W
Junction Temperature	150°C
Lead Temperature	260°C
Storage Temperature	-65°C to +150°C

Recommended Operating Conditions ⁽³⁾

Supply Voltage V _{IN}	4.5V to 25V
Operating Junc Temp T _J	-20°C to +125°C

Thermal Resistance ⁽⁴⁾	θ_{JA}	θ_{JC}
QFN10 (3mm x 3mm)	50	12 ... °C/W

Notes:

- Exceeding these ratings may damage the device.
- The maximum allowable power dissipation is a function of the maximum junction temperature T_J(MAX), the junction-to-ambient thermal resistance θ_{JA} , and the ambient temperature T_A. The maximum allowable continuous power dissipation at any ambient temperature is calculated by P_D(MAX)=(T_J(MAX)-T_A)/ θ_{JA} . Exceeding the maximum allowable power dissipation will cause excessive die temperature, and the regulator will go into thermal shutdown. Internal thermal shutdown circuitry protects the device from permanent damage.
- The device is not guaranteed to function outside of its operation conditions.
- Measured on JESD51-7 4-layer board.

ELECTRICAL CHARACTERISTICS

$V_{IN} = 12V$, $V_{EN} = 5V$, $T_A = +25^\circ C$, unless otherwise noted.

Parameters	Symbol	Condition	Min	Typ	Max	Units
Operating Input Voltage	V_{IN}		4.5		25	V
Supply Current (Shutdown)	I_{IN_SD}	$V_{EN} = 0V$			1	μA
Supply Current (Quiescent)	I_{IN_QS}	$V_{EN} = 5V$, $V_{LED} = 1V$		1	2	mA
LDO Output Voltage	V_{CC}	$V_{EN} = 5V$, $6V < V_{IN} < 25V$, $0 < I_{VCC} < 10mA$	4.3	5.0	5.5	V
Switching Frequency	f_{SW}	$R_{FSET} = 50k\Omega$	470	560	650	kHz
		R_{FSET} Open	0.8	1	1.2	MHz
Maximum Duty Cycle	D_{MAX}		90			%
Under Voltage Lockout						
IN Under Voltage Lockout	V_{CC_UVLO}	V_{IN} Rising	3.6	3.9	4.2	V
Under Voltage Lockout Hysteresis				450		mV
Open Load Shutdown Threshold	V_{OVP}	V_{OV} Rising	1.18	1.24	1.30	V
Enable & Dimming						
EN Low Threshold	V_{EN_LOW}	V_{EN} Falling	0.6			V
EN High Threshold	V_{EN_HIGH}	V_{EN} Rising			1.6	V
EN Disable Timer			10			ms
Current Regulation Delay		From V_{EN} Rising Edge		2		μs
LED Current Regulation						
LED Current	I_{LED}	$R_{ISET} = 60k\Omega$	74.1	76.8	79.5	mA
LED Regulation Voltage	V_{LED}	$I_{LED} = 80mA$		500		mV
Output Switch						
SW On-Resistance	R_{ON}			0.3		Ω
SW Current Limit		Duty Cycle = 90%		1.3		A
Thermal Shutdown				150		$^\circ C$
LED Switch (M2, refer block diagram) On Resistance				2		Ω

PIN FUNCTIONS

Pin #	Name	Pin Function
1	OVP	Open Load Protection Programming Pin. Connect a resistor divider from output to this pin to program the OVP threshold. When this pin voltage reaches the shutdown threshold 1.24V, the switch will be turned off and latch up until the IC is turned off and enabled again.
2	ISET	LED Current Set. Tie a current setting resistor from this pin to ground to program the whole LED current.
3	COMP	Step-up Converter Compensation Pin. This pin is used to compensate the regulation control loop. Connect a capacitor or a series RC network from COMP to GND.
4	LED	LED Current Input. This pin is the open-drain output of an internal dimming control switch. Connect the LED cathode to this pin. With internal 500mV reference, the current flows into LED pin should be less than 120mA for normal operation.
5	GND, Exposed Pad	Ground. Connect exposed pad to GND plane for proper thermal performance.
6	SW	Power Switch Output. SW is the drain of the internal MOSFET switch. Connect the power inductor and output rectifier to SW.
7	EN/DIM	ON/OFF Control and Dimming Command Input. To use PWM dimming, add a 200Hz to 2kHz square wave signal to this pin.
8	VIN	Input Supply Pin. Must be locally bypassed.
9	VCC	The Internal 5V Linear Regulator Output. VCC provides power supply for the internal MOSFET switch gate driver and the internal control circuitry. Bypass VCC to GND with a ceramic capacitor. If VIN is less than 5.5V, apply an external 5V supply directly on VCC.
10	FSET	Switching Frequency Programming Pin. Connect a resistor to ground to set the switching frequency.

TYPICAL PERFORMANCE CHARACTERISTICS

$V_{IN} = 12V$, $V_{EN} = 5V$, $I_{LED} = 80mA$, 10WLEDs 4Strings, unless otherwise noted.

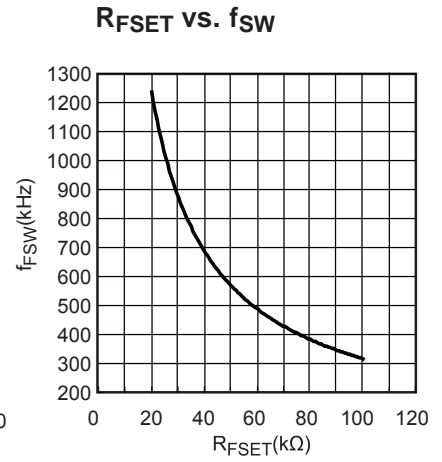
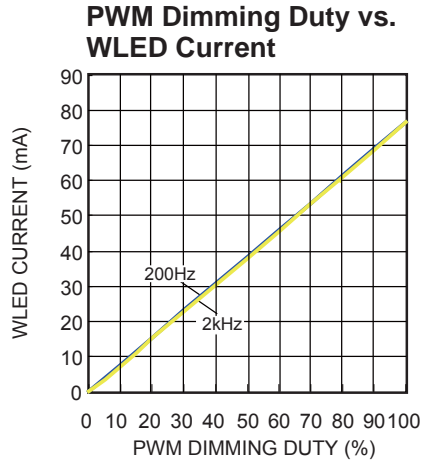
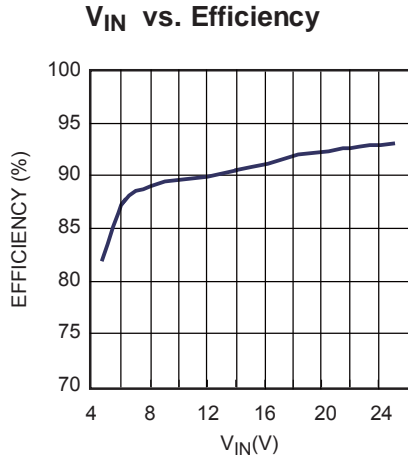

Steady State

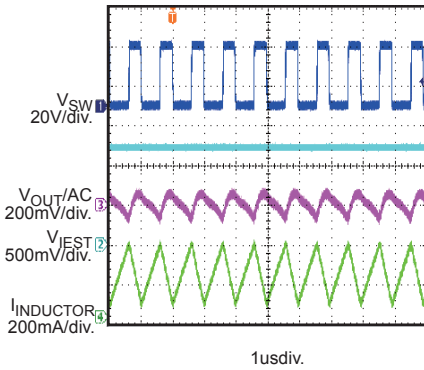

Enable Startup

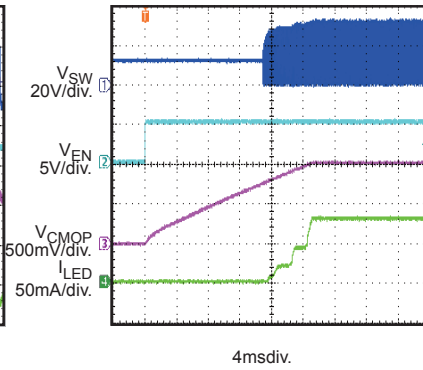

Enable Shutdown

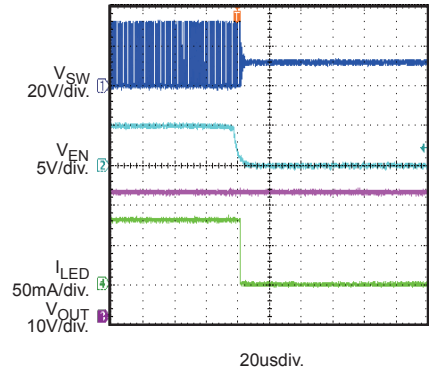

PWM Dimming

$f_{PWM} = 200Hz$, DPWM=50%

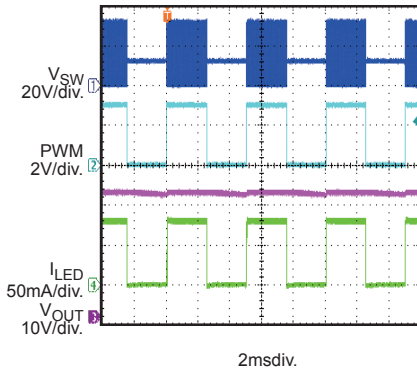

PWM Dimming

$f_{PWM} = 2kHz$, DPWM=50%

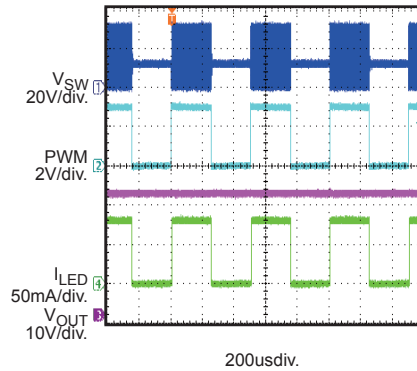

Open Load Protection

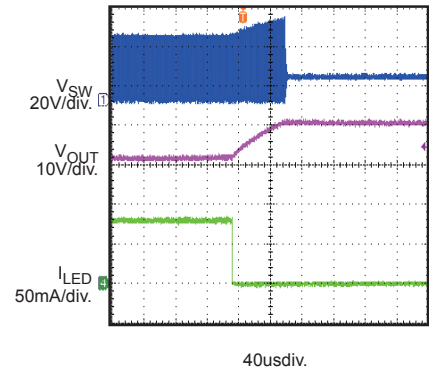

FUNCTION DIAGRAM

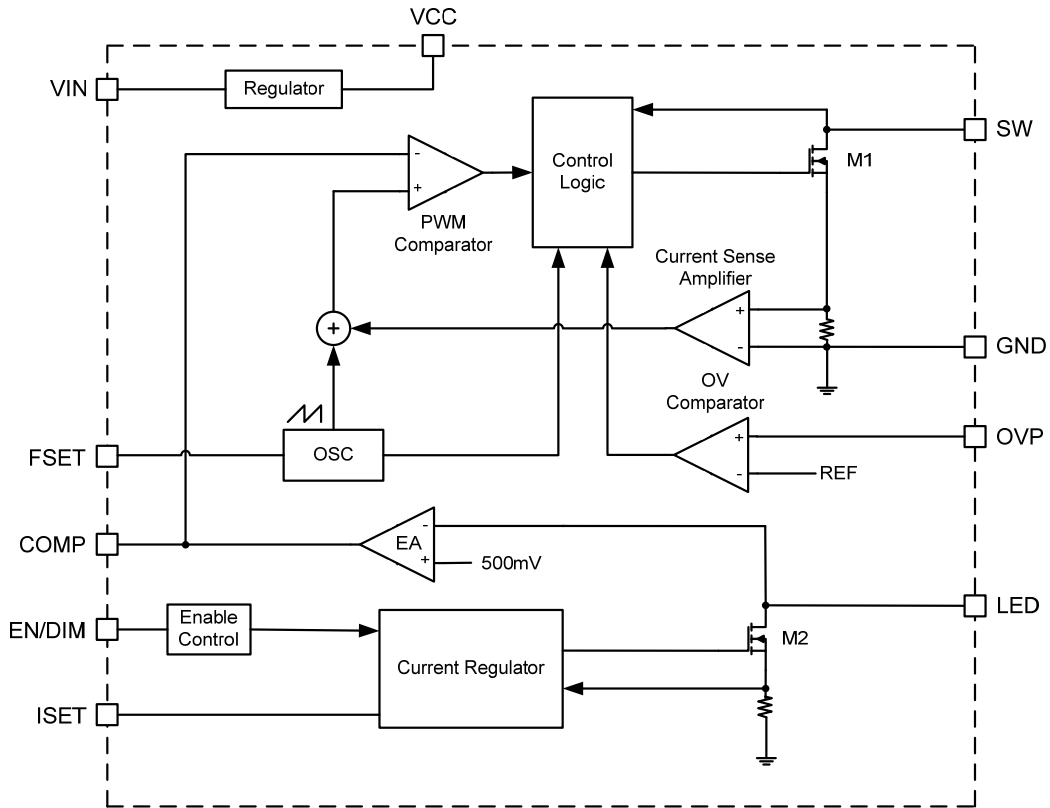

Figure 1—MP3310 Function Block Diagram

OPERATION

The MP3310 employs a constant frequency, peak current mode step-up converter and internal regulated current source to regulate the array of white LEDs. The operation of the MP3310 can be understood by referring to the block diagram of Figure 1.

Internal 5V Regulator

The MP3310 includes an internal linear regulator (VCC). When VIN is greater than 5.5V, this regulator offers a 5V power supply for the internal MOSFET switch gate driver and the internal control circuitry. The VCC voltage drops to 0V when the chip shuts down. In the application of VIN smaller than 5.5V, tie VCC and VIN together. The MP3310 features Under Voltage Lockout. The chip is disabled until VCC exceeds the UVLO threshold. And the hysteresis of UVLO is approximately 450mV.

System Startup

When the MP3310 is enabled and VCC exceeds the UVLO threshold, the capacitor on COMP pin is charged. Once the COMP level reaches to about 750mV, the switching begins and the MP3310 starts boosting the step-up converter.

Step-up Converter

The converter operation frequency is adjustable by FSET setting resistor, which is helpful for optimizing the external components sizes and improving the efficiency.

At the beginning of each cycle, the power FET is turned on with the internal clock. To prevent sub-harmonic oscillations at duty cycles greater than 50 percent, a stabilizing ramp is added to the output of the current sense amplifier and the result is fed into the PWM comparator. When this result voltage reaches the output voltage of the

error amplifier (V_{COMP}) the power FET is turned off.

The COMP voltage at the output of the internal error amplifier is an amplified signal of the difference between the 500mV reference voltage and the feedback voltage. The converter automatically provides enough bus voltage to power the LED array.

If the feedback voltage drops below the 500mV reference, the output of the error amplifier increases. It results in more current flowing through the power FET, thus increasing the power delivered to the output. In this way it forms a close loop to make the LED current in regulation.

At light-load or VOUT near to VIN operation, the converter runs into the pulse-skipping mode, the FET is turned on for a minimum on-time, and then the converter discharges the power to the output in the remnant period. The FET will keep off until the output voltage needs to be boosted again.

Dimming Control

The MP3310 incorporates both Enable and PWM dimming onto a single control pin. The part features true PWM dimming which results in PWM chopping of the current in the LEDs to provide flexible LED brightness control.

Open Load Protection

The open load protection is achieved through the over voltage protection. If LED array is open, the LED pin is pulled to ground and the IC keeps charging the output voltage until it reach OVP threshold. Then the MP3310 shuts down the step-up converter.

APPLICATION INFORMATION

Setting the Switching Frequency

The resistor on FSET pin is used to set the switching frequency. The relationship of the operating frequency vs. the FSET resistor is shown as the curve in page 5. A 20kΩ to 100kΩ FSET resistor, which sets the operating frequency from around 1.2MHz to 300kHz, is recommended. Leaving the FSET pin open sets the switching frequency to 1MHz as default.

Setting the LED Current

The regulated total LED current is identical and set through the current setting resistor on the ISET pin through the use of the equation:

$$I_{LED} = 4605V / R_{ISET}$$

For $R_{ISET}=60.4k\Omega$, the LED current is set to about 76.2mA. The ISET pin can not be open.

With internal 500mV reference, the current flows into LED pin should be less than 120mA for normal operation.

PWM Dimming

Apply a 200Hz to 2kHz square waveform to the EN pin to implement PWM dimming of the LEDs. The minimum recommended amplitude of the PWM signal is 2V.

Setting the Over Voltage Protection

The open load protection is achieved through the over voltage protection (OVP) setting. In some cases, LED strings failure results in the feedback voltage is always zero. The part then keeps boosting the output voltage higher and higher. If the output voltage reaches the programmable OVP threshold, the protection will be triggered.

To make sure the chip functions properly in normal operation, the OVP setting resistor divider must be set with a proper value. The recommended OVP point is about 1.3 times higher than the output voltage for normal operation.

$$V_{OV}=1.24V \times (R1+R2)/R2$$

Selecting the Inductor

A 10μH to 22μH inductor with a DC current rating of at least 40% higher than the maximum input current is recommended for most applications at wide input range. For highest efficiency, the inductor's DC resistance should be as small as possible.

Selecting the Input Capacitor

The input capacitor reduces the surge current drawn from the input supply and the switching noise from the device. The input capacitor impedance at the switching frequency should be less than the input source impedance to prevent high frequency switching current from passing through the input. Ceramic capacitors with X5R or X7R dielectrics are highly recommended because of their low ESR and small temperature coefficients. For most applications, two 4.7μF capacitors paralleled is sufficient.

Selecting the Output Capacitor

The output capacitor keeps the output voltage ripple small and ensures feedback loop stability. The output capacitor impedance should be low at the switching frequency. Ceramic capacitors with X7R dielectrics are recommended for their low ESR characteristics. For most applications, a 1μF ceramic capacitor is sufficient.

Layout Considerations

Careful attention must be paid to the PCB board layout and components placement. Proper layout of the high frequency switching path is critical to prevent noise and electromagnetic interference problems. The loop of MP3310 SW to GND pin, output diode, and output capacitor is flowing with high frequency pulse current. It must be as short as possible. The IC exposed pad is internally connected to GND pin. Lay the GND plane widely for proper thermal performance. The VCC pin is the power supply input for the internal MOSFET switch gate driver and the internal control circuitry. It must be locally bypassed.

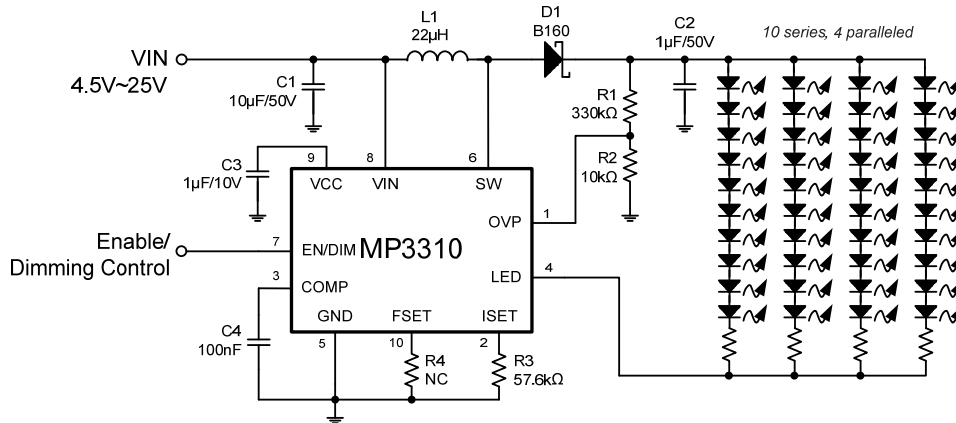
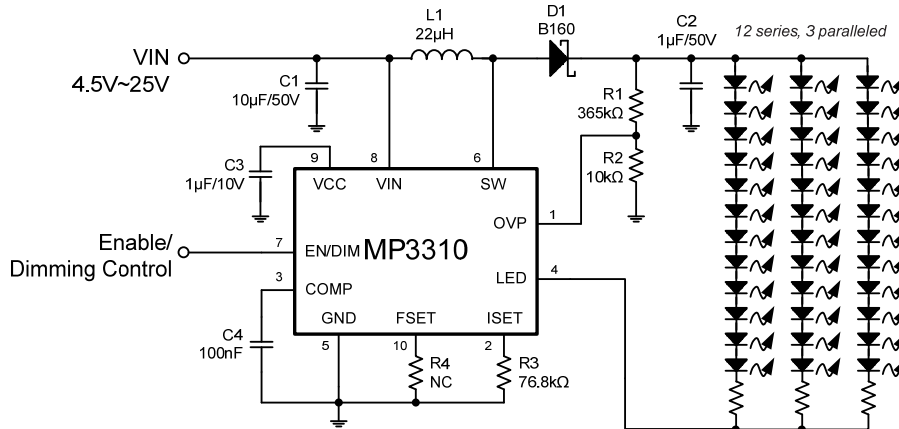
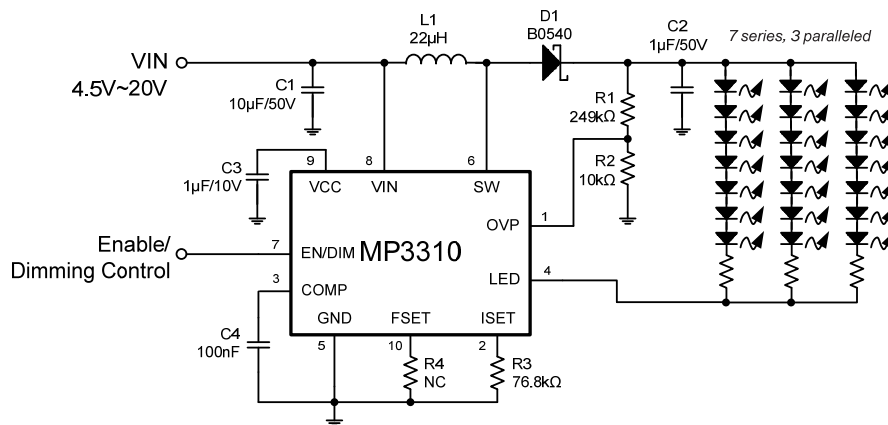
TYPICAL APPLICATION CIRCUIT

Figure 2—Step-up White LED Driver Application for Driving 4 Strings of 10 WLEDs

Figure 3—Step-up White LED Driver Application for Driving 3 Strings of 12 WLEDs

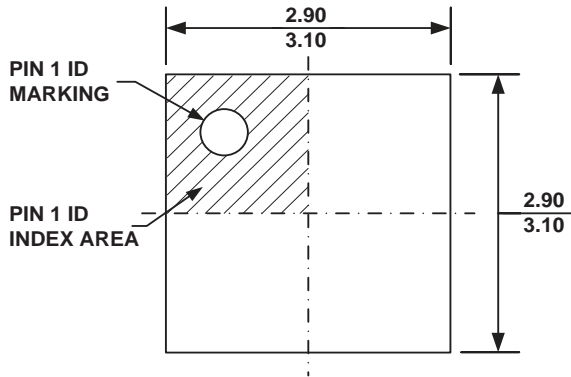
Figure 4—Step-up White LED Driver Application for Driving 3 Strings of 7 WLEDs

PACKAGE INFORMATION

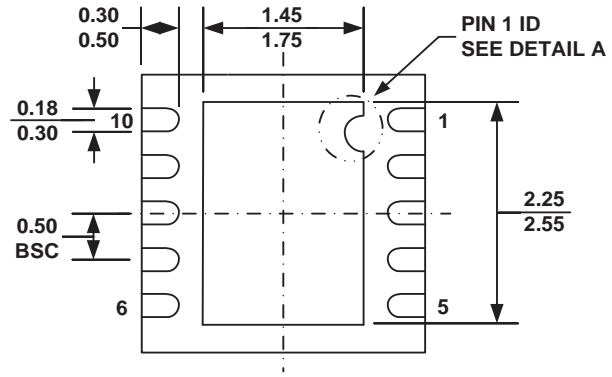
QFN10 (3mm x 3mm)



TOP VIEW



BOTTOM VIEW

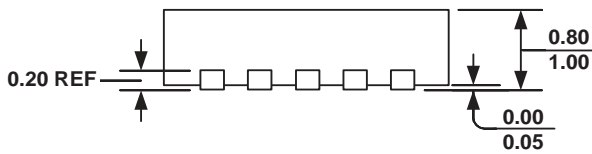

SIDE VIEW

PIN 1 ID OPTION A
R0.20 TYP.



PIN 1 ID OPTION B
R0.20 TYP.

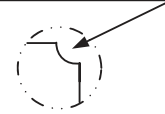

DETAIL A

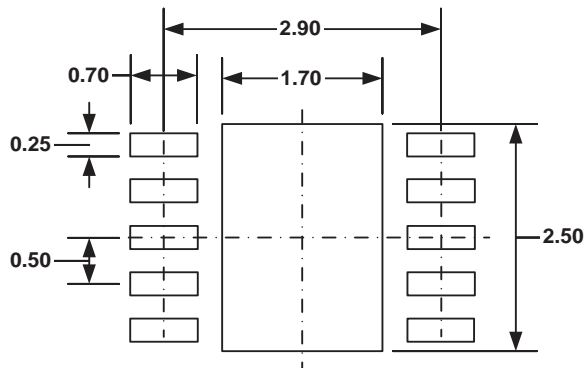

RECOMMENDED LAND PATTERN



NOTE:

- 1) ALL DIMENSIONS ARE IN MILLIMETERS.
- 2) EXPOSED PADDLE SIZE DOES NOT INCLUDE MOLD FLASH.
- 3) LEAD COPLANARITY SHALL BE 0.10 MILLIMETER MAX.
- 4) DRAWING CONFORMS TO JEDEC MO-229, VARIATION VEED-5.
- 5) DRAWING IS NOT TO SCALE.

NOTICE: The information in this document is subject to change without notice. Users should warrant and guarantee that third party Intellectual Property rights are not infringed upon when integrating MPS products into any application. MPS will not assume any legal responsibility for any said applications.

Looking for pricing, stock, or lifecycle information?

Click below to explore more details on WIN SOURCE:

-  [View MP3310EQ-LF-P on WIN SOURCE](#)
-  [Monolithic Power Systems Inc. Information](#)

Optimize Your Supply Chain with WIN SOURCE Solutions

-  Global Sourcing Solution
-  Obsolete Management
-  Cost Control Management
-  Shortage Management
-  Alternative Solution
-  Excess Inventory Management