

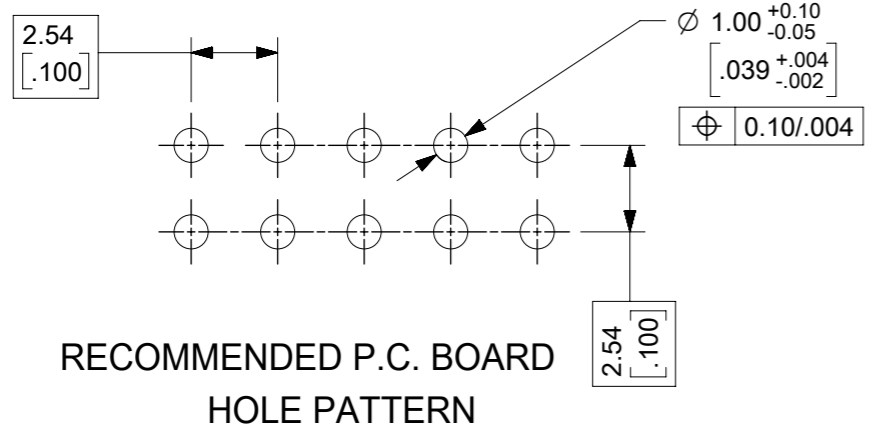

THE DATASHEET OF
901301212

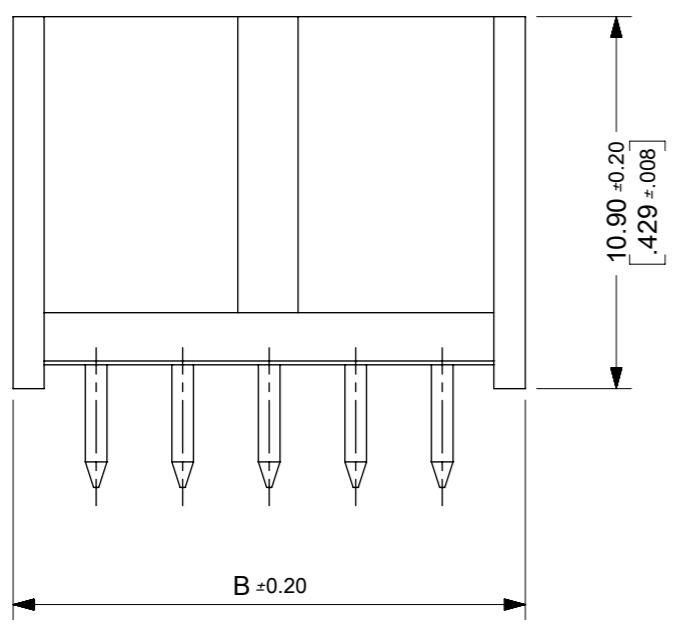

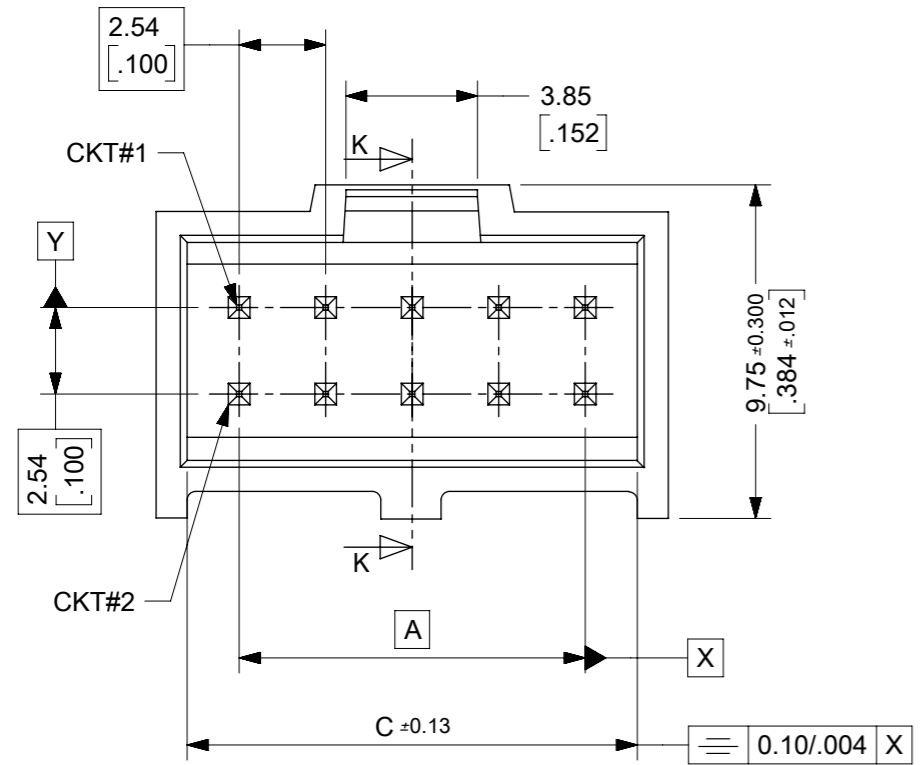

- NOTES :
- MATERIAL:-
 - PIN:- (0.65)/.0255 SQ. BRASS WIRE.
 - HOUSING:- 15% GLASS FILLED POLYESTER
 - UL 94 V-0 COLOUR BLACK
 - FOR PLATING VERSIONS AND VOID VERSIONS SEE SHEET 2.
 - MEASUREMENT POINT FOR MINIMUM PLATING THICKNESS.
 - FOR PRODUCT SPEC SEE PS-99020-0001
 - RECOMMENDED PCB THICKNESS: 1.60mm

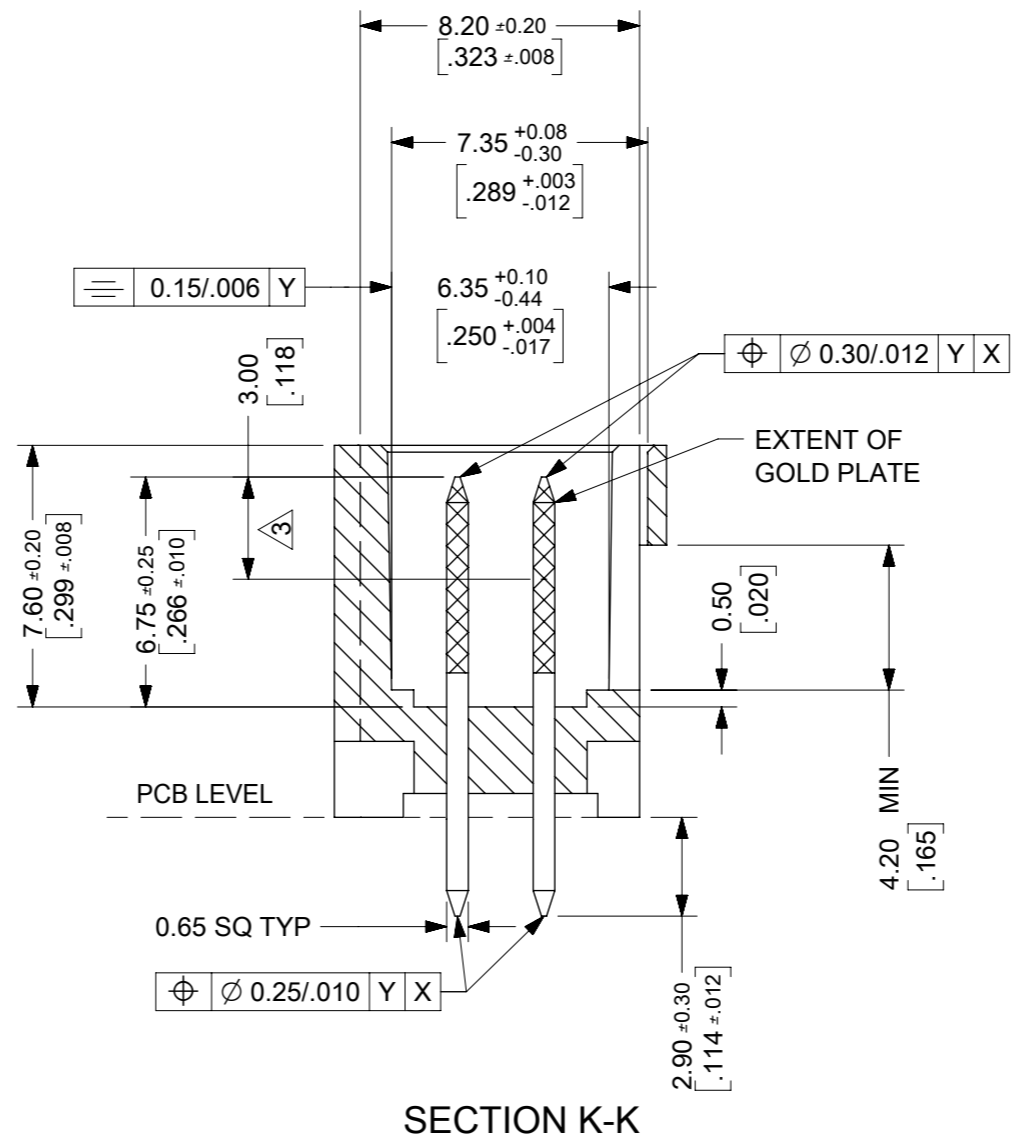

CKT	DIM A	DIM B	DIM C
6	(5.08)/.200	(9.96)/.392	(8.12)/.320
8	(7.62)/.300	(12.50)/.492	(10.66)/.420
10	(10.16)/.400	(15.04)/.592	(13.20)/.520
12	(12.70)/.500	(17.58)/.692	(15.74)/.620
14	(15.24)/.600	(20.12)/.792	(18.28)/.720
16	(17.78)/.700	(22.66)/.892	(20.82)/.820
18	(20.32)/.800	(25.20)/.992	(23.36)/.920
20	(22.86)/.900	(27.74)/1.092	(25.90)/1.020
22	(25.40)/1.000	(30.28)/1.192	(28.44)/1.120
24	(27.94)/1.100	(32.82)/1.292	(30.98)/1.220
26	(30.48)/1.200	(35.36)/1.392	(33.52)/1.320
28	(33.02)/1.300	(37.90)/1.492	(36.06)/1.420
30	(35.56)/1.400	(40.44)/1.592	(38.60)/1.520
32	(38.10)/1.500	(42.98)/1.692	(41.15)/1.620
34	(40.64)/1.600	(45.52)/1.792	(43.68)/1.720
36	(43.18)/1.700	(48.06)/1.892	(46.22)/1.820
38	(45.72)/1.800	(50.60)/1.992	(48.76)/1.920
40	(48.26)/1.900	(53.14)/2.092	(51.30)/2.020
42	(50.80)/2.000	(55.68)/2.192	(53.84)/2.120
44	(53.34)/2.100	(58.22)/2.292	(56.38)/2.220
46	(55.88)/2.200	(60.76)/2.392	(58.92)/2.320
48	(58.42)/2.300	(63.30)/2.492	(61.46)/2.420
50	(60.96)/2.400	(65.84)/2.592	(64.00)/2.520
52	(63.50)/2.500	(68.38)/2.692	(66.54)/2.620
54	(66.04)/2.600	(70.92)/2.792	(69.08)/2.720
56	(68.58)/2.700	(73.46)/2.892	(71.62)/2.820
58	(71.12)/2.800	(76.00)/2.992	(74.16)/2.920
60	(73.66)/2.900	(78.54)/3.092	(76.70)/3.020
62	(76.20)/3.000	(81.08)/3.192	(79.24)/3.120
64	(78.74)/3.100	(83.62)/3.292	(81.78)/3.220
66	(81.28)/3.200	(86.16)/3.392	(84.32)/3.320
68	(83.82)/3.300	(88.70)/3.492	(86.86)/3.420

THIS DRAWING CONTAINS INFORMATION THAT IS PROPRIETARY TO MOLEX ELECTRONIC TECHNOLOGIES, LLC AND SHOULD NOT BE USED WITHOUT WRITTEN PERMISSION

DIMENSION UNITS MM/IN	SCALE NTS	CURRENT REV DESC:		molex		
GENERAL TOLERANCES (UNLESS SPECIFIED)		EC NO: 618066				
4 PLACES ±	±	DRWN: NMANE02	2019/05/28	DUAL ROW STRAIGHT SHROUDED HEADER		
3 PLACES ±	± 0.004	CHK'D: NMANE02	2019/05/28	PRODUCT CUSTOMER DRAWING		
2 PLACES ±	0.1 ±	APPR: MRAMAKRISHNA	2019/06/07	DOCUMENT NUMBER		
1 PLACE ±	±	INITIAL REVISION:		SDA-90130		
0 PLACES ±	±	DRWN: KS	1988/08/23	DOC TYPE	DOC PART	REVISION
ANGULAR TOL ± 0.5°		APPR: MLONG	2010/02/19	PSD	001	CA4
DRAFT WHERE APPLICABLE MUST REMAIN WITHIN DIMENSIONS	THIRD ANGLE PROJECTION	DRAWING	SERIES	MATERIAL NUMBER	CUSTOMER	SHEET NUMBER
		A3-SIZE	90130	SEE TABLE	GENERAL MARKET	1 OF 4

VERSION FULLY LOADED

NO OF CKTS	HSG CKT SIZE	PART NUMBER			
		PLATING TYPE A	PLATING TYPE E	PLATING TYPE F	PLATING TYPE G
6	6	90130-X106	90130-X206	90130-X306	90130-X406
8	8	90130-X108	90130-X208	90130-X308	90130-X408
10	10	90130-X110	90130-X210	90130-X310	90130-X410
12	12	90130-X112	90130-X212	90130-X312	90130-X412
14	14	90130-X114	90130-X214	90130-X314	90130-X414
16	16	90130-X116	90130-X216	90130-X316	90130-X416
18	18	90130-X118	90130-X218	90130-X318	90130-X418
20	20	90130-X120	90130-X220	90130-X320	90130-X420
22	22	90130-X122	90130-X222	90130-X322	90130-X422
24	24	90130-X124	90130-X224	90130-X324	90130-X424
26	26	90130-X126	90130-X226	90130-X326	90130-X426
28	28	90130-X128	90130-X228	90130-X328	90130-X428
30	30	90130-X130	90130-X230	90130-X330	90130-X430
32	32	90130-X132	90130-X232	90130-X332	90130-X432
34	34	90130-X134	90130-X234	90130-X334	90130-X434
36	36	90130-X136	90130-X236	90130-X336	90130-X436
38	38	90130-X138	90130-X238	90130-X338	90130-X438
40	40	90130-X140	90130-X240	90130-X340	90130-X440
42	42	90130-X142	90130-X242	90130-X342	90130-X442
44	44	90130-X144	90130-X244	90130-X344	90130-X444
46	46	90130-X146	90130-X246	90130-X346	90130-X446
48	48	90130-X148	90130-X248	90130-X348	90130-X448
50	50	90130-X150	90130-X250	90130-X350	90130-X450
52	52	90130-X152	90130-X252	90130-X352	90130-X452
54	54	90130-X154	90130-X254	90130-X354	90130-X454
56	56	90130-X156	90130-X256	90130-X356	90130-X456
58	58	90130-X158	90130-X258	90130-X358	90130-X458
60	60	90130-X160	90130-X260	90130-X360	90130-X460
62	62	90130-X162	90130-X262	90130-X362	90130-X462
64	64	90130-X164	90130-X264	90130-X364	90130-X464
66	66	90130-X166	90130-X266	90130-X366	90130-X466
68	68	90130-X168	90130-X268	90130-X368	90130-X468

NOTES :

- FOR ASSEMBLY, SEE SHEET 1.
- REFER TO LEGEND FOR PLATING OPTIONS.

90130 - * * * *

PLATING TYPES

STYLE: - 1. STRAIGHT PIN VERSION
8. VERSION WITH VOIDS

- TYPE A:
3.0µm MIN. TIN OVER 1.27µm - 2.54µm NICKEL.
- TYPE E:
0.38µm MIN. GOLD IN SELECTED AREA & 3.0µm MIN. TIN IN SELECTED AREA OVER 1.3µm MIN. NICKEL OVERALL.
- TYPE F:
0.76µm MIN. GOLD IN SELECTED AREA. & 3.0µm MIN. TIN IN SELECTED AREA OVER 1.3µm MIN. NICKEL OVERALL.
- TYPE G:
0.05 -0.10µm GOLD FLASH IN SELECTED AREA & 3.0µm MIN. TIN IN SELECTED AREA OVER 1.3µm MIN. NICKEL OVERALL.

VOIDED OPTIONS

NO OF CKTS	HSG CKT SIZE	VOIDED PART NUMBER	VOID POSITION	PLATING TYPE
9	10	90130-8190	3	A
9	10	90130-8309	2	F
9	10	90130-8311	1	F
11	12	90130-8212	12	E
11	12	90130-8213	2	E
11	12	90130-8313	2	F
11	12	90130-8191	3	A

THIS DRAWING CONTAINS INFORMATION THAT IS PROPRIETARY TO MOLEX ELECTRONIC TECHNOLOGIES, LLC AND SHOULD NOT BE USED WITHOUT WRITTEN PERMISSION		CURRENT REV DESC:		molex	
DIMENSION UNITS	SCALE	EC NO: 618066			
MM/IN	NTS	DRWN: NMANE02 2019/05/28		C-GRID III	
GENERAL TOLERANCES (UNLESS SPECIFIED)		CHK'D: NMANE02 2019/05/28		DUAL ROW STRAIGHT SHROUDED HEADER	
4 PLACES ±	±	APPR: MRAMAKRISHNA 2019/06/07		PRODUCT CUSTOMER DRAWING	
3 PLACES ±	± 0.004	INITIAL REVISION:		DOCUMENT NUMBER	
2 PLACES ±	± 0.1	DRWN: KS 1988/08/23		SDA-90130	
1 PLACE ±	±	APPR: MLONG 2010/02/19		DOC TYPE	
0 PLACES ±	±	DRAFT WHERE APPLICABLE MUST REMAIN WITHIN DIMENSIONS		001	
ANGULAR TOL ± 0.5°		THIRD ANGLE PROJECTION		DOC PART	
		DRAWING		REVISION	
		A3-SIZE		CA4	
		SERIES		MATERIAL NUMBER	
		90130		CUSTOMER	
		SEE TABLE		GENERAL MARKET	
				SHEET NUMBER	
				2 OF 4	

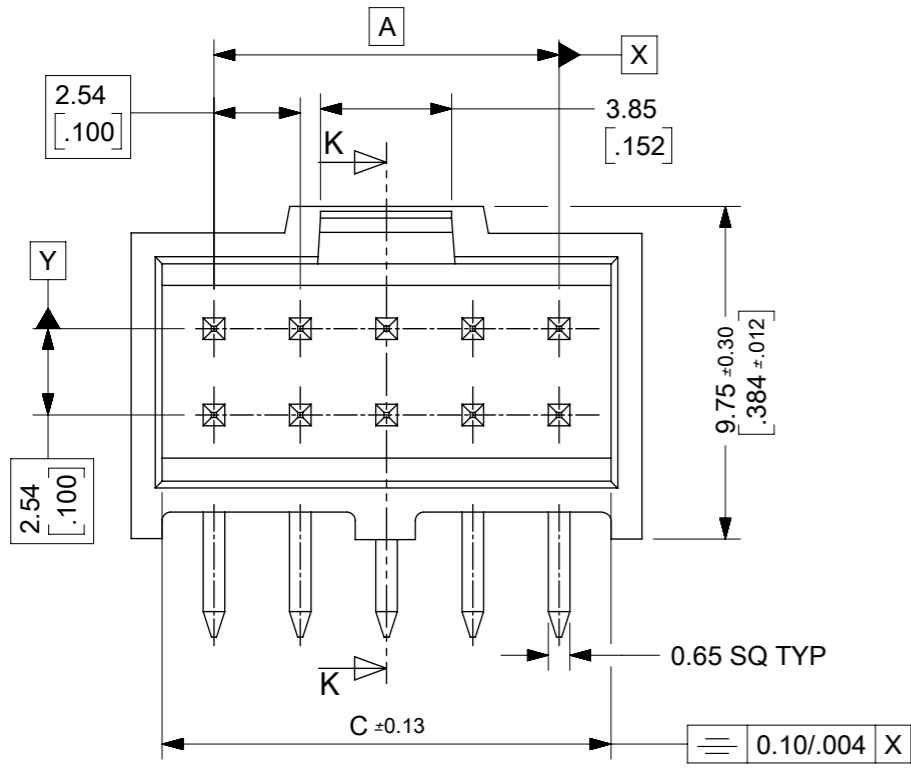

VERSION FULLY LOADED

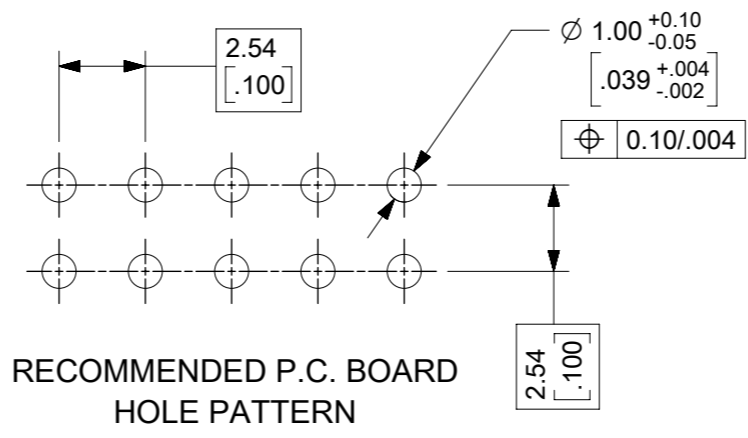

RECOMMENDED P.C. BOARD HOLE PATTERN

CKT	DIM A	DIM B	DIM C
6	(5.08)/ .200	(9.96)/ .392	(8.12)/ .320
8	(7.62)/ .300	(12.50)/ .492	(10.66)/ .420
10	(10.16)/ .400	(15.04)/ .592	(13.20)/ .520
12	(12.70)/ .500	(17.58)/ .692	(15.74)/ .620
14	(15.24)/ .600	(20.12)/ .792	(18.28)/ .720
16	(17.78)/ .700	(22.66)/ .892	(20.82)/ .820
18	(20.32)/ .800	(25.20)/ .992	(23.36)/ .920
20	(22.86)/ .900	(27.74)/ 1.092	(25.90)/ 1.020
22	(25.40)/ 1.000	(30.28)/ 1.192	(28.44)/ 1.120
24	(27.94)/ 1.100	(32.82)/ 1.292	(30.98)/ 1.220
26	(30.48)/ 1.200	(35.36)/ 1.392	(33.52)/ 1.320
28	(33.02)/ 1.300	(37.90)/ 1.492	(36.06)/ 1.420
30	(35.56)/ 1.400	(40.44)/ 1.592	(38.60)/ 1.520
32	(38.10)/ 1.500	(42.98)/ 1.692	(41.15)/ 1.620
34	(40.64)/ 1.600	(45.52)/ 1.792	(43.68)/ 1.720
36	(43.18)/ 1.700	(48.06)/ 1.892	(46.22)/ 1.820
38	(45.72)/ 1.800	(50.60)/ 1.992	(48.76)/ 1.920
40	(48.26)/ 1.900	(53.14)/ 2.092	(51.30)/ 2.020
42	(50.80)/ 2.000	(55.68)/ 2.192	(53.84)/ 2.120
44	(53.34)/ 2.100	(58.22)/ 2.292	(56.38)/ 2.220
46	(55.88)/ 2.200	(60.76)/ 2.392	(58.92)/ 2.320
48	(58.42)/ 2.300	(63.30)/ 2.492	(61.46)/ 2.420
50	(60.96)/ 2.400	(65.84)/ 2.592	(64.00)/ 2.520
52	(63.50)/ 2.500	(68.38)/ 2.692	(66.54)/ 2.620
54	(66.04)/ 2.600	(70.92)/ 2.792	(69.08)/ 2.720
56	(68.58)/ 2.700	(73.46)/ 2.892	(71.62)/ 2.820
58	(71.12)/ 2.800	(76.00)/ 2.992	(74.16)/ 2.920
60	(73.66)/ 2.900	(78.54)/ 3.092	(76.70)/ 3.020
62	(76.20)/ 3.000	(81.08)/ 3.192	(79.24)/ 3.120
64	(78.74)/ 3.100	(83.62)/ 3.292	(81.78)/ 3.220
66	(81.28)/ 3.200	(86.16)/ 3.392	(84.32)/ 3.320
68	(83.82)/ 3.300	(88.70)/ 3.492	(86.86)/ 3.420

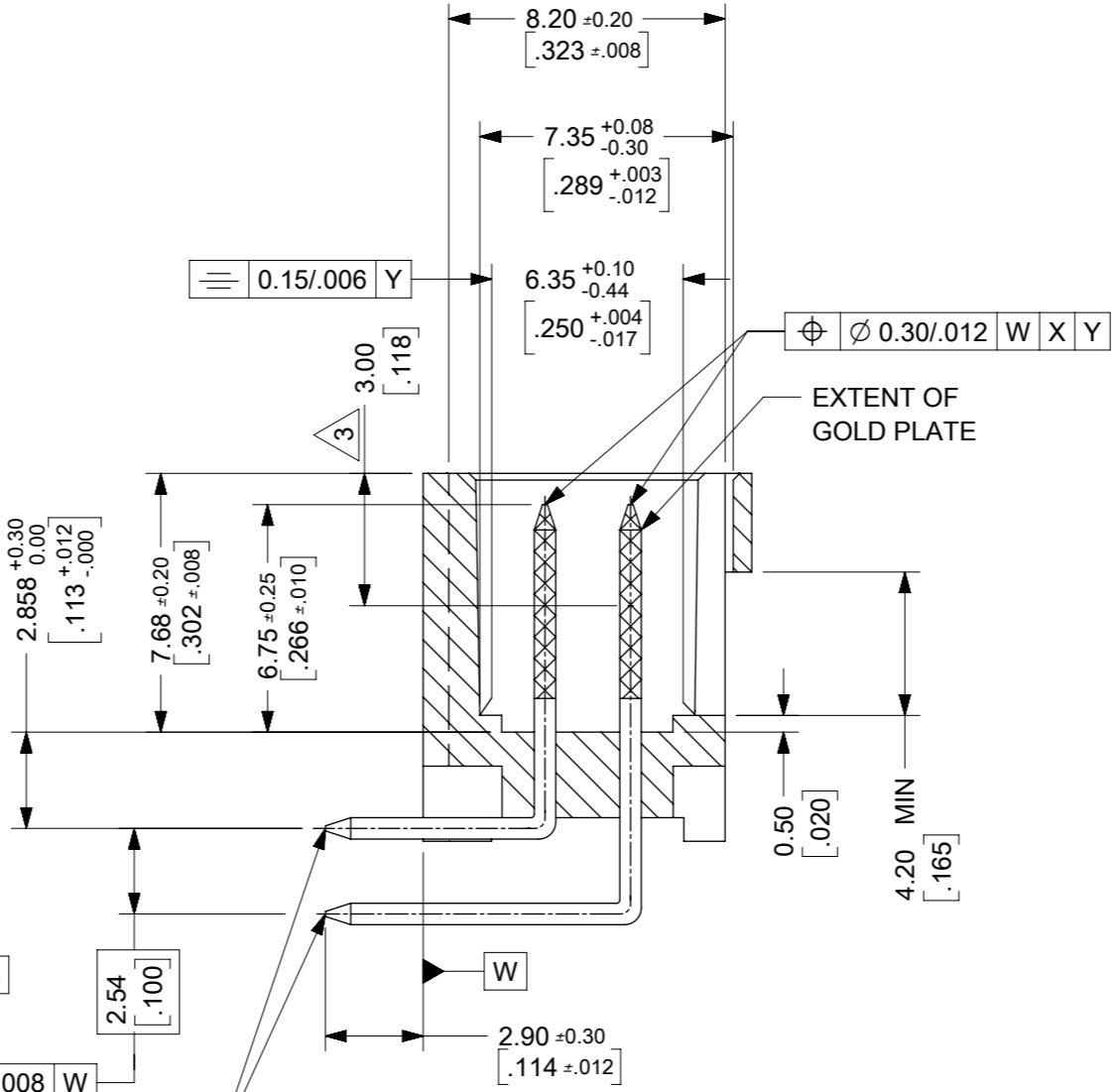
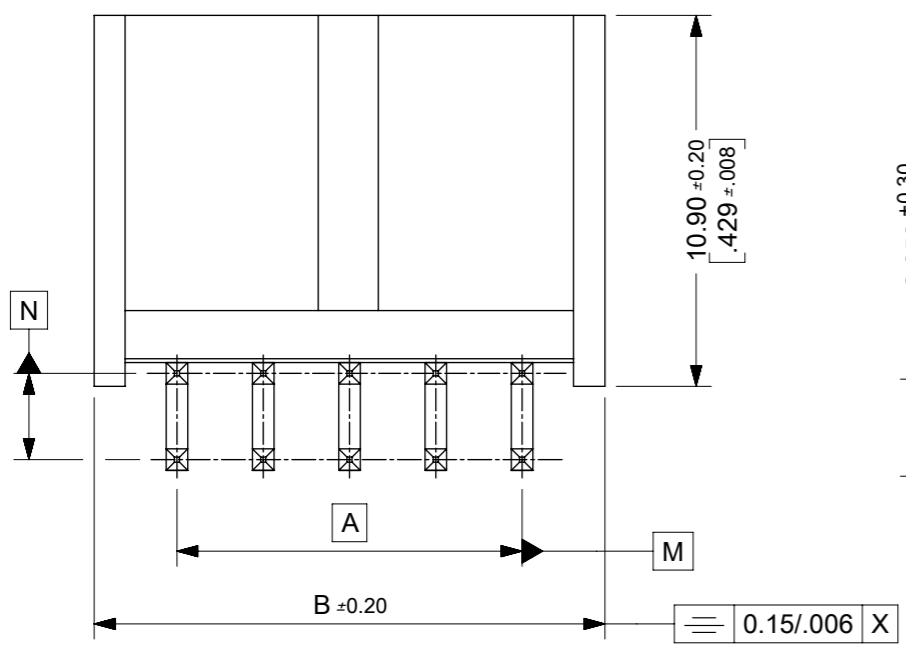

SECTION K-K

- NOTES :
- MATERIAL:-
 - PIN:- (0.65)/.0255 SQ. BRASS WIRE.
 - HOUSING:- 15% GLASS FILLED POLYESTER
 - UL 94 V-0 COLOUR BLACK
 - FOR PLATING VERSIONS AND VOID VERSIONS SEE SHEET 2.
 - MEASUREMENT POINT FOR MINIMUM PLATING THICKNESS.
 - FOR PRODUCT SPEC SEE PS-99020-0001
 - RECOMMENDED PCB THICKNESS: 1.60mm

THIS DRAWING CONTAINS INFORMATION THAT IS PROPRIETARY TO MOLEX ELECTRONIC TECHNOLOGIES, LLC AND SHOULD NOT BE USED WITHOUT WRITTEN PERMISSION

DIMENSION UNITS MM/IN	SCALE NTS	CURRENT REV DESC:		molex				
GENERAL TOLERANCES (UNLESS SPECIFIED)		EC NO: 618066						C-GRID III DUAL ROW STRAIGHT SHROUDED HEADER
4 PLACES ±	MM INCH	DRWN: NMANE02	2019/05/28	PRODUCT CUSTOMER DRAWING				
3 PLACES ±	± 0.004	CHK'D: NMANE02	2019/05/28	DOCUMENT NUMBER				
2 PLACES ±	0.1 ±	APPR: MRAMAKRISHNA	2019/06/07	SDA-90130		DOC TYPE	DOC PART	REVISION
1 PLACE ±	±	INITIAL REVISION:		PSD 001 CA4				
0 PLACES ±	±	DRWN: KS	1988/08/23	MATERIAL NUMBER				
ANGULAR TOL ± 0.5°	±	APPR: MLONG	2010/02/19	SEE TABLE		CUSTOMER		SHEET NUMBER
DRAFT WHERE APPLICABLE MUST REMAIN WITHIN DIMENSIONS		THIRD ANGLE PROJECTION	DRAWING	SERIES	GENERAL MARKET		3 OF 4	

VERSION FULLY LOADED					
NO OF CKTS	HSG CKT SIZE	PART NUMBER			
		PLATING TYPE A	PLATING TYPE E	PLATING TYPE F	PLATING TYPE G
6	6	90130-X106	90130-X206	90130-X306	90130-X406
8	8	90130-X108	90130-X208	90130-X308	90130-X408
10	10	90130-X110	90130-X210	90130-X310	90130-X410
12	12	90130-X112	90130-X212	90130-X312	90130-X412
14	14	90130-X114	90130-X214	90130-X314	90130-X414
16	16	90130-X116	90130-X216	90130-X316	90130-X416
18	18	90130-X118	90130-X218	90130-X318	90130-X418
20	20	90130-X120	90130-X220	90130-X320	90130-X420
22	22	90130-X122	90130-X222	90130-X322	90130-X422
24	24	90130-X124	90130-X224	90130-X324	90130-X424
26	26	90130-X126	90130-X226	90130-X326	90130-X426
28	28	90130-X128	90130-X228	90130-X328	90130-X428
30	30	90130-X130	90130-X230	90130-X330	90130-X430
32	32	90130-X132	90130-X232	90130-X332	90130-X432
34	34	90130-X134	90130-X234	90130-X334	90130-X434
36	36	90130-X136	90130-X236	90130-X336	90130-X436
38	38	90130-X138	90130-X238	90130-X338	90130-X438
40	40	90130-X140	90130-X240	90130-X340	90130-X440
42	42	90130-X142	90130-X242	90130-X342	90130-X442
44	44	90130-X144	90130-X244	90130-X344	90130-X444
46	46	90130-X146	90130-X246	90130-X346	90130-X446
48	48	90130-X148	90130-X248	90130-X348	90130-X448
50	50	90130-X150	90130-X250	90130-X350	90130-X450
52	52	90130-X152	90130-X252	90130-X352	90130-X452
54	54	90130-X154	90130-X254	90130-X354	90130-X454
56	56	90130-X156	90130-X256	90130-X356	90130-X456
58	58	90130-X158	90130-X258	90130-X358	90130-X458
60	60	90130-X160	90130-X260	90130-X360	90130-X460
62	62	90130-X162	90130-X262	90130-X362	90130-X462
64	64	90130-X164	90130-X264	90130-X364	90130-X464
66	66	90130-X166	90130-X266	90130-X366	90130-X466
68	68	90130-X168	90130-X268	90130-X368	90130-X468

NOTES :

- 1. FOR ASSEMBLY, SEE SHEET 1.
- 2. REFER TO LEGEND FOR PLATING OPTIONS.

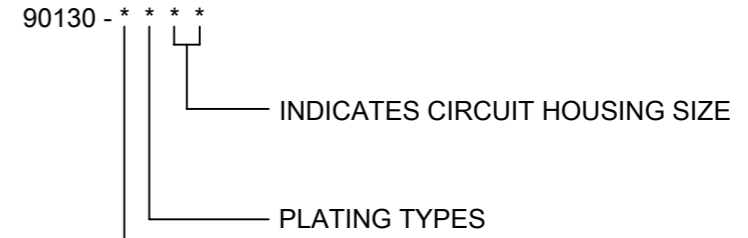

STYLE: - 3. RIGHT ANGLE VERSION

- 1 - TYPE A:
3.0µm MIN. TIN OVER 1.27µm - 2.54µm NICKEL.
- 2 - TYPE E:
0.38µm MIN. GOLD IN SELECTED AREA & 3.0µm MIN. TIN IN SELECTED AREA OVER 1.3µm MIN. NICKEL OVERALL.
- 3 - TYPE F:
0.76µm MIN. GOLD IN SELECTED AREA. & 3.0µm MIN. TIN IN SELECTED AREA OVER 1.3µm MIN. NICKEL OVERALL.
- 4 - TYPE G:
0.05 -0.10µm GOLD FLASH IN SELECTED AREA & 3.0µm MIN. TIN IN SELECTED AREA OVER 1.3µm MIN. NICKEL OVERALL.

THIS DRAWING CONTAINS INFORMATION THAT IS PROPRIETARY TO MOLEX ELECTRONIC TECHNOLOGIES, LLC AND SHOULD NOT BE USED WITHOUT WRITTEN PERMISSION									
DIMENSION UNITS		SCALE		CURRENT REV DESC:					
MM/IN		NTS							
GENERAL TOLERANCES (UNLESS SPECIFIED)				EC NO: 618066		C-GRID III		DUAL ROW STRAIGHT SHROUDED HEADER	
4 PLACES ±		±		DRWN: NMANE02		2019/05/28			
3 PLACES ±		± 0.004		CHK'D: NMANE02		2019/05/28			
2 PLACES ±		0.1		APPR: MRAMAKRISHNA		2019/06/07		PRODUCT CUSTOMER DRAWING	
1 PLACE ±		±		INITIAL REVISION:				DOCUMENT NUMBER	
0 PLACES ±		±		DRWN: KS		1988/08/23		SDA-90130	
ANGULAR TOL ±		0.5°		APPR: MLONG		2010/02/19		PSD 001 CA4	
DRAFT WHERE APPLICABLE MUST REMAIN WITHIN DIMENSIONS				THIRD ANGLE PROJECTION		DRAWING		SERIES	
						A3-SIZE		90130	
				MATERIAL NUMBER		CUSTOMER		SHEET NUMBER	
				SEE TABLE		GENERAL MARKET		4 OF 4	

Looking for pricing, stock, or lifecycle information?

Click below to explore more details on WIN SOURCE:

 [View 901301212 on WIN SOURCE](#)

 [Molex, LLC Information](#)

Optimize Your Supply Chain with WIN SOURCE Solutions

-  Global Sourcing Solution
-  Obsolete Management
-  Cost Control Management
-  Shortage Management
-  Alternative Solution
-  Excess Inventory Management