



**THE DATASHEET OF
MLX10407EDF-AAA-000-RE**



FEATURES

- * Supply voltage up to 12 V.
- * Interface directly with 5 V CMOS logic μ P.
- * Serial link.
- * can drive
 - two actuators 360°
 - three actuators 90°
- * open circuit or short circuit detection of the drivers outputs.
- * Small size (SO24 package).

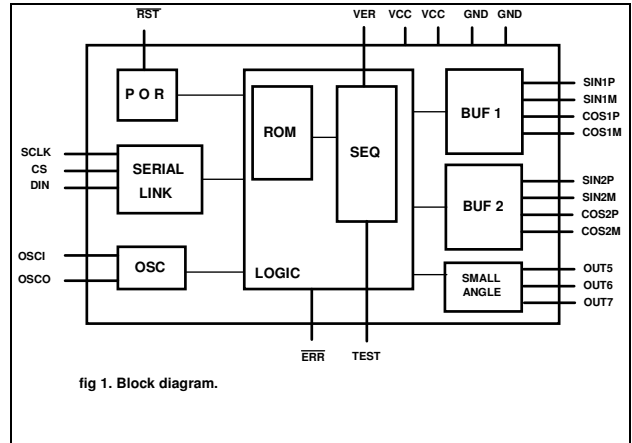

The 10407 is a μ P peripheral for logometers control using SIN/COS PWM commands. The circuit controls two independant sets of CMOS power bridges. A ten bits angle is displayed with a 9 bits per quadrant resolution PWM whose frequency is set by a crystal oscillator. A power-on self test detects open or short-circuits outputs for each logometer and a real time angle tracking avoids display errors. The 10407 can also drive three small angle logometers (90°). The communication with the μ P is done via a three wires serial link. The 10407 outputs an error status on a special pin.

Ordering Code

Product Code	Temperature Code	Package Code	Option Code	Packing Form Code
MLX10407	E	DF	AAA-000	RE

Legend:

Temperature Code: E for Temperature Range -40°C to 85°C
 Package Code: DF for SOIC300Mil
 Packing Form: RE for Reel

Ordering example: MLX10407EDF-AAA-000-RE

PINNING.

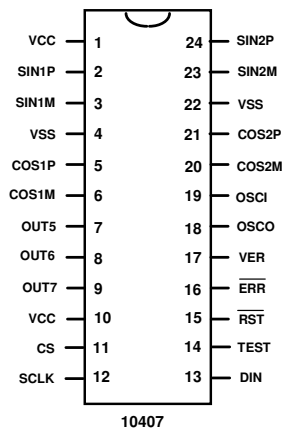

fig.2 Pinning diagram.

SO24 PACKAGE

- Pin 1 : VCC
- Pin 2 : SIN1P, Output buffer (coil 1 Logo1)
- Pin 3 : SIN1M, Output buffer (coil 1 Logo1)
- Pin 4 : VSS
- Pin 5 : COS1P, Output buffer (coil 2 Logo1)
- Pin 6 : COS1M, Output buffer (coil 2 Logo1)
- Pin 7 : OUT5, Output buffer (Logo 3)
- Pin 8 : OUT6, Output buffer (Logo 4)
- Pin 9 : OUT7, Output buffer (Logo 5)
- Pin 10 : VCC
- Pin 11 : CS, Chip select (Schmitt trigger with 300kΩ pull-down)
- Pin 12 : SCLK, Serial clock (Schmitt trigger)
- Pin 13 : DIN, Data IN (Schmitt trigger)
- Pin 14 : TEST input. (1kΩ pull-down)
- Pin 15 : RSTB, external reset (Schmitt trigger)
- Pin 16 : ERRB, Quadrant error output (Open drain)
- Pin 17 : VER, Quadrant verification inhibit
- Pin 18 : OSCO, Crystal oscillator output
- Pin 19 : OSCI, Crystal oscillator input
- Pin 20 : COS2M, Output buffer (coil 2 Logo2)
- Pin 21 : COS2P, Output buffer (coil 2 Logo2)
- Pin 22 : VSS
- Pin 23 : SIN2M, Output buffer (coil 1 Logo2)
- Pin 24 : SIN2P, Output buffer (coil 1 Logo2)

OPERATION.

1) Logometers 360°

Immediately after a reset, the I.C. checks if there is any short-circuit or open circuit on each buffer driver output (This test is not made for outputs 5,6 7). For this test, each buffer is held in a high impedance state and large internal resistances (100kΩ) are sequentially connected on each pair of buffers (note : the actuator coil must be connected on each bridge).

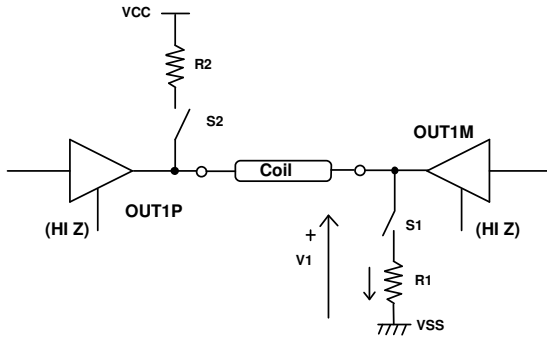

Three tests are done (see fig 3.)

	condition	test for :
Test 1	S1 closed, S2 open	V1 = VSS
Test 2	S1 closed, S2 closed	V1 = VCC/2
Test 3	S1 open, S2 closed	V1 = VCC

fig 3. Test for short-circuits and open circuits.

During the tests the pin ERRB (16) is at logic level 0. Then after the tests have been done ERRB stays at 0 if one (or more) test fails or changes to high impedance state if every thing is OK.

These tests last approximately 4 ms with an oscillator clock frequency of 8 Mhz.

After the test all buffers are at VSS. The I.C. waits for the μP to send an angle/quadrant value and then outputs a PWM signal on every buffer. Every logometer coil is connected in a bridge, so the current Icoil can be either positive or negative. The total drop-out of a bridge is :

$$V_d = |V_{CC} - V_{coil}|$$

The four bridges have the same drop-out for the same current Icoil.

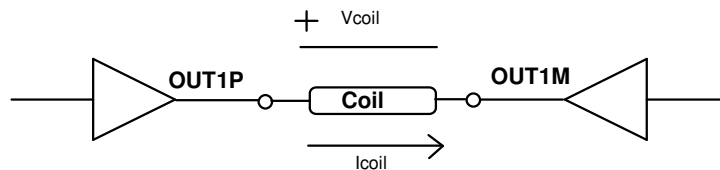

fig 4. One bridge.

2) Logometers 90°

There are three different PWM outputs for Logo 3, Logo 4, Logo 5.

SERIAL LINK.

The μ P outputs the serial clock SCLK, the chip select CS, the data DIN, and receives from the I.C. the error status on pin ERRB(16).

The data sent by the μ P are latched by the 10407 on the rising edge of SCLK.

The 10407 outputs an error status on pin ERRB (16) on the falling edge of SCLK.

When CS = "0" the serial interface of the 10407 is inactive. When CS goes HIGH the 10407 waits for a START BIT and then reads the following 15 bits transmitted by the μ P (see fig 4.)

The START BIT (D_0) must be "1".

The following three bits ($D_1D_2D_3$) are the operation code for the 10407 :

$D_1D_2D_3 = 001 \Rightarrow$ Writing request LOGO1

$D_1D_2D_3 = 011 \Rightarrow$ Writing request LOGO2

$D_1D_2D_3 = 100 \Rightarrow$ Writing request LOGO3

$D_1D_2D_3 = 110 \Rightarrow$ Writing request LOGO4

$D_1D_2D_3 = 101 \Rightarrow$ Writing request LOGO5

Any other codes are reserved for test and will have no effect in normal operation mode.

The following 10 bits ($D_4D_5D_6D_7D_8D_9D_{10}D_{11}D_{12}D_{13}$) are the value of the angle ($D_4 =$ MSB, $D_{13} =$ LSB).

The following two bits ($D_{14}D_{15}$) represent the quadrant ($D_{14} =$ MSB). Note : for Logo1 & 2 only.

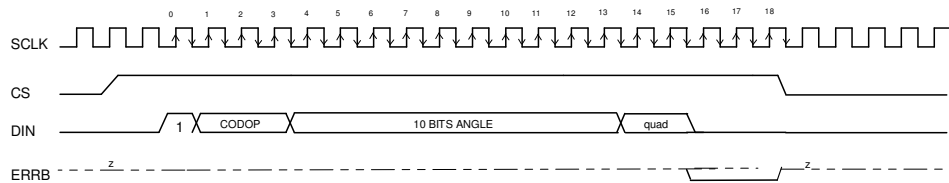

fig 5. Timing diagram serial link.

The 10407 outputs an error status on pin ERRB (16) on the falling edge of SCLK immediately following the transmission of the quadrant LSB.

The pin 16 (ERRB) of the 10407 is driven low if there is no continuity between two consecutive quadrant values sent (for logo1 or logo2). The data is valid till CS is high, then when CS goes low ERRB returns to high impedance state and the error status is lost.

If the μ P has detected an error, it is possible to send data again : the first bit "1" will initiate a new transmission of 15 data bits.

On the HIGH to LOW transition of CS the values of angle and quadrant are stored into the internal registers of the 10407 if :

- The μ P sent a writing request,
- No quadrant error was detected by the 10407.

Otherwise new values of angle and quadrant are not taken into account by the 10407 and the previous values are kept. The μ P must initialize a new transmission with the 10407.



It is possible to make the 10407 store all values of angles and quadrant even if there is an error if the pin 17 (VER) is connected to GND.

PWM GENERATION.

1) Logometers 360° (Logo 1 and Logo 2) :

From the angle value received from the μP (range [0° - 89.8°]) the 10407 generates two PWM (9 bits resolution) :

- the first one represents the sinus PWMSIN,
- the second one is the cosinus PWMCOS.

The 10407 uses a ROM 512x9 which contains the sinus of any angle in the range [0° - 89.8°] (note that the LSB value of the angle is not used).

A value of angle greater than 90° is obtained using different quadrant values :

- Q1 (D₁₄D₁₅ = 00) $\Rightarrow 0^\circ \leq \alpha < 90^\circ$
- Q2 (D₁₄D₁₅ = 01) $\Rightarrow 90^\circ \leq \alpha < 180^\circ$
- Q3 (D₁₄D₁₅ = 10) $\Rightarrow 180^\circ \leq \alpha < 270^\circ$
- Q4 (D₁₄D₁₅ = 11) $\Rightarrow 270^\circ \leq \alpha < 360^\circ$

The PWM are switched to the outputs depending on the value of the quadrant :

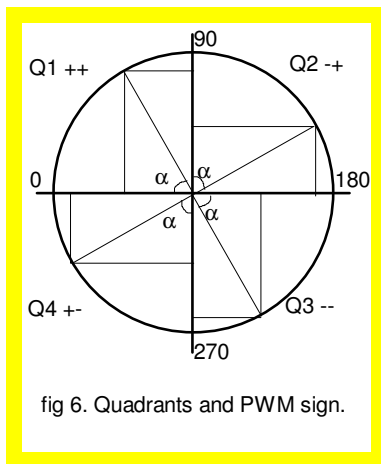

QUADRANT		SIN1M	SIN1P	COS1M	COS1P
D ₁₄	D ₁₅				
0	0	0	PWMSIN	0	PWMCOS
0	1	0	PWMCOS	PWMSIN	0
1	0	PWMSIN	0	PWMCOS	0
1	1	PWMCOS	0	0	PWMSIN

Logometer 1 is driven by outputs SIN1M/P COS1M/P,
Logometer 2 is driven by outputs SIN2M/P COS2M/P.

The PWM frequency is given by :

$$F_{PWM} = F_{OSC} / 512 \quad (F_{OSC} = \text{Crystal oscillator frequency})$$

2) Logometers 90° (Logo1, Logo2, Logo3) :

The value transmitted by the μP is directly the PWM value (D₄D₅D₆D₇D₈D₉D₁₀D₁₁D₁₂), D₄ is MSB and D₁₂ LSB. D₁₃ and Quad bits (D₁₄,D₁₅) are not used.

ABSOLUTE MAXIMUM RATINGS.

parameter	symbol	min.	max.	unit
Storage temperature range	T_{stg}	-40	+150	°C
Operating temperature range	T_{amb}	-40	+85	°C
Supply voltage range (pin 1)	V_{CC}	-0.3	14.0	V
Input voltage range	V_I	-0.3	$V_{CC} + 0.3$	V

ELECTRICAL CHARACTERISTICS.

Tamb = -40 to 85°C, VCC = 5 V to 12 V unless otherwise specified.

parameter	conditions	symbol	min.	typ.	max.	unit
Supply current	Inputs at VCC or VSS No loads on outputs VCC=8.5V T=25°C	ICC			5.5	mA
Maximum power dissipation		PDmax			620	mW
Inputs						
Input capacitance		Cin			10	pF
Pin 11						
Pull-down resistance		Rpd	125		750	kΩ
input voltage LOW		VIL	-0.3		1	V
input voltage HIGH		VIH	4		VCC+0.3	V
Hysteresis	VCC = 8.5 V	VHYS	0.5		2.5	V
Leakage current	pin at VCC or VSS	IL	-1		1	μA
Pin 12,13,14,15,17						
input voltage LOW		VIL	-0.3		1	V
input voltage HIGH		VIH	4		VCC+0.3	V
Hysteresis	VCC = 8.5 V	VHYS	0.5		2.5	V
Leakage current (p12,15,17)	pin at VCC or VSS	IL	-1		1	μA
Pull-down resistance (p14)		Rpd	0.8		1.5	kΩ
Outputs						
Pin 16						
Low level output voltage	IOUT < 500 μA	VOL			0.3	V
High level output leakage current	VOUT = VCC	ILKG			10	μA
Pin 2,3,5,6,20,21,23,24						
Drop-out voltage for each pair of buffers	VCC = 8.5V, Tamb = 25°C Icoil = 30 mA, see fig. 4	Vd			1.6	V
Mismatch of drop-out voltage	VCC = 8.5V, Tamb = 25°C Icoil = 30 mA, see fig. 4	ΔVd			± 50	mV
Pin 7,8,9						
Output voltage low	VCC = 8.5V, Tamb = 25°C Isink = 40mA	VOL		0.6	1.0	V
Output voltage high	VCC = 8.5V, Tamb=25°C Isource = 40mA	VOH	6.8	7.8		V
Oscillator						
Pin 18,19						
input pin capacitance		Cin		10	20	pF

clock frequency	f_{clk}	8	MHz
-----------------	-----------	---	-----

AC ELECTRICAL CHARACTERISTICS.

Parameter	Value	unit
Maximum SCLK input frequency	500	kHz
Setup time DIN to SCLK rising	100	ns
Hold time DIN to SCLK rising	100	ns
Setup time CS high to SCLK rising	100	ns

APPLICATION SCHEMATIC.

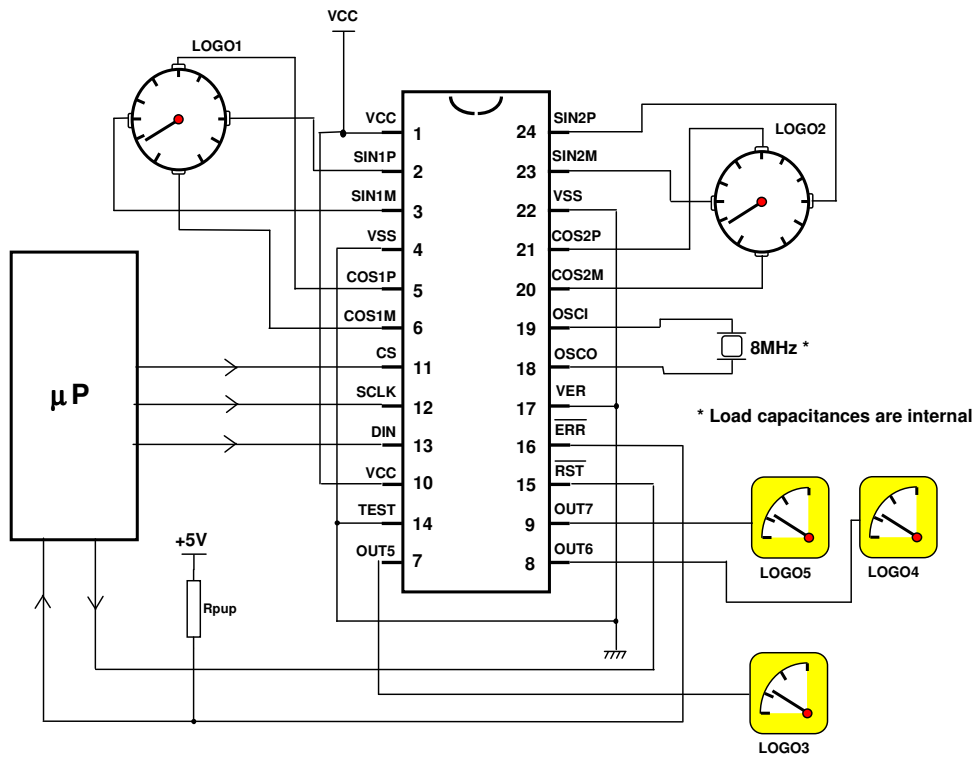

Fig 7. Typical application

Disclaimer

Devices sold by Melexis are covered by the warranty and patent indemnification provisions appearing in its Term of Sale. Melexis makes no warranty, express, statutory, implied, or by description regarding the information set forth herein or regarding the freedom of the described devices from patent infringement. Melexis reserves the right to change specifications and prices at any time and without notice. Therefore, prior to designing this product into a system, it is necessary to check with Melexis for current information. This product is intended for use in normal commercial applications. Applications requiring extended temperature range, unusual environmental requirements, or high reliability applications, such as military, medical life-support or life-sustaining equipment are specifically not recommended without additional processing by Melexis for each application.

The information furnished by Melexis is believed to be correct and accurate. However, Melexis shall not be liable to recipient or any third party for any damages, including but not limited to personal injury, property damage, loss of profits, loss of use, interrupt of business or indirect, special incidental or consequential damages, of any kind, in connection with or arising out of the furnishing, performance or use of the technical data herein. No obligation or liability to recipient or any third party shall arise or flow out of Melexis' rendering of technical or other services.

© 2012 Melexis NV. All rights reserved.

For the latest version of this document, go to our website at
www.melexis.com

Or for additional information contact Melexis Direct:

Europe, Africa, Asia:

Phone: +32 1367 0495

E-mail: sales_europe@melexis.com

America:



Phone: +1 248 306 5400

E-mail: sales_usa@melexis.com

ISO/TS 16949 and ISO14001 Certified

Looking for pricing, stock, or lifecycle information?

Click below to explore more details on WIN SOURCE:

-  [View MLX10407EDF-AAA-000-RE on WIN SOURCE](#)
-  [Melexis Technologies NV Information](#)

Optimize Your Supply Chain with WIN SOURCE Solutions

-  Global Sourcing Solution
-  Obsolete Management
-  Cost Control Management
-  Shortage Management
-  Alternative Solution
-  Excess Inventory Management