



MIC2208

3mm x 3mm 1MHz 3A PWM Buck Regulator

General Description

The Micrel MIC2208 is a high efficiency PWM buck (step-down) regulator that provides up to 3A of output current. The MIC2208 operates at 1MHz and has external compensation that allows a closed loop bandwidth of over 100kHz.

The low on-resistance internal p-channel MOSFET of the MIC2208 allows efficiencies over 94% reduces external component count and eliminates the need for an expensive current sense resistor.

The MIC2208 operates from 2.7V to 5.5V input and the output can be adjusted down to 1V. The devices can operate with a maximum duty cycle of 100% for use in low-dropout conditions.

The MIC2208 is available in the exposed pad 12-pin 3mm x 3mm MLF[®] package with a junction operating range from -40°C to +125°C.

Datasheets and support documentation can be found on Micrel's web site at: www.micrel.com.

Features

- 2.7 to 5.5V supply voltage
- 1MHz PWM mode
- Output current to 3A
- >90% efficiency
- Adjustable output voltage option down to 1V
- Ultra-fast transient response
- External Compensation
- Stable with a wide range of output capacitance
- Fully integrated 5A MOSFET switch
- Micropower shutdown
- Thermal shutdown and current limit protection
- Pb-free 12-pin 3mm x 3mm MLF[®] package
- -40°C to +125°C junction temperature range

Applications

- 5V or 3.3V Point of Load Conversion
- Telecom/Networking Equipment
- Set Top Boxes
- Storage Equipment
- Video Cards

Typical Application

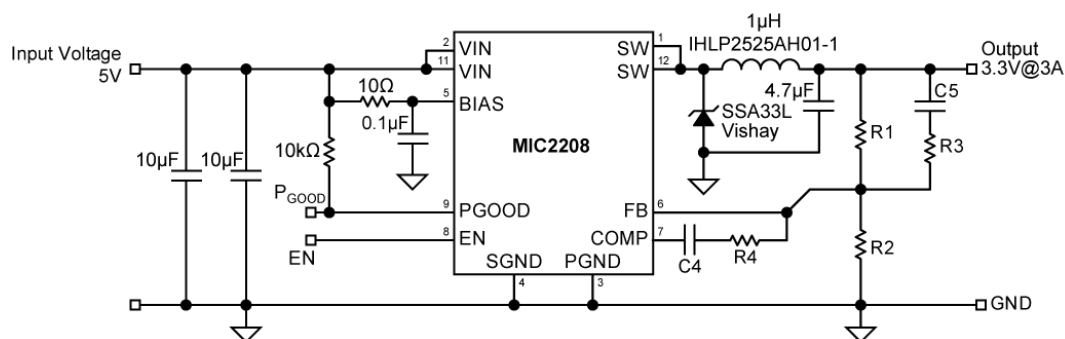

3A 1MHz Buck Regulator

MLF and MicroLeadFrame are registered trademarks of Amkor Technology, Inc.

Micrel Inc. • 2180 Fortune Drive • San Jose, CA 95131 • USA • tel +1 (408) 944-0800 • fax +1 (408) 474-1000 • <http://www.micrel.com>

Ordering Information

Part Number	Voltage	Temperature Range	Package	Lead Finish
MIC2208YML	Adj.	-40° to +125°C	12-Pin 3x3 MLF [®]	Pb-Free

Note:

MLF[®] is GREEN RoHS compliant package. Lead finish is NiPdAu. Mold compound is Halogen Free.

Pin Configuration

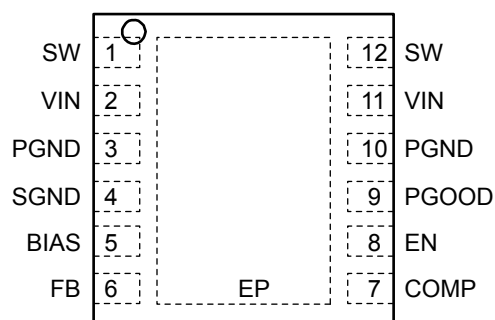

12-Pin 3mm x 3mm MLF[®] (ML)

Pin Description

Pin Number	Pin Name	Pin Function
1, 12	SW	Switch (Output): Internal power P-Channel MOSFET output switch.
2, 11	VIN	Supply Voltage (Input): Supply voltage for the source of the internal P-channel MOSFET and driver. Requires bypass capacitor to GND
3, 10	PGND	Power Ground. Provides the ground return path for the high-side drive current.
4	SGND	Signal Ground. Provides return path for control circuitry and internal reference.
5	BIAS	Internal circuit bias supply. Must be bypassed with a 0.1μF ceramic capacitor to SGND.
6	FB	Feedback. Input to the error amplifier, connect to the external resistor divider network to set the output voltage.
7	COMP	Compensation. This is the internal error amplifier output. Connect external compensation components for type II or type III compensation.
8	EN	Enable (Input). Logic level low will shutdown the device, reducing the current draw to less than 5μA.
9	PGOOD	Power Good. Open drain output that is pulled to ground when the output voltage is within ±7.5% of the set regulation voltage
EP	GND	Connect to ground.

Absolute Maximum Ratings⁽¹⁾

Supply Voltage (V_{IN})	-0.3V to +6V
Output Switch Voltage (V_{SW})	-1V to +6V
Output Switch Current (I_{SW})	10A
Logic Input Voltage (V_{EN})	-0.3V to V_{IN}
Storage Temperature (T_s)	-60°C to 150°C
ESD Rating ⁽³⁾	2kV (HBM)

Operating Ratings⁽²⁾

Supply Voltage (V_{IN})	+2.7V to +5.5V
Logic Input Voltage (V_{EN} , V_{LOWQ})	0V to V_{IN}
Junction Temperature (T_J)	-40°C to +125°C
Junction Thermal Resistance	
3x3 MLF-12 (θ_{JA})	60°C/W

Electrical Characteristics⁽⁴⁾

$V_{IN} = V_{EN} = 3.6V$; $L = 1\mu H$; $C_{OUT} = 4.7\mu F$; $T_A = 25^\circ C$, unless noted. **Bold** values indicate $-40^\circ C < T_J < +125^\circ C$.

Parameter	Condition	Min	Typ	Max	Units
Supply Voltage Range		2.7		5.5	V
Under-Voltage Lockout Threshold	(turn-on)	2.45	2.55	2.65	V
UVLO Hysteresis			100		mV
Quiescent Current	$V_{FB} = 0.9 * V_{NOM}$ (not switching)		720	950	μA
Shutdown Current	$V_{EN} = 0V$		0.1	5	μA
[Adjustable] Feedback Voltage	$\pm 1\%$ $\pm 2\%$ (over temperature)	0.99 0.98	1	1.01 1.02	V V
FB pin input current			1	100	nA
Current Limit in PWM Mode	$V_{FB} = 0.9 * V_{NOM}$		8	10	A
Output Voltage Line Regulation	$V_{OUT} > 2.2V$; $V_{IN} = V_{OUT} + 500mV$ to 5.5V; $I_{LOAD} = 20mA$ $V_{OUT} < 2.2V$; $V_{IN} = 2.7V$ to 5.5V; $I_{LOAD} = 20mA$		0.13		%
Output Voltage Load Regulation	$20mA < I_{LOAD} < 3A$		0.2	1	%
PWM Switch ON-Resistance	$I_{SW} = 50mA$ $V_{FB} = 0.7V_{FB_NOM}$ (High Side Switch)		95	20 300	m Ω m Ω
Oscillator Frequency		0.9	1	1.1	MHz
Enable Threshold		0.5	0.85	1.3	V
Enable Input Current			0.1	2	μA
Soft Start Time	$V_{OUT} = 10\%$ to $V_{OUT} = 90\%$		450		μs
Over-Temperature Shutdown			160		$^\circ C$
over-Temperature Hysteresis			20		$^\circ C$
Power Good Range			± 7	± 10	%
Power Good Resistance	I_{PGOOD}		145	250	Ω

Notes:

1. Exceeding the absolute maximum rating may damage the device.
2. The device is not guaranteed to function outside its operating rating.
3. Devices are ESD sensitive. Handling precautions recommended. Human body model, 1.5k Ω in series with 100pF.
4. Specification for packaged product only.

Typical Characteristics

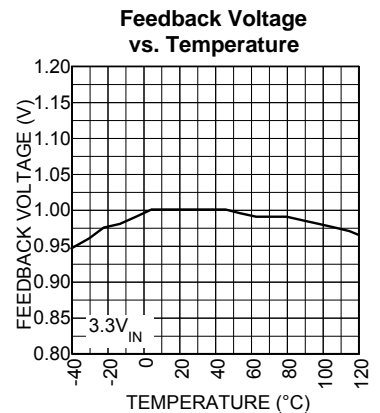
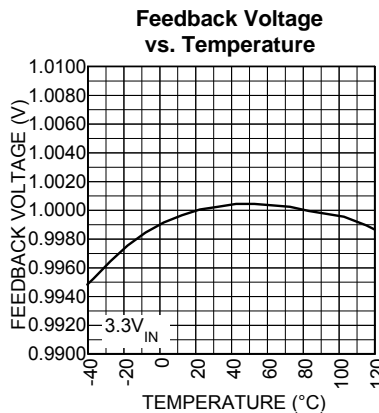
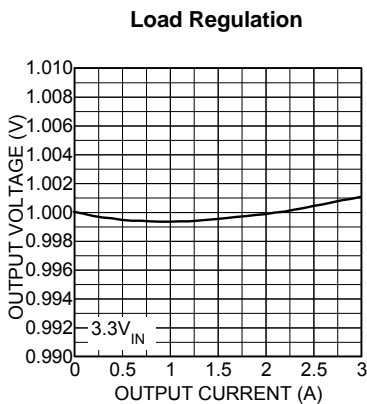
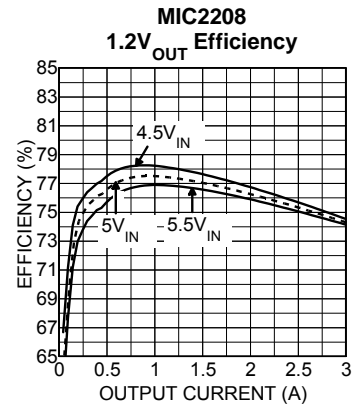
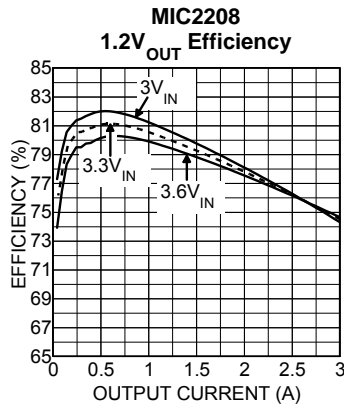
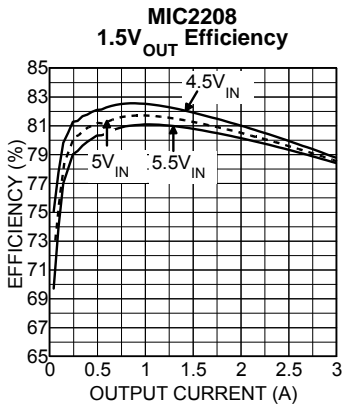
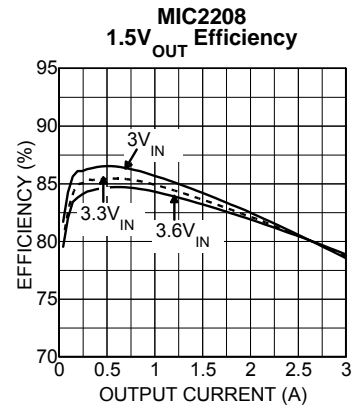
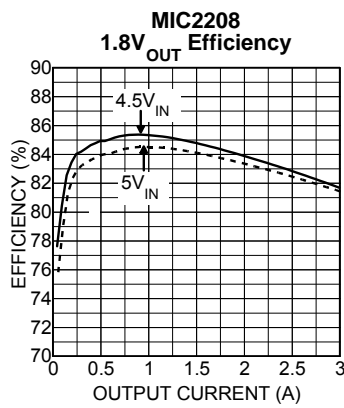
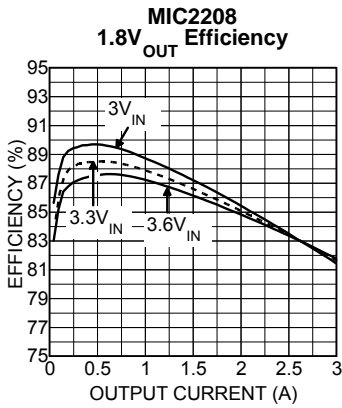
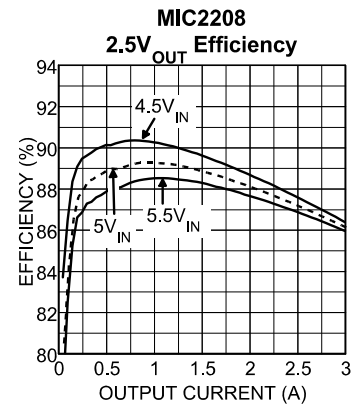
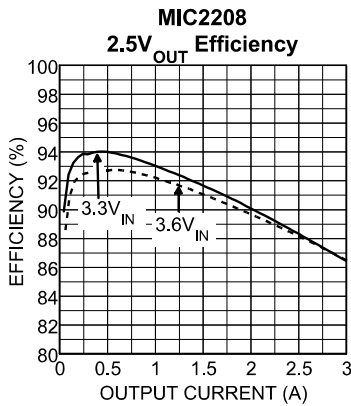
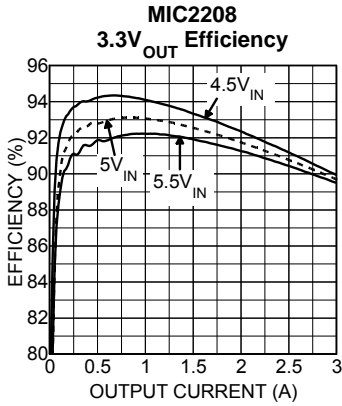

Typical Characteristics (continued)

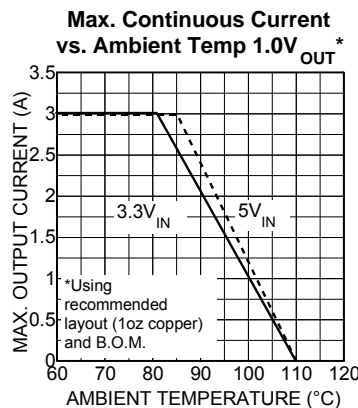
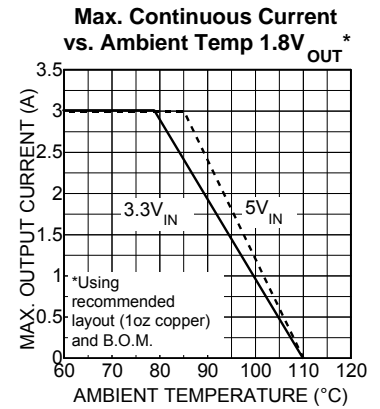
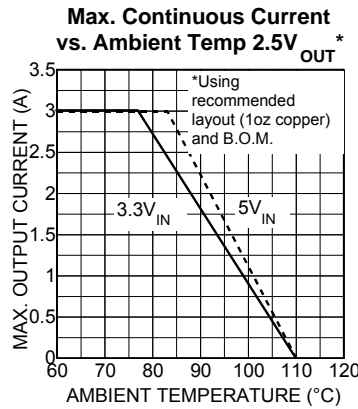
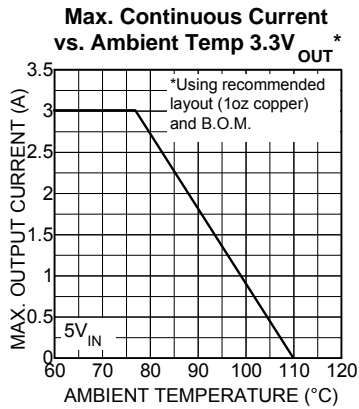
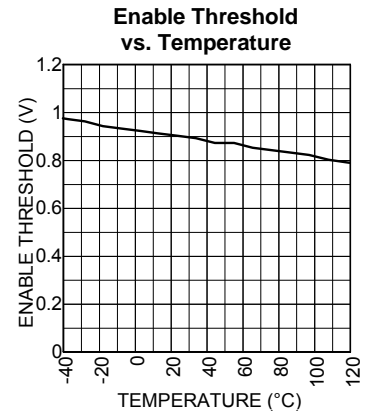
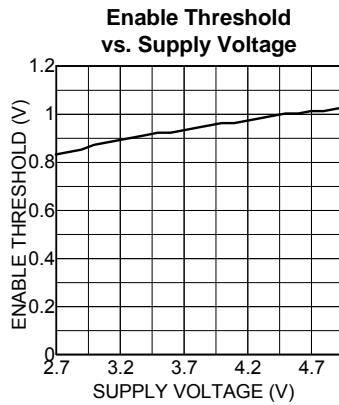
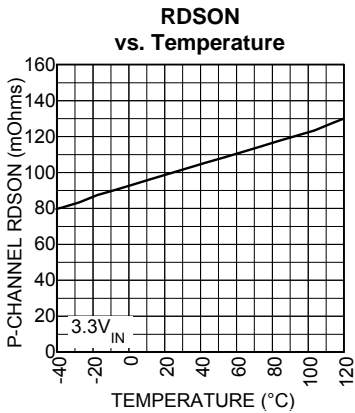
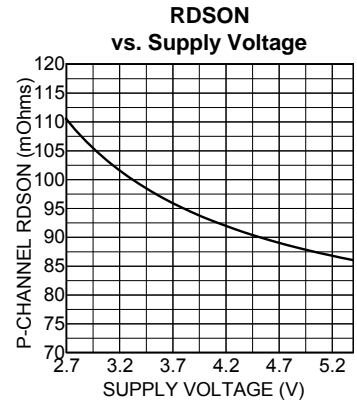
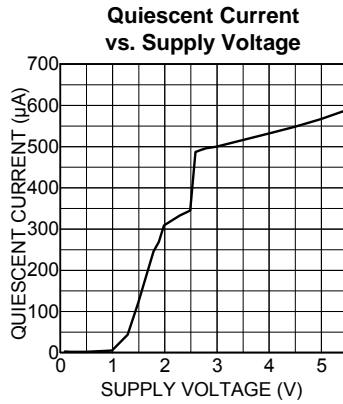
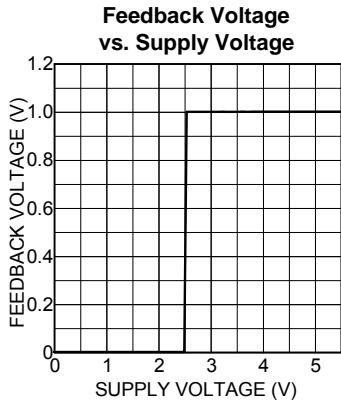

Functional Characteristics

Continuous Operation

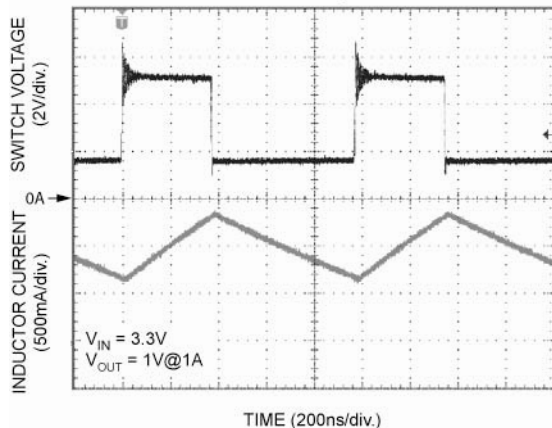

Discontinuous Operation

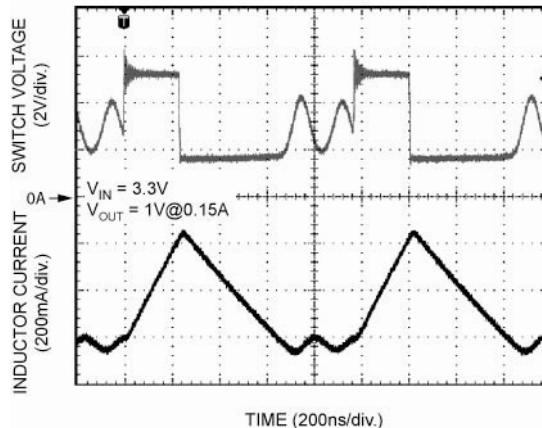

Transient Response

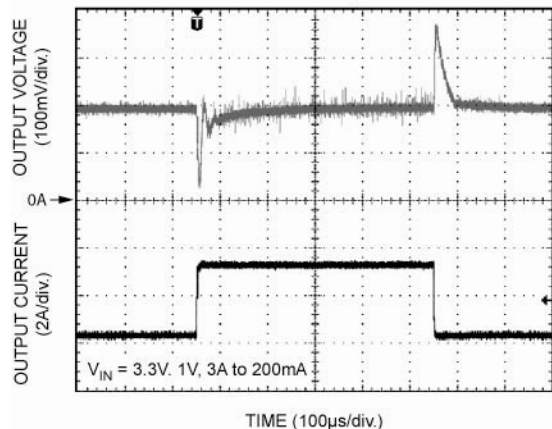

Enable Response

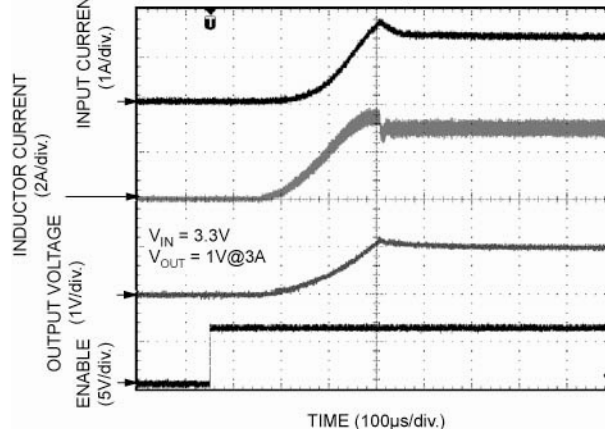

Power Good

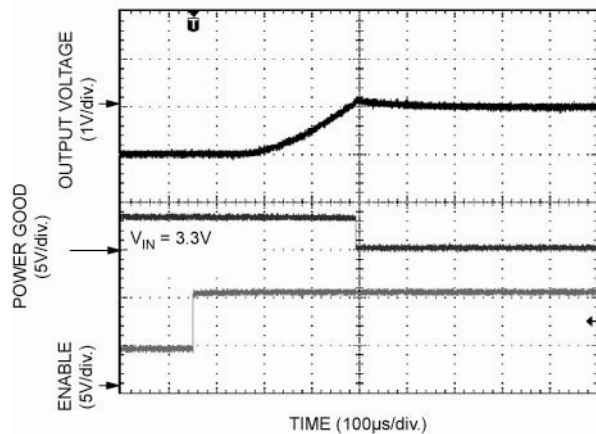

Power Good

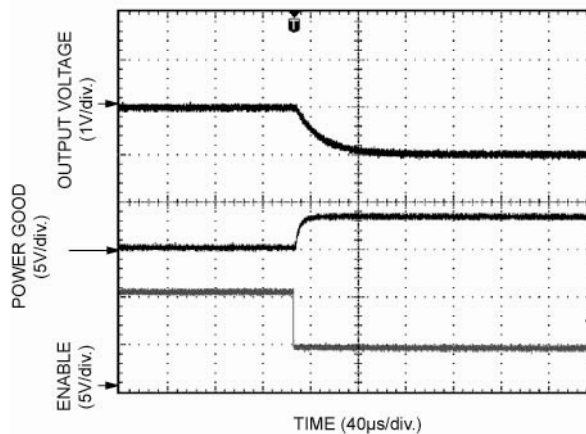

Functional Diagram

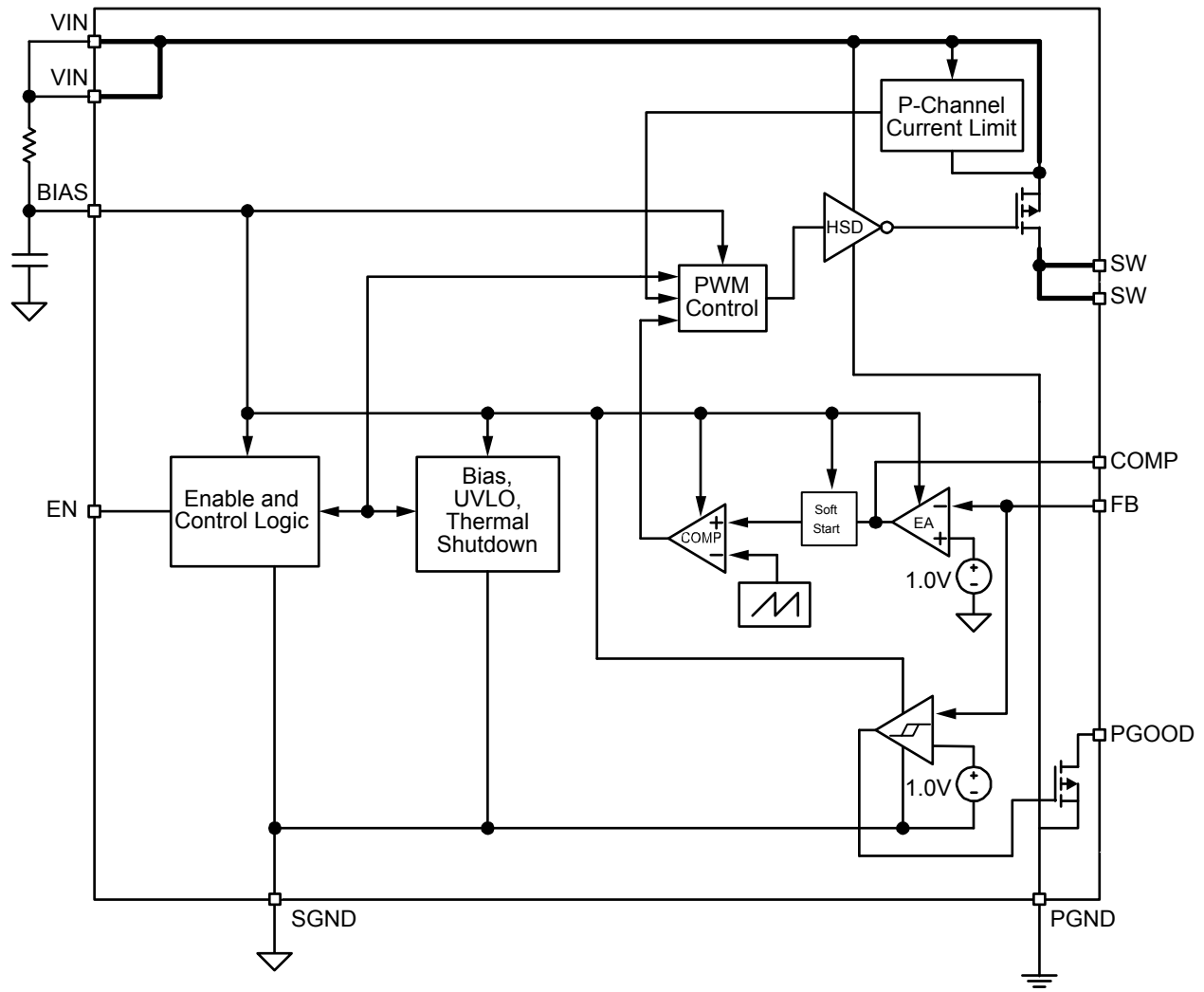

MIC2208 Block Diagram

Pin Description

VIN

Two pins for VIN provide power to the source of the internal P-channel MOSFET along with the current limiting sensing. The VIN operating voltage range is from 2.7V to 5.5V. Due to the high switching speeds, a 10 μ F capacitor is recommended close to VIN and the power ground (PGND) for each pin for bypassing. Please refer to layout recommendations.

BIAS

The bias (BIAS) provides power to the internal reference and control sections of the MIC2208. A 10 Ω resistor from VIN to BIAS and a 0.1 μ F from BIAS to SGND is required for clean operation.

EN

The enable pin provides a logic level control of the output. In the off state, supply current of the device is greatly reduced (typically <1 μ A). Do not drive the enable pin above the supply voltage.

FB

The feedback pin (FB) provides the control path to control the output. For adjustable versions, a resistor divider connecting the feedback to the output is used to adjust the desired output voltage. The output voltage is calculated as follows:

$$V_{OUT} = V_{REF} \times \left(\frac{R1}{R2} + 1 \right)$$

where VREF is equal to 1.0V.

COMP

The COMP pin is the output of the internal error amplifier. This pin is used to compensate the MIC2208 for stability over a varying range of external components. Refer to the compensation section of the datasheet for determining necessary component values.

SW

The switch (SW) pin connects directly to the inductor and provides the switching current necessary to operate in PWM mode. Due to the high speed switching on this pin, the switch node should be routed away from sensitive nodes. This pin also connects to the cathode of the free-wheeling diode.

PGOOD

Power good is an open drain pull down that indicates when the output voltage has reached regulation. For a power good low, the output voltage is within $\pm 10\%$ of the set regulation voltage. For output voltages greater or less than 10%, the PGOOD pin is high. This should be connected to the input supply through a pull up resistor. A delay can be added by placing a capacitor from PGOOD to ground.

PGND

Power ground (PGND) is the ground path for the MOSFET drive current. The current loop for the power ground should be as small as possible and separate from the Analog ground (AGND) loop. Refer to the layout considerations for more details.

SGND

Signal ground (SGND) is the ground path for the biasing and control circuitry. The current loop for the signal ground should be separate from the power ground (PGND) loop. Refer to the layout considerations for more details.

Application Information

The MIC2208 is a 3A PWM non-synchronous buck regulator. By switching an input voltage supply, and filtering the switched voltage through an Inductor and capacitor, a regulated DC voltage is obtained. Figure 1 shows a simplified example of a non-synchronous buck converter.

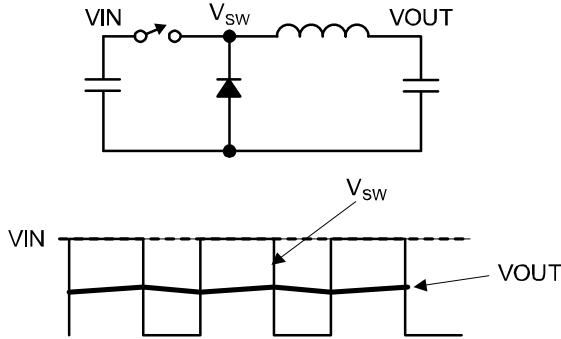

Figure 1.

For a non-synchronous buck converter, there are two modes of operation; continuous and discontinuous. Continuous or discontinuous refer to the inductor current. If current is continuously flowing through the inductor throughout the switching cycle, it is in continuous operation. If the inductor current drops to zero during the off time, it is in discontinuous operation. Critically continuous is the point where any decrease in output current will cause it to enter discontinuous operation. The critically continuous load current can be calculated as follows:

$$I_{OUT} = \frac{\left[V_{OUT} - \frac{V_{OUT}^2}{V_{IN}} \right]}{1\text{MHz} \times 2 \times L}$$

Continuous or discontinuous operation determines how we calculate peak inductor current.

Continuous Operation

Figure 2 illustrates the switch voltage and inductor current during continuous operation.

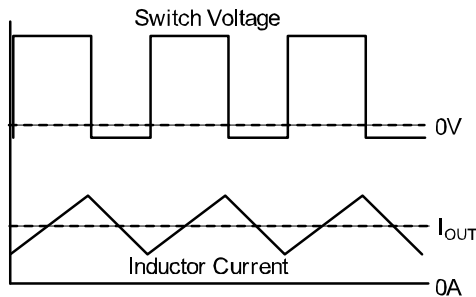

Figure 2. Continuous Operation

The output voltage is regulated by pulse width modulating (PWM) the switch voltage to the average required output voltage. The switching can be broken up into two cycles; On and Off.

During the on-time, the high side switch is turned on, current flows from the input supply through the inductor and to the output. The inductor current is

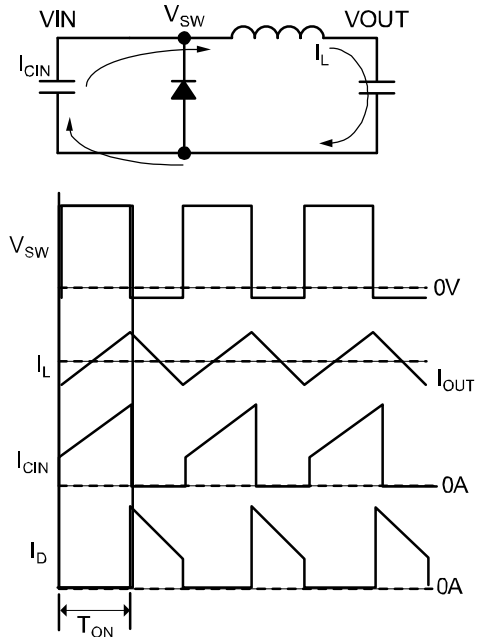

Figure 3. On-Time

charged at the rate:

$$\frac{(V_{IN} - V_{OUT})}{L}$$

To determine the total on-time, or time at which the inductor charges, the duty cycle needs to be calculated. The duty cycle can be calculated as:

$$D = \frac{V_{OUT}}{V_{IN}}$$

and the On time is:

$$T_{ON} = \frac{D}{1\text{MHz}}$$

Therefore, peak to peak ripple current is:

$$I_{PK-PK} = \frac{(V_{IN} - V_{OUT}) \times \frac{V_{OUT}}{V_{IN}}}{1\text{MHz} \times L}$$

Figure 4 demonstrates the off-time. During the off-time, the high-side internal P-channel MOSFET turns off. Since the current in the inductor has to discharge, the current flows through the free-wheeling Schottky diode to the output. In this case, the inductor discharge rate is

(where V_D is the diode forward voltage):

$$T_{OFF} = \frac{1-D}{1\text{MHz}}$$

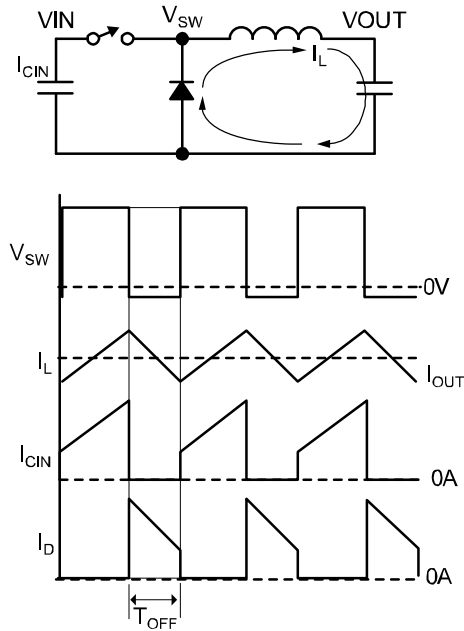

Figure 4. Off-Time

Discontinuous Operation

Discontinuous operation is when the inductor current discharges to zero during the off cycle. Figure 5 demonstrates the switch voltage and inductor currents during discontinuous operation.

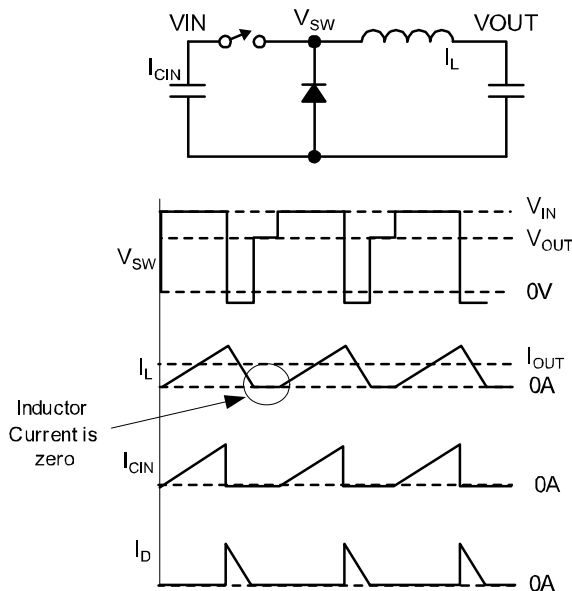

Figure 5. Discontinuous Operation

When the inductor current (I_L) has completely discharged, the voltage on the switch node rings at the frequency determined by the parasitic capacitance and the inductor value. In Figure 5, it is drawn as a DC voltage, but to see actual operation (with ringing and all) refer to the functional characteristics.

Discontinuous mode of operation has the advantage over full PWM in that at light loads, the MIC2208 will skip pulses as necessary, reducing gate drive losses, drastically improving light load efficiency.

Efficiency Considerations

Calculating the efficiency is as simple as measuring power out and dividing it by the power in:

$$\text{Efficiency} = \frac{P_{OUT}}{P_{IN}} \times 100$$

Where input power (P_{IN}) is:

$$P_{IN} = V_{IN} \times I_{IN}$$

and output power (P_{OUT}) is calculated as:

$$P_{OUT} = V_{OUT} \times I_{OUT}$$

The Efficiency of the MIC2208 is determined by several factors.

- R_{DSON} (Internal P-channel Resistance)
- Diode conduction losses
- Inductor Conduction losses
- Switching losses

R_{DSON} losses are caused by the current flowing through the high side P-channel MOSFET. The amount of power loss can be approximated by:

$$P_{SW} = R_{DSON} \times I_{OUT}^2 \times D$$

where D is the duty cycle.

Since the MIC2208 uses an internal P-channel MOSFET, R_{DSON} losses are inversely proportional to supply voltage. Higher supply voltage yields a higher gate to source voltage, reducing the R_{DSON} , reducing the MOSFET conduction losses. A graph showing typical R_{DSON} vs. input supply voltage can be found in the typical characteristics section of this datasheet.

Diode conduction losses occur due to the forward voltage drop (V_F) and the output current. Diode power losses can be approximated as follows:

$$P_D = V_F \times I_{OUT} \times (1-D)$$

For this reason, the Schottky diode is the rectifier of choice. Using the lowest forward voltage drop will help reduce diode conduction losses, and improve efficiency.

Duty cycle, or the ratio of output voltage-to-input voltage, determines whether the dominant factor in conduction losses will be the internal MOSFET or the Schottky diode. Higher duty cycles place the power losses on the high side switch, and lower duty cycles place the power losses on the schottky diode. Inductor conduction losses

(P_L) can be calculated by multiplying the DC resistance (DCR) times the square of the output current:

$$P_L = \text{DCR} \times I_{\text{OUT}}^2$$

Also, be aware that there are additional core losses associated with switching current in an inductor. Since most inductor manufacturers do not give data on the type of material used, approximating core losses becomes very difficult, so verify inductor temperature rise.

Switching losses occur twice each cycle, when the switch turns on and when the switch turns off. This is caused by a non-ideal world where switching transitions are not instantaneous, and neither are currents. Figure 6 demonstrates (Or exaggerates.) how switching losses due to the transitions dissipate power in the switch.

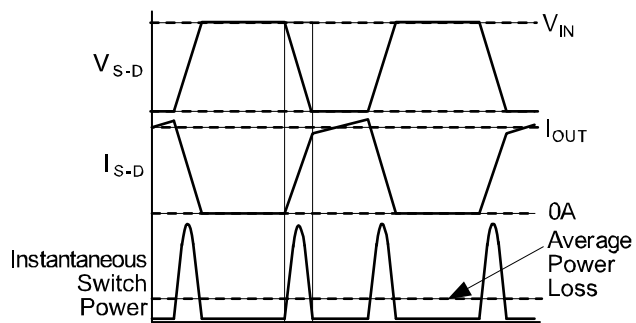

Figure 6. Switching Transition Losses

Normally, when the switch is on, the voltage across the switch is low (virtually zero) and the current through the switch is high. This equates to low power dissipation. When the switch is off, voltage across the switch is high and the current is zero, again with power dissipation being low. During the transitions, the voltage across the switch (V_{S-D}) and the current through the switch (I_{S-D}) are at middle, causing the transition to be the highest instantaneous power point. During continuous mode, these losses are the highest. Also, with higher load currents, these losses are higher. For discontinuous operation, the transition losses only occur during the “off” transition since the “on” transitions there is no current flow through the inductor.

Component Selection

Input Capacitor

A 10 μ F ceramic is recommended on each VIN pin for bypassing. X5R or X7R dielectrics are recommended for the input capacitor. Y5V dielectrics lose most of their capacitance over temperature and are therefore, not recommended. Also, tantalum and electrolytic capacitors alone are not recommended due their reduced RMS current handling, reliability, and ESR increases.

An additional 0.1 μ F is recommended close to the VIN and PGND pins for high frequency filtering. Smaller case size capacitors are recommended due to their lower ESR and ESL. Please refer to layout recommendations for proper layout of the input capacitor.

Inductor Selection

The MIC2208 is designed for use with a 1 μ H inductor. Proper selection should ensure the inductor can handle the maximum average and peak currents required by the load. Maximum current ratings of the inductor are generally given in two methods; permissible DC current and saturation current. Permissible DC current can be rated either for a 40°C temperature rise or a 10% to 20% loss in inductance. Ensure the inductor selected can handle the maximum operating current. When saturation current is specified, make sure that there is enough margin that the peak current will not saturate the inductor.

Diode Selection

Since the MIC2208 is non-synchronous, a free-wheeling diode is required for proper operation. A schottky diode is recommended due to the low forward voltage drop and their fast reverse recovery time. The diode should be rated to be able to handle the average output current. Also, the reverse voltage rating of the diode should exceed the maximum input voltage. The lower the forward voltage drop of the diode the better the efficiency. Please refer to the layout recommendations to minimize switching noise.

Feedback Resistors

The feedback resistor set the output voltage by dividing down the output and sending it to the feedback pin. The feedback voltage is 1.0V. Calculating the set output voltage is as follows:

$$V_{OUT} = V_{FB} \left(\frac{R1}{R2} + 1 \right)$$

Where R1 is the resistor from VOUT to FB and R2 is the resistor from FB to GND. The recommended feedback resistor values for common output voltages is available in the bill of materials on page x. Although the range of

resistance for the FB resistors is very wide, R1 is recommended to be 10K. This minimizes the effect the parasitic capacitance of the FB node.

Bias filter

A small 10 Ω resistor is recommended from the input supply to the bias pin along with a small 0.1 μ F ceramic capacitor from bias-to-ground. This will bypass the high frequency noise generated by the violent switching of high currents from reaching the internal reference and control circuitry. Tantalum and electrolytic capacitors are not recommended for the bias, these types of capacitors lose their ability to filter at high frequencies.

Type II Open Loop Gain Response

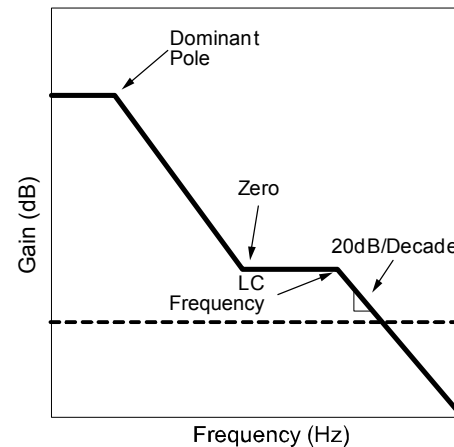

Compensation

The MIC2208 utilizes voltage mode compensation and has the error amplifier pin (COMP) pinned out to allow it to be compensated using external components. This allows the MIC2208 to be stable with a wide range of inductor and capacitor values.

TYPE II compensation

Type II compensation can be expressed as pole-zero-pole. In our case, a dominant pole (R1 and C3) followed by a zero (C3 and R4), allowing the final pole to be provided by the output inductor and output capacitor (L and COUT). This mode of compensation works well when using higher ESR output capacitors, such as tantalum and electrolytic dielectrics. The ESR of the capacitor, along with the output capacitance provides a zero (COUT and ESR) that negates one of the two poles created by the inductor-output capacitor filter. This allows the gain to cross the 0dB point with a -1 slope (-20dB/decade).

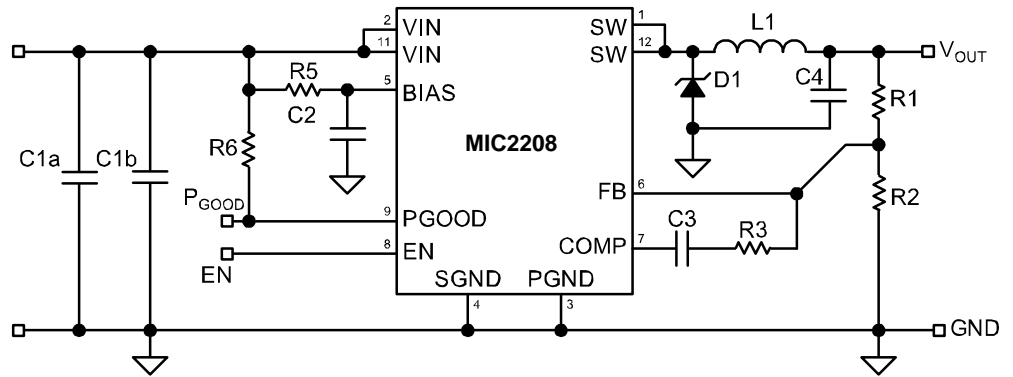
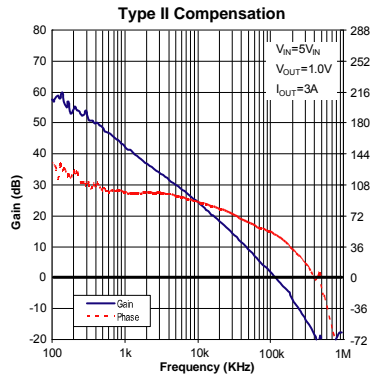

Bill of Materials

Item	Part Number	Manufacturer	Description	Qty.
C1a, C1b	C2012JB0J106K	TDK ⁽¹⁾	10µF Ceramic Capacitor X5R 0805 6.3V	2
	GRM219R60J106KE19	Murata ⁽²⁾		
	08056D106MAT	AVX ⁽³⁾		
C2	0402ZD104MAT	AVX ⁽³⁾	0.1µF Ceramic Capacitor X5R 0402 10V	1
C3	0402ZD100MAT	AVX ⁽³⁾	100pF Ceramic Capacitor X5R 0402 10V	1
C4	TPME477M010R0030	AVX ⁽³⁾	470µF Tantalum Capacitor 10V	1
D1	SSA33L	Vishay Semi ⁽⁴⁾	3A Schottky 30V SMA	1
L1	RLF7030-1R0N6R4	TDK ⁽¹⁾	1µH Inductor 8.8mΩ 7.1mm(L) x 6.8mm (W)x 3.2mm(H)	1
	744 778 9001	Würth Elektronik ⁽⁵⁾	1µH Inductor 12mΩ 7.3mm(L)x7.3mm(W)x3.2mm(H)	
	IHLP2525AH-01 1	Vishay Dale ⁽⁴⁾	1µH Inductor 17.5mΩ (L)6.47mmx(W)6.86mmx(H) 1.8mm	
R1	CRCW04023012F	Vishay Dale ⁽⁴⁾	30.1KΩ 1% 0402 Resistor	1
R2	CRCW04022002F	Vishay Dale ⁽⁴⁾	20 kΩ 1% 0402 For 2.5V _{OUT}	1
	CRCW04023742F	Vishay Dale ⁽⁴⁾	37.4 kΩ 1% 0402 For 1.8 V _{OUT}	
	CRCW04026042F	Vishay Dale ⁽⁴⁾	60.4 kΩ 1% 0402 For 1.5 V _{OUT}	
	CRCW04021503F	Vishay Dale ⁽⁴⁾	150 kΩ 1% 0402 For 1.2 V _{OUT}	
		Vishay Dale ⁽⁴⁾	Open For 1.0 V _{OUT}	
R4	CRCW04024993F	Vishay Dale ⁽⁴⁾	499KΩ 1% 0402 Resistor	1
R5	CRCW040210R0F	Vishay Dale ⁽⁴⁾	10Ω 1% 0402 Resistor	1
R6	CRCW04021002F	Vishay Dale ⁽⁴⁾	10KΩ 1% 0402 Resistor	1
U1	MIC2208BML	Micrel, Inc. ⁽⁶⁾	1MHz 3A Buck Regulator	1

Notes:

1. TDK: www.tdk.com
2. Murata: www.murata.com
3. AVX: www.avx.com
4. Vishay: www.vishay.com
5. Würth Elektronik Midcom, Inc.: www.midcom-inc.com
6. Micrel, Inc.: www.micrel.com

TYPE III compensation

Type III in our case, is a dominant pole (C3 and R1) followed by a zero (C3 and R4) and an additional zero (C5 and R4), allowing the final pole to be provided by the output inductor and output capacitor. This mode of compensation is required when using low ESR output capacitors, such as ceramic capacitors. The additional zero offsets the double pole created by the inductor/output capacitor filter.

Type III Open Loop Gain Response

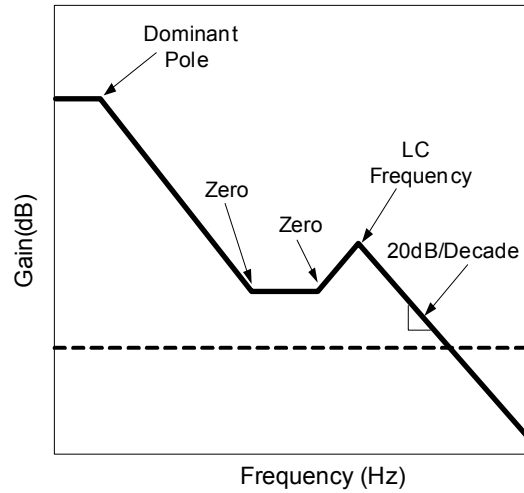

Type III Compensation

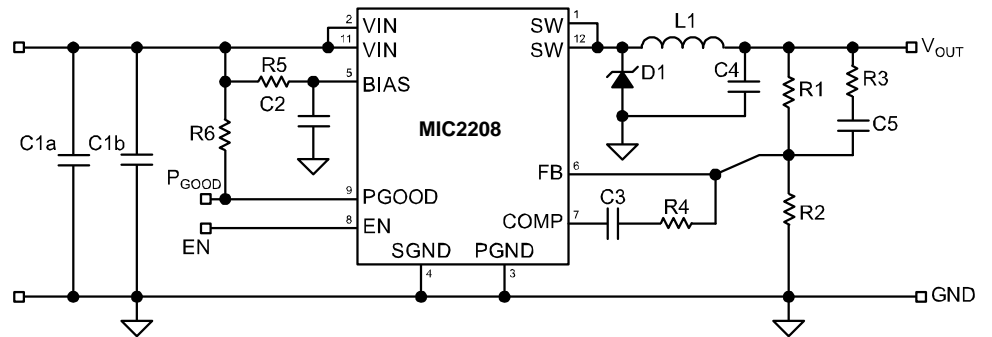
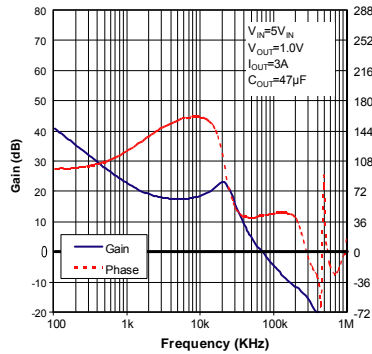

Bill of Materials

Item	Part Number	Manufacturer	Description	Qty.
C1a, C1b	C2012JB0J106K	TDK ⁽¹⁾	10µF Ceramic Capacitor X5R 0805 6.3V	2
	GRM219R60J106KE19	Murata ⁽²⁾		
	08056D106MAT	AVX ⁽³⁾		
C2	0402ZD104MAT	AVX ⁽³⁾	0.1µF Ceramic Capacitor X5R 0402 10V	1
C3	0402ZD103MAT	AVX ⁽³⁾	1nF Ceramic Capacitor X5R 0402 10V	1
C4	C3216X5R0J476K	TDK ⁽¹⁾	47µF Ceramic Capacitor X5R 1206 6.3V	1
	GRM32ER60J476ME20	Murata ⁽²⁾		
	12106D476MAT2A	AVX ⁽³⁾		
C5	VJ0402A330KXAA	Vishay VT ⁽⁴⁾	33pF Ceramic Capacitor 0402	1
D1	SSA33L	Vishay Semi ⁽⁴⁾	3A Schottky 30V SMA	1
L1	RLF7030-1R0N6R4	TDK ⁽¹⁾	1µH Inductor 8.8mΩ 7.1mm(L) x 6.8mm (W)x 3.2mm(H)	1
	744 778 9001	Würth Elektronik ⁽⁵⁾	1µH Inductor 12mΩ 7.3mm(L)x7.3mm(W)x3.2mm(H)	
	IHLP2525AH-01 1	Vishay Dale ⁽⁴⁾	1µH Inductor 17.5mΩ (L)6.47mmx(W)6.86mmx(H) 1.8mm	

R1	CRCW04024992F	Vishay Dale ⁽⁴⁾	49.9KΩ 1% 0402 Resistor	1
R2	CRCW04023322F	Vishay Dale ⁽⁴⁾	33.3 kΩ 1% 0402 For 2.5V _{OUT}	1
	CRCW04026192F	Vishay Dale ⁽⁴⁾	61.9 kΩ 1% 0402 For 1.8 V _{OUT}	
	CRCW04021003F	Vishay Dale ⁽⁴⁾	100 kΩ 1% 0402 For 1.5 V _{OUT}	
	CRCW04022493F	Vishay Dale ⁽⁴⁾	249 kΩ 1% 0402 For 1.2 V _{OUT}	
		Vishay Dale ⁽⁴⁾	Open For 1.0 V _{OUT}	
R3	CRCW04024991F	Vishay Dale ⁽⁴⁾	499KΩ 1% 0402 Resistor	
R4	CRCW04024991F	Vishay Dale ⁽⁴⁾	90.9KΩ 1% 0402 Resistor	1
R5	CRCW040210R0F	Vishay Dale ⁽⁴⁾	10Ω 1% 0402 Resistor	1
R6	CRCW04021002F	Vishay Dale ⁽⁴⁾	10KΩ 1% 0402 Resistor	1
U1	MIC2208BML	Micrel, Inc. ⁽⁶⁾	1MHz 3A Buck Regulator	1

Notes:

1. TDK: www.tdk.com
2. Murata: www.murata.com
3. AVX: www.avx.com
4. Vishay: www.vishay.com
5. Würth Elektronik Midcom, Inc.: www.midcom-inc.com
6. Micrel, Inc.: www.micrel.com

Loop Stability and Bode Analysis

Bode analysis is an excellent way to measure small signal stability and loop response in power supply designs. Bode analysis monitors gain and phase of a control loop. This is done by breaking the feedback loop and injecting a signal into the feedback node and comparing the injected signal to the output signal of the control loop. This will require a network analyzer to sweep the frequency and compare the injected signal to the output signal. The most common method of injection is the use of transformer. Figure 7 demonstrates how a transformer is used to inject a signal into the feedback network.

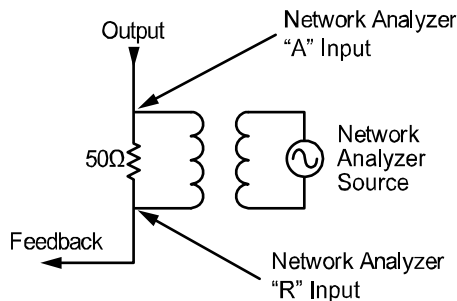

Figure 7. Transformer Injection

A 50Ω resistor allows impedance matching from the network analyzer source. This method allows the DC loop to maintain regulation and allow the network analyzer to insert an AC signal on top of the DC voltage.

The network analyzer will then sweep the source while monitoring A and R for an A/R measurement. While this is the most common method for measuring the gain and phase of a power supply, it does have significant limitations. First, to measure low frequency gain and phase, the transformer needs to be high in inductance. This makes frequencies <100Hz require an extremely large and expensive transformer. Conversely, it must be able to inject high frequencies. Transformers with these wide frequency ranges generally need to be custom made and are extremely expensive (usually in the tune of several hundred dollars!). By using an op-amp, cost and frequency limitations used by an injection transformer are completely eliminated. Figure 8 demonstrates using an op-amp in a summing amplifier configuration for signal injection.

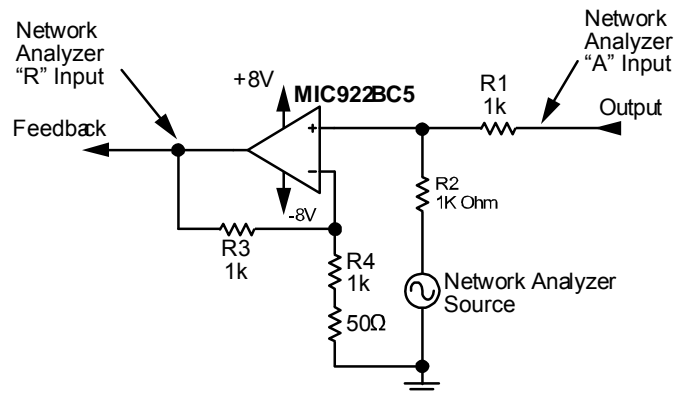

Figure 8. Op Amp Injection

R1 and R2 reduce the DC voltage from the output to the non-inverting input by half. The network analyzer is generally a 50Ω source. R1 and R2 also divide the AC signal sourced by the network analyzer by half. These two signals are “summed” together at half of their original input. The output is then gained up by 2 by R3 and R4 (the 50Ω is to balance the network analyzer’s source impedance) and sent to the feedback signal. This essentially breaks the loop and injects the AC signal on top of the DC output voltage and sends it to the feedback. By monitoring the feedback “R” and output “A”, gain and phase are measured. This method has no minimum frequency. Ensure that the bandwidth of the op-amp being used is much greater than the expected bandwidth of the power supplies control loop. An op-amp with >100MHz bandwidth is more than sufficient for most power supplies (which includes both linear and switching) and are more common and significantly cheaper than the injection transformers previously mentioned. The one disadvantage to using the op-amp injection method, that the supply voltages need to be below the maximum operating voltage of the op-amp. Also, the maximum output voltage for driving 50Ω inputs using the MIC922 is 3V. For measuring higher output voltages, a 1MΩ input impedance is required for the A and R channels. Remember to always measure the output voltage with an oscilloscope to ensure the measurement is working properly. You should see a single sweeping sinusoidal waveform without distortion on the output. If there is distortion of the sinusoid, reduce the amplitude of the source signal. You could be overdriving the feedback causing a large signal response.

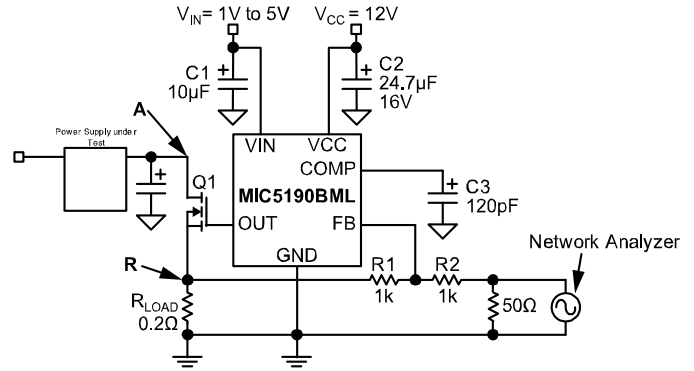

Figure 9. Output Impedance Measurement

By setting up a network analyzer to sweep the feedback current, while monitoring the output of the voltage regulator and the voltage across the load resistance, output impedance is easily obtainable. To keep the current from being too high, a DC offset needs to be applied to the network analyzer’s source signal. This can be done with an external supply and 50Ω resistor. Make sure that the currents are verified with an oscilloscope first, to ensure the integrity of the signal measurement. It is always a good idea to monitor the A and R measurements with a scope while you are sweeping it. To convert the network analyzer data from dBm to something more useful (such as peak-to-peak voltage and current in our case):

$$\Delta V = \frac{\sqrt{10 \frac{\text{dBm}}{10} \times 1\text{mW} \times 50\Omega \times 2}}{0.707}$$

and peak to peak current:

$$\Delta I = \frac{\sqrt{10 \frac{\text{dBm}}{10} \times 1\text{mW} \times 50\Omega \times 2}}{0.707 \times R_{\text{LOAD}}}$$

The following graph shows output impedance vs. frequency at 2A load current sweeping the AC current from 10Hz to 10MHz, at 1A peak to peak amplitude.

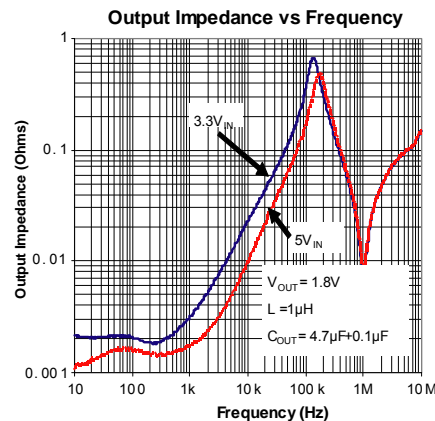

Output Impedance and Transient response

Output impedance, simply stated, is the amount of output voltage deviation vs. the load current deviation. The lower the output impedance, the better.

$$Z_{\text{OUT}} = \frac{\Delta V_{\text{OUT}}}{\Delta I_{\text{OUT}}}$$

Output impedance for a buck regulator is the parallel impedance of the output capacitor and the MOSFET and inductor divided by the gain:

$$Z_{\text{TOTAL}} = \frac{R_{\text{DS(on)}} + \text{DCR} + X_L}{\text{GAIN}} \parallel X_{\text{COUT}}$$

To measure output impedance vs. frequency, the load current must be swept across the frequencies measured, while the output voltage is monitored. Figure 9 shows a test set-up to measure output impedance from 10Hz to 1MHz using the MIC5190 high speed controller.

From this graph, you can see the effects of bandwidth and output capacitance. For frequencies <100KHz, the output impedance is dominated by the gain and inductance. For frequencies >100KHz, the output impedance is dominated by the capacitance. A good approximation for transient response can be calculated from determining the frequency of the load step in amps per second:

$$f = \frac{A/\text{sec}}{2\pi}$$

Then, determine the output impedance by looking at the output impedance vs. frequency graph. Then calculating the voltage deviation times the load step:

$$\Delta V_{\text{OUT}} = \Delta I_{\text{OUT}} \times Z_{\text{OUT}}$$

The output impedance graph shows the relationship between supply voltage and output impedance. This is caused by the lower $R_{\text{DS(ON)}}$ of the high side MOSFET and the increase in gain with increased supply voltages. This explains why higher supply voltages have better transient response.

$$\downarrow Z_{\text{TOTAL}} = \frac{\downarrow R_{\text{DS(ON)}} + \text{DCR} + X_L}{\uparrow \text{GAIN}} \parallel X_{\text{COUT}}$$

Ripple measurements

To properly measure ripple on either input or output of a switching regulator, a proper ring in tip measurement is required. Standard oscilloscope probes come with a grounding clip, or a long wire with an alligator clip. Unfortunately, for high frequency measurements, this ground clip can pick-up high frequency noise and erroneously inject it into the measured output ripple.

The standard evaluation board accommodates a home made version by providing probe points for both the input and output supplies and their respective grounds. This requires the removing of the oscilloscope probe sheath and ground clip from a standard oscilloscope probe and wrapping a non-shielded bus wire around the oscilloscope probe. If there does not happen to be any non shielded bus wire immediately available, the leads from axial resistors will work. By maintaining the shortest possible ground lengths on the oscilloscope probe, true ripple measurements can be obtained

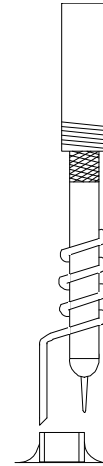

Package Information

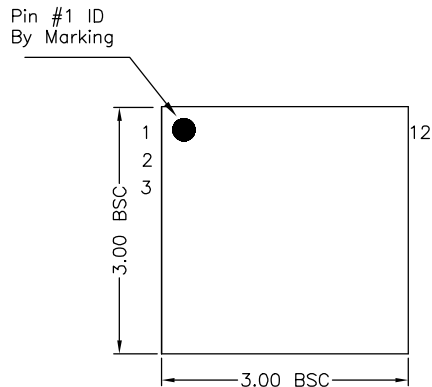

TOP VIEW

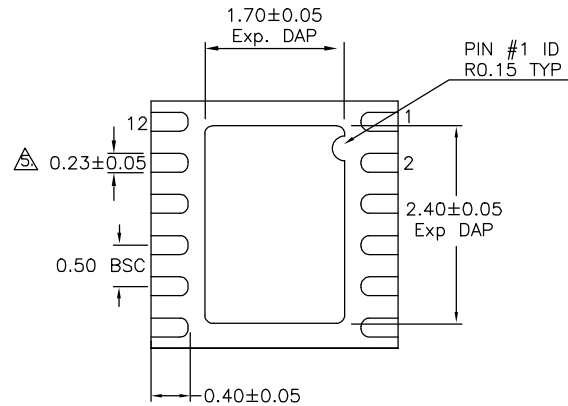

BOTTOM VIEW

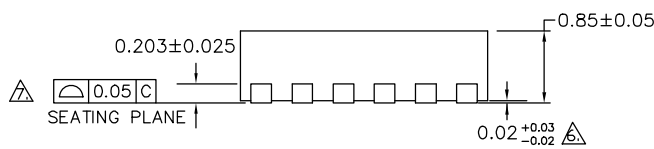

SIDE VIEW

NOTE:

1. ALL DIMENSIONS ARE IN MILLIMETERS.
 2. MAX. PACKAGE WARPAGE IS 0.05 mm.
 3. MAXIMUM ALLOWABLE BURRS IS 0.076 mm IN ALL DIRECTIONS.
 4. PIN #1 ID ON TOP WILL BE LASER/INK MARKED.
- △ DIMENSION APPLIES TO METALIZED TERMINAL AND IS MEASURED BETWEEN 0.20 AND 0.25 mm FROM TERMINAL TIP.
- △ APPLIED ONLY FOR TERMINALS.
- △ APPLIED FOR EXPOSED PAD AND TERMINALS.

12-Pin MLF[®] (ML)

MICREL, INC. 2180 FORTUNE DRIVE SAN JOSE, CA 95131 USA
 TEL +1 (408) 944-0800 FAX +1 (408) 474-1000 WEB <http://www.micrel.com>

The information furnished by Micrel in this data sheet is believed to be accurate and reliable. However, no responsibility is assumed by Micrel for its use. Micrel reserves the right to change circuitry and specifications at any time without notification to the customer.

Micrel Products are not designed or authorized for use as components in life support appliances, devices or systems where malfunction of a product can reasonably be expected to result in personal injury. Life support devices or systems are devices or systems that (a) are intended for surgical implant into the body or (b) support or sustain life, and whose failure to perform can be reasonably expected to result in a significant injury to the user. A Purchaser's use or sale of Micrel Products for use in life support appliances, devices or systems is a Purchaser's own risk and Purchaser agrees to fully indemnify Micrel for any damages resulting from such use or sale.

© 2005 Micrel, Incorporated.

Looking for pricing, stock, or lifecycle information?

Click below to explore more details on WIN SOURCE:

- ⊖ [View MIC2208YML-EV on WIN SOURCE](#)
- ⊖ [Microchip Technology Information](#)

Optimize Your Supply Chain with WIN SOURCE Solutions

- ✓ Global Sourcing Solution
- ✓ Obsolete Management
- ✓ Cost Control Management
- ✓ Shortage Management
- ✓ Alternative Solution
- ✓ Excess Inventory Management