



**THE DATASHEET OF
MCP73833T-FCI/UN**



ADC0831-N/ADC0832-N/ADC0834-N/ADC0838-N 8-Bit Serial I/O A/D Converters with Multiplexer Options

 Check for Samples: [ADC0831-N](#), [ADC0832-N](#), [ADC0834-N](#), [ADC0838-N](#)

FEATURES

- TI MICROWIRE Compatible—Direct Interface to COPS Family Processors
- Easy Interface to All Microprocessors, or Operates “Stand-Alone”
- Operates Ratiometrically or with 5 V_{DC} Voltage Reference
- No Zero or Full-Scale Adjust Required
- 2-, 4- or 8-Channel Multiplexer Options with Address Logic
- Shunt Regulator Allows Operation with High Voltage Supplies
- 0V to 5V Input Range with Single 5V Power Supply
- Remote Operation with Serial Digital Data Link
- TTL/MOS Input/Output Compatible
- 0.3 in. Standard Width, 8-, 14- or 20-Pin PDIP Package
- 20 Pin PLCC Package (ADC0838-N Only)
- SOIC Package

KEY SPECIFICATIONS

- Resolution: 8 Bits
- Total Unadjusted Error: $\pm\frac{1}{2}$ LSB and ± 1 LSB
- Single Supply: 5 V_{DC}
- Low Power: 15 mW
- Conversion Time: 32 μ s

DESCRIPTION

The ADC0831 series are 8-bit successive approximation A/D converters with a serial I/O and configurable input multiplexers with up to 8 channels. The serial I/O is configured to comply with the TI MICROWIRE serial data exchange standard for easy interface to the COPS family of processors, and can interface with standard shift registers or μ Ps.

The 2-, 4- or 8-channel multiplexers are software configured for single-ended or differential inputs as well as channel assignment.

The differential analog voltage input allows increasing the common-mode rejection and offsetting the analog zero input voltage value. In addition, the voltage reference input can be adjusted to allow encoding any smaller analog voltage span to the full 8 bits of resolution.

Typical Application

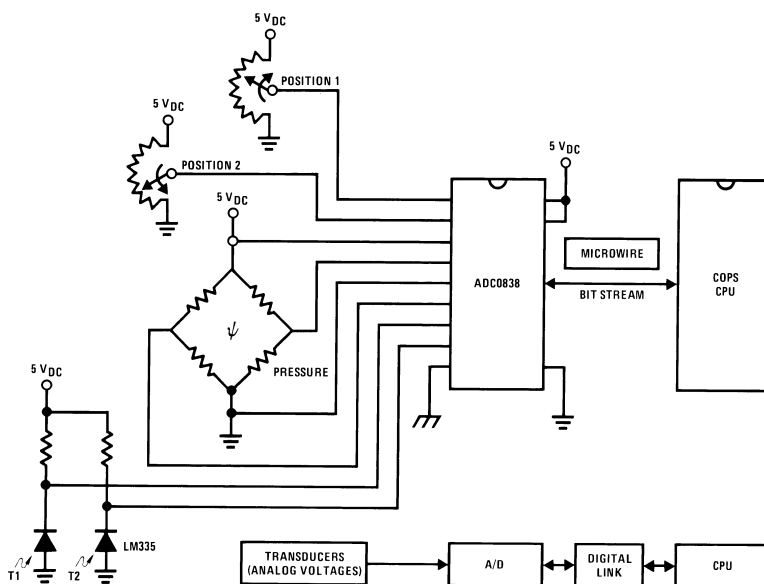

Please be aware that an important notice concerning availability, standard warranty, and use in critical applications of Texas Instruments semiconductor products and disclaimers thereto appears at the end of this data sheet.

All trademarks are the property of their respective owners.

Connection Diagrams

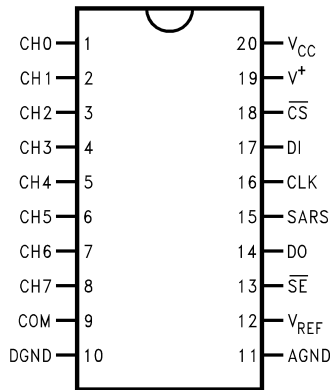

Figure 1. ADC0838-N 8-Channel Mux SOIC/PDIP Package (DW or NFH) Top View

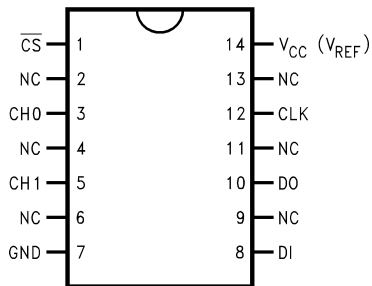
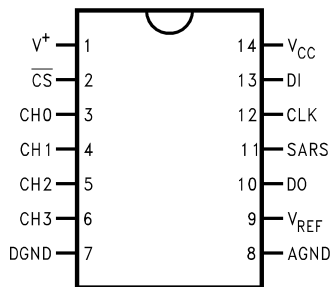

Figure 2. ADC0832-N 2-Channel MUX SOIC Package (NPA) Top View



COM internally connected to A GND
Top View

Figure 3. ADC0834-N 4-Channel MUX SOIC/PDIP (NPA or NFF) Top View

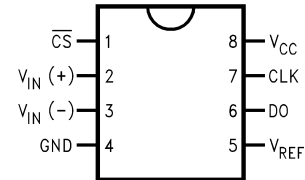
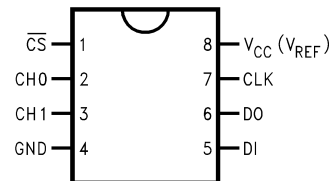

Figure 4. ADC0831-N Single Differential Input PDIP Package (P) Top View



COM internally connected to GND.
VREF internally connected to VCC.
Top View

Figure 5. ADC0832-N 2-Channel MUX PDIP Package (P) Top View

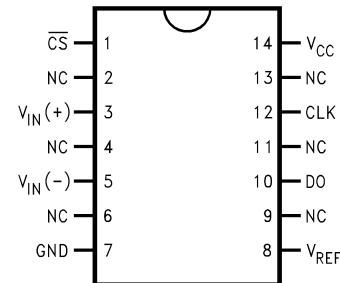

Figure 6. ADC0831-N Single Differential Input SOIC Package (NPA) Top View

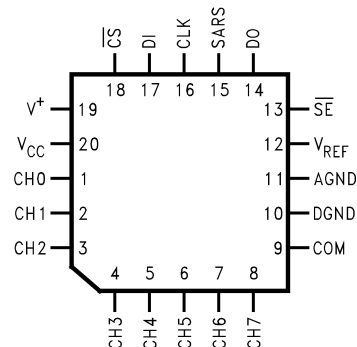

Figure 7. ADC0838-N 8-Channel MUX PLCC Package (FN)



These devices have limited built-in ESD protection. The leads should be shorted together or the device placed in conductive foam during storage or handling to prevent electrostatic damage to the MOS gates.

Absolute Maximum Ratings⁽¹⁾⁽²⁾⁽³⁾

Current into V ⁺ ⁽⁴⁾		15 mA
Supply Voltage, V _{CC} ⁽⁴⁾		6.5V
Voltage	Logic Inputs	-0.3V to V _{CC} + 0.3V
	Analog Inputs	-0.3V to V _{CC} + 0.3V
Input Current per	Pin ⁽⁵⁾	±5 mA
	Package	±20 mA
Storage Temperature		-65°C to +150°C
Package Dissipation	at T _A = 25°C (Board Mount)	0.8W
Lead Temperature (Soldering 10 sec.)	PDIP Package	260°C
PLCC Package	Vapor Phase (60 sec.)	215°C
	Infrared (15 sec.)	220°C
ESD Susceptibility ⁽⁶⁾		2000V

- (1) All voltages are measured with respect to the ground plugs.
- (2) Absolute Maximum Ratings indicate limits beyond which damage to the device may occur. DC and AC electrical specifications do not apply when operating the device beyond its specified operating conditions.
- (3) If Military/Aerospace specified devices are required, please contact the Texas Instruments Sales Office/Distributors for availability and specifications.
- (4) Internal zener diodes (6.3 to 8.5V) are connected from V⁺ to GND and V_{CC} to GND. The zener at V⁺ can operate as a shunt regulator and is connected to V_{CC} via a conventional diode. Since the zener voltage equals the A/D's breakdown voltage, the diode insures that V_{CC} will be below breakdown when the device is powered from V⁺. Functionality is therefore ensured for V⁺ operation even though the resultant voltage at V_{CC} may exceed the specified Absolute Max of 6.5V. It is recommended that a resistor be used to limit the max current into V⁺. (See [Figure 24](#) in Functional Description)
- (5) When the input voltage (V_{IN}) at any pin exceeds the power supply rails (V_{IN} < V⁻ or V_{IN} > V⁺) the absolute value of current at that pin should be limited to 5 mA or less. The 20 mA package input current limits the number of pins that can exceed the power supply boundaries with a 5 mA current limit to four.
- (6) Human body model, 100 pF discharged through a 1.5 kΩ resistor.

Operating Ratings⁽¹⁾⁽²⁾

Supply Voltage, V _{CC}		4.5 V _{DC} to 6.3 V _{DC}
Temperature Range (T _{MIN} ≤ T _A ≤ T _{MAX})	ADC0832/8CIWM ADC0834BCN, ADC0838BCV, ADC0831/2/4/8CCN, ADC0838CCV	-40°C to +85°C
	ADC0831/2/4/8CCWM	0°C to +70°C

- (1) Absolute Maximum Ratings indicate limits beyond which damage to the device may occur. DC and AC electrical specifications do not apply when operating the device beyond its specified operating conditions.
- (2) All voltages are measured with respect to the ground plugs.

Converter and Multiplexer Electrical Characteristics

The following specifications apply for $V_{CC} = V+ = V_{REF} = 5V$, $V_{REF} \leq V_{CC} + 0.1V$, $T_A = T_j = 25^\circ C$, and $f_{CLK} = 250\text{ kHz}$ unless otherwise specified. **Boldface limits apply from T_{MIN} to T_{MAX} .**

Parameter	Conditions	CIWM Devices			BCV, CCV, CCWM, BCN and CCN Devices			Units
		Typ ⁽¹⁾	Tested Limit ⁽²⁾	Design Limit ⁽³⁾	Typ ⁽¹⁾	Tested Limit ⁽²⁾	Design Limit ⁽³⁾	
CONVERTER AND MULTIPLEXER CHARACTERISTICS								
Total Unadjusted Error	ADC0838BCV	$V_{REF} = 5.00\text{ V}^{(4)}$				$\pm\frac{1}{2}$	$\pm\frac{1}{2}$	LSB (Max)
	ADC0834BCN					$\pm\frac{1}{2}$	$\pm\frac{1}{2}$	
	ADC0838CCV					± 1	± 1	
	ADC0831/2/4/8CCN					± 1	± 1	
	ADC0831/2/4/8CCWM					± 1	± 1	
	ADC0832/8CIWM			± 1				
Minimum Reference Input Resistance ⁽⁵⁾		3.5	1.3		3.5	1.3	1.3	k Ω
Maximum Reference Input Resistance ⁽⁵⁾		3.5	5.9		3.5	5.4	5.9	k Ω
Maximum Common-Mode Input Range ⁽⁶⁾			$V_{CC} + 0.05$			$V_{CC} + 0.05$	$V_{CC} + 0.05$	V
Minimum Common-Mode Input Range ⁽⁶⁾			GND - 0.05			GND - 0.05	GND - 0.05	V
DC Common-Mode Error		$\pm 1/16$	$\pm\frac{1}{4}$		$\pm 1/16$	$\pm\frac{1}{4}$	$\pm\frac{1}{4}$	LSB
Change in zero error from $V_{CC}=5V$ to internal zener operation ⁽⁷⁾	15 mA into V+, $V_{CC} = \text{N.C.}$, $V_{REF} = 5V$		1			1	1	LSB
V_Z , internal diode breakdown (at V+) ⁽⁷⁾	MIN	15 mA into V+	6.3			6.3	6.3	V
	MAX		8.5			8.5	8.5	
Power Supply Sensitivity	$V_{CC} = 5V \pm 5\%$	$\pm 1/16$	$\pm\frac{1}{4}$	$\pm\frac{1}{4}$	$\pm 1/16$	$\pm\frac{1}{4}$	$\pm\frac{1}{4}$	LSB
I_{OFF} , Off Channel Leakage Current ⁽⁸⁾	On Channel = 5V		-0.2			-0.2	-1	μA
	Off Channel = 0V		-1					
	On Channel = 0V		+0.2			+0.2	+1	μA
	Off Channel = 5V		+1					
I_{ON} , On Channel Leakage Current ⁽⁸⁾	On Channel = 0V		-0.2			-0.2	-1	μA
	Off Channel = 5V		-1					
	On Channel = 5V		+0.2			+0.2	+1	μA
	Off Channel = 0V		+1					

- (1) Typicals are at 25°C and represent most likely parametric norm.
- (2) Tested limits are ensured to TI's AOQL (Average Outgoing Quality Level).
- (3) Ensured but not 100% production tested. These limits are not used to calculate outgoing quality levels.
- (4) Total unadjusted error includes offset, full-scale, linearity, and multiplexer errors.
- (5) Cannot be tested for ADC0832-N.
- (6) For $V_{IN(-)} \geq V_{IN(+)}$ the digital output code will be 0000 0000. Two on-chip diodes are tied to each analog input (see [Functional Block Diagram](#)) which will forward conduct for analog input voltages one diode drop below ground or one diode drop greater than the V_{CC} supply. Be careful, during testing at low V_{CC} levels (4.5V), as high level analog inputs (5V) can cause this input diode to conduct—especially at elevated temperatures, and cause errors for analog inputs near full-scale. The spec allows 50 mV forward bias of either diode. This means that as long as the analog V_{IN} or V_{REF} does not exceed the supply voltage by more than 50 mV, the output code will be correct. To achieve an absolute 0 V_{DC} to 5 V_{DC} input voltage range will therefore require a minimum supply voltage of 4.950 V_{DC} over temperature variations, initial tolerance and loading.
- (7) Internal zener diodes (6.3 to 8.5V) are connected from V+ to GND and V_{CC} to GND. The zener at V+ can operate as a shunt regulator and is connected to V_{CC} via a conventional diode. Since the zener voltage equals the A/D's breakdown voltage, the diode insures that V_{CC} will be below breakdown when the device is powered from V+. Functionality is therefore ensured for V+ operation even though the resultant voltage at V_{CC} may exceed the specified Absolute Max of 6.5V. It is recommended that a resistor be used to limit the max current into V+. (See [Figure 24](#) in Functional Description)
- (8) Leakage current is measured with the clock not switching.

Converter and Multiplexer Electrical Characteristics (continued)

The following specifications apply for $V_{CC} = V_+ = V_{REF} = 5V$, $V_{REF} \leq V_{CC} + 0.1V$, $T_A = T_j = 25^\circ C$, and $f_{CLK} = 250$ kHz unless otherwise specified. **Boldface limits apply from T_{MIN} to T_{MAX} .**

Parameter	Conditions	CIWM Devices			BCV, CCV, CCWM, BCN and CCN Devices			Units	
		Typ ⁽¹⁾	Tested Limit ⁽²⁾	Design Limit ⁽³⁾	Typ ⁽¹⁾	Tested Limit ⁽²⁾	Design Limit ⁽³⁾		
DIGITAL AND DC CHARACTERISTICS									
$V_{IN(1)}$, Logical "1" Input Voltage (Min)	$V_{CC} = 5.25V$		2.0			2.0	2.0	V	
$V_{IN(0)}$, Logical "0" Input Voltage (Max)	$V_{CC} = 4.75V$		0.8			0.8	0.8	V	
$I_{IN(1)}$, Logical "1" Input Current (Max)	$V_{IN} = 5.0V$	0.005	1		0.005	1	1	μA	
$I_{IN(0)}$, Logical "0" Input Current (Max)	$V_{IN} = 0V$	-0.005	-1		-0.005	-1	-1	μA	
$V_{OUT(1)}$, Logical "1" Output Voltage (Min)	$V_{CC} = 4.75V$ $I_{OUT} = -360 \mu A$ $I_{OUT} = -10 \mu A$		2.4			2.4	2.4	V	
			4.5			4.5	4.5	V	
$V_{OUT(0)}$, Logical "0" Output Voltage (Max)	$V_{CC} = 4.75V$, $I_{OUT} = 1.6$ mA		0.4			0.4	0.4	V	
I_{OUT} , TRI-STATE Output Current (Max)	$V_{OUT} = 0V$ $V_{OUT} = 5V$	-0.1	-3		-0.1	-3	-3	μA	
		0.1	3		0.1	+3	+3	μA	
I_{SOURCE} , Output Source Current (Min)	$V_{OUT} = 0V$	-14	-6.5		-14	-7.5	-6.5	mA	
I_{SINK} , Output Sink Current (Min)	$V_{OUT} = V_{CC}$	16	8.0		16	9.0	8.0	mA	
I_{CC} , Supply Current (Max)	ADC0831-N, ADC0834-N, ADC0838-N		0.9	2.5		0.9	2.5	2.5	mA
		ADC0832-N	Includes Ladder Current	2.3	6.5		2.3	6.5	6.5

AC Characteristics

The following specifications apply for $V_{CC} = 5V$, $t_r = t_f = 20\text{ ns}$ and 25°C unless otherwise specified.

Parameter	Conditions	Typ ⁽¹⁾	Tested Limit ⁽²⁾	Design Limit ⁽³⁾	Limit Units
f_{CLK} , Clock Frequency			10		kHz
	Min			400	kHz
	Max				kHz
t_C , Conversion Time	Not including MUX Addressing Time		8		$1/f_{CLK}$
Clock Duty Cycle ⁽⁴⁾	Min			40	%
	Max			60	%
t_{SET-UP} , \overline{CS} Falling Edge or Data Input Valid to CLK Rising Edge				250	ns
t_{HOLD} , Data Input Valid after CLK Rising Edge				90	ns
t_{pd1} , t_{pd0} —CLK Falling Edge to Output Data Valid ⁽⁵⁾	$C_L=100\text{ pF}$				
	Data MSB First	650		1500	ns
	Data LSB First	250		600	ns
t_{1H} , t_{0H} —Rising Edge of CS to Data Output and SARS Hi-Z	$C_L=10\text{ pF}$, $R_L=10\text{ k}$ (See TRI-STATE Test Circuits and Waveforms)	125		250	ns
	$C_L=100\text{ pf}$, $R_L=2\text{ k}$		500		ns
C_{IN} , Capacitance of Logic Input		5			pF
C_{OUT} , Capacitance of Logic Outputs		5			pF

- (1) Typicals are at 25°C and represent most likely parametric norm.
- (2) Tested limits are ensured to TI's AOQL (Average Outgoing Quality Level).
- (3) Ensured but not 100% production tested. These limits are not used to calculate outgoing quality levels.
- (4) A 40% to 60% clock duty cycle range insures proper operation at all clock frequencies. In the case that an available clock has a duty cycle outside of these limits, the minimum, time the clock is high or the minimum time the clock is low must be at least $1\text{ }\mu\text{s}$. The maximum time the clock can be high is $60\text{ }\mu\text{s}$. The clock can be stopped when low so long as the analog input voltage remains stable.
- (5) Since data, MSB first, is the output of the comparator used in the successive approximation loop, an additional delay is built in (see [ADC0838-N Functional Block Diagram](#)) to allow for comparator response time.

Typical Performance Characteristics

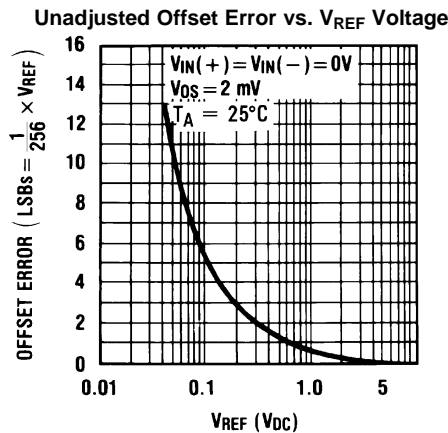

Figure 8.

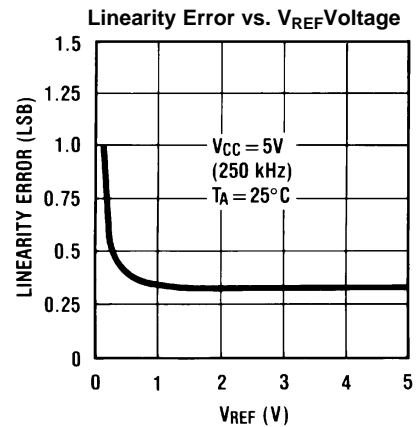

Figure 9.

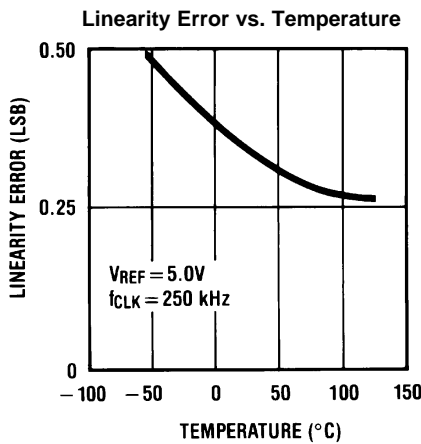

Figure 10.

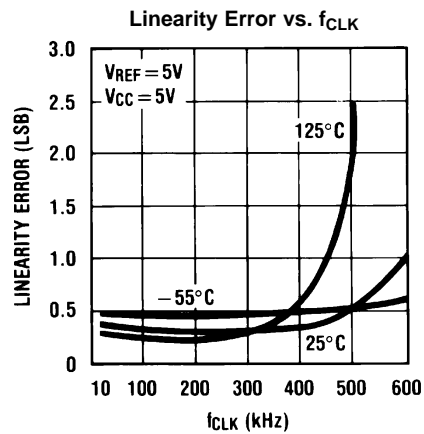
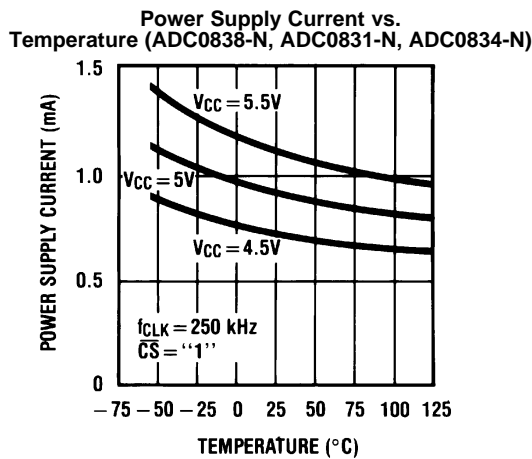

Figure 11.



Note: For ADC0832-N add I_{REF} .

Figure 12.

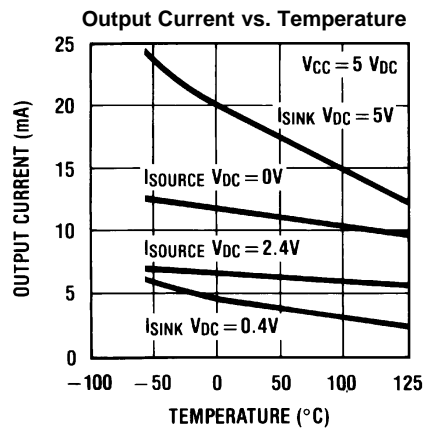

Figure 13.

Typical Performance Characteristics (continued)

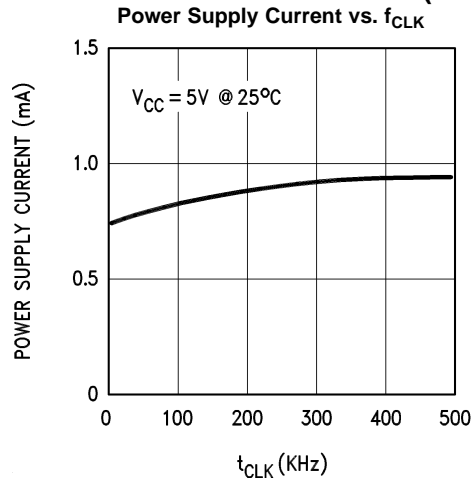
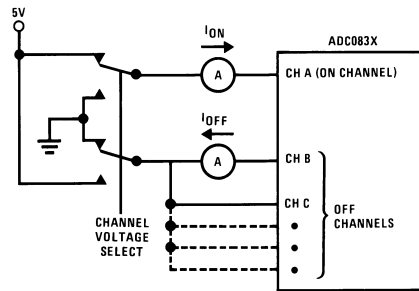
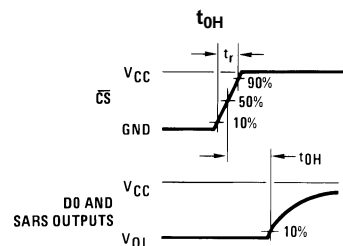
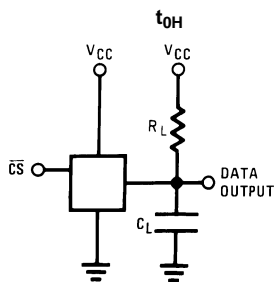
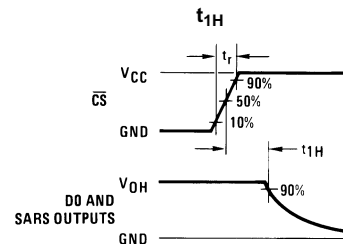
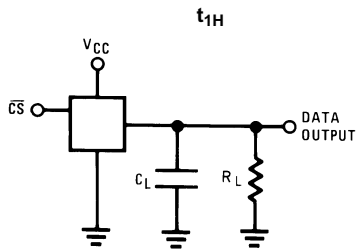

Figure 14.

Leakage Current Test Circuit



TRI-STATE Test Circuits and Waveforms



Timing Diagrams

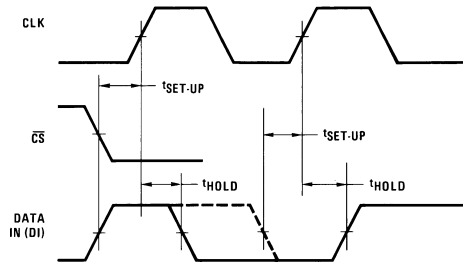

Figure 15. Data Input Timing

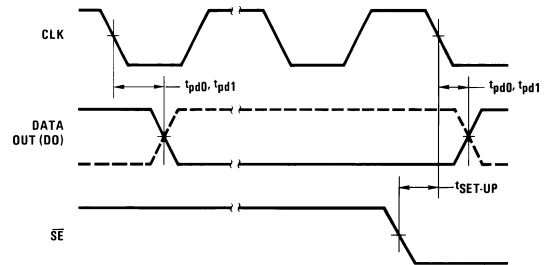

Figure 16. Data Output Timing

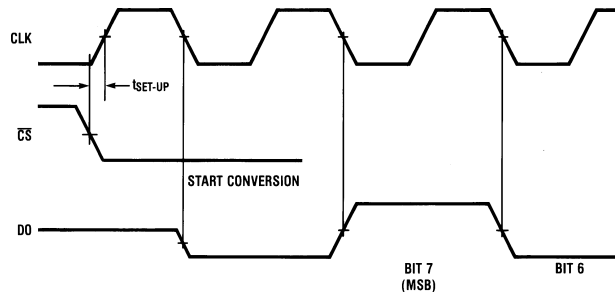
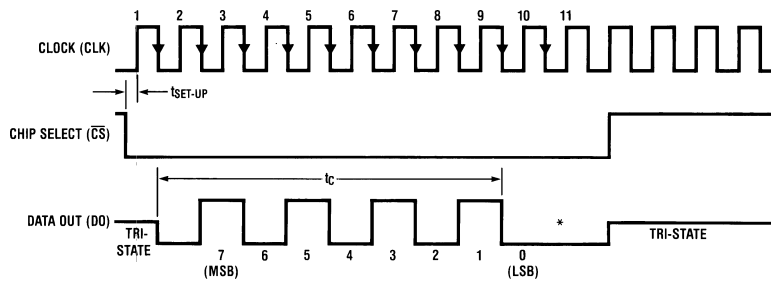

Figure 17. ADC0831-N Start Conversion Timing



*LSB first output not available on ADC0831-N.

Figure 18. ADC0831-N Timing

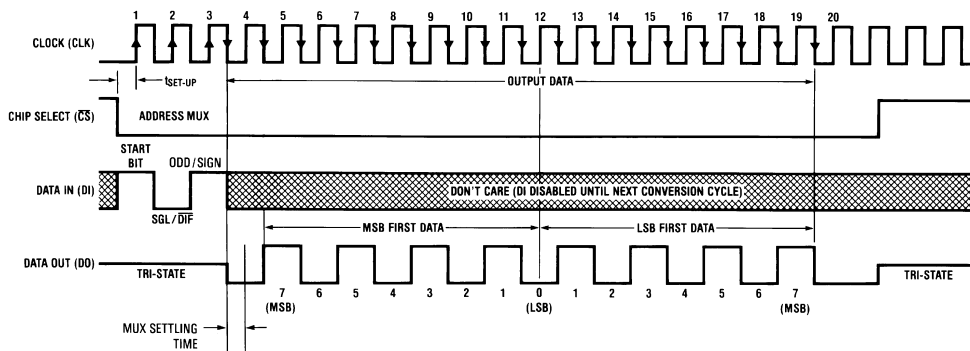

Figure 19. ADC0832-N Timing

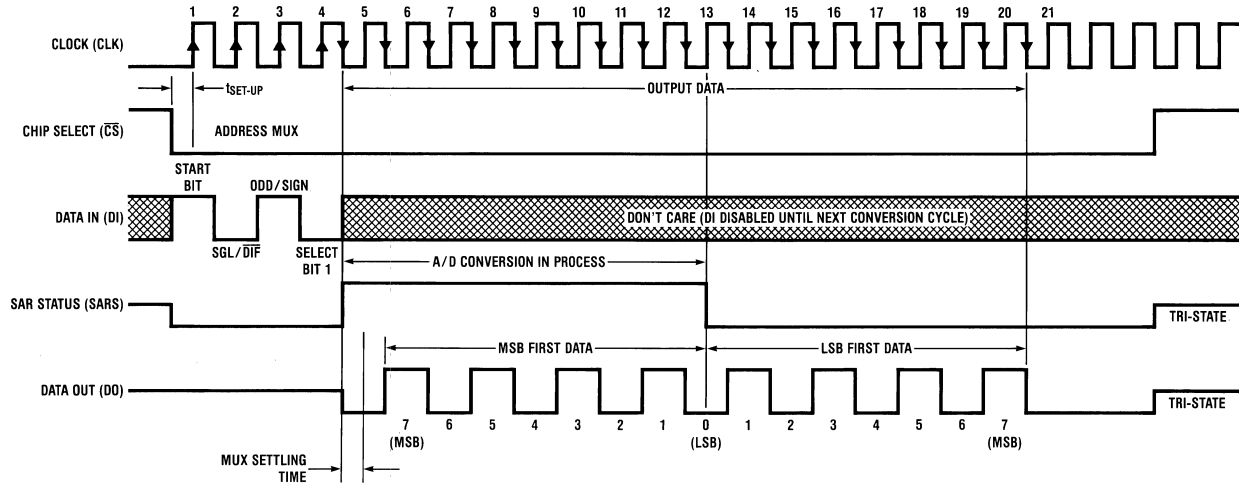
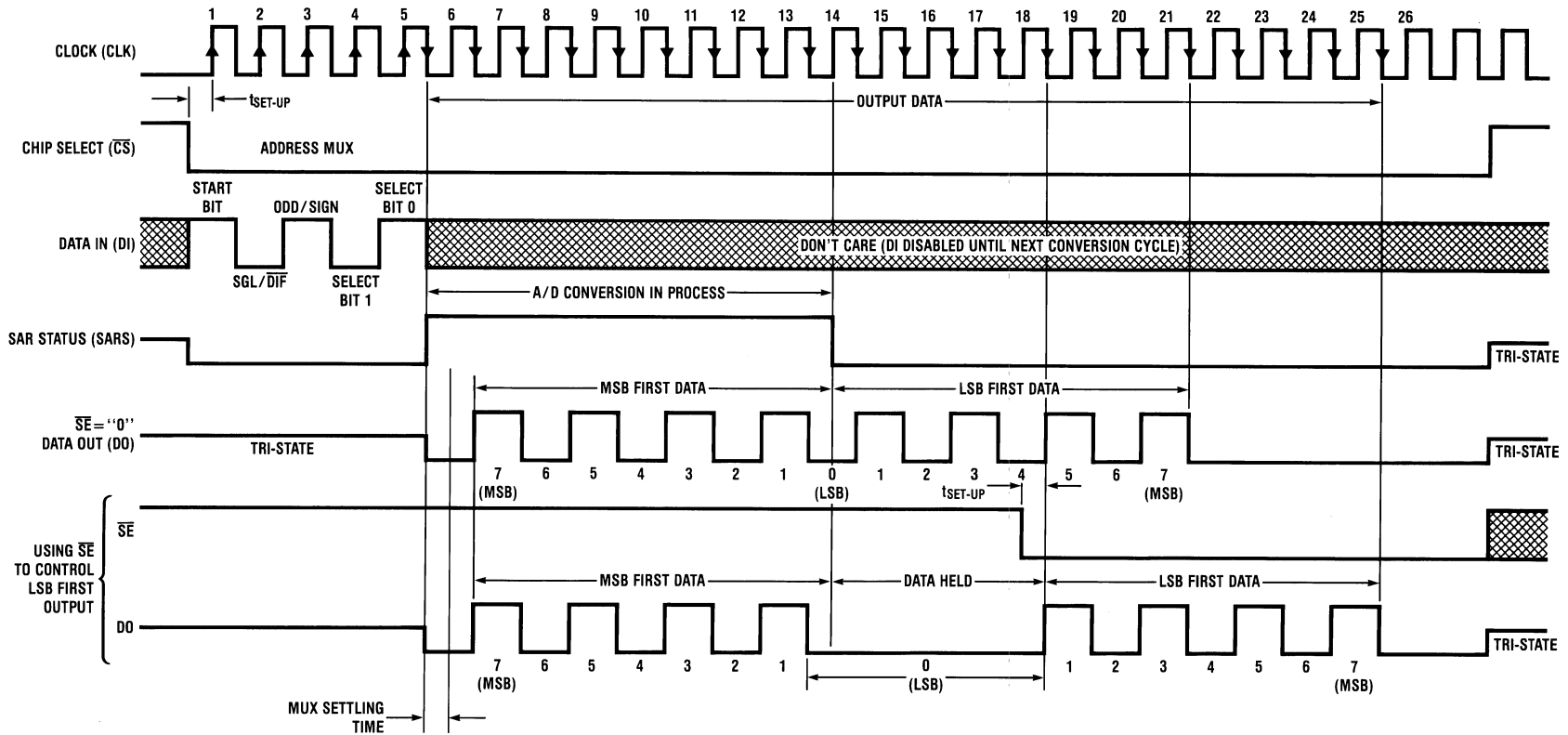

Figure 20. ADC0834-N Timing



*Make sure clock edge #18 clocks in the LSB before \overline{SE} is taken low

Figure 21. ADC0838-N Timing

ADC0838-N Functional Block Diagram

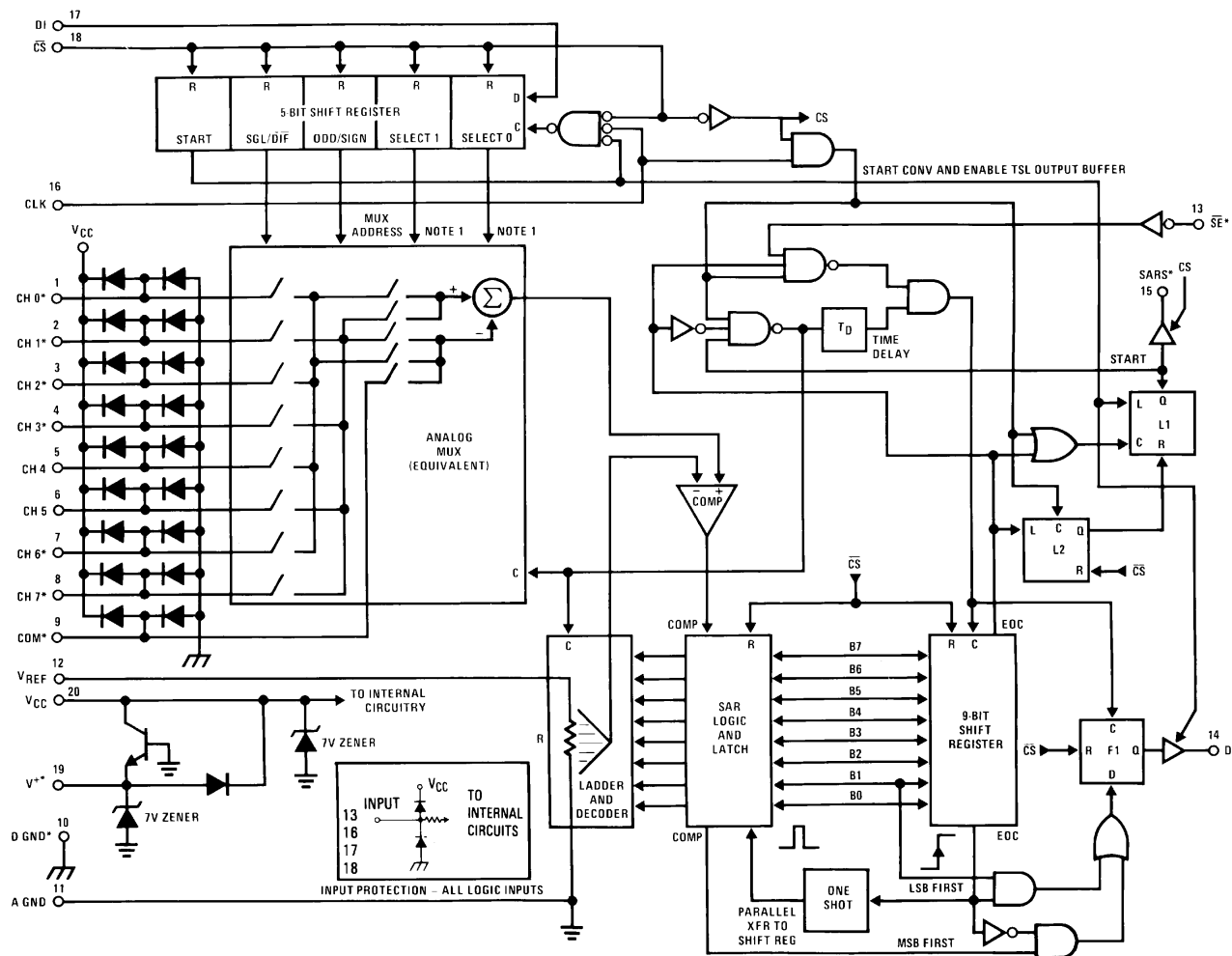

*Some of these functions/pins are not available with other options.

Note 1: For the ADC0834-N, D1 is input directly to the D input of SELECT 1. SELECT 0 is forced to a "1". For the ADC0832-N, DI is input directly to the DI input of ODD/SIGN. SELECT 0 is forced to a "0" and SELECT 1 is forced to a "1".

Functional Description

Multiplexer Addressing

The design of these converters utilizes a sample-data comparator structure which provides for a differential analog input to be converted by a successive approximation routine.

The actual voltage converted is always the difference between an assigned “+” input terminal and a “-” input terminal. The polarity of each input terminal of the pair being converted indicates which line the converter expects to be the most positive. If the assigned “+” input is less than the “-” input the converter responds with an all zeros output code.

A unique input multiplexing scheme has been utilized to provide multiple analog channels with software-configurable single-ended, differential, or a new pseudo-differential option which will convert the difference between the voltage at any analog input and a common terminal. The analog signal conditioning required in transducer-based data acquisition systems is significantly simplified with this type of input flexibility. One converter package can now handle ground referenced inputs and true differential inputs as well as signals with some arbitrary reference voltage.

A particular input configuration is assigned during the MUX addressing sequence, prior to the start of a conversion. The MUX address selects which of the analog inputs are to be enabled and whether this input is single-ended or differential. In the differential case, it also assigns the polarity of the channels. Differential inputs are restricted to adjacent channel pairs. For example channel 0 and channel 1 may be selected as a different pair but channel 0 or 1 cannot act differentially with any other channel. In addition to selecting differential mode the sign may also be selected. Channel 0 may be selected as the positive input and channel 1 as the negative input or vice versa. This programmability is best illustrated by the MUX addressing codes shown in the following tables for the various product options.

The MUX address is shifted into the converter via the DI line. Because the ADC0831-N contains only one differential input channel with a fixed polarity assignment, it does not require addressing.

The common input line on the ADC0838-N can be used as a pseudo-differential input. In this mode, the voltage on this pin is treated as the “-” input for any of the other input channels. This voltage does not have to be analog ground; it can be any reference potential which is common to all of the inputs. This feature is most useful in single-supply application where the analog circuitry may be biased up to a potential other than ground and the output signals are all referred to this potential.

Table 1. Multiplexer/Package Options Single-Ended MUX Mode

Part Number	Number of Analog Channels		Number of Package Pins
	Single-Ended	Differential	
ADC0831-N	1	1	8
ADC0832-N	2	1	8
ADC0834-N	4	2	14
ADC0838-N	8	4	20

Table 2. MUX Addressing: ADC0838-N Single-Ended MUX Mode

MUX Address				Analog Single-Ended Channel #								
SGL/ DIF	ODD/ SIGN	SELECT		0	1	2	3	4	5	6	7	COM
		1	0									
1	0	0	0	+								-
1	0	0	1			+						-
1	0	1	0					+				-
1	0	1	1							+		-
1	1	0	0		+							-
1	1	0	1				+					-
1	1	1	0						+			-
1	1	1	1								+	-

Table 3. MUX Addressing: ADC0838-N Differential MUX Mode

MUX Address				Analog Differential Channel-Pair #							
SGL/ $\overline{\text{DIF}}$	ODD/ SIGN	SELECT		0		1		2		3	
		1	0	0	1	2	3	4	5	6	7
0	0	0	0	+	-						
0	0	0	1			+	-				
0	0	1	0					+	-		
0	0	1	1							+	-
0	1	0	0	-	+						
0	1	0	1			-	+				
0	1	1	0					-	+		
0	1	1	1							-	+

Table 4. MUX Addressing: ADC0834-N Single-Ended MUX Mode

MUX Address			Channel #			
SGL / DIF	ODD / SIGN	SELECT	0	1	2	3
		1				
1	0	0	+			
1	0	1			+	
1	1	0		+		
1	1	1				+

Table 5. MUX Addressing: ADC0834-N Differential MUX Mode

MUX Address			Channel #			
SGL / DIF	ODD / SIGN	SELECT	0	1	2	3
		1				
0	0	0	+	-		
0	0	1			+	-
0	1	0	-	+		
0	1	1			-	+

Table 6. MUX Addressing: ADC0832-N Single-Ended MUX Mode

MUX Address		Channel #	
SGL / $\overline{\text{DIF}}$	ODD / SIGN	0	1
1	0	+	
1	1		+

Table 7. MUX Addressing: ADC0832-N Differential MUX Mode

MUX Address		Channel #	
SGL / $\overline{\text{DIF}}$	ODD / SIGN	0	1
0	0	+	-
0	1	-	+

Since the input configuration is under software control, it can be modified, as required, at each conversion. A channel can be treated as a single-ended, ground referenced input for one conversion; then it can be reconfigured as part of a differential channel for another conversion. [Figure 22](#) illustrates the input flexibility which can be achieved.

The analog input voltages for each channel can range from 50 mV below ground to 50 mV above V_{CC} (typically 5V) without degrading conversion accuracy.

THE DIGITAL INTERFACE

A most important characteristic of these converters is their serial data link with the controlling processor. Using a serial communication format offers two very significant system improvements; it allows more function to be included in the converter package with no increase in package size and it can eliminate the transmission of low level analog signals by locating the converter right at the analog sensor; transmitting highly noise immune digital data back to the host processor.

To understand the operation of these converters it is best to refer to the [Timing Diagrams](#) and [Functional Block Diagram](#) and to follow a complete conversion sequence. For clarity a separate diagram is shown of each device.

1. A conversion is initiated by first pulling the \overline{CS} (chip select) line low. This line must be held low for the entire conversion. The converter is now waiting for a start bit and its MUX assignment word.
2. A clock is then generated by the processor (if not provided continuously) and output to the A/D clock input.

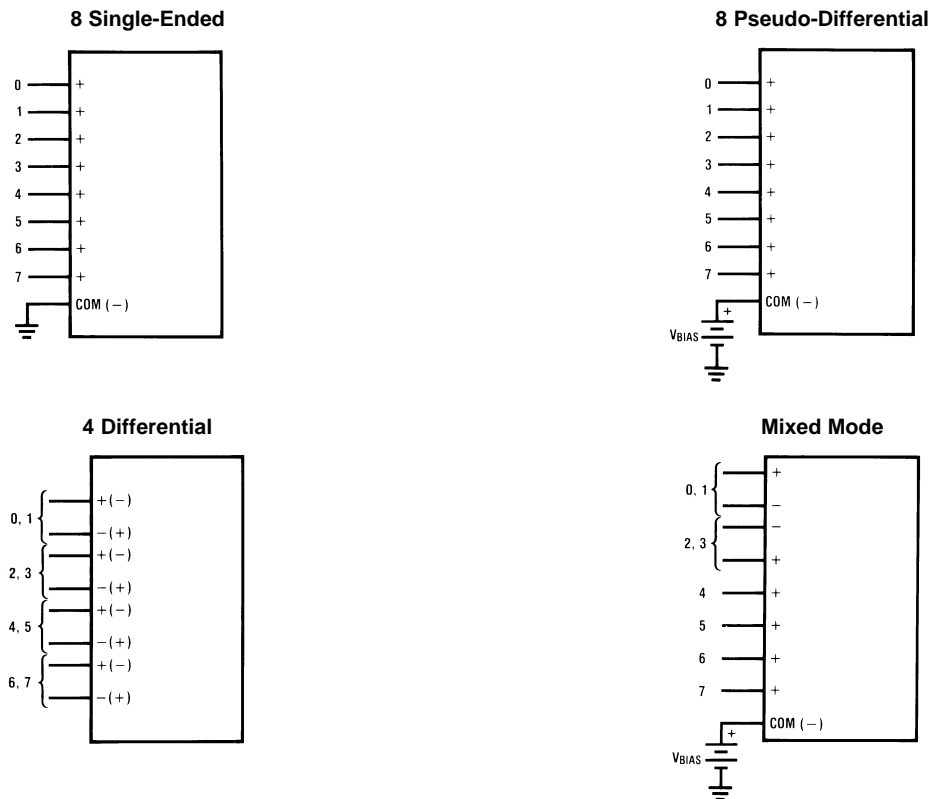

Figure 22. Analog Input Multiplexer Options for the ADC0838-N

3. On each rising edge of the clock the status of the data in (DI) line is clocked into the MUX address shift register. The start bit is the first logic "1" that appears on this line (all leading zeros are ignored). Following the start bit the converter expects the next 2 to 4 bits to be the MUX assignment word.
4. When the start bit has been shifted into the start location of the MUX register, the input channel has been assigned and a conversion is about to begin. An interval of $\frac{1}{2}$ clock period (where nothing happens) is automatically inserted to allow the selected MUX channel to settle. The SAR status line goes high at this time to signal that a conversion is now in progress and the DI line is disabled (it no longer accepts data).
5. The data out (DO) line now comes out of TRI-STATE and provides a leading zero for this one clock period of MUX settling time.
6. When the conversion begins, the output of the SAR comparator, which indicates whether the analog input is greater than (high) or less than (low) each successive voltage from the internal resistor ladder, appears at the DO line on each falling edge of the clock. This data is the result of the conversion being shifted out (with the MSB coming first) and can be read by the processor immediately.

7. After 8 clock periods the conversion is completed. The SAR status line returns low to indicate this ½ clock cycle later.

8. If the programmer prefers, the data can be provided in an LSB first format [this makes use of the shift enable (\overline{SE}) control line]. All 8 bits of the result are stored in an output shift register. On devices which do not include the \overline{SE} control line, the data, LSB first, is automatically shifted out the DO line, after the MSB first data stream. The DO line then goes low and stays low until \overline{CS} is returned high. On the ADC0838-N the \overline{SE} line is brought out and if held high, the value of the LSB remains valid on the DO line. When \overline{SE} is forced low, the data is then clocked out LSB first. The ADC0831-N is an exception in that its data is only output in MSB first format.

9. All internal registers are cleared when the \overline{CS} line is high. If another conversion is desired, \overline{CS} must make a high to low transition followed by address information.

The DI and DO lines can be tied together and controlled through a bidirectional processor I/O bit with one wire. This is possible because the DI input is only “looked-at” during the MUX addressing interval while the DO line is still in a high impedance state.

Reference Considerations

The voltage applied to the reference input to these converters defines the voltage span of the analog input (the difference between $V_{IN(MAX)}$ and $V_{IN(MIN)}$) over which the 256 possible output codes apply. The devices can be used in either ratiometric applications or in systems requiring absolute accuracy. The reference pin must be connected to a voltage source capable of driving the reference input resistance of typically 3.5 kΩ. This pin is the top of a resistor divider string used for the successive approximation conversion.

In a ratiometric system, the analog input voltage is proportional to the voltage used for the A/D reference. This voltage is typically the system power supply, so the V_{REF} pin can be tied to V_{CC} (done internally on the ADC0832-N). This technique relaxes the stability requirements of the system reference as the analog input and A/D reference move together maintaining the same output code for a given input condition.

For absolute accuracy, where the analog input varies between very specific voltage limits, the reference pin can be biased with a time and temperature stable voltage source. The LM385 and LM336 reference diodes are good low current devices to use with these converters.

The maximum value of the reference is limited to the V_{CC} supply voltage. The minimum value, however, can be quite small (see [Typical Performance Characteristics](#)) to allow direct conversions of transducer outputs providing less than a 5V output span. Particular care must be taken with regard to noise pickup, circuit layout and system error voltage sources when operating with a reduced span due to the increased sensitivity of the converter (1 LSB equals $V_{REF}/256$).

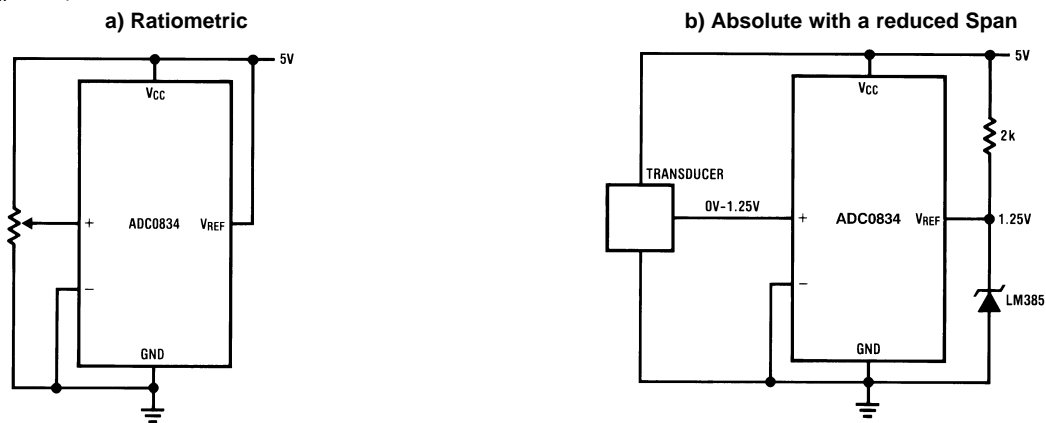

Figure 23. Reference Examples

The Analog Inputs

The most important feature of these converters is that they can be located right at the analog signal source and through just a few wires can communicate with a controlling processor with a highly noise immune serial bit stream. This in itself greatly minimizes circuitry to maintain analog signal accuracy which otherwise is most susceptible to noise pickup. However, a few words are in order with regard to the analog inputs should the input be noisy to begin with or possibly riding on a large common-mode voltage.

The differential input of these converters actually reduces the effects of common-mode input noise, a signal common to both selected “+” and “-” inputs for a conversion (60 Hz is most typical). The time interval between sampling the “+” input and then the “-” input is ½ of a clock period. The change in the common-mode voltage during this short time interval can cause conversion errors. For a sinusoidal common-mode signal this error is:

$$V_{\text{error(max)}} = V_{\text{PEAK}}(2\pi f_{\text{CM}}) \left(\frac{0.5}{f_{\text{CLK}}} \right)$$

where

- f_{CM} is the frequency of the common-mode signal
 - V_{PEAK} is its peak voltage value
 - f_{CLK} is the A/D clock frequency
- (1)

For a 60 Hz common-mode signal to generate a ¼ LSB error (≈5 mV) with the converter running at 250 kHz, its peak value would have to be 6.63V which would be larger than allowed as it exceeds the maximum analog input limits.

Due to the sampling nature of the analog inputs short spikes of current enter the “+” input and exit the “-” input at the clock edges during the actual conversion. These currents decay rapidly and do not cause errors as the internal comparator is strobed at the end of a clock period. Bypass capacitors at the inputs will average these currents and cause an effective DC current to flow through the output resistance of the analog signal source. Bypass capacitors should not be used if the source resistance is greater than 1 kΩ.

This source resistance limitation is important with regard to the DC leakage currents of input multiplexer as well. The worst-case leakage current of ±1 μA over temperature will create a 1 mV input error with a 1 kΩ source resistance. An op amp RC active low pass filter can provide both impedance buffering and noise filtering should a high impedance signal source be required.

Optional Adjustments

Zero Error

The zero of the A/D does not require adjustment. If the minimum analog input voltage value, $V_{\text{IN(MIN)}}$, is not ground a zero offset can be done. The converter can be made to output 0000 0000 digital code for this minimum input voltage by biasing any $V_{\text{IN}}(-)$ input at this $V_{\text{IN(MIN)}}$ value. This utilizes the differential mode operation of the A/D.

The zero error of the A/D converter relates to the location of the first riser of the transfer function and can be measured by grounding the $V_{\text{IN}}(-)$ input and applying a small magnitude positive voltage to the $V_{\text{IN}}(+)$ input. Zero error is the difference between the actual DC input voltage which is necessary to just cause an output digital code transition from 0000 0000 to 0000 0001 and the ideal ½ LSB value (½ LSB=9.8 mV for $V_{\text{REF}}=5.000 V_{\text{DC}}$).

Full-Scale

The full-scale adjustment can be made by applying a differential input voltage which is 1 ½ LSB down from the desired analog full-scale voltage range and then adjusting the magnitude of the V_{REF} input (or V_{CC} for the ADC0832) for a digital output code which is just changing from 1111 1110 to 1111 1111.

Adjusting for an Arbitrary Analog Input Voltage Range

If the analog zero voltage of the A/D is shifted away from ground (for example, to accommodate an analog input signal which does not go to ground), this new zero reference should be properly adjusted first. A $V_{IN(+)}$ voltage which equals this desired zero reference plus $\frac{1}{2}$ LSB (where the LSB is calculated for the desired analog span, using $1 \text{ LSB} = \text{analog span}/256$) is applied to selected “+” input and the zero reference voltage at the corresponding “-” input should then be adjusted to just obtain the 00_{HEX} to 01_{HEX} code transition.

The full-scale adjustment should be made [with the proper $V_{IN(-)}$ voltage applied] by forcing a voltage to the $V_{IN(+)}$ input which is given by:

$$V_{IN(+)} \text{ fs adj} = V_{\text{MAX}} - 1.5 \left[\frac{(V_{\text{MAX}} - V_{\text{MIN}})}{256} \right]$$

where

- V_{MAX} = the high end of the analog input range
- V_{MIN} = the low end (the offset zero) of the analog range. (Both are ground referenced.) (2)

The V_{REF} (or V_{CC}) voltage is then adjusted to provide a code change from FE_{HEX} to FF_{HEX} . This completes the adjustment procedure.

Power Supply

A unique feature of the ADC0838-N and ADC0834-N is the inclusion of a zener diode connected from the V^+ terminal to ground which also connects to the V_{CC} terminal (which is the actual converter supply) through a silicon diode, as shown in Figure 24⁽¹⁾.

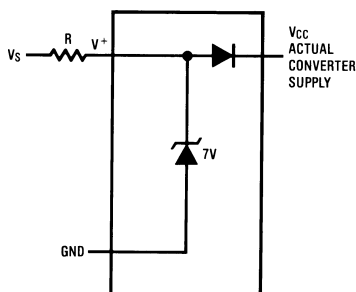

Figure 24. An On-Chip Shunt Regulator Diode

This zener is intended for use as a shunt voltage regulator to eliminate the need for any additional regulating components. This is most desirable if the converter is to be remotely located from the system power source. Figure 25 and Figure 27 illustrate two useful applications of this on-board zener when an external transistor can be afforded.

An important use of the interconnecting diode between V^+ and V_{CC} is shown in Figure 26 and Figure 28. Here, this diode is used as a rectifier to allow the V_{CC} supply for the converter to be derived from the clock. The low current requirements of the A/D and the relatively high clock frequencies used (typically in the range of 10k–400 kHz) allows using the small value filter capacitor shown to keep the ripple on the V_{CC} line to well under $\frac{1}{4}$ of an LSB. The shunt zener regulator can also be used in this mode. This requires a clock voltage swing which is in excess of V_Z . A current limit for the zener is needed, either built into the clock generator or a resistor can be used from the CLK pin to the V^+ pin.

- (1) Internal zener diodes (6.3 to 8.5V) are connected from V^+ to GND and V_{CC} to GND. The zener at V^+ can operate as a shunt regulator and is connected to V_{CC} via a conventional diode. Since the zener voltage equals the A/D's breakdown voltage, the diode insures that V_{CC} will be below breakdown when the device is powered from V^+ . Functionality is therefore ensured for V^+ operation even though the resultant voltage at V_{CC} may exceed the specified Absolute Max of 6.5V. It is recommended that a resistor be used to limit the max current into V^+ . (See Figure 24 in Functional Description)

APPLICATIONS

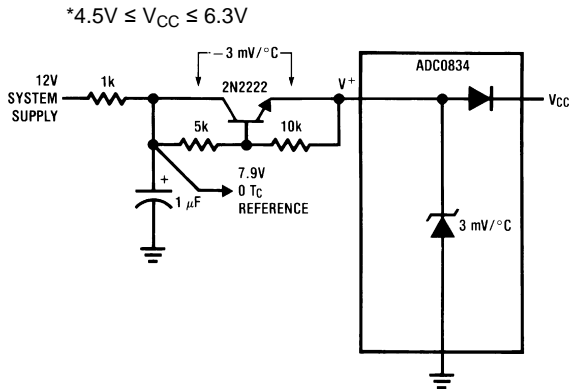

Figure 25. Operating with a Temperature Compensated Reference

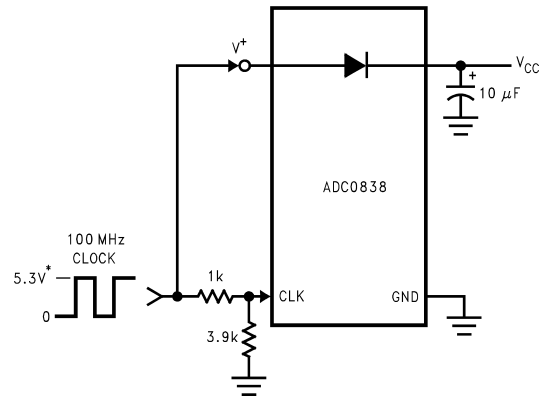

Figure 26. Generating V_{CC} from the Converter Clock

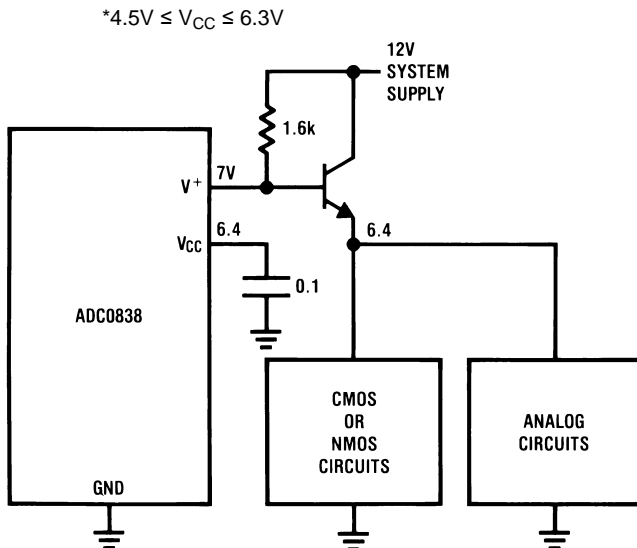

Figure 27. Using the A/D as the System Supply Regulator

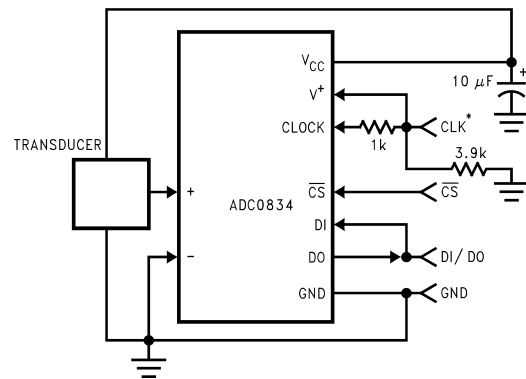

Figure 28. Remote Sensing—Clock and Power on 1 Wire

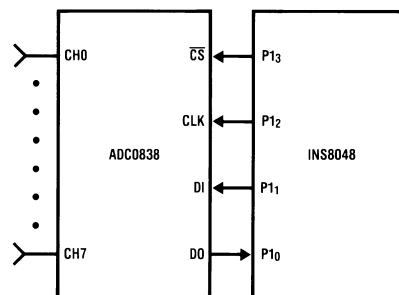
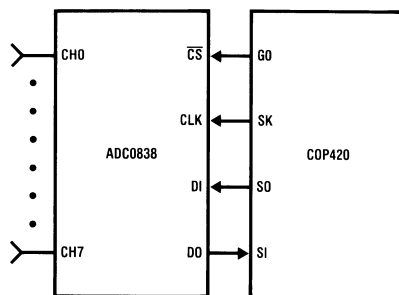

Figure 29. Digital Link and Sample Controlling Software for the Serially Oriented COP420 and the Bit Programmable I/O INS8048

Cop Coding Example

Mnemonic	Instruction
LEI	ENABLES SIO's INPUT AND OUTPUT
SC	C = 1
OGI	G0 = 0 ($\overline{\text{CS}} = 0$)
CLR A	CLEARs ACCUMULATOR
AISC 1	LOADS ACCUMULATOR WITH 1
XAS	EXCHANGES SIO WITH ACCUMULATOR AND STARTS SK CLOCK
LDD	LOADS MUX ADDRESS FROM RAM INTO ACCUMULATOR
NOP	-
XAS	LOADS MUX ADDRESS FROM ACCUMULATOR
	↑
	8 INSTRUCTIONS
	↓
XAS	READS HIGH ORDER NIBBLE (4 BITS) INTO ACCUMULATOR
XIS	PUTS HIGH ORDER NIBBLE INTO RAM
CLER A	CLEARs ACCUMULATOR
RC	C = 0
XAS	READS LOW ORDER NIBBLE INTO ACCUMULATOR AND STOPS SK
XIS	PUTS LOW ORDER NIBBLE INTO RAM
OGI	G0 = 1 ($\overline{\text{CS}} = 1$)
LEI	DISABLES SIO's INPUT AND OUTPUT

8048 Coding Example

Mnemonic	Instruction
START:	ANL P1, #0F7H ;SELECT A/D ($\overline{\text{CS}} = 0$)
	MOV B, #5 ;BIT COUNTER-5
	MOV A, #ADDR ;A-MUX ADDRESS
LOOP 1:	RRC A ;CY-ADDRESS BIT
	JC ONE ;TEST BIT
	;BIT=0
ZERO:	ANL P1, #0FEH ;DI-0
	JMP CONT ;CONTINUE
	;BIT=1
ONE:	ORL P1, #1 ;DI-1
CONT:	CALL PULSE ;PULSE SK 0-1-0
	DJNZ B, LOOP 1 ;CONTINUE UNTIL DONE
	CALL PULSE ;EXTRA CLOCK FOR SYNC
	MOV B, #8 ;BIT COUNTER-8
LOOP 2:	CALL PULSE ;PULSE SK 0-1-0
	IN A, P1 ;CY-DO
	RRC A
	RRC A
	MOV A, C ;A-RESULT
	RLC A ;A(0)-BIT AND SHIFT
	MOV C, A ;C-RESULT
	DJNZ B, LOOP 2 ;CONTINUE UNTIL DONE
RETR	;PULSE SUBROUTINE
PULSE:	ORL P1, #04 ;SK-1
	NOP ;DELAY
	ANL P1, #0FBH ;SK-0
	RET

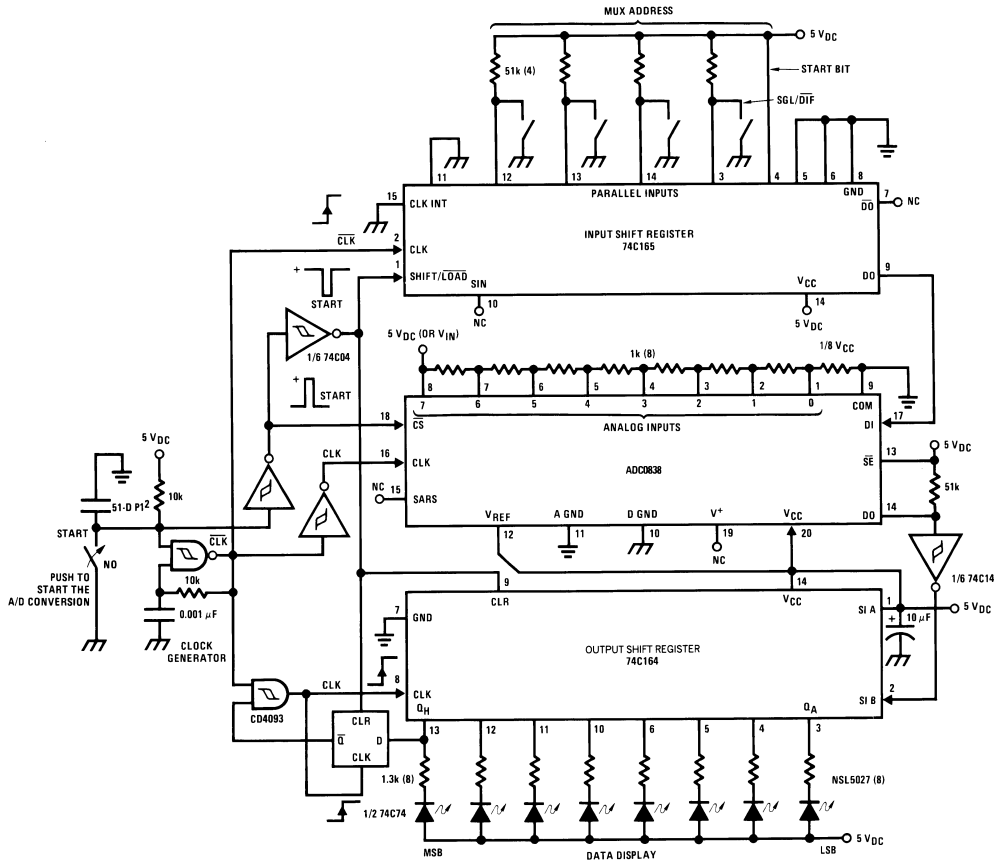

*Pinouts shown for ADC0838-N.
For all other products tie to pin functions as shown.

Figure 30. A “Stand-Alone” Hook-Up for ADC0838-N Evaluation

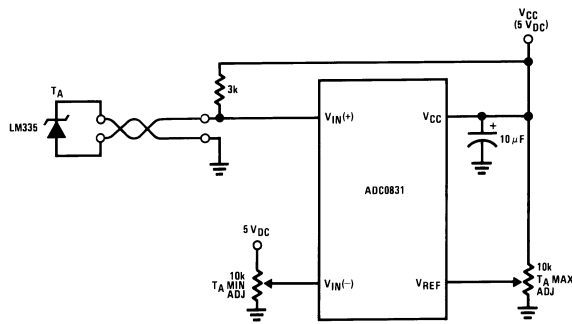

Figure 31. Low-Cost Remote Temperature Sensor

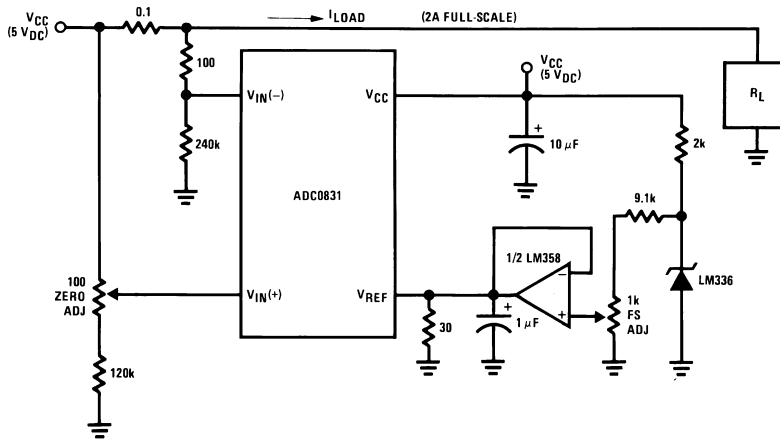
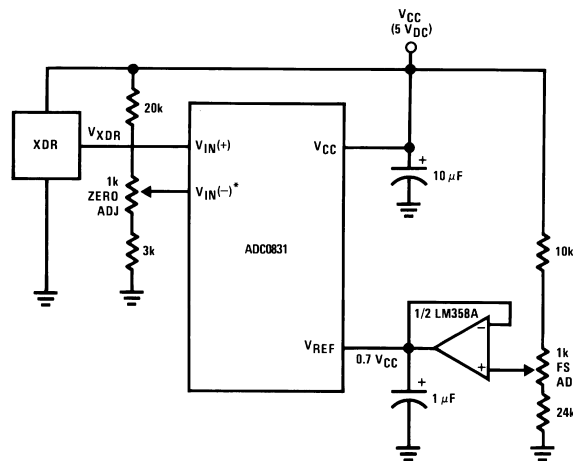

Figure 32. Digitizing a Current Flow



* $V_{IN(-)} = 0.15 V_{CC}$
 $15\% \text{ of } V_{CC} \leq V_{XDR} \leq 85\% \text{ of } V_{CC}$

Figure 33. Operating with Ratiometric Transducers

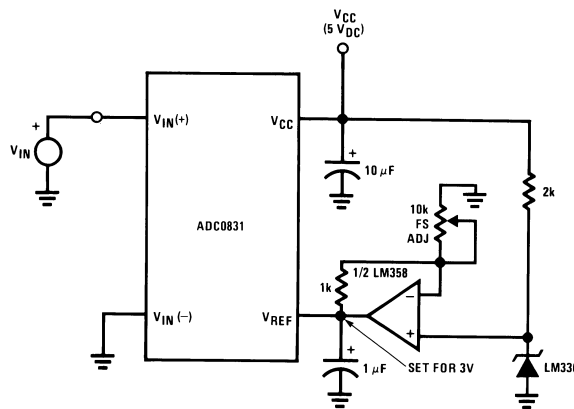

Figure 34. Span Adjust: $0V \leq V_{IN} \leq 3V$

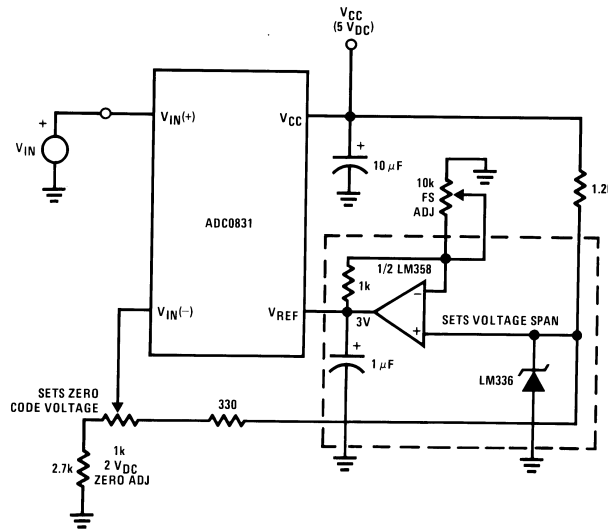

Figure 35. Zero-Shift and Span Adjust: $2V \leq V_{IN} \leq 5V$

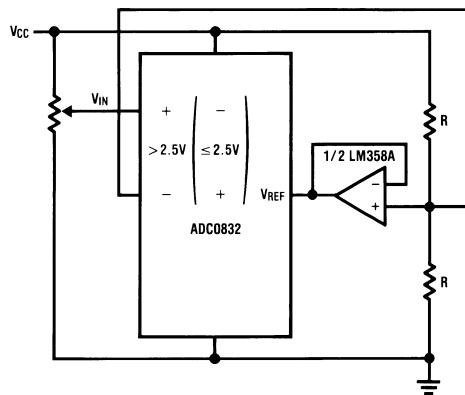
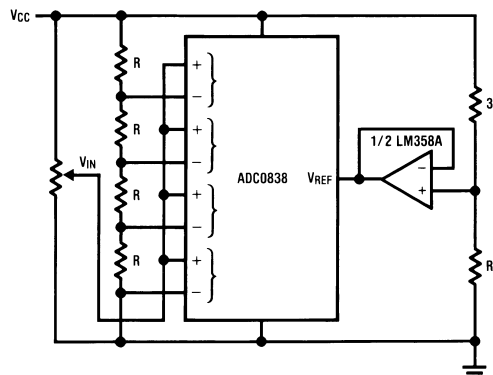
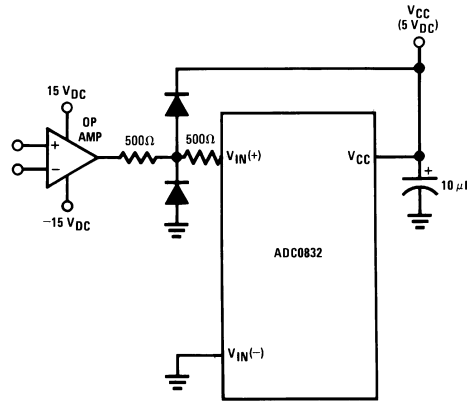

Figure 36. Obtaining Higher Resolution - 9-Bit A/D



Controller performs a routine to determine which input polarity (9-bit example) or which channel pair (10-bit example) provides a non-zero output code. This information provides the extra bits.

Figure 37. Obtaining Higher Resolution - 10-Bit A/D



Diodes are 1N914

Figure 38. Protecting the Input

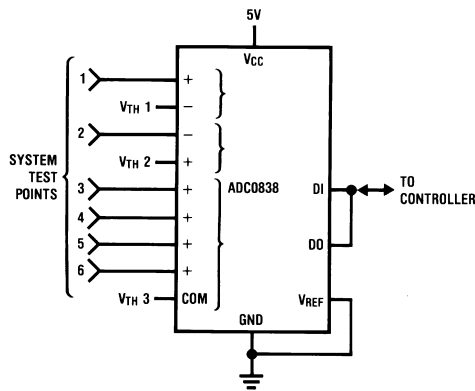

DO = all 1s if $+V_{IN} > -V_{IN}$
 DO = all 0s if $+V_{IN} < -V_{IN}$

Figure 39. High Accuracy Comparators

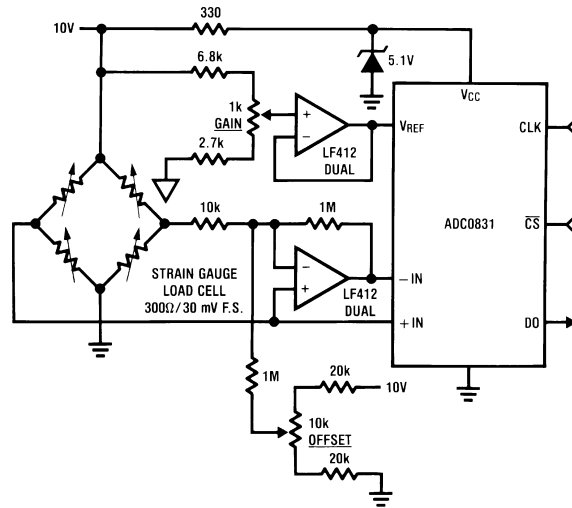

- Uses one more wire than load cell itself
- Two mini-DIPs could be mounted inside load cell for digital output transducer
- Electronic offset and gain trims relax mechanical specs for gauge factor and offset
- Low level cell output is converted immediately for high noise immunity

Figure 40. Digital Load Cell

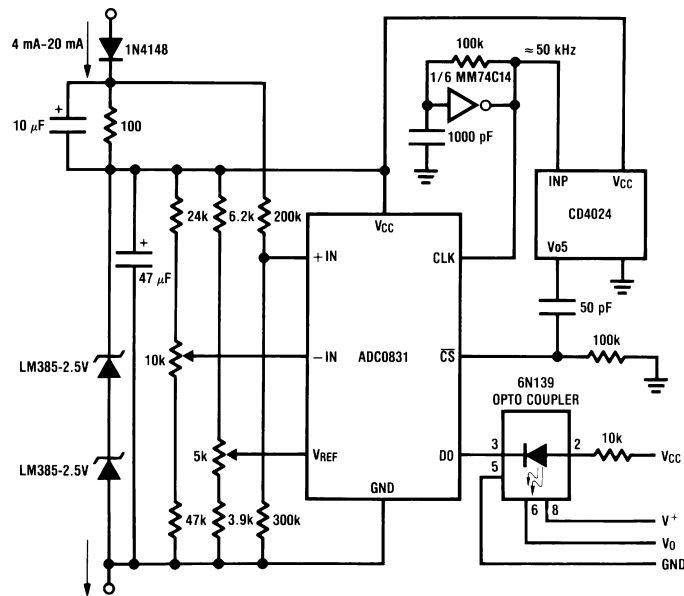

- All power supplied by loop
- 1500V isolation at output

Figure 41. 4 mA-20 mA Current Loop Converter

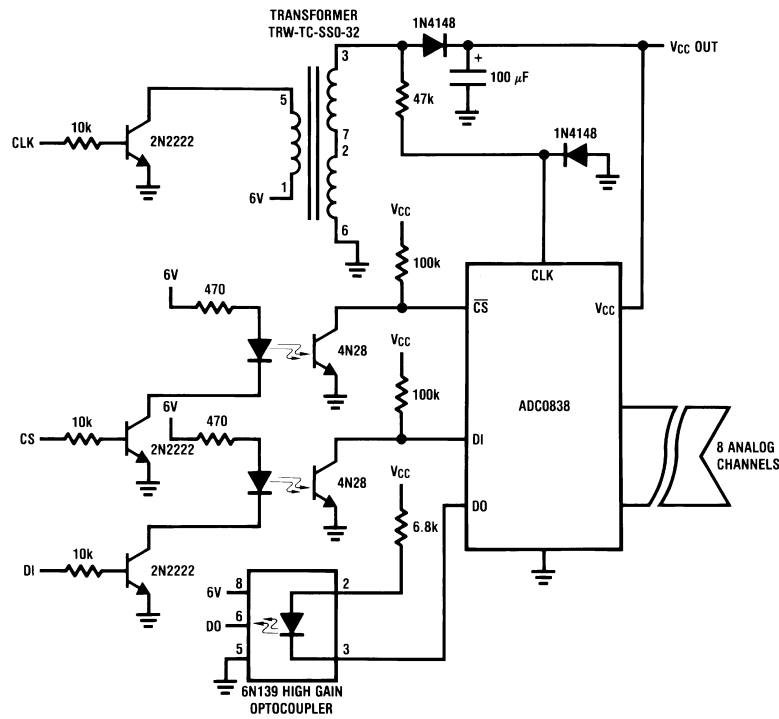

- No power required remotely
- 1500V isolation

Figure 42. Isolated Data Converter

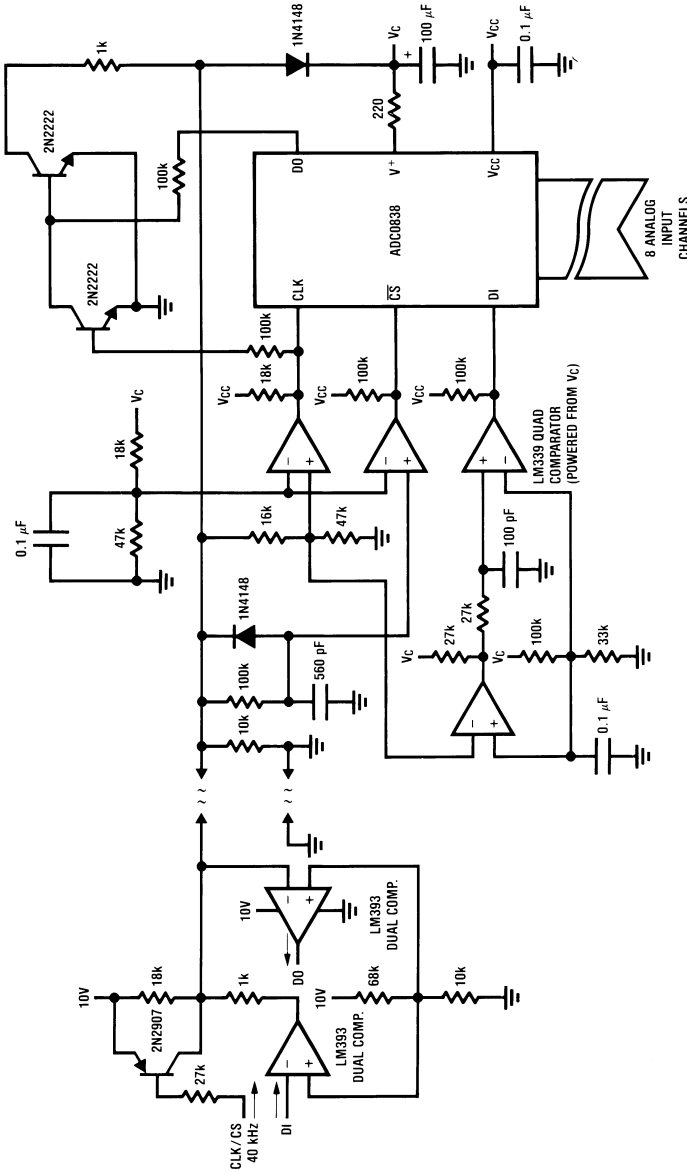

- No additional connections
- CS derived from extended high on CLK line > 100 μs
- Timing arranged for 40 kHz, could be changed up or down by component change
- 10% CLK frequency change without component change OK

Figure 43. Two Wire Interface for 8 Channels

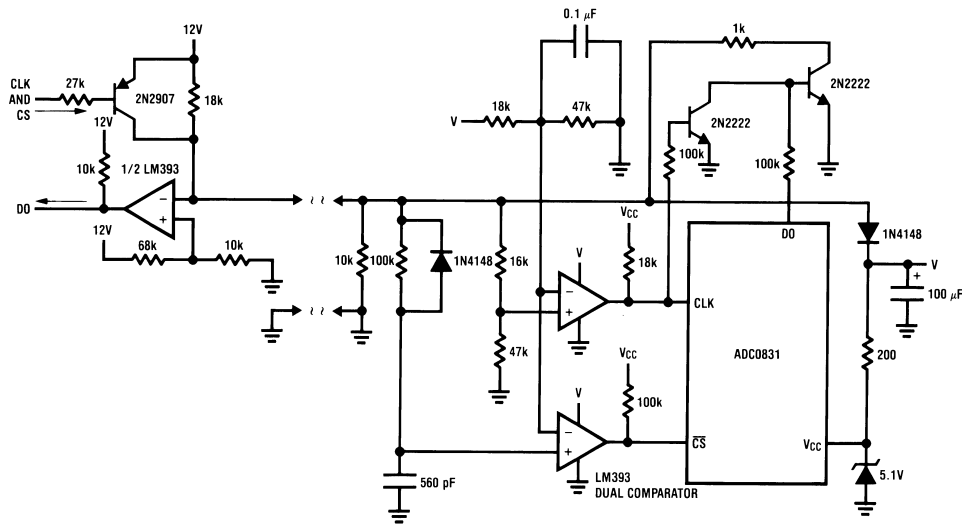

- Simpler version of 8-channel
- CS derived from long CLK pulse

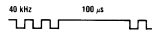

Figure 44. Two Wire 1-Channels Interface

REVISION HISTORY

Changes from Revision A (March 2013) to Revision B	Page
<hr/> <ul style="list-style-type: none">• Changed layout of National Data Sheet to TI format	<hr/> 28

PACKAGING INFORMATION

Orderable Device	Status (1)	Package Type	Package Drawing	Pins	Package Qty	Eco Plan (2)	Lead finish/ Ball material (6)	MSL Peak Temp (3)	Op Temp (°C)	Device Marking (4/5)	Samples
ADC0831CCWM/NOPB	ACTIVE	SOIC	NPA	14	50	RoHS & Green	SN	Level-3-260C-168 HR	-40 to 85	ADC0831 CCWM	Samples
ADC0831CCWMX/NOPB	ACTIVE	SOIC	NPA	14	1000	RoHS & Green	SN	Level-3-260C-168 HR	-40 to 85	ADC0831 CCWM	Samples
ADC0832CCWM/NOPB	ACTIVE	SOIC	NPA	14	50	RoHS & Green	SN	Level-3-260C-168 HR	-40 to 85	ADC0832 CCWM	Samples
ADC0832CCWMX/NOPB	ACTIVE	SOIC	NPA	14	1000	RoHS & Green	SN	Level-3-260C-168 HR	-40 to 85	ADC0832 CCWM	Samples
ADC0834CCWM/NOPB	ACTIVE	SOIC	NPA	14	50	RoHS & Green	SN	Level-3-260C-168 HR	-40 to 85	ADC0834 CCWM	Samples
ADC0834CCWMX/NOPB	ACTIVE	SOIC	NPA	14	1000	RoHS & Green	SN	Level-3-260C-168 HR	-40 to 85	ADC0834 CCWM	Samples
ADC0838CCWM/NOPB	ACTIVE	SOIC	DW	20	36	RoHS & Green	SN	Level-3-260C-168 HR	-40 to 85	ADC0838 CCWM	Samples
ADC0838CCWMX/NOPB	ACTIVE	SOIC	DW	20	1000	RoHS & Green	SN	Level-3-260C-168 HR	-40 to 85	ADC0838 CCWM	Samples
ADC0838CIWM/NOPB	ACTIVE	SOIC	DW	20	36	RoHS & Green	SN	Level-3-260C-168 HR	-40 to 85	ADC0838 CIWM	Samples
ADC0838CIWMX/NOPB	ACTIVE	SOIC	DW	20	1000	RoHS & Green	SN	Level-3-260C-168 HR	-40 to 85	ADC0838 CIWM	Samples

(1) The marketing status values are defined as follows:

ACTIVE: Product device recommended for new designs.

LIFEBUY: TI has announced that the device will be discontinued, and a lifetime-buy period is in effect.

NRND: Not recommended for new designs. Device is in production to support existing customers, but TI does not recommend using this part in a new design.

PREVIEW: Device has been announced but is not in production. Samples may or may not be available.

OBSELETE: TI has discontinued the production of the device.

(2) **RoHS:** TI defines "RoHS" to mean semiconductor products that are compliant with the current EU RoHS requirements for all 10 RoHS substances, including the requirement that RoHS substance do not exceed 0.1% by weight in homogeneous materials. Where designed to be soldered at high temperatures, "RoHS" products are suitable for use in specified lead-free processes. TI may reference these types of products as "Pb-Free".

RoHS Exempt: TI defines "RoHS Exempt" to mean products that contain lead but are compliant with EU RoHS pursuant to a specific EU RoHS exemption.

Green: TI defines "Green" to mean the content of Chlorine (Cl) and Bromine (Br) based flame retardants meet JS709B low halogen requirements of <=1000ppm threshold. Antimony trioxide based flame retardants must also meet the <=1000ppm threshold requirement.

- (3) MSL, Peak Temp. - The Moisture Sensitivity Level rating according to the JEDEC industry standard classifications, and peak solder temperature.
- (4) There may be additional marking, which relates to the logo, the lot trace code information, or the environmental category on the device.
- (5) Multiple Device Markings will be inside parentheses. Only one Device Marking contained in parentheses and separated by a "~" will appear on a device. If a line is indented then it is a continuation of the previous line and the two combined represent the entire Device Marking for that device.
- (6) Lead finish/Ball material - Orderable Devices may have multiple material finish options. Finish options are separated by a vertical ruled line. Lead finish/Ball material values may wrap to two lines if the finish value exceeds the maximum column width.

Important Information and Disclaimer:The information provided on this page represents TI's knowledge and belief as of the date that it is provided. TI bases its knowledge and belief on information provided by third parties, and makes no representation or warranty as to the accuracy of such information. Efforts are underway to better integrate information from third parties. TI has taken and continues to take reasonable steps to provide representative and accurate information but may not have conducted destructive testing or chemical analysis on incoming materials and chemicals. TI and TI suppliers consider certain information to be proprietary, and thus CAS numbers and other limited information may not be available for release.

In no event shall TI's liability arising out of such information exceed the total purchase price of the TI part(s) at issue in this document sold by TI to Customer on an annual basis.

TAPE AND REEL INFORMATION

QUADRANT ASSIGNMENTS FOR PIN 1 ORIENTATION IN TAPE



*All dimensions are nominal

Device	Package Type	Package Drawing	Pins	SPQ	Reel Diameter (mm)	Reel Width W1 (mm)	A0 (mm)	B0 (mm)	K0 (mm)	P1 (mm)	W (mm)	Pin1 Quadrant
ADC0831CCWMX/NOPB	SOIC	NPA	14	1000	330.0	16.4	10.9	9.5	3.2	12.0	16.0	Q1
ADC0832CCWMX/NOPB	SOIC	NPA	14	1000	330.0	16.4	10.9	9.5	3.2	12.0	16.0	Q1
ADC0834CCWMX/NOPB	SOIC	NPA	14	1000	330.0	16.4	10.9	9.5	3.2	12.0	16.0	Q1
ADC0838CCWMX/NOPB	SOIC	DW	20	1000	330.0	24.4	10.9	13.3	3.25	12.0	24.0	Q1
ADC0838CIWMX/NOPB	SOIC	DW	20	1000	330.0	24.4	10.9	13.3	3.25	12.0	24.0	Q1

TAPE AND REEL BOX DIMENSIONS

*All dimensions are nominal

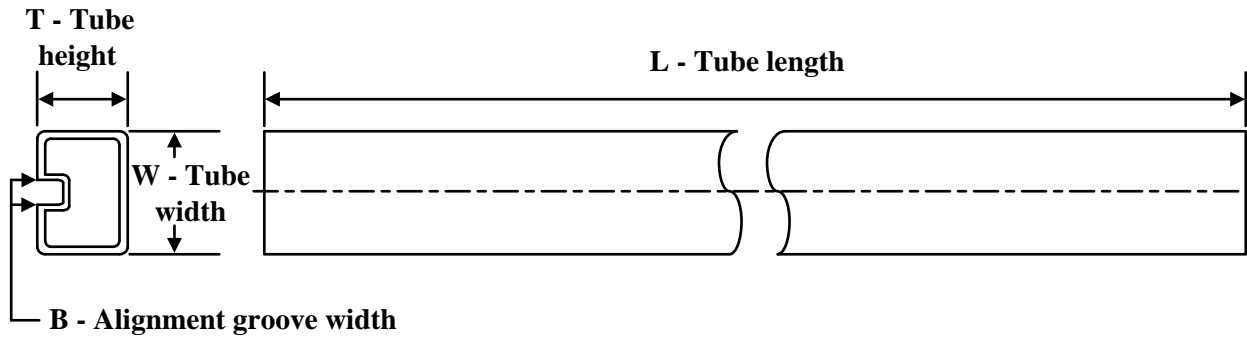
Device	Package Type	Package Drawing	Pins	SPQ	Length (mm)	Width (mm)	Height (mm)
ADC0831CCWMX/NOPB	SOIC	NPA	14	1000	356.0	356.0	36.0
ADC0832CCWMX/NOPB	SOIC	NPA	14	1000	356.0	356.0	36.0
ADC0834CCWMX/NOPB	SOIC	NPA	14	1000	356.0	356.0	36.0
ADC0838CCWMX/NOPB	SOIC	DW	20	1000	356.0	356.0	45.0
ADC0838CIWMX/NOPB	SOIC	DW	20	1000	356.0	356.0	45.0

TUBE

*All dimensions are nominal

Device	Package Name	Package Type	Pins	SPQ	L (mm)	W (mm)	T (μm)	B (mm)
ADC0831CCWM/NOPB	NPA	SOIC	14	50	495	15	5842	7.87
ADC0832CCWM/NOPB	NPA	SOIC	14	50	495	15	5842	7.87
ADC0834CCWM/NOPB	NPA	SOIC	14	50	495	15	5842	7.87
ADC0838CCWM/NOPB	DW	SOIC	20	36	495	15	5842	7.87
ADC0838CIWM/NOPB	DW	SOIC	20	36	495	15	5842	7.87

DW0020A



PACKAGE OUTLINE

SOIC - 2.65 mm max height

SOIC

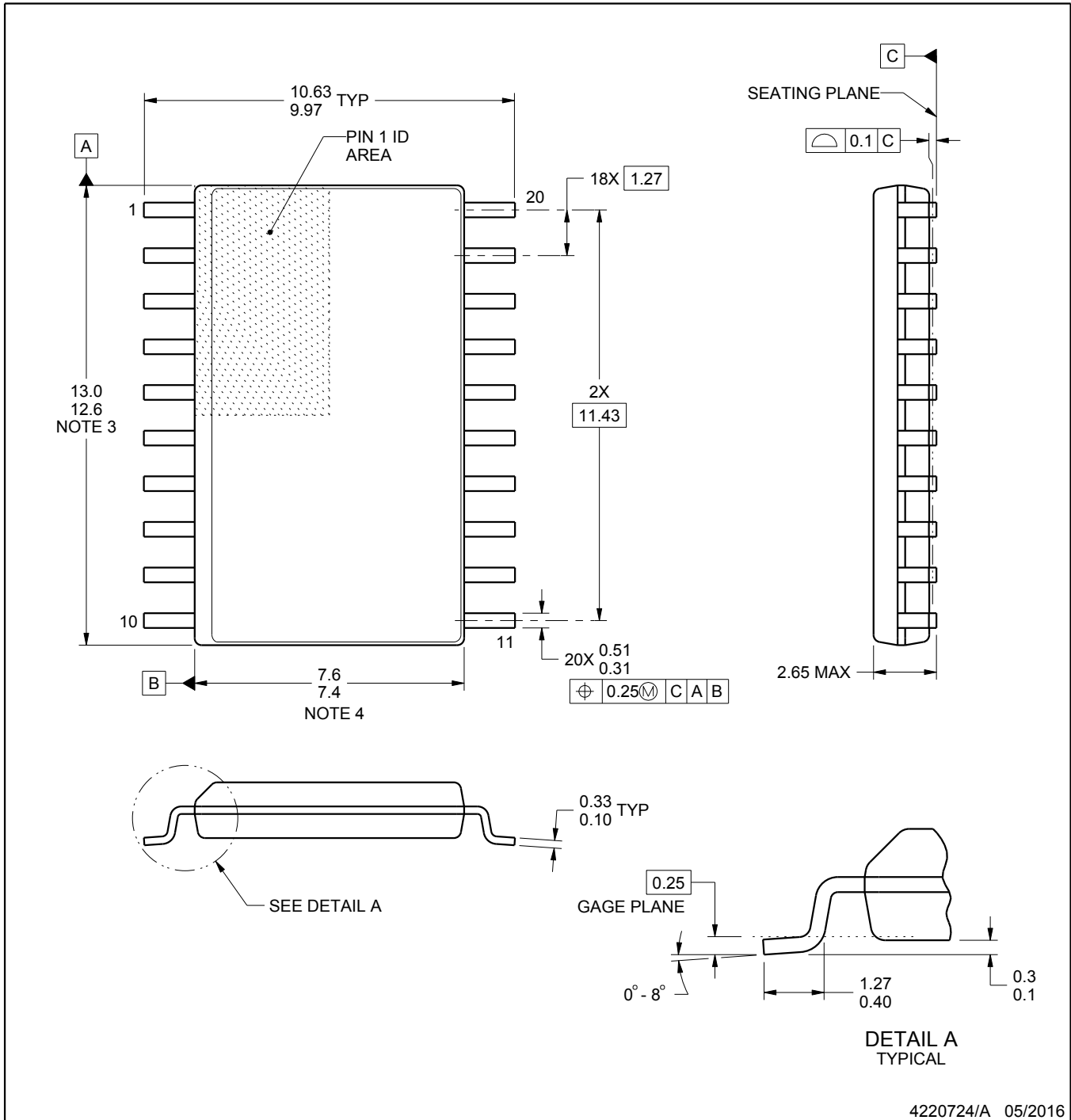

4220724/A 05/2016

NOTES:

1. All linear dimensions are in millimeters. Dimensions in parenthesis are for reference only. Dimensioning and tolerancing per ASME Y14.5M.
2. This drawing is subject to change without notice.
3. This dimension does not include mold flash, protrusions, or gate burrs. Mold flash, protrusions, or gate burrs shall not exceed 0.15 mm per side.
4. This dimension does not include interlead flash. Interlead flash shall not exceed 0.43 mm per side.
5. Reference JEDEC registration MS-013.

EXAMPLE BOARD LAYOUT

DW0020A

SOIC - 2.65 mm max height

SOIC



LAND PATTERN EXAMPLE
SCALE:6X



SOLDER MASK DETAILS

4220724/A 05/2016

NOTES: (continued)

- 6. Publication IPC-7351 may have alternate designs.
- 7. Solder mask tolerances between and around signal pads can vary based on board fabrication site.

EXAMPLE STENCIL DESIGN

DW0020A

SOIC - 2.65 mm max height

SOIC

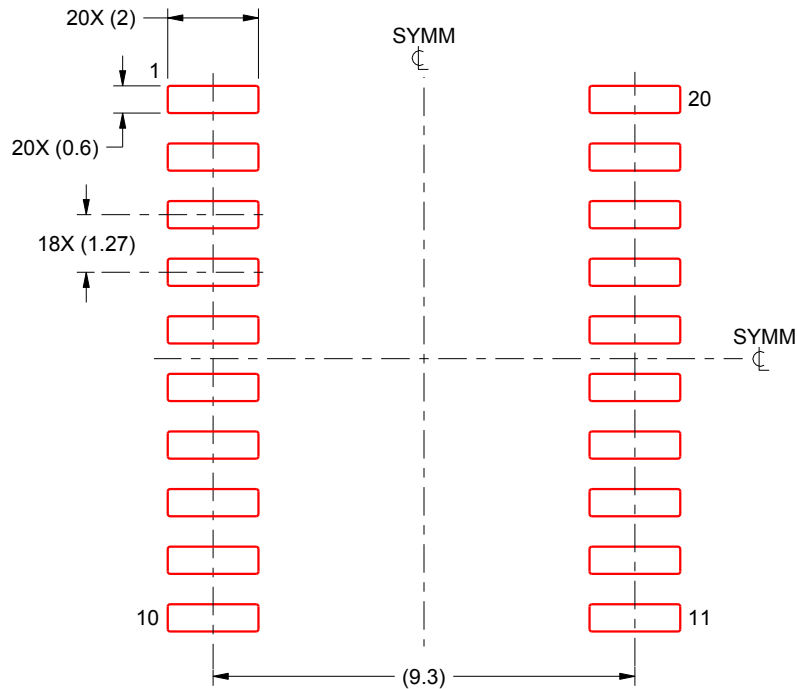

SOLDER PASTE EXAMPLE
BASED ON 0.125 mm THICK STENCIL
SCALE:6X

4220724/A 05/2016

NOTES: (continued)

8. Laser cutting apertures with trapezoidal walls and rounded corners may offer better paste release. IPC-7525 may have alternate design recommendations.
9. Board assembly site may have different recommendations for stencil design.

NPA0014B

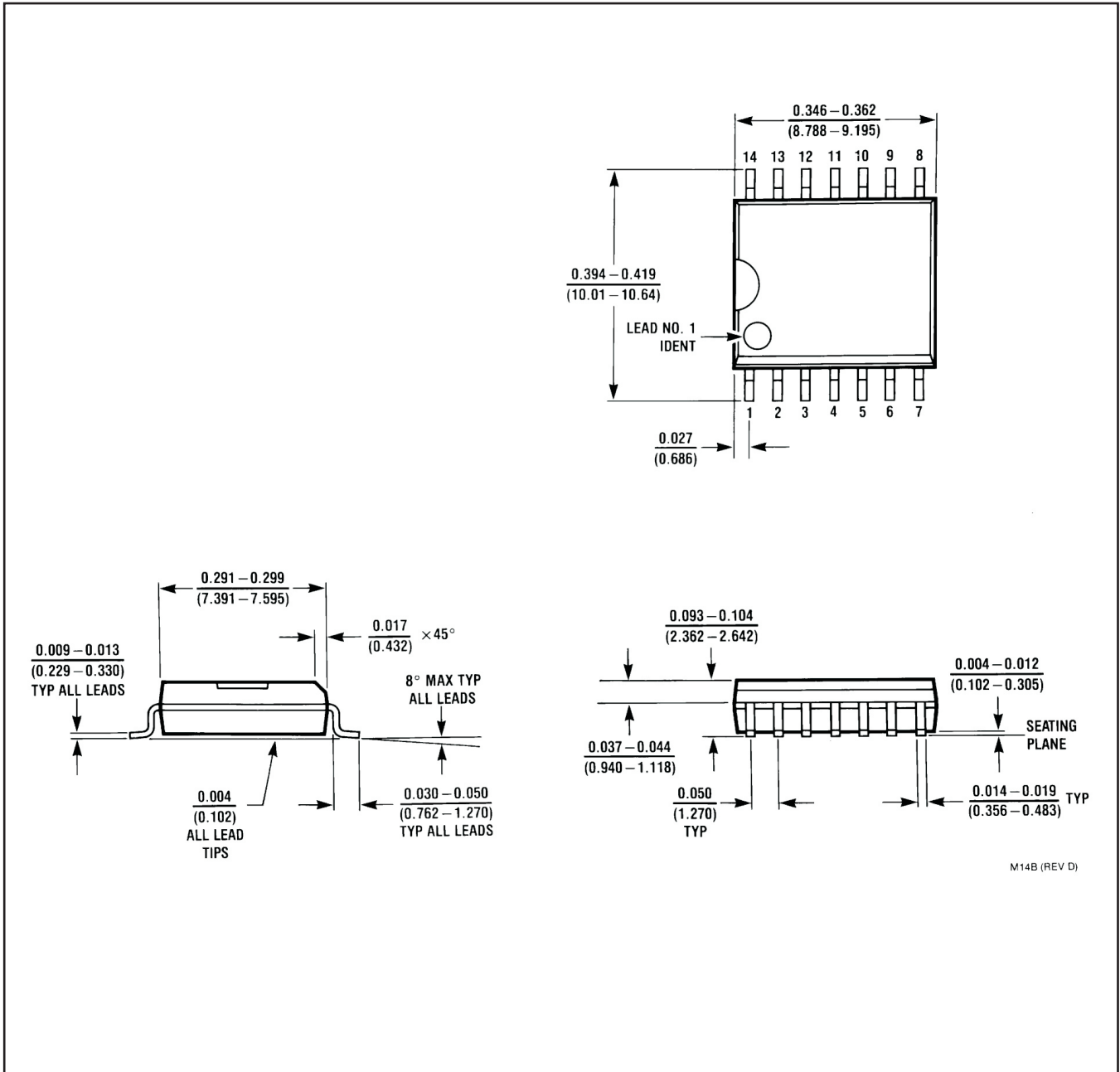

IMPORTANT NOTICE AND DISCLAIMER

TI PROVIDES TECHNICAL AND RELIABILITY DATA (INCLUDING DATA SHEETS), DESIGN RESOURCES (INCLUDING REFERENCE DESIGNS), APPLICATION OR OTHER DESIGN ADVICE, WEB TOOLS, SAFETY INFORMATION, AND OTHER RESOURCES "AS IS" AND WITH ALL FAULTS, AND DISCLAIMS ALL WARRANTIES, EXPRESS AND IMPLIED, INCLUDING WITHOUT LIMITATION ANY IMPLIED WARRANTIES OF MERCHANTABILITY, FITNESS FOR A PARTICULAR PURPOSE OR NON-INFRINGEMENT OF THIRD PARTY INTELLECTUAL PROPERTY RIGHTS.

These resources are intended for skilled developers designing with TI products. You are solely responsible for (1) selecting the appropriate TI products for your application, (2) designing, validating and testing your application, and (3) ensuring your application meets applicable standards, and any other safety, security, regulatory or other requirements.

These resources are subject to change without notice. TI grants you permission to use these resources only for development of an application that uses the TI products described in the resource. Other reproduction and display of these resources is prohibited. No license is granted to any other TI intellectual property right or to any third party intellectual property right. TI disclaims responsibility for, and you will fully indemnify TI and its representatives against, any claims, damages, costs, losses, and liabilities arising out of your use of these resources.

TI's products are provided subject to [TI's Terms of Sale](#) or other applicable terms available either on [ti.com](https://www.ti.com) or provided in conjunction with such TI products. TI's provision of these resources does not expand or otherwise alter TI's applicable warranties or warranty disclaimers for TI products.

TI objects to and rejects any additional or different terms you may have proposed.

Mailing Address: Texas Instruments, Post Office Box 655303, Dallas, Texas 75265
Copyright © 2024, Texas Instruments Incorporated

Looking for pricing, stock, or lifecycle information?

Click below to explore more details on WIN SOURCE:

- ⊖ [View MCP73833T-FCI/UN on WIN SOURCE](#)
- ⊖ [Microchip Technology](#) Information

Optimize Your Supply Chain with WIN SOURCE Solutions

- ✓ Global Sourcing Solution
- ✓ Obsolete Management
- ✓ Cost Control Management
- ✓ Shortage Management
- ✓ Alternative Solution
- ✓ Excess Inventory Management