



**THE DATASHEET OF
DEMO9S08AW60E**





DEMO9S08AW60E

User's Guide

How to Reach Us:

USA/Europe/Locations not listed:

Freescale Semiconductor Literature Distribution
P.O. Box 5405, Denver, Colorado 80217
1-800-521-6274 or 480-768-2130

Japan:

Freescale Semiconductor Japan Ltd.
SPS, Technical Information Center
3-20-1, Minami-Azabu
Minato-ku
Tokyo 106-8573, Japan
81-3-3440-3569

Asia/Pacific:

Freescale Semiconductor H.K. Ltd.
2 Dai King Street
Tai Po Industrial Estate
Tai Po, N.T. Hong Kong
852-26668334

Learn More:

For more information about Freescale Semiconductor products, please visit
<http://www.freescale.com>

Information in this document is provided solely to enable system and software implementers to use Freescale Semiconductor products. There are no express or implied copyright licenses granted hereunder to design or fabricate any integrated circuits or integrated circuits based on the information in this document.

Freescale Semiconductor reserves the right to make changes without further notice to any products herein. Freescale Semiconductor makes no warranty, representation or guarantee regarding the suitability of its products for any particular purpose, nor does Freescale Semiconductor assume any liability arising out of the application or use of any product or circuit, and specifically disclaims any and all liability, including without limitation consequential or incidental damages. "Typical" parameters which may be provided in Freescale Semiconductor data sheets and/or specifications can and do vary in different applications and actual performance may vary over time. All operating parameters, including "Typicals" must be validated for each customer application by customer's technical experts. Freescale Semiconductor does not convey any license under its patent rights nor the rights of others. Freescale Semiconductor products are not designed, intended, or authorized for use as components in systems intended for surgical implant into the body, or other applications intended to support or sustain life, or for any other application in which the failure of the Freescale Semiconductor product could create a situation where personal injury or death may occur. Should Buyer purchase or use Freescale Semiconductor products for any such unintended or unauthorized application, Buyer shall indemnify and hold Freescale Semiconductor and its officers, employees, subsidiaries, affiliates, and distributors harmless against all claims, costs, damages, and expenses, and reasonable attorney fees arising out of, directly or indirectly, any claim of personal injury or death associated with such unintended or unauthorized use, even if such claim alleges that Freescale Semiconductor was negligent regarding the design or manufacture of the part.

Freescale™ and the Freescale logo are trademarks of Freescale Semiconductor, Inc. All other product or service names are the property of their respective owners.

© Freescale Semiconductor, Inc. 2006.

Table of Contents

Section 1.

1.1	Introduction.....	9
1.2	System Requirements.....	9
1.3	DEMO9S08AW60E Layout.....	10
1.4	Features.....	11
1.5	References.....	12
1.6	Getting Started.....	12
1.7	Memory Map.....	12
1.8	Development Support.....	12
1.8.1	Integrated BDM.....	13
1.8.2	BDM Header.....	13
1.8.3	Socketed MCU.....	13
1.9	Power.....	14
1.9.1	USB-BDM Interface.....	14
1.9.2	External Power Jack.....	14
1.9.3	I/O Connector.....	15
1.9.4	3 Volt Operation.....	16
1.10	Reset Switch.....	16
1.11	Clock Source.....	16
1.12	RS-232.....	16
1.13	User Options.....	17
1.13.1	Pushbutton Switches.....	17
1.13.2	Light Bar.....	18
1.13.3	Rocker Switches.....	19
1.13.4	Accelerometer.....	19
1.13.5	Light Sensor.....	20

1.13.6	Potentiometer	20
1.13.7	I/O Connector	20

List of Figures

1-1	DEMO9S08AW60E Top Side	10
-----	------------------------------	----

List of Tables

1-1	MC9S08AW60 Memory Map	12
1-2	BDM Connector (J32) Pinout	13
1-3	Jumper Settings in USB Power Mode	14
1-4	Jumper Settings in EXT Power Mode	15
1-5	Jumper Settings in I/O Connector Power Mode	15
1-6	RS-232 Connections	16
1-7	COM Connector (J34) Pinout	17
1-8	Pushbutton Switch (SW1 - SW4) Connections	18
1-9	Light Bar (LED1) Connections	18
1-10	Rocker Switch (SW5) Connections	19
1-11	Accelerometer (U5) Connections	20
1-12	I/O Connector (J35) Pinout	21

Section 1.

1.1 Introduction

The DEMO9S08AW60E is a demonstration board for the Freescale MC9S08AW60. Through the on-board BDM port, the DEMO9S08AW60E allows users to develop code and evaluate the MC9S08AW60 processor. To set up and run the included demo program, please refer to the Quick Start guide supplied with the DEMO9S08AW60E. There is also a soft copy of the quick start guide on the included resource CD.

1.2 System Requirements

An IBM PC or compatible running Windows® 98, Windows 2000, Windows NT® (version 4.0), or Windows® XP with at least 32MB of RAM an RS-232 serial port, and a USB port.

1.3 DEMO9S08AW60E Layout

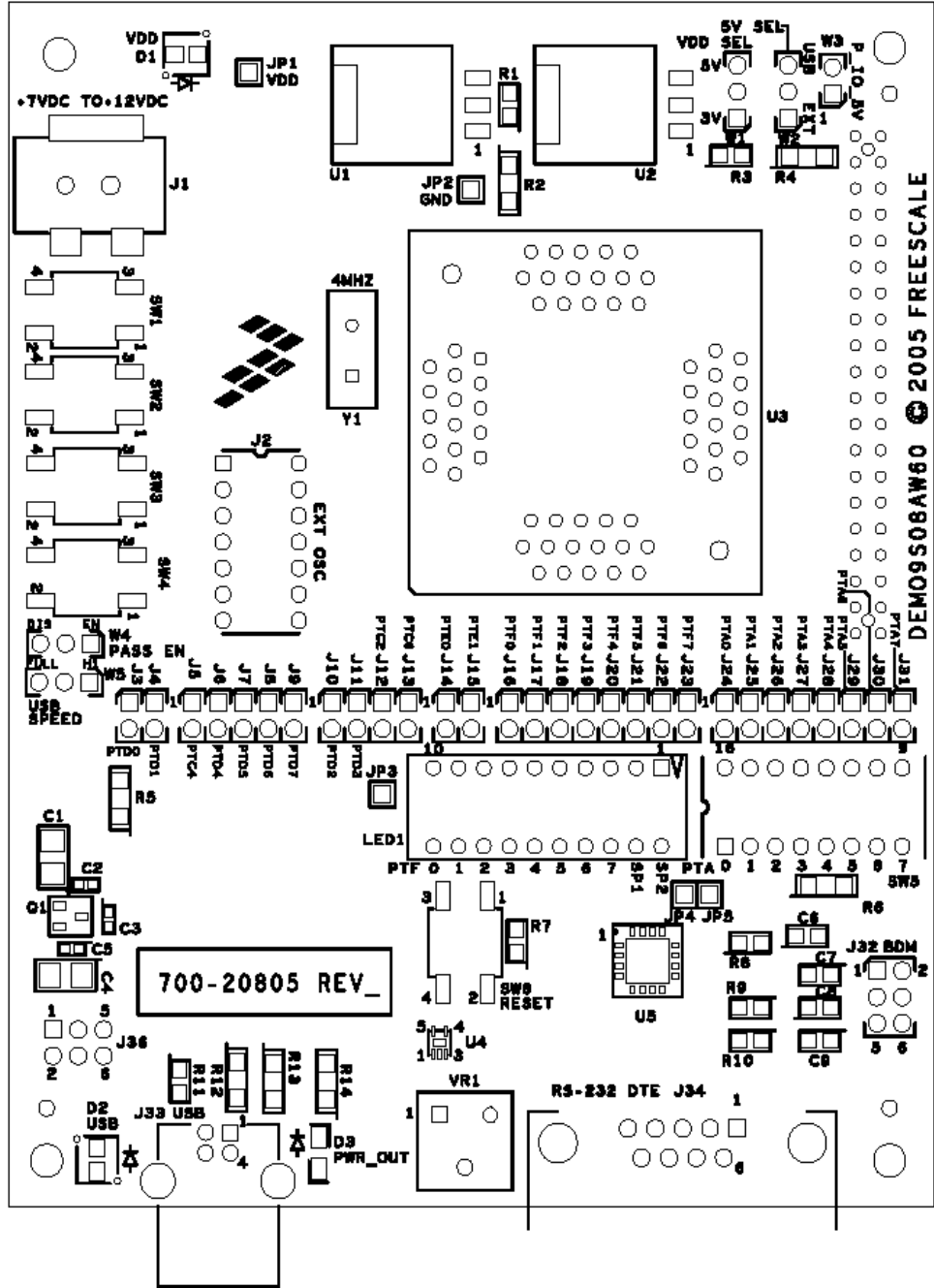

Figure 1-1 DEMO9S08AW60E Top Side

1.4 Features

- MC9S08AW60 CPU
 - 20 MHz Internal Bus Frequency
 - 60 Kbytes of on-chip in-circuit programmable FLASH
 - 2 Kbytes of on-chip RAM
 - 16-channel, 10-bit analog-to-digital converter
 - Two SCI modules
 - SPI module
 - 8-pin keyboard interrupt (KBI) module
 - 54 general-purpose input/output (I/O) pins
- Socketed 64 pin LQFP package
- Power and communication through the integrated USB-BDM cable
- External power jack for optional DC power supply (+7 to +12 VDC)
- 40 Pin expansion connector
- Four push-button user switches
- Ten LED light bar with 8 connected to I/O port (2 user assignable)
- Eight port rocker switch connected to I/O port
- All I/O pins can be disconnected from demo board for alternate use
- Master reset switch
- Freescale MMA6260Q Accelerometer
- On-board visible light sensor
- Potentiometer connected to the ADC
- On-board RS-232 serial port
- 4.5" x 3.5" board size

1.5 References

The following reference documents are included on the enclosed documentation CD:

- DEMO9S08AW60E_QS.pdf -- Quick Start Guide
- SPF-20805.pdf -- Schematic
- DEMO9S08AW60E_UG.pdf -- User's Guide (this document)

1.6 Getting Started

To get started quickly, please refer to the DEMO9S08AW60E Quick Start Guide. This guide will walk you through connecting your DEMO9S08AW60E to your PC, running a test program, and installing CodeWarrior Development Studio.

1.7 Memory Map

The table below shows the MC9S08AW60 memory map. Accessing reserved memory locations will produce unpredictable results. Accessing unimplemented locations will produce an illegal-address reset.

Table 1-1 MC9S08AW60 Memory Map

\$0000 - \$006F	Direct Page Registers	112 Bytes
\$0070 - \$086F	RAM	2048 Bytes
\$0870 - \$17FF	Flash	3984 Bytes
\$1800 - \$185F	High Page Registers	96 Bytes
\$1860 - \$FFFF	Flash	59,296 Bytes

1.8 Development Support

Application development and debug for the MC9S08AW60 is supported through the on-board USB - BDM interface (J33). There is also a 6 pin stand

alone BDM interface available (J32). This header is non-populated in the default configuration and can be installed by the user if needed.

1.8.1 Integrated BDM

The DEMO9S08AW60E features an integrated USB-BDM debugger from P&E Microcomputer Systems. All necessary signals are provided via the integrated debugger. A USB type B connector (J33) provides the connection between the DEMO9S08AW60E and your host PC.

The integrated debugger provides the DEMO9S08AW60E with power eliminating the need to power the board externally. Power is derived from the USB bus, therefore total current consumption should not exceed 500mA. Excessive current drain will violate the USB spec and damage to your Host PC's USB hub or the DEMO9S08AW60E could occur.

1.8.2 BDM Header

J32 is the stand alone BDM header. Use of this port requires the user to solder a 2 x 6 100 mil center header on the board. The pinout is as follows:

Table 1-2 BDM Connector (J32) Pinout

BKGD	1	2	GND
NC	3	4	RESET_B
NC	5	6	VDD

1.8.3 Socketed MCU

The MC9S08AW60 silicon is socketed on the DEMO9S08AW60E board. This socket is an open top, spring actuated, 0.8mm pitch socket. It is made by Wells Electronics, part number 7314-064-0-08. Before connecting power to the demo board the silicon should be installed in this socket. Using your thumb and index finger, press down on the socket until it is fully actuated. Place the silicon in the socket with a vacuum pen or other chip lifting device. Pin 1 of the silicon (denoted by an indented dot) should be in the bottom left hand corner, towards the USB connector J33. Release the socket. The MC9S08AW60 silicon should be centered within the socket and firmly held in place.

1.9 Power

The DEMO9S08AW60E allows the user to power the board in several different ways.

1.9.1 USB-BDM Interface

The default power option is to power the board through the integrated USB-BDM interface. To power the board in this manner, simply connect the supplied USB cable from the USB connector on the DEMO9S08AW60E (J33) to a USB port on your host computer. LED D1 will light green to let you know that power has been correctly applied to the board. When powering the board through the USB-BDM interface, jumpers W1, W2, and W3 should be in their default position as described below

Table 1-3 Jumper Settings in USB Power Mode

Jumper	Default Position	Setting	Description
W1	2-3	5V	Sets the board for 5V operation
W2	2-3	USB	Sets the board to be powered by through the USB
W3	1-2	P_IO_5V	Outputs 5V on pin 1 of the I/O connector, J35. This jumper should be removed if you do not want to output 5V on this pin.

1.9.2 External Power Jack

The DEMO9S08AW60E can also be powered externally through the barrel connector J1. This connector is a 2.1 mm, center positive connector. Voltage supplied through this connector should be between positive 7 volts and positive 12 volts DC. To power the board through the external power jack, jumper W2 should be moved to the 1-2, EXT position. LED D1 will light green to let you know that power has been correctly applied to the board. Jumper settings are detailed below

Table 1-4 Jumper Settings in EXT Power Mode

Jumper	Default Position	Setting	Description
W1	2-3	5V	Sets the board for 5V operation
W2	1-2	EXT	Sets the board to be powered externally through J1
W3	1-2	P_IO_5V	Outputs 5V on pin 1 of the I/O connector, J35. This jumper should be removed if you do not want to output 5V on this pin.

1.9.3 I/O Connector

The DEMO9S08AW60E can also be powered through pin 1 of the I/O connector J35. To power the board in this manner the jumper on W2 should be removed and positive 5V DC should be applied on pin 1 of J35. This voltage input is not regulated on the board so care should be taken to provide a clean 5V signal. LED D1 will light green to let you know that power has been correctly applied to the board. Jumper settings are detailed below

Table 1-5 Jumper Settings in I/O Connector Power Mode

Jumper	Default Position	Setting	Description
W1	2-3	5V	Sets the board for 5V operation
W2		Removed	Removes USB and EXT power options
W3	1-2	P_IO_5V	Inputs 5V on pin 1 of the I/O connector, J35

1.9.4 3 Volt Operation

The DEMO9S08AW60E can be run with VDD set to either 5 volts or 3 volts. To run the board at 3V when using any of the three power options, move jumper W1 to the 1-2, 3V position.

1.10 Reset Switch

The reset switch (SW6) provides a way to apply a reset to the MCU. The reset switch is connected directly to the RESET_B signal of the MCU. A 10K pull up resistor to VDD on the RESET_B signal allows for normal operation. When the reset switch is pressed the RESET_B signal is grounded and the MCU recognizes a reset.

1.11 Clock Source

An on-board 4MHz crystal (Y1) is connected between the XTAL and EXTAL pins of the MCU. There is also an option for the user to add a canned oscillator to the board. To add an oscillator, the zero ohm resistors R18 and R20 should be removed and an oscillator should be installed in the J2 footprint. This footprint accepts either 14 pin or 8 pin oscillators. To go back to the crystal option, the oscillator should be removed from J2 and zero ohm resistors should be reinstalled in the R18 and R20 footprints.

1.12 RS-232

An RS-232 translator provides RS-232 communication on com connector J34. This connector is a 9 pin Dsub right angle connector. TXD and RXD signals are routed from the MCU to the RS-232 transceiver.

Table 1-6 RS-232 Connections

MCU Port	Jumper	COM Signal	I/O Port Connector
PTE0/TXD1	J14	TXD OUT	J34-2
PTE1/RXD1	J15	RXD IN	J34-3

To disconnect port pins PTE0 and PTE1 from the RS-232 translator, remove jumpers J14 and J15. The full pinout of the COM connector (J34) is listed below

Table 1-7 COM Connector (J34) Pinout

Pin	Signal Name
1	Connected to pins 4 and 6 through zero ohm resistors R55 and R56
2	TXD
3	RXD
4	Connected to pins 1 and 6 through zero ohm resistors R55 and R56
5	GND
6	Connected to pins 1 and 4 through zero ohm resistors R55 and R56
7	NC
8	NC
9	NC

1.13 User Options

The DEMO9S08AW60E includes various user input and output devices to assist in application development and silicon evaluation. These devices include four pushbutton switches, a 10 LED light bar, 8 rocker switches, an accelerometer, a light sensor, and a potentiometer.

1.13.1 Pushbutton Switches

Four pushbutton switches provide momentary active low input for user applications. MCU port pins can be disconnected from these pushbutton

switches by removing the appropriate jumper. The table below describes the pushbutton switch connections

Table 1-8 Pushbutton Switch (SW1 - SW4) Connections

Switch	MCU Port	Jumper
SW1	PTC2	J12
SW2	PTC6	J13
SW3	PTD3	J11
SW4	PTD2	J10

1.13.2 Light Bar

A 10 red LED light bar (LED1) is provided to assist users during code development. The LEDs are active low and are illuminated when a logic low signal is driven from the MCU port pin. Eight of the LEDs on the light bar are connected to port F. The other two are spare and are user assignable. They are connected to test pads on the board that a user can solder to a desired port pin or other signal. Port F pins can be disconnected from the light bar by removing the appropriate jumper. The light bar is connected as described below

Table 1-9 Light Bar (LED1) Connections

LED	MCU Port	Jumper
LED0	PTF0	J16
LED1	PTF1	J17
LED2	PTF2	J18
LED3	PTF3	J19
LED4	PTF4	J20
LED5	PTF5	J21
LED6	PTF6	J22
LED7	PTF7	J23
LED8	NC	JP4
LED9	NC	JP5

1.13.3 Rocker Switches

Eight rocker switches (SW5) are provided for user application development. These switches are active low and input a logic low when set to the closed position. There are no external pullups on these switches so the internal pullups should be enabled on the MCU port pins to ensure proper operation. Port A pins can be disconnected from the rocker switches by removing the appropriate jumper. The rocker switches are connected as described below

Table 1-10 Rocker Switch (SW5) Connections

Switch	MCU Port	Jumper
1	PTA0	J24
2	PTA1	J25
3	PTA2	J26
4	PTA3	J27
5	PTA4	J28
6	PTA5	J29
7	PTA6	J30
8	PTA7	J31

1.13.4 Accelerometer

A Freescale MMA6260Q accelerometer (U5) is provided to assist users in developing accelerometer based application code. The MMA6260Q provides output data in the X and Y direction and has a self test mode. The MMA6260Q is a 3.3V part and is connected to the MC9S08AW60 through the use of a level translator. The X and Y outputs are connected back to the MCU both directly from the accelerometer (3.3V signals) and amplified to 5V through the use of op-amps. The self test is an active high input to the accelerometer. When a logic high is applied to the self test pin the center plate of the accelerometer is deflected, the resultant deflection is measured by the accelerometer's ASIC, and a proportional output voltage results. The MCU port pins can be disconnected from the accelerometer by removing the appropriate jumper. The accelerometer is connected as described below

Table 1-11 Accelerometer (U5) Connections

Accelerometer Function	MCU Port	Jumper
Self Test	PTC4	J5
Amplified Y Output	PTD4	J6
Amplified X Output	PTD5	J7
Raw Y Output	PTD6	J8
Raw X Output	PTD7	J9

1.13.5 Light Sensor

A photo detect IC (U4) combines a photodiode and a current amplifier on a single IC to provide variable current. The light sensor is connected to the MCU on PTD1. PTD1 can be disconnected from the light sensor by removing jumper J4.

1.13.6 Potentiometer

A 10 Kohm thumb-wheel potentiometer (VR1) provides variable resistor for users to assist them in application development. The potentiometer is connected to the MCU on PTD0. PTD0 can be disconnected from the potentiometer by removing jumper J3. The voltage seen on PTD0 is the result of a voltage divider that changes as the potentiometer is turned.

1.13.7 I/O Connector

A 40-pin I/O connector (J35) is available for user expansion. This connector is located on the bottom of the board and has holes so that pins of a connecting

board can pass through the top of the board. The I/O connector is pinned out as follows:

Table 1-12 I/O Connector (J35) Pinout

P_IO_5V	1	2	IRQ
GND	3	4	RESET_B
PTE0	5	6	BKGD
PTE1	7	8	PTG4
PTG0	9	10	PTB0
PTG1	11	12	PTB1
PTE2	13	14	PTB2
PTE3	15	16	PTB3
PTE6	17	18	PTB4
PTE5	19	20	PTB5
PTE7	21	22	PTB6
PTE4	23	24	PTB7
PTA0	25	26	PTC1
PTA1	27	28	PTC0
PTA2	29	30	PTG2
PTA3	31	32	PTG3
PTA4	33	34	PTF4
PTA5	35	36	PTF5
PTA6	37	38	PTC5
PTA7	39	40	PTC3

How to Reach Us:

USA/Europe/Locations not listed:

Freescale Semiconductor Literature Distribution
P.O. Box 5405, Denver, Colorado 80217
1-800-521-6274 or 480-768-2130

Japan:

Freescale Semiconductor Japan Ltd.
SPS, Technical Information Center
3-20-1, Minami-Azabu
Minato-ku
Tokyo 106-8573, Japan
81-3-3440-3569

Asia/Pacific:

Freescale Semiconductor H.K. Ltd.
2 Dai King Street
Tai Po Industrial Estate
Tai Po, N.T. Hong Kong
852-26668334

Learn More:

For more information about Freescale Semiconductor products, please visit
<http://www.freescale.com>

Information in this document is provided solely to enable system and software implementers to use Freescale Semiconductor products. There are no express or implied copyright licenses granted hereunder to design or fabricate any integrated circuits or integrated circuits based on the information in this document.

Freescale Semiconductor reserves the right to make changes without further notice to any products herein. Freescale Semiconductor makes no warranty, representation or guarantee regarding the suitability of its products for any particular purpose, nor does Freescale Semiconductor assume any liability arising out of the application or use of any product or circuit, and specifically disclaims any and all liability, including without limitation consequential or incidental damages. "Typical" parameters which may be provided in Freescale Semiconductor data sheets and/or specifications can and do vary in different applications and actual performance may vary over time. All operating parameters, including "Typicals" must be validated for each customer application by customer's technical experts. Freescale Semiconductor does not convey any license under its patent rights nor the rights of others. Freescale Semiconductor products are not designed, intended, or authorized for use as components in systems intended for surgical implant into the body, or other applications intended to support or sustain life, or for any other application in which the failure of the Freescale Semiconductor product could create a situation where personal injury or death may occur. Should Buyer purchase or use Freescale Semiconductor products for any such unintended or unauthorized application, Buyer shall indemnify and hold Freescale Semiconductor and its officers, employees, subsidiaries, affiliates, and distributors harmless against all claims, costs, damages, and expenses, and reasonable attorney fees arising out of, directly or indirectly, any claim of personal injury or death associated with such unintended or unauthorized use, even if such claim alleges that Freescale Semiconductor was negligent regarding the design or manufacture of the part.

Freescale™ and the Freescale logo are trademarks of Freescale Semiconductor, Inc. All other product or service names are the property of their respective owners.

© Freescale Semiconductor, Inc. 2004.

Looking for pricing, stock, or lifecycle information?

Click below to explore more details on WIN SOURCE:

- ⊖ [View DEMO9S08AW60E on WIN SOURCE](#)
- ⊖ [NXP / Nexperia Information](#)

Optimize Your Supply Chain with WIN SOURCE Solutions

- ✓ Global Sourcing Solution
- ✓ Obsolete Management
- ✓ Cost Control Management
- ✓ Shortage Management
- ✓ Alternative Solution
- ✓ Excess Inventory Management