



**THE DATASHEET OF
125932-HMC674LP3E**



FEATURES

- Equivalent input bandwidth: 9.3 GHz typical**
- Propagation delay: 85 ps typical**
- Overdrive and slew rate dispersion: 10 ps typical**
- Input signal minimum pulse width: 60 ps typical**
- Resistor programmable hysteresis**
- Differential latch control**
- Power dissipation: 140 mW typical**
- 16-terminal, 3 mm × 3 mm, ceramic leadless chip carrier (LCC)**
- 16-lead lead frame chip scale package (LFCSP)**

APPLICATIONS

- Automatic test equipment (ATE) applications**
- High speed instrumentation**
- Digital receiver systems**
- Pulse spectroscopy**
- High speed trigger circuits**
- Clock and data restoration**

GENERAL DESCRIPTION

The [HMC674LC3C/HMC674LP3E](#) are silicon germanium (SiGe), monolithic, ultrafast comparators that feature reduced swing positive emitter-coupled logic (RSPECL) output drivers and latch inputs. These comparators support 10 Gbps operation and provide 85 ps propagation delay and an input signal minimum pulse width of 60 ps with 0.2 ps rms of random jitter (RJ). Overdrive and slew rate dispersion is typically 10 ps, making the [HMC674LC3C/HMC674LP3E](#) ideal for a wide range of

applications from ATE to broadband communications. The RSPECL output stages directly drive 400 mV into a 50 Ω resistor terminated to $V_{TT} = (V_{CCO} - 2.0 \text{ V})$, where V_{TT} is the PECL termination voltage (see Figure 16). The [HMC674LC3C/HMC674LP3E](#) feature a high speed latch and programmable hysteresis. These devices can operate in either latch mode or as a tracking comparator.

FUNCTIONAL BLOCK DIAGRAM

HMC674LC3C/HMC674LP3E

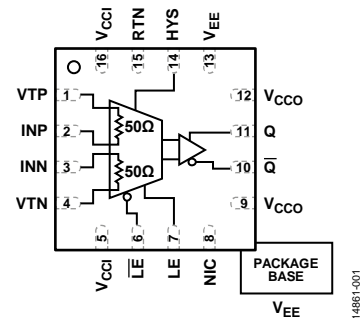

 Figure 1. [HMC674LC3C/HMC674LP3E](#) Functional Block Diagram

TABLE OF CONTENTS

Features	1	ESD Caution.....	6
Applications.....	1	Pin Configurations and Function Descriptions	7
Functional Block Diagram	1	Interface Schematics	8
General Description	1	Typical Performance Characteristics	9
Revision History	2	Theory of Operation	10
Specifications.....	3	Power Sequencing	10
Latch Enable (LE/ \overline{LE}) Specifications	3	Applications Information	11
DC Output Specifications	3	Evaluation Printed Circuit Board (PCB).....	11
AC Specifications.....	4	Application Circuits	12
Power Supply Specifications.....	4	Outline Dimensions	13
Timing Descriptions	5	Ordering Guide	13
Absolute Maximum Ratings.....	6		

REVISION HISTORY

Two Hittite Microwave product data sheets have been reformatted to the styles and standards of Analog Devices, Inc., and combined into one data sheet.

12/2016—v12.0616 (HMC674LC3C and HMC674LP3E) to Rev. K

Updated Format.....	Universal
Changes to Title, Features Section, and General Description Section.....	1
Changes to Table 7.....	6
Changes to Table 8.....	7
Changes to Figure 10.....	9
Changed Operational Description Section to Theory of Operation Section.....	10
Changes to Figure 15 and Table 9.....	12
Updated Outline Dimensions	13
Changes to Ordering Guide	13

SPECIFICATIONS

$T_A = 25^\circ\text{C}$, $V_{CCI} = 3.3\text{ V}$, $V_{CCO} = 2.0\text{ V}$, $V_{EE} = -3\text{ V}$, $V_{TT} = 0\text{ V}$, unless otherwise noted.

Table 1.

Parameter	Min	Typ	Max	Unit
INPUT				
Voltage Range	-2		+2	V
Differential Voltage	-1.75		+1.75	V
Offset Voltage (V_{OS})		± 5		mV
Temperature Coefficient		15		$\mu\text{V}/^\circ\text{C}$
Bias Current		15		μA
Temperature Coefficient		50		$\text{nA}/^\circ\text{C}$
Offset Current		4		μA
Impedance		50		Ω
Common-Mode		350		$\text{k}\Omega$
Differential		15		$\text{k}\Omega$
Active Gain		48		dB
Common-Mode Rejection Ratio (CMRR)		80		dB
Hysteresis, $R_{HYS} = \text{Infinity}$		± 1		mV

LATCH ENABLE ($\overline{\text{LE}}/\overline{\text{LE}}$) SPECIFICATIONS

Table 2.

Parameter	Symbol	Min	Typ	Max	Unit	Test Conditions/Comments
LATCH ENABLE ($\overline{\text{LE}}/\overline{\text{LE}}$)						
Input Impedance			8		$\text{k}\Omega$	Each pin
To Output Delay	t_{PLOL}, t_{PLOH}		85		ps	Input overdrive voltage (V_{OD}) = 200 mV
Minimum Pulse Width	t_{PL}		20		ps	$V_{OD} = 200\text{ mV}$
Input Range		1.6		2.4	V	$V_{OD} = 200\text{ mV}$
LATCH ENABLE ($\overline{\text{LE}}/\overline{\text{LE}}$) TIME						
Setup	t_S		45		ps	$V_{OD} = 200\text{ mV}$
Hold	t_H		-42		ps	

DC OUTPUT SPECIFICATIONS

$V_{CCO} = 2.00\text{ V}$, $V_{TT} = 0\text{ V}$, unless otherwise noted.

Table 3.

Parameter	Symbol	Min	Typ	Max	Unit
OUTPUT VOLTAGE					
High Level	V_{OH}	1.03	1.09	1.14	V
Low Level	V_{OL}	0.65	0.71	0.81	V
Differential Swing		440	760	980	mV p-p

AC SPECIFICATIONS

Table 4.

Parameter	Min	Typ	Max	Unit	Test Conditions/Comments
PROPAGATION DELAY (t_{PDL} , t_{PD} , t_{PDH})	80	85	110	ps	$V_{OD} = 500$ mV
Temperature Coefficient		0.45		ps/°C	
Skew (Rising to Falling Transition)		10		ps	$V_{OD} = 500$ mV
V_{OD} ¹ DISPERSION		10		ps	50 mV < V_{OD} < 1 V
PROPAGATION DELAY (t_{PD}) vs. INPUT COMMON-MODE VOLTAGE (V_{CM}) DISPERSION		8		ps	$V_{OD} = 500$ mV, -1.75 V < V_{CM} < $+1.75$ V
NOISE (RETURN TO INPUT, RTI)		5.9		nV/ $\sqrt{\text{Hz}}$	
EQUIVALENT INPUT BANDWIDTH (BW_{EQ}) ²	8.6	9.3	12	GHz	
JITTER					10 Gbps with ± 100 mV overdrive
Deterministic		2		ps p-p	
Random		0.2		ps rms	
INPUT SIGNAL MINIMUM PULSE WIDTH		60		ps	$V_{CM} = 0$ V, ± 100 mV overdrive
Q/Q TIME					From 20% to 80%
Rise		24		ps	
Fall		15		ps	

¹ V_{OD} is the input overdrive voltage, for example, ($V_{INP} - V_{INN} - V_{OS}$), where V_{OS} is the input offset voltage.

² Equivalent input bandwidth is calculated by

$$BW_{EQ} = 0.22 / \sqrt{(TRCOMP^2 - TRIN^2)}$$

where:

$TRIN$ is the 20%/80% transition time of a quasi Gaussian signal applied to the comparator input.

$TRCOMP$ is the effective transition time digitized by the comparator.

POWER SUPPLY SPECIFICATIONS

Table 5.

Parameter	Symbol	Min	Typ	Max	Unit
VOLTAGE					
Power Supply Voltage Input Stage	V_{CCI}	3.135	3.3	3.465	V
Power Supply Voltage Output Stage	V_{CCO}	1.8	3.3	3.465	V
Negative Power Supply (-3 V)	V_{EE}	-3.15	-3.0	-2.85	V
CURRENT					
Supply Input	I_{CCI}		9		mA
Supply Output	I_{CCO}		45		mA
V_{EE}	I_{EE}		19		mA
POWER DISSIPATION	P_D		140		mW
POWER SUPPLY REJECTION RATIO	PSRR				
V_{CCI}			38		dB
V_{EE}			38		dB

TIMING DESCRIPTIONS

Table 6.

Parameter	Symbol	Description
Input to Output High Delay	t_{PDH}	The propagation delay measured from the time the input signal crosses the reference (\pm the input offset voltage) to the 50% point of an output low to high transition.
Input to Output Low Delay	t_{PDL}	The propagation delay measured from the time the input signal crosses the reference (\pm the input offset voltage) to the 50% point of an output high to low transition.
Latch Enable (LE/ \overline{LE}) to Output High Delay	t_{PLOH}	The propagation delay measured from the 50% point of the latch enable (LE/ \overline{LE}) signal high to low transition to the 50% point of an output low to high transition.
Latch Enable (LE/ \overline{LE}) to Output Low Delay	t_{PLOL}	The propagation delay measured from the 50% point of the latch enable (LE/ \overline{LE}) signal high to low transition to the 50% point of an output high to low transition.
Minimum Hold Time	t_H	The minimum time after the positive transition of the latch enable (LE/ \overline{LE}) signal that the input signal must remain unchanged to be acquired and held at the outputs.
Minimum Latch Enable (LE/ \overline{LE}) Pulse Width	t_{PL}	The minimum time that the latch enable (LE/ \overline{LE}) signal must be low to acquire an input signal change.
Minimum Setup Time	t_S	The minimum time before the positive transition of the latch enable (LE/ \overline{LE}) signal that an input signal change must be present to be acquired and held at the outputs.
Output Rise Time	t_R	The amount of time required to transition from a low to a high output as measured at the 20% and 80% points.
Output Fall Time	t_F	The amount of time required to transition from a high to a low output as measured at the 20% and 80% points.
Input Overdrive Voltage	V_{OD}	The difference between the input voltages (V_{INP} and V_{INN}).

Timing Diagram

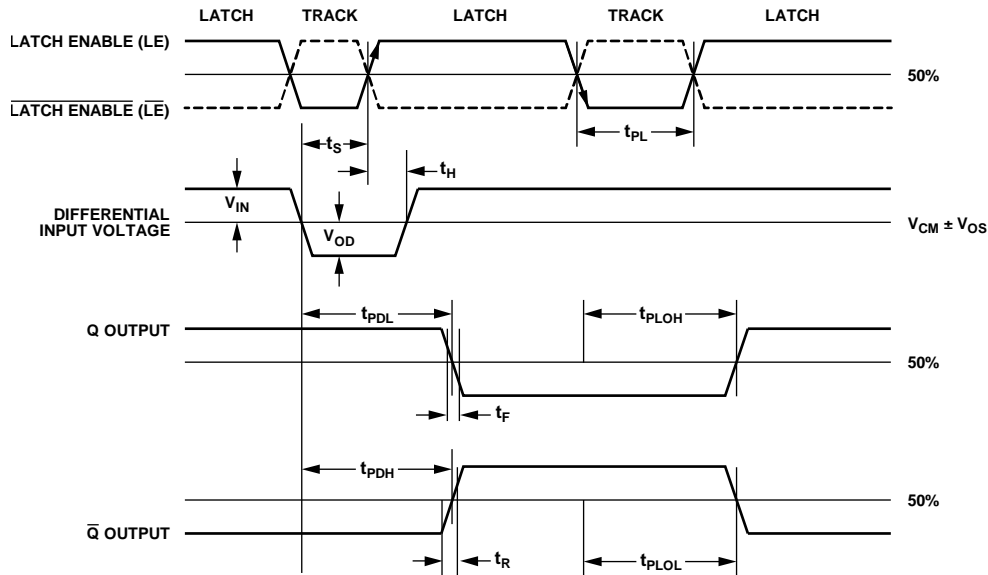

Figure 2. Timing Diagram

14881-002

ABSOLUTE MAXIMUM RATINGS

Table 7.

Parameter	Rating
Supply Voltage	
Input (V_{CCI} to GND)	-0.5 V to +4 V
Output (V_{CCO} to GND)	-0.5 V to +4 V
Positive Differential (V_{CCI} to V_{CCO})	-0.5 V to +3.3 V
V_{EE} Supply to GND	-3.3 V to +0.5 V
Input Voltage	
Differential	-2 V to +2 V
Latch Enable (LE/\overline{LE})	-0.5 V to $V_{CCI} + 0.5$ V
Applied Voltage (HYS)	V_{EE} to GND
Current	
Maximum Input	± 20 mA
Output	40 mA
Continuous Power Dissipation (P_{DISS} , $T_A = 85^\circ\text{C}$)	
Derate 43.5 mW/ $^\circ\text{C}$ Above 85°C (HMC674LP3E)	1.74 W
Derate 20.4 mW/ $^\circ\text{C}$ Above 85°C (HMC674LC3C)	0.816 W
Junction Temperature	125°C
Maximum Peak Reflow Temperature ¹	
MSL1 and MSL3	260°C
Thermal Resistance (θ_{JC})	
HMC674LP3E	23°C/W
HMC674LC3C	49°C/W
Storage Temperature Range	-65°C to $+150^\circ\text{C}$
Operating Temperature Range	-40°C to $+85^\circ\text{C}$
ESD Sensitivity, Human Body Model (HBM)	Class 1A

¹ See the Ordering Guide section.

Stresses at or above those listed under Absolute Maximum Ratings may cause permanent damage to the product. This is a stress rating only; functional operation of the product at these or any other conditions above those indicated in the operational section of this specification is not implied. Operation beyond the maximum operating conditions for extended periods may affect product reliability.

ESD CAUTION



ESD (electrostatic discharge) sensitive device.

Charged devices and circuit boards can discharge without detection. Although this product features patented or proprietary protection circuitry, damage may occur on devices subjected to high energy ESD. Therefore, proper ESD precautions should be taken to avoid performance degradation or loss of functionality.

PIN CONFIGURATIONS AND FUNCTION DESCRIPTIONS

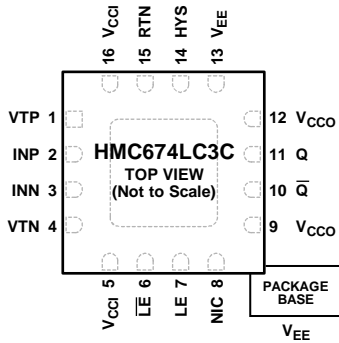

NOTES
 1. NIC = NOT INTERNALLY CONNECTED. CONNECT THIS PIN TO GROUND FOR IMPROVED NOISE.
 2. EXPOSED PAD. THE EXPOSED PAD MUST BE CONNECTED TO V_{EE}.

14861-003

Figure 3. HMC674LC3C Pin Configuration

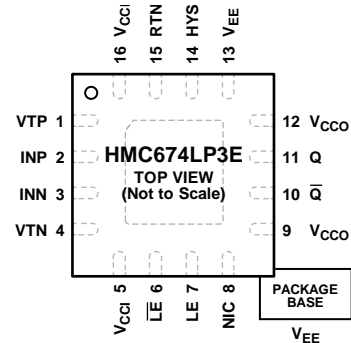

NOTES
 1. NIC = NOT INTERNALLY CONNECTED. CONNECT THIS PIN TO GROUND FOR IMPROVED NOISE.
 2. EXPOSED PAD. THE EXPOSED PAD MUST BE CONNECTED TO V_{EE}.

14861-004

Figure 4. HMC674LP3E Pin Configuration

Table 8. HMC674LC3C/HMC674LP3E Pin Function Descriptions

Pin No.	Mnemonic	Description
1	VTP	Termination Resistor Return Pin for V _P Input. See Figure 5 for the interface schematic.
2	INP	Noninverting Analog Input. See Figure 5 for the interface schematic.
3	INN	Inverting Analog Input. See Figure 5 for the interface schematic.
4	VTN	Termination Resistor Return Pin for V _N Input. See Figure 5 for the interface schematic.
5, 16	V _{CCI}	Positive Supply Voltage Input Stage. See Figure 6 for the interface schematic.
6	\overline{LE}	Latch Enable Input Pin, Inverting Side. See the Theory of Operation section for additional information. See Figure 6 for the interface schematic.
7	LE	Latch Enable Input Pin, Noninverting Side. See the Theory of Operation section for additional information. See Figure 6 for the interface schematic.
8	NIC	Not Internally Connected. Connect this pin to ground for improved noise.
9, 12	V _{CCO}	Positive Supply Voltage for the Output Stage. See Figure 7 for the interface schematic.
10	\overline{Q}	Inverting Output. \overline{Q} is at logic low if the analog voltage at the noninverting input, INP, is greater than the analog voltage at the inverting input, INN, provided that the comparator is in track mode. See the Theory of Operation section for additional information. See Figure 7 for the interface schematic.
11	Q	Noninverting Output. Q is at logic high if the analog voltage at the noninverting input, INP, is greater than the analog voltage at the inverting input, INN, provided that the comparator is in track mode. See the Theory of Operation section for additional information. See Figure 7 for the interface schematic.
13	V _{EE}	Negative Power Supply, -3 V. See Figure 6 for the interface schematic.
14	HYS	Hysteresis Control Pin. Leave this pin disconnected for zero hysteresis. Connect this pin to V _{EE} with a resistor to add the desired amount of hysteresis. See Figure 12 to determine the correct size of the R _{HYS} hysteresis control resistor. See Figure 8 for the interface schematic.
15	RTN	Return for ESD Protection.
	EPAD	Exposed Pad. The exposed pad must be connected to V _{EE} .

INTERFACE SCHEMATICS

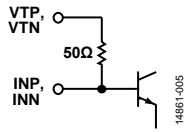

Figure 5. VTP, VTN and INP, INN Interface Schematic

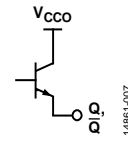

Figure 7. Q, \bar{Q} Interface Schematic

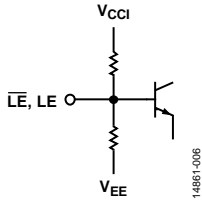

Figure 6. \bar{LE} , LE Interface Schematic

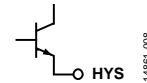

Figure 8. HYS Interface Schematic

TYPICAL PERFORMANCE CHARACTERISTICS

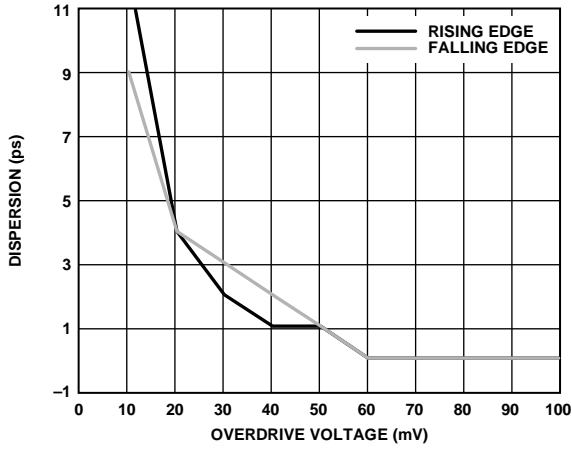

Figure 9. Dispersion vs. Overdrive Voltage

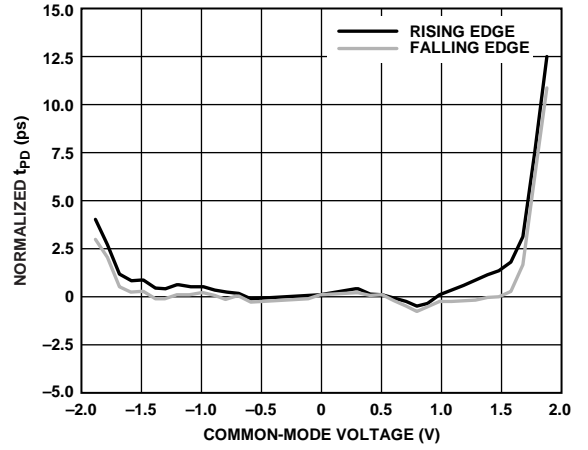

Figure 11. Normalized Propagation Delay (t_{PD}) vs. Common-Mode Voltage

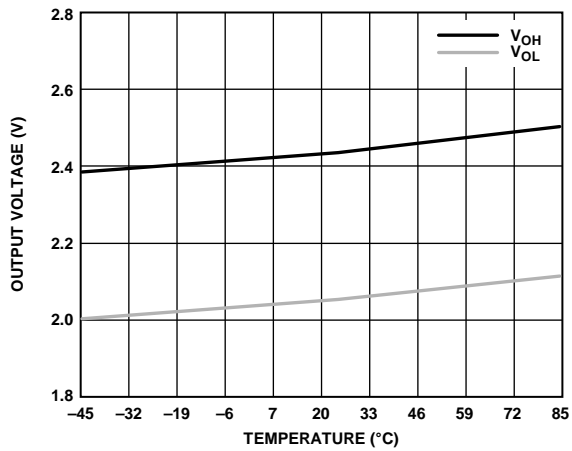

Figure 10. Output Voltage vs. Temperature

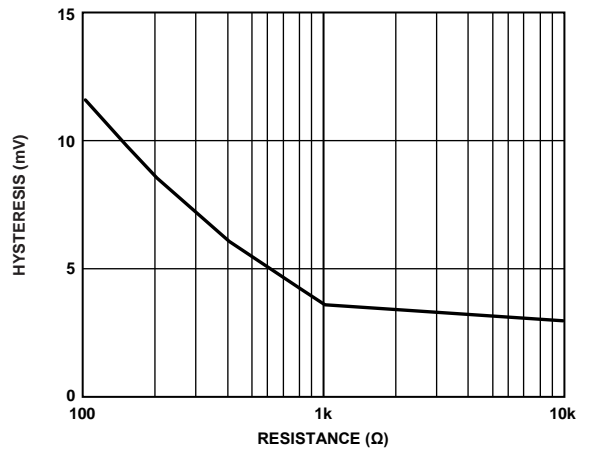

Figure 12. Comparator Hysteresis vs. R_{HYS} Control Resistance

THEORY OF OPERATION

The [HMC674LC3C/HMC674LP3E](#) are latched comparators with a 9.3 GHz equivalent input bandwidth. These devices are comprised of three blocks: an input amplifier, a latch, and an output buffer. The latching circuit is level sensitive and consists of a single, high speed latch. The [HMC674LC3C/HMC674LP3E](#) comparators support 10 Gbps operation. The input signal minimum pulse width is 60 ps.

The [HMC674LC3C/HMC674LP3E](#) operate in either track (transparent) mode, where the output follows the logical value of the input, or latch (hold) mode, where the output value is held to the logical value of the comparison result of the input just prior to $(LE - \overline{LE})$ going high. Select track mode operation by either setting $(LE - \overline{LE})$ low or by floating the LE and \overline{LE} inputs. Select latch mode by setting $(LE - \overline{LE})$ high. The input impedance of the LE and \overline{LE} inputs is 8 k Ω ; however, these inputs can be terminated with 50 Ω external resistors, if desired.

When the clock inputs are dc-coupled, they operate at an input common-mode voltage of 2 V. In this case, any termination resistors ideally return to 2 V. If the clock inputs are ac-coupled to the [HMC674LC3C/HMC674LP3E](#), return the input termination resistors to ground.

POWER SEQUENCING

As long as the input signal is not near the -2 V extreme, either V_{CC} or V_{EE} can be powered on first. However, if the input voltage is more negative than -1.8 V, use the following power-up sequence:

1. V_{EE}
2. V_{CCI} and V_{CCO} (if $V_{CCO} = V_{CCI}$)
3. V_{CCO} (if different than ground)

Note that the power-down sequence is the reverse of this sequence.

It is recommended to power up the [HMC674LC3C](#) or the [HMC674LP3E](#) before applying the input signal and to remove the input signal prior to powering either down. These recommendations are important if any of the inputs are more negative than -1.8 V.

APPLICATIONS INFORMATION

EVALUATION PRINTED CIRCUIT BOARD (PCB)

Figure 13 shows the front side of the evaluation PCB, and Figure 14 shows the back side of the evaluation PCB.

The evaluation PCB used in the application must use RF circuit design techniques. Signal lines must have 50 Ω impedance, and

the package ground leads must be connected directly to the ground plane similar to that shown in Figure 15. Use a sufficient number of via holes to connect the top and bottom ground planes to provide good RF grounding to 10 GHz. The evaluation PCB shown in Figure 13 is available from Analog Devices, Inc., upon request.

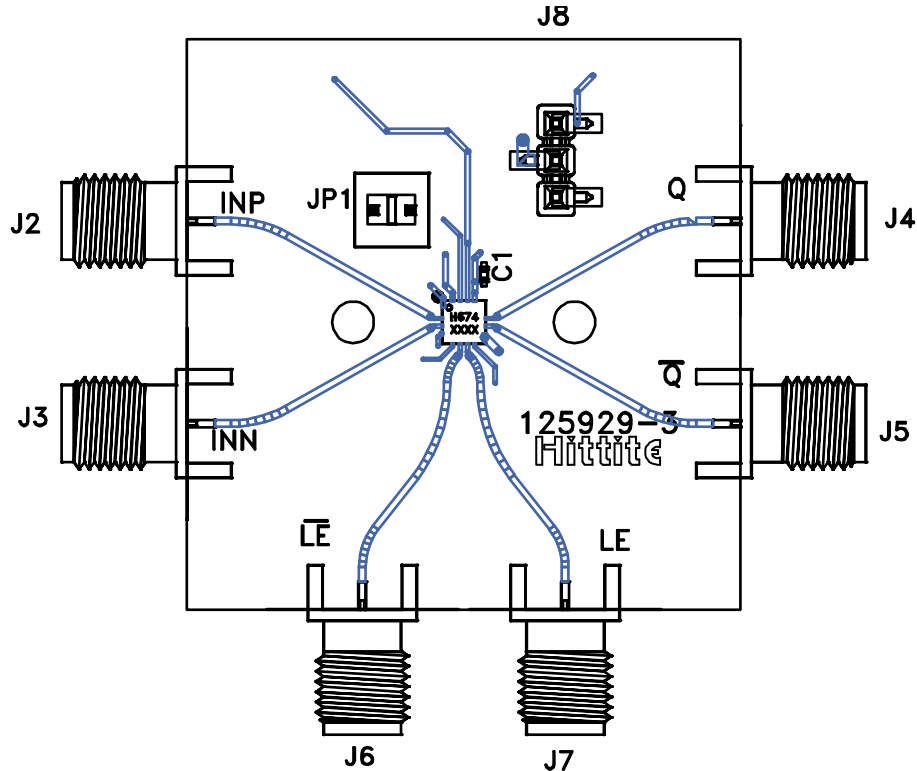

Figure 13. Front Side of the Evaluation PCB

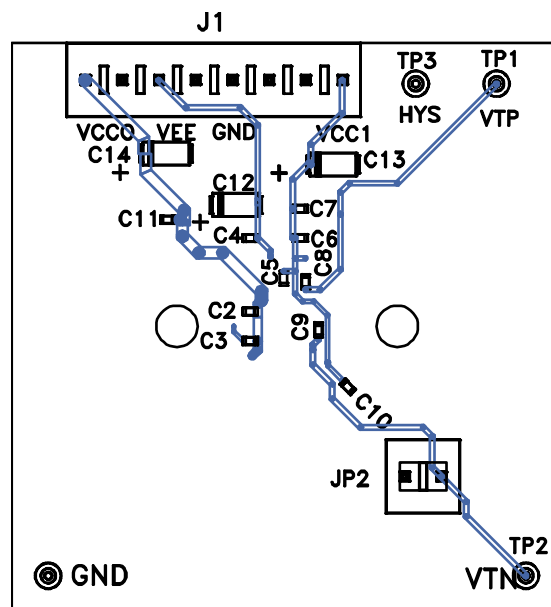

Figure 14. Back Side of the Evaluation PCB

14861-013

14861-014

OUTLINE DIMENSIONS

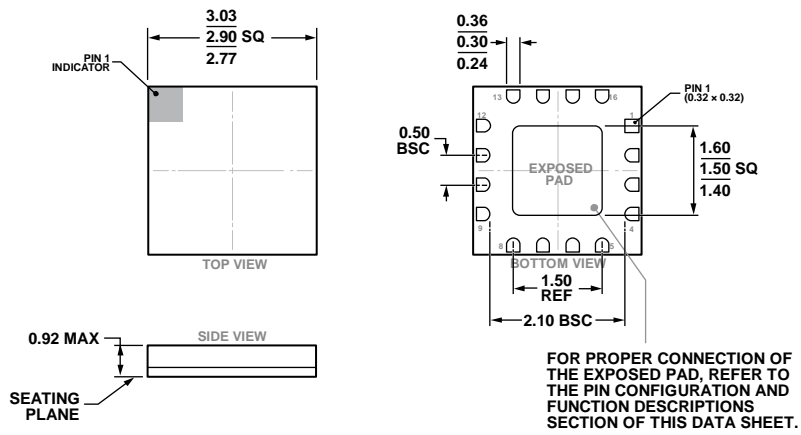
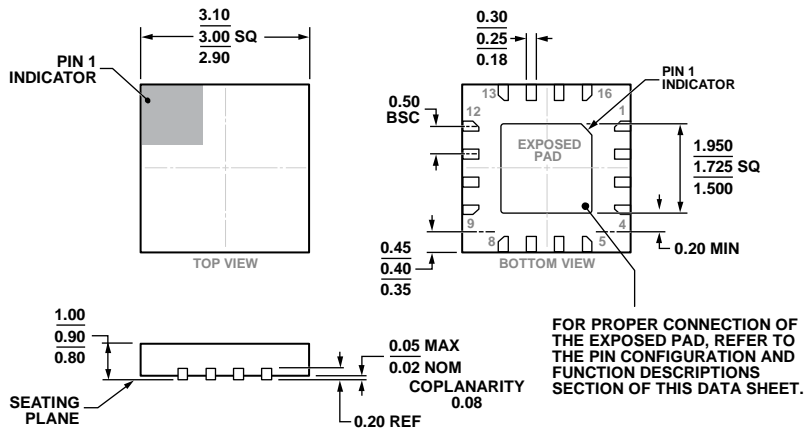

Figure 17. 16-Terminal Ceramic Leadless Chip Carrier [LCC] (E-16-1)
Dimensions shown in millimeters



COMPLIANT WITH JEDEC STANDARDS MO-220-VEED-4.

Figure 18. 16-Lead Lead Frame Chip Scale Package [LFCSP] 3 mm x 3 mm Body and 0.90 mm Package Height (HCP-16-1)
Dimensions shown in millimeters

ORDERING GUIDE

Model ¹	Temperature Range	Package Body Material	Lead Finish	MSL Rating ²	Package Description	Package Option	Branding
HMC674LC3C	-40°C to +85°C	Alumina, White	Gold over Nickel	MSL3	16-Terminal LCC	E-16-1	H674 XXXX
HMC674LC3CTR	-40°C to +85°C	Alumina, White	Gold over Nickel	MSL3	16-Terminal LCC	E-16-1	H674 XXXX
HMC674LC3CTR-R5	-40°C to +85°C	Alumina, White	Gold over Nickel	MSL3	16-Terminal LCC	E-16-1	H674 XXXX

Model ¹	Temperature Range	Package Body Material	Lead Finish	MSL Rating ²	Package Description	Package Option	Branding
HMC674LP3E	−40°C to +85°C	Low Stress, Injection Molded Plastic	100% Matte Sn	MSL1	16-Lead LFCSP	HCP-16-1	H674 XXXX
HMC674LP3ETR	−40°C to +85°C	Low Stress, Injection Molded Plastic	100% Matte Sn	MSL1	16-Lead LFCSP	HCP-16-1	H674 XXXX
125932-HMC674LC3C					HMC674LC3C Evaluation Board		
125932-HMC674LP3E					HMC674LP3E Evaluation Board		

¹ The HMC674LC3C, the HMC674LC3CTR, the HMC674LC3CTR-R5, the HMC674LP3E, and the HMC674LP3ETR are RoHS Compliant Parts.

² See the Absolute Maximum Ratings section.

Looking for pricing, stock, or lifecycle information?

Click below to explore more details on WIN SOURCE:

 [View 125932-HMC674LP3E on WIN SOURCE](#)

 [Analog Devices Inc. Information](#)

Optimize Your Supply Chain with WIN SOURCE Solutions

-  Global Sourcing Solution
-  Obsolete Management
-  Cost Control Management
-  Shortage Management
-  Alternative Solution
-  Excess Inventory Management