



**THE DATASHEET OF
MC33580BAPNAR2**



Quad High-Side Switch (Quad 15 mΩ)

The 33580 is one in a family of devices designed for low-voltage automotive and industrial lighting and motor control applications. Its four low $R_{DS(ON)}$ MOSFETs (four 15 mΩ) can control the high sides of four separate resistive or inductive loads.

Programming, control, and diagnostics are accomplished using a 16-bit SPI interface. Additionally, each output has its own parallel input for pulse-width modulation (PWM) control if desired. The 33580 allows the user to program via the SPI the fault current trip levels and duration of acceptable lamp inrush or motor stall intervals. Such programmability allows tight control of fault currents and can protect wiring harnesses and circuit boards as well as loads.

The 33580 is packaged in a power-enhanced 12x12 nonlead Power QFN package with exposed tabs.

Features

- Quad 15 mΩ High-Side Switches (at 25°C)
- Operating Voltage Range of 6.0 V to 27 V with Standby Current < 5.0 μA
- SPI Control of Overcurrent Limit, Overcurrent Fault Blanking Time, Output OFF Open Load Detection, Output ON/OFF Control, Watchdog Timeout, Slew Rates, and Fault Status Reporting
- SPI Status Reporting of Overcurrent, Open and Shorted Loads, Overtemperature, Undervoltage and Overvoltage Shutdown, Fail-Safe Pin Status, and Program Status
- Analog Current Feedback with Selectable Ratio
- Analog Board Temperature Feedback
- Enhanced -16 V Reverse Polarity V_{PWR} Protection
- Pb-Free Packaging Designated by Suffix Code PNA

33580

HIGH-SIDE SWITCH

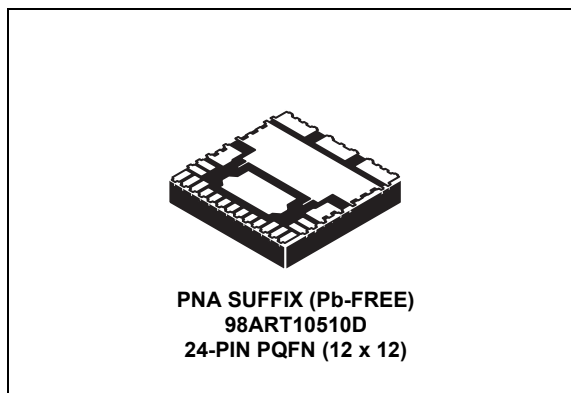

ORDERING INFORMATION		
Device	Temperature Range (T _A)	Package
MC33580BAPNA/R2	-40°C to 125°C	24 PQFN

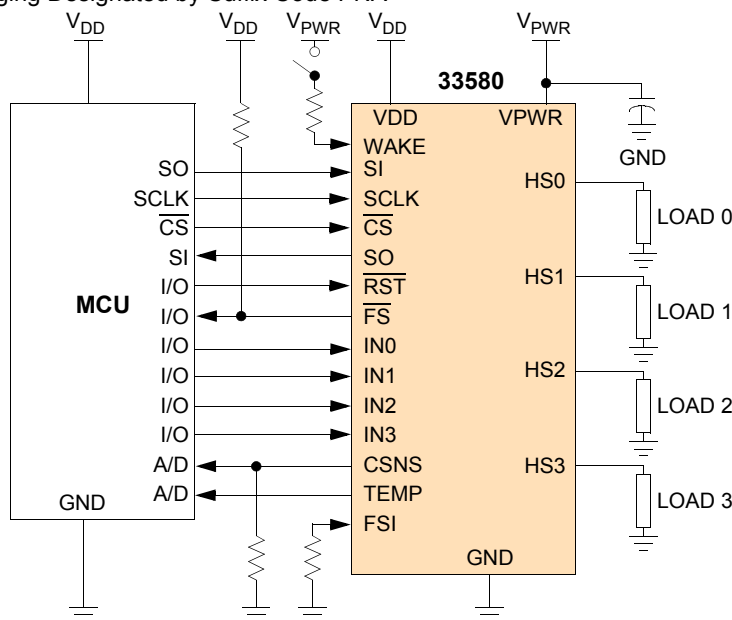

Figure 1. 33580 Simplified Application Diagram

* This document contains certain information on a new product. Specifications and information herein are subject to change without notice.

BLOCK DIAGRAM

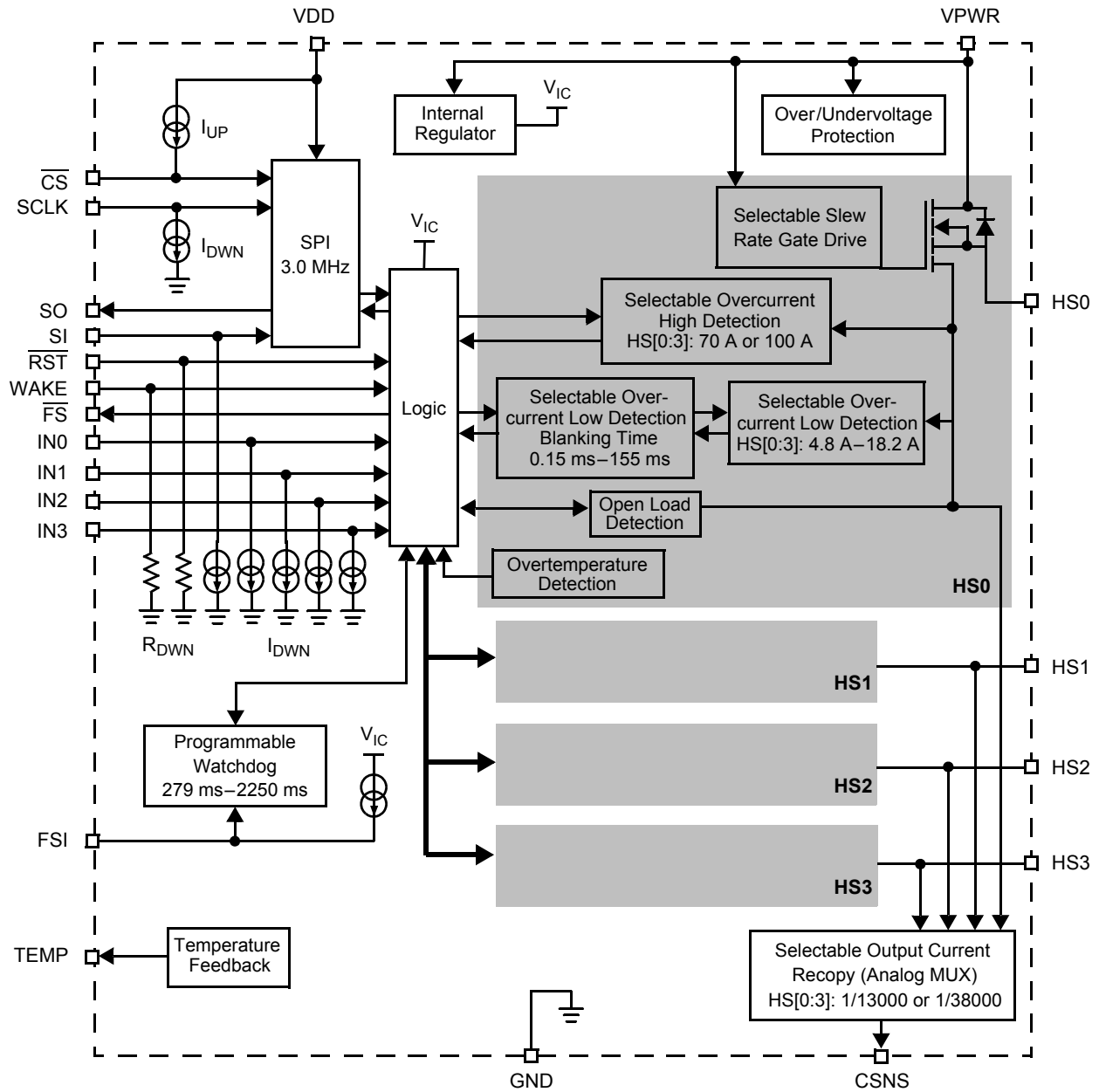

Figure 2. 33580 Simplified Internal Block Diagram

PIN CONNECTIONS

Transparent Top View of Package

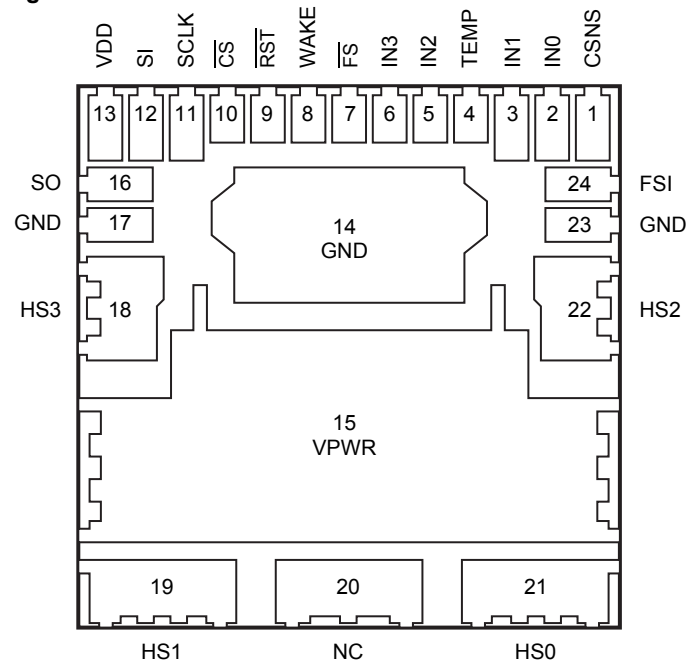

Figure 3. 33580 Pin Connections

Table 1. 33580 Pin Definitions

A functional description of each pin can be found in the Functional Pin Description section beginning on [page 16](#).

Pin Number	Pin Name	Pin Function	Formal Name	Definition
1	CSNS	Output	Output Current Monitoring	The Current Sense pin sources a current proportional to the designated HS0:HS3 output.
2 3 5 6	IN0 IN1 IN2 IN3	Input	Serial Inputs	The IN0:IN3 high-side input pins are used to directly control HS0:HS3 high-side output pins, respectively.
4	TEMP	Output	Temperature Feedback	This pin reports an analog value proportional to the temperature of the GND flag (pins 14, 17, 23). It is used by the MCU to monitor board temperature.
7	\overline{FS}	Output	Fault Status (Active Low)	This pin is an open drain configured output requiring an external pullup resistor to V_{DD} for fault reporting.
8	WAKE	Input	Wake	This input pin controls the device mode and watchdog timeout feature if enabled.
9	\overline{RST}	Input	Reset	This input pin is used to initialize the device configuration and fault registers, as well as place the device in a low-current sleep mode.
10	\overline{CS}	Input	Chip Select (Active Low)	This input pin is connected to a chip select output of a master microcontroller (MCU).
11	SCLK	Input	Serial Clock	This input pin is connected to the MCU providing the required bit shift clock for SPI communication.
12	SI	Input	Serial Input	This pin is a command data input pin connected to the SPI Serial Data Output of the MCU or to the SO pin of the previous device of a daisy-chain of devices.

Table 1. 33580 Pin Definitions (continued)

A functional description of each pin can be found in the Functional Pin Description section beginning on [page 16](#).

Pin Number	Pin Name	Pin Function	Formal Name	Definition
13	VDD	Power	Digital Drain Voltage (Power)	This pin is an external voltage input pin used to supply power to the SPI circuit.
14, 17, 23	GND	Ground	Ground	These pins are the ground for the logic and analog circuitry of the device.
15	VPWR	Power	Positive Power Supply	This pin connects to the positive power supply and is the source of operational power for the device.
16	SO	Output	Serial Output	This output pin is connected to the SPI Serial Data Input pin of the MCU or to the SI pin of the next device of a daisy-chain of devices.
18 19 21 22	HS3 HS1 HS0 HS2	Output	High-Side Outputs	Protected 15 mΩ high-side power output pins to the load.
20	NC	N/A	No Connect	This pin may not be connected.
24	FSI	Input	Fail-Safe Input	The value of the resistance connected between this pin and ground determines the state of the outputs after a Watchdog timeout occurs.

ELECTRICAL CHARACTERISTICS

MAXIMUM RATINGS

Table 2. Maximum Ratings

All voltages are with respect to ground unless otherwise noted. Exceeding these ratings may cause a malfunction or permanent damage to the device.

Ratings	Symbol	Value	Unit
ELECTRICAL RATINGS			
Operating Voltage Range Steady-State	$V_{PWR(SS)}$	-16 to 41	V
V_{DD} Supply Voltage	V_{DD}	-0.3 to 5.5	V
Input/Output Voltage ⁽¹⁾	See note ⁽¹⁾	-0.3 to 7.0	V
SO Output Voltage ⁽¹⁾	V_{SO}	-0.3 to $V_{DD}+0.3$	V
WAKE Input Clamp Current	$I_{CL(WAKE)}$	2.5	mA
CSNS Input Clamp Current	$I_{CL(CSNS)}$	10	mA
HS [0:3] Voltage Positive Negative	V_{HS}	41 -16	V
Output Current ⁽²⁾	$I_{HS[0:3]}$	22.8	A
Output Clamp Energy ⁽³⁾	$E_{CL[0:3]}$	0.2	J
ESD Voltage ⁽⁴⁾ Human Body Model (HBM) Charge Device Model (CDM) Corner Pins (1, 13, 19, 21) All Other Pins (2-12, 14-18, 20, 22-24)	V_{ESD1} V_{ESD2}	±2000 ±750 ±500	V
THERMAL RATINGS			
Operating Temperature Ambient Junction	T_A T_J	-40 to 125 -40 to 150	°C
Storage Temperature	T_{STG}	-55 to 150	°C
Thermal Resistance ⁽⁵⁾ Junction to Case Junction to Ambient	$R_{\theta JC}$ $R_{\theta JA}$	<1.0 30	°C/W
Peak Pin Reflow Temperature During Solder Mounting ⁽⁶⁾	T_{SOLDER}	245	°C

Notes

- Exceeding voltage limits on IN[0:3], \overline{RST} , FSI, CSNS, TEMP, SI, SO, SCLK, \overline{CS} , or \overline{FS} pins may cause a malfunction or permanent damage to the device.
- Continuous high-side output current rating so long as maximum junction temperature is not exceeded. Calculation of maximum output current using package thermal resistance is required.
- Active clamp energy using single-pulse method ($L = 2$ mH, $R_L = 0$ Ω , $V_{PWR} = 14$ V, $T_J = 150$ °C initial).
- ESD testing is performed in accordance with the Human Body Model (HBM) ($C_{ZAP} = 100$ pF, $R_{ZAP} = 1500$ Ω), the Machine Model (MM) ($C_{ZAP} = 200$ pF, $R_{ZAP} = 0$ Ω), and the Charge Device Model (CDM), Robotic ($C_{ZAP} = 4.0$ pF).
- Device mounted on a 2s2p test board per JEDEC JESD51-2.
- Pin soldering temperature limit is for 10 seconds maximum duration. Not designed for immersion soldering. Exceeding these limits may cause malfunction or permanent damage to the device.

STATIC ELECTRICAL CHARACTERISTICS

Table 3. Static Electrical Characteristics

Characteristics noted under conditions $6.0\text{ V} \leq V_{PWR} \leq 27\text{ V}$, $4.5\text{ V} \leq V_{DD} \leq 5.5\text{ V}$, $-40^\circ\text{C} \leq T_A \leq 125^\circ\text{C}$, $\text{GND} = 0\text{ V}$ unless otherwise noted. Typical values noted reflect the approximate parameter means at $T_A = 25^\circ\text{C}$ under nominal conditions unless otherwise noted.

Characteristic	Symbol	Min	Typ	Max	Unit
POWER INPUT (VPWR, VDD)					
Battery Supply Voltage Range Fully Operational	V_{PWR}	6.0	–	27	V
V_{PWR} Operating Supply Current Outputs ON, HS[0:3] open	$I_{PWR(ON)}$	–	–	20	mA
V_{PWR} Supply Current Outputs OFF, Open Load Detection Disabled, WAKE > 0.7 V_{DD} , $\overline{\text{RST}} = V_{\text{LOGIC HIGH}}$	$I_{PWR(SBY)}$	–	–	5.0	mA
Sleep State Supply Current ($V_{PWR} = 14\text{ V}$, $\overline{\text{RST}} < 0.5\text{ V}$, WAKE < 0.5 V) $T_A = 25^\circ\text{C}$ $T_A = 85^\circ\text{C}$	$I_{PWR(SLEEP)}$	– –	1.0 –	10 50	μA
V_{DD} Supply Voltage	$V_{DD(ON)}$	4.5	5.0	5.5	V
V_{DD} Supply Current No SPI Communication 3.0 MHz SPI Communication ⁽⁸⁾	$I_{DD(ON)}$	– –	– –	1.0 5.0	mA
V_{DD} Sleep State Current	$I_{DD(SLEEP)}$	–	–	5.0	μA
Overvoltage Shutdown Threshold	V_{OV}	28	32	36	V
Overvoltage Shutdown Hysteresis	V_{OVHYS}	0.2	0.8	1.5	V
Undervoltage Shutdown Threshold ⁽⁷⁾	V_{UV}	4.75	5.25	5.75	V
Undervoltage Hysteresis ⁽⁹⁾	V_{UVHYS}	–	0.25	–	V
Undervoltage Power-ON Reset	V_{UVPOR}	–	–	4.75	V

Notes

- The undervoltage fault condition is reported to SPI register as long as the external VDD supply is within specification and the VRWR voltage level does not go below the undervoltage Power-ON Reset threshold.
- Not guaranteed in production.
- This applies when the undervoltage fault is not latched (IN[0:3] = 0).

Table 3. Static Electrical Characteristics (continued)

Characteristics noted under conditions $6.0\text{ V} \leq V_{PWR} \leq 27\text{ V}$, $4.5\text{ V} \leq V_{DD} \leq 5.5\text{ V}$, $-40^\circ\text{C} \leq T_A \leq 125^\circ\text{C}$, $\text{GND} = 0\text{ V}$ unless otherwise noted. Typical values noted reflect the approximate parameter means at $T_A = 25^\circ\text{C}$ under nominal conditions unless otherwise noted.

Characteristic	Symbol	Min	Typ	Max	Unit
OUTPUTS (HS0, HS1, HS2, HS3)					
Output Drain-to-Source ON Resistance ($I_{HS} = 10\text{ A}$, $T_A = 25^\circ\text{C}$) $V_{PWR} = 6.0\text{ V}$ $V_{PWR} = 10\text{ V}$ $V_{PWR} = 13\text{ V}$	$R_{DS(ON)}$	–	–	23 15 15	$\text{m}\Omega$
Output Drain-to-Source ON Resistance ($I_{HS} = 10\text{ A}$, $T_A = 150^\circ\text{C}$) $V_{PWR} = 6.0\text{ V}$ $V_{PWR} = 10\text{ V}$ $V_{PWR} = 13\text{ V}$	$R_{DS(ON)}$	–	–	38 25.5 25.5	$\text{m}\Omega$
Output Source-to-Drain ON Resistance ⁽¹⁰⁾ $I_{HS} = 5.0\text{ A}$, $T_A = 25^\circ\text{C}$, $V_{PWR} = -12\text{ V}$	$R_{SD(ON)}$	–	–	30	$\text{m}\Omega$
Output Overcurrent High Detection Levels ($9.0\text{ V} \leq V_{PWR} \leq 16\text{ V}$) $\text{SOCH} = 0$ ⁽¹¹⁾ $\text{SOCH} = 1$	I_{OCH0} I_{OCH1}	80 56	100 70	120 84	A
Overcurrent Low Detection Levels ($9.0\text{ V} \leq V_{PWR} \leq 16\text{ V}$) $\text{SOCL}[2:0] : 000$ $\text{SOCL}[2:0] : 001$ $\text{SOCL}[2:0] : 010$ $\text{SOCL}[2:0] : 011$ $\text{SOCL}[2:0] : 100$ $\text{SOCL}[2:0] : 101$ $\text{SOCL}[2:0] : 110$ $\text{SOCL}[2:0] : 111$	I_{OCL0} I_{OCL1} I_{OCL2} I_{OCL3} I_{OCL4} I_{OCL5} I_{OCL6} I_{OCL7}	14.6 13 11.5 10 8.4 6.9 5.4 3.8	18.2 16.3 14.4 12.5 10.5 8.6 6.7 4.8	22.8 20.4 18 15.7 13.2 10.8 8.4 6.0	A
Current Sense Ratio ($9.0\text{ V} \leq V_{PWR} \leq 16\text{ V}$, $\text{CSNS} \leq 4.5\text{ V}$) $\text{DICR D2} = 0$ $\text{DICR D2} = 1$	C_{SR0} C_{SR1}	–	1/13000 1/38000	–	–
Current Sense Ratio (C_{SR0}) Accuracy Output Current 2.0 to 10 A	C_{SR0_ACC}	–15	–	15	%
Current Sense Ratio (C_{SR1}) Accuracy Output Current 10 A to 20 A	C_{SR1_ACC}	–19	–	19	%
Current Sense Clamp Voltage CSNS Open ; $I_{HS[0:3]} = 22\text{ A}$	$V_{CL(\text{CSNS})}$	4.5	6.0	7.0	V
Open Load Detection Current ⁽¹²⁾	I_{OLDC}	30	–	100	μA

Notes

- Source-Drain ON Resistance (Reverse Drain-to-Source ON Resistance) with negative polarity V_{PWR} .
- Guaranteed by process monitoring.
- Output OFF Open Load Detection Current is the current required to flow through the load for the purpose of detecting the existence of an open load condition when the specific output is commanded OFF.

Table 3. Static Electrical Characteristics (continued)

Characteristics noted under conditions $6.0\text{ V} \leq V_{PWR} \leq 27\text{ V}$, $4.5\text{ V} \leq V_{DD} \leq 5.5\text{ V}$, $-40^\circ\text{C} \leq T_A \leq 125^\circ\text{C}$, $\text{GND} = 0\text{ V}$ unless otherwise noted. Typical values noted reflect the approximate parameter means at $T_A = 25^\circ\text{C}$ under nominal conditions unless otherwise noted.

Characteristic	Symbol	Min	Typ	Max	Unit
OUTPUTS (HS0, HS1, HS2, HS3) (continued)					
Output Fault Detection Threshold Output Programmed OFF	$V_{\text{OFD(THRES)}}$	2.0	3.0	4.0	V
Output Negative Clamp Voltage $0.5\text{ A} \leq I_{\text{HS}[0:3]} \leq 2.0\text{ A}$, Output OFF	V_{CL}	-20	–	-16	V
Overtemperature Shutdown ⁽¹³⁾	T_{SD}	155	175	190	°C
Overtemperature Shutdown Hysteresis ⁽¹³⁾	$T_{\text{SD(HYS)}}$	5.0	–	20	°C
CONTROL INTERFACE (SCLK, SI, SO, IN[0:3], $\overline{\text{RST}}$, WAKE, $\overline{\text{FS}}$, $\overline{\text{CS}}$, FSI)					
Input Logic High Voltage ⁽¹⁴⁾	V_{IH}	$0.7 V_{\text{DD}}$	–	–	V
Input Logic Low Voltage ⁽¹⁴⁾	V_{IL}	–	–	$0.2 V_{\text{DD}}$	V
Input Logic Voltage Hysteresis ⁽¹⁵⁾	$V_{\text{IN(HYS)}}$	100	850	1200	mV
Input Logic Pulldown Current (SCLK, SI, IN[0:3], $V_{\text{IN}} > 0.2 V_{\text{DD}}$)	I_{DWN}	5.0	–	20	μA
$\overline{\text{RST}}$ Input Voltage Range	$V_{\overline{\text{RST}}}$	4.5	5.0	5.5	V
SO, $\overline{\text{FS}}$ Tri-State Capacitance ⁽¹⁵⁾	C_{SO}	–	–	20	pF
Input Logic Pulldown Resistor ($\overline{\text{RST}}$) and WAKE	R_{DWN}	100	200	400	kΩ
Input Capacitance ⁽¹⁵⁾	C_{IN}	–	4.0	12	pF
Wake Input Clamp Voltage ⁽¹⁶⁾ $I_{\text{CL(WAKE)}} < 2.5\text{ mA}$	$V_{\text{CL(WAKE)}}$	7.0	–	14	V
Wake Input Forward Voltage $I_{\text{CL(WAKE)}} = -2.5\text{ mA}$	$V_{\text{F(WAKE)}}$	-2.0	–	-0.3	V
SO High-State Output Voltage $I_{\text{OH}} = 1.0\text{ mA}$	V_{SOH}	$0.8 V_{\text{DD}}$	–	–	V
$\overline{\text{FS}}$, SO Low-State Output Voltage $I_{\text{OL}} = -1.6\text{ mA}$	V_{SOL}	–	0.2	0.4	V
SO Tri-State Leakage Current $\overline{\text{CS}} = 0.7V_{\text{DD}}$, $0 < V_{\text{SO}} < V_{\text{DD}}$	$I_{\text{SO(LEAK)}}$	-5.0	0	5.0	μA
Input Logic Pullup Current ($\overline{\text{CS}}$) ⁽¹⁷⁾ $V_{\text{in}} < 0.7 V_{\text{DD}}$	I_{UP}	5.0	–	20	μA

Notes

13. Guaranteed by process monitoring. Not production tested.
14. Upper and lower logic threshold voltage range applies to SI, $\overline{\text{CS}}$, SCLK, $\overline{\text{RST}}$, IN[0:3], and WAKE input signals. The WAKE and $\overline{\text{RST}}$ signals may be supplied by a derived voltage referenced to V_{PWR} .
15. Ads Input capacitance of SI, $\overline{\text{CS}}$, SCLK, $\overline{\text{RST}}$, and WAKE. This parameter is guaranteed by process monitoring but is not production tested.
16. The current must be limited by a series resistance when using voltages $> 7.0\text{ V}$.
17. Pullup current is with $\overline{\text{CS}}$ OPEN. $\overline{\text{CS}}$ has an active internal pullup to V_{DD} .

Table 3. Static Electrical Characteristics (continued)

Characteristics noted under conditions $6.0\text{ V} \leq V_{PWR} \leq 27\text{ V}$, $4.5\text{ V} \leq V_{DD} \leq 5.5\text{ V}$, $-40^\circ\text{C} \leq T_A \leq 125^\circ\text{C}$, $\text{GND} = 0\text{ V}$ unless otherwise noted. Typical values noted reflect the approximate parameter means at $T_A = 25^\circ\text{C}$ under nominal conditions unless otherwise noted.

Characteristic	Symbol	Min	Typ	Max	Unit
CONTROL INTERFACE (SCLK, SI, SO, IN[0:3], $\overline{\text{RST}}$, WAKE, $\overline{\text{FS}}$, $\overline{\text{CS}}$, FSI) (continued)					
FSI Input pin External Pulldown Resistance ⁽¹⁸⁾	RFS				kohms
FSI Disabled, HS[0:3] state according to direct inputs state and SPI INx_SPI bits and A/O_s bit		–	0	1.0	
FSI Enabled, HS[0:3] OFF		6.0	6.5	7.0	
FSI Enabled, HS0 ON, HS[1:3] OFF		15	17	19	
FSI Enabled, HS0 and HS2 ON, HS1 and HS3 OFF		40	Infinite	–	
Temperature Feedback $T_A = 25^\circ\text{C}$	T_{Feed}	3.8	3.9	4.0	V
Temperature Feedback Derating	DT_{Feed}	-7.2	-7.5	-7.8	mV/°C

Notes

- The selection of the RFS must take into consideration the tolerance, temperature coefficient and lifetime duration to assure that the resistance value will always be within the desired (specified) range.

DYNAMIC ELECTRICAL CHARACTERISTICS

Table 4. Dynamic Electrical Characteristics

Characteristics noted under conditions $6.0\text{ V} \leq V_{PWR} \leq 27\text{ V}$, $4.5\text{ V} \leq V_{DD} \leq 5.5\text{ V}$, $-40^\circ\text{C} \leq T_A \leq 125^\circ\text{C}$, $GND = 0\text{ V}$ unless otherwise noted. Typical values noted reflect the approximate parameter means at $T_A = 25^\circ\text{C}$ under nominal conditions unless otherwise noted.

Characteristic	Symbol	Min	Typ	Max	Unit
POWER OUTPUT TIMING (HS0, HS1, HS2, HS3)					
Output Rising Slow Slew Rate A (DICR D3 = 0) ⁽¹⁹⁾ 9.0 V < V _{PWR} < 16 V	SR _{RA_SLOW}	0.2	0.6	1.5	V/μs
Output Rising Slow Slew Rate B (DICR D3 = 0) ⁽²⁰⁾ 9.0 V < V _{PWR} < 16 V	SR _{RB_SLOW}	0.025	0.1	0.225	V/μs
Output Rising Fast Slew Rate A (DICR D3 = 1) ⁽¹⁹⁾ 9.0 V < V _{PWR} < 16 V	SR _{RA_FAST}	0.06	0.2	4.0	V/μs
Output Rising Fast Slew Rate B (DICR D3 = 1) ⁽²⁰⁾ 9.0 V < V _{PWR} < 16 V	SR _{RB_FAST}	0.025	0.3	1.1	V/μs
Output Falling Slow Slew Rate A (DICR D3 = 0) ⁽¹⁹⁾ 9.0 V < V _{PWR} < 16 V	SR _{FA_SLOW}	0.2	0.6	1.5	V/μs
Output Falling Slow Slew Rate B (DICR D3 = 0) ⁽²⁰⁾ 9.0 V < V _{PWR} < 16 V	SR _{FB_SLOW}	0.025	0.1	0.225	V/μs
Output Falling Fast Slew Rate A (DICR D3 = 1) ⁽¹⁹⁾ 9.0 V < V _{PWR} < 16 V	SR _{FA_FAST}	1.2	3.5	5.0	V/μs
Output Falling Fast Slew Rate B (DICR D3 = 1) ⁽²⁰⁾ 9.0 V < V _{PWR} < 16 V	SR _{FB_FAST}	0.025	0.7	1.1	V/μs
Direct Input Switching Frequency (DICR D3 = 0)	f _{PWM}	-	300	-	Hz

Notes

19. Rise and Fall Slew Rates A measured across a 5.0 Ω resistive load at high-side output = 0.5 V to V_{PWR}-3.5 V (see [Figure 4](#), page 13). These parameters are guaranteed by process monitoring.
20. Rise and Fall Slew Rates B measured across a 5.0 Ω resistive load at high-side output = 0.5 V to V_{PWR}-3.5 V (see [Figure 4](#)). These parameters are guaranteed by process monitoring.

Table 4. Dynamic Electrical Characteristics (continued)

Characteristics noted under conditions $6.0\text{ V} \leq V_{\text{PWR}} \leq 27\text{ V}$, $4.5\text{ V} \leq V_{\text{DD}} \leq 5.5\text{ V}$, $-40^\circ\text{C} \leq T_{\text{A}} \leq 125^\circ\text{C}$, $\text{GND} = 0\text{ V}$ unless otherwise noted. Typical values noted reflect the approximate parameter means at $T_{\text{A}} = 25^\circ\text{C}$ under nominal conditions unless otherwise noted.

Characteristic	Symbol	Min	Typ	Max	Unit
POWER OUTPUT TIMING (HS0, HS1, HS2, HS3) (continued)					
Output Turn-ON Delay Time in Slow Slew Rate ⁽²¹⁾ DICR = 0	$t_{\text{DLY_SLOW(ON)}}$	2.0	10	130	μs
Output Turn-ON Delay Time in Fast Slew Rate ⁽²¹⁾ DICR = 1	$t_{\text{DLY_FAST(ON)}}$	1.0	3.0	60	μs
Output Turn-OFF Delay Time in Slow Slew Rate Mode ⁽²²⁾ DICR = 0	$t_{\text{DLY_SLOW(OFF)}}$	20	100	400	μs
Output Turn-OFF Delay Time in Fast Slew Rate Mode ⁽²²⁾ DICR = 1	$t_{\text{DLY_FAST(OFF)}}$	5.0	20	100	μs
Overcurrent Low Detection Blanking Time OCLT[1:0] : 00 OCLT[1:0] : 01 ⁽²³⁾ OCLT[1:0] : 10 OCLT[1:0] : 11	t_{OCL0} t_{OCL1} t_{OCL2} t_{OCL3}	108 – 55 0.08	155 – 75 0.15	202 – 95 0.3	ms
Overcurrent High Detection Blanking Time	t_{OCH}	1.0	5	20	μs
$\overline{\text{CS}}$ to CSNS Valid Time ⁽²⁴⁾	t_{CNSVAL}	–	–	10	μs
Watchdog Timeout ⁽²⁵⁾ WD[1:0] : 00 WD[1:0] : 01 WD[1:0] : 10 WD[1:0] : 11	t_{WDTO0} t_{WDTO1} t_{WDTO2} t_{WDTO3}	446 223 1800 900	558 279 2250 1125	725 363 2925 1463	ms

Notes

- Turn-ON delay time measured from rising edge of any signal (IN[0:3], SCLK, $\overline{\text{CS}}$) that would turn the output ON to $V_{\text{HS}[0:3]} = 0.5\text{ V}$ with $R_{\text{L}} = 5.0\ \Omega$ resistive load.
- Turn-OFF delay time measured from falling edge of any signal (IN[0:3], SCLK, $\overline{\text{CS}}$) that would turn the output OFF to $V_{\text{HS}[0:3]} = V_{\text{PWR}} - 0.5\text{ V}$ with $R_{\text{L}} = 5.0\ \Omega$ resistive load.
- This logical bit is not defined. Do not use.
- Time necessary for the CSNS to be with $\pm 5\%$ of the targeted value.
- Watchdog timeout delay measured from the rising edge of WAKE or $\overline{\text{RST}}$ from a sleep state condition, to output turn-ON with the output driven OFF and FSI floating. The values shown are for WDR setting of [00]. The accuracy of t_{WDTO} is consistent for all configured watchdog time-outs.

Table 4. Dynamic Electrical Characteristics (continued)

Characteristics noted under conditions $6.0\text{ V} \leq V_{\text{PWR}} \leq 27\text{ V}$, $4.5\text{ V} \leq V_{\text{DD}} \leq 5.5\text{ V}$, $-40^\circ\text{C} \leq T_{\text{A}} \leq 125^\circ\text{C}$, $\text{GND} = 0\text{ V}$ unless otherwise noted. Typical values noted reflect the approximate parameter means at $T_{\text{A}} = 25^\circ\text{C}$ under nominal conditions unless otherwise noted.

Characteristic	Symbol	Min	Typ	Max	Unit
SPI INTERFACE CHARACTERISTICS					
Maximum Frequency of SPI Operation	f_{SPI}	–	–	3.0	MHz
Required Low State Duration for $\overline{\text{RST}}$ ⁽²⁶⁾	t_{WRST}	–	50	350	ns
Rising Edge of $\overline{\text{CS}}$ to Falling Edge of $\overline{\text{CS}}$ (Required Setup Time) ⁽²⁷⁾	$t_{\overline{\text{CS}}}$	–	–	300	ns
Rising Edge of $\overline{\text{RST}}$ to Falling Edge of $\overline{\text{CS}}$ (Required Setup Time) ⁽²⁷⁾	t_{ENBL}	–	–	5.0	μs
Falling Edge of $\overline{\text{CS}}$ to Rising Edge of SCLK (Required Setup Time) ⁽²⁷⁾	t_{LEAD}	–	50	167	ns
Required High State Duration of SCLK (Required Setup Time) ⁽²⁷⁾	t_{WSCLKh}	–	–	167	ns
Required Low State Duration of SCLK (Required Setup Time) ⁽²⁷⁾	t_{WSCLKl}	–	–	167	ns
Falling Edge of SCLK to Rising Edge of $\overline{\text{CS}}$ (Required Setup Time) ⁽²⁷⁾	t_{LAG}	–	50	167	ns
SI to Falling Edge of SCLK (Required Setup Time) ⁽²⁸⁾	$t_{\text{SI(SU)}}$	–	25	83	ns
Falling Edge of SCLK to SI (Required Setup Time) ⁽²⁸⁾	$t_{\text{SI(HOLD)}}$	–	25	83	ns
SO Rise Time $C_{\text{L}} = 200\text{ pF}$	t_{RSO}	–	25	50	ns
SO Fall Time $C_{\text{L}} = 200\text{ pF}$	t_{FSO}	–	25	50	ns
SI, $\overline{\text{CS}}$, SCLK, Incoming Signal Rise Time ⁽²⁸⁾	t_{RSI}	–	–	50	ns
SI, $\overline{\text{CS}}$, SCLK, Incoming Signal Fall Time ⁽²⁸⁾	t_{FSI}	–	–	50	ns
Time from Falling Edge of $\overline{\text{CS}}$ to SO Low Impedance ⁽²⁹⁾	$t_{\text{SO(EN)}}$	–	–	145	ns
Time from Rising Edge of $\overline{\text{CS}}$ to SO High Impedance ⁽³⁰⁾	$t_{\text{SO(DIS)}}$	–	65	145	ns
Time from Rising Edge of SCLK to SO Data Valid ⁽³¹⁾ $0.2\text{ V}_{\text{DD}} \leq \text{SO} \leq 0.8\text{ V}_{\text{DD}}$, $C_{\text{L}} = 200\text{ pF}$	t_{VALID}	–	65	105	ns

Notes

26. $\overline{\text{RST}}$ low duration measured with outputs enabled and going to OFF or disabled condition.
27. Maximum setup time required for the 33580 is the minimum guaranteed time needed from the microcontroller.
28. Rise and Fall time of incoming SI, $\overline{\text{CS}}$, and SCLK signals suggested for design consideration to prevent the occurrence of double pulsing.
29. Time required for output status data to be available for use at SO. 1.0 k Ω on pullup on $\overline{\text{CS}}$.
30. Time required for output status data to be terminated at SO. 1.0 k Ω on pullup on $\overline{\text{CS}}$.
31. Time required to obtain valid data out from SO following the rise of SCLK.

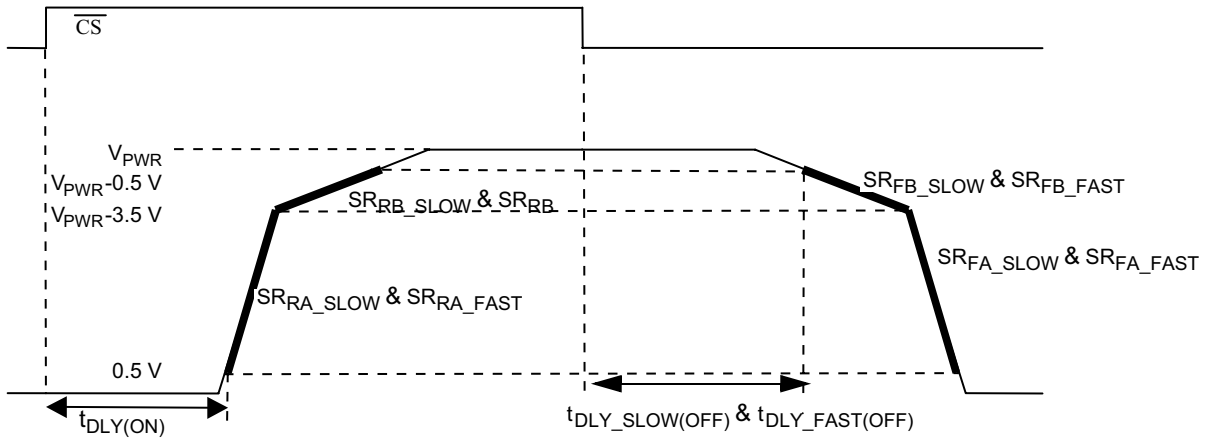
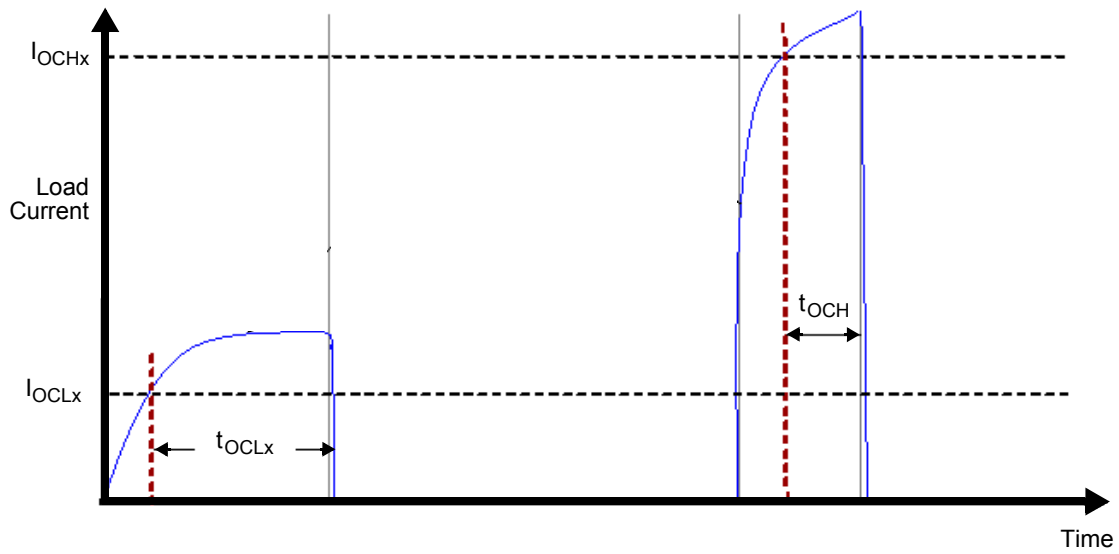
TIMING DIAGRAMS

Figure 4. Output Slew Rate and Time Delays

Figure 5. Overcurrent Shutdown

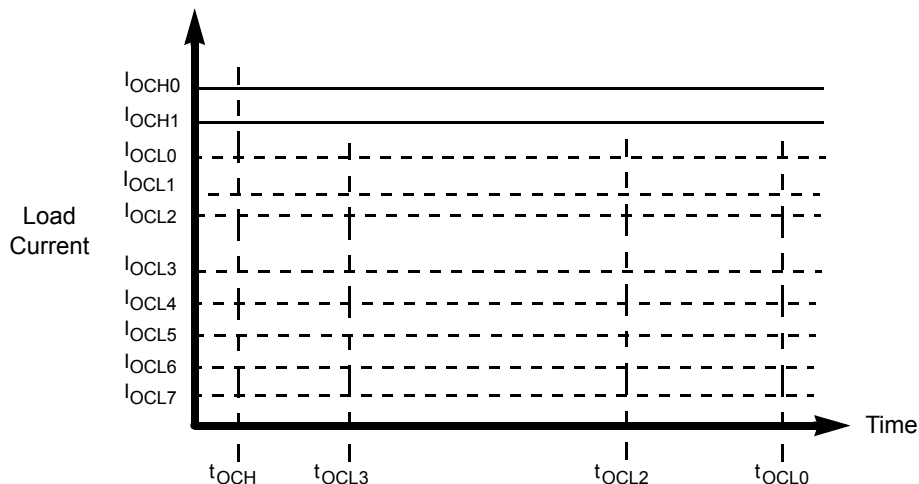

Figure 6. Overcurrent Low and High Detection

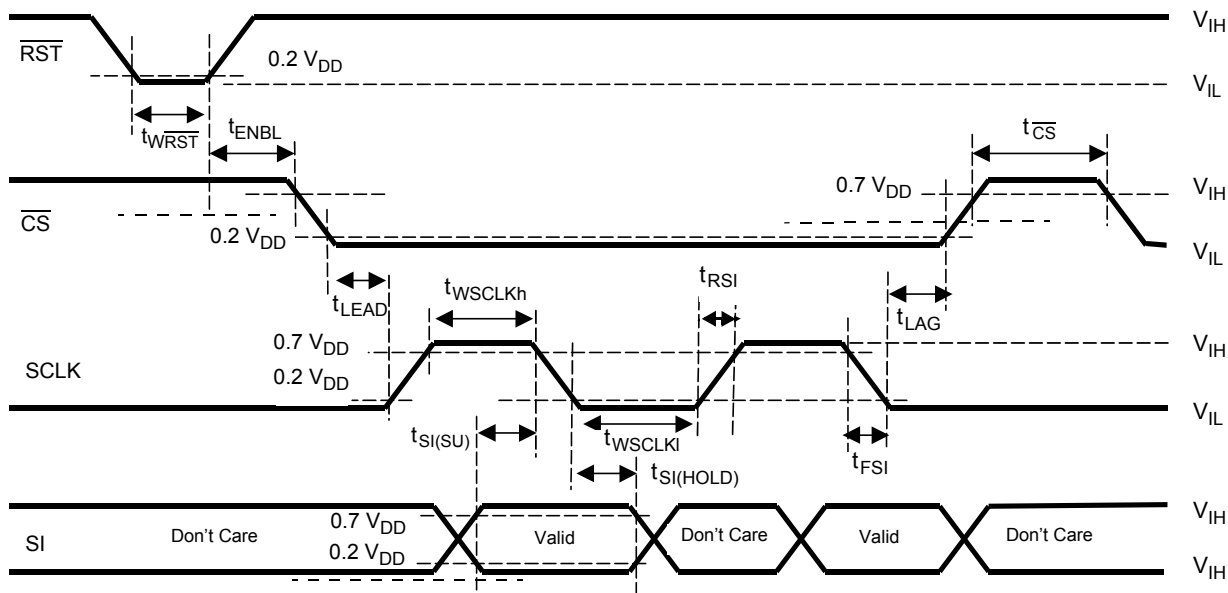

Figure 7. Input Timing Switching Characteristics

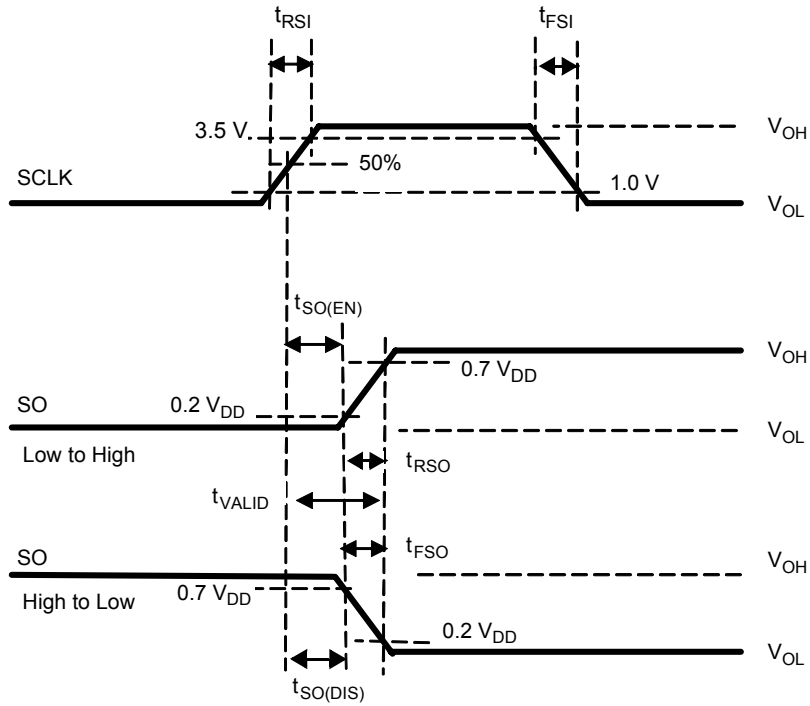

Figure 8. SCLK Waveform and Valid SO Data Delay Time

FUNCTIONAL DESCRIPTION

INTRODUCTION

The 33580 is one in a family of devices designed for low-voltage automotive and industrial lighting and motor control applications. Its four low $R_{DS(ON)}$ MOSFETs (15 m Ω) can control the high sides of four separate resistive or inductive loads.

Programming, control, and diagnostics are accomplished using a 16-bit SPI interface. Additionally, each output has its own parallel input for PWM control if desired. The 33580

allows the user to program via the SPI the fault current trip levels and duration of acceptable lamp inrush or motor stall intervals. Such programmability allows tight control of fault currents and can protect wiring harnesses and circuit boards as well as loads.

The 33580 is packaged in a power-enhanced 12 x 12 nonlead PQFN package with exposed tabs.

FUNCTIONAL PIN DESCRIPTION

OUTPUT CURRENT MONITORING (CSNS)

The Current Sense pin sources a current proportional to the designated HS0:HS3 output. That current is fed into a ground-referenced resistor and its voltage is monitored by an MCU's A/D. The output to be monitored is selected via the SPI. This pin can be tri-stated through SPI.

SERIAL INPUTS (IN0, IN1, IN2, IN3)

The IN0:IN3 high-side input pins are used to directly control HS0:HS3 high-side output pins, respectively. An SPI register determines if each input is activated or if the input logic state is ORed or ANDed with the SPI instruction. These pins are to be driven with 5.0 V CMOS levels, and they have an active internal pulldown current source.

TEMPERATURE FEEDBACK (TEMP)

This pin reports an analog voltage value proportional to the temperature of the GND. It is used by the MCU to monitor board temperature.

FAULT STATUS (\overline{FS})

This pin is an open drain configured output requiring an external pullup resistor to V_{DD} for fault reporting. If a device fault condition is detected, this pin is active LOW. Specific device diagnostic faults are reported via the SPI SO pin.

WAKE (WAKE)

This input pin controls the device mode and watchdog timeout feature if enabled. An internal clamp protects this pin from high damaging voltages when the output is current limited with an external resistor. This input has a passive internal pulldown.

RESET (\overline{RST})

This input pin is used to initialize the device configuration and fault registers, as well as place the device in a low-current sleep mode. The pin also starts the watchdog timer when transitioning from logic [0] to logic [1]. This pin should not be allowed to be logic [1] until V_{DD} is in regulation. This pin has a passive internal pulldown.

CHIP SELECT (\overline{CS})

The \overline{CS} pin enables communication with the master microcontroller (MCU). When this pin is in a logic [0] state, the device is capable of transferring information to, and receiving information from, the MCU. The 33580 latches in data from the Input Shift registers to the addressed registers on the rising edge of \overline{CS} . The device transfers status information from the power output to the Shift register on the falling edge of \overline{CS} . The SO output driver is enabled when \overline{CS} is logic [0]. \overline{CS} should transition from a logic [1] to a logic [0] state only when SCLK is a logic [0]. \overline{CS} has an active internal pullup, I_{UP} .

SERIAL CLOCK (SCLK)

The SCLK pin clocks the internal shift registers of the 33580 device. The serial input (SI) pin accepts data into the input shift register on the falling edge of the SCLK signal while the serial output (SO) pin shifts data information out of the SO line driver on the rising edge of the SCLK signal. It is important the SCLK pin be in a logic low state whenever \overline{CS} makes any transition. For this reason, it is recommended the SCLK pin be in a logic [0] whenever the device is not accessed (\overline{CS} logic [1] state). SCLK has an active internal pulldown. When \overline{CS} is logic [1], signals at the SCLK and SI pins are ignored and SO is tri-stated (high impedance) (see [Figure 9](#), page [18](#)).

SERIAL INPUT (SI)

This is a serial interface (SI) command data input pin. Each SI bit is read on the falling edge of SCLK. A 16-bit stream of serial data is required on the SI pin, starting with D15 to D0. The internal registers of the 33580 are configured and controlled using a 5-bit addressing scheme described in [Table 8](#), page [22](#). Register addressing and configuration are described in [Table 9](#), page [22](#). The SI input has an active internal pulldown, I_{DOWN} .

DIGITAL DRAIN VOLTAGE (VDD)

This pin is an external voltage input pin used to supply power to the SPI circuit. In the event V_{DD} is lost, an internal

supply provides power to a portion of the logic, ensuring limited functionality of the device.

GROUND (GND)

This pin is the ground for the device.

POSITIVE POWER SUPPLY (VPWR)

This pin connects to the positive power supply and is the source of operational power for the device. The V_{PWR} contact is the backside surface mount tab of the package.

SERIAL OUTPUT (SO)

The SO data pin is a tri-stateable output from the shift register. The SO pin remains in a high-impedance state until the \overline{CS} pin is put into a logic [0] state. The SO data is capable of reporting the status of the output, the device configuration, and the state of the key inputs. The SO pin changes state on

the rising edge of SCLK and reads out on the falling edge of SCLK. Fault and input status descriptions are provided in [Table 16](#), page [26](#).

HIGH-SIDE OUTPUTS (HS3, HS1, HS0, HS2)

Protected 15 m Ω high-side power output pins to the load.

FAIL-SAFE INPUT (FSI)

The value of the resistance connected between this pin and ground determines the state of the outputs after a Watchdog timeout occurs. Depending on the resistance value, either all outputs are OFF or the output HSO only is ON. If the FSI pin is left to float up to a logic [1] level, then the outputs HS0 and HS2 will turn ON when in the Fail-Safe state. When the FSI pin is connected to GND, the Watchdog circuit and Fail-Safe operation are disabled. This pin incorporates an active internal pullup current source.

FUNCTIONAL DEVICE OPERATION

SPI PROTOCOL DESCRIPTION

The SPI interface has a full duplex, three-wire synchronous data transfer with four I/O lines associated with it: Serial Input (SI), Serial Output (SO), Serial Clock (SCLK), and Chip Select (\overline{CS}).

The SI/SO pins of the 33580 follow a first-in first-out (D15 to D0) protocol, with both input and output words transferring the most significant bit (MSB) first. All inputs are compatible with 5.0 V CMOS logic levels.

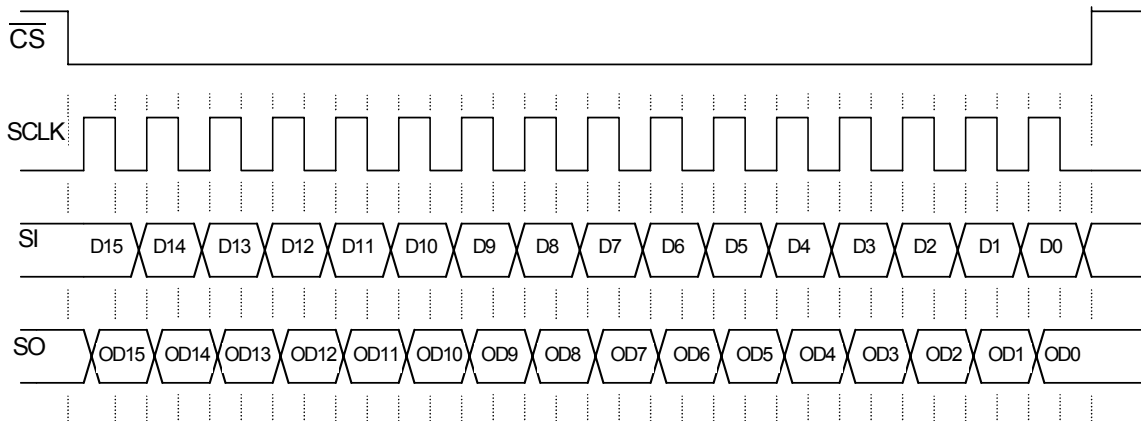

- Notes
1. \overline{RST} is a logic [1] state during the above operation.
 2. D15:D0 relate to the most recent ordered entry of data into the device.
 3. OD15:OD0 relate to the first 16 bits of ordered fault and status data out of the device.

Figure 9. Single 16-Bit Word SPI Communication

OPERATIONAL MODES

The 33580 has four operating modes: Sleep, Normal, Fault, and Fail-Safe. [Table 5](#) summarizes details contained in succeeding paragraphs.

Table 5. Fail-Safe Operation and Transitions to Other 33580 Modes

Mode	\overline{FS}	Wake	\overline{RST}	WDTO	Comments
Sleep	x	0	0	x	Device is in Sleep mode. All outputs are OFF
Normal	1	x	1	No	Normal mode. Watchdog is active if enabled.
Fault	0	1	1	No	Device is currently in fault mode. The faulted output(s) is (are) OFF.
	0	1	0		
	0	0	1		
Fail-Safe	1	0	1	Yes	Watchdog has timed out and the device is in Fail-Safe Mode. The outputs are as configured with the RFS resistor connected to FSI. \overline{RST} and WAKE must go from logic [1] to logic [0] simultaneously to bring the device out of the Fail-safe mode or momentarily tied the FSI pin to ground.
	1	1	1		
	1	1	0		

x = Don't care.

SLEEP MODE

The Default mode of the 33580 is the Sleep mode. This is the state of the device after first applying battery voltage (V_{PWR}) prior to any I/O transitions. This is also the state of the device when the WAKE and \overline{RST} are both logic [0]. In the Sleep mode, the output and all unused internal circuitry, such as the internal 5.0 V regulator, are off to minimize current draw. In addition, all SPI-configurable features of the device are as if set to logic [0]. The 33580 will transition to the Normal or Fail-Safe operating modes based on the WAKE and \overline{RST} inputs as defined in [Table 5](#).

NORMAL MODE

The 33580 is in Normal mode when:

- V_{PWR} and V_{DD} are within the normal voltage range.
- \overline{RST} pin is logic [1].
- No fault has occurred.

FAIL-SAFE MODE

Fail-Safe Mode and Watchdog

If the FSI input is not grounded, the watchdog timeout detection is active when either the WAKE or \overline{RST} input pin transitions from logic [0] to logic [1]. The WAKE input is capable of being pulled up to V_{PWR} with a series of limiting

resistance limiting the internal clamp current according to the specification.

The Watchdog timeout is a multiple of an internal oscillator and is specified in the [Table 15](#), page 24. As long as the WD bit (D15) of an incoming SPI message is toggled within the minimum watchdog timeout period (WDTO), based on the programmed value of the WDR, the device will operate normally. If an internal watchdog timeout occurs before the WD bit, the device will revert to a Fail-Safe mode until the device is reinitialized.

During the Fail-Safe mode, the outputs will be ON or OFF depending upon the resistor RFS connected to the FSI pin, regardless of the state of the various direct inputs and modes ([Table 6](#)).

Table 6. Output State During Fail-Safe Mode

RFS (kΩ)	High-Side State
0 (shorted to ground)	Fail-Safe Mode Disabled
6.0	All HS OFF
15	HS0 ON HS1:HS3 OFF
30 (open)	HS0 and HS2 ON HS1 and HS3 OFF

In the Fail-Safe mode, the SPI register content is retained except for overcurrent high and low detection levels, timing and latched overtemperature which are reset to their default value (SOCL, SOCH, OCTL and $\overline{OT_latch}_{[0:3]}$ bits). Then the watchdog, overvoltage, overtemperature, and overcurrent circuitry (with default value) are fully operational.

The Fail-Safe mode can be detected by monitoring the WDTO bit D2 of the WD register. This bit is logic [1] when the device is in Fail-Safe mode. The device can be brought out of

the Fail-Safe mode by transitioning the WAKE and \overline{RST} pins from logic [1] to logic [0] or forcing the FSI pin to logic [0]. [Table 5](#) summarizes the various methods for resetting the device from the latched Fail-Safe mode.

If the FSI pin is tied to GND, the Watchdog fail-safe operation is disabled.

Loss of V_{DD}

If the external 5.0 V supply is not within specification, or even disconnected, all register content is reset. The outputs can still be driven by the direct inputs IN0:IN3. The 33580 uses the battery input to power the output MOSFET-related current sense circuitry and any other internal logic providing fail-safe device operation with no V_{DD} supplied. In this state, the watchdog, undervoltage, overvoltage, overtemperature (latched), and overcurrent circuitry are fully operational with default values.

FAULT MODE

This 33580 indicates the faults below as they occur by driving the \overline{FS} pin to logic [0]:

- Overtemperature fault
- Overvoltage and undervoltage fault
- Open load fault
- Overcurrent fault (high and low)

The \overline{FS} pin will automatically return to logic [1] when the fault condition is removed, except for overcurrent, overtemperature (in case of latching configuration) and in some cases of undervoltage.

The \overline{FS} pin reports all faults. For latched faults, this pin is reset by a new Switch ON command (via SPI or direct input IN).

Fault information is retained in the fault register and is available (and reset) via the SO pin during the first valid SPI communication (refer to [Table 17](#), page 26).

PROTECTION AND DIAGNOSTIC FEATURES

OVERTEMPERATURE FAULT (LATCHING OR NON-LATCHING)

The 33580 incorporates overtemperature detection and shutdown circuitry for each output structure.

The overtemperature is latched per default and can be unlatched through SPI with $\overline{OT_latch}_{[0:3]}$ bits.

An overtemperature fault condition results in turning OFF the corresponding output. To remove the fault and be able to turn ON again the outputs, the failure must be removed and:

- in Normal Mode: the corresponding output must be commanded OFF and ON again in case of overtemperature latched ($\overline{OT_latch}$ bit = 0).

- in Normal Mode: the corresponding output turns ON automatically if the temperature is below $T_{SD}-T_{SD(HYS)}$ in case of unlatched overtemperature ($\overline{OT_latch}$ bit = 1).
- in Fail-Safe Mode: the FSI input must be grounded and then set to its nominal voltage to switch ON the outputs.

The overtemperature fault (one for each output) is reported by SPI. If the overtemperature is latched, the SPI reports $OTF_s = [1]$ and $OCLF_s = [1]$. In case of non-latched, $OTF_s = [1]$ only is reported.

The fault bits will be cleared in the status register after either a valid SPI read command or a power on reset of the device.

OVERCURRENT FAULT (LATCHING)

The 33580 has eight programmable overcurrent low detection levels (I_{OCL}) and two programmable overcurrent high detection levels (I_{OCH}) for maximum device protection. The two selectable, simultaneously active overcurrent detection levels, defined by I_{OCH} and I_{OCL} , are illustrated in [Figure 6](#), page 14. The eight different overcurrent low detect levels (I_{OCL0} : I_{OCL7}) are illustrated in [Figure 6](#).

If the load current level ever reaches the selected overcurrent low detection level and the overcurrent condition exceeds the programmed overcurrent time period (t_{OCX}), the device will latch the output OFF.

If at any time the current reaches the selected I_{OCH} level, then the device will immediately latch the fault and turn OFF the output, regardless of the selected t_{och} driver.

For both cases, the device output will stay off indefinitely until the device is commanded OFF and then ON again.

OVERVOLTAGE FAULT (NON-LATCHING)

The 33580 shuts down the output during an overvoltage fault (OVF) condition on the V_{PWR} pin. The output remains in the OFF state until the overvoltage condition is removed. When experiencing this fault, the OVF fault bit is set in the bit D1 and cleared after either a valid SPI read or a power reset of the device.

The overvoltage protection can be disabled through SPI (bit OV_DIS). When disabled, the returned SO bit OD13 still reflects any overvoltage condition (overvoltage warning).

UNDERVOLTAGE SHUTDOWN (LATCHING OR NON-LATCHING)

The output(s) will latch off at some battery voltage below 6.0 V. As long as the V_{DD} level stays within the normal specified range, the internal logic states within the device will be sustained.

In the case where battery voltage drops below the undervoltage threshold ($VPWRUV$) output will turn off, \overline{FS} will go to logic 0, and the fault register UVF bit will be set to 1.

Two cases need to be considered when the battery level recovers :

- If outputs command are low, \overline{FS} will go to logic 1 but the UVF bit will remain set to 1 until the next read operation (warning report).
- If the output command is ON, then \overline{FS} will remain at logic 0. The output must be turned OFF and ON again to re-enable the state of output and release \overline{FS} . The UVF bit will remain set to 1 until the next read operation.

The undervoltage protection can be disabled through SPI (bit $UV_dis = 1$). In this case, the \overline{FS} does not report any undervoltage fault condition, UVF bit is set to 1, and the output state is not changed as long as the battery voltage does not drop any lower than 2.5 V.

In case of V_{PWR} is missing, the daisy chain feature is available under V_{DD} in nominal conditions.

Table 7. Device Behavior in Case of Undervoltage

Quad High-Side Switch (VPWR Battery Voltage)**	State	UV Enable IN[0:3]=0 (Falling VPWR)	UV Enable IN[0:3]=0 (Falling or Rising VPWR)	UV Enable IN_x***=1 (Falling VPWR)	UV Enable IN_x***=1 (Rising VPWR)	UV Disable IN[0:3]=0 (Falling or Rising VPWR)	UV Disable IN_x***=1 (Falling or Rising VPWR)
VPWR > VPWRUV	Output State	OFF	OFF	ON	OFF	OFF	ON
	\overline{FS} State	1	1	1	0	1	1
	SPI Fault Register UVF Bit	0	1 until next read	0	1	0 (falling) 1 until next read (rising)	0 (falling) 1 until next read (rising)
VPWRUV > VPWR > UVPOR	Output State	OFF	OFF	OFF	OFF	OFF	ON
	\overline{FS} State	0	0	0	0	1	1
	SPI Fault Register UVF Bit	1	1	1	1	1	1
UVPOR > VPWR > 2.5 V*	Output State	OFF	OFF	OFF	OFF	OFF	ON
	\overline{FS} State	1	1	1	1	1	1
	SPI Fault Register UVF Bit	1 until next read	1	1 until next read	1 until next read	1 until next read	1 until next read
2.5 V > VPWR > 0V	Output State	OFF	OFF	OFF	OFF	OFF	OFF
	\overline{FS} State	1	1	1	1	1	1
	SPI Fault Register UVF Bit	1 until next read	1 until next read	1 until next read	1 until next read	1 until next read	1 until next read
	Comments	UV fault is not latched	UV fault is not latched		UV fault is latched		

* = Typical value; not guaranteed.

** = While V_{DD} remains within specified range.

*** = IN_x is equivalent to IN_x direct input or IN_spi_s SPI input.

OPEN LOAD FAULT (NON-LATCHING)

The 33580 incorporates open load detection circuitry on the output. Output open load fault (OLF) is detected and reported as a fault condition when the output is disabled (OFF). The open load fault is detected and latched into the status register after the internal gate voltage is pulled low enough to turn OFF the output. The OLF fault bit is set in the status register. If the open load fault is removed, the status register will be cleared after reading the register.

The open load protection can be disabled through SPI (bit OL_DIS). It is recommended to disable the open load detection circuitry in case of permanent disconnected load.

REVERSE BATTERY

The output survives the application of reverse voltage as low as -16 V. Under these conditions, the output's gate is enhanced to keep the junction temperature less than 150°C.

The ON resistance of the output is fairly similar to that in the Normal mode. No additional passive components are required except on V_{DD} .

GROUND DISCONNECT PROTECTION

In the event the 33580 ground is disconnected from load ground, the device protects itself and safely turns OFF the output regardless of the state of the output at the time of disconnection. A 10K resistor needs to be added between the wake pin and the rest of the circuitry in order to ensure that the device turns off in case of ground disconnect and to prevent this pin to exceed its maximum ratings.

Current limit resistors in the digital input lines protect the digital supply against excessive current (1 kohm typical).

LOGIC COMMANDS AND REGISTERS

SERIAL INPUT COMMUNICATION

SPI communication is accomplished using 16-bit messages. A message is transmitted by the MCU starting with the MSB, D15 and ending with the LSB, D0 ([Table 8](#)). Each incoming command message on the SI pin can be interpreted using the following bit assignments: the MSB, D15, is the watchdog bit. In some cases, output selection is done with bits D12:D11. The next three bits, D10:D8, are used to select the command register. The remaining five bits, D4:D0, are used to configure and control the outputs and their protection features.

Multiple messages can be transmitted in succession to accommodate those applications where daisy-chaining is desirable, or to confirm transmitted data, as long as the messages are all multiples of 16 bits. Any attempt made to latch in a message that is not 16 bits will be ignored.

The 33580 has defined registers, which are used to configure the device and to control the state of the outputs. [Table 9](#), page [22](#), summarizes the SI registers.

Table 8. SI Message Bit Assignment

Bit Sig	SI Msg Bit	Message Bit Description
MSB	D15	Watchdog in: toggled to satisfy watchdog requirements.
	D14:D15	Not used.
	D12:D11	Register address bits used in some cases for output selection.
	D10:D8	Register address bits.
	D7:D5	Not used.
	D4:D1	Used to configure the inputs, outputs, and the device protection features and SO status content.
LSB	D0	Used to configure the inputs, outputs, and the device protection features and SO status content.

Table 9. Serial Input Address and Configuration Bit Map

SI Register	SI Data															
	D15	D14	D13	D12	D11	D10	D9	D8	D7	D6	D5	D4	D3	D2	D1	D0
STATR_s	WDIN	0	0	0	0	0	0	0	0	0	0	SOA4	SOA3	SOA2	SOA1	SOA0
OCR0	WDIN	0	0	0	0	0	0	1	0	0	0	0	IN3_SPI	IN2_SPI	IN1_SPI	IN0_SPI
OCR1	WDIN	0	0	0	1	0	0	1	0	0	0	0	CSNS3_EN	CSNS2_EN	CSNS1_EN	CSNS0_EN
SOCHLR_s	WDIN	0	0	A ₁	A ₀	0	1	0	0	0	0	0	SOCH_s	SOCL2_s	SOCL1_s	SOCL0_s
CDTOLR_s	WDIN	0	0	A ₁	A ₀	0	1	1	0	0	0	0	OL_DIS_s	OCL_DIS_s	OCLT1_s	OCLT0_s
DICR_s	WDIN	0	0	A ₁	A ₀	1	0	0	0	0	0	0	FAST_SR_s	CSNS_high_s	DIR_DIS_s	A/O_s
UOVR	WDIN	0	0	0	0	1	0	1	0	0	0	0	$\overline{\text{OT_latch}}_1$	$\overline{\text{OT_latch}}_0$	UV_DIS	OV_DIS
WDR	WDIN	0	0	0	1	1	0	1	0	0	0	0	$\overline{\text{OT_latch}}_3$	$\overline{\text{OT_latch}}_2$	WD1	WD0
NAR	WDIN	0	0	0	0	1	1	0	0	0	0	0	No Action (Allow Toggling of D15-WDIN)			
RESET	0	0	0	X	X	X	X	X	0	0	0	0	0	0	0	0

x = Don't care.

s = Output selection with the bits A₁A₀ as defined in [Table 10](#).

D15 is used to toggle watchdog event (WDIN).

DEVICE REGISTER ADDRESSING

The following section describes the possible register addresses and their impact on device operation.

ADDRESS 00000—STATUS REGISTER (STATR_S)

The STATR register is used to read the device status and the various configuration register contents without disrupting the device operation or the register contents. The register bits D[4:0] determine the content of the first sixteen bits of SO data. In addition to the device status, this feature provides the ability to read the content of the OCR0, OCR1, SOCHLR, CDTOLR, DICR, UOVR, WDR, and NAR registers. (Refer to the section entitled [Serial Output Communication \(Device Status Return Data\)](#) beginning on page [25](#).)

ADDRESS 00001—OUTPUT CONTROL REGISTER (OCR0)

The OCR0 register allows the MCU to control the ON/OFF state of four outputs through the SPI. Incoming message bit D3:D0 reflects the desired states of the four high-side outputs (INx_SPI), respectively. A logic [1] enables the corresponding output switch and a logic [0] turns it OFF.

ADDRESS 01001—OUTPUT CONTROL REGISTER (OCR1)

Incoming message bits D3:D0 reflect the desired output that will be mirrored on the Current Sense (CSNS) pin. A logic [1] on message bits D3:D0 enables the CSNS pin for outputs HS3:HS0, respectively. In the event the current sense is enabled for multiple outputs, the current will be summed. In the event that bits D3:D0 are all logic [0], the output CSNS will be tri-stated. This is useful when several CSNS pins of several devices share the same A/D converter.

ADDRESS A₁A₀010—SELECT OVERCURRENT HIGH AND LOW REGISTER (SOCHLR_S)

The SOCHLR_s register allows the MCU to configure the output overcurrent low and high detection levels, respectively. Each output “s” is independently selected for configuration based on the state of the D12:D11 bits ([Table 10](#)).

Table 10. Output Selection

A ₁ (D12)	A ₀ (D11)	HS_s
0	0	HS0
0	1	HS1
1	0	HS2
1	1	HS3

Each output can be configured to different levels. In addition to protecting the device, this slow blow fuse emulation feature can be used to optimize the load requirements matching system characteristics. Bits D2:D0 set the overcurrent low detection level to one of eight possible levels, as shown in [Table 11](#), page [23](#). Bit D3 sets the overcurrent high detection level to one of two levels, as outlined in [Table 12](#), page [23](#).

Table 11. Overcurrent Low Detection Levels

SOCL2_s* (D2)	SOCL1_s* (D1)	SOCL0_s* (D0)	Overcurrent Low Detection (Amperes)
			HS0 to HS3
0	0	0	18.2
0	0	1	16.3
0	1	0	14.4
0	1	1	12.5
1	0	0	10.5
1	0	1	8.6
1	1	0	6.7
1	1	1	4.8

* “_s” refers to the output, which is selected through bits D12:D11; refer to [Table 10](#), page [23](#).

Table 12. Overcurrent High Detection Levels

SOCH_s* (D3)	Overcurrent High Detection (Amperes)
	HS0 to HS3
0	100
1	70

* “_s” refers to the output, which is selected through bits D12:D11; refer to [Table 10](#), page [23](#).

ADDRESS A₁A₀011—CURRENT DETECTION TIME AND OPEN LOAD REGISTER (CDTOLR)

The CDTOLR register is used by the MCU to determine the amount of time the device will allow an overcurrent low condition before an output latches OFF. Each output is independently selected for configuration based on A₁A₀, which are the state of the D12:D11 bits (refer to [Table 10](#), page [23](#)).

Bits D1:D0 (OCLT1_s:OCLT0_s) allow the MCU to select one of three overcurrent fault blanking times defined in [Table 13](#). Note that these time-outs apply only to the overcurrent low detection levels. If the selected overcurrent high level is reached, the device will latch off within 20 μ s.

Table 13. Overcurrent Low Detection Blanking Time

OCLT[1:0]_s*	Timing
00	155 ms
01	Do not use
10	75 ms
11	150 μ s

* “_s” refers to the output, which is selected through bits D12:D11.

A logic [1] on bit D2 (OCL_DIS_s) disables the overcurrent low detection feature. When disabled, there is no timeout for the selected output and the overcurrent low detection feature is disabled.

A logic [1] on bit D3 (OL_DIS_s) disables the open load (OL) detection feature for the output corresponding to the state of bits D12:D11.

ADDRESS A₁A₀100—DIRECT INPUT CONTROL REGISTER (DICR)

The DICR register is used by the MCU to enable, disable, or configure the direct IN pin control of each output. Each output is independently selected for configuration based on the state bits D12:D11 (refer to [Table 10](#), page 23).

For the selected output, a logic [0] on bit D1 (DIR_DIS_s) will enable the output for direct control. A logic [1] on bit D1 will disable the output from direct control.

While addressing this register, if the Input was enabled for direct control, a logic [1] for the D0 (A/O_s) bit will result in a Boolean AND of the IN pin with its corresponding IN_SPI D[4:0] message bit when addressing OCR0. Similarly, a logic [0] on the D0 pin results in a Boolean OR of the IN pin to the corresponding message bits when addressing the OCR0. This register is especially useful if several loads are required to be independently PWM controlled. For example, the IN pins of several devices can be configured to operate all of the outputs with one PWM output from the MCU. If each output is then configured to be Boolean ANDed to its respective IN pin, each output can be individually turned OFF by SPI while controlling all of the outputs, commanded on with the single PWM output.

A logic [1] on bit D2 (CSNS_high_s) is used to select the high ratio on the CSNS pin for the selected output. The default value [0] is used to select the low ratio ([Table 14](#)).

Table 14. Current Sense Ratio

CSNS_high_s* (D2)	Current Sense Ratio
	HS0 to HS3
0	1/13000
1	1/38000

* “_s” refers to the output, which is selected through bits D12:D11; refer to [Table 10](#), page 23.

A logic [1] on bit D3 (FAST_SR_s) is used to select the high speed slew rate for the selected output, the default value [0] corresponds to the low speed slew rate.

ADDRESS 00101—UNDERVOLTAGE/ OVERVOLTAGE AND HS[0,1] OVERTEMPERATURE REGISTER (UOVR)

The UOVR register disables the undervoltage (D1) and/or overvoltage (D0) protection. When these two bits are [0], the under- and overvoltage are active (default value).

The UOVR register allows the overtemperature detection latching on the HS0 and HS1. To latch the overtemperature, the bits (OT_latch_1 and OT_latch_0) must be set to [0] which is the default value. To disable the latching, both bits must be set to [1].

ADDRESS 01101—WATCHDOG AND HS[2,3] OVERTEMPERATURE REGISTER (WDR)

The WDR register is used by the MCU to configure the Watchdog timeout. The Watchdog timeout is configured using bits D1 and D0. When D1 and D0 bits are programmed for the desired watchdog timeout period ([Table 15](#)), the WDSPI bit should be toggled as well, ensuring the new timeout period is programmed at the beginning of a new count sequence.

The WDR register allows the overtemperature detection latching on the HS2 and HS3. To latch the overtemperature, the bits (OT_latch_3 and OT_latch_2) must be set to [0] which is the default value. To disable the latching, both bits must be set to [1].

Table 15. Watchdog Timeout

WD[1:0] (D1, D0)	Timing (ms)
00	558
01	279
10	2250
11	1125

ADDRESS 00110—NO ACTION REGISTER (NAR)

The NAR register can be used to no-operation fill SPI data packets in a daisy-chain SPI configuration. This would allow devices to be unaffected by commands being clocked over a daisy-chained SPI configuration. By toggling the WD bit (D15) the watchdog circuitry would continue to be reset while no programming or data read back functions are being requested from the device.

SERIAL OUTPUT COMMUNICATION (DEVICE STATUS RETURN DATA)

When the \overline{CS} pin is pulled low, the output register is loaded. Meanwhile, the data is clocked out MSB- (OD15-) first as the new message data is clocked into the SI pin. The first sixteen bits of data clocking out of the SO, and following a \overline{CS} transition, is dependent upon the previously written SPI word.

Any bits clocked out of the Serial Output (SO) pin after the first 16 bits will be representative of the initial message bits clocked into the SI pin since the \overline{CS} pin first transitioned to a logic [0]. This feature is useful for daisy-chaining devices as well as message verification.

A valid message length is determined following a \overline{CS} transition of [0] to [1]. If there is a valid message length, the data is latched into the appropriate registers. A valid message length is a multiple of 16 bits. At this time, the SO pin is tri-stated and the fault status register is now able to accept new fault status information.

SO data will represent information ranging from fault status to register contents, user selected by writing to the STATR bits OD4, OD3, OD2, OD1, and OD0. The value of the previous bits SOA4 and SOA3 will determine which output the SO information applies to for the registers which are output specific; viz., Fault, SOCHLR, CDTOLR, and DICR registers.

Note that the SO data will continue to reflect the information for each output (depending on the previous OD4, OD3 state) that was selected during the most recent STATR write until changed with an updated STATR write.

The output status register correctly reflects the status of the STATR-selected register data at the time that the \overline{CS} is pulled to a logic [0] during SPI communication, and/or for the period of time since the last valid SPI communication, with the following exceptions:

- The previous SPI communication was determined to be invalid. In this case, the status will be reported as though the invalid SPI communication never occurred.
- Battery transients below 6.0 V resulting in an under-voltage shutdown of the outputs may result in incorrect data loaded into the status register. The SO data transmitted to the MCU during the first SPI communication following an undervoltage V_{PWR} condition should be ignored.
- The \overline{RST} pin transition from a logic [0] to [1] while the WAKE pin is at logic [0] may result in incorrect data loaded into the Status register. The SO data transmitted to the MCU during the first SPI communication following this condition should be ignored.

SERIAL OUTPUT BIT ASSIGNMENT

The 16 bits of serial output data depend on the previous serial input message, as explained in the following paragraphs. [Table 16](#), page 26, summarizes SO returned data for bits OD15:OD0.

- Bit OD15 is the MSB; it reflects the state of the Watchdog bit from the previously clocked-in message.
- Bit OD14 remains logic [0] except when an undervoltage condition occurred.
- Bit OD13 remains logic [0] except when an overvoltage condition occurred.
- Bits OD12:OD8 reflect the state of the bits SOA4:SOA0 from the previously clocked in message.
- Bits OD7:OD4 give the fault status flag of the outputs HS3:HS0, respectively.
- The contents of bits OD3:OD0 depend on bits D4:D0 from the most recent STATR command SOA4:SOA0 as explained in the paragraphs following [Table 16](#).

Table 16. Serial Output Bit Map Description

	Previous STATR					SO Returned Data															
	SO A4	SO A3	SO A2	SO A1	SO A0	OD 15	OD 14	OD 13	OD 12	OD 11	OD 10	OD9	OD8	OD7	OD6	OD5	OD4	OD3	OD2	OD1	OD0
STATRs	A ₁	A ₀	0	0	0	WDIN	UVF	OVF	SOA4	SOA3	SOA2	SOA1	SOA0	ST3	ST2	ST1	ST0	OTF _s	OCHF _s	OCLF _s	OLF _s
OCR0	0	0	0	0	1	WDIN	UVF	OVF	SOA4	SOA3	SOA2	SOA1	SOA0	ST3	ST2	ST1	ST0	IN3_SPI	IN2_SPI	IN1_SPI	IN0_SPI
OCR1	0	1	0	0	1	WDIN	UVF	OVF	SOA4	SOA3	SOA2	SOA1	SOA0	ST3	ST2	ST1	ST0	CSNS3 $\overline{\text{EN}}$	CSNS2 $\overline{\text{EN}}$	CSNS1 $\overline{\text{EN}}$	CSNS0 $\overline{\text{EN}}$
SOCHL R _s	A ₁	A ₀	0	1	0	WDIN	UVF	OVF	SOA4	SOA3	SOA2	SOA1	SOA0	ST3	ST2	ST1	ST0	SOCH _s	SOCL2 _s	SOCL1 _s	SOCL0 _s
CDTOL R _s	A ₁	A ₀	0	1	1	WDIN	UVF	OVF	SOA4	SOA3	SOA2	SOA1	SOA0	ST3	ST2	ST1	ST0	OL_DIS _s	OCL_DIS _s	OCL1 _s	OCL0 _s
DICR _s	A ₁	A ₀	1	0	0	WDIN	UVF	OVF	SOA4	SOA3	SOA2	SOA1	SOA0	ST3	ST2	ST1	ST0	Fast_SR _s	CSNS_high _s	DIR_DIS _s	A/O _s
UOVR	0	0	1	0	1	WDIN	UVF	OVF	SOA4	SOA3	SOA2	SOA1	SOA0	ST3	ST2	ST1	ST0	$\overline{\text{OT_latch}}_1$	$\overline{\text{OT_latch}}_0$	UV_DIS	OV_DIS
WDR	0	1	1	0	1	WDIN	UVF	OVF	SOA4	SOA3	SOA2	SOA1	SOA0	ST3	ST2	ST1	ST0	0	WDTO	WD1	WD0
PINR0	0	0	1	1	0	WDIN	UVF	OVF	SOA4	SOA3	SOA2	SOA1	SOA0	ST3	ST2	ST1	ST0	HS2_failsafe	HS0_failsafe	WD_en	WAKE
PINR1	0	1	1	1	0	WDIN	UVF	OVF	SOA4	SOA3	SOA2	SOA1	SOA0	ST3	ST2	ST1	ST0	IN3	IN2	IN1	IN0
PINR2	0	1	1	1	1	WDIN	UVF	OVF	SOA4	SOA3	SOA2	SOA1	SOA0	ST3	ST2	ST1	ST0	$\overline{\text{OT_latch}}_3$	$\overline{\text{OT_latch}}_2$	X	X
Reset	N/A	N/A	N/A	N/A	N/A	0	0	0	0	0	0	0	0	0	0	0	0	0	0	0	0

s = Output selection with the bits A₁A₀ as defined in [Table 10](#), page 23.

PREVIOUS ADDRESS SOA4:SOA0=A₁A₀000

Bits OD3:OD0 reflect the current state of the Fault register (FLTR) corresponding to the output previously selected with the bits A₁A₀ ([Table 17](#)).

Table 17. Output-Specific Fault Register

OD3	OD2	OD1	OD0
OTF _s	OCHF _s	OCLF _s	OLF _s

s = Selection of the output.

Note The $\overline{\text{FS}}$ pin reports all faults. For latched faults, this pin is reset by a new Switch OFF command (via SPI or direct input IN).

PREVIOUS ADDRESS SOA4:SOA0=00001

Data in bits OD3:OD0 contains IN3_SPI:IN0_SPI programmed bits for outputs HS3:HS0, respectively.

PREVIOUS ADDRESS SOA4:SOA0=01001

Data in bits OD3:OD0 contains the programmed CSNS3 $\overline{\text{EN}}$:CSNS0 $\overline{\text{EN}}$ bits for outputs HS3:HS0, respectively.

PREVIOUS ADDRESS SOA4:SOA0=A₁A₀010

Data returned in bits OD3:OD0 are programmed current values for the overcurrent high detection level (refer to [Table 12](#), page 23) and the overcurrent low detection level (refer to [Table 11](#), page 23), corresponding to the output previously selected with A₁A₀.

PREVIOUS ADDRESS SOA4:SOA0=A₁A₀011

The returned data contains the programmed values in the CDTOLR register for the output selected with A₁A₀.

PREVIOUS ADDRESS SOA4:SOA0=A₁A₀100

The returned data contains the programmed values in the DICR register for the output selected with A₁A₀.

PREVIOUS ADDRESS SOA4:SOA0=00101

The returned data contains the programmed values in the UOVR register.

PREVIOUS ADDRESS SOA4:SOA0=01101

The returned data contains the programmed values in the WDR register. Bit OD2 (WDTO) reflects the status of the watchdog circuitry. If WDTO bit is logic [1], the watchdog has timed out and the device is in Fail-Safe mode. If WDTO is a logic [0], the device is in Normal mode (assuming the device

is powered and not in the Sleep mode), with the watchdog either enabled or disabled.

PREVIOUS ADDRESS SOA4:SOA0=00110

The returned data OD3 and OD2 contain the state of the outputs HS2 and HS0, respectively, in case of Fail-Safe state. This information is stated with the external resistance placed at the FSI pin. OD1 indicates if the watchdog is enabled or not. OD0 returns the state of the WAKE pin.

PREVIOUS ADDRESS SOA4:SOA0=01110

The returned data OD3:OD0 reflects the state of the direct pins IN3:IN0, respectively.

PREVIOUS ADDRESS SOA4:SOA0=01111

The returned data OD3-OD2 reports the overtemperature bits configuration of the outputs [3, 2] set through the WDR SPI register.

TYPICAL APPLICATIONS

INTRODUCTION

The 33580 can be configured in several applications. The figure below shows the 33580 in a typical lighting application.

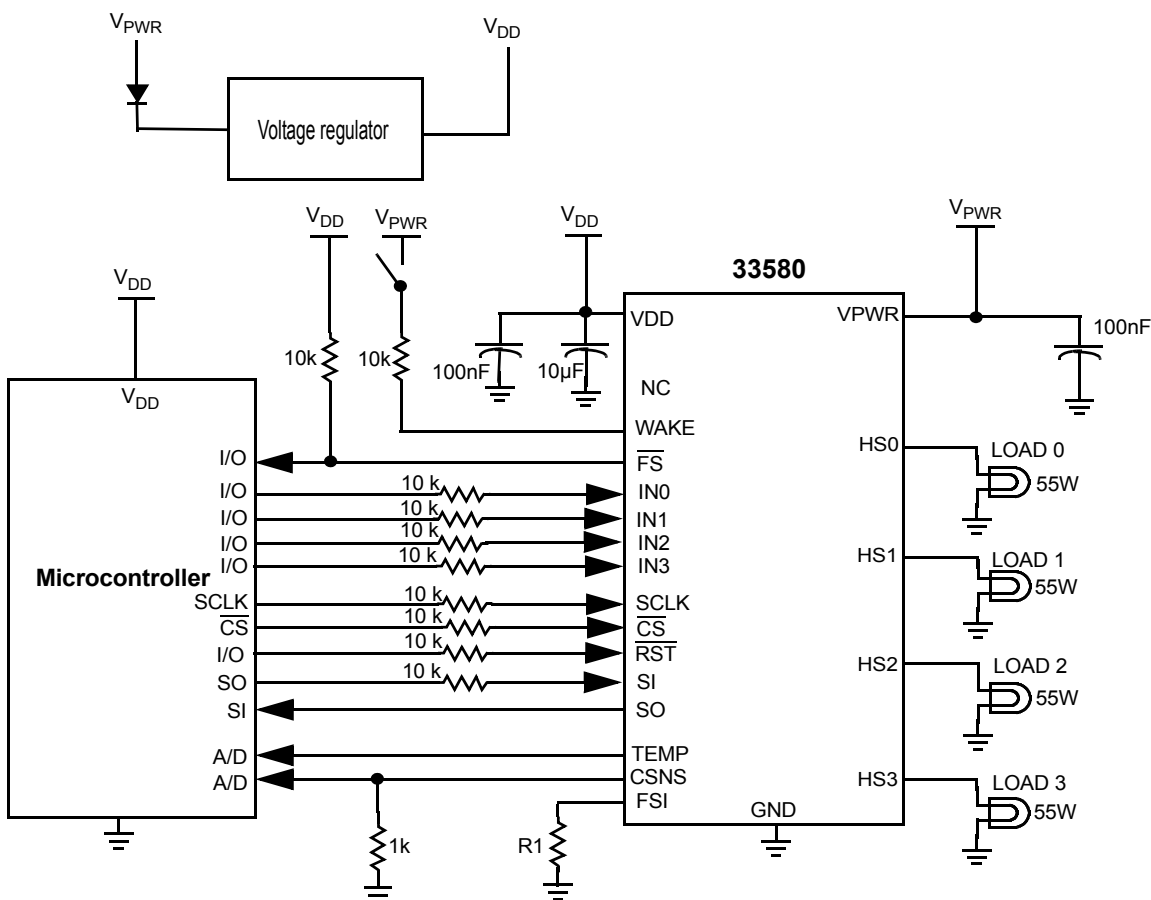

Automotive lamps do not tolerate high voltages very well. Tests of a few lamps indicate that failures can occur when 18V is applied for a few seconds. Consequently, PWM switching reduces the effective RMS voltage in order to drive bulbs safely.

For example, to maintain the power dissipation associated with a 13V battery at 100% duty cycle, the duty cycle would be adjusted to $(13/18)^2$, or 52%, when the battery is at 18V.

The loads must be chosen in order to guarantee the device normal operating condition for junction temperature from -40 to 150 °C. In case of permanent short-circuit conditions, the duration and number of activation cycles must be limited with a dedicated MCU fault management using the fault reporting through the SPI.

STANDBY MODE

This section consists of evaluating the MC33580 standby capability.

CONFIGURATION WITHOUT MCU

The standby mode is intended for customers who desire to plug the device and then immediately “play” with it, without having to connect it to a microcontroller. It also provides an easy way to evaluate the main electrical features.

Without the Microcontroller to select programmable parameters and get full diagnosis via the SPI, the MC33580 runs with all parameters set to default.

The input SPI pin pins and VDD must be connected to ground. Fail safe mode and watchdog timeout must be disabled by connecting the FSI to GND.

All protection functions are available without SPI communication. Nevertheless, any configuration is possible

without an MCU to communicate by SPI. Some functions still enable, but diagnosis is reduced. Available functions and default parameters are detailed next.

FUNCTIONING WITHOUT MCU

Without an MCU, SPI communication is not possible. Fail safe mode and watchdog timeout are not useful functions without an MCU, but still enable. Wake/Sleep mode is used to minimize current consumption during sleep mode. IN pins control the corresponding outputs and \overline{FS} output is active (at 0 V) when a default occurs.

[Table 18](#) illustrates the available functions without SPI and default parameters.

[Table 19](#) illustrates default parameters after resetting or applying supply voltage to the MC33580. Levels and timings are typical values.

Table 18. Available Functions

Function	With SPI	Without SPI
Wake/Sleep mode	Available	Available
Output ON/OFF control	Via SPI or IN pin	Only with IN pin
Over temperature protection	Available, can be unlatched	Available
Over voltage protection	Available, can be disabled	Available, always enable
Under voltage protection	Available, can be disabled	Available, always enable
Over current protection	Available, configurable (with 8 low levels and 2 high levels), can be disabled	Available, always enable with default values
Open load, battery disconnect, reverse battery, ground disconnect protections	Available	Available
Fault diagnosis	Full diagnosis with report by SPI and fault status pin (/FS)	Limited fault diagnosis with Fault status pin only
Current sense	Available, 2 configurable ratios	Not available
Watchdog timeout	Available, 4 configurable timings	Available, default value
Configurable slew rate	2 slew rate modes	Default slew rate mode
Analog temperature feedback	Available	Available

Table 19. Default SPI-Configurable Parameters

Configurable Parameter	Default Typical Value
Over voltage protection	Enable
Under voltage protection	Enable
Over current protection	Enable
Over current low level	OCL00
Over current high level	OCH10
Over current detect blanking time	t_{OCL00}
Current sense	Disable
Watchdog time timeout	T_{WDT00}
Slew rate mode	Slow mode

DIAGNOSIS WITHOUT MCU

When any fault appears (over current, open load...), a full diagnosis can be reported via the SPI. Without an MCU, the

fault status pin allows reduced diagnosis, as illustrated in [Table 20](#).

Table 20. Diagnosis without SPI

	IN[x] Level	HS[x] Level	\overline{FS} Level	Latched
Normal operation	H	H	H	N/A
	L	L	H	
Over temperature	L	L	L	YES
	H	L	L	
Under voltage	L	L	L	YES
	H	L	L	
Over voltage	L	L	H	NO
	H	L	L	
Over current	L	L	H	YES
	H	L	L	
Short circuit to VPWR	L	H	L	NO
	H	H	H	
Open load	L	Z	L	NO
	H	H	H	

H : High Level, L : Low Level, Z : High impedance, potential depends on the external circuit.

We can note that it is not possible to distinguish over temperature, over current, under voltage, and over voltage. Nevertheless, Open load and short circuit to V_{PWR} fault can be singled out. All protections are reported to Fault status pin (\overline{FS}), Open load and short circuit to V_{PWR} are reported only if the Output is OFF. If the fault is latched, the output must be turned OFF then ON to disable the fault.

functioning is safe because all protections are available. Diagnosis is limited, but the fault status pin will report any malfunction.

This is a good way to evaluate the main electrical MC33580 features. Some simplified applications can also use the MC33580 switch without an MCU to drive a high power load with full protection.

CONCLUSION

Although the MC33580 is not fully functional without a microcontroller to control and program it, standalone

PACKAGING

SOLDERING INFORMATION

The 33580 is not designed for immersion soldering. The maximum peak temperature during the soldering process should not exceed 245°C. Terminal soldering limit is for 10 seconds maximum duration. Exceeding these limits may cause malfunction or permanent damage to the device.

PACKAGE DIMENSIONS

For the most current package revision, visit www.freescale.com and perform a keyword search using the 98ART10510D listed below.

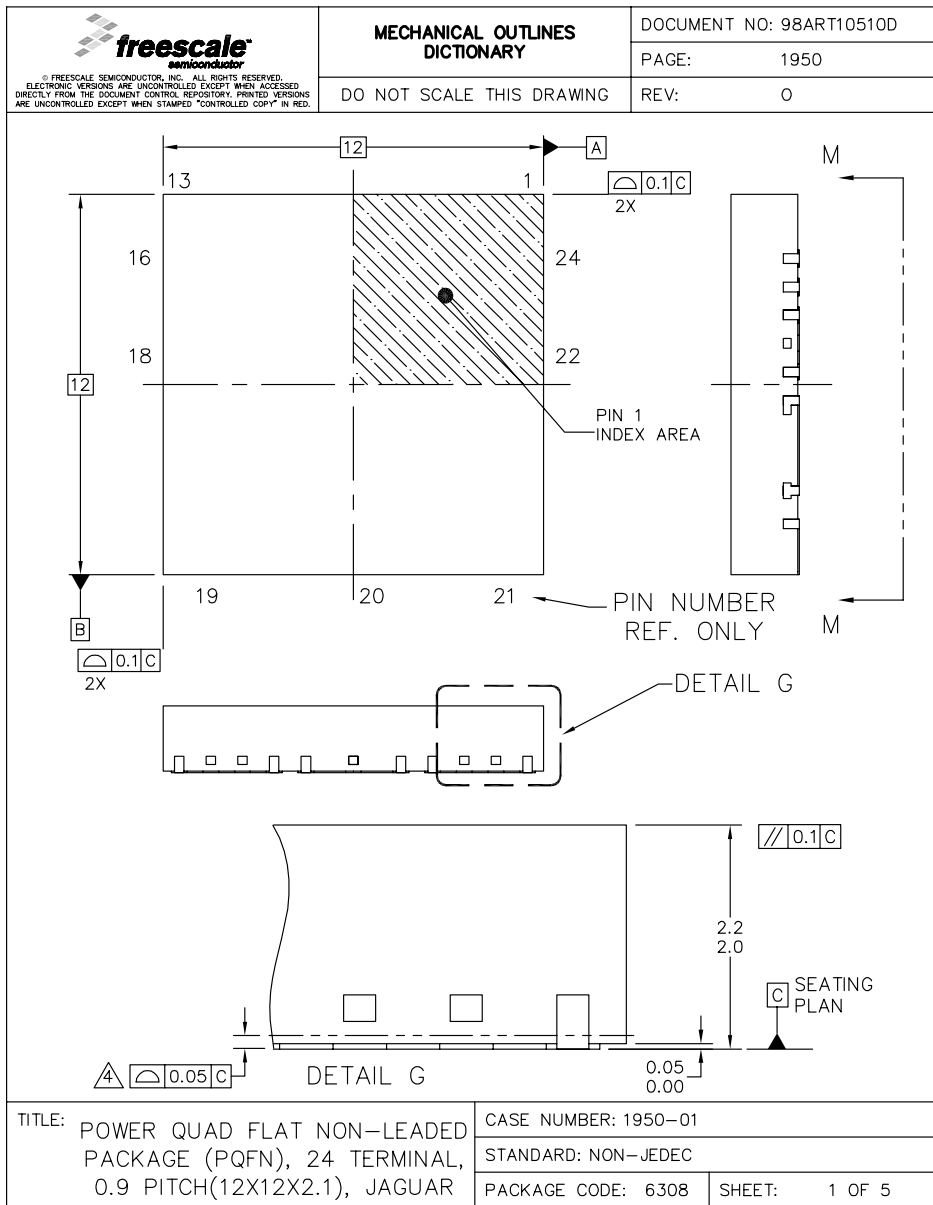

PNA SUFFIX (Pb-FREE)
24-PIN PQFN
NON-LEADED PACKAGE
98ART10511D
ISSUE 0

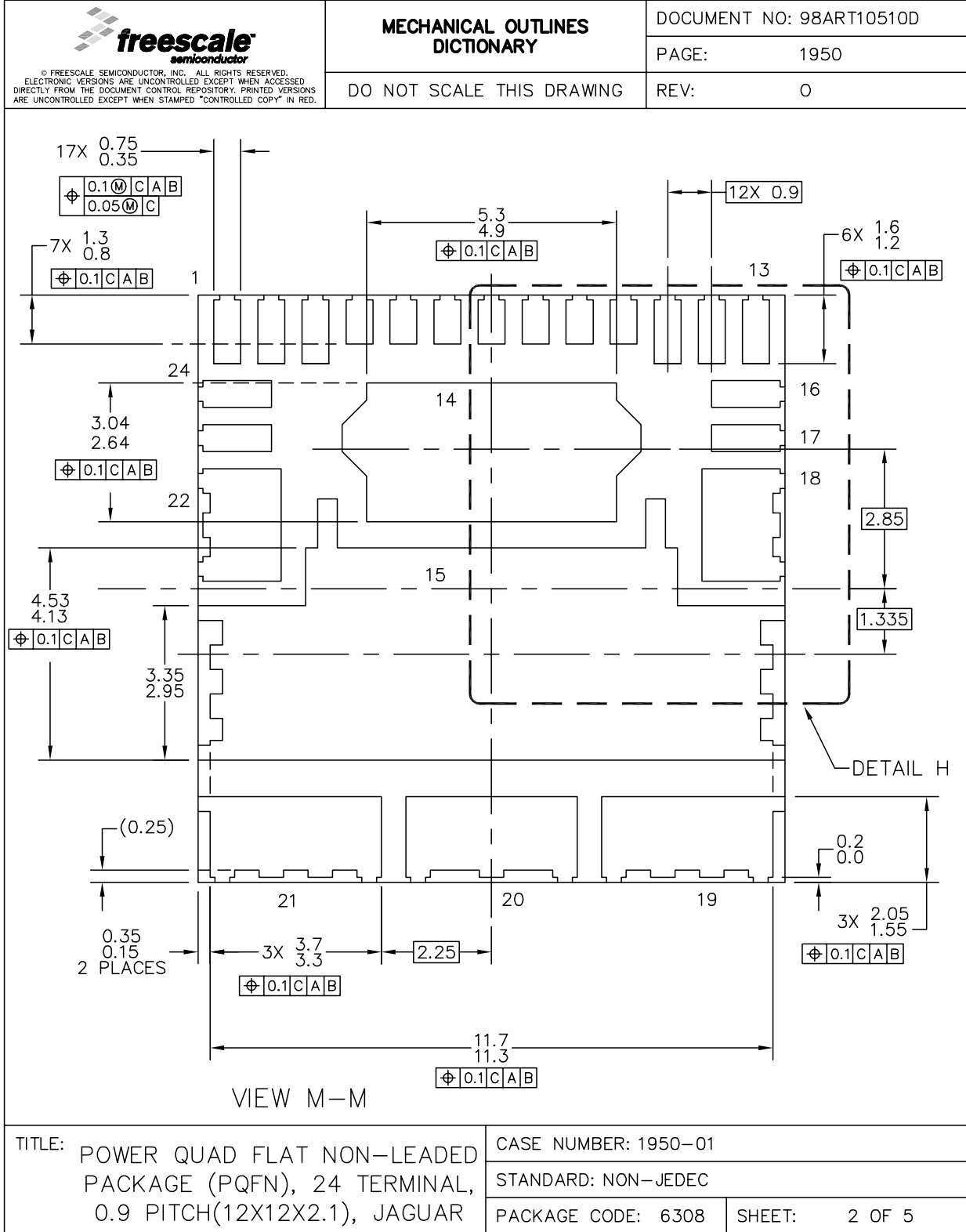

<p>TITLE: POWER QUAD FLAT NON-LEADED PACKAGE (PQFN), 24 TERMINAL, 0.9 PITCH(12X12X2.1), JAGUAR</p>	<p>CASE NUMBER: 1950-01</p> <p>STANDARD: NON-JEDEC</p> <p>PACKAGE CODE: 6308</p>
	<p>SHEET: 2 OF 5</p>

<p>© FREESCALE SEMICONDUCTOR, INC. ALL RIGHTS RESERVED. ELECTRONIC VERSIONS ARE UNCONTROLLED EXCEPT WHEN ACCESSED DIRECTLY FROM THE DOCUMENT CONTROL REPOSITORY. PRINTED VERSIONS ARE UNCONTROLLED EXCEPT WHEN STAMPED "CONTROLLED COPY" IN RED.</p>	MECHANICAL OUTLINES DICTIONARY	DOCUMENT NO: 98ART10510D
		PAGE: 1950
	DO NOT SCALE THIS DRAWING	REV: 0

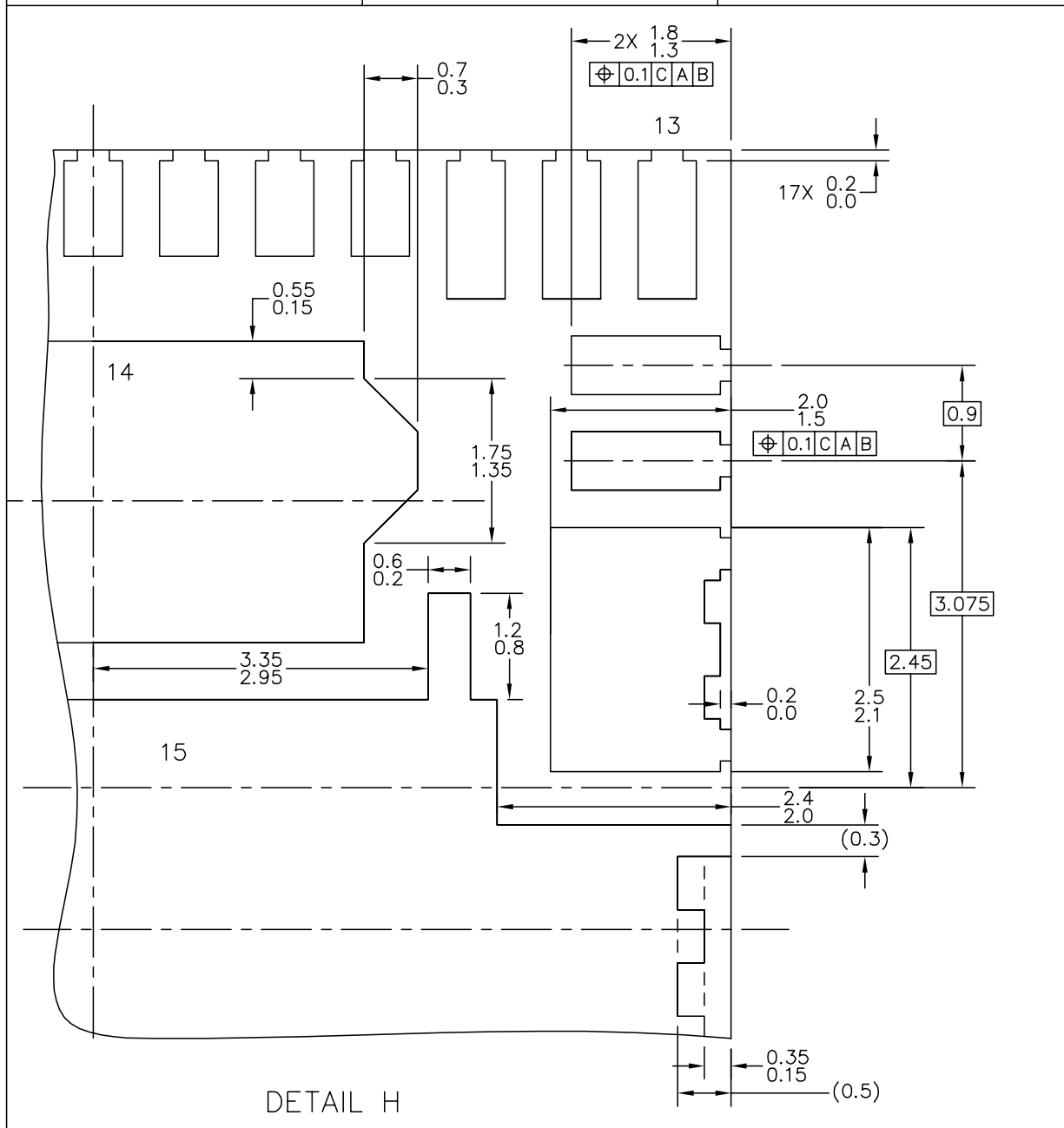

DETAIL H

TITLE: POWER QUAD FLAT NON-LEADED PACKAGE (PQFN), 24 TERMINAL, 0.9 PITCH(12X12X2.1), JAGUAR	CASE NUMBER: 1950-01	
	STANDARD: NON-JEDEC	
	PACKAGE CODE: 6308	SHEET: 3 OF 5

ADDITIONAL DOCUMENTATION

THERMAL ADDENDUM (REV 3.0)

Introduction

This thermal addendum is provided as a supplement to the MC33580 technical datasheet. The addendum provides thermal performance information that may be critical in the design and development of system applications. All electrical, application, and packaging information is provided in the datasheet.

Packaging and Thermal Considerations

This package is a dual die package. There are two heat sources in the package independently heating with P_1 and P_2 . This results in two junction temperatures, T_{J1} and T_{J2} , and a thermal resistance matrix with $R_{\theta JA mn}$.

For $m = 1, n = 1$, $R_{\theta JA11}$ is the thermal resistance from Junction 1 to the reference temperature while only heat source 1 is heating with P_1 .

For $m = 1, n = 2$, $R_{\theta JA12}$ is the thermal resistance from Junction 1 to the reference temperature while heat source 2 is heating with P_2 . This applies to $R_{\theta J21}$ and $R_{\theta J22}$, respectively.

$$\begin{Bmatrix} T_{J1} \\ T_{J2} \end{Bmatrix} = \begin{bmatrix} R_{\theta JA11} & R_{\theta JA12} \\ R_{\theta JA21} & R_{\theta JA22} \end{bmatrix} \cdot \begin{Bmatrix} P_1 \\ P_2 \end{Bmatrix}$$

The stated values are solely for a thermal performance comparison of one package to another in a standardized environment. This methodology is not meant to and will not predict the performance of a package in an application-specific environment. Stated values were obtained by measurement and simulation according to the standards listed below.

Standards

Table 21. Thermal Performance Comparison

Thermal Resistance	1 = Power Chip, 2 = Logic Chip [$^{\circ}\text{C/W}$]		
	$m = 1, n = 1$	$m = 1, n = 2$ $m = 2, n = 1$	$m = 2, n = 2$
$R_{\theta JA mn}$ ^{(1), (2)}	20	16	39
$R_{\theta JB mn}$ ^{(2), (3)}	6	2.0	26
$R_{\theta JA mn}$ ^{(1), (4)}	53	40	73
$R_{\theta JC mn}$ ⁽⁵⁾	<0.5	0.0	1.0

Notes:

- Per JEDEC JESD51-2 at natural convection, still air condition.
- 2s2p thermal test board per JEDEC JESD51-7 and JESD51-5.
- Per JEDEC JESD51-8, with the board temperature on the center trace near the power outputs.
- Single layer thermal test board per JEDEC JESD51-3 and JESD51-5.
- Thermal resistance between the die junction and the exposed pad, "infinite" heat sink attached to exposed pad.

33580PNA

HIGH-SIDE SWITCH

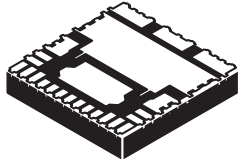

PNA SUFFIX
98ART10510D
24-PIN PQFN (12 x 12)

Note For package dimensions, refer to the 33580 device datasheet.

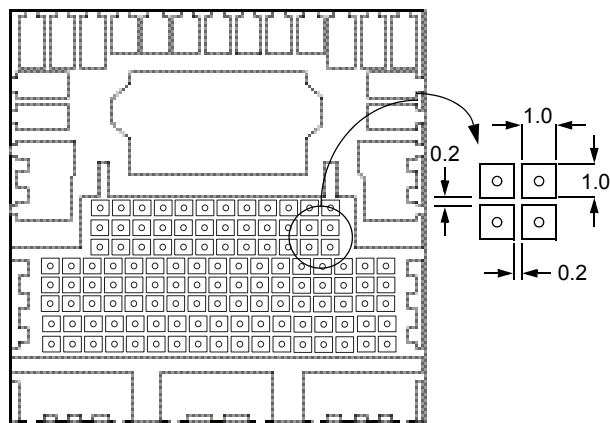

Note: Recommended via diameter is 0.5 mm. PTH (plated through hole) via must be plugged / filled with epoxy or solder mask in order to minimize void formation and to avoid any solder wicking into the via.

Figure 10. Surface mount for power PQFN with exposed pads

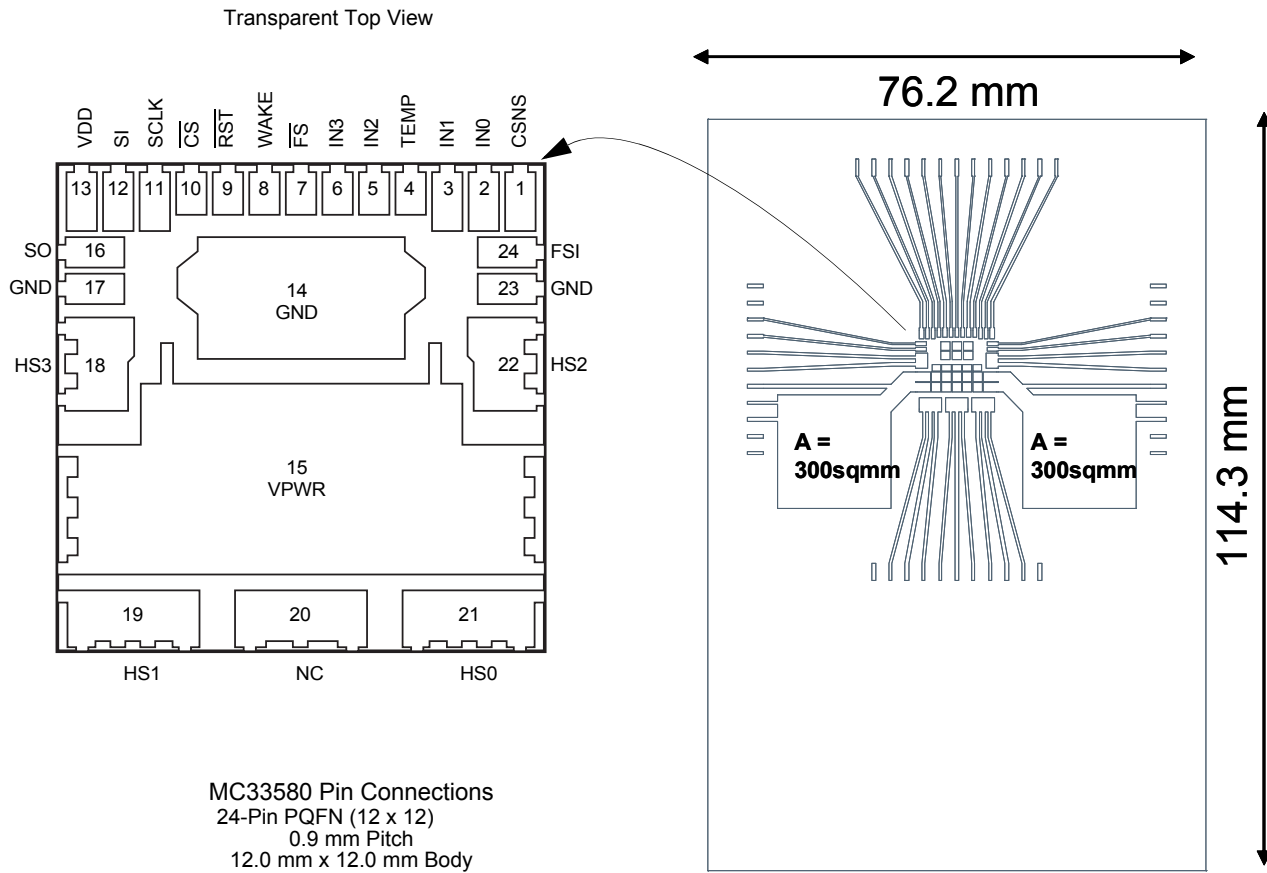

Figure 12. Thermal Test Board

Device on Thermal Test Board

- Material: Single layer printed circuit board
FR4, 1.6 mm thickness
Cu traces, 0.07 mm thickness
- Outline: 80 mm x 100 mm board area,
including edge connector for thermal
testing
- Area **A**: Cu heat-spreading areas on board
surface
- Ambient Conditions: Natural convection, still air

Table 22. Thermal Resistance Performance

Thermal Resistance	Area A (mm ²)	1 = Power Chip, 2 = Logic Chip (°C/W)		
		<i>m</i> = 1, <i>n</i> = 1	<i>m</i> = 1, <i>n</i> = 2 <i>m</i> = 2, <i>n</i> = 1	<i>m</i> = 2, <i>n</i> = 2
$R_{\theta JA mn}$	0	51	38	60
	300	43	32	55
	600	41	30	55

$R_{\theta JA}$ is the thermal resistance between die junction and ambient air.

This device is a dual die package. Index *m* indicates the die that is heated. Index *n* refers to the number of the die where the junction temperature is sensed.

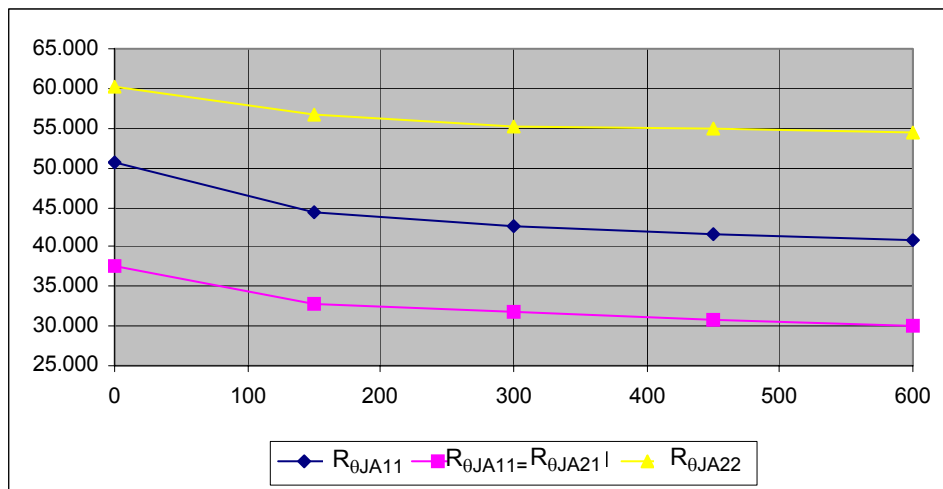

Figure 13. Stead State Thermal Resistance

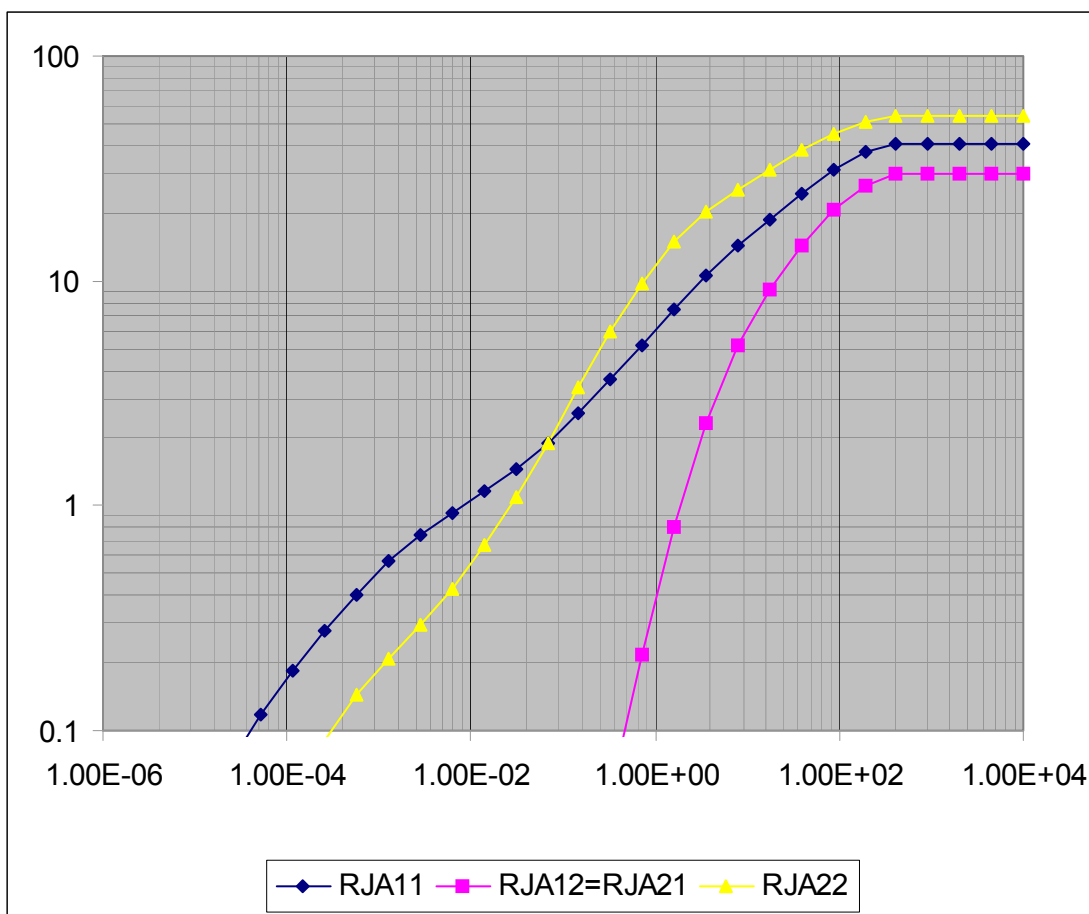

Figure 14. Transient Thermal Resistance

REVISION HISTORY

REVISION	DATE	DESCRIPTION OF CHANGES
2.0	02/2006	<ul style="list-style-type: none"> • Implemented Revision History page • Converted to Freescale format • Added Thermal Addendum
3.0	05/2006	<ul style="list-style-type: none"> • Added B to the part number ordering information. • Minor drawing correction to Figure 1 • Number changes to Selectable Output Current and Programmable Watchdog in Figure 2 • Changed Temperature Feedback Min, Typ, & Max in the Static Electrical Characteristics • Changed max limit on Overcurrent Low Detection Blanking Time for OCLT[1:0] : 11 in the Dynamic Electrical characteristics • Minor corrections in Figure 7, Input Timing Switching Characteristics • Added the sentence "It is recommended to disable the open load detection circuitry in case of permanent disconnected load." to Open Load Fault (Non-Latching) • Changed resistor value for the SPI inputs from 1 k to 10 k in the Typical Applications • Updated the drawings and version on Package Dimensions • Made correction to the 33580 Simplified Internal Block Diagram on the HSO MOSFET.
4.0	6/2006	<ul style="list-style-type: none"> • Changed Note 11 from Guaranteed by design to Guaranteed by process monitoring • Modified Output Turn ON Delay Times on page 11
5.0	9/2006	<ul style="list-style-type: none"> • Adjusted numbers on See Output Rising Fast Slew Rate A (DICR D3 = 1) ⁽¹⁹⁾ on page 10 and See Output Falling Slow Slew Rate A (DICR D3 = 0) ⁽¹⁹⁾ on page 10 • Made additions and corrections to See Typical Applications on page 28 • Made changes to Thermal Addendum (rev 3.0) relating to Figure 12, Table 22, Thermal Resistance Performance, Figure 13, and Figure 14
6.0	4/2007	<ul style="list-style-type: none"> • Changed the package type from 98ARL10596D to 98ART10510D • Removed PC33580BPNA/R2, and added MC33580BAPNA/R2

How to Reach Us:

Home Page:

www.freescale.com

E-mail:

support@freescale.com

USA/Europe or Locations Not Listed:

Freescale Semiconductor
Technical Information Center, CH370
1300 N. Alma School Road
Chandler, Arizona 85224
+1-800-521-6274 or +1-480-768-2130
support@freescale.com

Europe, Middle East, and Africa:

Freescale Halbleiter Deutschland GmbH
Technical Information Center
Schatzbogen 7
81829 Muenchen, Germany
+44 1296 380 456 (English)
+46 8 52200080 (English)
+49 89 92103 559 (German)
+33 1 69 35 48 48 (French)
support@freescale.com

Japan:

Freescale Semiconductor Japan Ltd.
Headquarters
ARCO Tower 15F
1-8-1, Shimo-Meguro, Meguro-ku,
Tokyo 153-0064
Japan
0120 191014 or +81 3 5437 9125
support.japan@freescale.com

Asia/Pacific:

Freescale Semiconductor Hong Kong Ltd.
Technical Information Center
2 Dai King Street
Tai Po Industrial Estate
Tai Po, N.T., Hong Kong
+800 2666 8080
support.asia@freescale.com

For Literature Requests Only:

Freescale Semiconductor Literature Distribution Center
P.O. Box 5405
Denver, Colorado 80217
1-800-441-2447 or 303-675-2140
Fax: 303-675-2150
LDCForFreescaleSemiconductor@hibbertgroup.com

Information in this document is provided solely to enable system and software implementers to use Freescale Semiconductor products. There are no express or implied copyright licenses granted hereunder to design or fabricate any integrated circuits or integrated circuits based on the information in this document.

Freescale Semiconductor reserves the right to make changes without further notice to any products herein. Freescale Semiconductor makes no warranty, representation or guarantee regarding the suitability of its products for any particular purpose, nor does Freescale Semiconductor assume any liability arising out of the application or use of any product or circuit, and specifically disclaims any and all liability, including without limitation consequential or incidental damages. "Typical" parameters that may be provided in Freescale Semiconductor data sheets and/or specifications can and do vary in different applications and actual performance may vary over time. All operating parameters, including "Typicals", must be validated for each customer application by customer's technical experts. Freescale Semiconductor does not convey any license under its patent rights nor the rights of others. Freescale Semiconductor products are not designed, intended, or authorized for use as components in systems intended for surgical implant into the body, or other applications intended to support or sustain life, or for any other application in which the failure of the Freescale Semiconductor product could create a situation where personal injury or death may occur. Should Buyer purchase or use Freescale Semiconductor products for any such unintended or unauthorized application, Buyer shall indemnify and hold Freescale Semiconductor and its officers, employees, subsidiaries, affiliates, and distributors harmless against all claims, costs, damages, and expenses, and reasonable attorney fees arising out of, directly or indirectly, any claim of personal injury or death associated with such unintended or unauthorized use, even if such claim alleges that Freescale Semiconductor was negligent regarding the design or manufacture of the part.

Freescale™ and the Freescale logo are trademarks of Freescale Semiconductor, Inc. All other product or service names are the property of their respective owners.

© Freescale Semiconductor, Inc., 2007. All rights reserved.

Looking for pricing, stock, or lifecycle information?

Click below to explore more details on WIN SOURCE:

 [View MC33580BAPNAR2 on WIN SOURCE](#)

 [NXP / Nexperia Information](#)

Optimize Your Supply Chain with WIN SOURCE Solutions

-  Global Sourcing Solution
-  Obsolete Management
-  Cost Control Management
-  Shortage Management
-  Alternative Solution
-  Excess Inventory Management