



**THE DATASHEET OF  
MC14600P**





# Low-Power CMOS ALARM IC with Horn Driver

The MC14600 Alarm IC is designed to simplify the process of interfacing an alarm level voltage condition to a piezoelectric horn and/or LED. With an extremely low average current requirement and an integrated low battery detect feature, the part is ideally suited to battery operated applications. The MC14600 is easily configured with a minimum number of external components to serve a wide range of applications and circuit configurations. Typical applications include intrusion alarms, moisture or water ingress alarms, and personal safety devices.

## Features

- High Impedance, FET Input Comparator
- Comparator Outputs for Low Battery and Alarm Detect
- Alarm Detect Threshold Easily Established with 2 Resistors
- Integrated Oscillator and Piezoelectric Horn Driver
- Low Battery Trip Point Set Internally (Altered Externally)
- Horn "Chirp" During Low Battery Condition
- Pulsed LED Drive Output
- Reverse Battery Protection
- Input Protection Diodes on the Detect Input
- Average Supply Current: 9  $\mu$ A
- Pb-Free Packaging Designated by Suffix Codes ED and EG

## ORDERING INFORMATION

Device	Case No.	Package
MC14600P	648-08	16 PDIP
MC14600DW/R2	751G-04	16 SOIC
MCZ14600EG/R2		16 SOIC (Pb-free)

14600

LOW-POWER CMOS  
ALARM IC  
WITH HORN DRIVER

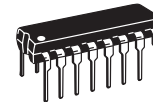

P SUFFIX  
ED SUFFIX (PB-FREE)  
16-LEAD PLASTIC DIP  
CASE 648-08

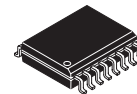

DW SUFFIX  
EG SUFFIX (PB-FREE)  
16-LEAD SOIC  
CASE 751G-04

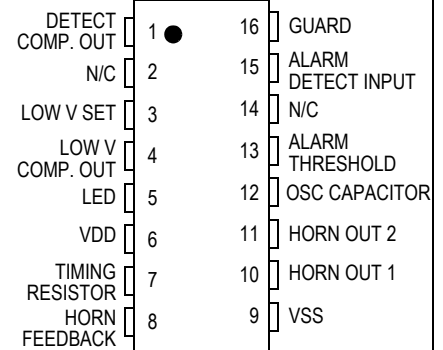

Figure 1. Pin Connections

Archive Information

Archive Information



Archive Information

Archive Information

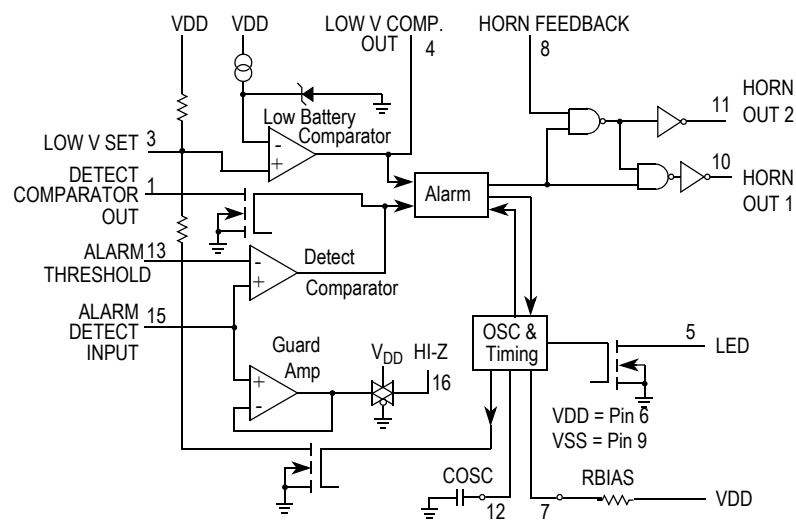

Figure 2. 14600 Block Diagram

Table 1. Maximum Ratings<sup>1</sup>  
(Voltages referenced to V<sub>SS</sub>)

Rating	Symbol	Value	Unit
DC Supply Voltage	V <sub>DD</sub>	-0.5 to +15	V
Input Voltage, All Inputs Except Pin 8	V <sub>IN</sub>	-0.25 to V <sub>DD</sub> +0.25	V
DC Current Drain per Input Pin Except Pin 15 = 1 mA	I	10	mA
DC Current Drain per Output Pin	I	30	mA
Operating Temperature Range	T <sub>A</sub>	-10 to +60°C	°C
Storage Temperature Range	T <sub>STG</sub>	-55 to +125	°C
Reverse Battery Time	t <sub>RB</sub>	5.0	s

1. Maximum Ratings are those values beyond which damage to the device may occur. This device contains circuitry to protect the inputs against damage due to high static voltages or electric fields; however, it is advised normal precautions be taken to avoid application of any voltage higher than maximum rated voltages to this high impedance circuit. For proper operation, it is recommended V<sub>IN</sub> and V<sub>OUT</sub> be constrained to the range V<sub>SS</sub> ≤ (V<sub>IN</sub> or V<sub>OUT</sub>) ≤ V<sub>DD</sub>.

Table 2. Recommended Operating Conditions  
(Voltages referenced to V<sub>SS</sub>)

Parameter	Symbol	Value	Unit
Supply Voltage	V <sub>DD</sub>	9.0	V
LED Load (Pin 5)	—	10	mA

**Table 3. Electrical Characteristics**

 (Voltages referenced to  $V_{CC}$ ,  $T_A = 25^\circ\text{C}$ )

Characteristics	Symbol	$V_{DD}/V_{DC}$	Min	Typ <sup>1</sup>	Max	Unit
Operating Voltage	$V_{DD}$	—	6.0	—	12	V
Output Voltage Piezoelectric Horn Drivers ( $I_{OH} = +16$ mA), Pins 10, 11 Comparators ( $I_{OH} = +30$ $\mu\text{A}$ ), Pin 4	$V_{OH}$	7.4 9.0	6.5 8.5	— 8.8	— —	V
Piezoelectric Horn Drivers ( $I_{OL} = -16$ mA), Pins 10, 11 Comparators ( $I_{OL} = -30$ $\mu\text{A}$ ), Pin 4 ( $I_{OL} = -200$ $\mu\text{A}$ ), Pin 1	$V_{OL}$	7.4 9.0 —	— — —	— 0.1 —	0.9 0.5 0.5	V
Output Voltage — LED Driver, $I_{OL} = 10$ mA, Pin 5	$V_{OL}$	7.2	—	—	2.0	V
Output Impedance, Active Guard, Pin 16	HI-Z	9.0	—	—	1000	$k\Omega$
Standby Current ( $R_{BIAS} = 8.2$ M $\Omega$ )	$I_{DD}$	9.0 12.0	— —	5.0 —	9.0 12.0	$\mu\text{A}$
Input Leakage Current Pin 1 Pin 8 Pin 13	— $I_{IN}$ —	9.0 9.0 9.0	— — —	— — —	$\pm 30$ $\pm 0.1$ $\pm 30$	nA $\mu\text{A}$ nA
Detect Comparator Out , Pin 1 $V = 3.0$ V $V = 9.0$ V	— —	— —	2.50 —	— —	— 8.00	mA mA
Low Battery Threshold Voltage (Pin 3 Open), Pin 6	$V_{LOW}$	9.0	7.2	—	7.8	V
Offset Voltage (Measured at $V_{IN} = V_{DD}/2$ ) Active Guard Detect Comparator	$V_{OS}$	9.0 9.0	— —	— —	$\pm 100$ $\pm 50$	mV
Input Voltage Range, Pin 8	$V_{IN}$	—	$V_{SS} - 10$	—	$V_{DD} + 10$	V
Input Capacities (to $V_{SS}$ @ 1 kHz), Pin 15	$C_{IN}$	—	—	5.0	—	pF
Common Mode Voltage Range, Pins 13, 15	$V_{CM}$	—	1.5	—	$V_{DD} - 2$	V
Breakdown Voltage, All Pins Except 15	—	—	$\pm 500$	—	—	V
Human Body Models/MIL–STD–883 Method 3015, Pin 15	—	—	$\pm 400$	—	—	V

1. Data labelled "1yp" is not to be used for design purposes, but is intended as an indication of the IC's potential performance.

**Table 4. Timing Parameters**

 ( $C_{OSC} = 0.1$   $\mu\text{F}$ ,  $R_{BIAS} = 8.2$  M $\Omega$ ,  $V_{DD} = 9.0$  V,  $T_A = 25^\circ\text{C}$ , see Figure 3.)

Characteristic		Pin #	Symbol	Min	Max	Units
Oscillator Period (1 Clock Cycle = 1 Oscillator Period)	No Alarm	12	$t_{CI}$	1.25	2.25	s
	Alarm		—	30	52	ms
Oscillator Pulse Width (No Alarm and Alarm Condition)		3, 4, 5, 13	$t_r$	7.0	13	ms
LED Output Period	No Alarm	5	$t_{LED}$	30	52	s
	Alarm		—	.71	1.25	ms
Alarm Horn Output	Hi Time	10, 11	$t_{ON}$	120	208	ms
	Low Time		$t_{OFF}$	60	104	ms
Low Battery Horn Output	Hi Time	10, 11	$t_{ON}$	7.0	13	ms
	Between Pulses		$t_{OFF}$	30	52	s

## DEVICE OPERATION

### Timing

The internal oscillator of the MC14600 operates with a period of 1.65 seconds during no-alarm conditions. Each 1.65 seconds, internal power is applied to the entire IC and a check is made for an alarm input level except during LED pulse, Low Battery Alarm Chirp, or Horn Modulation (in alarm). Every 24 clock cycles a check is made for low battery by comparing  $V_{DD}$  to an internal zener voltage. Since very small currents are used in the oscillator, the oscillator capacitor should be of a low leakage type.

### Detect Circuitry

If an alarm condition is detected, the oscillator period becomes 41.67 ms and the piezoelectric horn oscillator circuit is enabled. The horn output is modulated 167 ms on, 83 ms off. During the off time, alarm detect input (Pin 15) is again checked and will inhibit further horn output if no alarm condition is sensed. During alarm conditions the low battery chirp is inhibited, and the LED pulses at a 1.0 Hz rate.

An active guard is provided on a pin adjacent to the detect input (Pin 16). The voltage at this pin will be within 100 mV of the input signal. Pin 16 will allow monitoring of the input signal at pin 15 through a buffer. The active guard op amp is not

power strobed and thus gives constant protection from surface leakage currents. Pin 15 (the Detect input) has internal diode protection against static damage.

### Low Battery Threshold

The low battery voltage level is set internally by a voltage divider connected between VDD and VSS. This voltage can be altered by external resistors connected from pin 3 to either VDD or VSS. A resistor to VDD will decrease the threshold while a resistor to GND will increase it.

### Alarm Threshold (Sensitivity)

The alarm condition voltage level is set externally through Pin 13. A voltage divider can be used to set the alarm trip point. Pin 13 is connected internally to the negative input of the detect comparator.

### LED Pulse

The 9-volt battery level is checked every 40 seconds during the LED pulse. The battery is loaded via a 10 mA pulse for 10 ms. If the LED is not used, it should be replaced with an equivalent resistor so that the battery loading remains at 10 mA.

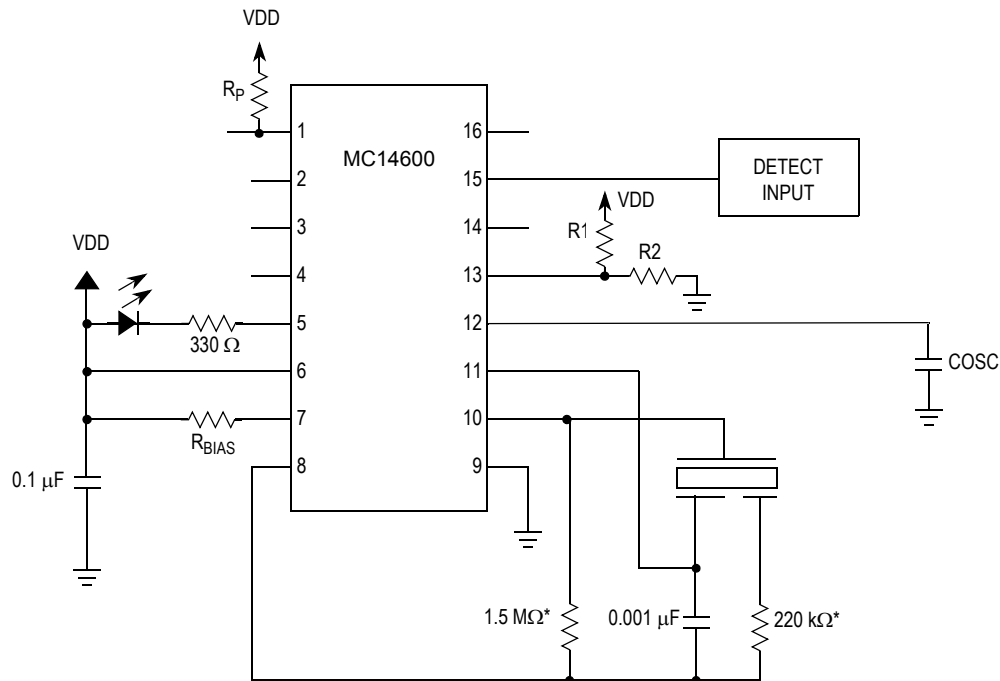

\*Note: Component values may change depending on the type of piezoelectric horn used.

**Figure 3. Typical Application Components**



Archive Information

Archive Information

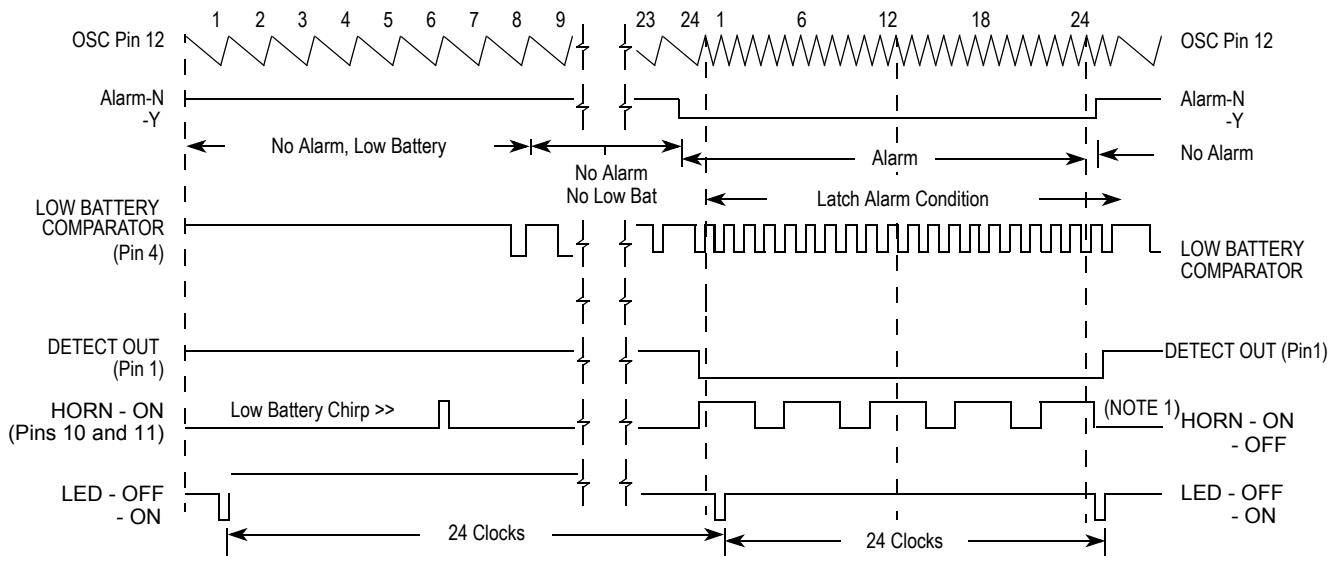

Figure 4. MC14600 Timing Diagram

NOTE:

1. Horn modulation is self-completing. When going from Alarm to No Alarm, the alarm condition will terminate only when horn is off.
2. Comparators are strobed once per cycle.
3. Low Battery comparator information is latched only during LED pulse.
4. Current source required into Pin 1.
5. Alarm Condition can initiate on any clock pulse except 1 and 7.



PACKAGING

### PACKAGING

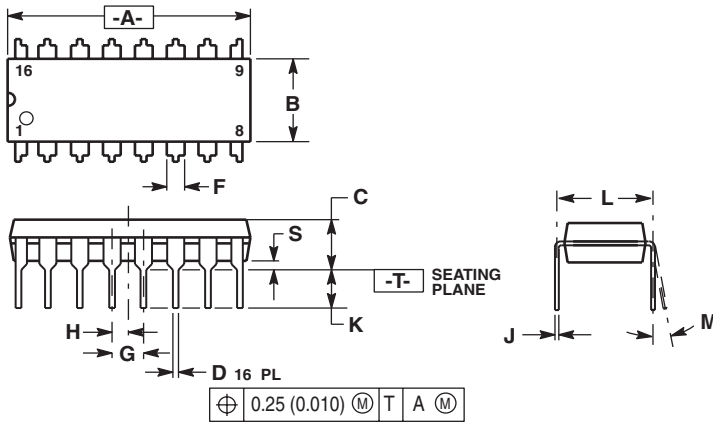

- NOTES:
1. DIMENSIONING AND TOLERANCING PER ANSI Y14.5M, 1982.
  2. CONTROLLING DIMENSION: INCH.
  3. DIMENSION L TO CENTER OF LEADS WHEN FORMED PARALLEL.
  4. DIMENSION B DOES NOT INCLUDE MOLD FLASH.
  5. ROUNDED CORNERS OPTIONAL.

DIM	INCHES		MILLIMETERS	
	MIN	MAX	MIN	MAX
A	0.740	0.770	18.80	19.55
B	0.250	0.270	6.35	6.85
C	0.145	0.175	3.69	4.44
D	0.015	0.021	0.39	0.53
F	0.040	0.70	1.02	1.77
G	0.100 BSC		2.54 BSC	
H	0.050 BSC		1.27 BSC	
J	0.008	0.015	0.21	0.38
K	0.110	0.130	2.80	3.30
L	0.295	0.305	7.50	7.74
M	0	10	0	10
S	0.020	0.040	0.51	1.01

- |                |                     |
|----------------|---------------------|
| STYLE 1:       | STYLE 2:            |
| PIN 1. CATHODE | PIN 1. COMMON DRAIN |
| 2. CATHODE     | 2. COMMON DRAIN     |
| 3. CATHODE     | 3. COMMON DRAIN     |
| 4. CATHODE     | 4. COMMON DRAIN     |
| 5. CATHODE     | 5. COMMON DRAIN     |
| 6. CATHODE     | 6. COMMON DRAIN     |
| 7. CATHODE     | 7. COMMON DRAIN     |
| 8. CATHODE     | 8. COMMON DRAIN     |
| 9. ANODE       | 9. GATE             |
| 10. ANODE      | 10. SOURCE          |
| 11. ANODE      | 11. GATE            |
| 12. ANODE      | 12. SOURCE          |
| 13. ANODE      | 13. GATE            |
| 14. ANODE      | 14. SOURCE          |
| 15. ANODE      | 15. GATE            |
| 16. ANODE      | 16. SOURCE          |

**CASE 751G-04  
ISSUE D  
16-LEAD SOIC**

**DATE 05/18/88**

Archive Information

Archive Information

Archive Information

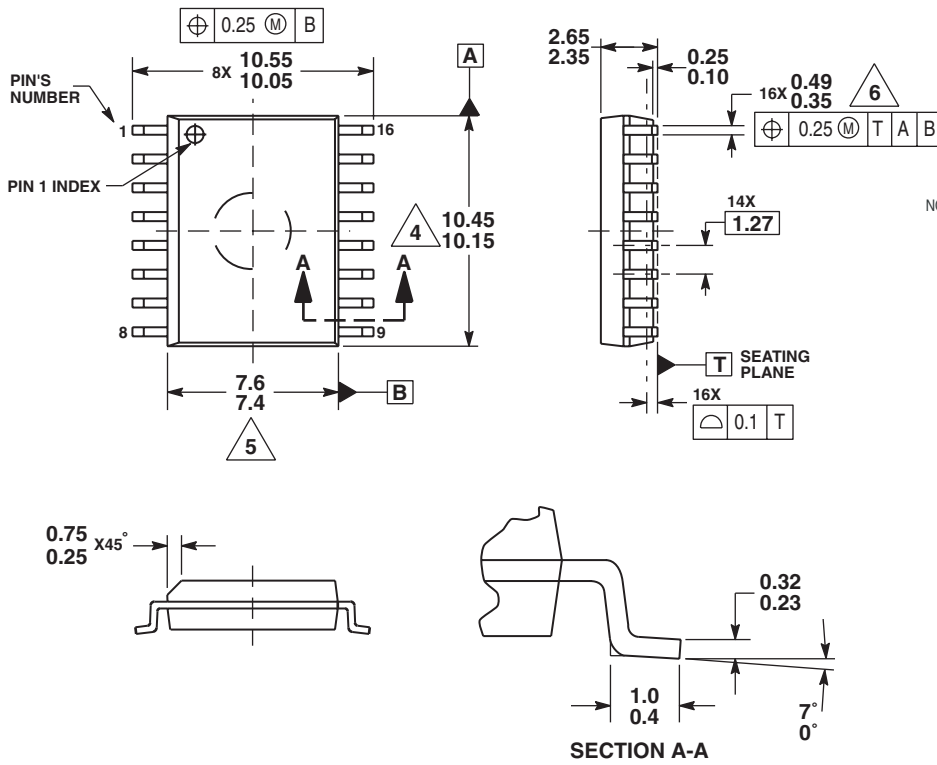

Archive Information

DATE 03/05/0

**CASE 751G-04**  
**ISSUE D**  
**16-LEAD SOIC**



### How to Reach Us:

**Home Page:**  
www.freescale.com

**E-mail:**  
support@freescale.com

**USA/Europe or Locations Not Listed:**  
Freescale Semiconductor  
Technical Information Center, CH370  
1300 N. Alma School Road  
Chandler, Arizona 85224  
+1-800-521-6274 or +1-480-768-2130  
support@freescale.com

**Europe, Middle East, and Africa:**  
Freescale Halbleiter Deutschland GmbH  
Technical Information Center  
Schatzbogen 7  
81829 Muenchen, Germany  
+44 1296 380 456 (English)  
+46 8 52200080 (English)  
+49 89 92103 559 (German)  
+33 1 69 35 48 48 (French)  
support@freescale.com

**Japan:**  
Freescale Semiconductor Japan Ltd.  
Headquarters  
ARCO Tower 15F  
1-8-1, Shimo-Meguro, Meguro-ku,  
Tokyo 153-0064  
Japan  
0120 191014 or +81 3 5437 9125  
support.japan@freescale.com

**Asia/Pacific:**  
Freescale Semiconductor Hong Kong Ltd.  
Technical Information Center  
2 Dai King Street  
Tai Po Industrial Estate  
Tai Po, N.T., Hong Kong  
+800 2666 8080  
support.asia@freescale.com

**For Literature Requests Only:**  
Freescale Semiconductor Literature Distribution Center  
P.O. Box 5405  
Denver, Colorado 80217  
1-800-441-2447 or 303-675-2140  
Fax: 303-675-2150  
LDCForFreescaleSemiconductor@hibbertgroup.com

RoHS-compliant and/or Pb-free versions of Freescale products have the functionality and electrical characteristics of their non-RoHS-compliant and/or non-Pb-free counterparts. For further information, see <http://www.freescale.com> or contact your Freescale sales representative.

For information on Freescale's Environmental Products program, go to <http://www.freescale.com/epp>.

Information in this document is provided solely to enable system and software implementers to use Freescale Semiconductor products. There are no express or implied copyright licenses granted hereunder to design or fabricate any integrated circuits or integrated circuits based on the information in this document.

Freescale Semiconductor reserves the right to make changes without further notice to any products herein. Freescale Semiconductor makes no warranty, representation or guarantee regarding the suitability of its products for any particular purpose, nor does Freescale Semiconductor assume any liability arising out of the application or use of any product or circuit, and specifically disclaims any and all liability, including without limitation consequential or incidental damages. "Typical" parameters that may be provided in Freescale Semiconductor data sheets and/or specifications can and do vary in different applications and actual performance may vary over time. All operating parameters, including "Typicals", must be validated for each customer application by customer's technical experts. Freescale Semiconductor does not convey any license under its patent rights nor the rights of others. Freescale Semiconductor products are not designed, intended, or authorized for use as components in systems intended for surgical implant into the body, or other applications intended to support or sustain life, or for any other application in which the failure of the Freescale Semiconductor product could create a situation where personal injury or death may occur. Should Buyer purchase or use Freescale Semiconductor products for any such unintended or unauthorized application, Buyer shall indemnify and hold Freescale Semiconductor and its officers, employees, subsidiaries, affiliates, and distributors harmless against all claims, costs, damages, and expenses, and reasonable attorney fees arising out of, directly or indirectly, any claim of personal injury or death associated with such unintended or unauthorized use, even if such claim alleges that Freescale Semiconductor was negligent regarding the design or manufacture of the part.

Freescale™ and the Freescale logo are trademarks of Freescale Semiconductor, Inc. All other product or service names are the property of their respective owners.

© Freescale Semiconductor, Inc., 2007. All rights reserved.

## Looking for pricing, stock, or lifecycle information?

Click below to explore more details on WIN SOURCE:

 [View MC14600P](#) on WIN SOURCE

 [NXP / Nexperia](#) Information

## Optimize Your Supply Chain with WIN SOURCE Solutions

-  Global Sourcing Solution
-  Obsolete Management
-  Cost Control Management
-  Shortage Management
-  Alternative Solution
-  Excess Inventory Management