



**THE DATASHEET OF
MC100ELT21DTR2G**



MC10ELT21, MC100ELT21

5 V Differential PECL to TTL Translator

Description

The MC10ELT/100ELT21 is a differential PECL to TTL translator. Because PECL (Positive ECL) levels are used, only +5 V and ground are required. The small outline 8-lead package and the single gate of the ELT21 makes it ideal for those applications where space, performance and low power are at a premium.

The V_{BB} pin, an internally generated voltage supply, is available to this device only. For single-ended input conditions, the unused differential input is connected to V_{BB} as a switching reference voltage. V_{BB} may also rebias AC coupled inputs. When used, decouple V_{BB} and V_{CC} via a 0.01 μ F capacitor and limit current sourcing or sinking to 0.5 mA. When not used, V_{BB} should be left open.

The 100 Series contains temperature compensation.

Features

- 3.5 ns Typical Propagation Delay
- 24 mA TTL Output
- Flow Through Pinouts
- Operating Range: $V_{CC} = 4.75$ V to 5.25 V with GND = 0 V
- Q Output Will Default LOW with Inputs Left Open or < 1.3 V
- These Devices are Pb-Free, Halogen Free/BFR Free and are RoHS Compliant



ON Semiconductor®

www.onsemi.com

MARKING DIAGRAMS*



SOIC-8
D SUFFIX
CASE 751

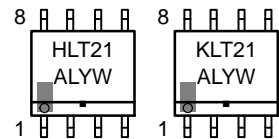

TSSOP-8
DT SUFFIX
CASE 948R

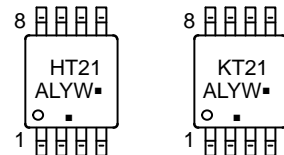

H = MC10
K = MC100

A = Assembly Location
L = Wafer Lot
Y = Year
W = Work Week
▪ = Pb-Free Package

(Note: Microdot may be in either location)

*For additional marking information, refer to Application Note AND8002/D.

ORDERING INFORMATION

See detailed ordering and shipping information in the package dimensions section on page 5 of this data sheet.

MC10ELT21, MC100ELT21

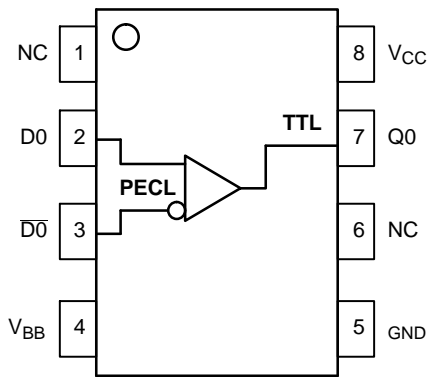

Figure 1. 8-Lead Pinout and Logic Diagram
(Top View)

Table 1. PIN DESCRIPTION

Pin	Function
Q0	TTL Outputs
D0, $\overline{D0}$	PECL Differential Outputs
V_{BB}	Reference Voltage Output
V_{CC}	Positive Supply
GND	Ground
NC	No Connect

Table 2. ATTRIBUTES

Characteristics	Value
Internal Input Pulldown Resistor	50 k Ω
Internal Input Pullup Resistor	N/A
ESD Protection Human Body Model	> 2 kV
Moisture Sensitivity, Indefinite Time Out of Drypack (Note 1)	Pb-Free Pkg
	SOIC-8 TSSOP-8
	Level 1 Level 3
Flammability Rating Oxygen Index: 28 to 34	UL 94 V-0 @ 0.125 in
Transistor Count	81 Devices
Meets or exceeds JEDEC Spec EIA/JESD78 IC Latchup Test	

1. For additional information, see Application Note AND8003/D.

Table 3. MAXIMUM RATINGS

Symbol	Parameter	Condition 1	Condition 2	Rating	Unit
V_{CC}	PECL Power Supply	GND = 0 V		7	V
V_{IN}	PECL Input Voltage	GND = 0 V	$V_I \leq V_{CC}$	0 to 6	V
I_{BB}	V_{BB} Sink/Source			± 0.5	mA
T_A	Operating Temperature Range			-40 to +85	$^{\circ}\text{C}$
T_{stg}	Storage Temperature Range			-65 to +150	$^{\circ}\text{C}$
θ_{JA}	Thermal Resistance (Junction-to-Ambient)	0 lfpm 500 lfpm	SOIC-8 SOIC-8	190 130	$^{\circ}\text{C}/\text{W}$ $^{\circ}\text{C}/\text{W}$
θ_{JC}	Thermal Resistance (Junction-to-Case)	Standard Board	SOIC-8	41 to 44	$^{\circ}\text{C}/\text{W}$
θ_{JA}	Thermal Resistance (Junction-to-Ambient)	0 lfpm 500 lfpm	TSSOP-8 TSSOP-8	185 140	$^{\circ}\text{C}/\text{W}$ $^{\circ}\text{C}/\text{W}$
T_{sol}	Wave Solder Pb-Free	<2 to 3 sec @ 260 $^{\circ}\text{C}$		265	$^{\circ}\text{C}$

Stresses exceeding those listed in the Maximum Ratings table may damage the device. If any of these limits are exceeded, device functionality should not be assumed, damage may occur and reliability may be affected.

MC10ELT21, MC100ELT21

Table 4. 10ELT SERIES PECL INPUT DC CHARACTERISTICS $V_{CC} = 5.0\text{ V}$; $GND = 0.0\text{ V}$ (Note 2)

Symbol	Characteristic	-40°C			25°C			85°C			Unit
		Min	Typ	Max	Min	Typ	Max	Min	Typ	Max	
V_{IH}	Input HIGH Voltage (Single-Ended)	3770		4110	3870		4190	3930		4265	mV
V_{IL}	Input LOW Voltage (Single-Ended)	3050		3500	3050		3520	3050		3555	mV
V_{BB}	Output Voltage Reference	3.57		3.7	3.65		3.75	3.69		3.81	V
V_{IHCMR}	Input HIGH Voltage Common Mode Range (Differential Configuration) (Note 3)	2.2		5.0	2.2		5.0	2.2		5.0	V
I_{IH}	Input HIGH Current			255			175			175	μA
I_{IL}	Input LOW Current	0.5			0.5			0.3			μA

NOTE: Device will meet the specifications after thermal equilibrium has been established when mounted in a test socket or printed circuit board with maintained transverse airflow greater than 500 lfpm.

- Output parameters vary 1:1 with V_{CC} . V_{CC} can vary $\pm 0.25\text{ V}$.
- V_{IHCMR} min varies 1:1 with GND , V_{IHCMR} max varies 1:1 with V_{CC} .

Table 5. 100ELT SERIES PECL INPUT DC CHARACTERISTICS $V_{CC} = 5.0\text{ V}$; $GND = 0.0\text{ V}$ (Note 4)

Symbol	Characteristic	-40°C			25°C			85°C			Unit
		Min	Typ	Max	Min	Typ	Max	Min	Typ	Max	
V_{IH}	Input HIGH Voltage (Single-Ended)	3835		4120	3835		4120	3835		4120	mV
V_{IL}	Input LOW Voltage (Single-Ended)	3190		3525	3190		3525	3190		3525	mV
V_{BB}	Output Voltage Reference	3.62		3.74	3.62		3.74	3.62		3.745	V
V_{IHCMR}	Input HIGH Voltage Common Mode Range (Differential Configuration) (Note 5)	2.2		5.0	2.2		5.0	2.2		5.0	V
I_{IH}	Input HIGH Current			255			175			175	μA
I_{IL}	Input LOW Current	0.5			0.5			0.5			μA

NOTE: Device will meet the specifications after thermal equilibrium has been established when mounted in a test socket or printed circuit board with maintained transverse airflow greater than 500 lfpm.

- Input parameters vary 1:1 with V_{CC} . V_{CC} can vary $\pm 0.25\text{ V}$.
- V_{IHCMR} min varies 1:1 with GND , V_{IHCMR} max varies 1:1 with V_{CC} .

Table 6. TTL OUTPUT DC CHARACTERISTICS $V_{CC} = 4.75\text{ V}$ to 5.25 V ; $T_A = -40^\circ\text{C}$ to 85°C

Symbol	Characteristic	Condition	Min	Typ	Max	Unit
V_{OH}	Output HIGH Voltage	$I_{OH} = -3.0\text{ mA}$	2.4		(Note 6)	V
V_{OL}	Output LOW Voltage	$I_{OL} = 24\text{ mA}$			0.5	V
I_{CCH}	Power Supply Current			20	29	mA
I_{CCL}	Power Supply Current			22	32	mA
I_{OS}	Output Short Circuit Current		-150		-60	mA

NOTE: Device will meet the specifications after thermal equilibrium has been established when mounted in a test socket or printed circuit board with maintained transverse airflow greater than 500 lfpm.

- Maximum level is $V_{CC} - 0.7$ by design.

MC10ELT21, MC100ELT21

AC CHARACTERISTICS $V_{CC} = 4.75\text{ V to }5.25\text{ V}$; $GND = 0.0\text{ V}$ (Note 7)

Symbol	Characteristic	-40°C			25°C			85°C			Unit
		Min	Typ	Max	Min	Typ	Max	Min	Typ	Max	
f_{max}	Maximum Toggle Frequency					100					MHz
t_{JITTER}	Random Clock Jitter (RMS)					35					ps
t_{PLH}	Propagation Delay @ 1.5 V	2.0		5.5	2.0		5.5	2.0		5.5	ns
t_{PHL}	Propagation Delay @ 1.5 V	2.0		5.5	2.0		5.5	2.0		5.5	ns
V_{PP}	Input Swing (Note 8)	200		1000	200		1000	200		1000	mV
t_r/t_f	Output Rise/Fall Time (10–90%)					750					ps

NOTE: Device will meet the specifications after thermal equilibrium has been established when mounted in a test socket or printed circuit board with maintained transverse airflow greater than 500 lfpm.

7. $R_L = 500\ \Omega$ to GND and $C_L = 20\text{ pF}$ to GND. Refer to Figure 2.

8. $V_{PP}(\text{min})$ is the minimum input swing for which AC parameters are guaranteed. The device has a DC gain of ≈ 40 .

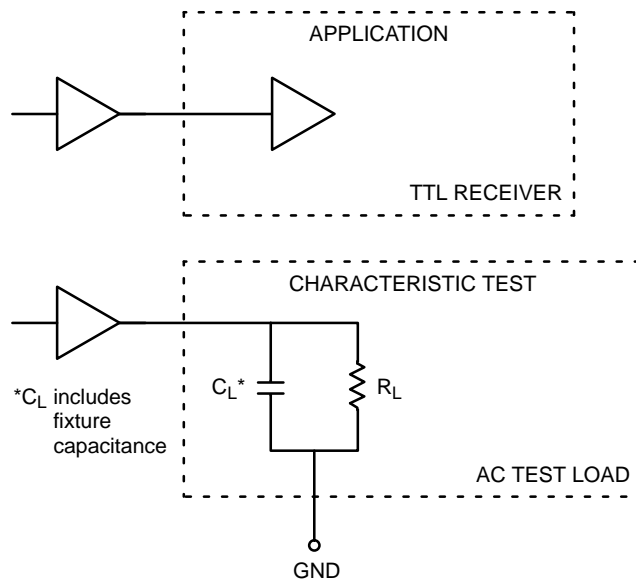

Figure 2. TTL Output Loading Used for Device Evaluation

MC10ELT21, MC100ELT21

ORDERING INFORMATION

Device	Package	Shipping†
MC10ELT21DG	SOIC-8 (Pb-Free)	98 Units / Rail
MC10ELT21DR2G	SOIC-8 (Pb-Free)	2500 / Tape & Reel
MC10ELT21DTG	TSSOP-8 (Pb-Free)	100 Units / Rail
MC10ELT21DTR2G	TSSOP-8 (Pb-Free)	2500 / Tape & Reel
MC100ELT21DG	SOIC-8 (Pb-Free)	98 Units / Rail
MC100ELT21DR2G	SOIC-8 (Pb-Free)	2500 / Tape & Reel
MC100ELT21DTG	TSSOP-8 (Pb-Free)	100 Units / Rail
MC100ELT21DTR2G	TSSOP-8 (Pb-Free)	2500 / Tape & Reel

†For information on tape and reel specifications, including part orientation and tape sizes, please refer to our Tape and Reel Packaging Specifications Brochure, BRD8011/D.

Resource Reference of Application Notes

- AN1405/D** – ECL Clock Distribution Techniques
- AN1406/D** – Designing with PECL (ECL at +5.0 V)
- AN1503/D** – ECLinPS™ I/O SPiCE Modeling Kit
- AN1504/D** – Metastability and the ECLinPS Family
- AN1568/D** – Interfacing Between LVDS and ECL
- AN1672/D** – The ECL Translator Guide
- AND8001/D** – Odd Number Counters Design
- AND8002/D** – Marking and Date Codes
- AND8020/D** – Termination of ECL Logic Devices
- AND8066/D** – Interfacing with ECLinPS
- AND8090/D** – AC Characteristics of ECL Devices

MC10ELT21, MC100ELT21

PACKAGE DIMENSIONS

SOIC-8 NB
CASE 751-07
ISSUE AK

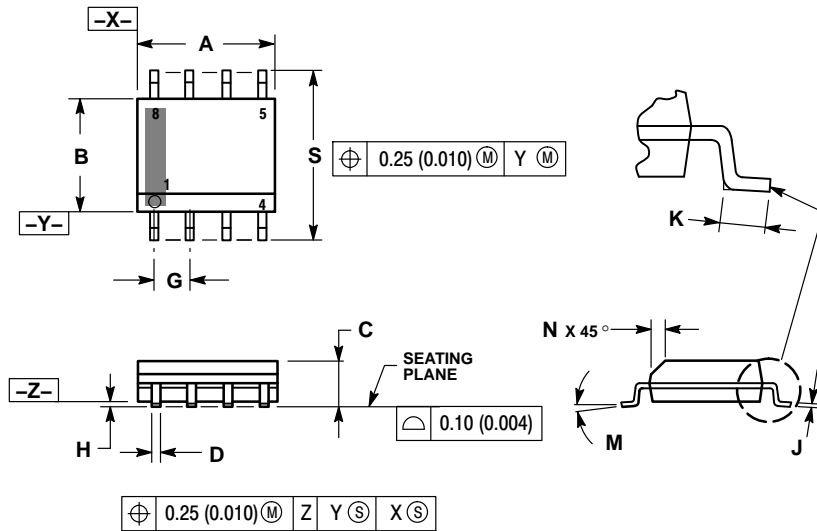

NOTES:

1. DIMENSIONING AND TOLERANCING PER ANSI Y14.5M, 1982.
2. CONTROLLING DIMENSION: MILLIMETER.
3. DIMENSION A AND B DO NOT INCLUDE MOLD PROTRUSION.
4. MAXIMUM MOLD PROTRUSION 0.15 (0.006) PER SIDE.
5. DIMENSION D DOES NOT INCLUDE DAMBAR PROTRUSION. ALLOWABLE DAMBAR PROTRUSION SHALL BE 0.127 (0.005) TOTAL IN EXCESS OF THE D DIMENSION AT MAXIMUM MATERIAL CONDITION.
6. 751-01 THRU 751-06 ARE OBSOLETE. NEW STANDARD IS 751-07.

DIM	MILLIMETERS		INCHES	
	MIN	MAX	MIN	MAX
A	4.80	5.00	0.189	0.197
B	3.80	4.00	0.150	0.157
C	1.35	1.75	0.053	0.069
D	0.33	0.51	0.013	0.020
G	1.27 BSC		0.050 BSC	
H	0.10	0.25	0.004	0.010
J	0.19	0.25	0.007	0.010
K	0.40	1.27	0.016	0.050
M	0°	8°	0°	8°
N	0.25	0.50	0.010	0.020
S	5.80	6.20	0.228	0.244

SOLDERING FOOTPRINT*

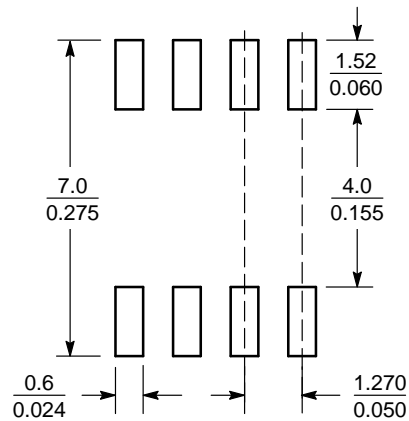

SCALE 6:1 $\left(\frac{\text{mm}}{\text{inches}}\right)$

*For additional information on our Pb-Free strategy and soldering details, please download the ON Semiconductor Soldering and Mounting Techniques Reference Manual, SOLDERRM/D.

MC10ELT21, MC100ELT21

PACKAGE DIMENSIONS

TSSOP-8
DT SUFFIX
CASE 948R-02
ISSUE A

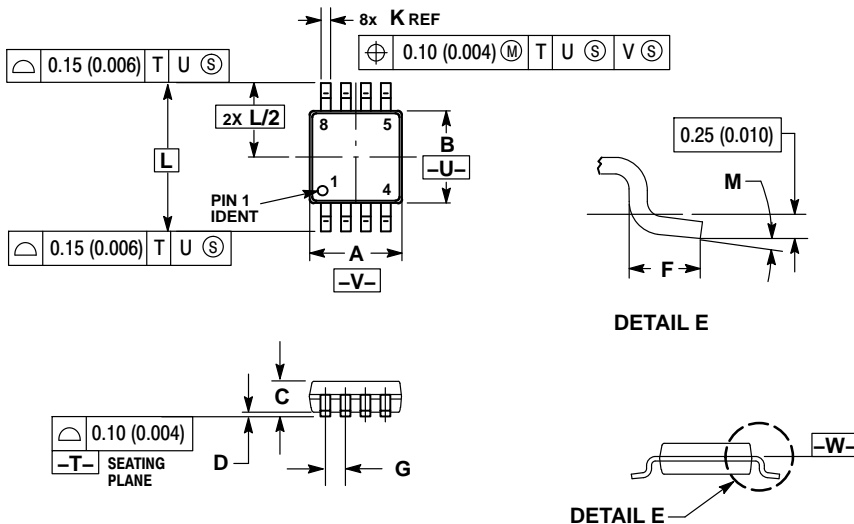

NOTES:

1. DIMENSIONING AND TOLERANCING PER ANSI Y14.5M, 1982.
2. CONTROLLING DIMENSION: MILLIMETER.
3. DIMENSION A DOES NOT INCLUDE MOLD FLASH. PROTRUSIONS OR GATE BURRS. MOLD FLASH OR GATE BURRS SHALL NOT EXCEED 0.15 (0.006) PER SIDE.
4. DIMENSION B DOES NOT INCLUDE INTERLEAD FLASH OR PROTRUSION. INTERLEAD FLASH OR PROTRUSION SHALL NOT EXCEED 0.25 (0.010) PER SIDE.
5. TERMINAL NUMBERS ARE SHOWN FOR REFERENCE ONLY.
6. DIMENSION A AND B ARE TO BE DETERMINED AT DATUM PLANE -V-.

DIM	MILLIMETERS		INCHES	
	MIN	MAX	MIN	MAX
A	2.90	3.10	0.114	0.122
B	2.90	3.10	0.114	0.122
C	0.80	1.10	0.031	0.043
D	0.05	0.15	0.002	0.006
F	0.40	0.70	0.016	0.028
G	0.65 BSC		0.026 BSC	
K	0.25	0.40	0.010	0.016
L	4.90 BSC		0.193 BSC	
M	0°	6°	0°	6°

ECLinPS is a trademark of Semiconductor Components Industries, LLC (SCILLC).

ON Semiconductor and the are registered trademarks of Semiconductor Components Industries, LLC (SCILLC) or its subsidiaries in the United States and/or other countries. SCILLC owns the rights to a number of patents, trademarks, copyrights, trade secrets, and other intellectual property. A listing of SCILLC's product/patent coverage may be accessed at www.onsemi.com/site/pdf/Patent-Marking.pdf. SCILLC reserves the right to make changes without further notice to any products herein. SCILLC makes no warranty, representation or guarantee regarding the suitability of its products for any particular purpose, nor does SCILLC assume any liability arising out of the application or use of any product or circuit, and specifically disclaims any and all liability, including without limitation special, consequential or incidental damages. "Typical" parameters which may be provided in SCILLC data sheets and/or specifications can and do vary in different applications and actual performance may vary over time. All operating parameters, including "Typicals" must be validated for each customer application by customer's technical experts. SCILLC does not convey any license under its patent rights nor the rights of others. SCILLC products are not designed, intended, or authorized for use as components in systems intended for surgical implant into the body, or other applications intended to support or sustain life, or for any other application in which the failure of the SCILLC product could create a situation where personal injury or death may occur. Should Buyer purchase or use SCILLC products for any such unintended or unauthorized application, Buyer shall indemnify and hold SCILLC and its officers, employees, subsidiaries, affiliates, and distributors harmless against all claims, costs, damages, and expenses, and reasonable attorney fees arising out of, directly or indirectly, any claim of personal injury or death associated with such unintended or unauthorized use, even if such claim alleges that SCILLC was negligent regarding the design or manufacture of the part. SCILLC is an Equal Opportunity/Affirmative Action Employer. This literature is subject to all applicable copyright laws and is not for resale in any manner.

PUBLICATION ORDERING INFORMATION

LITERATURE FULFILLMENT:

Literature Distribution Center for ON Semiconductor
19521 E. 32nd Pkwy, Aurora, Colorado 80011 USA
Phone: 303-675-2175 or 800-344-3860 Toll Free USA/Canada
Fax: 303-675-2176 or 800-344-3867 Toll Free USA/Canada
Email: orderlit@onsemi.com

N. American Technical Support: 800-282-9855 Toll Free
USA/Canada
Europe, Middle East and Africa Technical Support:
Phone: 421 33 790 2910
Japan Customer Focus Center
Phone: 81-3-5817-1050

ON Semiconductor Website: www.onsemi.com

Order Literature: <http://www.onsemi.com/orderlit>

For additional information, please contact your local Sales Representative

Looking for pricing, stock, or lifecycle information?

Click below to explore more details on WIN SOURCE:

 [View MC100ELT21DTR2G on WIN SOURCE](#)

 [ON Semiconductor](#) Information

Optimize Your Supply Chain with WIN SOURCE Solutions

-  Global Sourcing Solution
-  Obsolete Management
-  Cost Control Management
-  Shortage Management
-  Alternative Solution
-  Excess Inventory Management